



Instructions for using

SINGER

Sewing Machine 201

T H E S I N G E R C O M P A N Y

Instructions for using
SINGER* 201

ELECTRIC SEWING MACHINE

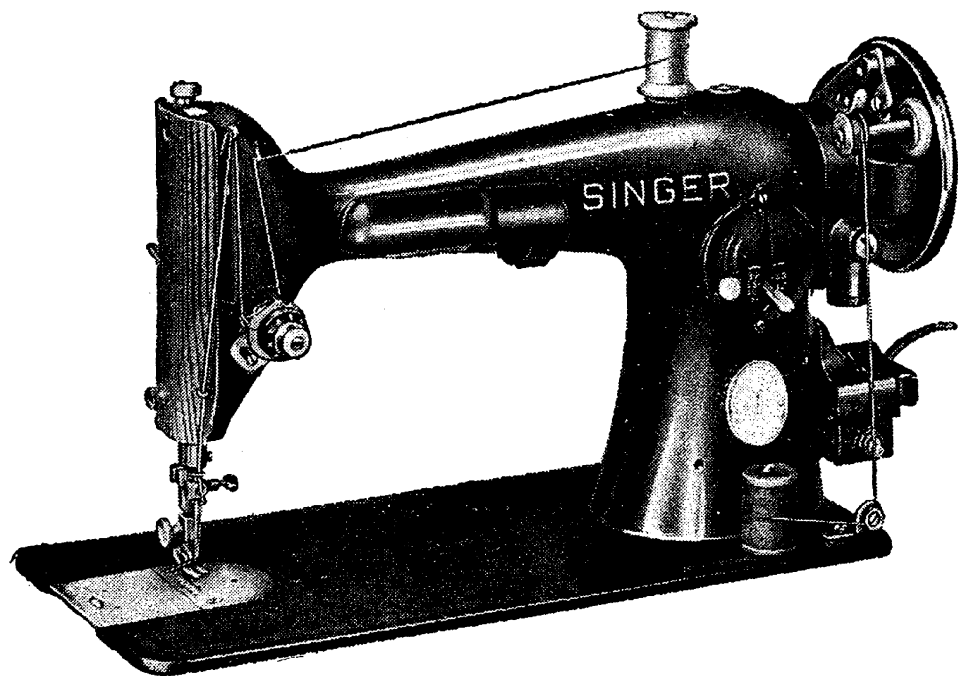

AS THE OWNER OF THIS SINGER 201

You own a machine with a tradition of superior craftsmanship—a tradition you will recognize in the smooth, efficient operation of this motor-driven electric sewing machine. Operating either forward or backward, it forms a lock stitch. The machine and the foot- or knee-operated speed control are stored in any one of a variety of versatile and attractive sewing machine cabinets with extra room for sewing accessories.



Copyright © 1957 by The Singer Company

SINGER SERVICE

Wherever you go you will find expert, dependable SINGER Service nearby. SINGER is interested in helping you keep your SINGER Sewing Machine in top condition. That's why it makes sense to call your SINGER Representative if your machine ever requires attention. He will submit a written estimate for your approval. Look for the familiar red "S" on your SINGER SEWING CENTER and the handy SINGER Service Car.

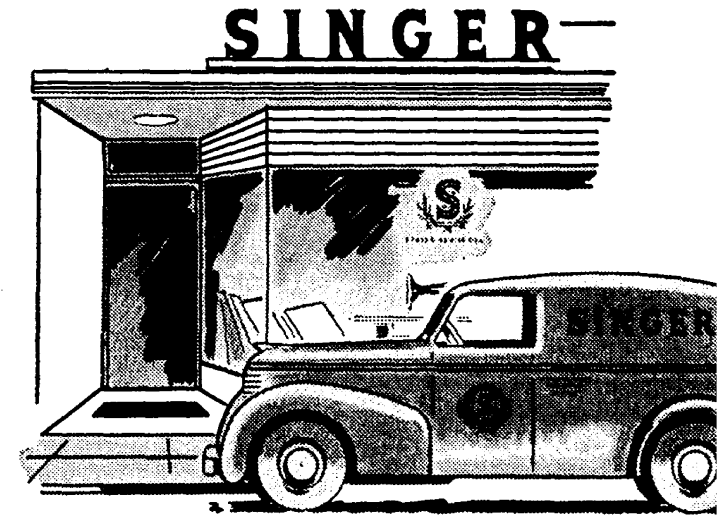

EVERYTHING FOR THE WOMAN WHO SEWS

The answer to your sewing needs is at your SINGER SEWING CENTER. There you will find a wide choice of patterns, buttons and thread, as well as Finishing Services such as covering buttons, hemstitching, making belts and buckles, to mention a few. Look in your telephone directory under The Singer Company for the SINGER SEWING CENTER nearest you.



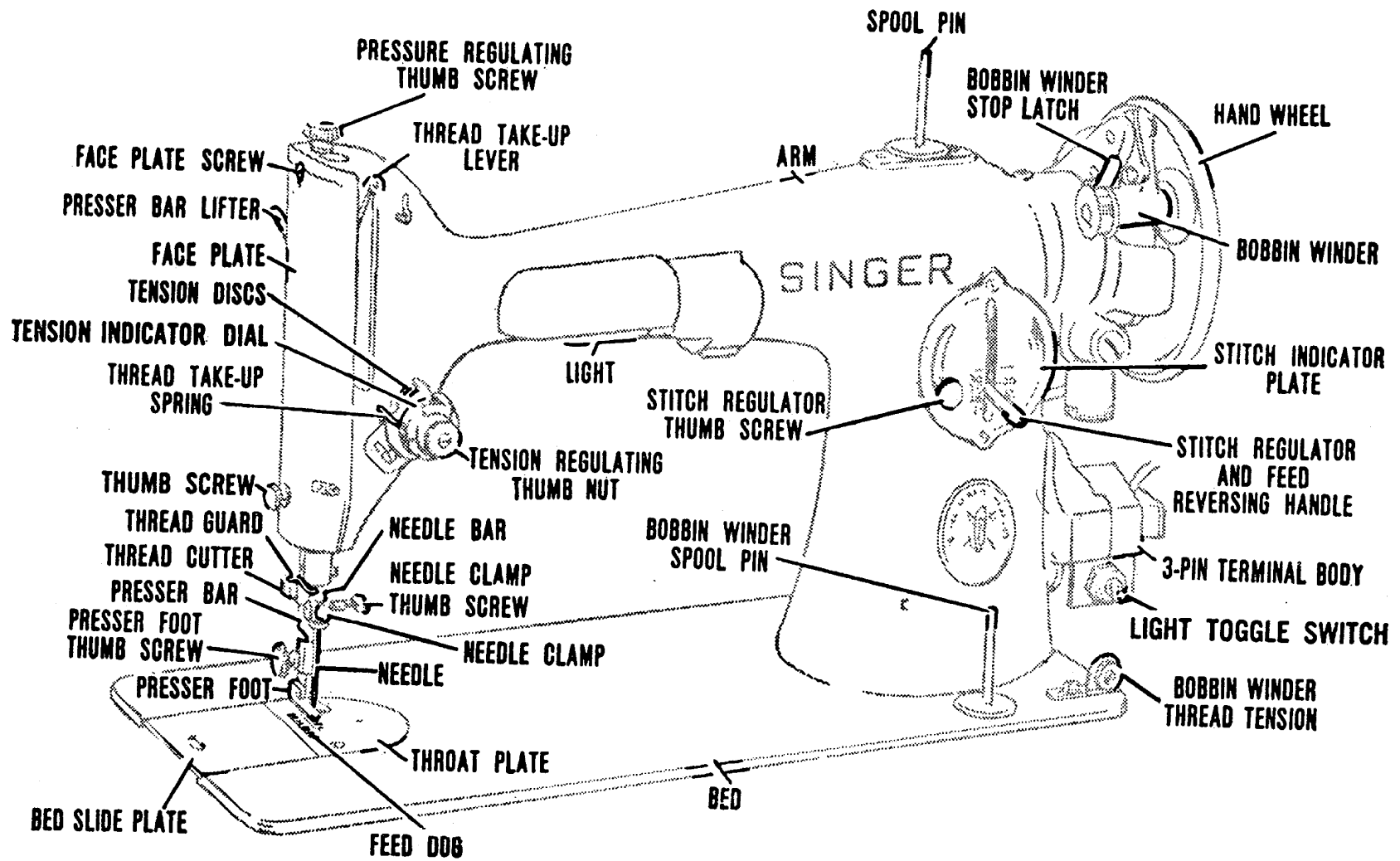

Fig. 2. Names of Principal Parts of Machine

ELECTRICAL INFORMATION

Motor

The SINGER* electric motor, located at back of machine, is regularly furnished for operation on a direct current of 110-120 volts or on alternating current of 110-120 volts, 25 to 75 cycles. Special motors can be furnished for direct or alternating current for any voltage between 50 and 250, and for 32 volts direct current.

To Connect Machine to Electric Service Line

Before connecting the machine to electric service line, be sure that the voltage and the number of cycles stamped on the motor nameplate are within the range marked on the electric meter installed by the electric power company.

Push terminal plug into the three-pin terminal block (see Fig. 2, page 4) at the right of machine and connect plug at other end of cord to an electric outlet.

CAUTION

When you have finished your sewing, always disconnect plug from electric outlet.

LIGHT

To Turn Light "on" or "off"

A switch is conveniently located at front of three-pin terminal block as shown at A in Fig. 3.

To Remove the Bulb

Do not attempt to unscrew the bulb. It is of the bayonet and socket type and does not unscrew. Press bulb into light and at same time turn bulb over toward machine as far as it will go to unlock bulb pin B as shown in Fig. 4. Then withdraw bulb.

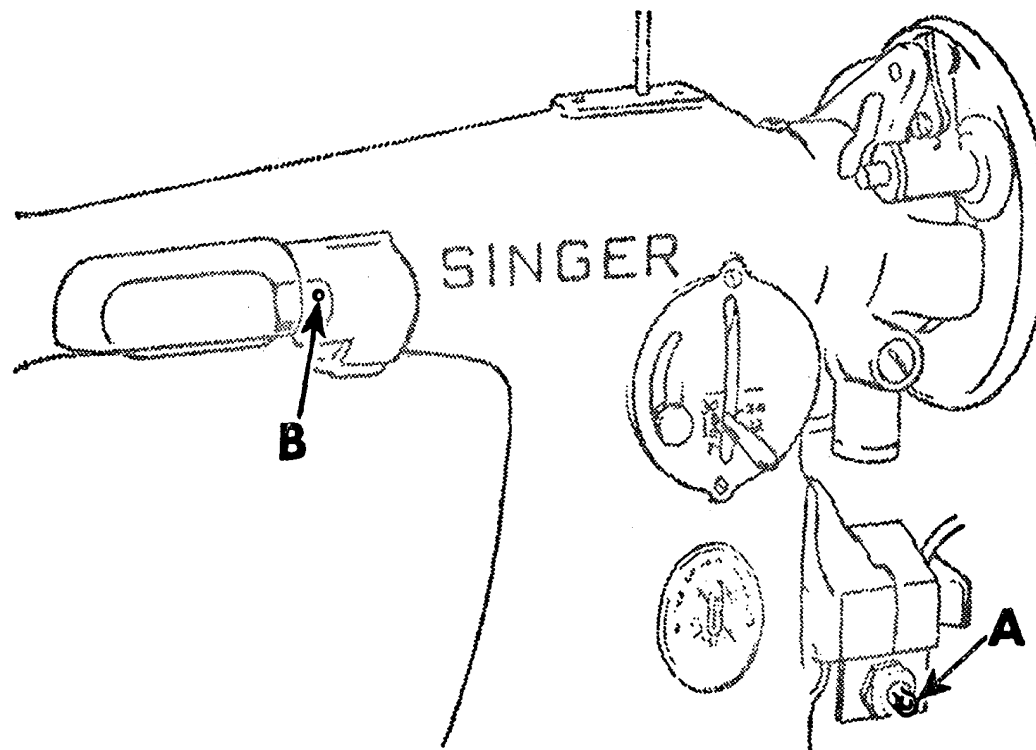

Fig. 3. Electric Light and Switch

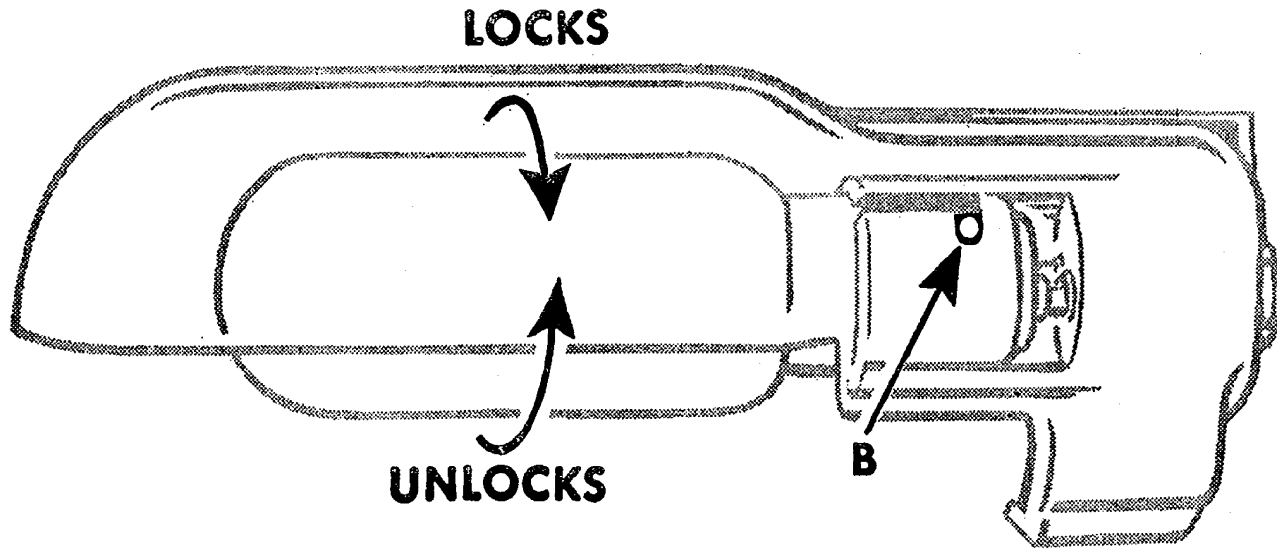

Fig. 4. Locking or Unlocking Bulb Pin

To Insert a New Bulb

Insert a new bulb into light socket, as shown in Fig. 5, and turn it over away from machine, as shown in Fig. 4, until bulb pin **B** enters the notch in socket and locks into position.

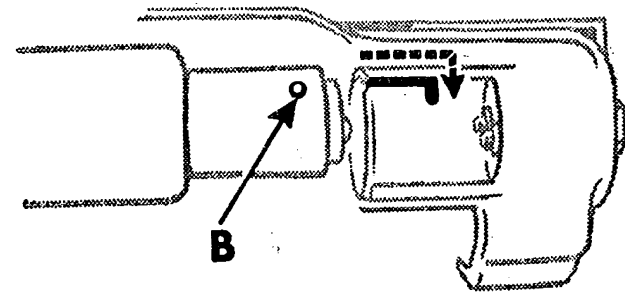

Fig. 5. Inserting Bulb in Socket

NEEDLES AND THREAD

This machine uses a 15X1 Needle —available in sizes 9, 11, 14, 16, 18, 19 and 21.

For perfect stitching, the **thread** should be selected according to the fabric to be stitched and the **needle** must be the correct size for the thread which must pass freely through eye of needle. Select the correct needle according to the chart on **page 9**. Be sure that needle is not blunt or bent.

TO SET THE NEEDLE

Raise needle bar to its highest position and loosen thumb screw **E** in needle clamp. Insert needle, with its **flat side to the left**, up into the needle clamp as far as it will go, then tighten thumb screw **E**.

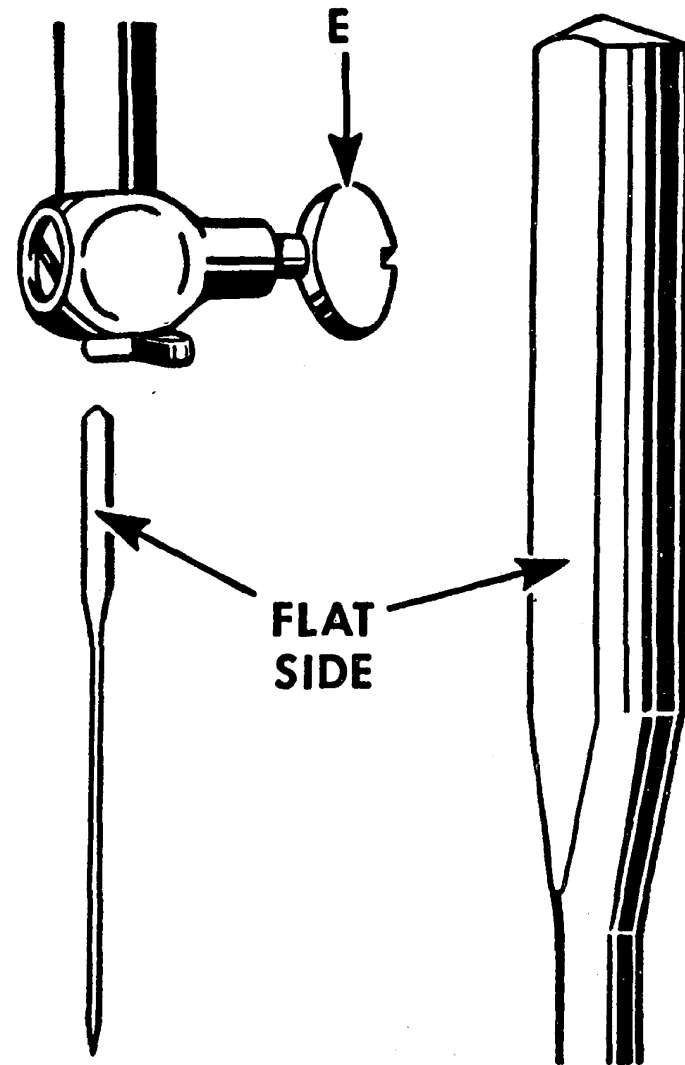

Fig. 6. Setting the Needle

CHART SHOWING THE RELATIONSHIP OF TYPES OF FABRICS, THREAD AND NEEDLE SIZES AND MACHINE STITCH SETTINGS

TYPES OF FABRICS	THREAD SIZES	NEEDLE SIZES	MACHINE STITCH SETTINGS	
			Inside Seams	Top Stitching
Filmy materials comparable to net, marquisette, chiffon, silk, organdy, ninon, silk velvet, nylon sheers.	100 Cotton 00 and 000 Silk	9	20	30
Sheer materials comparable to lawn, dimity, voile, batiste, rayon sheer, rayon crepe, silk crepe.	80 to 100 Cotton 0 Silk	11	16	20
Lightweight materials comparable to gingham, chambray, sheer wool crepe, taffeta.	50 Mercerized 60 to 80 Cotton A or B Silk	14	12	18
Medium lightweight materials comparable to poplin, pique, percale, chintz, faille, bengaline, wool flannel, wool crepe, wool jersey.	50 Mercerized 50 to 70 Cotton B Silk	14	12	16
Medium heavy materials comparable to crash, gabardine, rep, corduroy, velveteen.	50 Mercerized 40 to 50 Cotton C Silk	16	10	12
Heavy materials comparable to sailcloth, sturdy denim, ticking, drill cloth.	Heavy Duty Merc. 30 to 40 Cotton 24 to 30 Cotton D Silk	18 or 19 18 19 18 or 19	8	10
Very heavy materials comparable to overcoating.	40 to 60 Linen 20 to 24 Cotton E Silk	21	6	8
Plastic materials.	Mercerized Cotton	11	10	12

When ordering needles, always specify "Class and Variety 15 x 1" and state the size and quantity required.

You will obtain the best stitching results from your Sewing Machine if it is fitted with a SINGER Needle.*

TO OPERATE THE MACHINE

Raise presser foot **F** by means of presser bar lifter **G** to prevent injury to the foot **F** and feed **H**.

Place a piece of cloth under presser foot and let the foot down upon it.

Turn on electric current and, if the combination knee and foot controller is installed as a knee controller, press controller to the right, or, if controller is placed on the floor to be used as a foot controller, press down on pedal of controller. As the pressure on controller is increased, the speed of machine is increased, the speed being controlled entirely by amount of pressure on controller. Operate machine in this way, **without being threaded**, until you have become accustomed to guiding the material and operating the controller.

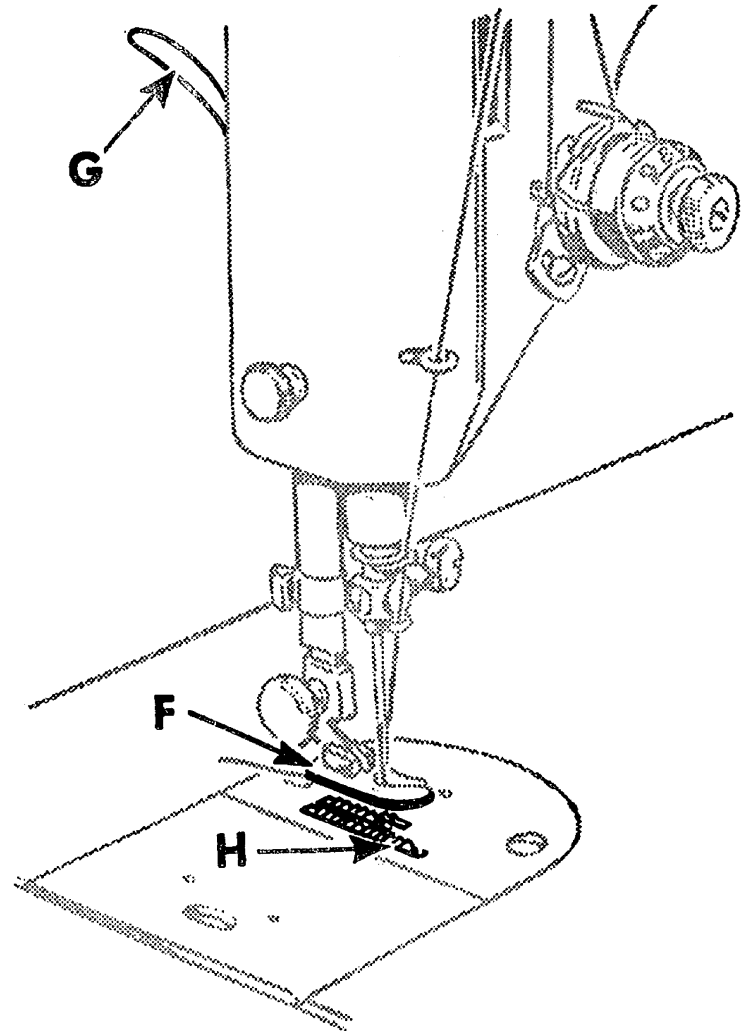

Fig. 7. Front View of Machine

UPPER THREADING

Raise take-up lever 5 to its highest point.
Place spool of thread on spool pin at top of machine

Pass thread through thread guide 1

Down, under and from right to left between tension discs 2 (thread guard J, Fig. 9 guiding thread between discs).

Hold spool tightly and pull thread against take-up spring 4 until it enters retaining fork 3

Pass thread from right to left through hole 5 in take-up lever

Down through guide 6 on face plate

Into guide 7 on needle bar bushing

Into guide 8 on needle clamp

From right to left through eye 9 of needle.

Draw about two inches of thread through eye of needle with which to start sewing.

Fig. 8. Upper Threading

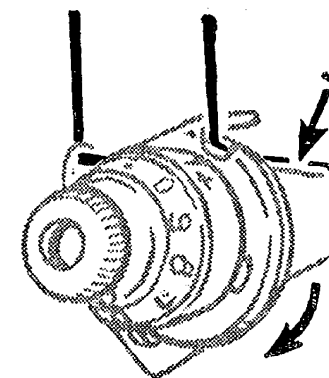
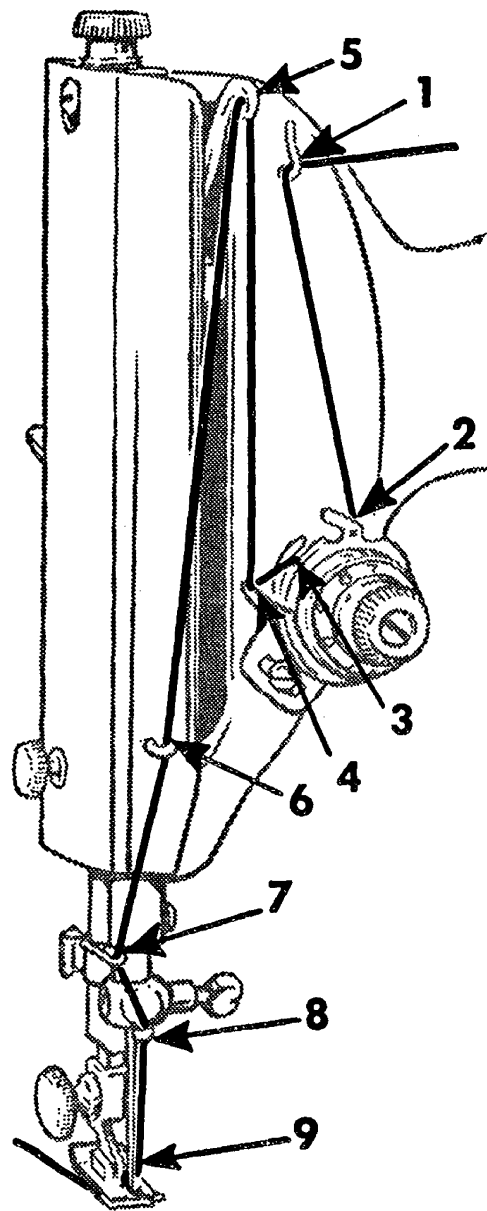

Fig. 9. Threading Tension Discs

TO REMOVE THE BOBBIN

Raise take-up lever 5, Fig. 8 to its highest point. Draw the bed slide toward the left, in the bed of machine. Lift out bobbin with thumb and fore-finger of left hand as shown in Fig. 10.

TO WIND THE BOBBIN

See Fig. 11

1. Place bobbin on spindle with pin of spindle entering slot in right side of bobbin.
2. Lock bobbin in place by pressing bobbin winder down until latch N, Fig. 11 engages.
3. Hold hand wheel L and loosen large knurled screw on hand wheel by turning it over toward you.

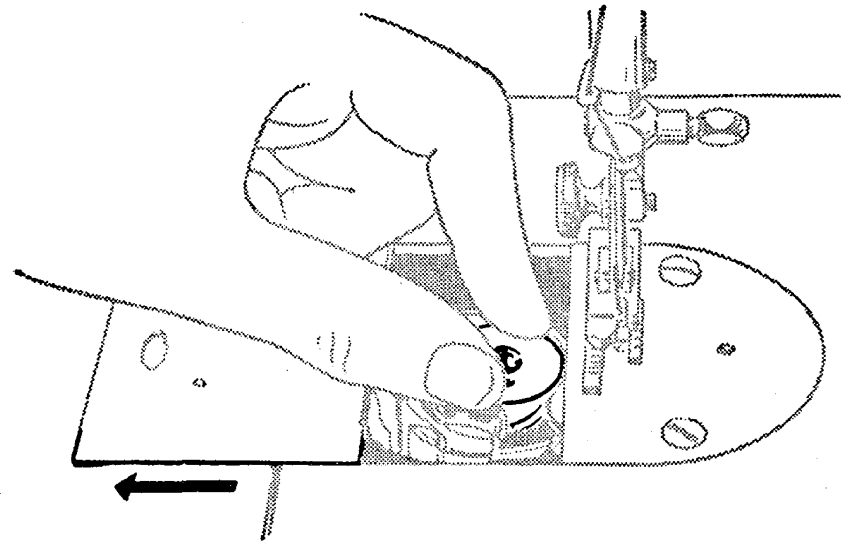

Fig. 10. Removing Bobbin

4. Place spool of thread on spool pin 1. Draw thread under and between tension discs 2. Lead thread up through hole in bobbin 3 from the inside.
5. Hold end of thread as shown in Fig. 11 and press controller as for sewing. Continue to hold end of thread until it breaks off.

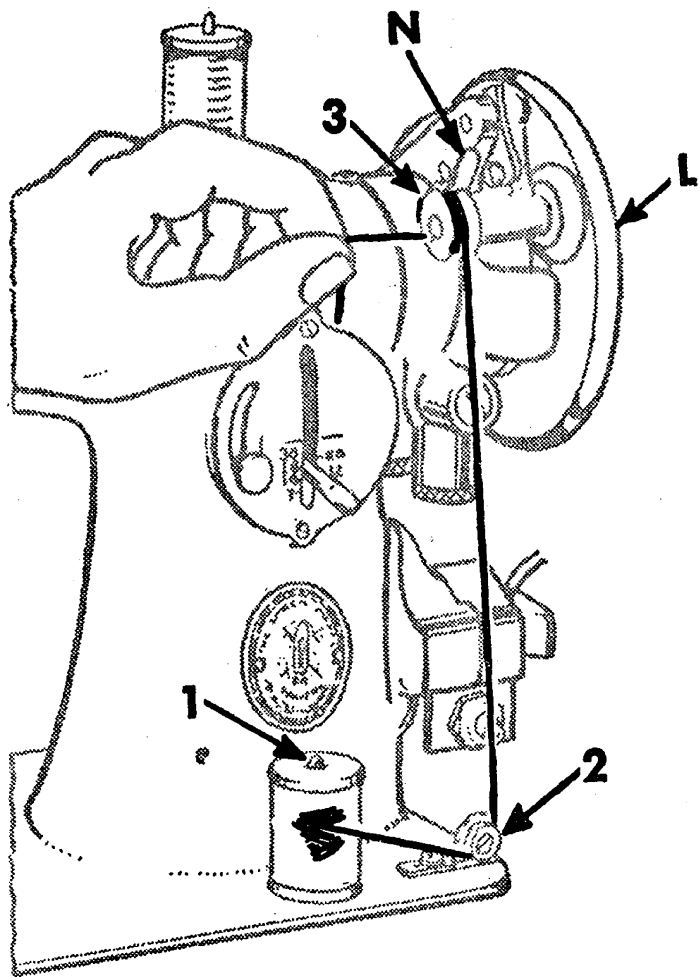

Fig. 11. Winding the Bobbin

Allow tension discs to control flow of thread. Do not guide or hold thread when winding bobbin.

The bobbin winder will stop automatically when the bobbin is filled.

Remove bobbin from spindle and tighten the large knurled screw on the hand wheel **L**.

If pressure of bobbin winder pulley against hub of hand wheel is insufficient for winding the bobbin, press down bobbin winder until latch **N**, **Figs. 11** and **12** drops and holds it in position.

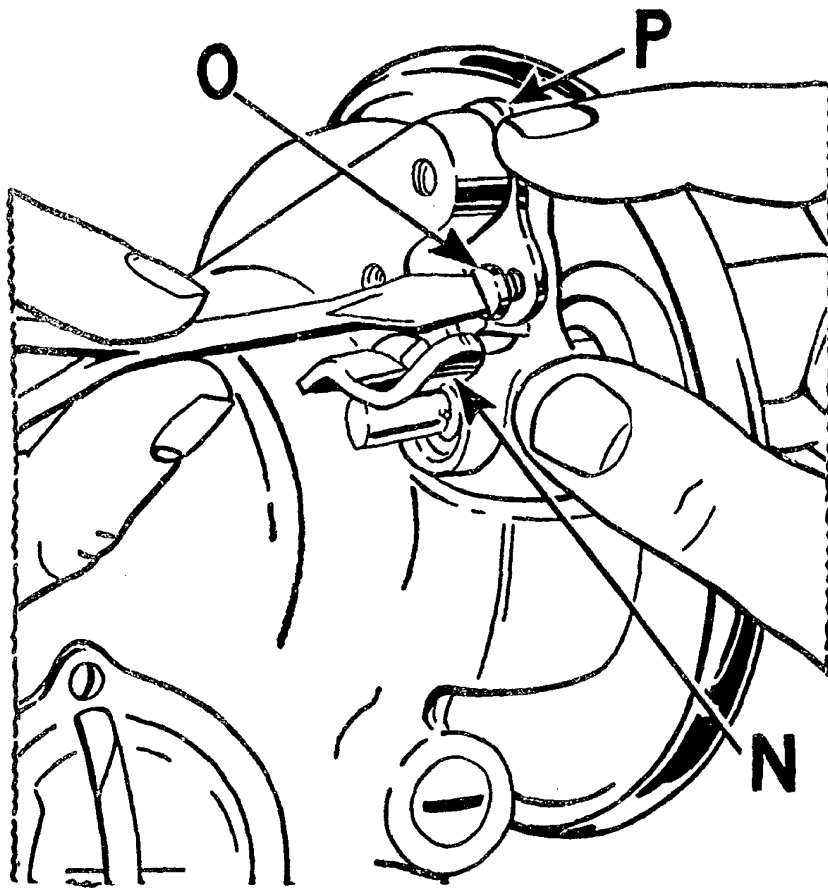

Fig. 12. Adjustment of Bobbin Winder

Loosen adjusting screw **O**, Fig. 12. With forefinger, push back upper end of slotted plate **P** as far as it will go, as shown in Fig. 12, and at the same time, press bobbin winder pulley against hub of hand wheel. Tighten adjusting

screw **O**. If thread does not wind evenly on bobbin, loosen screw which holds tension bracket **2**, Fig. 11 in position.

Move bracket to the left if bobbin winds high on right; move bracket to the right if bobbin winds high on left. When bracket is properly centered, thread will wind evenly across bobbin.

Bobbins can be wound while machine is sewing, by following instructions on page 12, omitting item 3.

TO REPLACE THE BOBBIN AND THREAD THE BOBBIN CASE

Hold bobbin between thumb and forefinger of left hand; thread drawing from right to left, as shown in Fig. 13. Place bobbin in bobbin case. Draw thread into slot **1**, Fig. 14 in bobbin case, as shown in Fig. 14.

Draw thread toward front between bobbin case and tension spring until it passes notch **2**, Fig. 15 in bobbin case, as shown in Fig. 15. Close slide and at

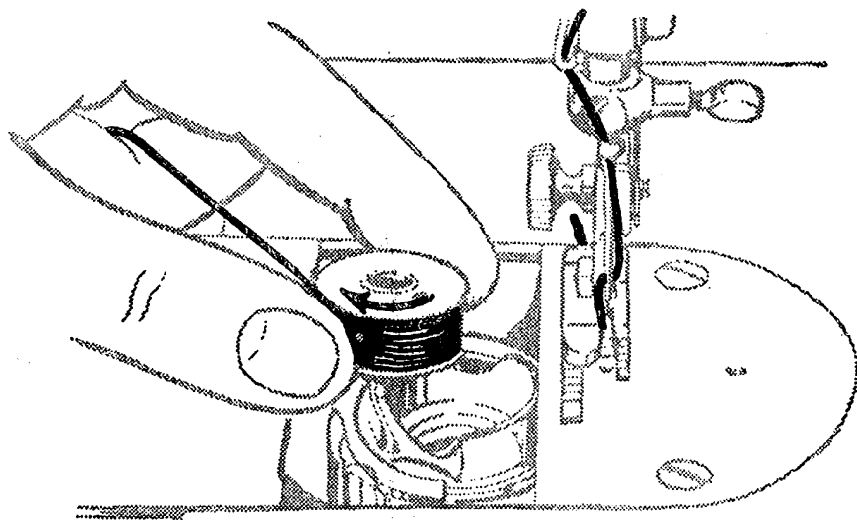

Fig. 13. Replacing Bobbin

same time draw thread into long notch in right edge of slide, as shown at 3, Fig. 16.

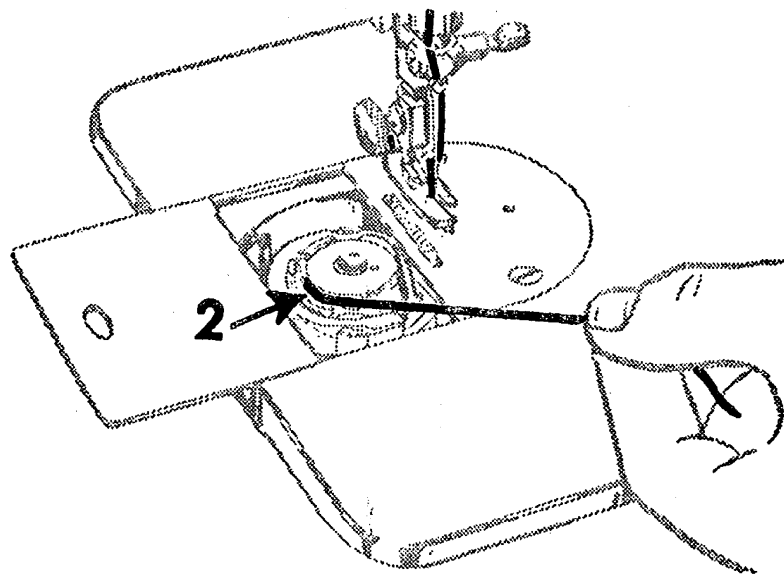

Fig. 15. Bobbin Case Threaded

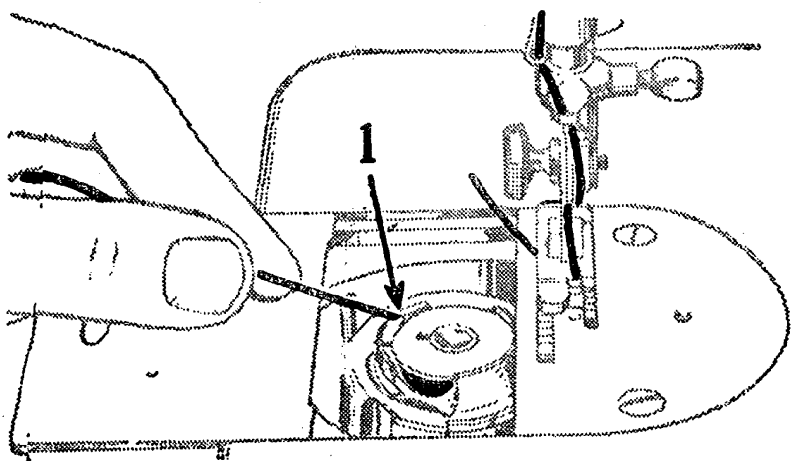

Fig. 14. Threading Bobbin Case

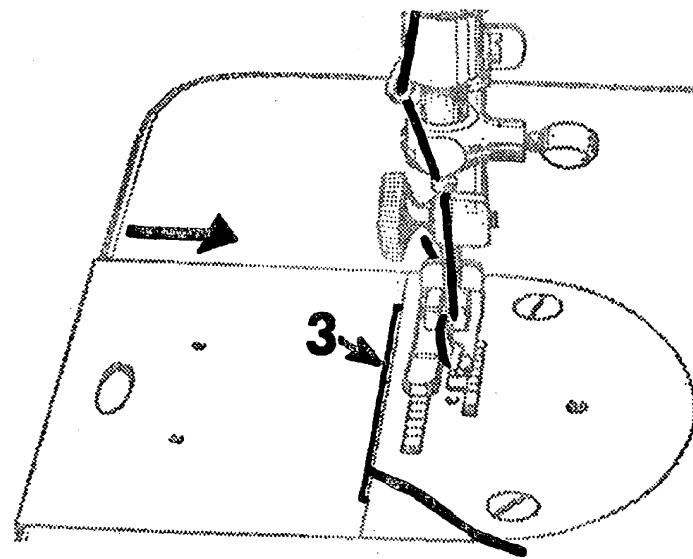

Fig. 16. Under Threading Completed

TO PREPARE FOR SEWING

Hold end of needle thread with left hand and turn hand wheel over toward you

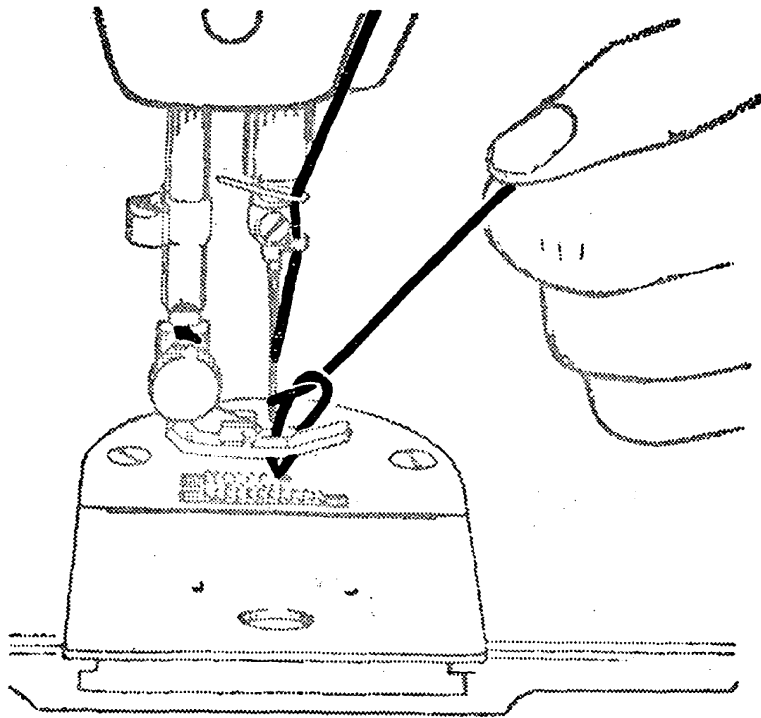

Fig. 17. Drawing Up Bobbin Thread

until needle goes down and up again and thread take-up lever 5, **Fig. 19** is at its highest point. Pull up needle thread and bobbin thread will come with it, as shown in **Fig. 17**.

Lay both threads back under presser foot diagonally across the feed, as shown in **Fig. 18**, to the right or left, depending upon which side of needle the material is to be lo-

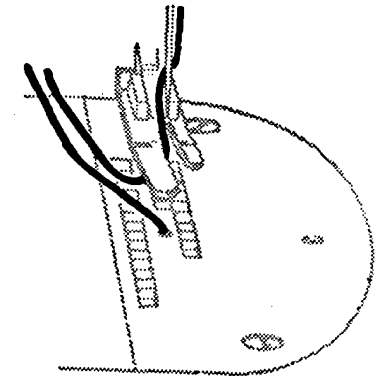

Fig. 18

cated, so that when presser foot is lowered, threads will be firmly held between the feed and the presser foot.

TO START SEWING

1. Bring take-up lever 5 to its highest position.
2. Place material under presser foot F.
3. Position needle in material.
4. Lower presser foot and start to sew.

NOTE:

Most materials require only guiding for best sewing results. However, the miracle fabrics such as nylons, synthetic fabrics, blends with various rayons, puffed weaves, sheers, jerseys and tricots, which, by their nature, require light pressure, also require support in the form of holding the material taut at the back and front of the needle as the needle enters the fabric. This support assures a smooth, even seam. Never pull the material along when stitching.

Never operate the machine without cloth under presser foot.

The slide over the bobbin case should be kept closed when the machine is in operation.

The hand wheel must always turn over toward the operator.

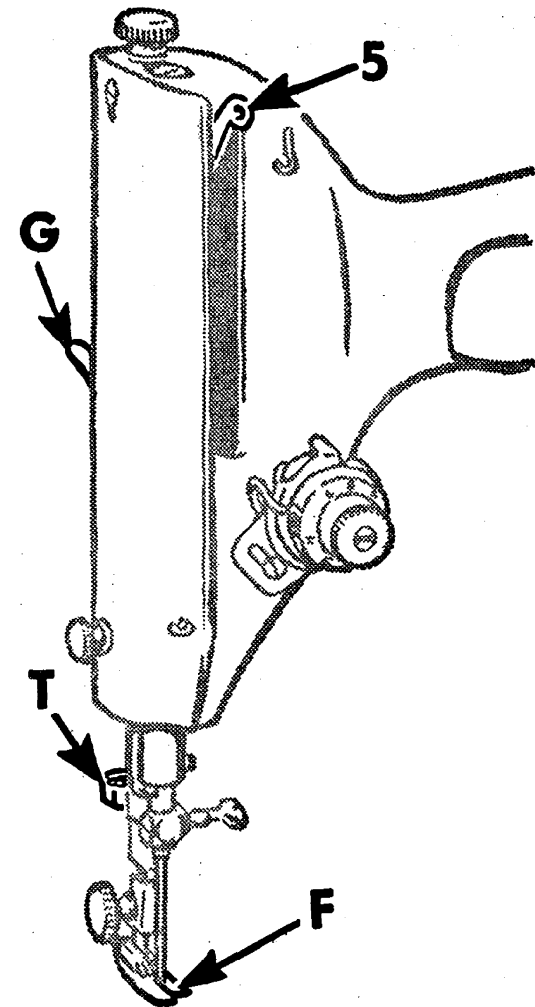

Fig. 19

TO REGULATE LENGTH OF STITCH

The numerals on the stitch indicator plate **V** denote the approximate number of stitches per inch.

To change length of stitch, loosen thumb screw **X** and move it to bottom of slot. Move stitch regulating lever **W** until its upper side is in line with the number of the desired length of stitch.

Move thumb screw **X** until stitch regulating plate (inside) touches lever **W**. Tighten thumb screw **X**.

The machine will then make the indicated number of stitches to the inch in either a forward direction (lever **W** at lowest position) or a reverse direction (lever **W** at highest position).

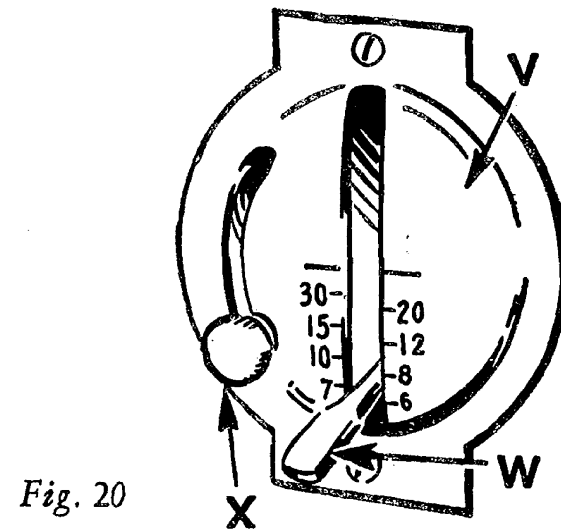

Fig. 20

TO REMOVE THE WORK

Stop machine with thread take-up lever **5**, Fig. 19 at its highest position. Raise presser foot, draw the fabric back and to the left, and sever the threads on thread cutter **T**, Fig. 19. Place ends of threads under presser foot, as shown in Fig. 18.

BASTING

The longest stitch, No. 6 on the stitch regulator, adjusted by lever **W**, **Fig. 20**, is found satisfactory for basting. These basting stitches can be easily removed by clipping every sixth stitch and withdrawing the long, continuous thread.

Machine basting is firmer, more even and much quicker than hand basting.

TO REGULATE DIRECTION OF FEED

To feed the material from you, push down stitch regulator lever **W**, **Fig. 20** to the numeral of stitch desired.

To feed the material toward you, raise stitch regulator to the point where it will make the desired length of stitch.

TO TURN A CORNER

Stop machine when needle is in material. Raise presser foot, turn work as desired, lower the presser foot and resume sewing.

TO SEW BIAS SEAMS

Use a shorter stitch when sewing bias or curved seams to increase the elasticity of the seam and to prevent seam failure under strain. No change in tensions is required.

The direction of feed can be reversed at any point of a seam without removing work from machine.

The reverse feed makes it easy to "back stitch" and to fasten ends of seams.

TO REGULATE PRESSURE ON PRESSER FOOT

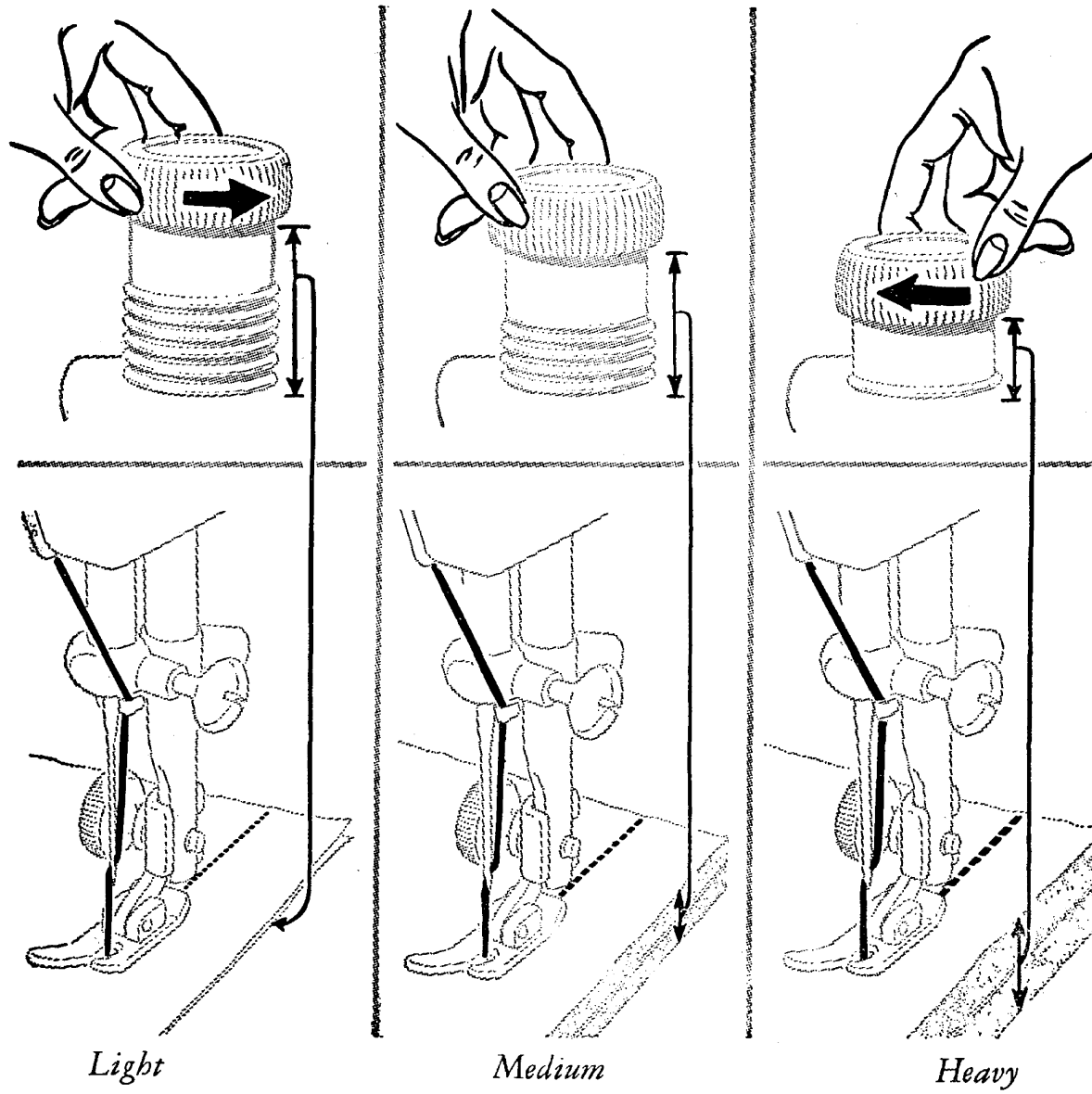
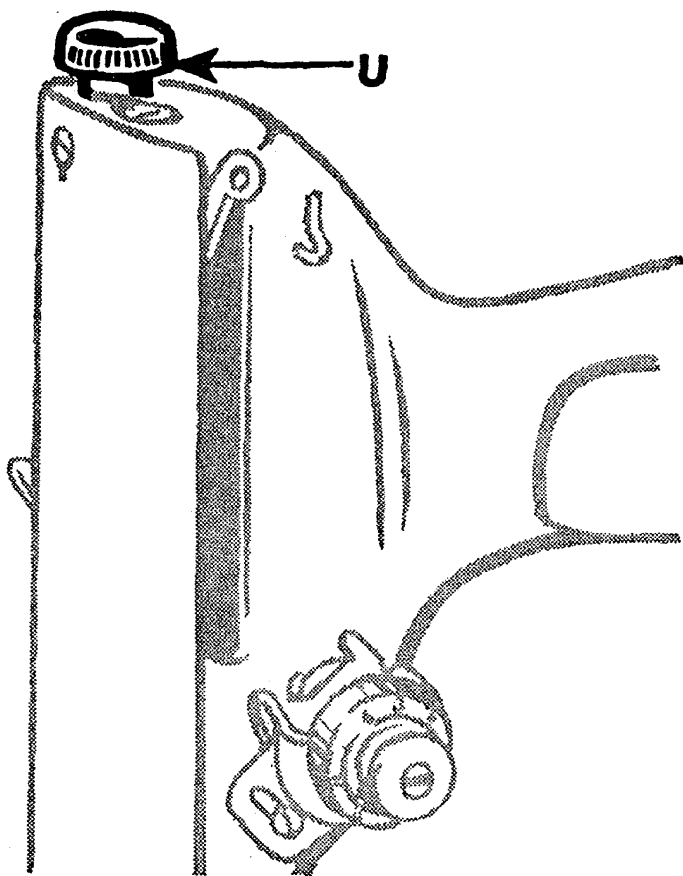

Fig. 21



*Fig. 22. Thumb Screw
for Adjusting Pressure*

The amount of pressure influences the ease with which you achieve a straight seam and uniform stitching. The pressure should be heavy enough to prevent side creepage of material and light enough to carry the material without marking.

To set a light pressure, turn thumb screw **U**, Fig. 22 upward until fabric moves easily under presser foot without slipping and without showing feed marks.

To set a heavy pressure, turn thumb screw **U** downward until the fabric moves easily and the seam edges are carried evenly by the foot and the feed.

THREAD TENSION

For perfect stitching, the tension on needle and bobbin threads must be heavy enough to pull threads to center of material to make a firm stitch.

TO REGULATE THE NEEDLE THREAD TENSION

NOTE: Unless the bobbin thread tension has been altered, a wide range of threads, from fine silk to heavy cottons, can be formed into a perfect stitch by regulating the needle thread tension only.

The tension on needle thread can be tested only when presser foot is down.

The numerals "0" to "9" on dial Y indicate different degrees of tension that can be obtained. The higher the number the greater the tension. The numbers do not denote size of thread or ounces of tension.

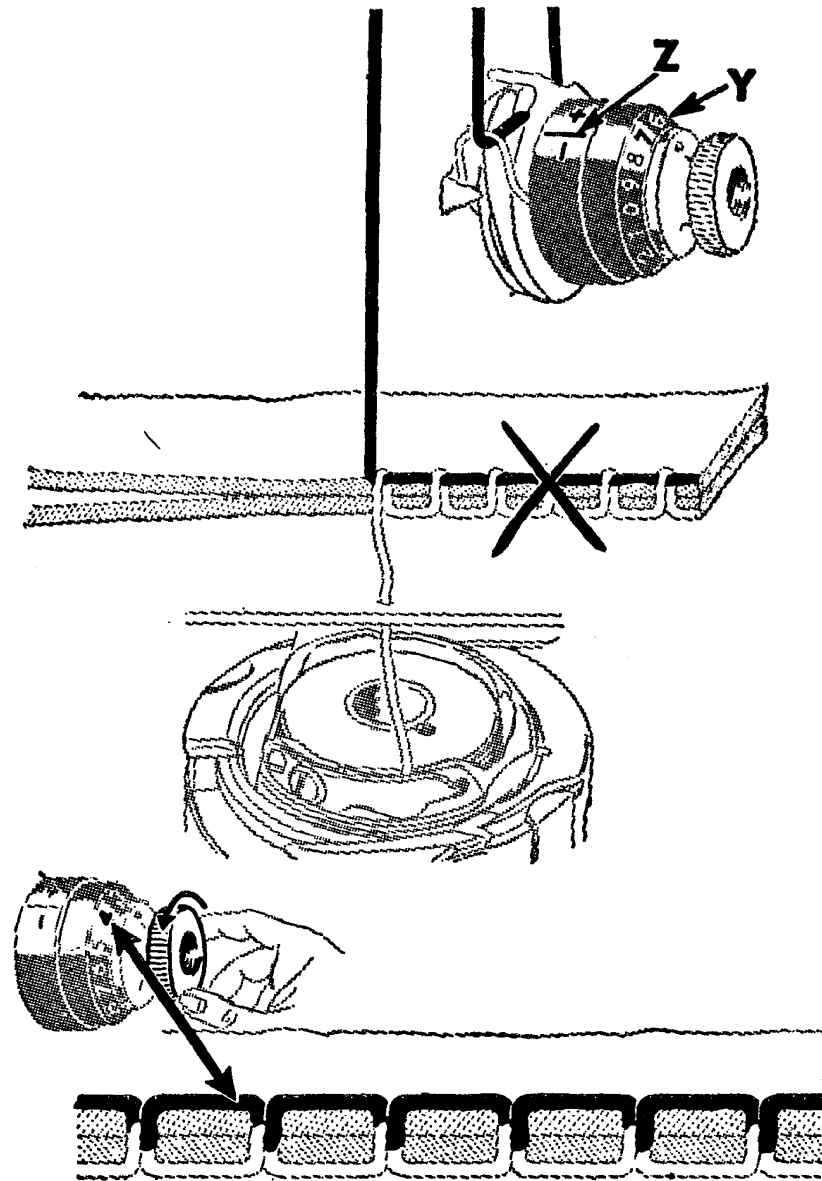

Fig. 23

When tension has been correctly set for average sewing, note number at indicator line **Z**. This setting may be quickly regained should the tension be altered for special work or a change in size of thread.

In the unbalanced tensions shown at top of **Fig. 23** caused by too heavy tension on needle thread, the needle thread lies straight along top side of material.



In the unbalanced tensions shown at top of **Fig. 24**, caused by too light tension on needle thread, the bobbin thread lies straight along under side of material.

If perfect stitching cannot be obtained by regulating the needle thread tension, check for minimum tension at "0" position and **if** necessary adjust as instructed on **page 27**. Then regulate bobbin thread tension as instructed on **pages 24 and 25**.

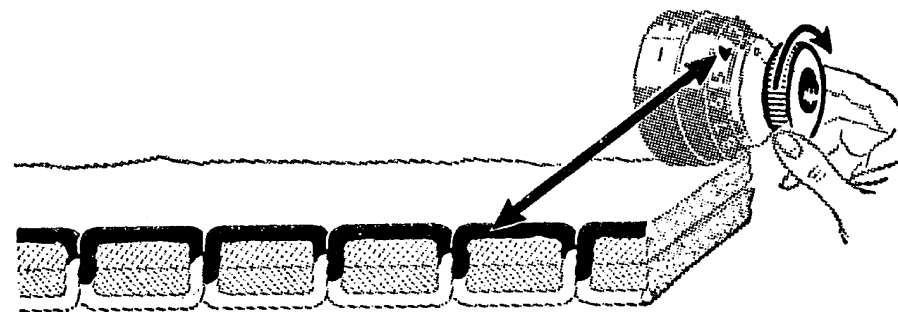
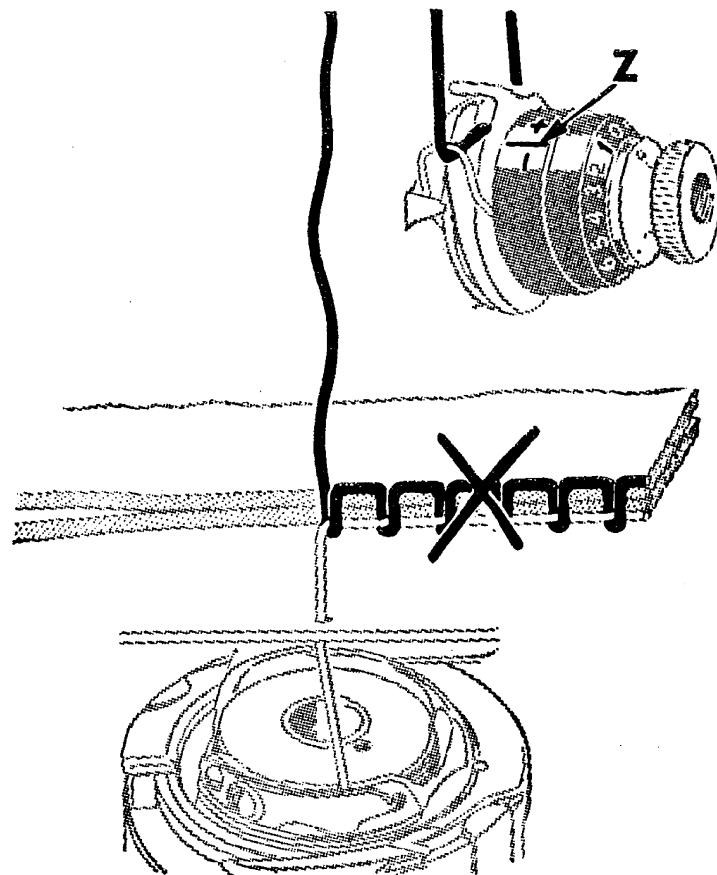

Fig. 24

TO REGULATE THE BOBBIN THREAD TENSION

Set needle thread tension at "4", as shown in Figs. 25 and 26.

The tension on bobbin thread is regulated by the screw of the tension spring, as shown in Fig. 25.

*Fig. 25. Adjustment Required When
Bobbin Tension is too Loose*



When adjusting bobbin tension, a slight turn of the screw is all that is needed to make a fine adjustment.

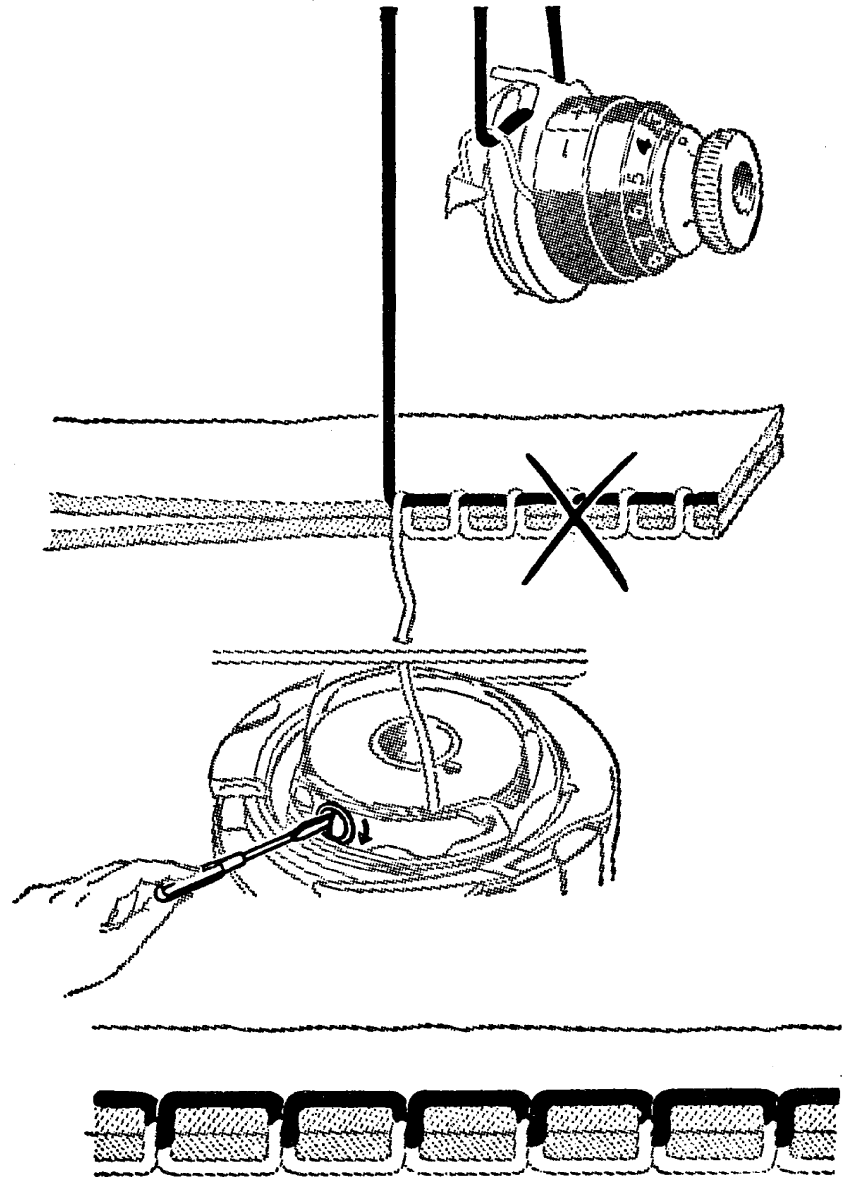

To increase tension, turn screw gradually over to the right.



Fig. 26. Adjustment Required When Bobbin Tension is too Tight



To decrease tension, turn screw gradually over to the left.

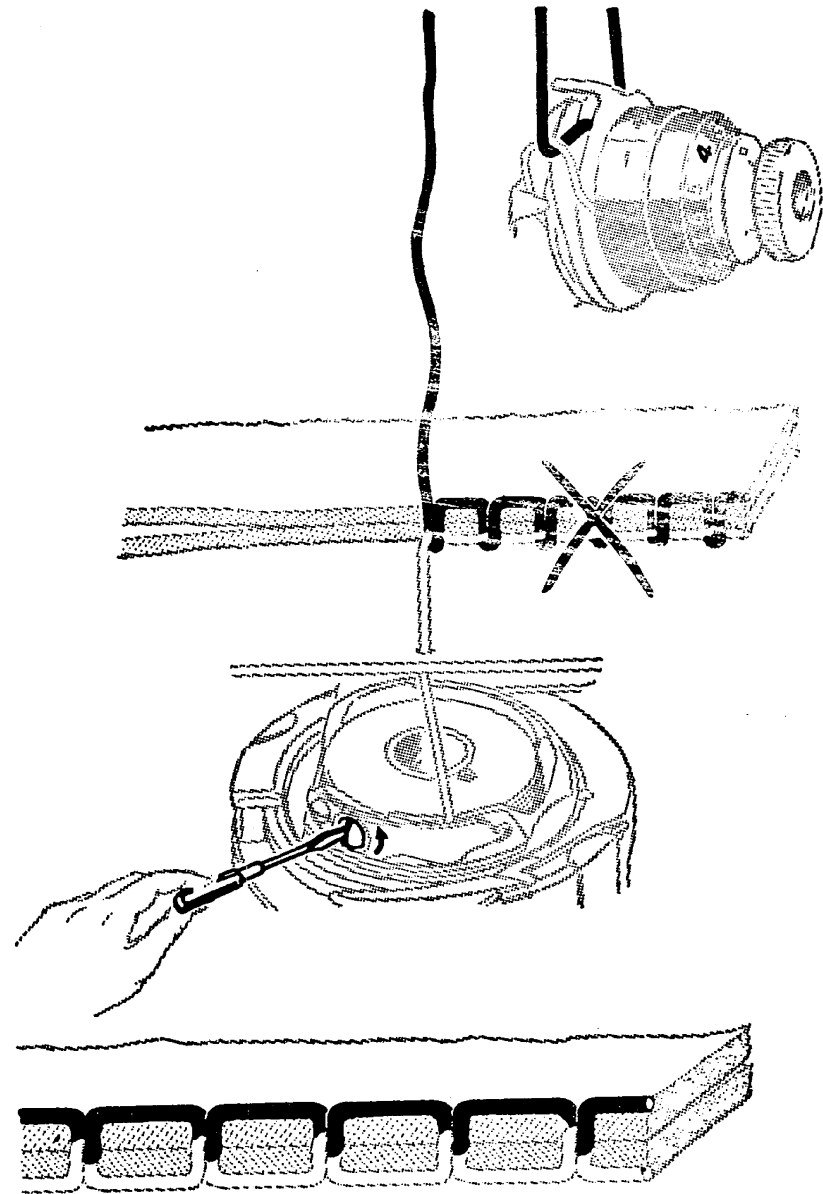

TO REMOVE AND DISASSEMBLE NEEDLE THREAD TENSION

Should it become necessary to remove and disassemble the tension, proceed as follows:

Turn thumb nut **A2**, Fig. 27 over toward the left until it stops at "0" on numbered dial **Y**. Press in dial to disengage pin **B2** in thumb nut and remove

thumb nut. Then remove tension parts from stud **J2** as shown below. To remove pin **H2** from stud **J2**, remove face plate from machine and tilt machine so that the pin will drop out. **Do not remove stud J2.** (It is shown removed in Fig. 27, only for the purpose of illustration.)

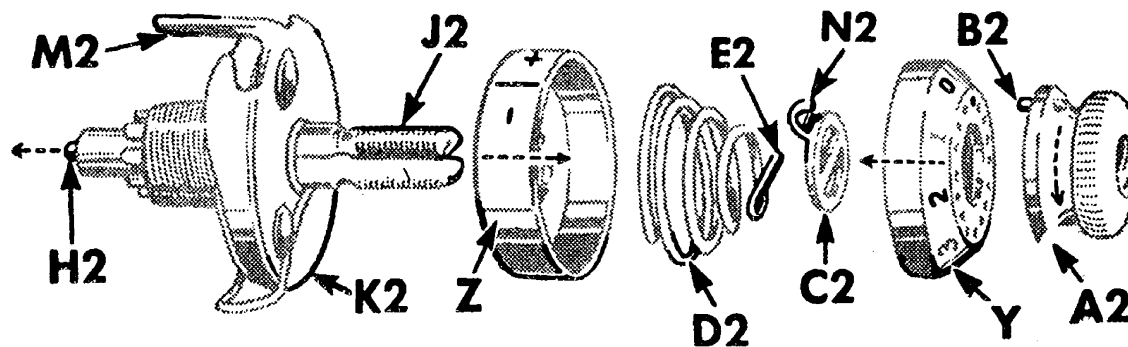

Fig. 27. Needle Thread Tension Disassembled

TO REASSEMBLE AND REPLACE NEEDLE THREAD TENSION

See Fig. 27

Replace face plate, insert tension releasing pin **H2** in stud. Place the two

tension discs on stud, having the flat, thread-bearing sides of discs together. Place thread guard plate **K2** on stud,

being sure that extension **M2** enters the hole provided for it in the arm of the machine to prevent plate from turning on stud.

Next, replace indicator **Z** with the large open side facing end of stud (outward) so that the plus and minus signs can be readily seen from a sewing position. Insert tension spring **D2** in indicator so that first half turn **E2** of this spring will straddle lower half of tension stud. Guide stop washer **C2** onto stud so that extension **N2** will be above tension stud as shown in **Fig. 27**.

Next place numbered dial on stud so that numeral 2 is opposite stop washer extension **N2**, then push dial to compress spring so that thumb nut can be turned onto stud, carefully guiding pin in thumb nut into one of holes in numbered dial. Lower presser bar and turn thumb nut **A2** to left until it stops at

“0”. Thread the tension with size 50 mercerized cotton and pull thread through tension discs to test amount of tension at “0” position. At this point there should be a barely perceptible pull on thread to indicate that there is a minimum tension, which will gradually increase with the turn of thumb nut to right, providing a full range of tensions from light to heavy within one revolution of thumb nut. If pull is too strong for a minimum tension, press in numbered dial **Y**, to disengage pin **B2** in thumb nut from dial and reset pin in one of holes to left of previous setting.

This resetting of pin will produce less tension at zero. On the other hand, should there be insufficient tension at zero, press in dial **Y** and reset pin **B2** in one of holes to right of previous setting. Repeat this process until the desired minimum tension is obtained.

SEWING SUGGESTIONS

Breaking of needles might be caused by:

1. Incorrect size of needle for thread and material. See page 9.
2. Needle bent.
3. Pulling of material when stitching.
4. Needle striking improperly fastened presser foot or attachments.
5. Crossing thick seams with too small a needle.

Breaking of needle thread might be caused by:

1. A knot in the thread.
2. Incorrect threading. See page 11.
3. Upper tension too tight. See pages 22 and 23.

4. Needle set incorrectly. See page 8.
5. Needle blunt or bent.
6. Thread too coarse for needle. See page 9.
7. Roughened hole in throat plate.
8. Incorrect arrangement of threads to start sewing. See page 16.
9. Damaged sewing hook.

Breaking of bobbin thread might be caused by:

1. Incorrect threading of the bobbin case. See page 15.
2. Bobbin thread tension too tight. See pages 24 and 25.
3. Bobbin wound unevenly. See page 14.
4. Damaged bobbin.

Skipping of stitches might be caused by:

1. Incorrect setting of needle. See page 8.
2. Needle blunt or bent.
3. Needle too small for thread. See page 9.
4. Needle rubbing presser foot.

Gathering or Puckering of material might be caused by:

1. Failure to use crisp lawn or organdy backing when stitching on sheer materials.
2. Excessive needle and bobbin thread tensions.

NOTE: If machine runs heavily after standing idle for a long period, apply a few drops of kerosene at all oiling points, run the machine for a few minutes, then wipe clean and apply SINGER* Oil as described on pages 33 to 37.

**SINGER Needles should be used
in SINGER Machines.
These Needles and their Containers
are marked with the
Company's Trade Mark " SINGER " 1**

**Needles in Containers marked
"FOR SINGER MACHINES"
are NOT SINGER made Needles. 2**

DARNING AND EMBROIDERING

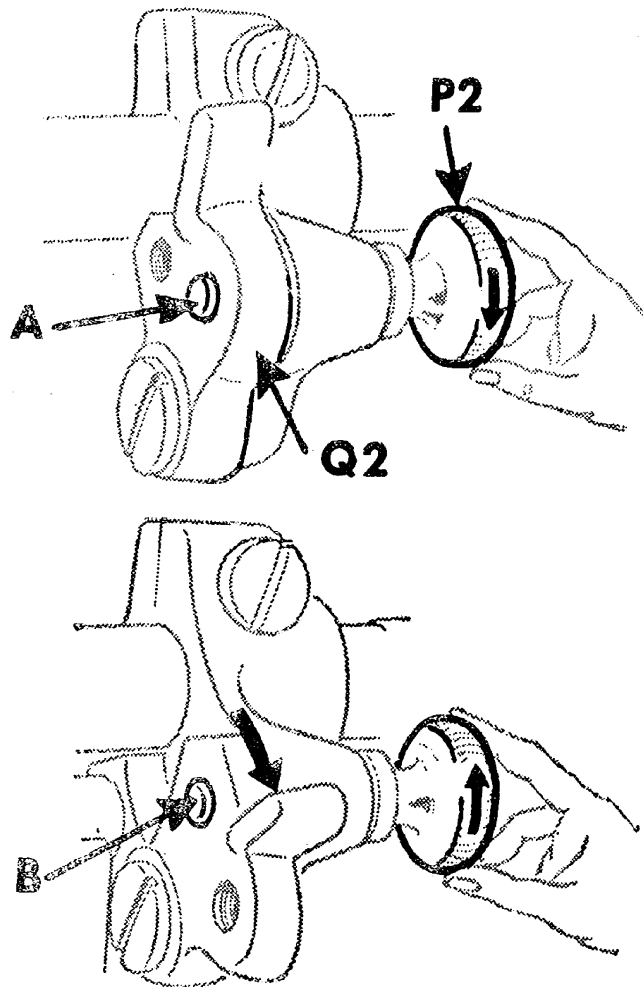

Fig. 28. Preparation for Darning or Embroidery

Turn machine back on its hinges. Unscrew the thumb screw **P2**, **Fig. 28** out of the lower hole **A** in the crank **Q2** until the crank **Q2** is released.

Move feed lifting crank **Q2** downward so that thumb screw **P2** will enter upper hole **B**. Insert thumb screw **P2** in this hole and tighten firmly. The feed is thus rendered inoperative and will not interfere with the free movement of the work. Bring machine forward into place.

Move stitch regulating lever **W**, **Fig. 20**, page 18 to its neutral position in the center of slot at front of machine.

Remove presser foot and let down presser bar lifter **G**, **Fig. 19**, page 17 to restore tension on needle thread which is released when lifter is raised.

Draw up bobbin thread as instructed on page 16.

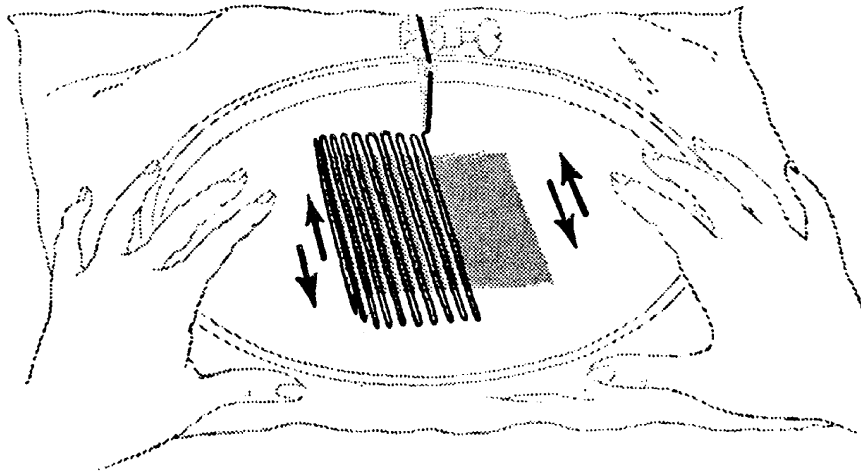

Fig. 29 Starting the Darn

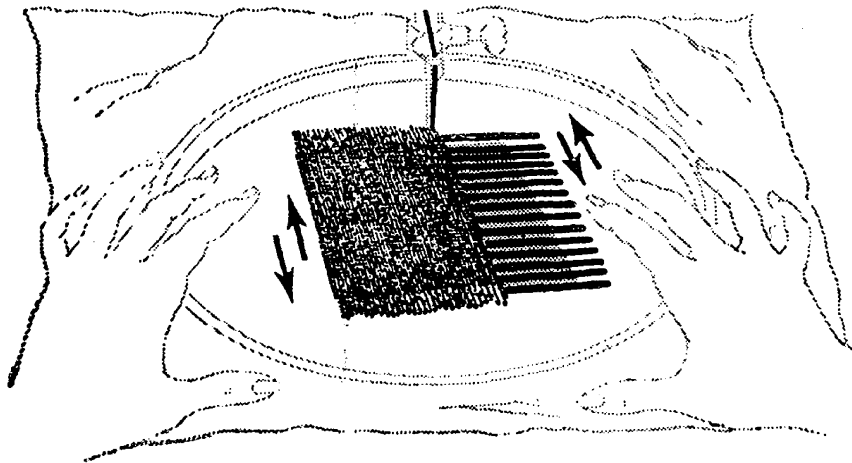

Fig. 30. Darning in Process

Darning:

When darning flat work, it is advisable to use embroidery hoops to hold the work. Place the work in machine, having the unworn part near the hole under the needle. Start darning by making a line of stitches across the hole a little longer than width of hole. Continue making parallel lines of stitches across hole, moving the work backward and forward, as shown in **Fig. 29**, and at same time gradually moving the work sidewise until hole is covered with lines of stitches running across hole. Then turn the work 90°, as shown in **Fig. 30** and continue as before moving the work backward and forward, forming parallel lines of stitches until the first group of stitches across hole are completely covered and the darn is finished.

When you have finished darning, raise presser bar lifter and replace presser

foot. Turn machine back on its hinges and turn thumb screw **P2**, **Fig. 28**, page 30 out of upper hole **B**, **Fig. 28** in feed lifting crank **Q2**, **Fig. 28**, and into lower hole **A**, **Fig. 28**. Make sure that thumb screw is firmly tightened.

Bring machine forward into place, return stitch regulating lever **W**, **Fig. 20**, page 18, to its original position and the machine is ready for regular stitching. Stockings and socks, underwear, etc., can be more conveniently darned on the machine with the SINGER* DARNING and Embroidery Attachment 160720 (page 68).

Embroidering:

Prepare the machine the same as for darning as instructed on page 30, with the following exceptions—

For surface embroidery, remove the presser foot to give a clear view of the stitching in process.

For lace embroidery remove the regular presser foot and replace with Foot 160858 or with Darning and Embroidery Attachment 160720, either of which can be purchased from any SINGER SEWING CENTER or from any SINGER Salesman. See instructions on page 68.

TO OIL THE MACHINE

If machine is used continuously, it should be oiled daily. If moderately used, an occasional oiling is sufficient.

Preparation: Remove face plate. Draw bed slide plate to the left. Remove dust and lint (see instructions on page 38). Swing rear cover plate up toward hand wheel.

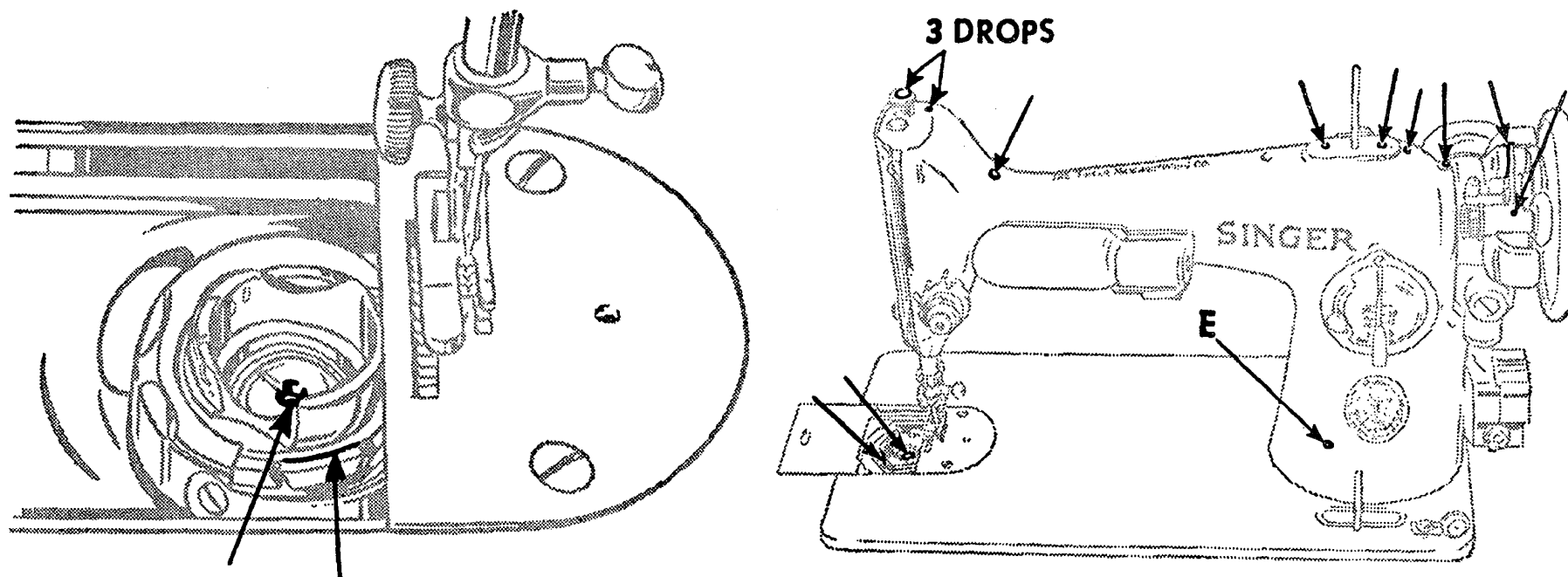
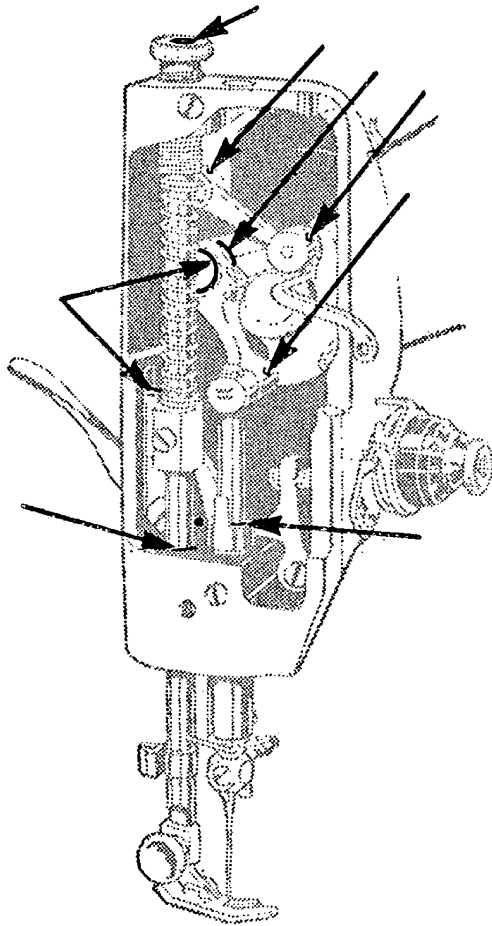

Fig. 31. Front Views Showing Oiling Points



Oiling: Apply a drop of oil to the places indicated by unlettered arrows in Figs. 31, 32, 33 and 34, and 3 drops of oil to the places so indicated in **Figs. 31** and **34**.

After applying one drop of oil to the places indicated by the unlettered arrows in **Fig. 32**, replace face plate and fasten it as before.

Fig. 32. End View Showing Oiling Points

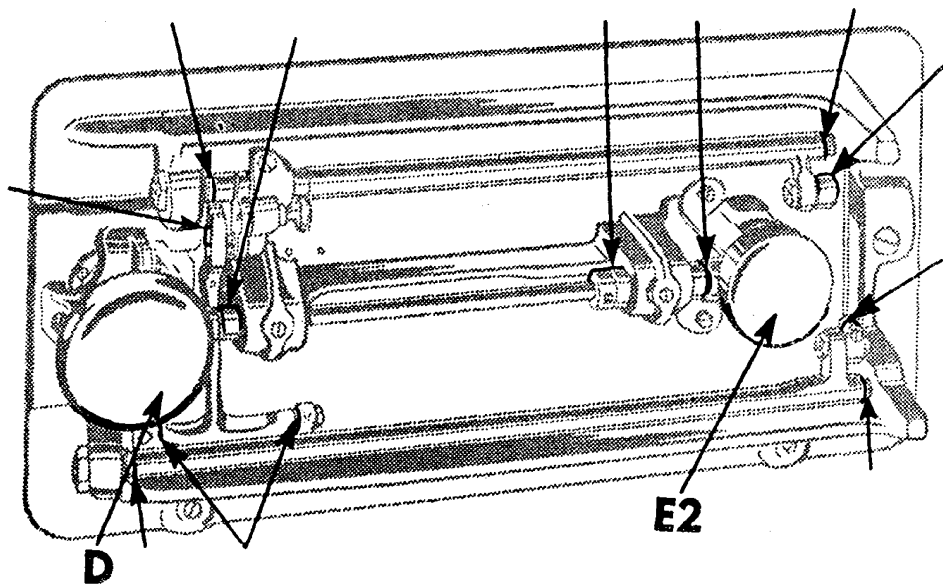

To reach parts underneath bed of machine, turn machine back on its hinges.

Apply one drop of oil to the places indicated by the unlettered arrows in Fig. 33.

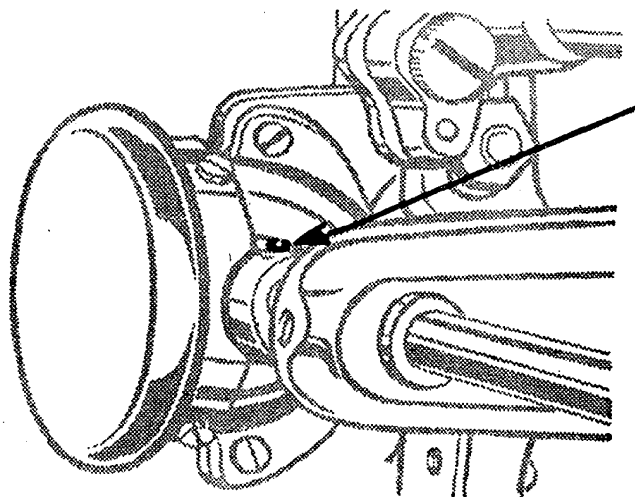

The gears concealed by gear cover **E2**, Fig. 33 are oiled through oil hole **E**, Fig. 31.

The gears concealed by gear cover **D**, Fig. 33 are oiled through the space just above this cover, as indicated by arrow **D2**. After oiling the gears at **D2**, rotate the hand wheel toward you to distribute the oil on these gears.

Fig. 33. Views, Showing Oiling Points in Base of Machine

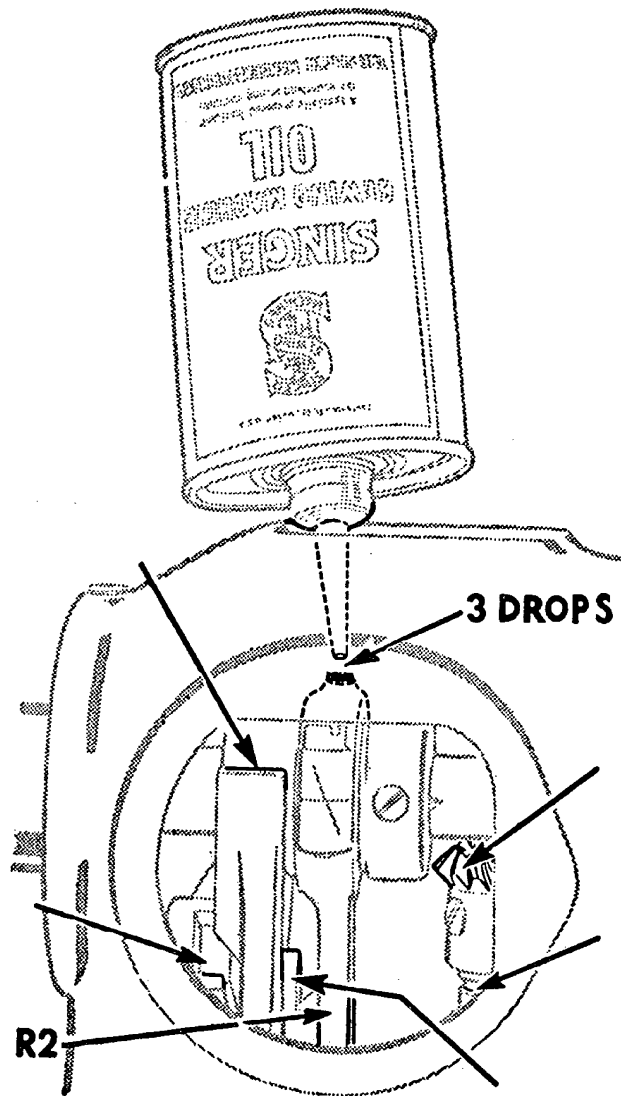

Turn hand wheel over toward you until connecting rod **R2**, Fig. 34 is at its highest position. Then apply oil through hole in top of machine to the wick which is retained in cap of connecting rod, as shown in Fig. 34. Also oil the other moving parts inside and replace cover.

Machine Working Heavily

If the machine runs hard after standing idle for some time, use a little kerosene in the oiling places, run the machine rapidly, then wipe clean and oil.



Fig. 34. Oiling Points At the Back of the Machine

TO LUBRICATE THE MOTOR

NEVER USE OIL OR ORDINARY GREASE FOR LUBRICATING MOTOR. USE the SINGER* Motor Lubricant, supplied with the machine. Machine is shipped from factory with sufficient SINGER Motor Lubricant in motor grease cups T2, Fig. 35, for approximately one year's use.

At least once a year thereafter, turn machine back on its hinges and remove the two thumb screws from the two grease cups T2. Clean out interior of cups. Insert tip of motor lubricant tube into each grease cup as shown in Fig. 35, and while holding tube firmly against bottom of grease cup squeeze enough grease into each cup to fill it. Replace and tighten thumb screws.

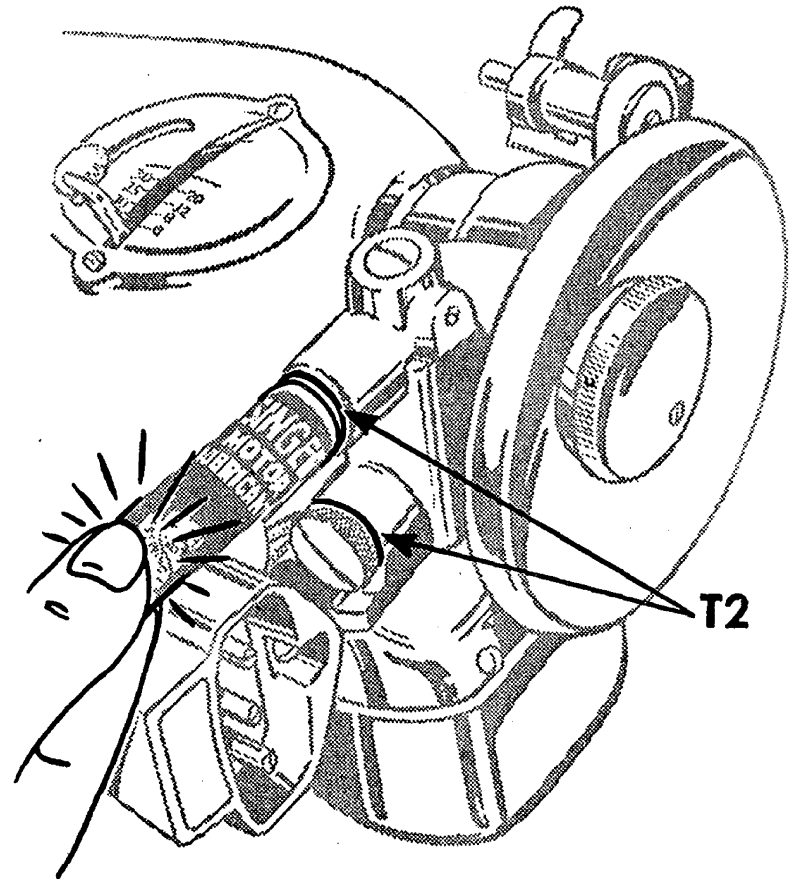

Fig. 35. Lubricating the Motor

TO CLEAN THE STITCH FORMING MECHANISM

After considerable use, the stitch forming mechanism in bed of machine may become clogged with lint and this may interfere with the perfect operation of the machine.

Occasionally remove the bobbin case from machine, as instructed below, and remove any lint, etc., which has accumulated in machine.

TO REMOVE THE BOBBIN CASE

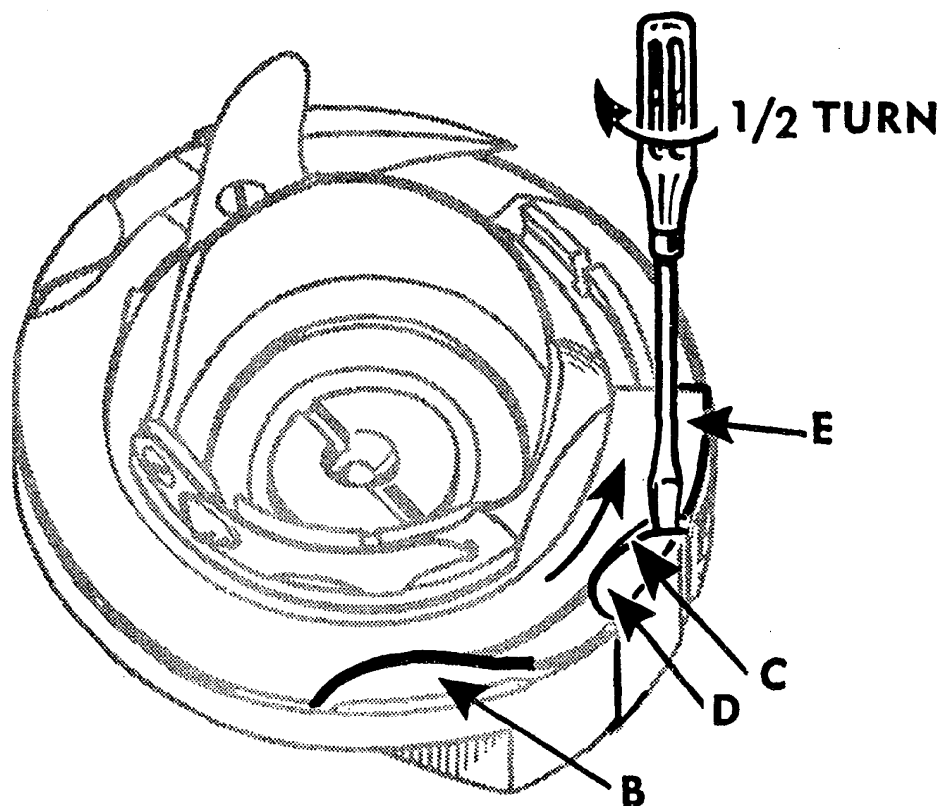

Fig. 36. View from Left End, Showing Position of Bobbin Case and Hook Ring for Removal from Machine

Draw bed slide plate to the left. Turn hand wheel over toward you until needle is at its highest point and end of the hook ring E is toward the front of the machine, as shown in Fig. 36.

Insert the blade of small tension screwdriver 120378, which is furnished with the machine, into slot C between the ring and the edge of the spring, as shown in Fig. 36. With a downward pressure, turn the screwdriver one-half turn to the right so that the screwdriver will drop into the slot and unlock the spring. With the right hand, hold the hand wheel to prevent its turning, and, with the left, place the screwdriver

against the edge of the slot in the ring and push it around in the direction opposite to the hook rotation until the

circular cutout **B** is opposite the spring **D**, as shown in Fig. 37. The ring **E** and bobbin case may then be lifted out.

TO REPLACE THE BOBBIN CASE

When replacing the parts, first place the bobbin case into position with the finger **A**, Fig. 37 in the opening in the position plate under the throat plate as shown in Fig. 37. Turn the bobbin case back and forth slightly to make sure that it is properly seated, then place the hook ring **E** in position with the cutout **B** opposite the spring **D**. Press the ring into place and turn it in the direction of hook rotation until the spring locks it in position. Then replace the bobbin.

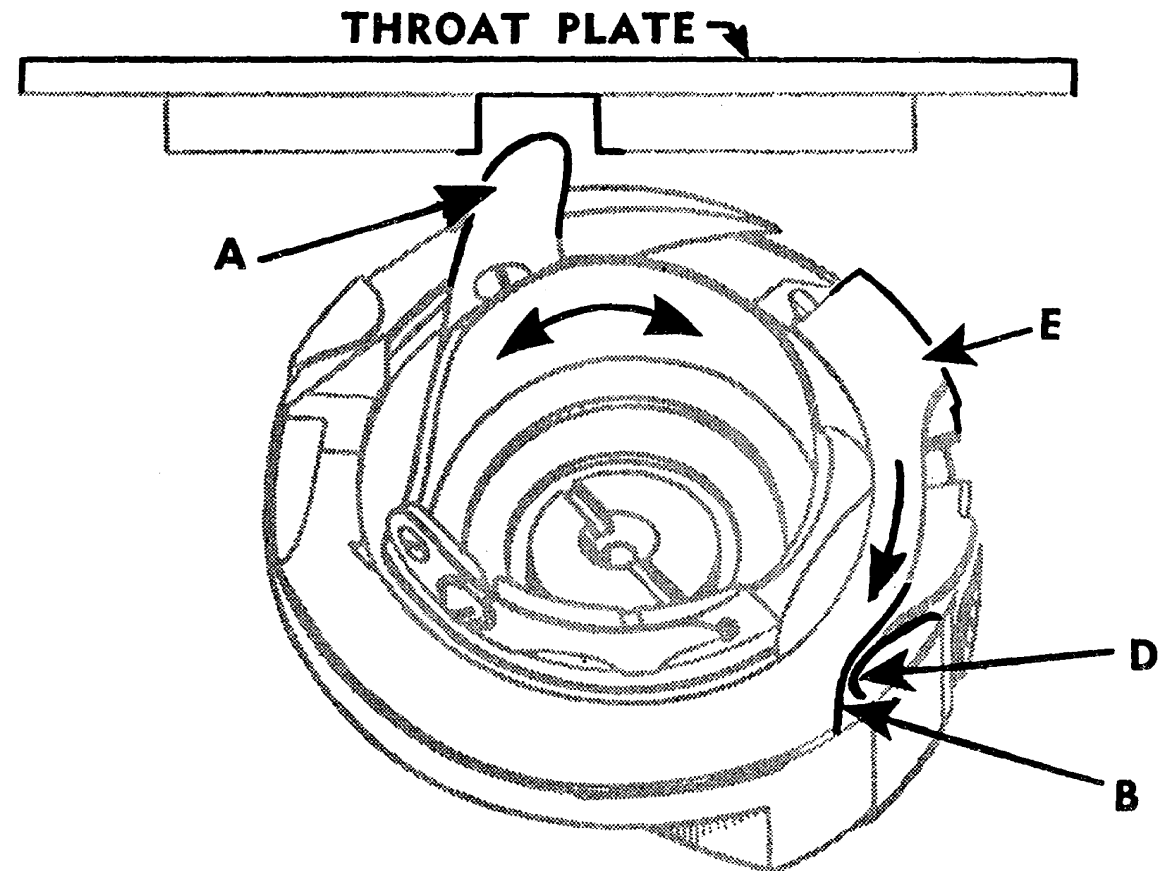

Fig. 37. View from Left End, Showing Replacement of Bobbin Case

Instructions for using

ATTACHMENTS

THE FOOT HEMMER

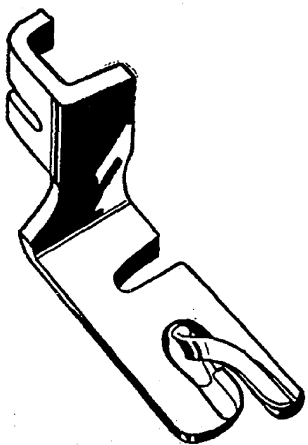

Fig. 38
Foot Hemmer

The foot hemmer may be used for hemming edge of material, making hemmed and felled seams and for hemming and sewing on lace in one operation.

Raise needle to its highest point, remove presser foot and attach foot hemmer to presser bar in place of presser foot.

Pull up bobbin thread as instructed on page 16.

To Start Hem at Very Edge

1. Fold edge of material twice, about $\frac{1}{8}$ inch each time, for a distance of about two inches. Crease folds.

2. Lay about three inches of needle and bobbin threads back under hemmer. Place creased edge of material under hemmer with end of hem directly under needle. Lower hemmer and tack end of hem with two machine stitches.

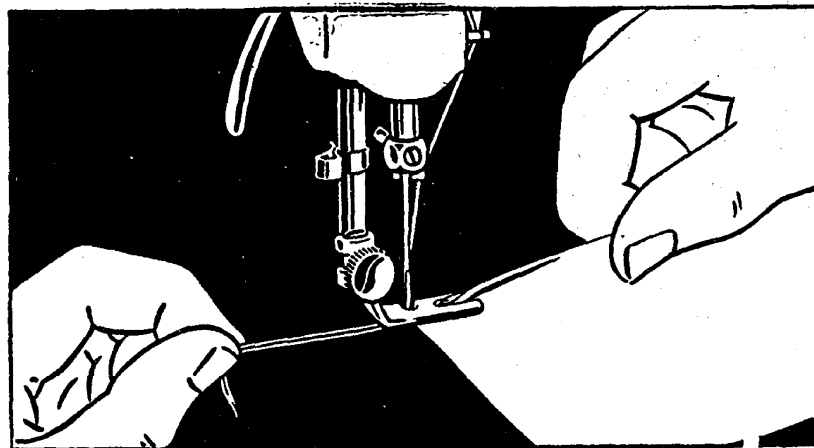

Fig. 39. Starting Hem at Very End of Material

3. Raise hemmer. Pull threads and hem slightly from you with left hand, then while holding threads, draw material toward you, with right hand, into scroll of hemmer until tacked end is caught in hemmer, as shown in Fig. 39.

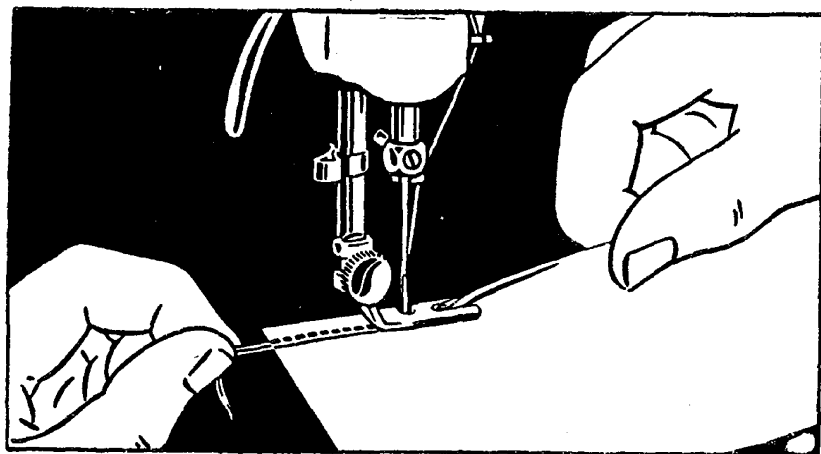

Fig. 40. Hemming Edge of Material and Pulling Back Threads While Sewing

4. Lower hemmer and start to sew, slightly pulling threads back while sewing. Keep mouth of hemmer full to produce a smooth, even hem as shown in Fig. 40.

To Make a Hemmed Seam with Foot Hemmer

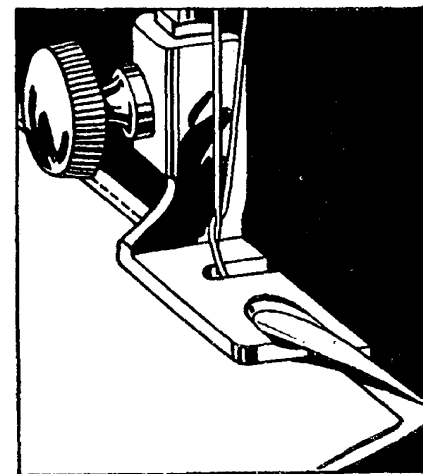

Fig. 41. Making a Hemmed Seam (First Operation)

1. When making this seam, the garment must first be fitted and the edge

of material trimmed, allowing for about $\frac{1}{8}$ inch of seam. Insert the two edges of material, right sides together, in the hemmer in same manner as a single hem as shown in Fig. 41. If the material is bulky, place edge of upper piece of material about $\frac{1}{8}$ inch left of edge of under piece.

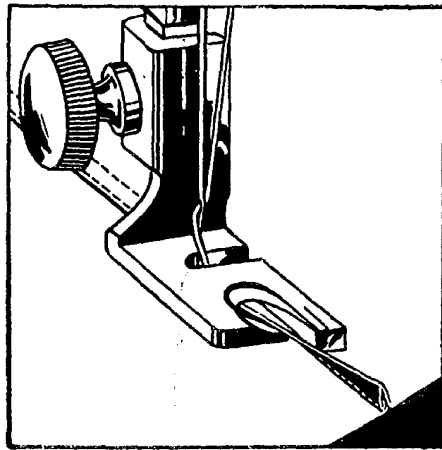

Fig. 42. Making a Hemmed Seam (Second Operation)

2. The free edge of hemmed seam may be stitched flat to garment, if desired. To do this, open the work out flat, wrong side up, then insert the hem in scroll of hemmer, holding edge of hem in position while it is being stitched. If seam is stitched flat to garment, one row of stitching is visible on the right side.

To Make a Felled Seam with Foot Hemmer

1. Place right sides of material together, having edge of upper piece about $\frac{1}{8}$ inch to the left of edge of under piece. Stitch the two pieces together, using hemmer as a presser foot. Guide both pieces by the projecting toe of hemmer, as shown in Fig. 43.

2. Open the work out flat, wrong side up, and hem free edge of seam, stitching it flat to garment as shown in Fig. 44.

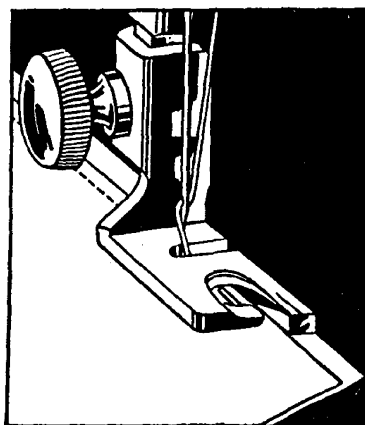

*Fig. 43. Making a
Felled Seam
(First Operation)*

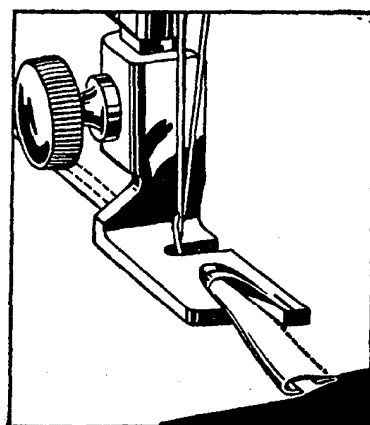

*Fig. 44. Making a
Felled Seam
(Second Operation)*

To Hem and Sew on Lace in One Operation

1. Start hem in regular way.
2. Hold hem in position with needle.

3. Raise presser bar and insert edge of lace in slot of hemmer and back under hemmer.
4. Lower presser bar and start sewing, catching edge of lace with needle.
5. Guide hem with right hand and lace with left hand, being careful not to stretch lace as it enters hemmer.

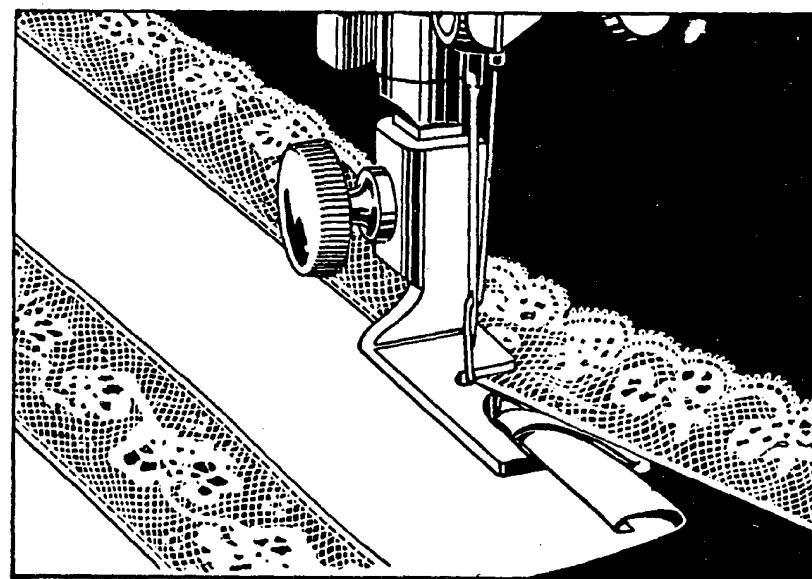
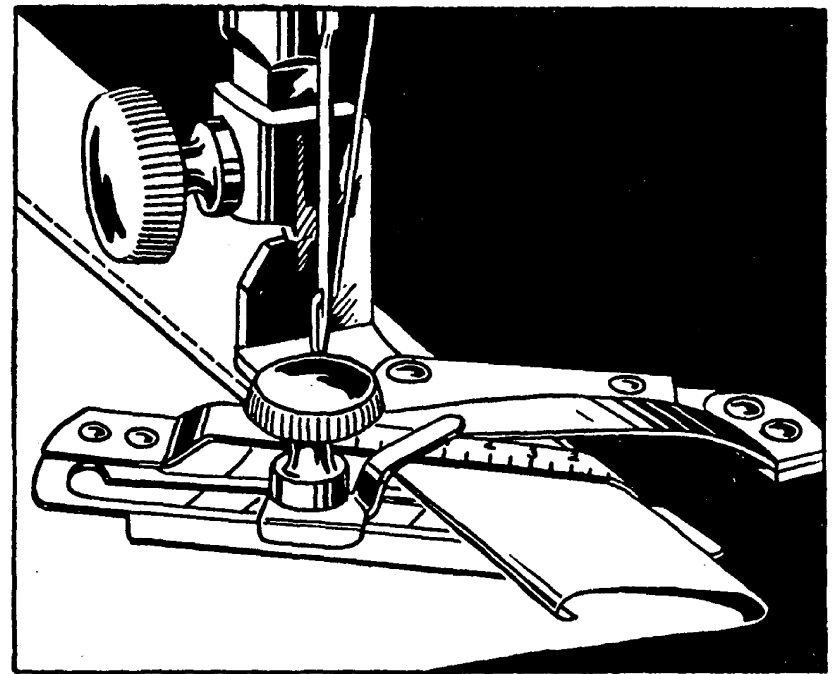

Fig. 45. Hemming and Sewing on Lace

ADJUSTABLE HEMMER

To Make Hems from $\frac{3}{16}$ to $\frac{15}{16}$ Inch Wide

1. Attach adjustable hemmer to presser bar in place of presser foot.
2. Pull up bobbin thread, as instructed on page 16.
3. Loosen thumb screw on hemmer and move scale until pointer registers with number of desired width of hem. (No. 1 indicates the narrowest hem and No. 8, the widest.) Then tighten thumb screw.
4. Place cloth in hemmer and draw it back and forth until hem is formed, as shown in Fig. 46.
5. Draw end of hem back under needle, lower presser bar and start to sew.
6. Guide sufficient cloth into hemmer to turn hem properly.



*Fig 46. Making Hem Up to $\frac{15}{16}$ Inch Wide
With Adjustable Hemmer*

MULTI-SLOTTED BINDER

This multi-slotted binder will apply **unfolded bias binding** $\frac{15}{16}$ inch in width and **commercial folded binding** in sizes 1, 2, 3, 4 and 5 to seams or to edges of garments. These sizes of folded binding are $\frac{1}{4}$, $\frac{5}{16}$, $\frac{3}{8}$, $\frac{7}{16}$ and $\frac{1}{2}$ inch in width, respectively, and are fed through slots of corresponding sizes in the binder scroll. See Fig. 47. Binding may be purchased in a variety of materials and colors.

For convenience in determining the correct width of **unfolded binding** ($\frac{15}{16}$ inch), this measurement is marked on the binder, as shown in Fig. 47.

The two upright guide pins, shown in Fig. 47 eliminate manual guiding of the binding.

The wide range of bindings that can be applied with this binder makes it useful for a large variety of work. It will be

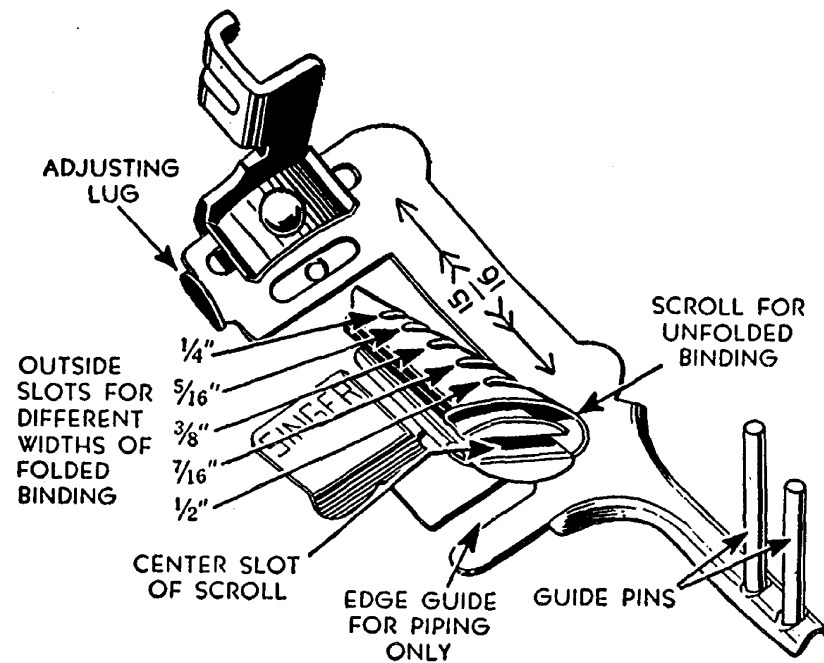

Fig. 47. Multi-Slotted Binder 160359

found particularly advantageous for making children's wear, lingerie, summer dresses, and other dainty articles which call for narrower bindings.

As two different widths of binding of contrasting colors can be fed through binder at same time, attractive binding and piping effects can be produced in one operation.

To Attach the Binder

Raise needle to its highest position. Then attach binder to presser bar in place of presser foot.

See that needle enters center of needle hole.

To Insert Binding In Binder

Cut all binding to a long point to the left, as shown in **Fig. 48**.

Folded bias binding must be inserted in the slot or slots of corresponding sizes. See **Fig. 51**.

Unfolded or raw edge bias binding must be inserted in the open end of the scroll. See **Fig. 49**.

After inserting pointed end of binding in binder, push it through until full width of binding is under needle.

Guide binding by means of two upright pins, as shown in **Figs. 49 to 53**.

To Insert Garment in Binder

Place edge to be bound as far to right as it will go in center slot of scroll C2, as shown in **Fig. 49**, and draw it back under binder foot.

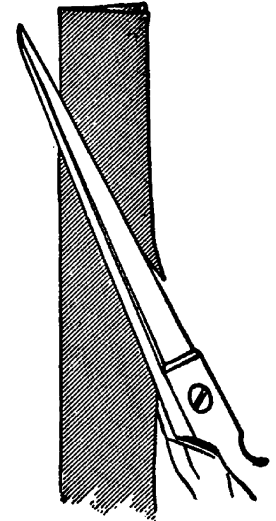

Fig. 48

Lower binder by means of presser foot lifter, and start to sew. Keep material

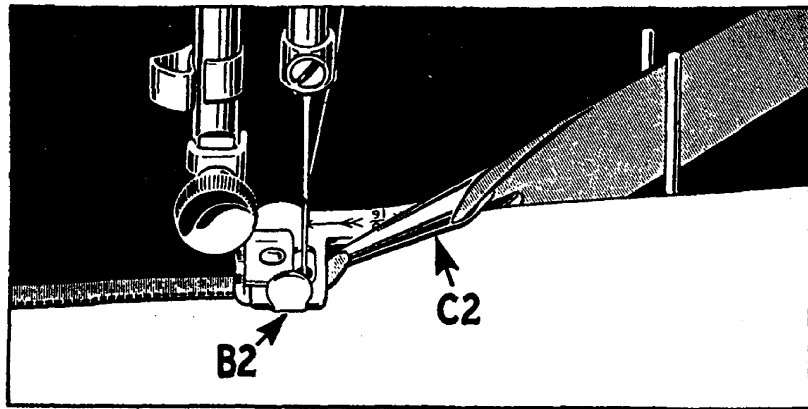

Fig. 49. Binding with Unfolded Binding

well within center slot of scroll so that edge will be caught in binding.

To Adjust the Binder

To bring inner edge of binding closer to the stitching, move scroll C2, Fig. 49

to the right by means of lug B2, Fig. 49. This is the usual adjustment when binding straight edges.

When binding curves, move scroll to left to bring inner edge of binding farther from stitching and allow for sweep of curve.

Piped Edge

To produce a piped edge on garments, move lug B2, Fig. 50 to left to bring

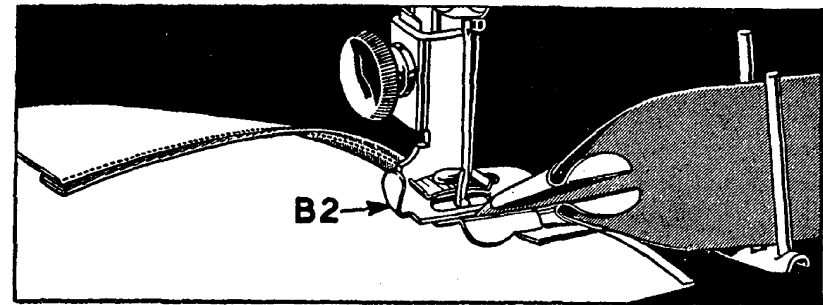

Fig. 50. Position of Garment and Binding When Piping Edges

stitching about midway of folded binding.

Crease raw edges of garment toward wrong side about $\frac{1}{8}$ inch, and insert folded edge, raw edges uppermost, into edge guide on binder, and beneath binding.

When stitched, both sides of garment will be finished, and right side will show piped edge.

Piping and Binding in One Operation

A garment can be piped and bound in one operation, as shown in Fig. 51.

IMPORTANT: When piping and binding at same time, as shown in Fig. 51, insert narrow width of binding first in its slot, then insert wider width in its slot. Two consecutive widths should not be used at same

time. That is, if No. 1 is used, wider binding should not be smaller than No. 3. If No. 2 is used, wider binding should not be less than No. 4. **Never use Nos. 1 and 2, or 2 and 3, etc., together.**

Use the upright guide pins to guide the wider of the two widths of binding, as shown in Fig. 51.

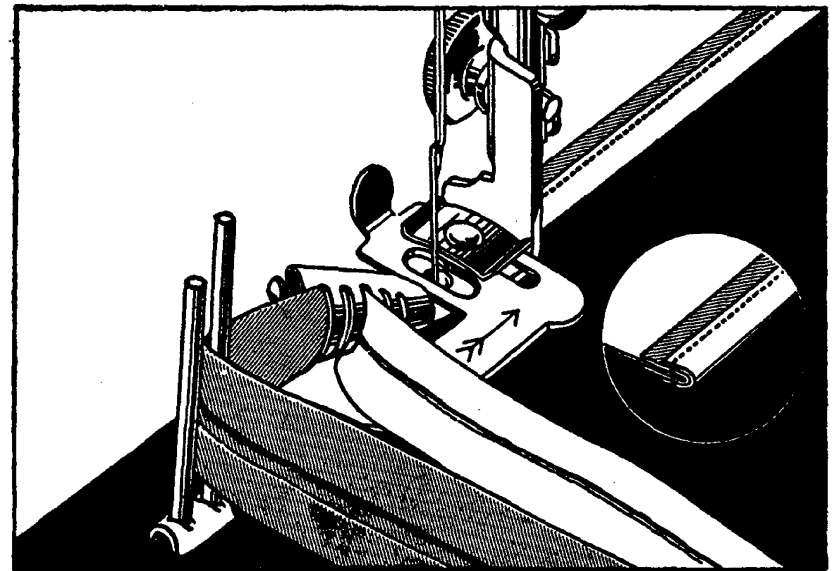

Fig. 51. Piping and Binding in One Operation

To Bind Outside Curves

Allow edge to be bound to pass freely through scroll without crowding against scroll wall. The material must be guided from back of binder and to left, permitting unfinished edges to swing naturally into scroll of binder.

Never pull binding while it is being fed through binder, as this may stretch binding, making it too narrow to stitch or to turn in the edges.

When binding curves, turn material only as fast as machine sews.

Do not push material in too fast as this will pucker edge.

Do not stretch material as this will distort edge so that curve will not have proper shape when finished.

If stitching does not catch edge of binding, adjust scroll slightly to the left.

To Bind Inside Curves

When binding an inside curve, straighten out edge of material while feeding it into binder, being careful not to stretch material.

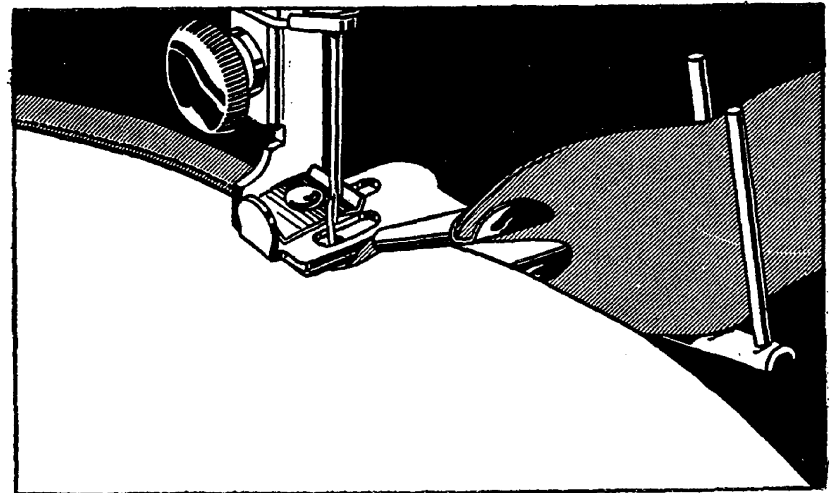

Fig. 52. Binding an Outside Curve

Soft materials, like batiste or crepe de chine, require a row of stitching added close to edge of curve before binding.

To Apply French Folds to Curves

Place material under binder and stitch binding onto face of material, as shown in Fig. 53.

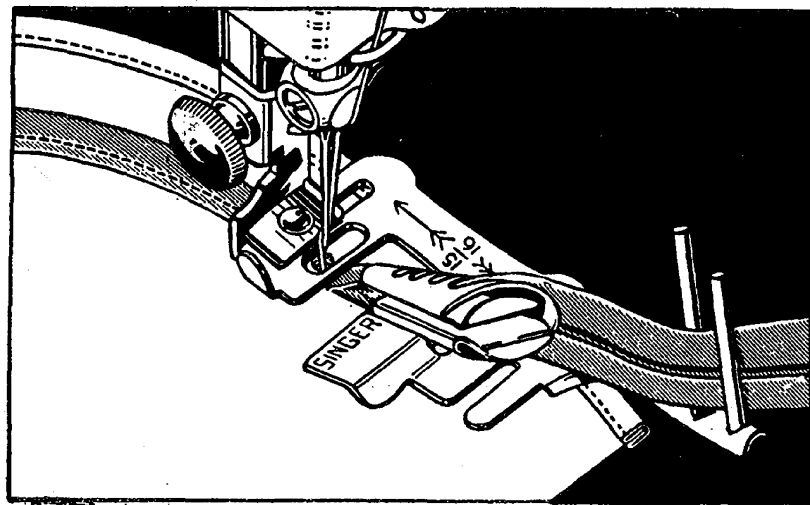

Fig. 53. Applying a French Fold

For guidance in applying rows of French folds, mark material with a line of basting stitches or with chalk or pencil.

THE EDGE-STITCHER

This useful attachment is fastened to machine in place of presser foot, and will be found an indispensable aid whenever stitching must be kept accurately on extreme edge of a piece of material. The slots, numbered from 1 to 5

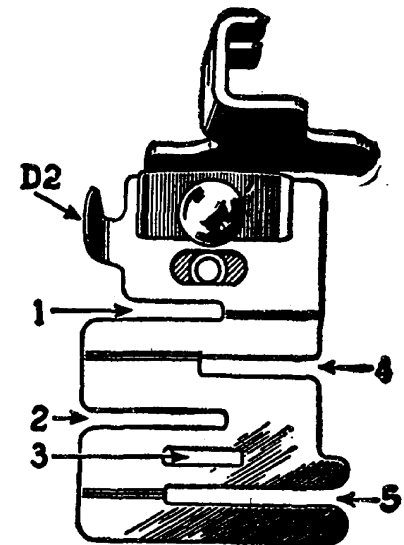

Fig. 54
The Edge-Stitcher

in Fig. 54, serve as guides for sewing together laces, insertions and embroideries, sewing in position hemmed or folded edges, piping or sewing flat braid to a garment.

To Adjust the Edge-Stitcher

Fasten this attachment to presser bar in place of presser foot.

Turn hand wheel slowly by hand to see that needle goes through center of needle hole.

The distance from line of stitching to edge of material in slots is regulated by moving lug **D2**, Fig. 54 to right or left. If lug moves with difficulty, place a drop of oil under blue spring, then wipe it dry.

To Sew Lace Together

1. Insert one of the laces in slot 1 of edge-stitcher and the other in slot 4, Fig. 54.

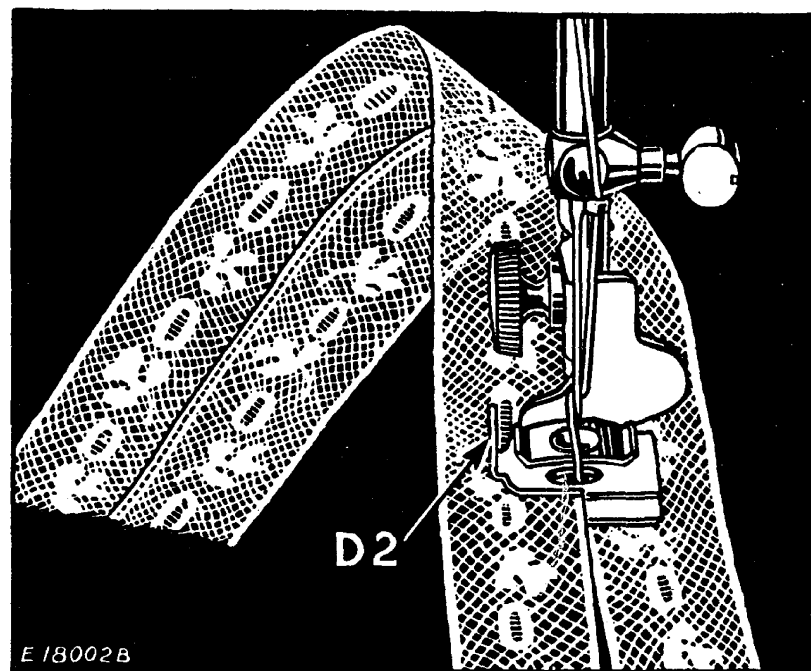

Fig. 55. Sewing Lace Together

2. Adjust lug **D2** until edges to be joined are caught by the stitching.
3. Slightly overlap edges of lace while stitching to keep them against ends of slots.
4. Loosen both thread tensions to avoid puckering of fine lace.

To Insert Lace or Ribbon

1. Fold edge of material to which lace or ribbon is to be sewn and insert it in slot 1, **Fig. 54** of edge-stitcher.

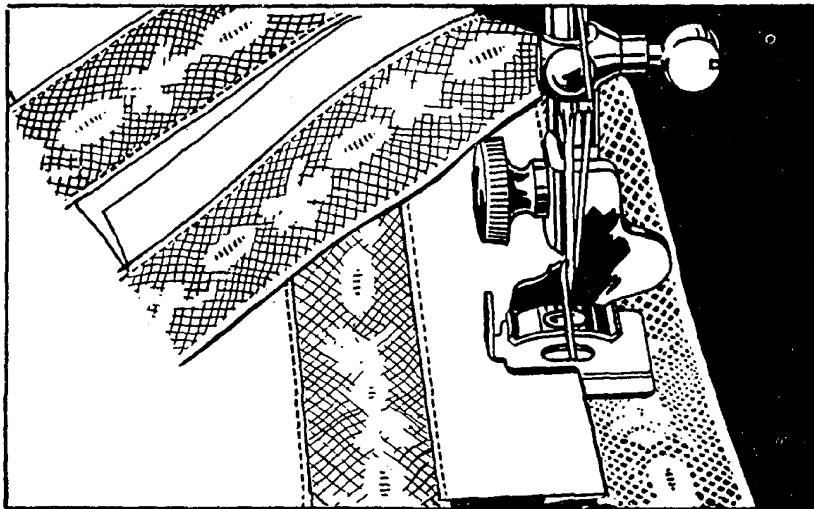

Fig. 56. Setting in Lace Insertion

2. Insert lace or ribbon in slot 4 of edge-stitcher and proceed to sew.
3. Cut away surplus folded material close to stitching.

To Pipe with Edge-Stitcher

1. Cut piping bias and twice width of slot 3 so that it can be folded once.
2. Insert piping with its folded edge to left in slot 3 and edge to be piped in slot 4, **Fig. 54**.

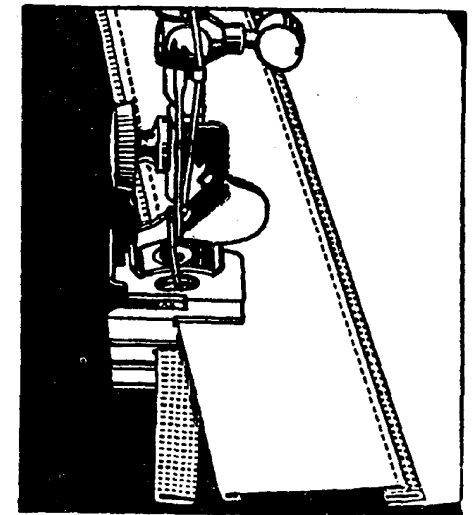

Fig. 57. Piping with Edge-Stitcher

To Apply Folded Bias Tape or Military Braid

1. Place garment under edge-stitcher and tape in slot 1 or 4, Fig. 54.
2. To make square corners, sew to turning point, remove tape from attachment, form corner by hand, replace tape and continue stitching. See Fig. 58.
3. To space two or more parallel rows, mark material with a guide line, using a crease, chalk or basting thread.

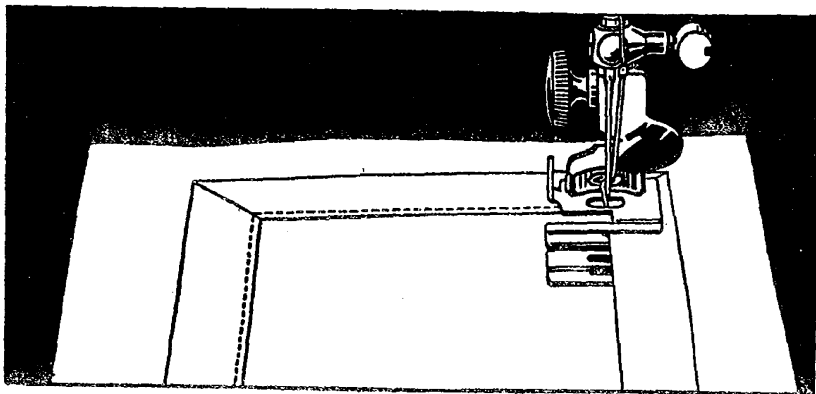

Fig. 58. Applying Bias Folded Tape

To Stitch a Wide Hem

1. A wide hem may be stitched evenly on sheets, pillow slips, etc., with edge-stitcher after hem has been measured and edge turned.
2. Insert edge in slot 5, Fig. 54, and adjust lug D2 to stitch as close to edge as desired.

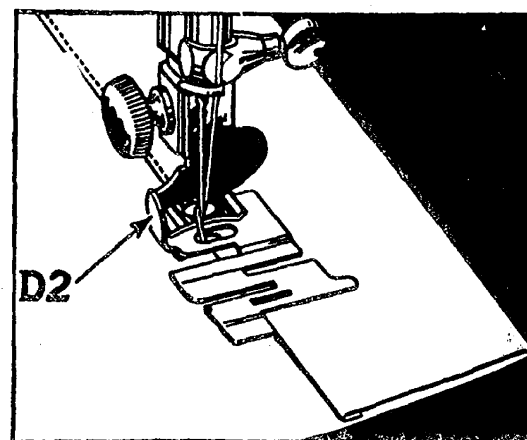
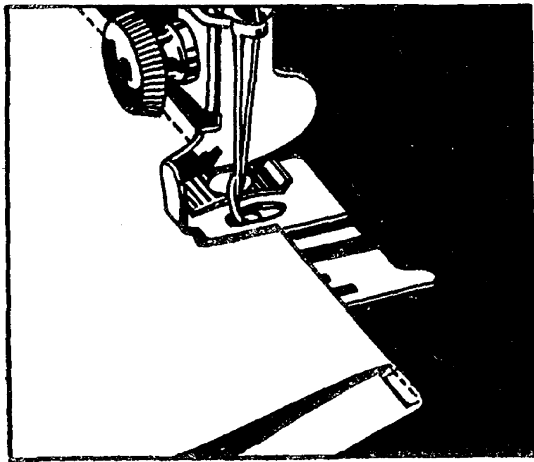

Fig. 59. Making a Wide Hem

To Make a French Seam

1. To make a French seam of uniform width, insert two edges to be joined, wrong sides together, in slot 1 or 2, Fig. 54, and stitch close to edge.
2. Fold both right sides together and insert back of seam in slot 1, as shown in Fig. 60, and stitch, allowing just enough margin to conceal raw edges.



*Fig. 60. Making a French Seam
(Second Operation)*

To Tuck with Edge-Stitcher

The maximum width of tuck that can be made with edge-stitcher is $\frac{1}{8}$ inch.

1. Fold and crease material for desired width of tuck.

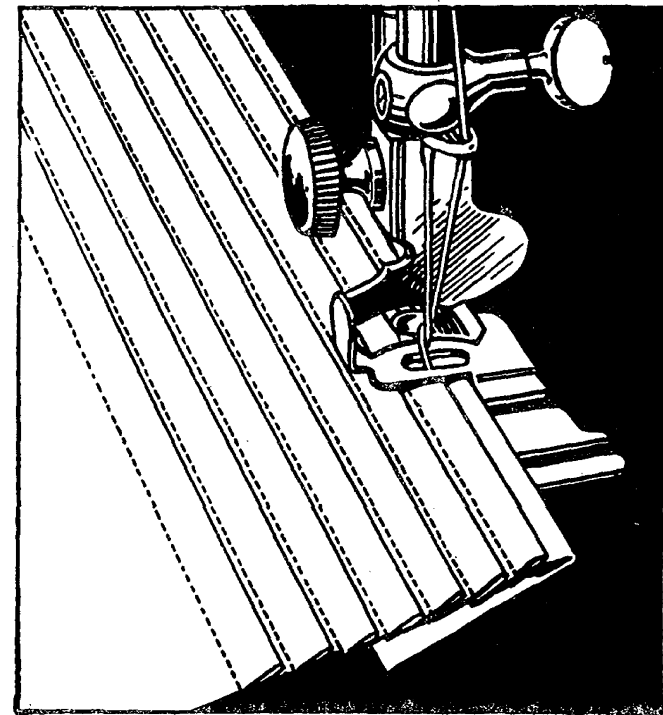

Fig. 61. Tucking with Edge-Stitcher

2. For succeeding tucks, fold material the desired distance from previous tuck, running the fold lengthwise over a straight edge, then crease folds.
3. Insert creased folds in slot 1, Fig. 54 and adjust edge-stitcher to right or left for the desired width of tuck. Use a light tension, short stitch and fine thread and needle.

GATHERING FOOT

To Shirr with Gathering Foot

1. Fasten gathering foot to presser bar in place of presser foot.
2. Place material under gathering foot and stitch in usual way.

3. The fullness of shirring or amount of gathering is regulated by length of stitch. A longer stitch increases fullness of gathers.

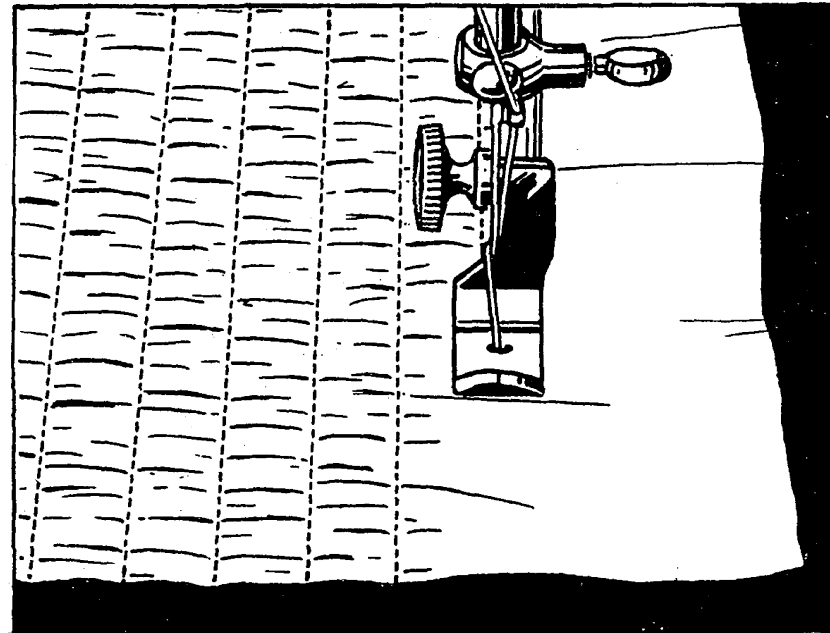

Fig. 62. Shirring with Gathering Foot

THE RUFFLER

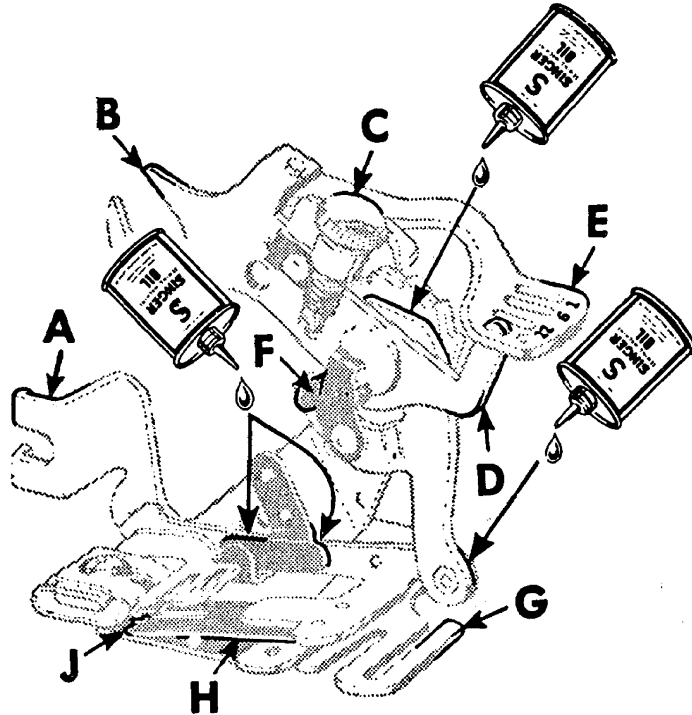

Fig. 63. Principal Parts of Ruffler

Lubrication

At the beginning of each working day lubricate Ruffler to insure smooth operation and to prevent jamming, rust and wear.

Apply one drop of oil at each point indicated in Fig. 63. Wipe off excess

oil. Insert scrap of material in Ruffler and operate attachment until no oil appears on work.

Principal Parts

- A—Foot—attaches ruffler to presser bar.
- B—Fork Arm—straddles needle clamp.
- C—Adjusting Screw—regulates fullness of gathers.
- D—Projection—engages slots in adjusting lever.
- E—Adjusting Lever—sets ruffler to gather or pleat once every 6 stitches or once every 12 stitches or not at all, as desired.
- F—Adjusting Finger—regulates width or size of pleats.
- G—Separator Guide—edge of material placed in slots to keep heading of ruffle even. Separates ruffling material from material to which ruffle is being attached.
- H—Ruffling Blade—pushes material; forms pleats and pushes material toward needle.

J—Separator Blade—prevents ruffling blade teeth from damaging material or feed.

To Attach Ruffler

1. Raise needle to its highest point.
2. Loosen presser foot thumb screw and attach ruffler to presser bar in place of presser foot, at same time placing fork arm **B** astride needle clamp.
3. See that needle enters center of needle hole in ruffler.

To Adjust Ruffler for Gathering

1. Swing adjusting finger **F** away from needle.
2. Raise adjusting lever **E** and move it until projection **D** can be entered in slot marked "1".

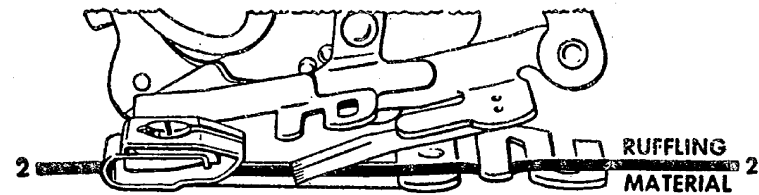

Fig. 64. Correct Position for Material to be Ruffled

3. Insert material to be ruffled between two blue blades **Line 2**, Fig. 64.

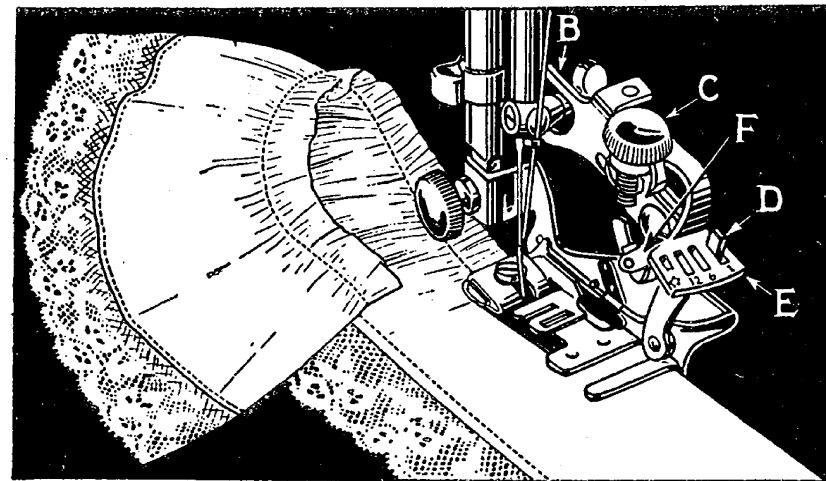

Fig. 65. Gathering with Ruffler

4. Draw material slightly back of needle, lower presser bar and start to sew.
5. For fine gathering, turn adjusting screw C upward and shorten stitch.
6. For full gathering, turn adjusting screw C downward and lengthen stitch.

To Make a Ruffle and Sew It to a Garment In One Operation

1. Insert material to be ruffled between two blue blades Line 2, Fig. 66.

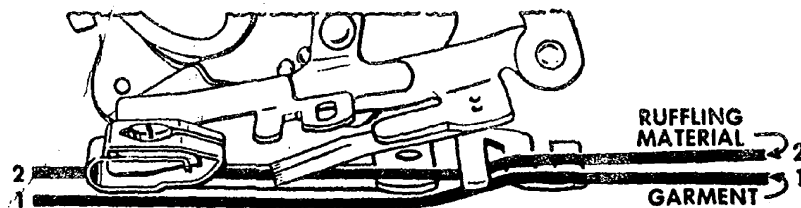

Fig. 66. Correct Positions for Materials

2. Place material to which ruffle is to be attached under separator blade Line 1, Fig. 66.
3. Proceed same as for plain gathering.

To Make a Ruffle and Attach It With a Facing in One Operation

1. Insert material to be ruffled between two blue blades Line 2, Fig. 68.

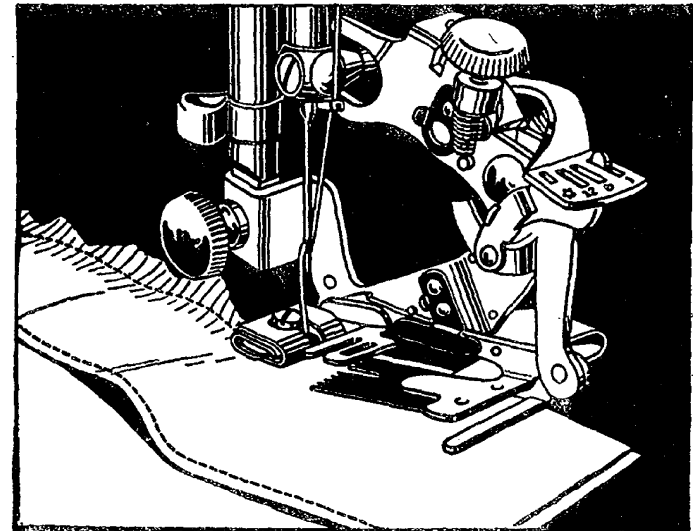

Fig. 67. Making a Ruffle and Attaching It In One Operation

2. Place material to which ruffle is to be attached under separator blade **Line 1, Fig. 68.**
3. Place facing material over upper blue blade **Line 4, Fig. 68.**

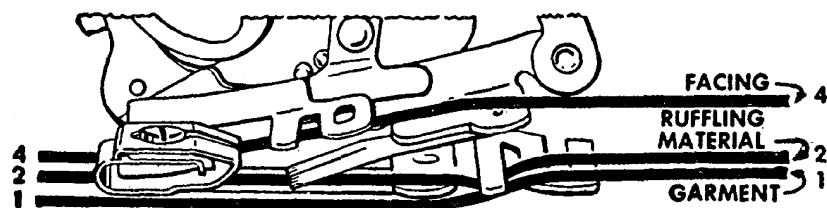

Fig. 68. Correct Positions for Materials

4. If facing is to be on right side of garment, place wrong sides of garment and ruffle together.
5. If facing is to be on wrong side, place right sides of garment and ruffle together.

To Pipe a Ruffle

1. Insert material to be ruffled between two blue blades **Line 3, Fig. 70.**

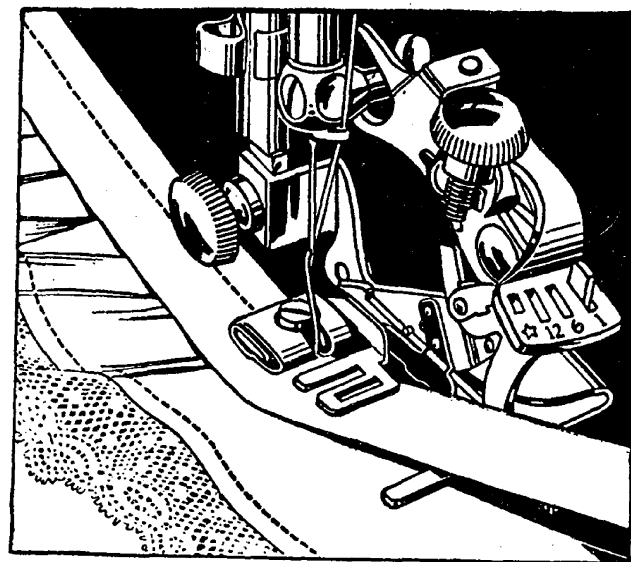

Fig. 69. Making a Ruffle and Attaching It With a Facing In One Operation

This material must not exceed $1\frac{1}{4}$ inches in width.

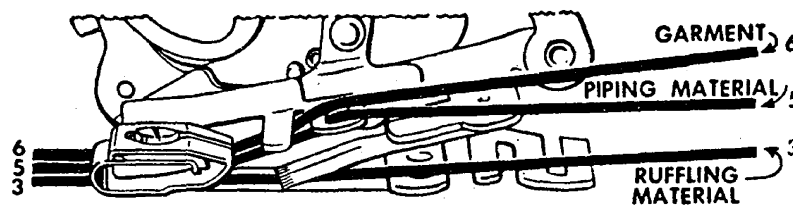

Fig. 70. Correct Positions for Materials

2. Piping material is usually cut on the bias and it should be about $\frac{1}{4}$ inch wide when folded in center. Place piping material in ruffler, following **Line 5, Fig. 70** with folded edge of piping to the right.
3. Fold edge of material to which piping and ruffling are to be attached

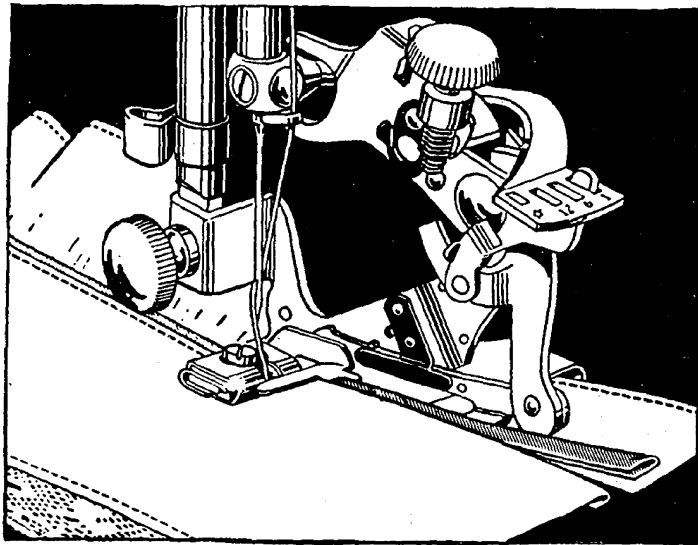

Fig. 71. Piping a Ruffle

and insert it in ruffler, following **Line 6, Fig. 70**.

To Adjust Ruffler for Pleating

1. Raise adjusting lever **E** and move it until projection **D** can be entered in slot marked "6". The ruffler will then pleat once every six stitches. To pleat once every 12 stitches, have projection **D** enter slot "12" in adjusting lever **E**.
2. Insert material to be pleated between two blue blades **Line 2, Fig. 72**.

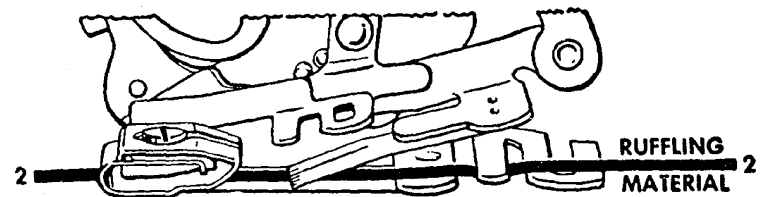

Fig. 72. Correct Position for Material

3. To increase width of pleat, move adjusting finger **F** back toward needle and turn adjusting screw **C** downward. To make a smaller pleat, turn adjusting screw **C** upward. The distance between pleats is regulated by length of stitch.

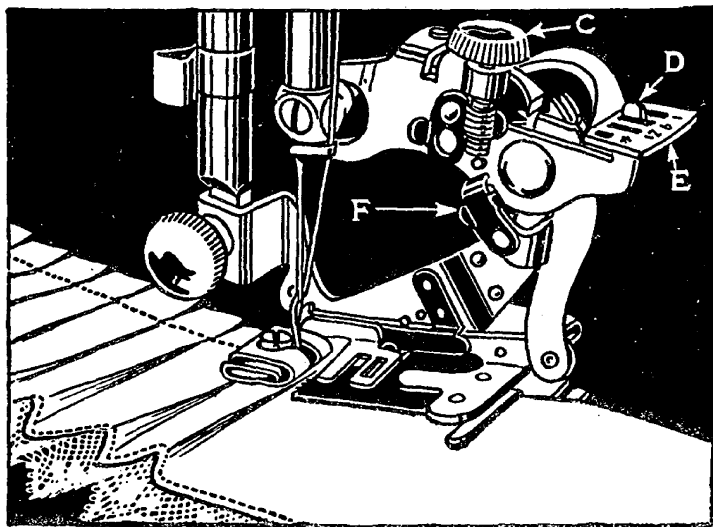

Fig. 73. Pleating with the Ruffler

To Adjust Ruffler for Group Pleating

1. To make the space between groups of pleats, raise adjusting lever **E** and move it until projection **D** can be entered in small slot indicated by star on adjusting lever **E**. The ruffler will then stop pleating and plain stitching will be made.

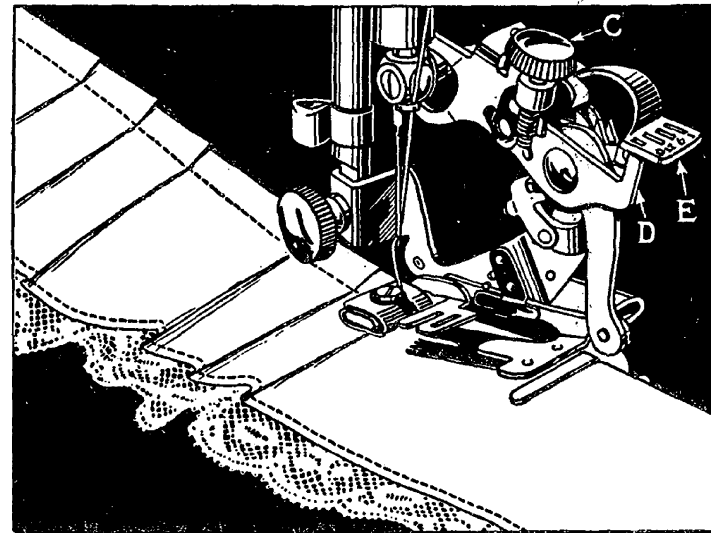

Fig. 74. Group Pleating with Ruffler

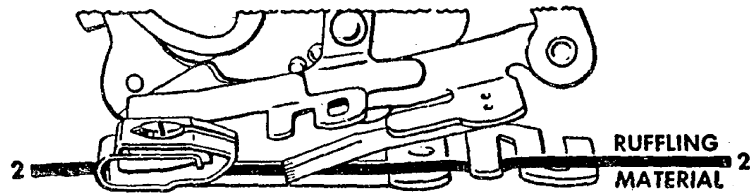

Fig. 75. Correct Position for Material

2. When the desired space is made, set projection **D** in either of slots 6 or 12.

3. Insert material to be pleated between two blue blades **Line 2, Fig. 75.**

FASHION AIDS

The following FASHION* Aids are available for separate purchase at your SINGER SEWING CENTER.

Automatic Zigzagger

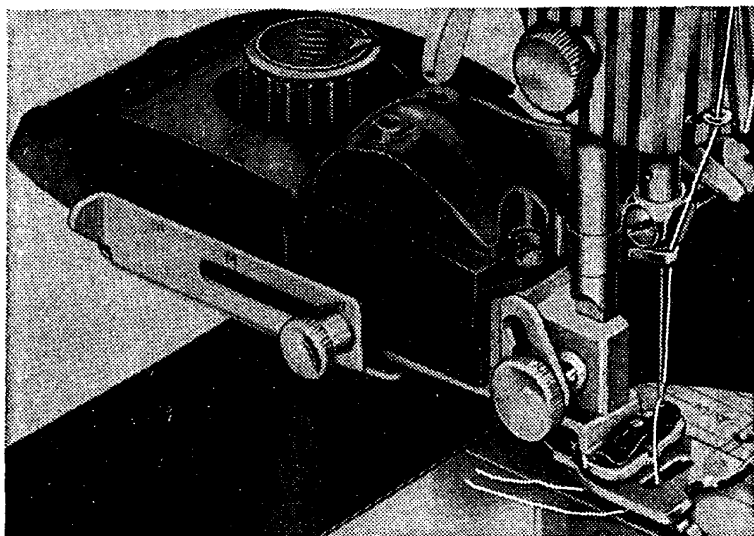

Zigzag stitching, decorative pattern stitching, applique—all of these and more may be done *automatically* on your SINGER with the Automatic Zigzag Attachment.

You can blindstitch hems, mend rips and tears, reinforce seams, overedge seam edges and stitch scallop facing easily and quickly.

Merely insert one of the many Stitch Patterns into the Automatic Zigzagger and sew.

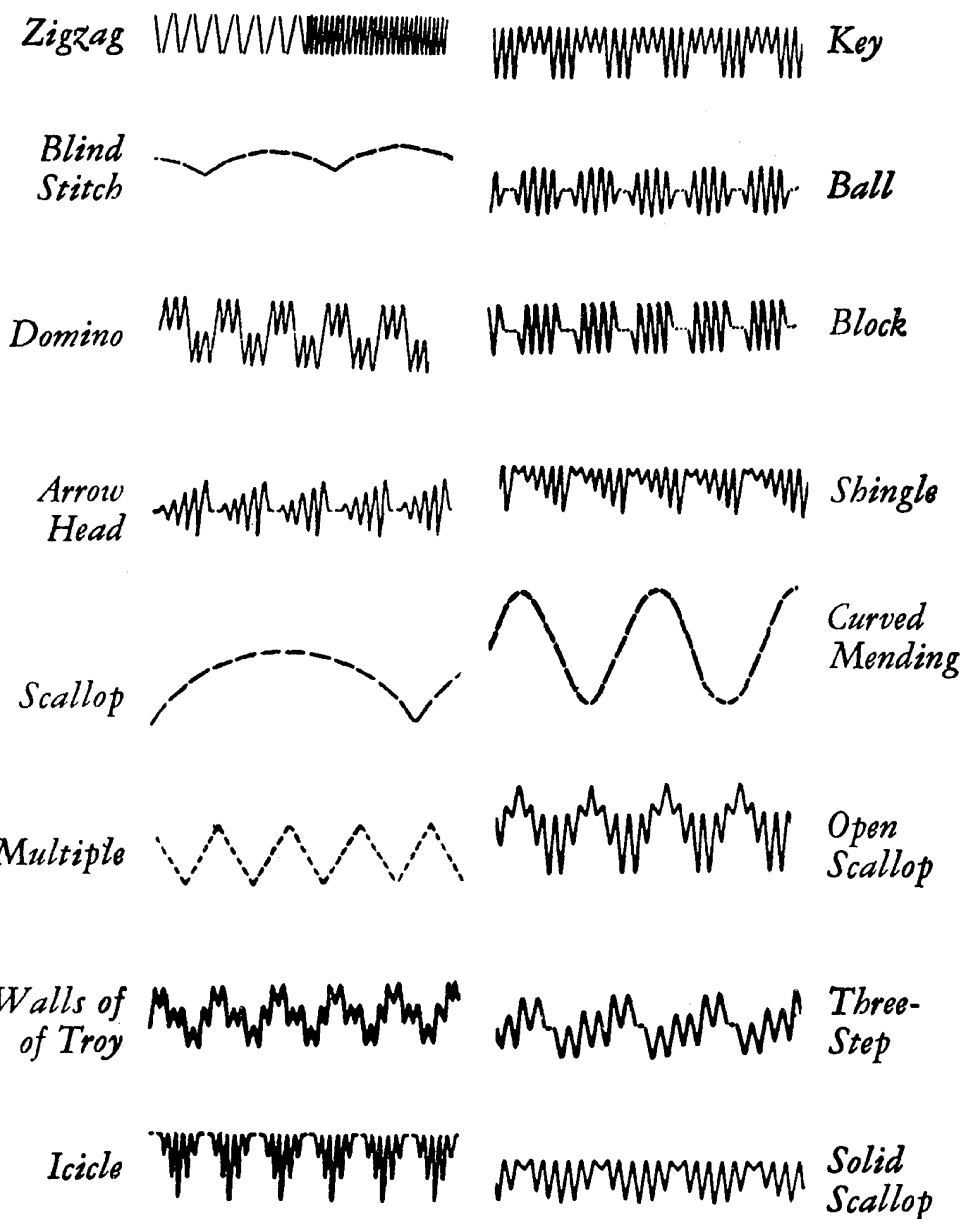

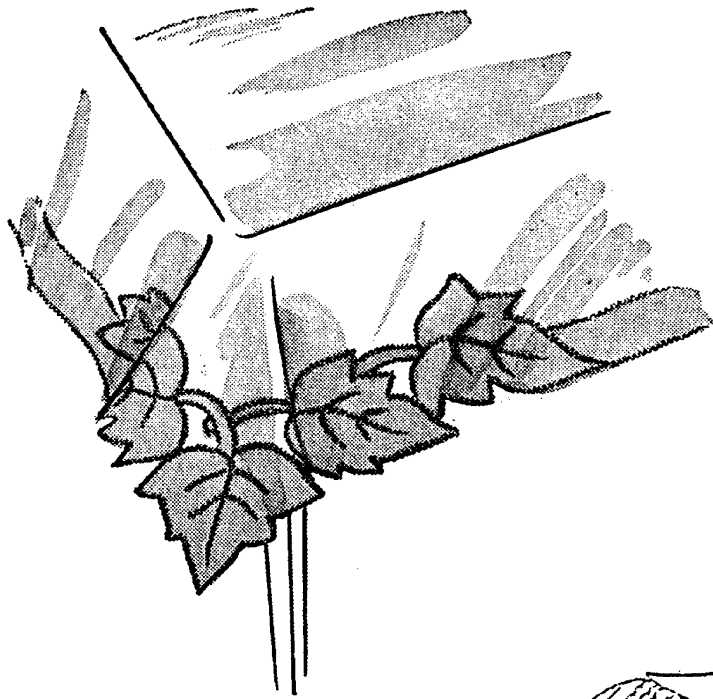

*Appliqued
Table Cloth Border*

*Blouse with Blindstitch
Border Design*

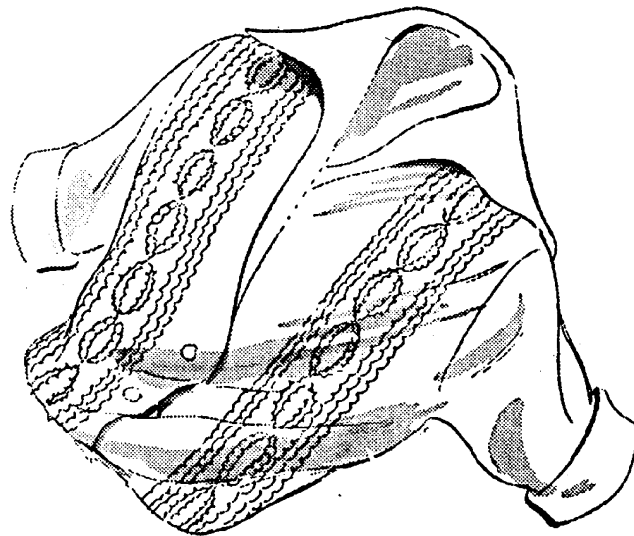

*Girls' Dress with
Border Design in Domino Pattern*

The Buttonholer

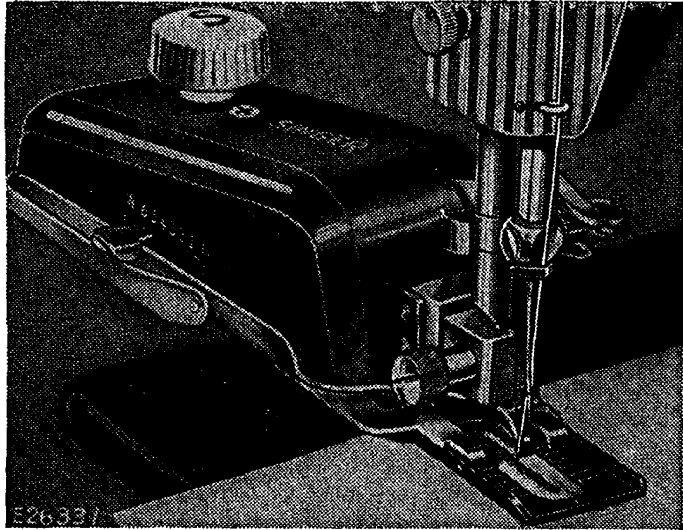

Beautiful, evenly stitched buttonholes may be made on your SINGER Machine with the Buttonholer, as easily as you do straight stitching.

Merely slip the template, for the size buttonhole you require, into the attachment and replace the presser foot with the Buttonholer. Every buttonhole will

*Sample of
Work
Produced
by SINGER
Buttonholer*



be identical. The Buttonholer does the work for you—straight buttonholes in seven lengths: $\frac{5}{16}$ " , $\frac{3}{8}$ " , $\frac{1}{2}$ " , $\frac{5}{8}$ " , $\frac{13}{16}$ " , $\frac{15}{16}$ " and $1\frac{1}{16}$ " ; keyhole, in two lengths: $\frac{5}{8}$ " and $1\frac{1}{16}$ " .

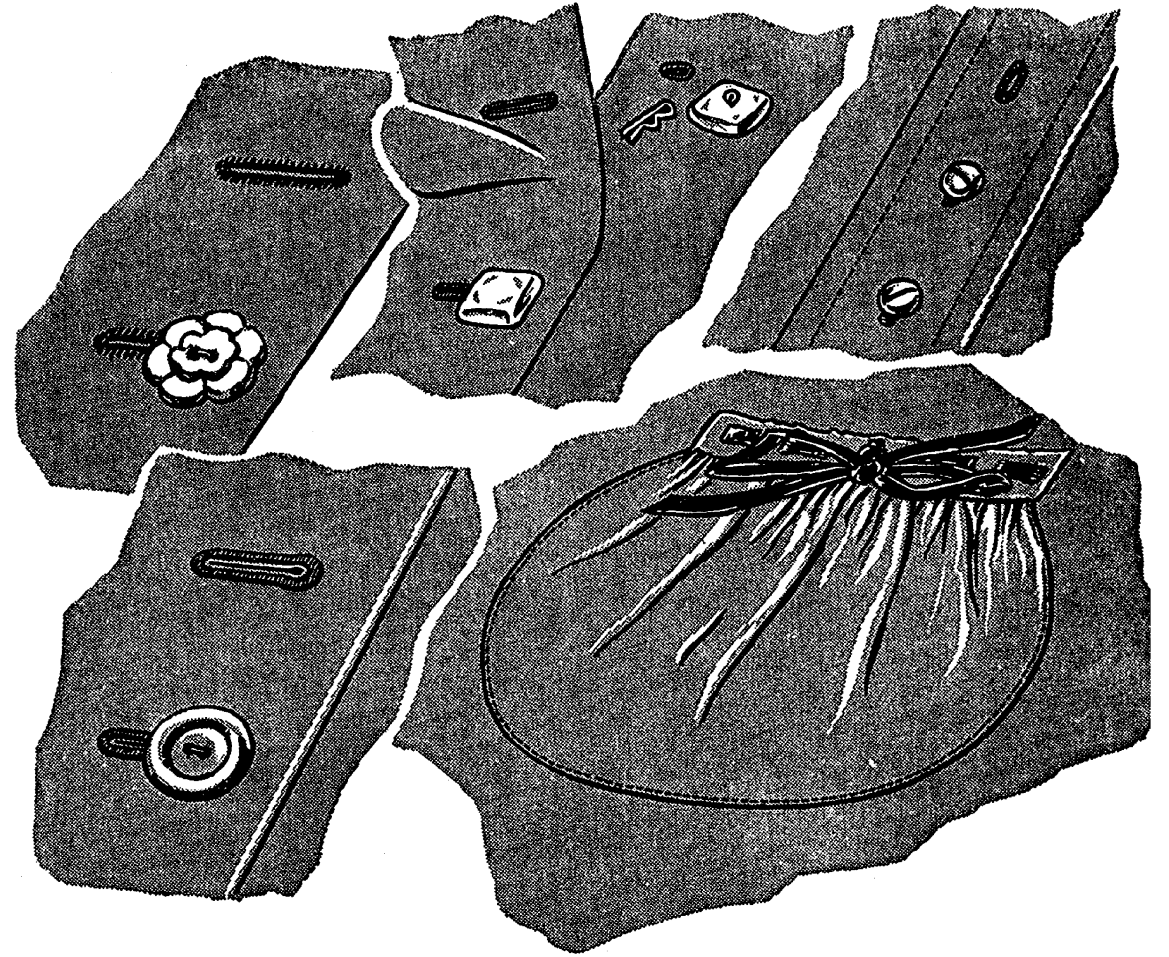

Samples of Work Produced by SINGER Buttonholer

Darning and Embroidery Attachment

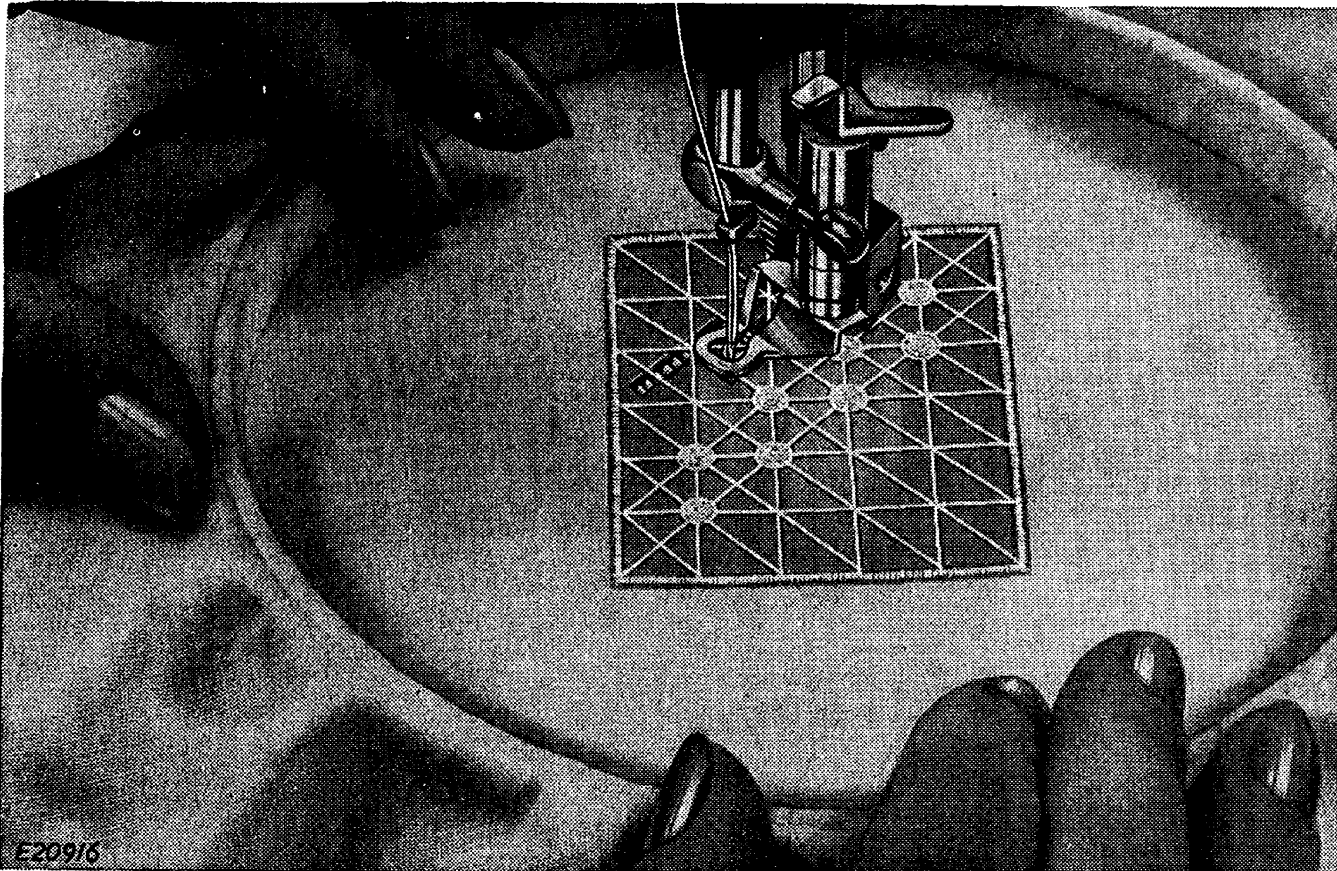

The Web Lace Stitch

The Darning and Embroidery Attachment contributes to the ease with which free-motion sewing is accomplished. Lovely embroidered effects are possible on a wide range of fabrics.

The foot merely holds the fabric down while the stitch is being formed and releases the fabric when the needle has risen to allow free movement of the work for variety of embroidery effects.

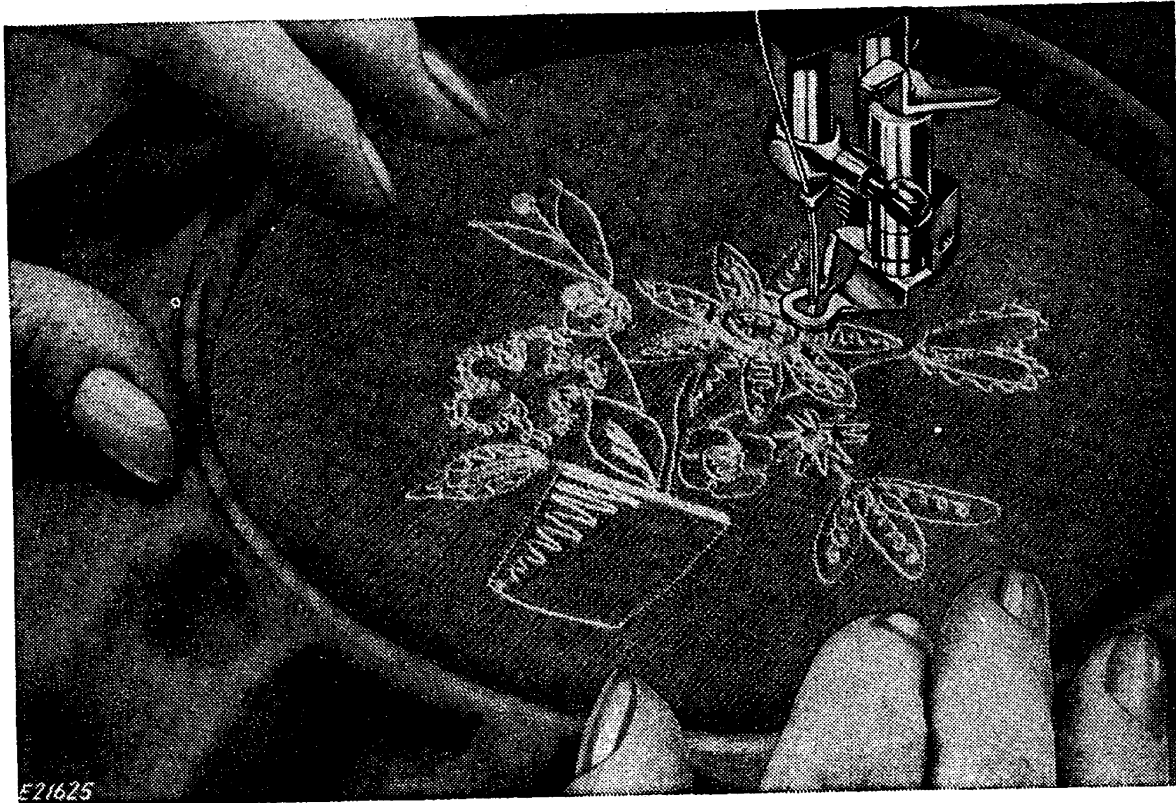

The Tracing Stitch

The Darning Stitch

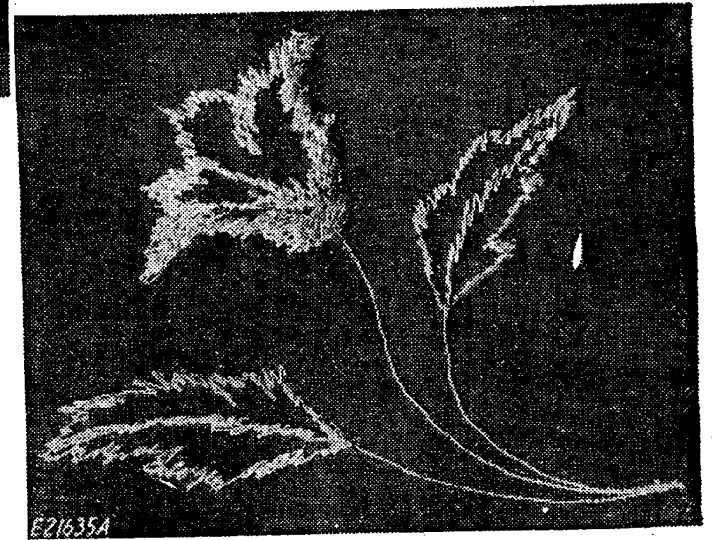

Seam Guide

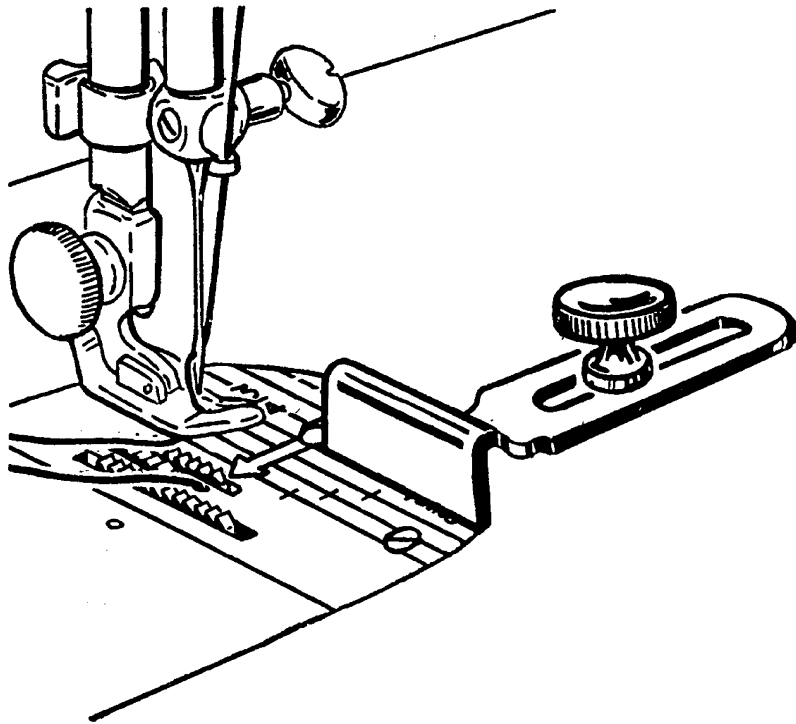

The Seam Guide

The Seam Guide is helpful in stitching seams an exact width, and for stitching a uniform distance from a finished edge.

Especially helpful for those just learning to sew and an aid to those demanding greater uniformity in seam width than the eye might give, the seam guide is a useful addition to your sewing equipment.

The scoring on the throat plate of your SINGER Machine makes it easy for you to set the Seam Guide to an exact distance from the needle.

Gauge Presser Foot

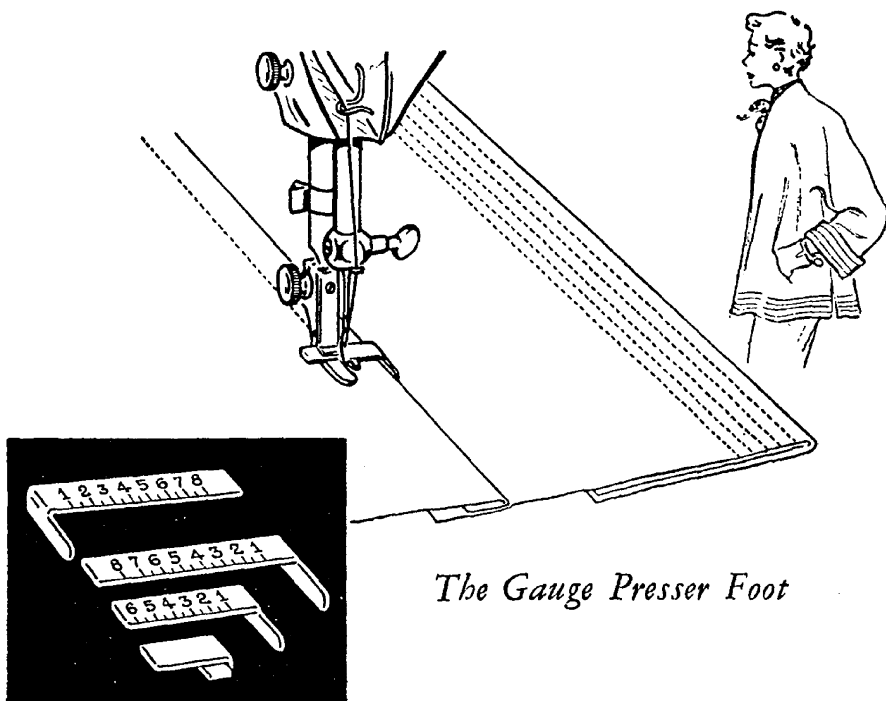

The Gauge Presser Foot

Expert and beautiful stitching is accomplished with a minimum of skill and preparation through the use of the SINGER Gauge Presser Foot. Single or

multiple rows of stitching may be gauged evenly along lapel and facing edges, welt seams, or hems.

An accurate set of gauges (lined at $\frac{1}{8}$ " and numbered at $\frac{1}{4}$ " intervals)—one for use at the left of needle and three for use at right of the needle, accompany the Gauge Presser Foot.

The side walls of the gauges vary in depth to accommodate fabrics and constructions of different thickness. Smart, even stitching accents are effectively placed with the Gauge Presser Foot.

INDEX

	Page		Page
Attachments.....	40	Principal parts of Machine 201-2.....	4
Adjustable hemmer.....	45	Reassembling and replacing needle thread	
Edge-stitcher.....	51	tension.....	26, 27
Foot hemmer.....	41	Regulating bobbin thread tension.....	24, 25
Gathering foot.....	56	Regulating direction of feed.....	19
Multi-slotted binder.....	46	Regulating needle thread tension.....	22, 23
Ruffler.....	57	Regulating pressure on presser foot.....	20, 21
Basting.....	19	Regulating stitch length.....	18
Cleaning stitch forming mechanism.....	38	Removing and disassembling needle thread	
Darning and Embroidering.....	30, 31, 32	tension.....	26
Electrical information.....	5	Removing the bobbin.....	12
Fashion Aids.....	63	Removing the bobbin case.....	38
Buttonholer.....	66, 67	Removing the work.....	18
Darning and Embroidery Attachment.....	68, 69	Replacing the bobbin.....	15
Gauge Presser Foot.....	71	Replacing the bobbin case.....	39
Seam Guide.....	70	Setting the needle.....	8
Zigzagger, Automatic.....	64, 65	Sewing bias seams.....	19
Light.....	6, 7	Sewing suggestions.....	28, 29
Lubricating the motor.....	37, 38	SINGER Service.....	3
Machine working heavily.....	29, 36	Starting to sew.....	17
Motor.....	5	Threading the bobbin.....	15
Needle chart.....	9	Thread tension.....	22
Needles and thread.....	8	Turning a corner.....	19
Oiling the machine.....	33-36	Upper threading.....	11
Operating the machine.....	10	Winding the bobbin.....	12, 13, 14
Preparing to sew.....	16		

TO ALL WHOM IT MAY CONCERN

The improper placing or renewal of the Trademark "SINGER" or any other of the Trademarks of The Singer Company (all of which are duly Registered Trademarks) on any machine that has been repaired, rebuilt, reconditioned, or altered in any way whatsoever outside a SINGER factory or an authorized SINGER agency is forbidden.

For your protection

SINGER Sewing Machines are sold and serviced wherever you see the famous SINGER and Red "S" Trademarks. When your machine needs servicing call your SINGER SEWING CENTER to be sure of warranted SINGER parts and service. See address in the classified telephone directory.

T H E S I N G E R C O M P A N Y