

# Instructions

*Stylist*

ZIG-ZAG SEWING MACHINE/MODEL 413

**SINGER**

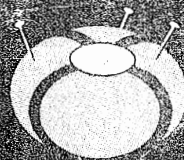
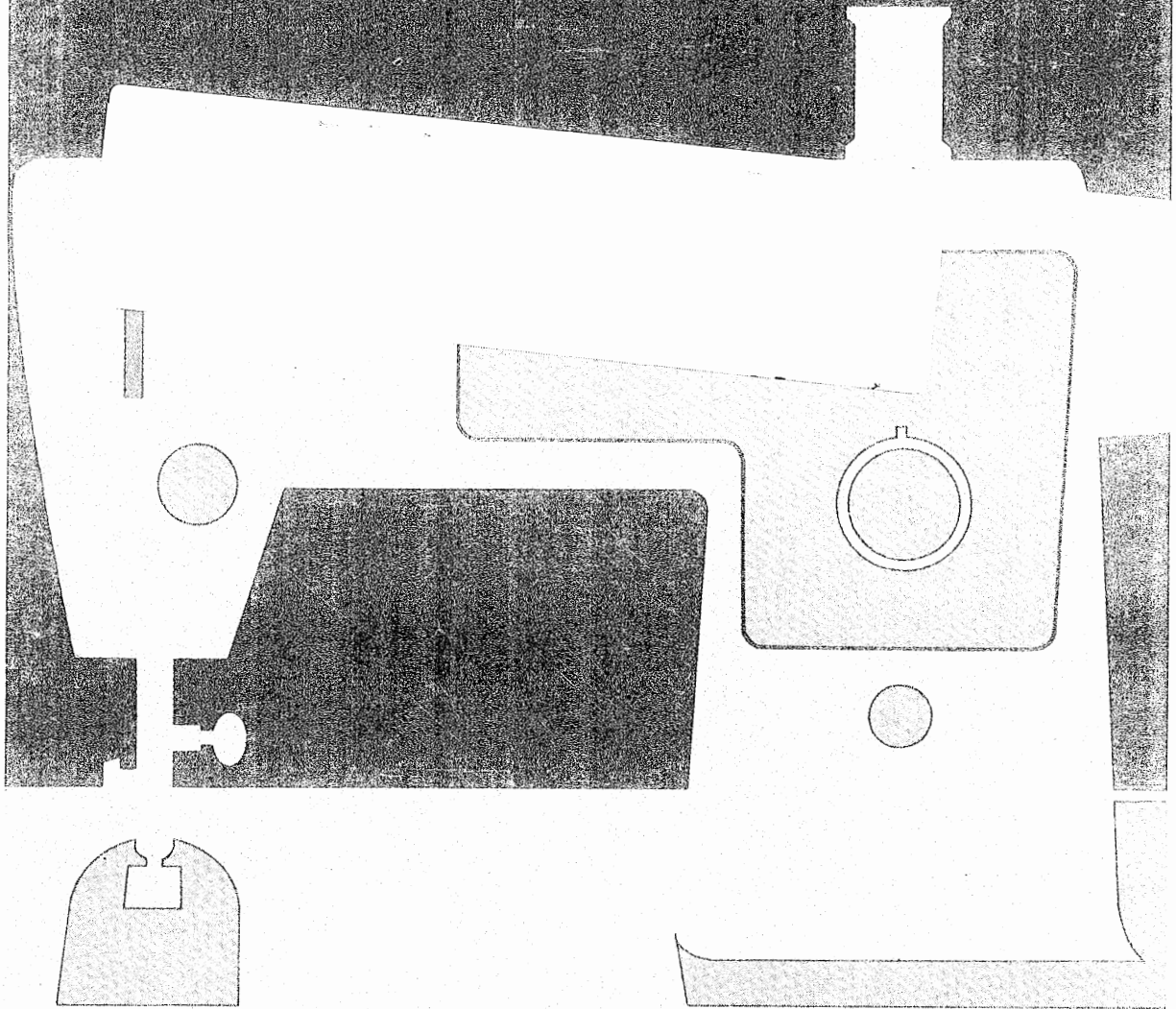

## *Congratulations!*

As the owner of the *Stylist*\* Zig-Zag Sewing Machine by SINGER, you are about to enter a wonderful new world of sewing! From the moment you begin to sew on your sewing machine, you will be delighted with its easy, dependable operation.

- Perfect straight stitching.
- Practical stretch stitching with *Flexi-Stitch*\* patterns.
- Useful zig-zag stitching.
- Time-saving blindstitching.
- Twin-needle stitching for those extra finishing touches.

May we recommend that before you begin to sew, you discover all the many advantages of your *Stylist* machine by going through this instruction book step by step while seated at your machine.

SINGER\* service is always close at hand. If your sewing machine should need servicing, call your local Singer Sewing Center to be sure of warranted SINGER parts and service. You will find the address under SINGER COMPANY in the telephone directory.

## CONTENTS

	Page
<b>Getting to Know Your Sewing Machine</b> .....	2
Principal Parts.....	2
Accessories .....	6
<b>Getting Ready to Sew</b> .....	9
Preliminary Steps .....	9
Choosing Needle and Thread .....	10
Threading Your Sewing Machine.....	11
<b>Straight Stitching</b> .....	16
Adjusting Selectors for Your Fabric .....	17
Sewing a Seam .....	20
<b>Zig-Zag Stitching</b> .....	23
Basic Zig-Zag Patterns .....	23
Satin Stitching .....	26
<i>Flexi-Stitch</i> Patterns .....	27
<b>Twin-Needle Stitching</b> .....	30
Preparation .....	30
Threading for Twin-Needle Stitching .....	31
<b>Buttons and Buttonholes</b> .....	32
Buttons .....	32
Buttonholes .....	33
<b>Sewing the Professional Way</b> .....	36
Sewing Knit and Stretch Fabric .....	36
Hints on Sewing Special Fabrics .....	41
Construction Details .....	43
Decorative Touches .....	47
Keeping Up Appearances .....	49
<b>Caring for Your Machine</b> .....	53
Cleaning the Machine .....	53
Removing Cover, Bobbin Case, and Bulb.....	54
Performance Checklist .....	57
<i>Fashion*</i> Aids .....	58
<b>Index</b> .....	60

# GETTING TO KNOW YOUR

## *principal parts*

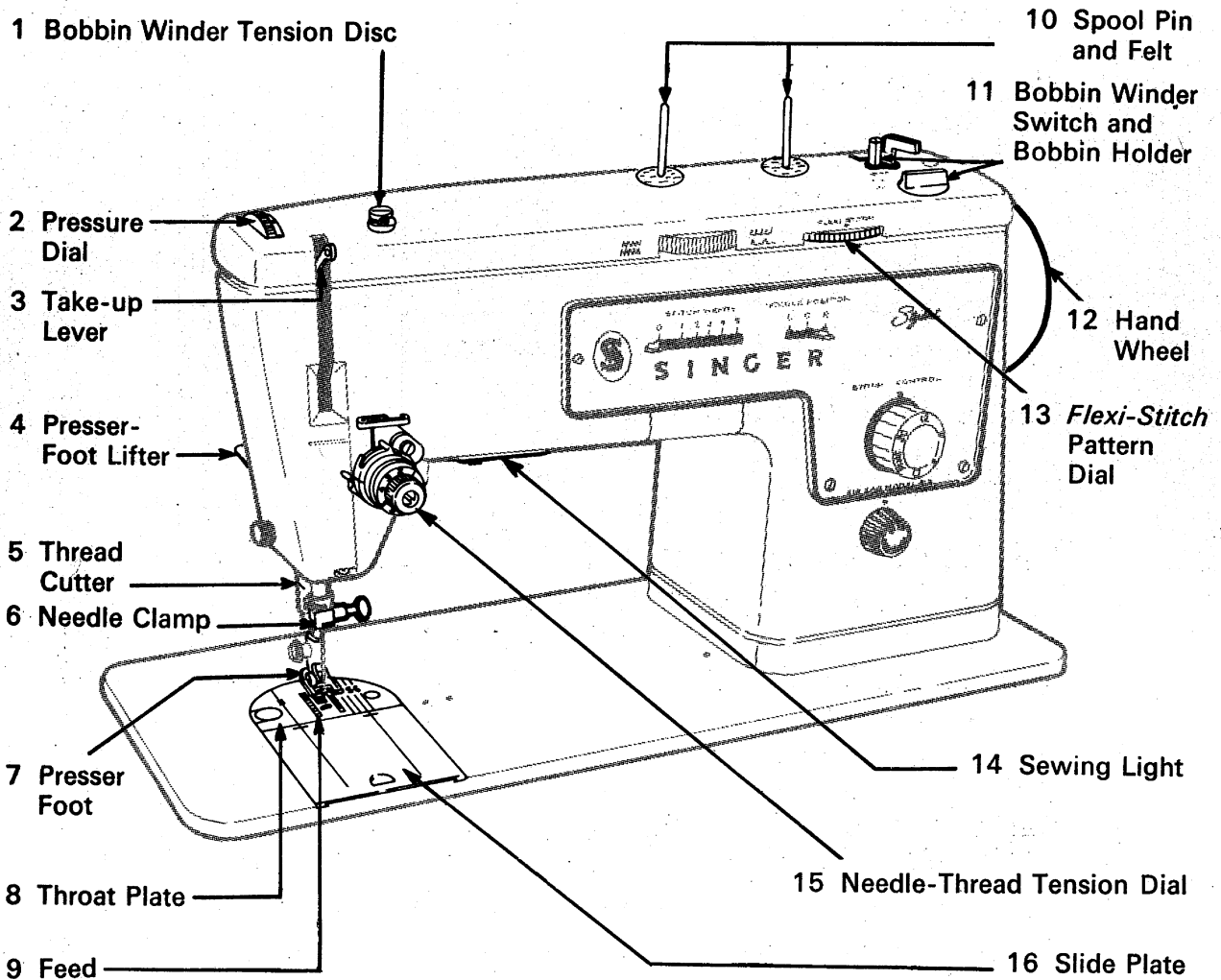





# **SINGER SEWING MACHINE**

## ***and what they do***

1. **Bobbin Winder Tension Disc** regulates thread tension for bobbin winding.
2. **Pressure Dial** regulates presser-foot pressure on fabric. Has eight numbered settings and a special setting for darning.
3. **Take-up Lever** controls flow of needle thread.
4. **Presser-Foot Lifter**, at back of machine, allows you to raise and lower presser foot. Extra-high lift position permits easy placement of bulky fabrics.
5. **Thread Cutter** is built into presser bar for safety and convenience.
6. **Needle Clamp** holds single or twin needles and is designed to eliminate the possibility of inserting needle backwards.
7. **Presser Foot** holds fabric against feed. The feet snap off for quick removal.
8. **Throat Plate** lifts out for easy removal. Guidelines on right *and* left sides extend to slide plate to help you keep seams straight.
9. **Feed** moves fabric under the presser foot.
10. **Spool Pin** holds thread spool. Felt helps thread unwind smoothly.
11. **Bobbin Winder Switch and Bobbin Holder** let you fill the bobbin with thread quickly and easily.
12. **Hand Wheel** positions take-up lever and needle. Always turn it toward you.
13. ***Flexi-Stitch* Pattern Dial** sets the machine for *Flexi-Stitch* pattern sewing and varies the balance of *Flexi-Stitch* patterns in order to correct pattern appearance. *Dial must be in off position O when not in use.*
14. **Sewing Light** illuminates the sewing area.
15. **Needle-Thread Tension Dial** lets you select just the right tension for your stitch, thread and fabric.
16. **Slide Plate** opens for easy removal and replacement of the bobbin and raises and lowers the pin that holds the throat plate in place.

PRINCIPAL PARTS (Continued)

17. **Pattern Selector** lets you select plain zig-zag (  ) or blindstitch (  ) zig-zag patterns; also ric-rac (  ) or slant overedge (  ) *Flexi-Stitch* patterns.
18. **Needle Position Selector** places needle in either left, center or right stitching position. Use center position for straight stitching.
19. **Stitch Width Selector** controls the width of zig-zag stitching and positions the needle for straight stitching.
20. **Stitch Control Dial** allows for a variety of stitch lengths, including FINE for zig-zag satin stitching. Has special setting for *Flexi-Stitch* pattern sewing.
21. **Power and Light Switch** turns on the power and the sewing light simultaneously.

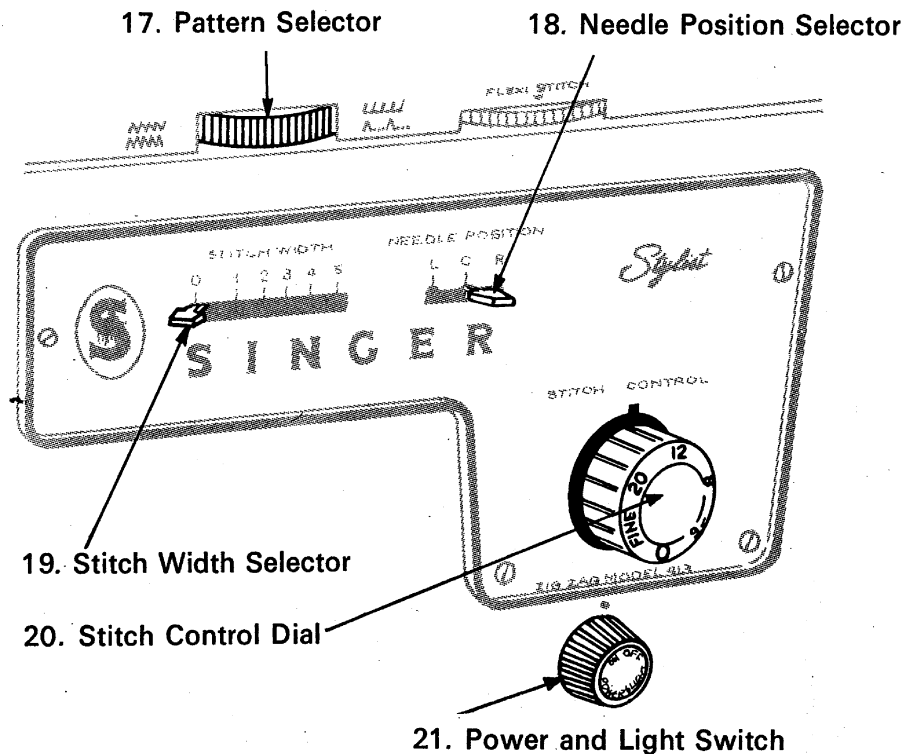

22. **Hand Wheel Knob** engages hand wheel to sewing mechanism. Loosen knob for bobbin winding.

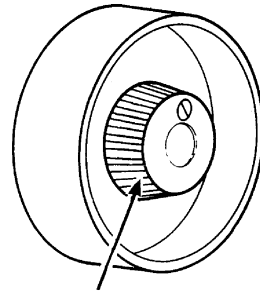

22 Hand Wheel Knob

23. **Transparent Bobbin** shows thread supply. Easily removed for winding.

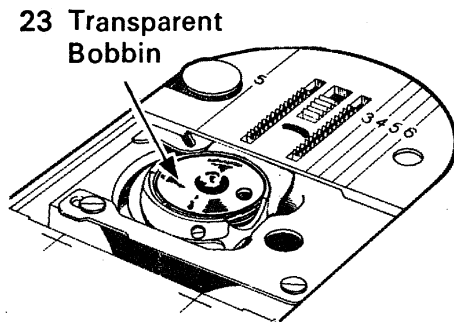

23 Transparent Bobbin

24. **Electrical Connections and Speed Controller** are designed for convenience and safety.

- **To run the machine and control speed**, press the speed controller. The harder you press, the faster the machine will sew.
- **To stop the machine**, remove pressure from the speed controller.

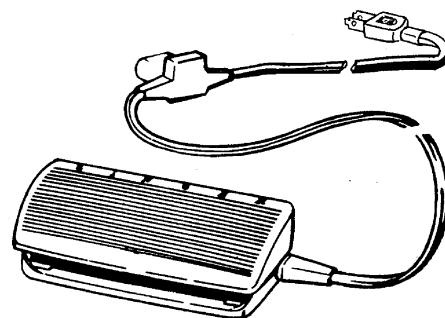

24 Electrical Connections and Speed Controller

*See instructions for connecting machine and operating machine and controller on page 9.*

## *accessories... and when to use them*

The accessories that come with your *Stylist* sewing machine will help you to sew with ease and comfort. They are simple to use and place a variety of sewing effects at your fingertips. Additional accessories, listed on page 58, are available for purchase at your Singer Sewing Center.

**General Purpose Foot**

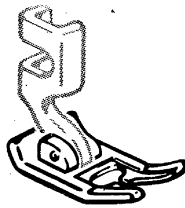

### **GENERAL PURPOSE FOOT AND THROAT PLATE**

The general purpose foot and the general purpose throat plate are in place on the machine. Use them for all utility sewing, with either straight or zig-zag stitching.

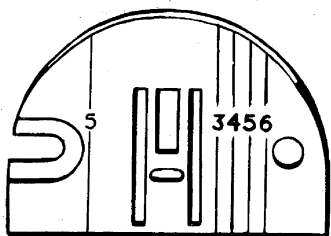

**General Purpose Throat Plate**

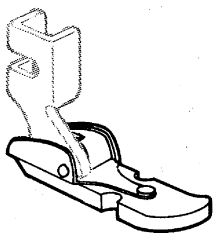

**Zipper Foot**

### **ZIPPER FOOT**

The zipper foot is used to place stitching close to a raised edge. It can be fitted to the presser-foot shank for use on either right or left side of the needle. Use it for:

- Corded seams
- Tubular cording
- Zipper insertion

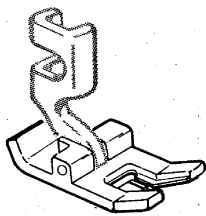

**Special Purpose Foot**

### **SPECIAL PURPOSE FOOT**

The special purpose foot is used for all kinds of decorative zig-zag stitching. Use this foot for:

- Zig-zag satin stitching
- Ornamental stitching with *Flexi-Stitch* patterns
- Applique
- Buttonholes
- Twin-needle stitching



## FEED-COVER THROAT PLATE

The feed-cover throat plate is used in place of the general purpose throat plate when fabric feeding is not desired. Use it for button sewing (page 32) and free-motion darning (page 52).

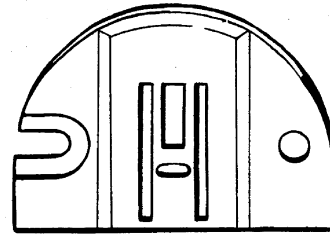

Feed Cover Throat Plate

## CHANGING THROAT PLATE

- Raise presser foot. (You do not need to remove the foot.)
- Turn hand wheel toward you until needle is in its highest position.
- Open slide plate with downward finger pressure. Draw plate toward you, opening it *all the way* to raise the throat plate locking pin and unlock the throat plate.
- Place thumb under throat plate and draw plate to the right to remove.
- Insert new throat plate under locking pin and over positioning pin.
- Close slide plate to lower locking pin and secure the throat plate.

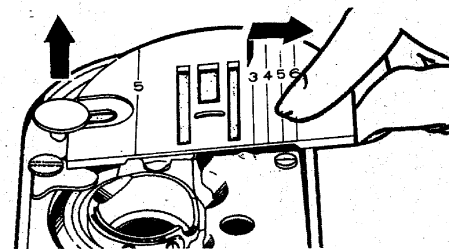
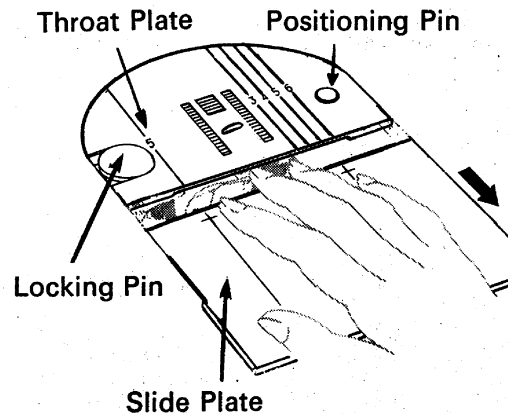

Changing Throat Plate

## CHANGING PRESSER FEET

The presser feet that are supplied with your machine snap on and off a common shank. To change the foot:

- Raise needle to its highest position and raise the presser foot lifter.
- Press toe of presser foot upward (as far as it will go) and then snap down to remove the foot.
- Center the new presser foot under the shank and lower the presser foot lifter so that shank fits over the presser foot pin.
- Press down on presser-foot screw until foot snaps into place.

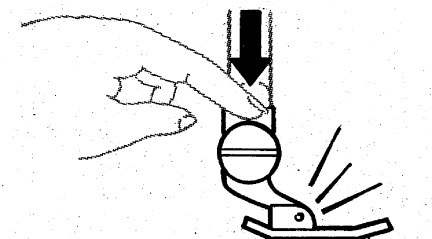
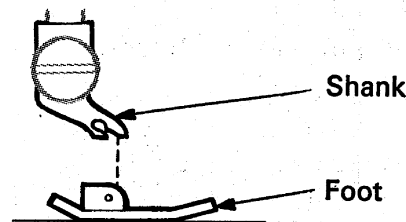

Changing Presser Foot

## ACCESSORIES (Continued)

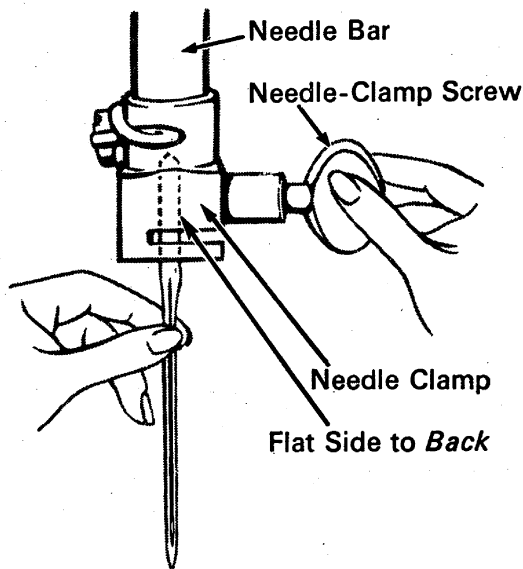
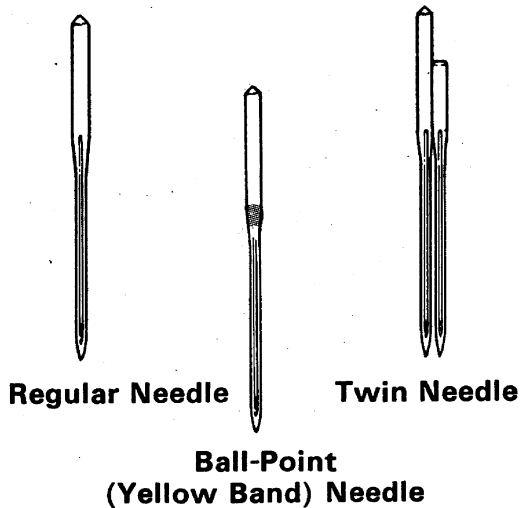

Changing the Needle

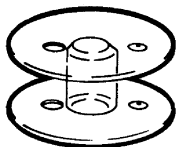

Transparent Bobbin



Tension Screwdriver

## NEEDLES

- Style # 2020 needles for all-purpose sewing.
- Style # 2045, ball-point (yellow band) needles, for sewing synthetic knits and stretch fabrics.
- Style # 2028, twin needle, for decorative twin-needle stitching.

## CHANGING THE NEEDLE

The needle clamp is designed so that the needle can only be inserted with the flat side of the needle to the back. To change the needle:

1. Raise needle bar to its highest position, loosen needle clamp screw, and remove needle.
2. Insert new needle in clamp, with the flat side of the needle to the back; push it up as far as it will go.
3. Tighten needle clamp screw.

## BOBBINS

Transparent, drop-in bobbin, # 172336, shows thread supply at a glance.

## TENSION SCREWDRIVER

Designed to fit the bobbin case screw, this screwdriver makes adjustment of bobbin-thread tension quick and easy. See page 19 for instructions.

# GETTING READY TO SEW

## *preliminary steps*

### CONNECTING MACHINE

Before plugging in your machine, be sure that the voltage and number of cycles indicated on the plate under the hand wheel conform to your electrical power supply.

Push the machine plug into the receptacle at the right end of the machine. Then connect the power-line plug to your electrical outlet.

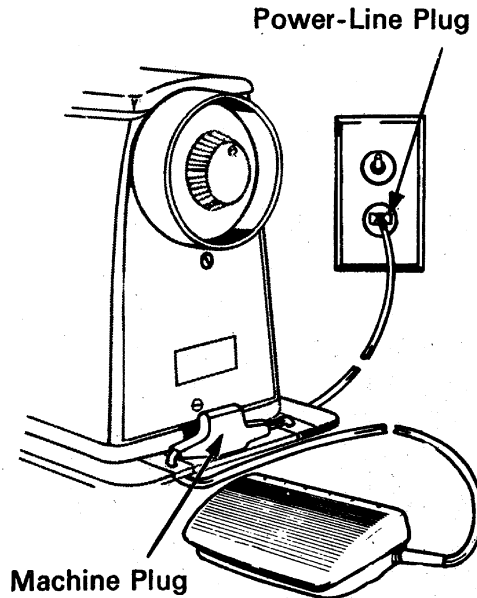

### OPERATING MACHINE AND CONTROLLER

To turn on both machine and sewing light, turn power and light switch to the right to ON position. To turn off machine and light, turn switch to left to OFF position.

**CAUTION:** *We recommend that you turn off the power and light switch before changing needles, presser feet and throat plates and when leaving the machine unattended. This eliminates the possibility of starting the machine by accidentally pushing the speed controller.*

To run the machine, press the speed controller. The harder you press, the faster the machine will sew.

To stop the machine from sewing, remove pressure from speed controller.

Electrical Connections



Power and Light Switch

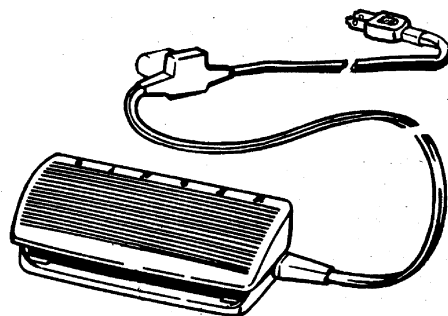

Speed Controller

*choosing needle and thread*

The needle and thread you choose will depend upon the fabric being stitched. The table below is a practical guide to needle and thread selection. Refer to it before starting a sewing project. Be sure to use the same size and type of thread in both needle and bobbin.

**FABRIC, THREAD AND NEEDLE TABLE**

Fabric	Thread	Needles	
		Type	Size
<b>DELICATE</b> — tulle, chiffon, fine lace, organza	Fine mercerized cotton Fine synthetic thread	STYLE 2020 (15 × 1)	9
<b>LIGHTWEIGHT</b> — batiste, organdy, jersey, voile, taffeta, crepe, chiffon	50 mercerized cotton "A" silk Synthetic thread Polyester core/cotton	STYLE 2020 (15 × 1)	11
<b>MEDIUM WEIGHT</b> — gingham, percale, pique, linen, chintz, faille, satin, fine corduroy, velvet, suitings, knits, deep-pile fabrics, vinyl	50 mercerized cotton 60 cotton "A" silk Synthetic thread Polyester core/cotton	STYLE 2020 (15 × 1)	14
<b>MEDIUM HEAVY</b> — gabardine, tweed, sailcloth, denim, coatings, drapery fabrics, vinyl, deep-pile fabrics	Heavy-duty mercerized cotton 40 to 60 cotton Synthetic thread	STYLE 2020 (15 × 1)	16
<b>HEAVY</b> — overcoatings, dungaree, upholstery fabrics, canvas	Heavy-duty mercerized cotton 24 to 40 cotton Synthetic thread	STYLE 2020 (15 × 1)	18
<b>ALL WEIGHTS</b> — decorative topstitching	"D" silk † (Buttonhole twist)	STYLE 2020 (15 × 1)	16 or 18
<b>SYNTHETIC KNITS and STRETCH FABRICS</b> — polyester doubleknit, spandex, nylon tricot, ciré tricot, jersey, panné velvet	"A" nylon 50 mercerized cotton "A" silk Polyester core/cotton	STYLE 2045 Ball Point (Yellow Band)	14
<b>LEATHER</b> — suede, kidskin, capeskin, lambskin, lined leathers	50 mercerized cotton Synthetic thread "A" silk Polyester core/cotton	STYLE 2032 (15 × 2)	11 14 16
<b>LIGHT and MEDIUM WEIGHTS</b> — decorative twin-needle stitching	50 mercerized cotton	STYLE 2028 (twin)	14

†Use with 50 mercerized cotton or "A" silk in bobbin.

## *threading your sewing machine*

Like all sewing machines that produce what is called a "lockstitch", your *Stylist* sewing machine sews with two threads. The upper thread comes from the spool and is threaded through the eye of the needle. The lower thread comes from the bobbin, the small transparent spool that you wind using the machine. It is best to wind the bobbin before threading the needle.

### **THE BOBBIN THREAD**

#### **Winding the Bobbin**

- Raise the presser foot and turn the hand wheel toward you until needle is at its highest position.
- Loosen the hand wheel knob by turning it toward you with the right hand while holding the hand wheel with the left hand.
- Open slide plate. Draw plate toward you, opening it just enough to make bobbin accessible (opening it all the way raises the pin that holds the throat plate in place).
- Lift out bobbin and close slide plate to make sure throat plate is secure while winding.

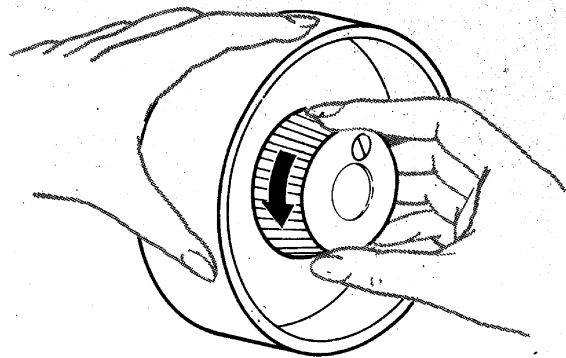

**Loosening Hand Wheel Knob**

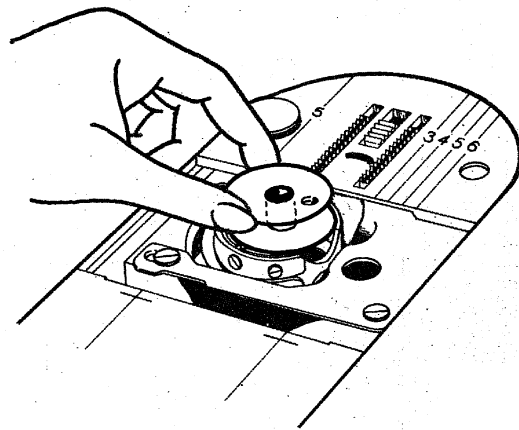

**Removing Bobbin**

## THE BOBBIN THREAD (Continued)

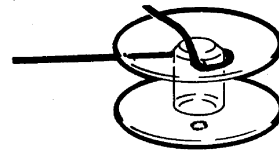
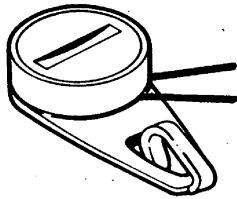

Pass Thread Through  
Hole in Bobbin

Bobbin Winder Tension Disc

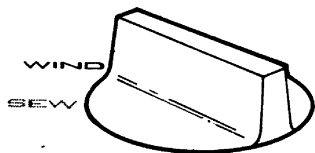
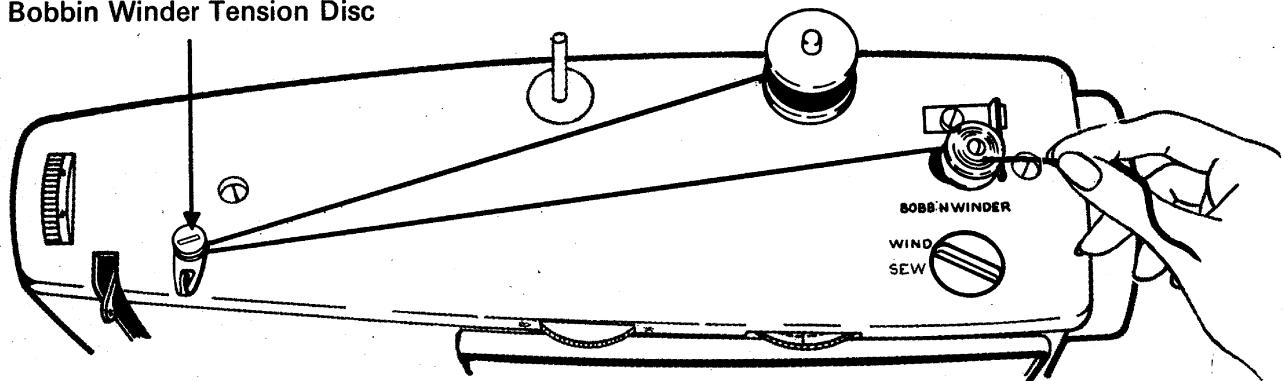

Bobbin Winder Switch

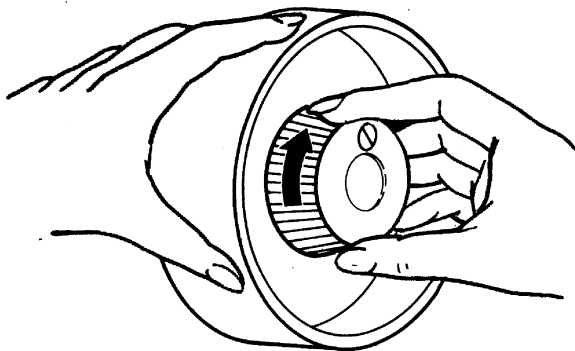

Tightening Hand Wheel Knob

- Place thread spool on spool pin over felt. Lead thread around bobbin winder tension disc and through small hole in bobbin (from the inside).
- Place bobbin on holder and turn bobbin winder switch to WIND.
- Hold thread as shown and start the machine. Cut off thread end when winding is well under way.
- When required amount of thread has been wound (winding will stop by itself when bobbin is full), stop the machine and cut connecting thread.
- Turn bobbin winder switch to SEW and remove bobbin from holder.
- Tighten hand wheel knob.

## THREADING THE BOBBIN CASE

1. Hold bobbin so that thread unwinds in direction shown, and put bobbin in bobbin case.

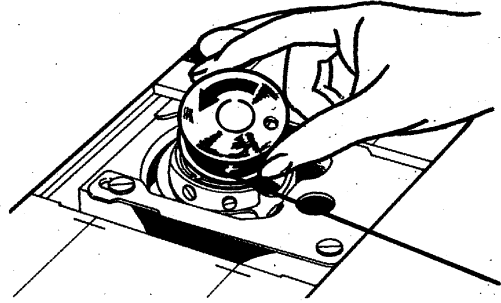

2. Pull thread into notch, draw it under tension spring and back into slot.

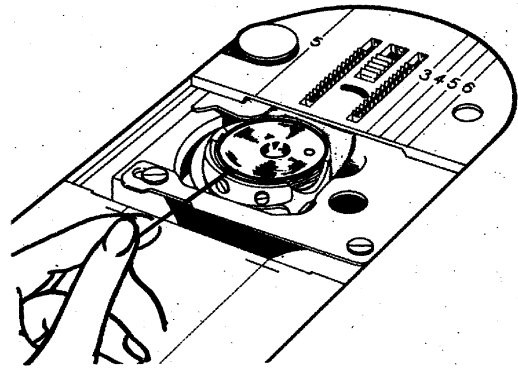

3. Draw about three inches of thread diagonally across the bobbin.

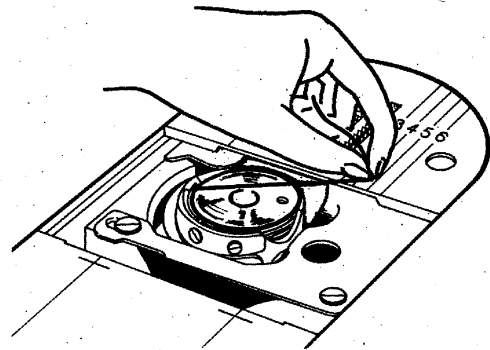

4. Close slide plate allowing thread to enter slot between the throat plate and slide plate.

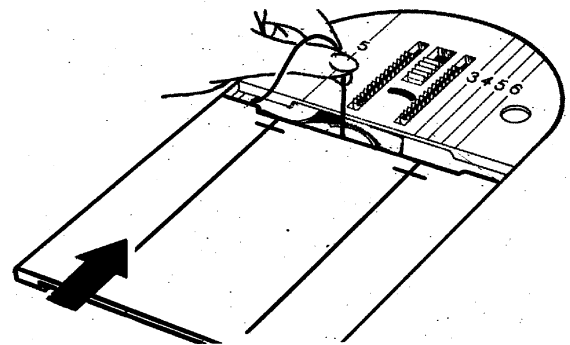

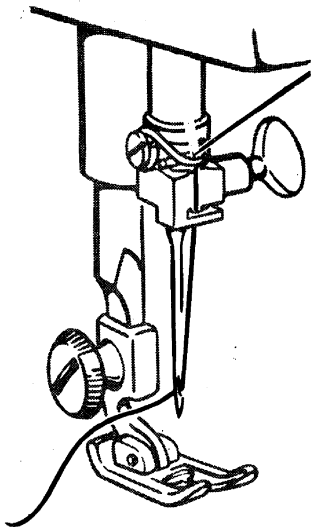
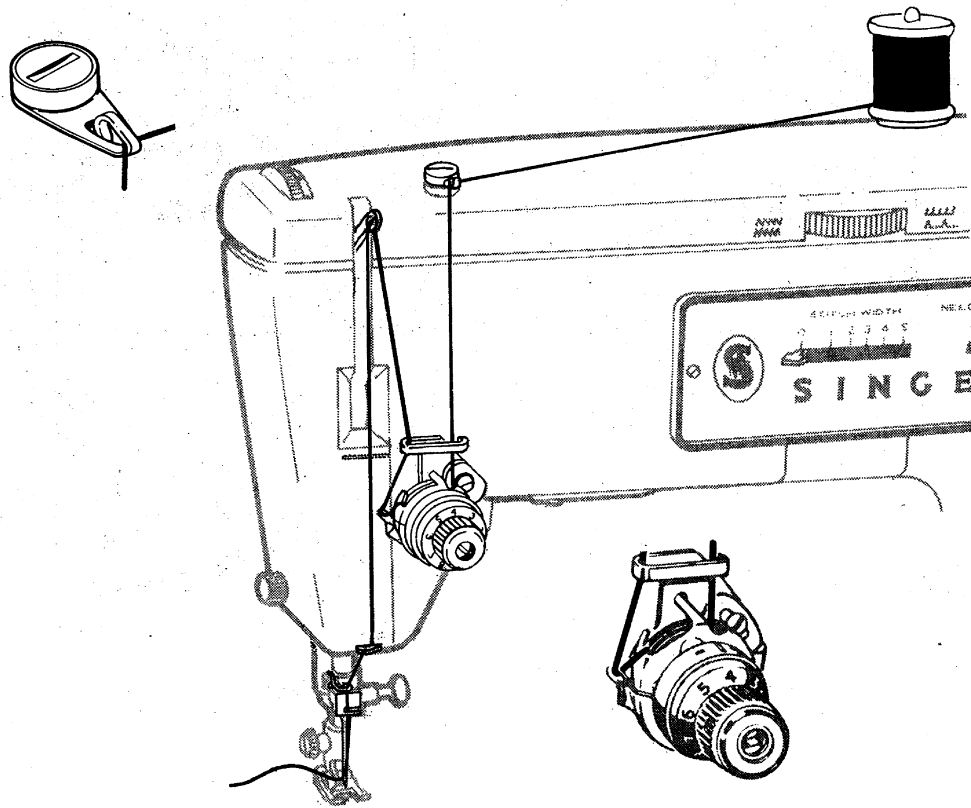

## THE NEEDLE THREAD

1. Turn hand wheel toward you to raise needle to its highest position and raise presser foot.
2. Place spool of thread on spool pin over felt and lead thread through all threading points shown. Thread the needle from front to back.
3. Draw about three inches of thread through eye of needle.



## RAISING THE BOBBIN THREAD

Now that you have wound the bobbin and threaded the needle, you will need to raise the bobbin thread through the needle hole in the throat plate.

1. Hold needle thread lightly with left hand and turn hand wheel slowly toward you so that needle enters hole in throat plate.

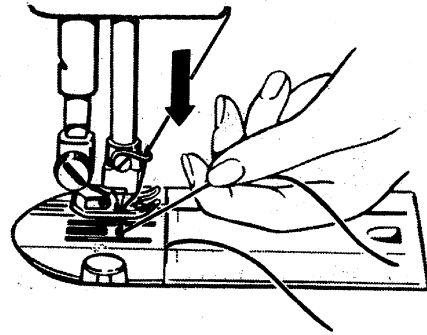

2. Continue turning hand wheel and holding needle thread until needle rises and brings up bobbin thread in a loop.

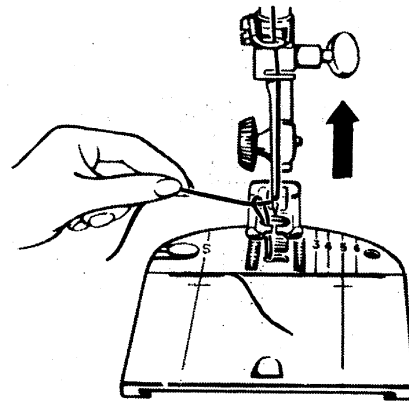

3. Undo the loop with your fingers.

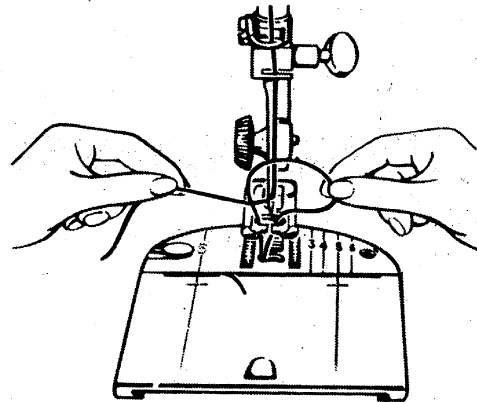

4. Place both needle and bobbin threads under presser foot, and draw to back of machine.

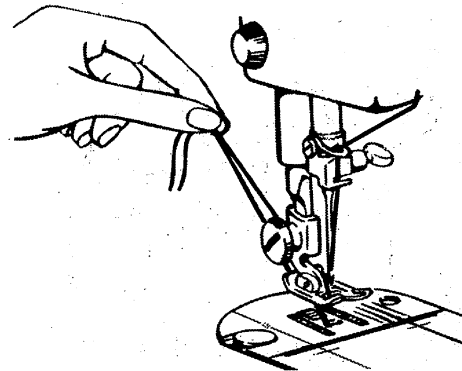

. . . You are now ready to sew

## STRAIGHT STITCHING

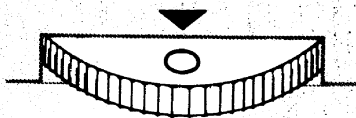

**Flexi-Stitch Pattern Dial Off**

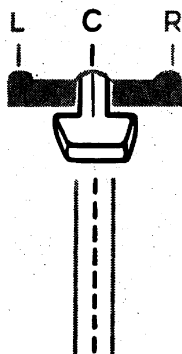

**Needle Position**

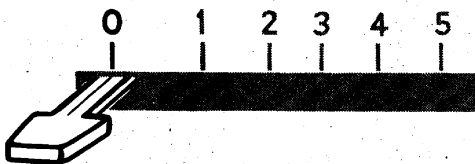

**Stitch Width**

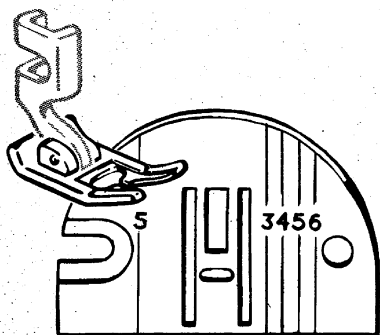

**Accessories**

- *Flexi-Stitch* Pattern Dial : **O** (off)
- Pattern Selector : Any setting
- Needle Position : **C**
- Stitch Width : **O**
- Stitch Length : To suit fabric
- General Purpose Throat Plate
- General Purpose Foot

Before you move the selectors to set your sewing machine for straight stitching, turn the hand wheel toward you until the needle is above the throat plate.

### SETTING THE MACHINE

- Turn *Flexi-Stitch* pattern dial to off position **O**.
- Move needle position selector to center **C**.
- Set stitch width selector on **O**.

### STARTING TO SEW

- Place needle and bobbin threads under presser foot and draw to back of machine.
- Position the needle in the fabric where desired for stitching start.
- Lower the presser foot and start the machine.

To sew perfectly on a wide variety of fabrics, adjust stitch length, pressure and thread tension as instructed on the following pages.

*For information on straight stretch stitching turn to page 27.*

## *adjusting selectors for your fabric*

### **ADJUSTING STITCH LENGTH**

The stitch control dial regulates the length of stitches. The numbers on the dial express stitch length in stitches per inch; the higher the number, the shorter the stitch. Generally, shorter stitches are best for lightweight fabric; longer ones for heavy fabric. The FINE area is used for the adjustment of zig-zag satin stitching.

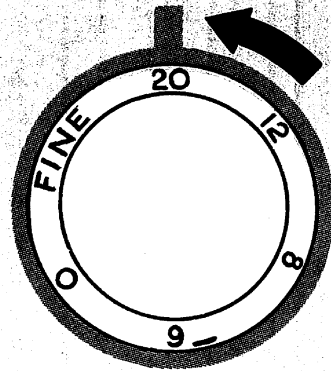

**Stitch Control Dial**

### **Setting the Selector**

- Turn dial so that the stitch length desired is positioned under the pointer symbol  on the control panel.
- To *shorten* the stitch length, turn the dial clockwise to a higher number.
- To *lengthen* the stitch, turn the dial counterclockwise to a lower number.

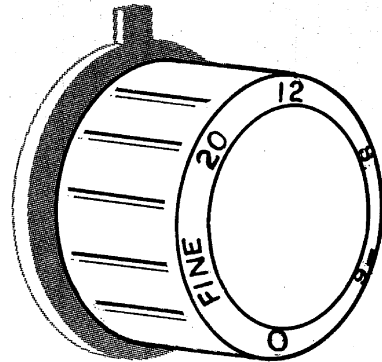

**For reverse stitching,** press the stitch control dial in as far as it will go and hold in place (the dial can be pushed in while the machine is sewing). Release pressure on the dial to return to forward stitching.

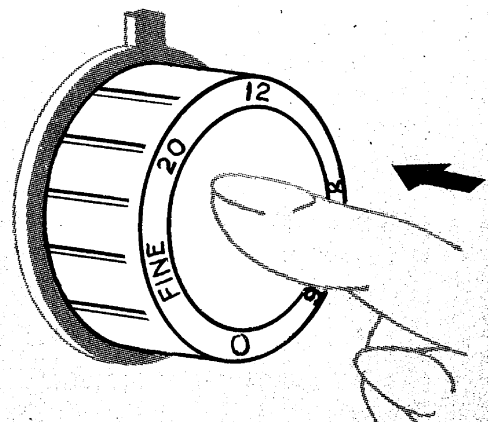

**Reverse Stitching**

*(For detailed instructions on adjusting the stitch length for zig-zag satin stitching, see page 26.)*

## ADJUSTING PRESSURE

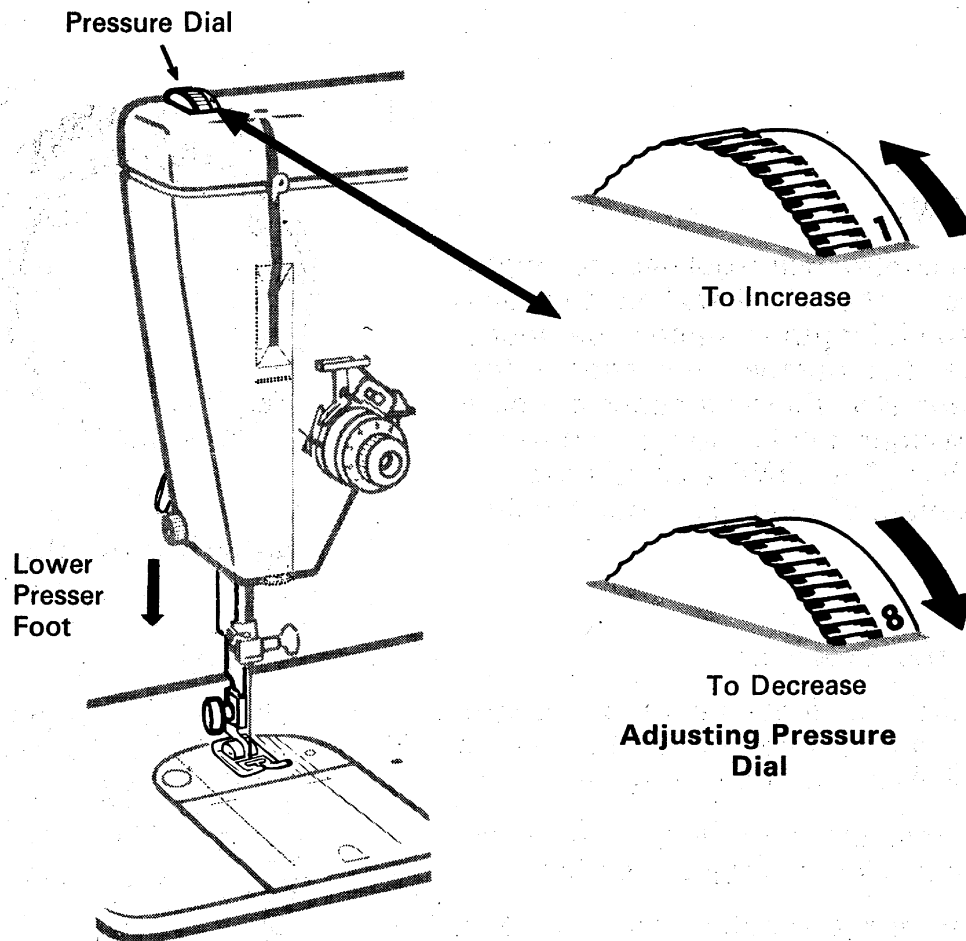

The pressure dial regulates the pressure that the presser foot exerts on the fabric. Correct pressure is important because it enables the fabric to feed smoothly and evenly, without being marred. The numbered settings on the pressure dial will assist you in obtaining the correct pressure for the fabric you are using. Generally, heavier fabrics and fabrics of knit and stretch construction require a high number setting (heavier pressure); lightweight fabrics, a lower setting (lighter pressure). But fabric texture must also be considered. Soft fabrics, for example, require less pressure than crisp fabrics.

When darning without an embroidery hoop, you should set the dial at the lowest setting, D. See page 51 for instructions.

*Lower the presser foot before setting pressure.*

- To *increase* pressure, turn dial to higher number.
- To *decrease* pressure, turn dial to lower number.
- For darning, set dial on D.

## REGULATING THREAD TENSION

Correct tension is important because too much or too little will weaken your seams or cause your fabric to pucker. Make a test sample with the fabric and thread you plan to use and examine it. A perfect stitch will have the needle and bobbin threads locked between the two layers of fabric with no loops on top or bottom and no puckers.

### Needle-Thread Tension

The tension dial regulates the degree of tension on your needle thread. Set it according to the type of thread and fabric you use. The numbers on the dial eliminate guesswork in duplicating settings.

If the stitches in your test sample look loose, increase needle-thread tension. If the fabric puckers, decrease tension.

- To **increase** tension, turn dial to higher number.
- To **decrease** tension, turn dial to lower number.

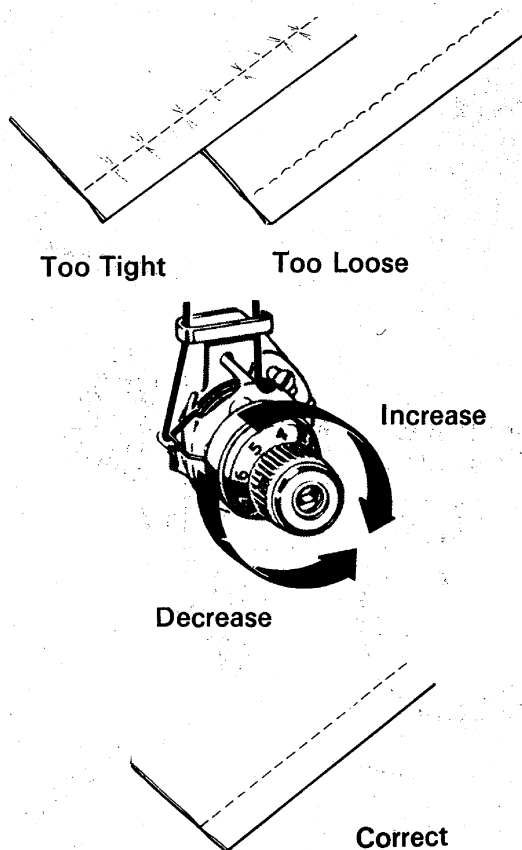

## *sewing a seam*

### **PIN BASTING**

Pin basting is a time-saver and can be used when you sew easy-to-handle fabric. Use fine pins and place them:

- On top of the fabric (never on the underside in contact with the feed).
- At right angles to the stitching line.
- Just nipping into the fabric at the stitching line (never extending under both sides of the presser foot).

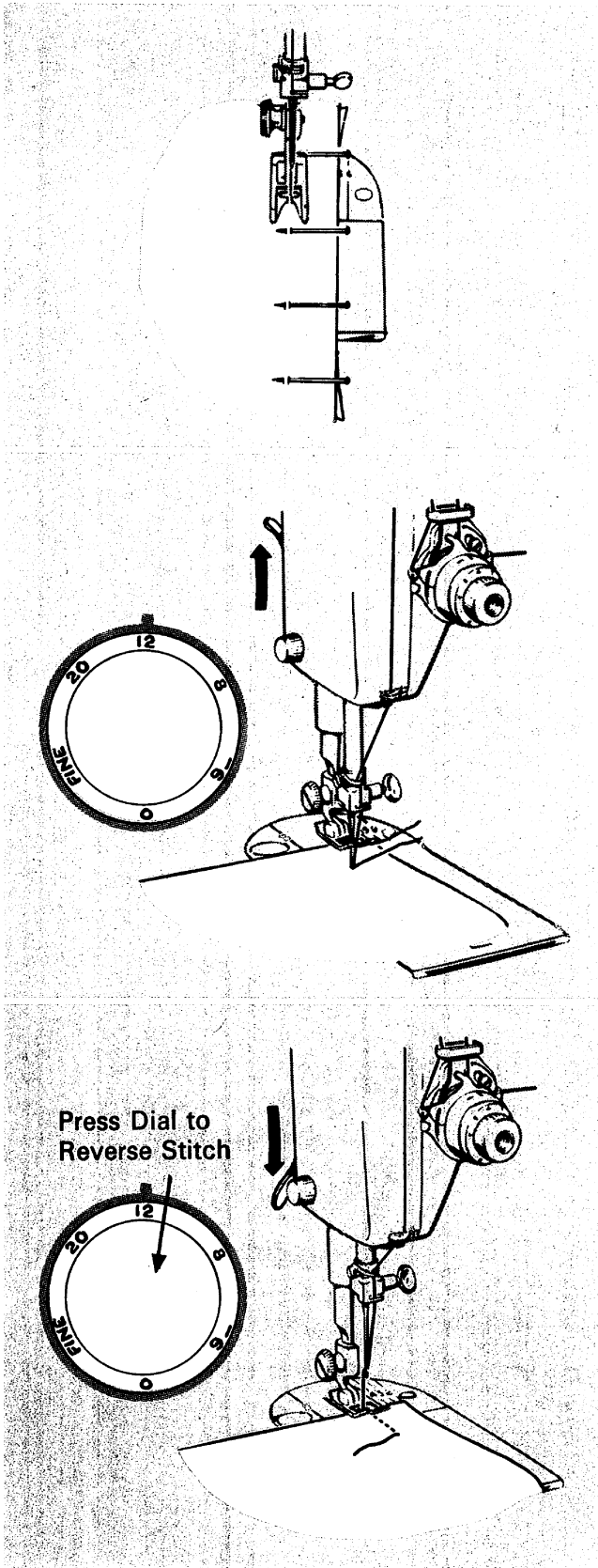

### **STARTING A SEAM**

1. Set stitch length selector for desired number of stitches per inch.
2. With presser foot up, align fabric with appropriate seam guideline on throat plate (as described on the following page). Position needle in fabric about  $\frac{1}{2}$  inch from the back edge.
3. Lower presser foot. Backstitch to the edge of the fabric for reinforcement by pushing in the stitch control dial. Hold the dial in until the stitches reach the edge of the fabric and then release for forward stitching.

## KEEPING THE SEAM STRAIGHT

As you stitch, use one of the numbered lines on the throat plate as a guide for keeping the seams straight. Numbers indicate distance, in eighths of an inch, from the needle. If you want a  $\frac{5}{8}$ -inch seam, for example, keep the right-hand edge of your fabric on the number 5 guideline.

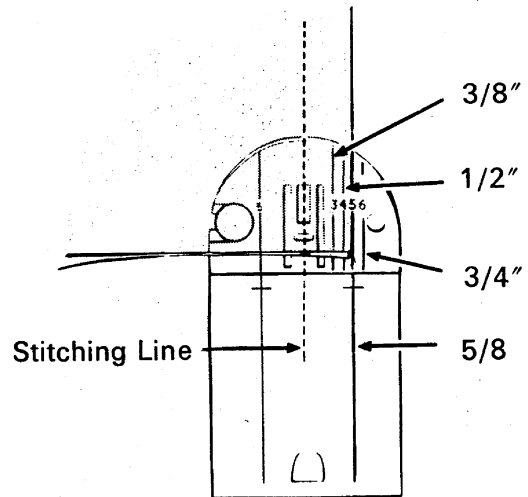

Using Guidelines

## TURNING SQUARE CORNERS

To turn a square corner  $\frac{5}{8}$ -inch from the fabric edge, you need not measure or mark the seam. Simply use the crosslines on the slide plate.

- Line up your fabric with right or left guideline 5 on the throat plate. Stitch seam, slowing speed as you approach corner.
- Stop stitching, *with the needle down*, when the bottom edge of the fabric reaches the cornering crosslines on the slide plate.
- Raise presser foot and turn fabric on needle, bringing bottom edge of fabric in line with guideline 5.
- Lower the presser foot and stitch in new direction.

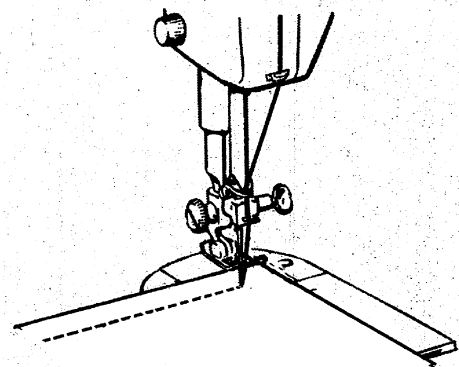
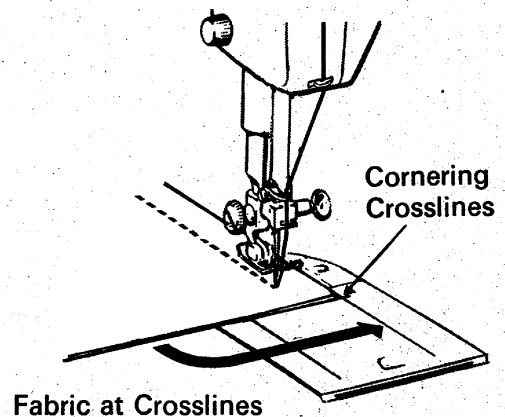

Fabric after Turning

Pivoting at Corner

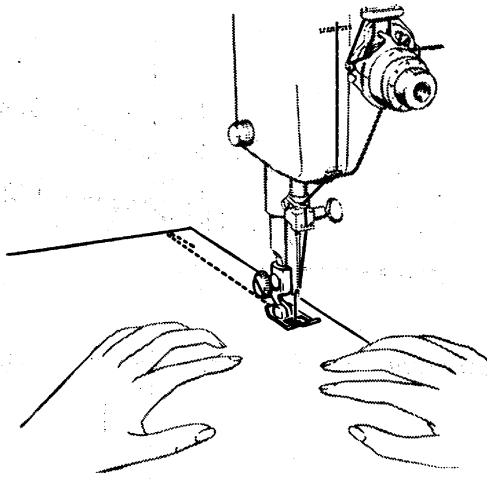

Guiding Fabric

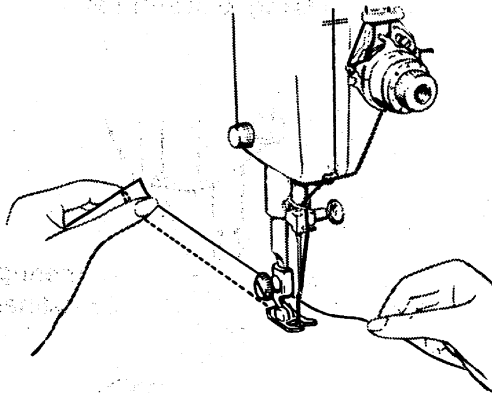

Supporting Fabric

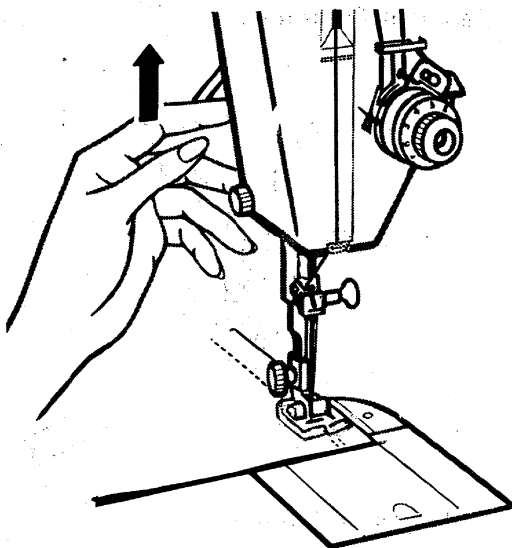

Ending a Seam

## GUIDING AND SUPPORTING THE FABRIC

Most fabrics need only to be *guided* in front of the presser foot. Some fabrics, however, require *support* while being stitched. Filmy sheers, panned velvet, and tricot, for example, need to be held taut in front and back of the presser foot while being sewn.

For information on sewing knit and stretch fabrics with zig-zag stitching, refer to page 37.

## REINFORCING END OF SEAM

1. Stitch to the fabric edge.
2. Push in stitch control dial and back-stitch  $\frac{1}{2}$  inch to reinforce the end of the seam.
3. Raise presser foot and remove fabric by drawing it to the back and left.
4. Cut threads on thread cutter at rear of presser bar.

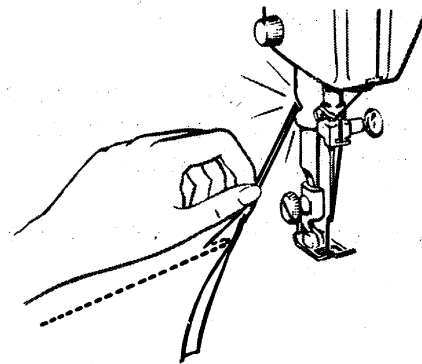



# ZIG-ZAG STITCHING

The zig-zag stitches built into your sewing machine include basic zig-zag patterns and *Flexi-Stitch* patterns. Basic zig-zag patterns and their selector settings are shown below; information on *Flexi-Stitch* patterns starts on page 27. You will find instructions for both decorative and practical uses of these patterns in the section called "Sewing the Professional Way" beginning on page 36.

## BASIC ZIG-ZAG PATTERNS



**Plain Zig-Zag Stitch.** Used for buttonholes, button sewing, bar tacks and applique.



**Blindstitch.** Indispensable for finishing hems and seam edges and for zipper insertion.

## TO SEW A ZIG-ZAG STITCH PATTERN USE BLACK SELECTOR SETTINGS

- Turn *Flexi-Stitch* pattern dial to black off setting 0.
- Set pattern selector for stitch desired.
- Adjust stitch length, stitch placement, stitch width and needle-thread tension as instructed on the following pages.

## SETTING PATTERN SELECTOR

*Set the stitch width on 0 before moving pattern selector dial.*

The pattern selector, located above the stitch width selector on the front of the machine, controls stitch selection.

### For Plain Zig-Zag Stitching

- Move selector dial toward 

### For Blindstitching

- Move selector dial toward 

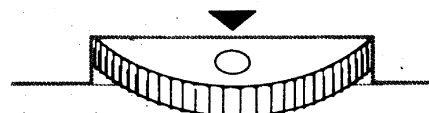

*Flexi-Stitch* Pattern Dial Off

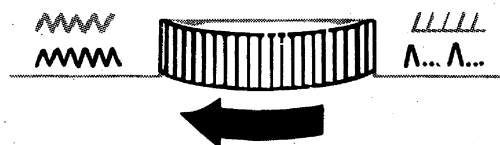

For Zig-Zag Stitching

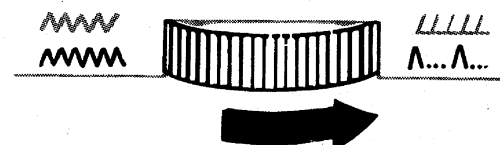

For Blindstitching

Pattern Selector

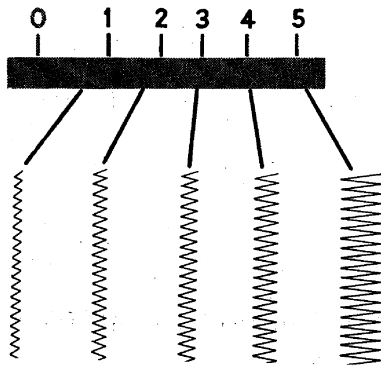

**Adjusting Stitch Width**

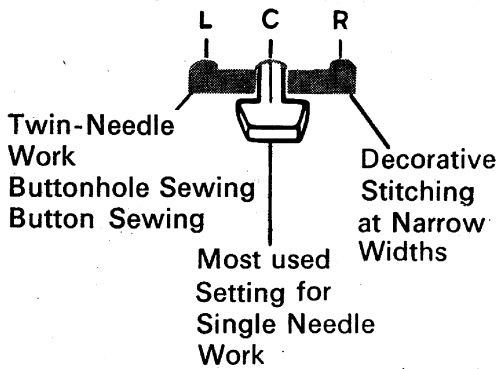

**Adjusting Stitch Placement**

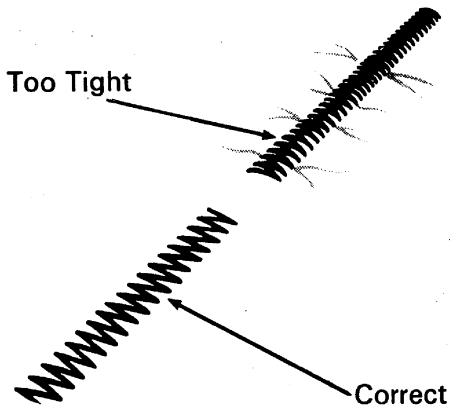
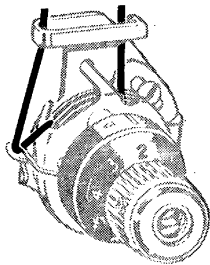

**Adjusting Needle-Thread Tension**

*Before moving stitch width and needle position selectors make sure needle is above fabric.*

## ADJUSTING WIDTH OF DESIGN

To produce a zig-zag stitch pattern, move the stitch width selector from straight stitch setting 0, to any setting between 1 and 5. The higher the number, the wider the stitch.

## ADJUSTING STITCH PLACEMENT

Most of your basic zig-zag stitching will be done in center (C) needle position. Left (L) and right (R) settings are used for special stitch placement, as in buttonhole sewing, button sewing and twin-needle work.

## ADJUSTING NEEDLE-THREAD TENSION

Zig-zag stitching requires less needle-thread tension than straight stitching. Make a test sample with the fabric and thread you plan to use so that you can adjust the tension properly. The stitches should lie flat against the fabric without causing the fabric to pucker.

If the stitches are not flat and the fabric is puckered, reduce needle-thread tension by turning the dial to a lower number.

## ADJUSTING STITCH LENGTH

Any stitch length setting from 6 to 20 will give you an open zig-zag stitch of the basic zig-zag stitch pattern you select. The lower the number, the more open, or farther apart, your stitches will be. The **FINE** stitch area, between 0 and 20 on the dial, is used for adjusting zig-zag satin stitching (see next page for specific instructions).

When using the plain zig-zag or blind-stitch patterns, be sure the *Flexi-Stitch* pattern dial is in off position 0.

## STITCH CONTROL

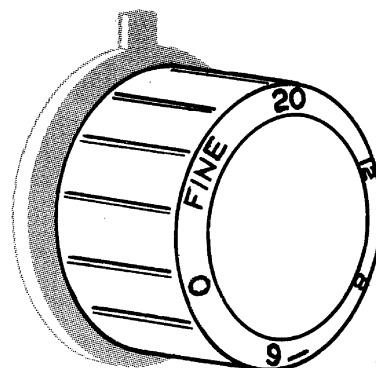

## ADJUSTING PRESSURE AND CHOOSING ACCESSORIES

Turn to page 18 under straight stitching for instructions on adjusting pressure.

For information on choosing accessories, refer to pages 6 and 7 and to detailed instructions for sewing with zig-zag stitch patterns included in the section called "Sewing the Professional Way" that starts on page 36.

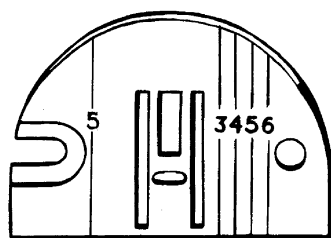

**General Purpose  
Throat Plate**

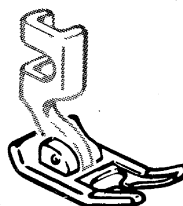

**General Purpose  
Foot**

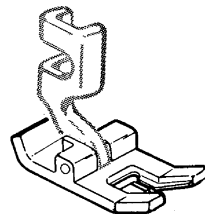

**Special Purpose  
Foot**

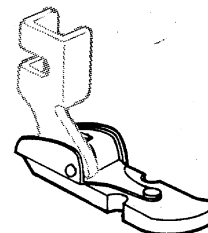

**Zipper Foot**

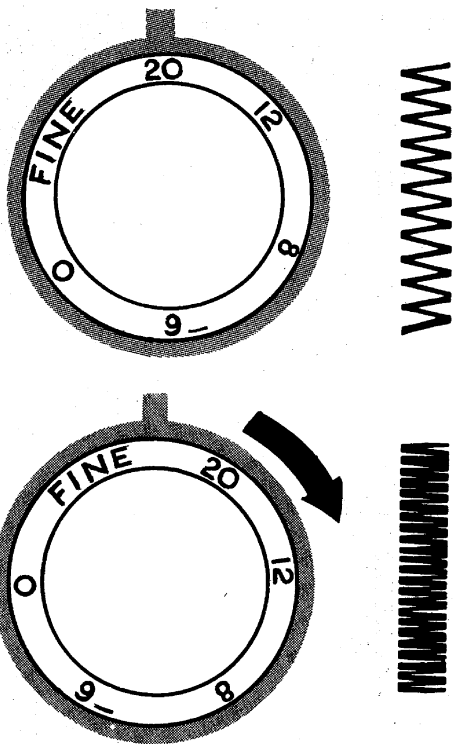

Adjusting Stitch Length

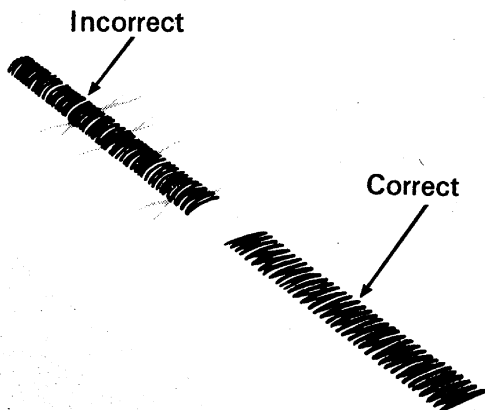
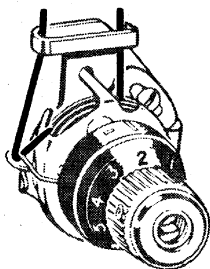

Adjusting Thread Tension

## *satin stitching*

Satin stitching—a series of closely spaced zig-zag stitches that form a smooth, satin-like surface—is useful for both practical and decorative work.

When you wish to produce a satin stitch for applique or bar tacks, for example, make a test sample first so that you can adjust the stitch length and thread tension properly. Soft fabrics may require a backing to ensure firm satin stitching. Crisp lawn or organdy is suitable for this purpose.

### ACCESSORIES AND SELECTOR SETTINGS

- *Flexi-Stitch* Pattern Dial : 0
- Pattern Selector : MM (plain zig-zag)
- Needle Position : C
- Stitch Width : 1-5
- Stitch Length : FINE (20 or above)
- General Purpose Throat Plate
- Special Purpose Foot
- Pressure : 2 or 3

### Adjusting Stitch Length

1. Turn stitch length selector dial to 20 (the beginning of FINE area).
2. Run the machine at a slow speed.
3. Gradually turn the stitch length dial clockwise until stitches are closely spaced and form a smooth surface.

### Adjusting Thread Tension

Satin stitching requires less tension than straight stitching or open zig-zag stitching. Furthermore, the wider the stitch, the lighter the tension on the thread must be. Notice the stitching on your sample. If the fabric is puckered, lower the needle-thread tension by turning the tension dial to a lower number.

## FLEXI-STITCH patterns

With your Stylist sewing machine you can sew three *Flexi-Stitch* patterns.

Instructions for both decorative and practical uses of these patterns begin on page 36.

### FLEXI-STITCH PATTERNS



**Ric-Rac Stitch.** An open, reinforced zig-zag stitch for heavy-duty stretch sewing and decorative work.



**Slant Overedge Stitch.** Lets you seam and overedge in one operation.



**Straight Stretch Stitch.** A triple straight stitch, indispensable for seaming knit, stretch, and elasticized fabric.

#### To Sew a *Flexi-Stitch* Pattern Use Red Selector Settings

- Set *Flexi-Stitch* dial on red **I**.
- Set pattern selector for desired stitch.
- Set stitch control dial on red **—**.
- Adjust stitch placement, stitch width, thread tension, and stitch balance as instructed on the following pages.

#### Setting Stitch Pattern Selector

Set the stitch width selector on **0** before moving the pattern selector dial.

##### For Ric-Rac Stitch

- Move pattern selector to 

##### For Slant Overedge Stitch

- Move pattern selector to 

##### For Straight Stretch Stitch

- Any pattern selector setting at stitch width **0**.

#### FLEXI-STITCH

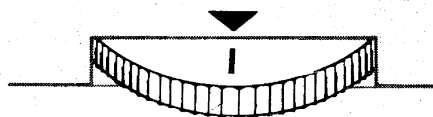

*Flexi-Stitch* Pattern Dial

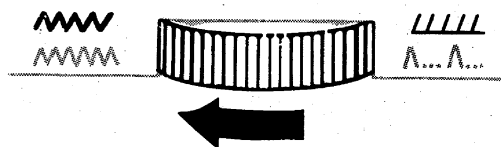

For Ric-Rac Stitch

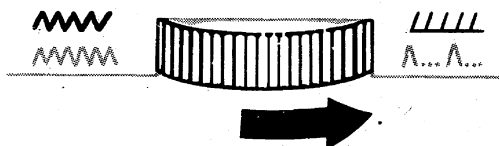

For Slant Overedge Stitch

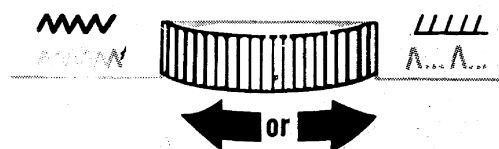

For Straight Stretch Stitch  
(at Stitch Width 0)

Setting Pattern Selector

## FLEXI-STITCH PATTERNS (Continued)

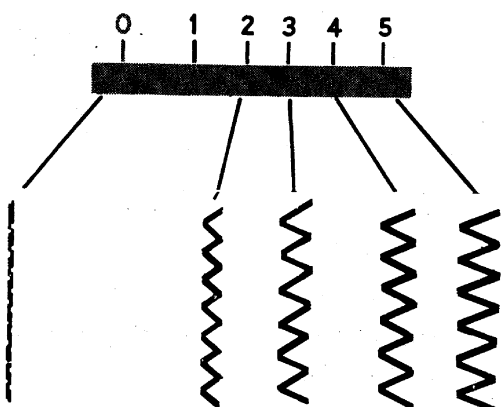

**Adjusting Width of Design**

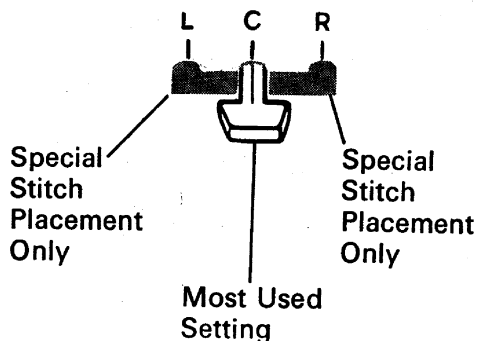

**Adjusting Stitch Placement**

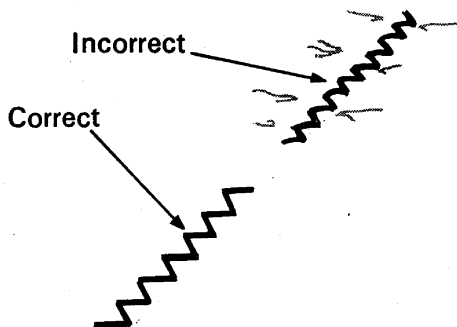
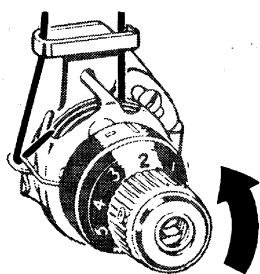

**Adjusting Needle-Thread Tension**

*Before moving needle position and stitch width selectors make sure needle is above fabric.*

### ADJUSTING WIDTH OF DESIGN

To produce a *Flexi-Stitch* pattern, the stitch width selector must be moved from the straight-stitch setting 0, to a setting from 2 to 5. The higher the number, the wider the stitch will be.

### ADJUSTING STITCH PLACEMENT

*Flexi-Stitch* patterns can be sewn in either L (left), C (center) or R (right) needle positions. Center needle position C is recommended.

### ADJUSTING NEEDLE-THREAD TENSION

Make a test sample with the fabric, thread, and presser foot you plan to use so that you can adjust tension to suit the stitch pattern you have chosen.

For your test sample, set the tension dial on 3 or 4. Notice the stitching; if the fabric puckers, decrease tension by turning the dial to a lower number. Sew at moderate speed.

## SETTING STITCH CONTROL DIAL

When you use a *Flexi-Stitch* pattern, stitch length is controlled with a *single setting* of the stitch control dial.

To set, turn dial until red bar — is centered under the pointer ▲ on the control panel.

**NOTE:** Stitching *cannot* be reversed when the *Flexi-Stitch* pattern dial is on red *Flexi-Stitch* pattern setting.

## STITCH CONTROL

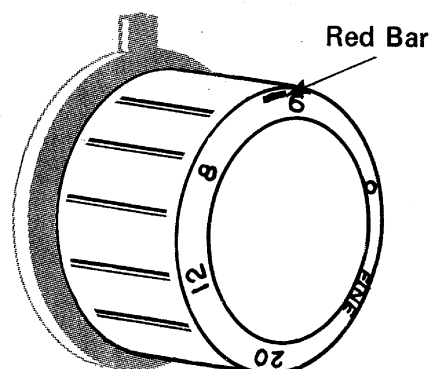

## ADJUSTING STITCH BALANCE

You may need to adjust the *Flexi-Stitch* pattern dial when using a *Flexi-Stitch* pattern in order to achieve the correct pattern appearance. Before you move the *Flexi-Stitch* dial from its neutral position (red bar ■ centered under ▼), make a test sample. If adjustment is required, stitch slowly and move the dial as you sew.

- Turn the dial to the right to bring stitches of the pattern together.
- Turn the dial to the left to separate stitches of the pattern.

### Stitch Control Dial

Incorrect Correct

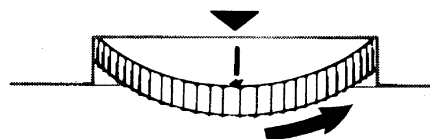
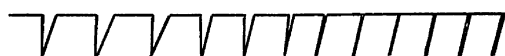

Turn Dial to Right to Bring Stitches Together

Incorrect Correct

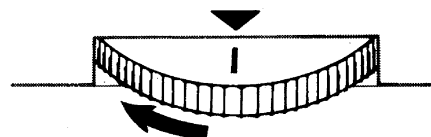

Turn Dial to Left to Separate Stitches

## ADJUSTING PRESSURE AND CHOOSING ACCESSORIES

Turn to page 18 under "Straight Stitching" for instructions on adjusting pressure.

For information on choosing accessories refer to detailed instructions for sewing with *Flexi-Stitch* patterns included in the section called "Sewing the Professional Way", which starts on page 36.

### Adjusting Stitch Balance

## TWIN-NEEDLE STITCHING

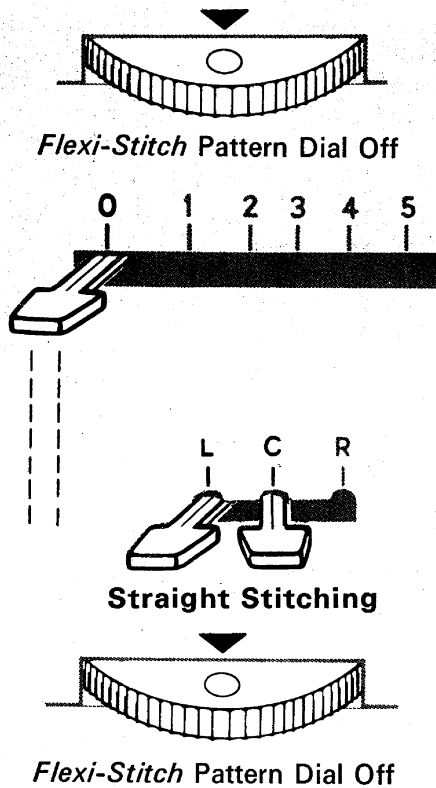

By using a twin needle, you can produce two parallel, closely spaced, decorative lines of stitching simultaneously. You can use either one or two colors of thread, and you can choose either a straight-stitch, zig-zag stitch, or blindstitch setting.

### SETTING THE MACHINE

#### Straight Stitching

- Flexi-Stitch Pattern Dial: **O** (Off)
- Pattern Selector: Any setting
- Needle Position: **C** or **L** only
- Stitch Width: **O**
- Stitch Length: Optional
- General Purpose Throat Plate
- General Purpose Foot

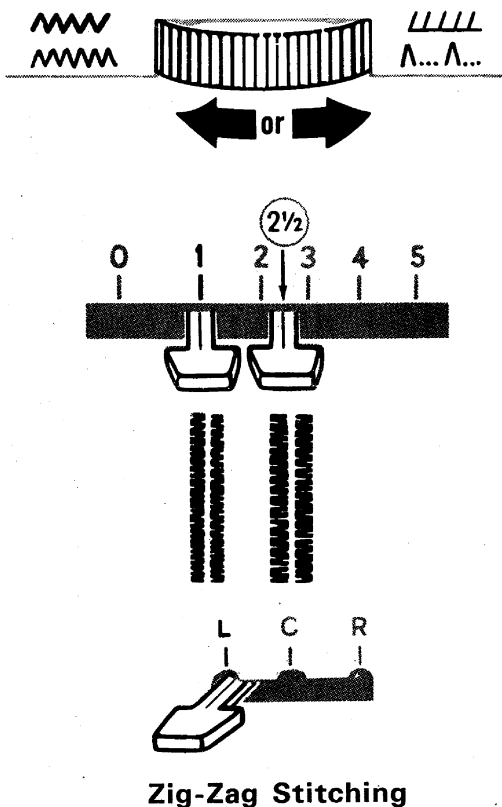

#### Zig-Zag Stitching

- Flexi-Stitch Pattern Dial: **O** (Off)
- Pattern Selector: **W** (for plain zig-zag) or **Λ...Λ** (blindstitch)
- Needle Position: **L** only
- Stitch Width: **2½** only
- Stitch Length: Optional
- General Purpose Throat Plate
- General Purpose Foot (Open Stitching)
- Special Purpose Foot (Satin Stitching)



Use SINGER\* twin needle, Style # 2028 (size 14).

## INSERTING THE TWIN NEEDLE

Before inserting the twin needle, make sure that the needle position selector is set at L and the stitch width selector is set at  $2\frac{1}{2}$  (or less).

To insert the twin needle, simply raise needle to highest point, loosen the needle-clamp screw. Remove single needle and insert the twin needle in its place. Tighten needle-clamp screw securely.

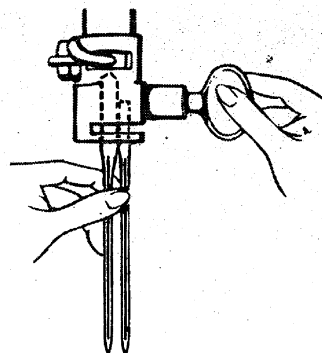

## THREADING FOR TWIN-NEEDLE STITCHING

For best results, use No. 50 mercerized cotton thread. Thread the machine in the same manner as for single-needle stitching except:

1. Be sure that threads are separated by center tension disc as they pass around tension assembly.
2. Carry both threads through the wire loop thread guide above the needle at the same time.
3. Carry only one thread through the last thread guide before the needle.

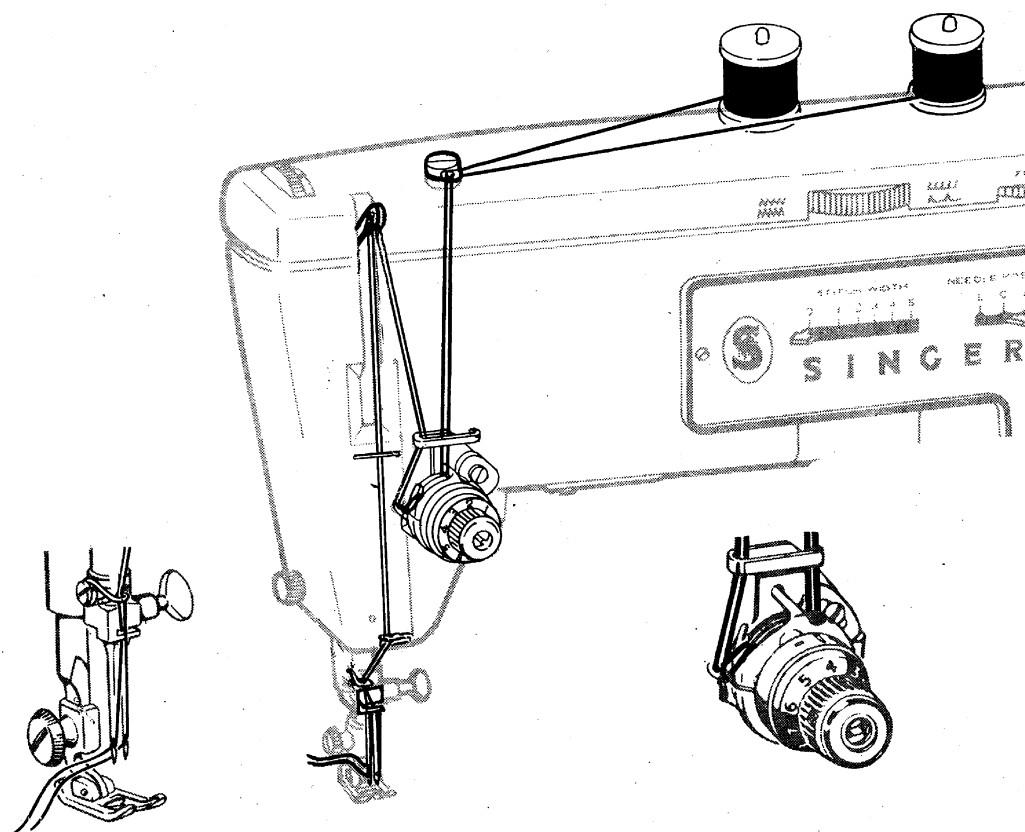

## BUTTONS

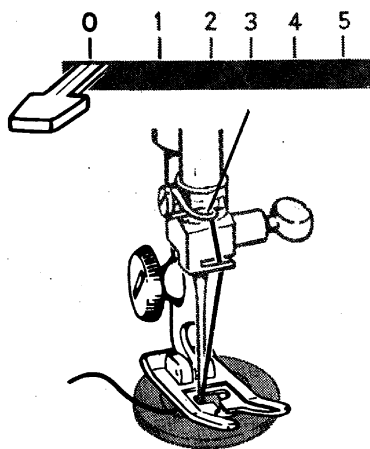

- *Flexi-Stitch* Pattern Dial : 0
- Pattern Selector : **W** (plain zig-zag)
- Needle Position : L (left)
- General Purpose Presser Foot
- Feed Cover Throat Plate

Flat buttons can be sewn on quickly and easily using the plain zig-zag stitch. The space between the holes in the button determines stitch width settings. For buttons with standard hole spacing, use settings 0 and 4. For buttons with unusual hole spacing, use setting 0 and increase or decrease the width (4) as necessary.

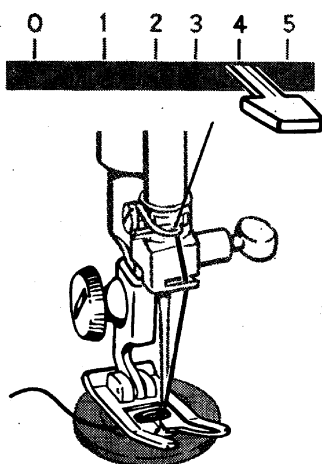

1. Attach feed-cover throat plate (see page 7), and turn *Flexi-Stitch* pattern dial to 0.

2. Set stitch width at 0. Position button under foot and lower needle into center of left hole by turning hand wheel toward you. Lower foot. Turn hand wheel toward you until needle rises out of button and is just above the foot.

3. Set stitch width at 4. Check setting by turning hand wheel slowly toward you; the needle should enter the right hole of the button. Take six or more zig-zag stitches to attach button. End on left side.

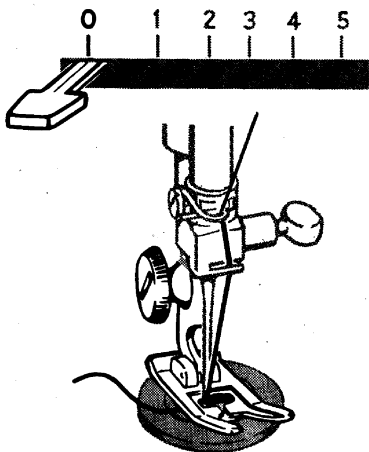

4. To fasten stitching, return to stitch width 0 and take three or four stitches.

Replace feed-cover throat plate with the general purpose throat plate when work is completed.

**NOTE:** For best results, and when using buttons less than one inch in diameter, the button sewing foot is recommended (see page 58).

# buttonholes

## BUTTONHOLE POSITION

Accurate guidelines are essential to keep buttonholes a uniform distance from the faced edge of the garment, evenly spaced, and on the grain of the fabric. For center closures, place guidelines as follows:

1. Mark the center line of the garment as indicated on your pattern. This guideline can be hand basted and should follow a lengthwise fabric thread.
2. Mark a position guideline for each buttonhole.
  - *Horizontal* buttonholes are placed to extend  $\frac{1}{8}$  inch beyond the center-line basting of the garment. Horizontal guidelines for the buttonholes should follow a crosswise thread of the fabric and, if basted, be longer than the finished length of the buttonhole. Determine the length of the buttonhole (as described below) and mark ends of each buttonhole vertically.
  - *Vertical* buttonholes are placed so that the center-line basting of the garment is in the center of the button holes. Determine buttonhole length and mark ends of each buttonhole horizontally across the center line and use the-center line basting as a buttonhole guide when stitching.

## BUTTONHOLE LENGTH

First, decide how long the button opening must be. Then, add  $\frac{1}{16}$  inch to the measurement for *each* bar tack (the closing stitches at each end of the buttonhole). To find the length of the button opening, cut a slit in a scrap of fabric the diameter of the button you intend to use. Increase length of opening until button slips through easily.

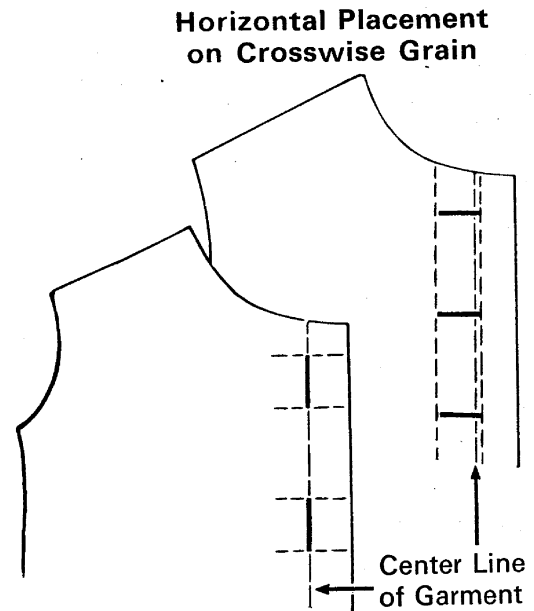

Horizontal Placement on Crosswise Grain

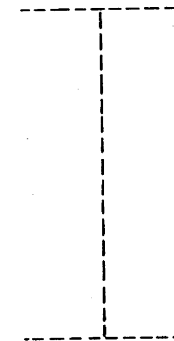

Vertical Placement on Lengthwise Grain

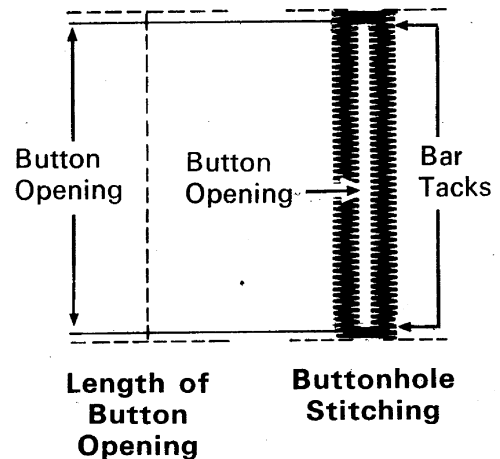

## STITCH WIDTH

Two stitch width settings are required for making buttonholes: one for side stitching and one for the bar tack. Three possible combinations are illustrated.

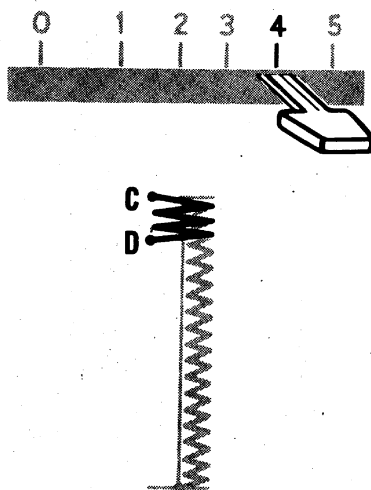
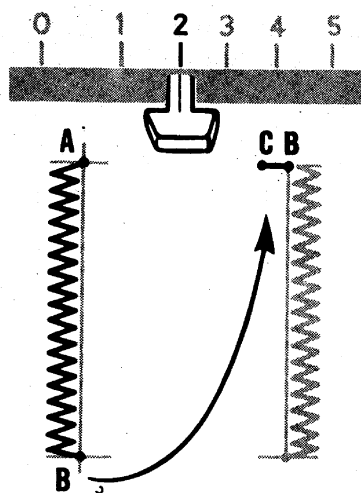
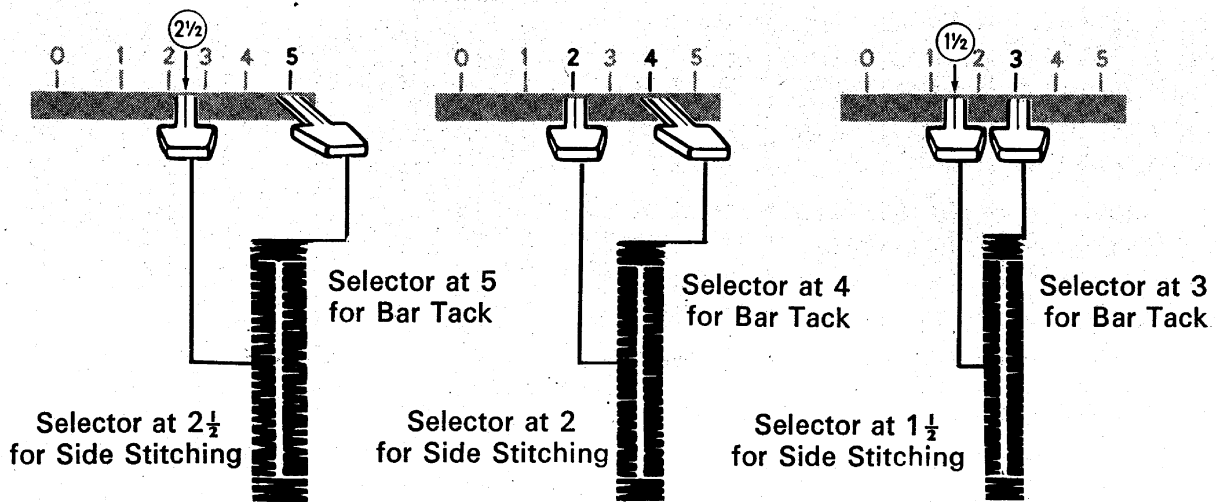

### Procedure

Set *Flexi-Stitch* pattern dial at 0 and set stitch length in FINE area of stitch control dial. Attach special purpose foot. Set the pattern selector at , needle position selector at L, and stitch width selector at the width desired for the side stitching. Place work under needle, aligning center marking of buttonhole with center slot in the special purpose foot.

### Side Stitching

Position needle in fabric at point A. Lower foot and stitch to end of marking. Leave needle in fabric at point B. Raise foot and pivot work on needle. Lower foot. Take one stitch without changing width setting, bringing work to point C.

### Bar Tack

Adjust stitch width selector for bar tacks and take at least six stitches. Stop at point D.

### Side Stitching

Readjust stitch width selector for side stitching. Complete work to point E. Leave needle in fabric.

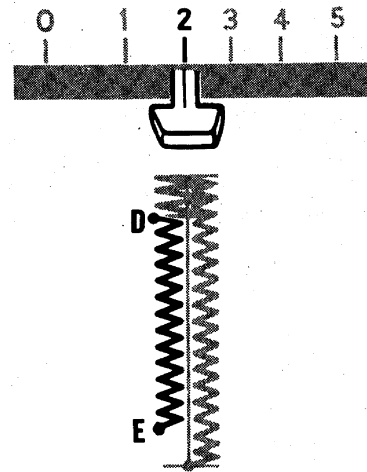

### Final Bar Tack

Adjust stitch width selector for bar tacks, and take at least six stitches ending at point F.

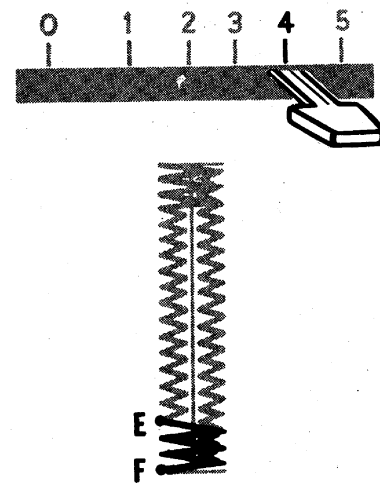

### Fastening Stitch

To secure stitching, move selector to 0 and take three stitches. Remove work, draw threads to underside, fasten, and trim. Cut opening for button with sharp scissors.

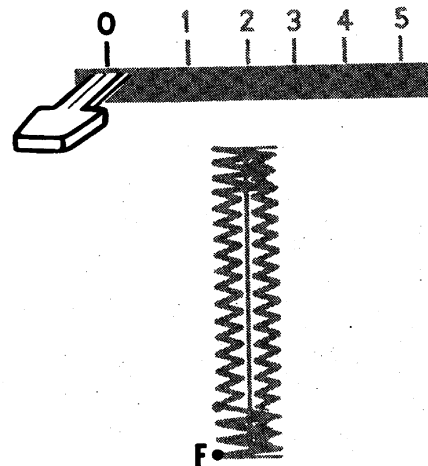





# SEWING THE PROFESSIONAL WAY

## *sewing knit and stretch fabric*

When you sew stretch fabric, doubleknit, tricot and jersey, choose one of the stitch patterns that sew stretch into the seam. A variety of different stitches are available so you can choose just the right one for your fabric and sewing job. The table below will help you make the right selection.

Remember to use a ball-point needle (Style # 2045) in the machine and increase presser bar pressure when you attach elastic or sew a synthetic knit or stretch fabric.

### STRETCH STITCH CHART

Stitch	Where to Use
 Straight Stretch Stitch	Plain seams that s-t-r-e-t-c-h (press-open or closed construction) — Crotch seaming — Sleeve and gusset insertion — Flexible top stitching — Swim and ski suit construction — Attaching patch pockets — Repairing and reinforcing seams.
 Plain Zig-Zag Stitch	All-purpose stretch sewing — Lingerie seams — Attaching stay tapes — Seam finishing — Edge finishing — Attaching stretch lace.
 Blindstitch	Flexible blindstitch hemming — Overcast seam finishing — Shell hems in lingerie — Ladder Seams — Blindstitch zipper insertion.
 Ric-Rac Stitch	Heavy-duty, all-purpose stretch sewing— Reversible topstitch applications.
 Slant Overedge Stitch	Overedged seams that stretch in sportswear, knitwear, slacks, and bathing suits.

## PLAIN STRETCH SEAMS

- *Flexi-Stitch* Pattern Dial: Red |
- Pattern Selector: Any Setting
- Needle Position: C
- Stitch Width: 0
- Stitch Length Dial: Red —
- General Purpose Throat Plate
- General Purpose or Special Purpose Foot
- Speed: Moderate

When you use the straight stretch stitch to seam knit, stretch, and elasticized fabric, *s-t-r-e-t-c-h* and strength are built in as the seam is being sewn. Because it is equally useful for closed or press-open seam construction and will not break thread under stress, the straight stretch stitch is also good for seams that receive an unusual amount of strain when worn. For example: crotch seaming, sleeve insertion, and construction seams in sportswear and bathing suits.

### Procedure

1. Make a test sample to determine thread tension and stitch balance.

## GUIDING AND SUPPORTING FABRIC

Most fabrics of stretch or knit construction need only to be guided in front of the presser foot when you use one of the stretch stitches. Simply increase presser bar pressure and let the machine move the fabric to make the stitches that give *s-t-r-e-t-c-h* to the seam.

Some fabrics, however, require support while being stitched.

- For nylon tricot, ciré, pannelé velvet and similar synthetic knits, apply *gentle* tension by holding fabric taut in front *and* back of the presser foot as you sew.
- For elasticized fabric, stretch lace, and knits with an unusual amount

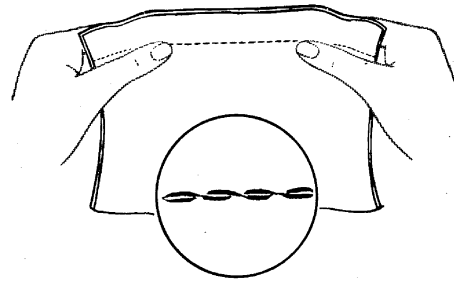

**Straight Stretch Stitching**

Be sure to insert a ball-point (yellow band) needle in machine if you are stitching a synthetic knit fabric, and increase presser bar pressure if necessary.

2. Stitch and guide fabric as you do for plain seams stitched with the regular straight stitch, letting the machine make the back-and-forth stitches that give *s-t-r-e-t-c-h* to the seam. If fabric has an unusual amount of elasticity, it should be stitched under tension as instructed under "Guiding and Supporting Fabric" (see below).
3. Press seam as when using the regular straight stitch.

of elasticity, apply *firm* tension in front and back of the presser foot to stretch the seam as the stitches are being placed.

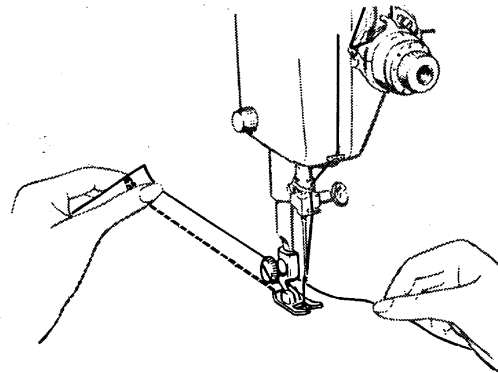

**Applying Gentle Tension**

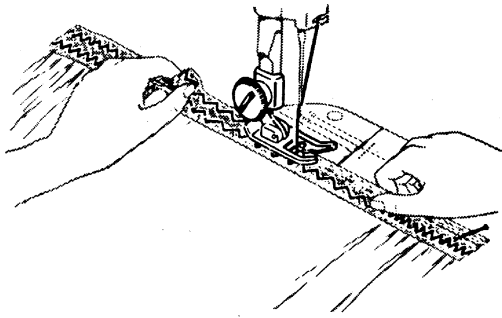

**Attaching Elastic with Plain Zig-Zag**

## ATTACHING ELASTIC

Elastic will remain stretchable when it is attached with the plain zig-zag stitch. The flexible joining produced by this stitch allows elastic banding to be stitched under, over, or between fabric layers, making it particularly useful in the construction of lingerie and swim suits.

- *Flexi-Stitch* Pattern Dial : **O** (off)
- Pattern Selector : **MM** (plain zig-zag)
- Needle Position : **C** (center)
- Stitch Width : **4-5**
- Stitch Length : About **20**
- General Purpose Throat Plate
- General Purpose Foot

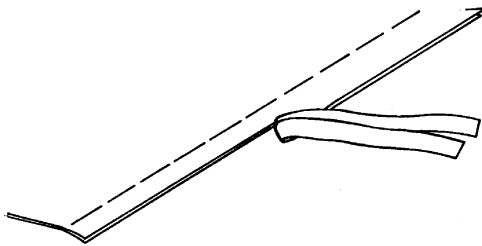

**Trimming Seam Edges**

## OVEREDGED SEAMS

Seams in knit and stretch fabrics can be joined and finished in one operation with slant overedge stretch stitch.

- *Flexi-Stitch* Pattern Dial : Red **I**
- Pattern Selector : **///** (slant overedge)
- Needle Position : **C** (center)
- Stitch Width : **5**
- General Purpose Throat Plate
- General Purpose Foot
- Speed : Moderate

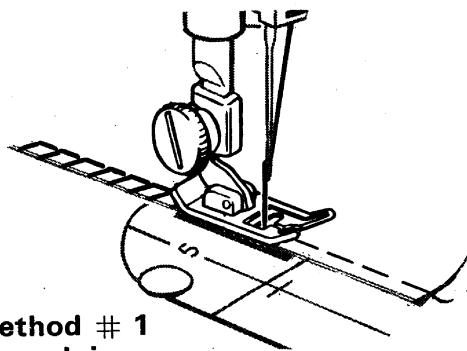

**Method # 1 Overedging**

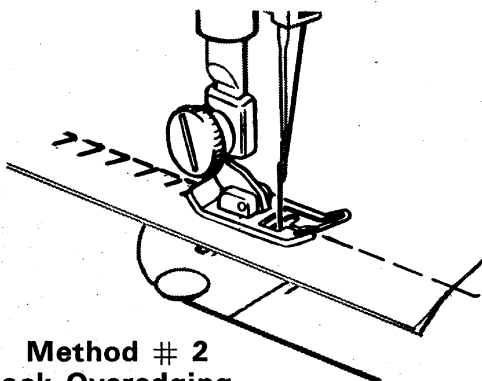

**Method # 2 Mock Overedging**

Two different methods may be used. Method # 1 (overedging) is recommended for firm fabrics in garments where a  $\frac{1}{4}$ -inch seam allowance is adequate. Method # 2 (mock overedging) is most appropriate for bulky knits and fabrics that have a tendency to curl or fray and should be used where a wider seam allowance is needed. Make a test sample to help you decide which method is best for your fabric and garment. Be sure to duplicate the cut of the garment seam in your test.

Remember to use a ball-point (yellow band), Style 2045, Size 14 needle in your machine if you are sewing a synthetic knit.



## LADDER SEAMS

A ladder seam made with blindstitching is both functional and decorative. Particularly appropriate for knit and stretch fabrics, the blindstitch provides stretchable, decorative construction seams, and edge finishes for necklines, pockets and collars in sportswear and swimwear.

- *Flexi-Stitch* Pattern Dial: **O** (off)
- Pattern Selector:  $\Lambda... \Lambda$  (blindstitch)
- Needle Position: **C** (center)
- Stitch Width: **5**
- Stitch Length: **10 to 15**
- Thread Tension: Lighter than normal
- General Purpose Throat Plate
- General Purpose Foot

After stitching, open seam by pulling fabric back on opposite sides of seam to produce ladder effect. Press seam allowances of construction seams to one side. Seam allowances of enclosed seams are pressed together in the usual way after seam has been opened.

## FINISHES FOR HEMS AND FACINGS

Hems and facing edges in knit and stretch fabrics will be less apt to press through and mark when given a flat edge finish. Edge finishing with the plain zig-zag stitch or blindstitch eliminates the bulk of turned-in edges and retains fabric flexibility.

- *Flexi-Stitch* Pattern Dial: **O** (off)
- Pattern Selector:  $\text{M}\text{M}\text{M}$  (plain zig-zag) or  $\Lambda... \Lambda$  (blindstitch)
- Needle Position: **C** (center)
- Stitch Width: **5**
- Stitch Length: **8-20** (depending on fabric)
- General Purpose Throat Plate and Foot

1. Make a test sample.
2. Place stitching about  $\frac{1}{2}$  inch from hem or facing edge.
3. Press after stitching and trim away excess fabric close to the stitching line.

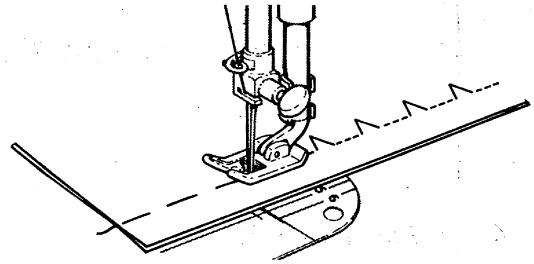

**Blindstitching Ladder Seam**

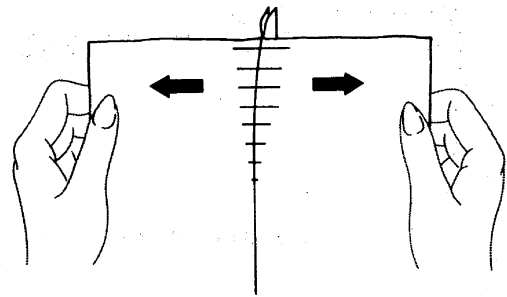

**Opening Seam to form Ladder Effect**

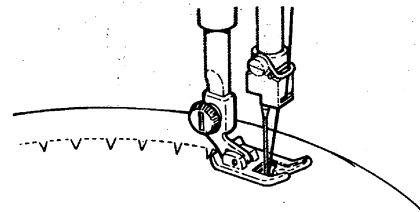

**Applying Facing Finish**

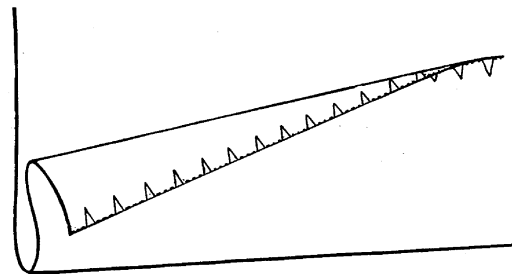

**Finished Hem Edge**

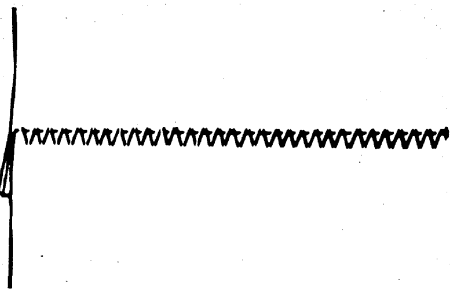

For a  $\frac{5}{8}$ -inch Seam

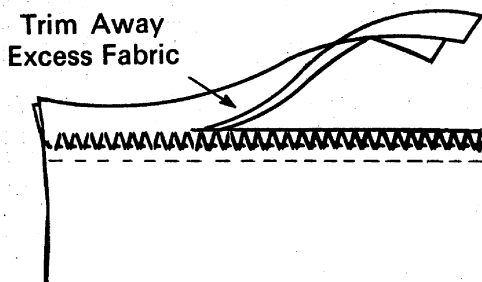

For a Narrow Seam

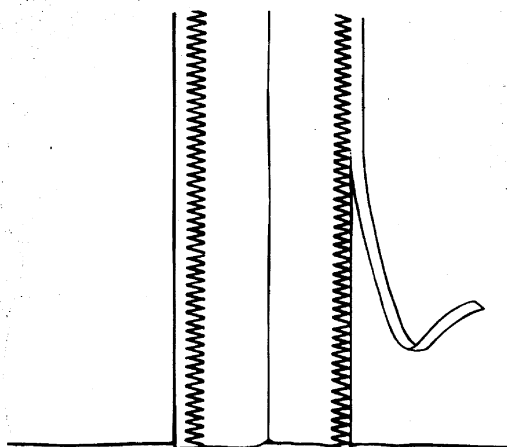

Trimming Seam Edges after Stitching

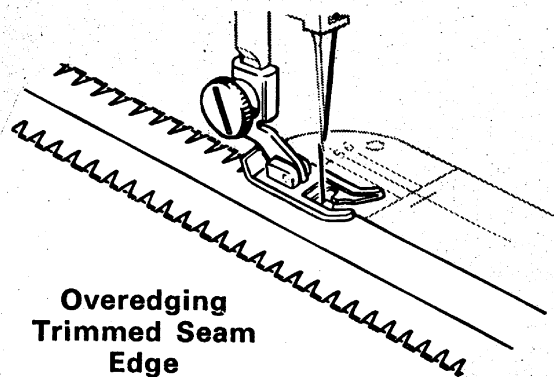

Overedging  
Trimmed Seam  
Edge

## LINGERIE SEAMS

To make seams in lingerie durable and flexible, use a combination of straight and zig-zag stitching.

### Method # 1

For  $\frac{5}{8}$ -inch bias seam in woven fabric:

- Straight-stitch the seam (with stitch width at 0) on wrong side of fabric.
- Press both seam allowances in the same direction. Then, from the right side, top-stitch with narrow zig-zag stitching, letting needle alternately enter seam line and seam thickness.

### Method # 2

For narrow seams in nylon tricot:

- Cut fabric for  $\frac{5}{8}$ -inch seam allowance.
- Straight-stitch seamline on wrong side of fabric. Then place a line of medium-wide, open zig-zag stitching close to the straight stitching. (Stitch width  $3\frac{1}{2}$  to 4; stitch length 20.)

## SEAM FINISHES

- *Flexi-Stitch* Pattern Dial: **O** (off)
- Pattern Selector: **MM** (plain zig-zag) or **Λ...Λ** (blindstitch)
- Needle Position: **C** (center)
- Stitch Width: **4** or **5**
- Stitch Length: **8-20**, depending on choice of stitch and fabric
- General Purpose Throat Plate and Foot

Seam edges support the garment and should be given a durable finish if the fabric is likely to ravel. There are two methods of finishing seams in such fabrics: trimming seam edge or overedging. Make a test sample first to determine which method best suits your fabric.

## *hints on sewing special fabrics*

### **LEATHER-LOOK VINYL**

- Use masking tape or zipper adhesive tape instead of pins or basting to hold seams, zippers and hems in place for stitching.
- Stitch with a long stitch (8 to 10 straight stitches per inch). A short stitch may cut the fabric.
- Sew with a steady, even pace and stitch accurately. Seams cannot be ripped out without leaving needle marks in the fabric.
- The shiny side of some vinyls tends to stick to metal surfaces. Use a strip of tissue paper between the fabric and metal machine surfaces to prevent this. Other remedies include dusting fabric with talcum powder or wiping surface with a damp sponge.
- Reinforce button and buttonhole areas with interfacing. Bound buttonholes are the best choice for vinyls with knit backing.
- Top stitching holds seams and garment edges smooth and flat and adds a decorative note.
- For sharp points on collars and lapels, take one or two stitches diagonally *across* the point to allow enough space to smoothly enclose the seam edge.

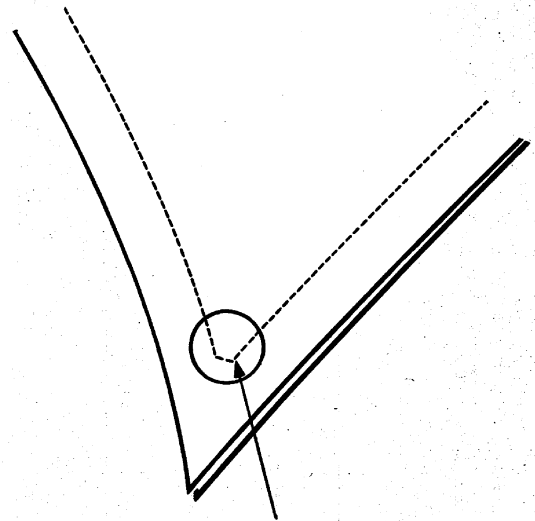

**Diagonal Stitching  
Across the Point**

### **CIRÉ (Wet-Look Taffeta and Tricot)**

- Do not use pins in any area of the garment that will be visible when completed.
- Use masking tape or zipper adhesive tape instead of pins or basting to hold seams, zippers, and hems in place for stitching.
- Stitch accurately; seams cannot be ripped out because needle marks remain in the fabric.
- Sew seams under light tension by holding fabric slightly taut at front and back of needle.
- Stitch ciré taffeta with a fairly long stitch (8-10 straight stitches per inch) and use an enclosed edge finish for seams and hems.
- Stitch ciré knits with a medium-length stitch (12 straight stitches per inch) and use a fine ball-point needle.
- Machine-worked buttonholes (as well as bound buttonholes) can be made in ciré fabric. Always use an interfacing and make sure the close zig-zag stitches do not cut the fabric.

### DEEP-PILE FABRICS (Fake Fur)

- Pin, rather than baste, seams. Place pins at close intervals at right angles to the seamline. Pins with colored heads are easy to see and remove.
- Sew in direction of nap.
- Stitch with a fairly long machine stitch (8 to 10 straight stitches per inch) and use polyester/cotton thread in a size 14 or 16 Style # 2020 needle.
- As seam is stitched, smooth pile away from seam allowance with a darning needle or upholstery pin.
- After stitching seams with a  $\frac{5}{8}$ -inch seam allowance, use small hand scissors to shear pile from entire seam allowance to reduce bulk.
- Stitch  $\frac{1}{4}$ -inch pre-shrunk tape into neckline and shoulder seams for stability and reinforcement or stitch with the straight stretch stitch.
- Leather and leather-look fabrics complement fur fabrics; use them for bound buttonholes and easy button loops.
- Coat hems are less bulky if they are narrow and finished with a 3-inch fabric facing or grosgrain ribbon.
- Slash through the center fold of darts and finger-press open, or stitch with a narrow zig-zag stitch and trim away excess fabric after stitching.

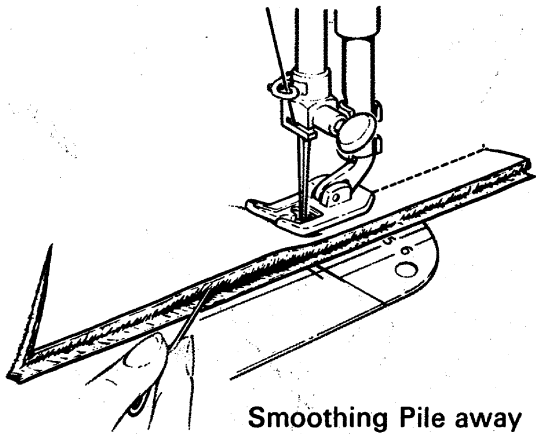

Deep-Pile Fabrics

### VELVET AND VELVETEEN

- Use a light-pressure dial setting to prevent crushing pile.
- Mark and baste with silk thread.
- Use a Style # 2020, size 11 needle, and a fine thread for seaming. "A" silk or nylon thread is recommended for velvet.
- Always stitch in the direction of the nap.
- For unpuckered seams, pin or hand baste together and then stitch under light tension (see page 19). Extra-long, straight seams may be machine basted with a long, wide zig-zag stitch.
- When inserting a zipper, use the blindstitch for an almost invisible finish (see page 44).
- To sew panné velvet, use a ball-point needle and a shorter-than-normal stitch length (12 to 15 straight stitches per inch).

## construction details

### ZIPPERS

At the notions counter in your Singer Sewing Center, you will find many different kinds of zippers, one of which will be just right for whatever you want to sew. The zipper package will contain easy-to-follow instructions for inserting the zipper. And, with the zipper foot, you will find it easy to form an even line of stitching close to the zipper.

- Flexi-Stitch Pattern Dial: **O** (off)
- Pattern Selector: Any setting
- Needle Position: **C**
- Stitch Width: **O**
- General Purpose Throat Plate
- Zipper Foot

#### Attaching the Zipper Foot

When the zipper is to the *right* of the needle:

- Move position block on zipper foot to left, to allow shank to enter right side of foot, so that needle will enter right notch in foot.

When the zipper is to the *left* of the needle:

- Move position block on zipper foot to right, to allow shank to enter left side of foot, so that needle will enter left notch in foot.

(The zipper foot is snapped onto shank as instructed on page 7.)

### CORDED SEAMS

The corded seam is a professional treatment for slipcovers, children's clothes, blouses, and lingerie. To make a corded seam, make the welting first (or buy it ready-made at a notions counter), then stitch it into the seam. For both steps, use the zipper foot to place the stitching close to the cord.

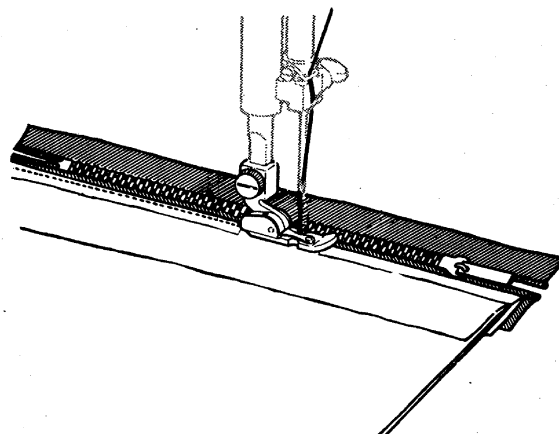

Zipper Insertion

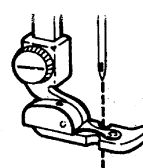
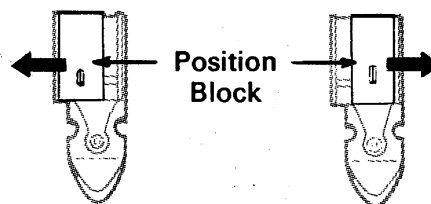

Zipper Foot  
to Left of Needle

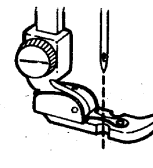

Zipper Foot  
to Right of Needle

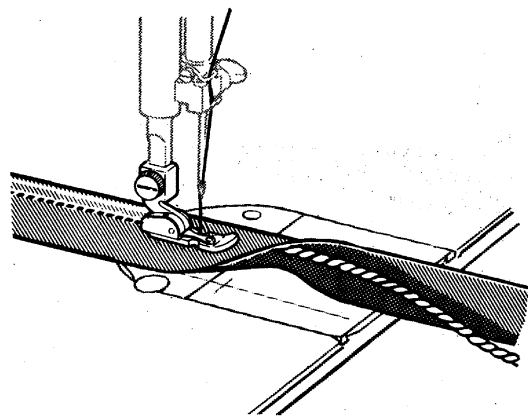

Making Welting for a  
Corded Seam

## BLINDSTITCH ZIPPER INSERTION

- *Flexi-Stitch* Pattern Dial : O (off)
- Pattern Selector :  $\wedge \dots \wedge$  (Blindstitch)
- Needle Position : L
- Stitch Width : 2
- Stitch Length : 12
- Zipper Foot
- General Purpose Throat Plate

Blindstitching, used instead of straight stitching for the final step in zipper insertion, gives a fine finish that is almost invisible. Indispensable for knits, napped fabrics, and sheers.

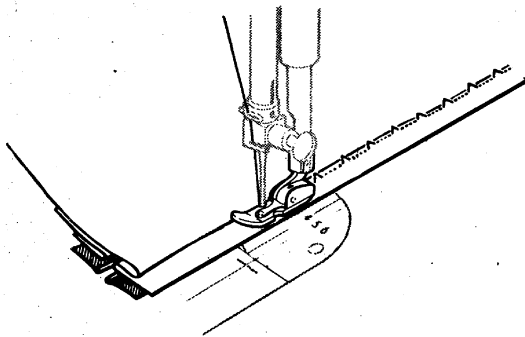

**Final Step of Blindstitch Zipper Insertion**

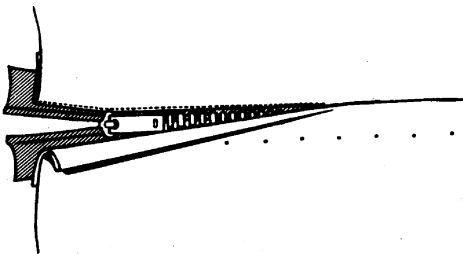

**Completed Blindstitch Zipper Insertion**

1. Allow for a  $\frac{7}{8}$ -inch seam allowance in the zipper area when you cut garment.
2. Insert zipper in the usual way up to the final step ; then, turn garment right side out and spread flat with zipper face up.
3. Work from the right side and pin zipper tape into position.
4. Baste a guideline for blindstitching alongside zipper, about  $\frac{3}{8}$  inch from garment seam. Make sure basting stitches go through all fabric layers and zipper tape. Remove pins.
5. Adjust zipper foot to right side of needle.
6. Turn garment wrong side out. Place lower end of zipper tape over feed and turn front section of garment back to line of basting, creating a soft fold to the left of the needle.
7. Set stitch width selector and position work so that the straight stitches will go through the seam allowance and zipper tape, and the sideward stitches catch a few threads of the fold.
8. Lower zipper foot and stitch slowly. After stitching, remove basting and press lightly.

## BLINDSTITCH HEMS

- *Flexi-Stitch* Pattern Dial: **O** (off)
- Pattern Selector:  $\Lambda$ ... $\Lambda$  (blindstitch)
- Needle Position: **L** or **C**
- Stitch Width: **2-5**
- Stitch Length: **10-20**
- General Purpose Throat Plate
- General Purpose Foot

Blindstitching provides a durable hem finish that can be used on a variety of light and medium weight fabrics. It is best suited to straight hems. Taped, bound, turned, or unfinished hem edges can be blindstitched with equal ease. Blindstitching takes a little practice, however, so make a test sample first.

1. Mark, turn, and press hem in the usual way. (You may want to baste the turned hem to hold it in place. If so, be sure to place the basting at least  $\frac{1}{2}$  inch below the top edge of the hem.)
2. With the work wrong side up, turn the hem under, creating a soft fold about  $\frac{1}{4}$  inch from the top edge of the hem. Press lightly.
3. Position the hem under the foot.
4. Lower the foot and stitch so that the straight stitches fall on the hem edge and the sideward stitches pierce the soft fold.

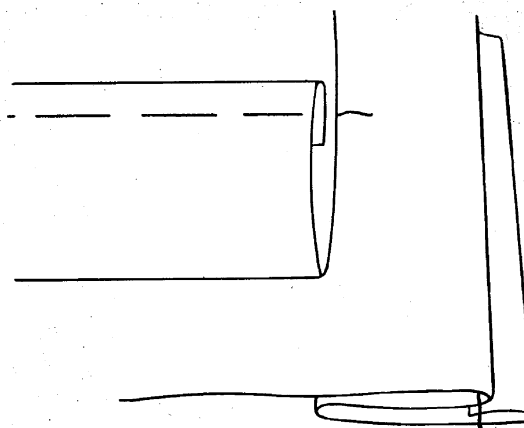

**Turn and Press Hem**

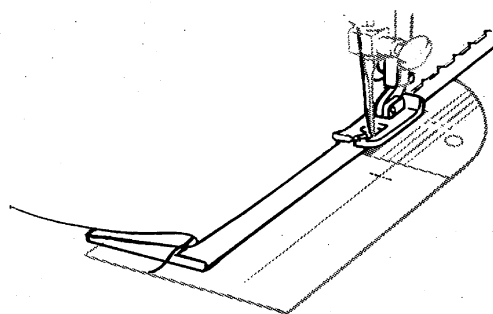

**Blindstitching Hem**

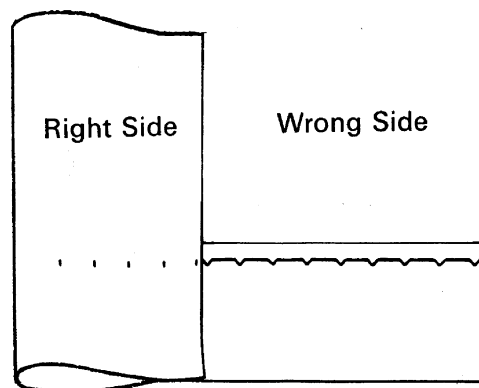

**Blindstitch Hem Completed**

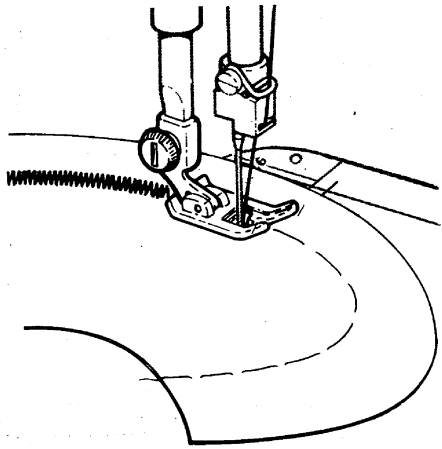

## TOPSTITCHING

A practical, simple way to accent the lines of a dress or coat is to place one or more rows of stitching along collars, lapels, facing edges, pockets, seams, etc. For a tailored look, use lines of regular straight stitching; sew them with buttonhole twist for added emphasis. For decorative interest, use a zig-zag or *Flexi-Stitch* pattern. To add firmness to hems and seams in knit and stretch garments, topstitch with the straight stretch stitch. The seam guide (see page 59) will help you place stitching accurately.

## DARTS IN INTERFACING

- *Flexi-Stitch* Pattern Dial: **O** (off)
- Pattern Selector: **MM** (plain zig-zag)
- Needle Position: **C**
- Stitch Width: **5**
- Stitch Length: **20** or to suit Fabric
- General Purpose Throat Plate
- General Purpose Foot

With zig-zag stitching, interfacings can be shaped without bulk.

1. Cut out the dart allowance on the stitching line.
2. Bring raw edges together and pin or baste in place over a muslin stay.
3. Stitch, backstitching at both ends of dart for reinforcement.

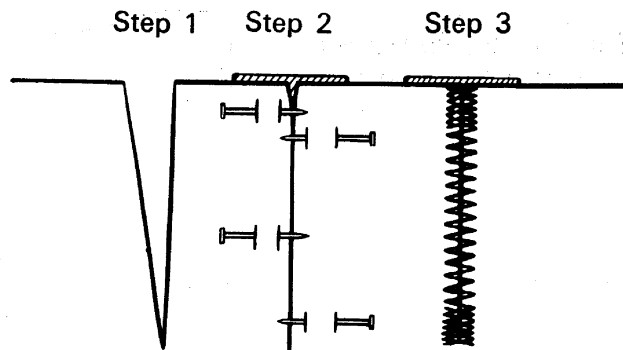

Steps in Making a Dart in Interfacing



# *decorative touches*

## **APPLIQUE**

Applique adds beauty and interest to clothing and household linens. You can create your own design, trace a simple outline from a coloring book, or use a motif cut from a printed fabric. Fabrics of like or different texture combine equally well.

A closely spaced zig-zag stitch is most commonly used in applique work, but other stitch patterns may also be used effectively. Although you may vary stitch width to accommodate fabric weave or texture, never allow the stitch to be too wide.

When appliqueing, make a test sample to help you decide which of the following methods is more appropriate for your fabric and design.

### **Preparation**

- Baste applique design to fabric.
- Outline design with straight stitching (use a short stitch).
- Remove basting and press.
- Attach special purpose foot.

### **Method # 1 — Trimming after Stitching**

1. Set machine for desired applique stitch and set stitch width. Adjust stitch length in the FINE area of the stitch length dial.
2. Outline the entire design with applique stitching.
3. Cut away the fabric on the outer edges of the stitching with embroidery scissors.

### **Method # 2 — Stitching after Trimming**

1. Trim outside fabric edges close to straight stitch outline of design.
2. Set machine for plain zig-zag stitching and set stitch width. Adjust stitch length in the FINE area of the stitch length dial.
3. Overedge the design with zig-zag satin stitching. This step will produce a smooth, lustrous finish that requires no additional trimming.



**Method 1**  
**Trimming after Stitching**

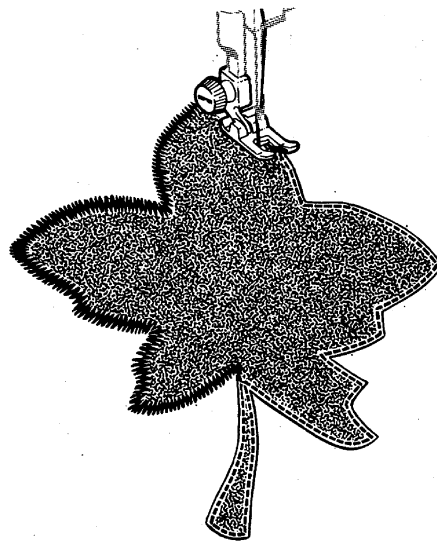

**Method 2**  
**Stitching after Trimming**

## SHELL EDGING

- *Flexi-Stitch* Pattern Dial: **O** (off)
- Pattern Selector:  $\Lambda \dots \Lambda$  (blindstitch)
- Needle Position: **C**
- Stitch Width: **3 to 5**
- Stitch Length: **12 to 25**
- General Purpose Throat Plate
- General Purpose Foot

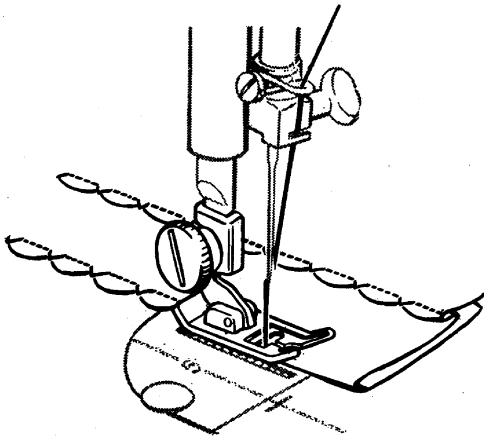

**Shell Edging with  
the Blindstitch**

On soft, fine fabrics such as tricot, voile and crepe, shell edging makes an attractive finish for narrow hems or bias folds in blouses, slips and petticoats.

Make a test on a sample of your fabric to find the right thread tension, stitch length, and stitch width.

1. Place folded hem (basted, if necessary) or bias fold under presser foot, with hem or fold to the left.
2. Stitch slowly, guiding fabric so that the sideward stitches are made *over* the folded edge.

# keeping up appearances

## MENDING

The plain zig-zag pattern is just as useful for mending as it is for creative sewing. It forms a flexible bond for repairing tears and stretch garments.

### Mending a Tear

- *Flexi-Stitch* Pattern Dial : **O** (off)
- Pattern Selector : **MM** (plain zig-zag)
- Needle Position : **C** (center)
- Stitch Width : **4** or **5**
- Stitch Length : About **20**
- General Purpose Throat Plate and Foot

1. Trim ragged edges.
2. Place underlay on the wrong side of tear for reinforcement. (It is best not to baste or pin the underlay since you will be bringing the edges of tear together in the next step.)
3. Stitch on the right side, bringing the edges of the tear together.
4. Shorten stitch length at ends and corners to give extra strength.
5. Trim underlay.

### Bar Tacks

Bar tacks, to reinforce points of strain, are made with the plain zig-zag stitch at satin stitch length. Use them at pocket corners, to attach garters, secure shoulder straps, belt loops and zipper openings.

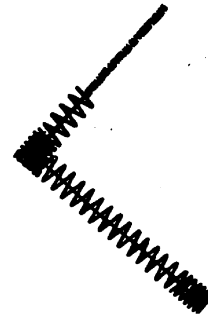

**Tear Mended with Plain Zig-zag**

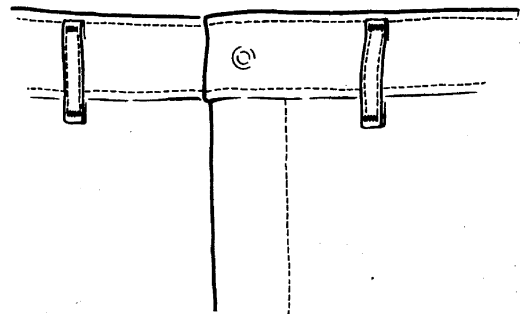

**Bar-Tacked Belt Loops**

## Repairing Stretch Garments

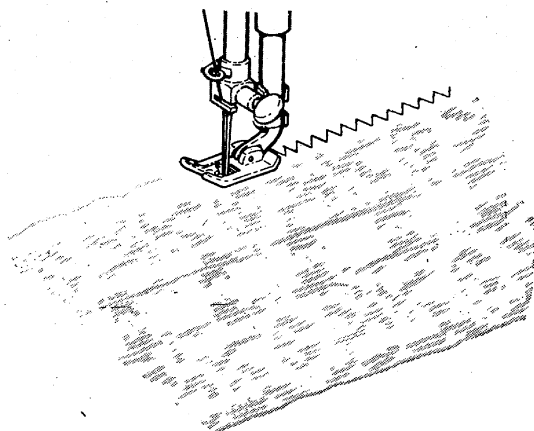

- *Flexi-Stitch* Pattern Dial: **O** (off)
- Pattern Selector: **W** (plain zig-zag)
- Needle Position: **C** (center)
- Stitch Width: **3** to **5**
- Stitch Length: **20** or to suit fabric
- General Purpose Throat Plate and Foot

Seams and hems in stretch and elasticized garments retain their elasticity when stitched with the plain zig-zag stitch. This stitch is particularly effective when used in topstitch applications (as shown) or to overedge. Make a test sample to check selector settings.

### Stretch Garment Repair

## Repairing Seams

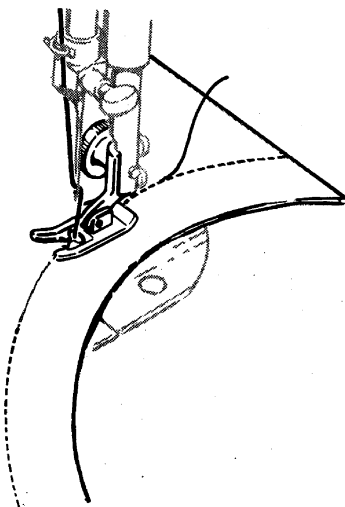

Breaks in press-open seams can be repaired quickly and easily when you use the straight stretch stitch. This stitch is ideal for knit and stretch fabrics, and particularly useful for repairing or strengthening curved seams, or seams that will receive strain when worn.

1. Make a test sample to check dial settings.
2. Remove loose thread along the break and press seam edges *together*.
3. Re-stitch along original seamline, guiding seam under presser foot without stretching fabric, letting the machine move the fabric to make the back - and - forth stitches that give *s-t-r-e-t-c-h* to the seam. Overlap stitching one inch at each end. Press seam open.

### Seam Repair

## DARNING

Worn or torn spots on children's clothes, knits, and household linens can be darned effortlessly and quickly with little practice. You may choose to darn either with or without an embroidery hoop. When greater control is needed, an embroidery hoop is usually best.

### Darning without Embroidery Hoop

- *Flexi-Stitch* Pattern Dial: **O** (off)
- Pattern Selector: Any setting
- Needle Position: **C**
- Stitch Width: **0**
- Stitch Length: **12**
- General Purpose Throat Plate
- General Purpose Foot
- Pressure: **D**

1. If area to be darned is open, baste an underlay in place.
2. Place area to be darned under presser foot; lower presser foot and start stitching, alternately drawing fabric toward you and pulling it *gently* away from you.
3. Continue this forward and backward motion as you fill the area with parallel lines of stitching. For additional strength, cover area with crosswise lines of stitching.

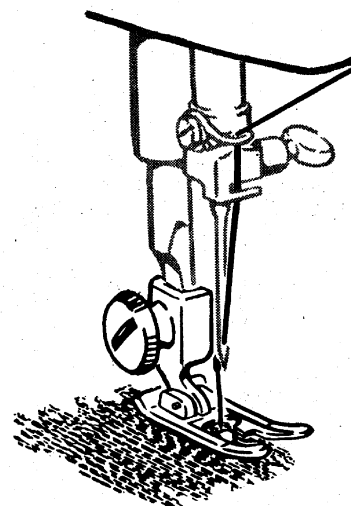

**Darning Without Embroidery Hoop**

## Darning with Embroidery Hoop

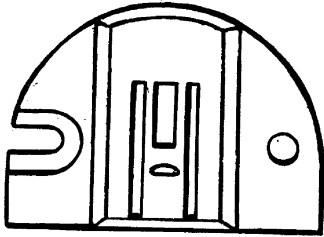

**Feed Cover Throat Plate**

- *Flexi-Stitch* Pattern Dial : 0 (off)
- Pattern Selector : Any setting
- Needle Position : C
- Stitch Width : 0
- Stitch Length : In Fine Area
- Feed Cover Throat Plate
- No Presser Foot
- Presser Bar : Lowered

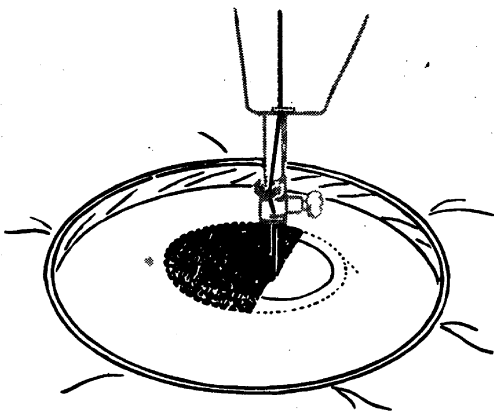
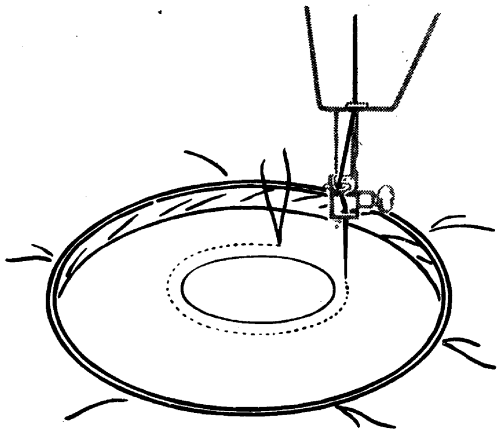

**Darning With Embroidery Hoop**

### Preparation

Remove presser foot with shank (by removing the screw which fastens the shank to the presser bar). Attach feed cover throat plate. Instructions for changing the throat plate are given on page 7.

1. Trim ragged edges from area to be darned.
2. Center worn section in embroidery hoop.
3. Position work under needle over feed cover plate and *lower presser bar to engage tension*.
4. Hold needle thread loosely with left hand, turn hand wheel over and draw bobbin thread up through fabric. Hold both thread ends and lower needle into fabric.
5. Outline area to be darned with running stitches for reinforcement.
6. Stitch across opening, moving hoop under needle at a slight angle from lower left to upper right. Keep lines of stitching closely spaced and even in length.
7. When opening is filled, cover area with crosswise lines of stitching.

This method of controlling fabric movement with an embroidery hoop may be used to do embroidering and monogramming.

## CARING FOR YOUR MACHINE

### *cleaning the machine*

Your machine will serve you perfectly for many years if you take a few moments of your time to keep it clean. How often you will need to clean the machine will depend on how often you use it.

**CAUTION:** Before cleaning your machine, disconnect power-line plug from electrical supply.

Remove lint or fluff from exposed parts. With a soft cloth, clean :

- Tension discs, take-up lever, and thread guides.
- Presser bar and needle bar.
- Bobbin case. (If there is an excessive amount of lint in the area, remove the bobbin case for cleaning. See page 55 for instructions.)
- Machine surface. (If necessary, dampen the cloth and use a mild soap.)

Remove face plate as instructed on page 54, and clean area behind it with a lint brush †.

Remove throat plate as instructed on page 7 and, using a brush, clean the rotating hook area under the throat plate and slide plate.

After cleaning, apply SINGER\* oil at points indicated on these pages.

Approximately once every year under normal conditions, clean and lubricate all moving or rotating machine connections to ensure freedom of movement and to protect metal parts from excessive wear. To remove top and bottom covers, follow instructions on page 54.

†A lint brush designed for this purpose is available for separate purchase at your local Singer Sewing Center.

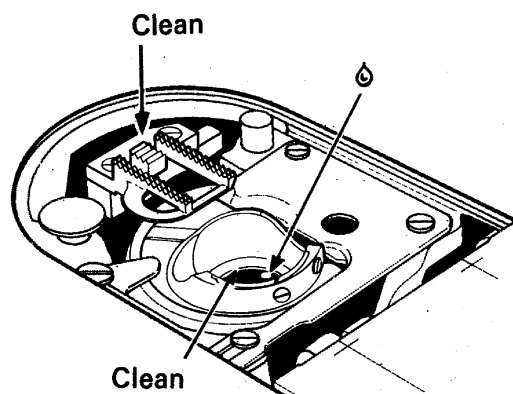
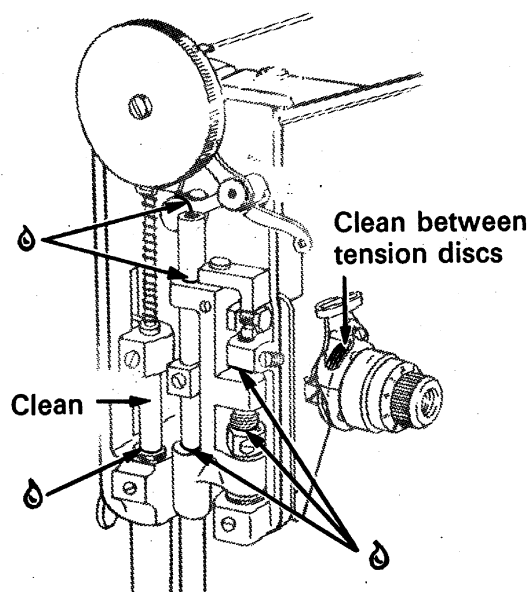

## removing covers, bobbin case and bulb

**CAUTION:** Before removing covers, bobbin case, and light bulb, disconnect power-line plug from electrical supply.

### REMOVING AND REPLACING TOP COVER

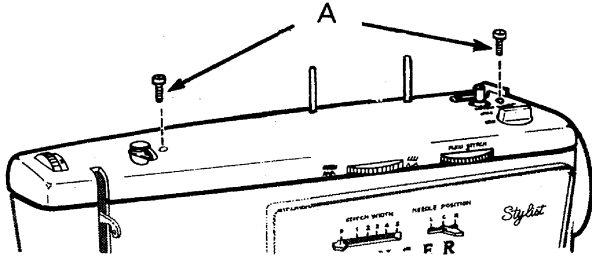

- To remove, loosen and remove screws A and lift off top cover.
- To replace, position cover on top of machine and replace and tighten screws A.

### REMOVING AND REPLACING BOTTOM COVER

If your machine is a portable, remove the carrying case base as instructed below.

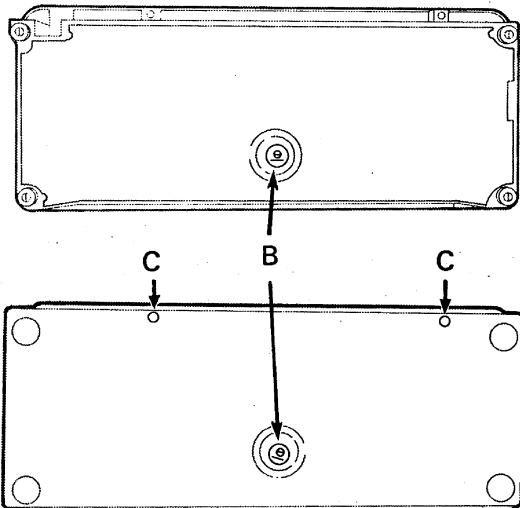

- To remove, tilt machine back and remove retaining nut B, being careful not to lose felt washer, and remove cover from underside of machine.
- To replace, position cover over bottom of machine and replace felt washer and retaining nut. Tighten retaining nut with a screwdriver.

### REMOVING AND REPLACING CARRYING CASE BASE

- Turn machine so that back is toward you. Tilt machine back and loosen and remove the two screws C at the back of base, and remove the retaining nut B from the center.
- Set machine upright and lift up and out of base.
- Replace machine in base, after bottom cover has been attached.
- Turn machine so that back is toward you; tilt back and replace screws and retaining nut. Tighten screws and retaining nut with a screwdriver.

### REMOVING AND REPLACING FACE PLATE

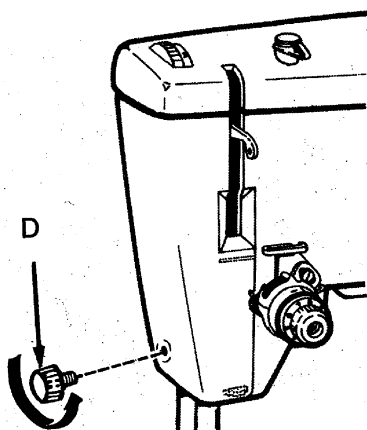

- Loosen and remove screw D and remove face plate by sliding it downward.
- Replace face plate by sliding top edge of plate under edge of arm top cover.
- Align screw hole in plate with screw hole in machine and replace and tighten thumb screw D.



## REMOVING AND REPLACING BOBBIN CASE

- Raise the presser foot.
- Turn hand wheel toward you until needle is above presser foot.
- Open slide plate. Draw plate toward you, opening it *all the way* to raise the throat plate locking pin.
- Remove throat plate.
- Remove bobbin.

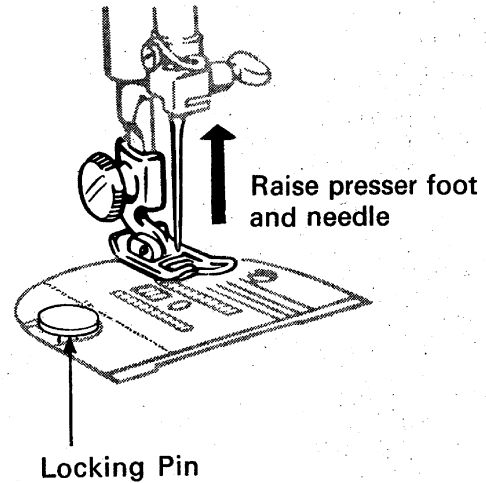

*To remove bobbin case, insert a screwdriver into screw slot of bobbin case holder and turn holder to back as far as it will go. Lift out bobbin case.*

*To replace bobbin case, guide the forked end under the feed dog and then draw the bobbin case under the position plate as illustrated. Turn holder all the way forward to lock bobbin case in position. After locking the bobbin case in position, check that the bobbin case does not bind but has slight rotational movement.*

- Replace throat plate.
- Close slide plate to lower throat plate locking pin and secure throat plate.

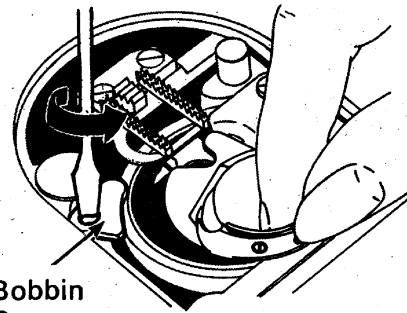

Bobbin Case Holder

**Push Holder Back and Lift out Case**

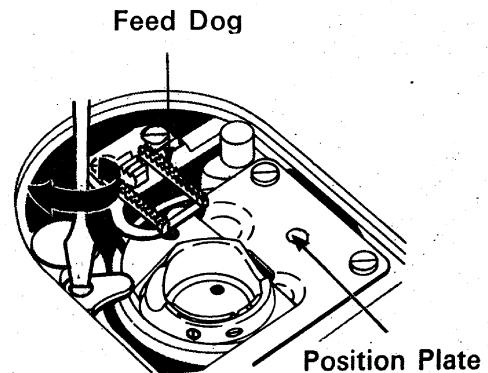

**Lock Bobbin Case into Position**

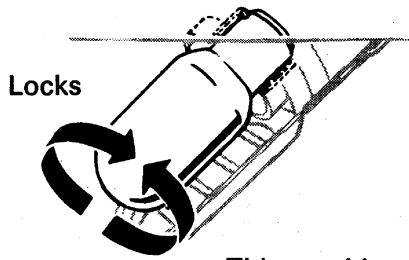

Locks

Unlocks

This machine is designed to use a 15 watt maximum light bulb.

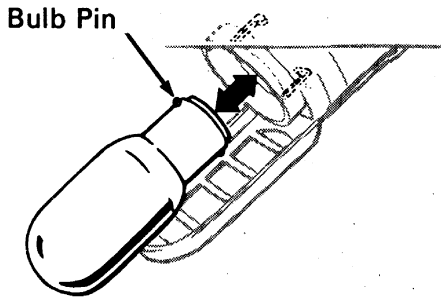

Bulb Pin

### Changing the Light Bulb

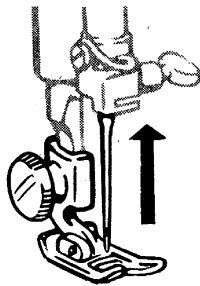

Raise Presser Foot and Needle

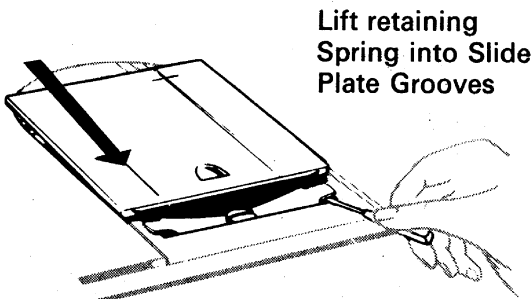

Lift retaining Spring into Slide Plate Grooves

### Replacing the Slide Plate

## CHANGING THE LIGHT BULB

Disconnect power-line plug from electrical supply.

### Removing the Bulb

With thumb and forefinger lower the light bracket. Do not attempt to unscrew bulb. Press it up into socket and at same time turn bulb over in direction shown to unlock bulb pin.

### Replacing the Bulb

Press new bulb into socket, with bulb pin entering slot of socket, and turn it over in direction shown to lock bulb in position. Release bracket, and entire assembly will snap back into recess.

## REPLACING THE SLIDE PLATE

You will not have any occasion to remove the slide plate. However, if it should accidentally become disengaged from the machine, it is easily replaced.

- Raise presser foot and needle.
- Place slide plate in slideway with the front edge close to, but not covering, the retaining spring (as shown in illustration).
- With a screwdriver, lift each end of the spring into each of the side grooves on the underside of the slide plate.
- Draw the plate gently toward you and fully engage the spring.
- Close slide plate.

## *performance checklist*

### **REMEMBER TO**

- Turn on power and light switch.
- Turn hand wheel toward you to position needle and take-up lever.
- Raise needle above fabric before making adjustments to stitch width, needle position and pattern selector.
- Use red selector settings for *Flexi-Stitch* pattern sewing.
- Start and finish sewing with the take-up lever in its highest position.
- Adjust stitch length, pressure, and thread tension to suit your fabric.
- Test-stitch on a fabric sample before starting a sewing job.
- Replace bent or burred needles.
- Lower presser foot before setting pressure dial.
- Tighten hand wheel knob and move bobbin winder switch to OFF after winding a bobbin.
- Remove feed-cover throat plate after button sewing and after darning with an embroidery hoop.
- Sew at a moderate speed when using a *Flexi-Stitch* pattern.

### **IF THREAD BREAKS, MAKE SURE**

- Machine is correctly threaded.
- Bobbin case is correctly inserted and threaded.
- Bobbin case area is free of lint and loose thread ends.
- Needle is straight and securely tightened in clamp.
- Thread is suitable for size of needle.
- Thread is free of slubs and knots.
- Needle-thread tension is light enough.
- Throat plate needle hole and presser foot are undamaged.
- Bobbin and bobbin case are undamaged.

*Enjoy Sewing!*

If you have any questions, please write to:

**Department of Sewing Education  
The Singer Company  
30 Rockefeller Plaza, New York, N.Y. 10020**

## FASHION AIDS

### *special accessories for special jobs*

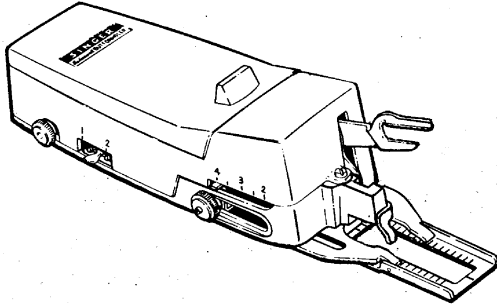

**Professional Buttonholer**

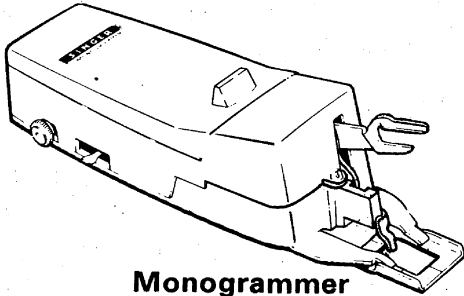

**Monogrammer**

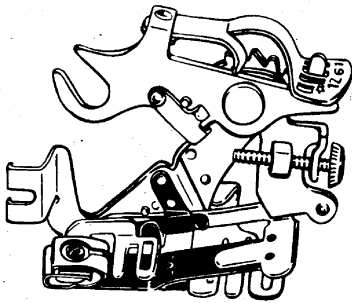

**Ruffler**

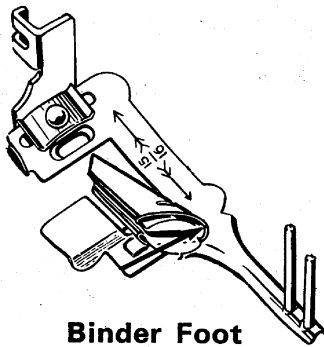

**Binder Foot**

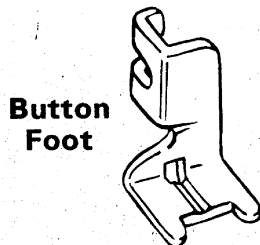

**Button Foot**

*Fashion aids* have been designed to increase the versatility of your sewing machine and enable you to give your sewing that extra professional touch. The ones described on this and the following page are just a few of the complete selection available at your local Singer Sewing Center.

**Professional \* Buttonholer No. 102575** sews six kinds of buttonholes, plus eyelets, in a wide variety of fabrics.

**Monogrammer No. 171269** makes  $\frac{3}{8}$ -inch-high initials to form monograms or names that add a charming individual touch to handkerchiefs, blouse collars, ties, etc.

**Ruffler No. 86742** offers a simple, effective way to make gathered and pleated ruffles. The ruffler is used for straight stitching only.

**Binder Foot No. 81245** is used to apply ready-made bias tape or unfolded bias binding to an unfinished fabric edge. It is particularly useful for binding seam edges that might ravel.

**Button Foot No. 161613** holds any two-hole or four-hole button securely for stitching. The groove in the foot can be used to hold a needle, over which a thread shank can be formed.

**Straight Stitch Foot No. 153267**  
**Straight Stitch Throat Plate No. 171391**

The straight stitch foot (snap-on type) and the straight stitch throat plate are especially useful when your fabric or sewing procedure requires close control, as when precision stitching of curved and scalloped edges, topstitching, edge stitching, etc.

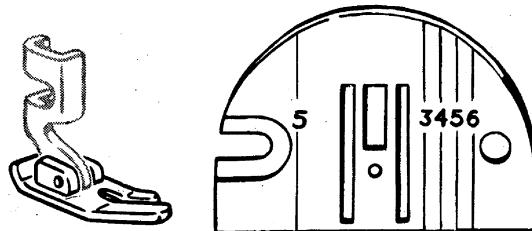

**Straight Stitch Foot**

**Straight Stitch Throat Plate**

**Quilting Foot No. 35932** is especially well adapted to stitching lightly padded fabrics. It is excellent for placement of straight stitching in block, floral, or scroll designs. This short, open foot permits following curved lines with ease and accuracy.

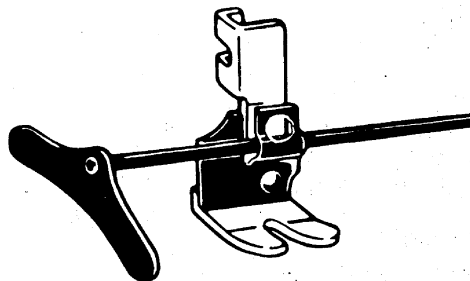

**Quilting Foot**

**Hemmer Foot No. 161671** is used for turning and stitching narrow hems in one operation. Thus, you can eliminate basting or pinning whenever you are making ruffle edges, lingerie finishes, and the like.

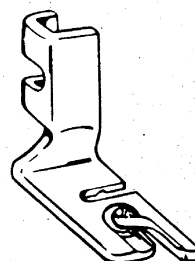

**Hemmer Foot**

**Edgestitcher No. 36865**, used with the straight stitch setting, is ideal for joining and inserting lace, tucking from pin width up to  $\frac{1}{4}$  inch, French seaming and seam piping, facing, and seam finishing.

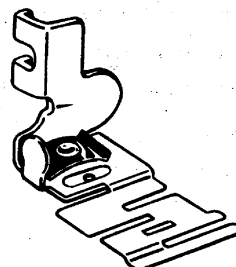

**Edgestitcher**

**Seam Guide No. 161172** helps keep seam width uniform when extra control is needed, especially on unusually wide or narrow seams. Used as a guide for topstitching and blindstitch hemming.

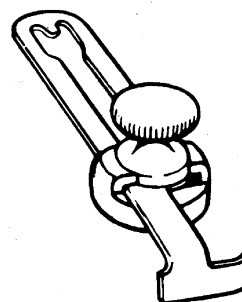

**Seam Guide**

## INDEX

	Page		Page
Accessories .....	6	Presser Foot .....	3, 6, 7
Applique .....	47	Changing .....	7
Blindstitch Hems .....	45	Presser Foot Lifter .....	3
Bobbin .....	5, 8, 11	Pressure Adjustment .....	18
Winding .....	11	Pressure Regulating Dial .....	3, 18
Bobbin Case		Principal Parts .....	2
Removing and Replacing .....	55	Reverse Stitching .....	17
Threading .....	13	Satin Stitching .....	26
Buttonholes .....	33	Seams, Sewing .....	20
Buttons .....	32	Corded .....	43
Carrying Case Base		Finishes .....	40
Removing and Replacing .....	54	Ladder .....	39
Checklist .....	57	Lingerie .....	40
Cleaning .....	53	Overedged .....	38
Darning .....	51	Straight .....	20
Darts .....	46	Shell Edging .....	48
Elastic, Attaching .....	38	Slide Plate .....	3, 56
Electrical Speed Controller .....	5, 9	Special Fabrics, Sewing .....	41
Embroidering .....	52	Special Purpose Foot .....	6, 25, 26, 47
Fabric, Thread and Needle Table..	10	Spool Pin .....	3
Face Plate		Stitch Length .....	4, 17, 25, 26, 29
Removing and Replacing .....	54	Stitch Pattern Selector .....	4
<i>Fashion Aids</i> .....	58	Setting .....	23, 27
Feed Cover Throat Plate.....	7	Stitch Width Selector .....	4, 16, 24, 28
Feed .....	3	Straight Stitching .....	16
Finishes for Hems and Facings....	39	Adjusting Selectors .....	17
<i>Flexi-Stitch</i> Pattern Dial..	3, 16, 23, 27, 29	Stretch Fabrics, Sewing .....	36
Free Motion Stitching.....	52	Take-up Lever .....	3
General Purpose Foot.....	6	Tension Adjusting .....	3
Guiding and Supporting Fabric....	22, 37	For Straight Stitching .....	19
Hand Wheel .....	3	For Zig-Zag Stitching .....	24, 26, 28
Hand Wheel Knob .....	5	Thread .....	10
Hems, Blindstitch .....	45	Thread Cutter .....	3
Knit Fabrics, Sewing .....	36	Threading the Machine .....	11, 31
Light Bulb .....	56	Throat Plate .....	3, 6, 7
Lubrication .....	53	Changing .....	7
Mending .....	49	Topstitching .....	46
Needle .....	8	Twin Needle .....	8
Changing .....	8	Twin-Needle Stitching .....	30
Threading .....	14	Zig-Zag Stitching .....	23
Twin Needle .....	8, 30	Needle Position .....	24, 28
Needle Clamp .....	3, 8	General Purpose Foot .....	6
Needle Position Selector .....	4, 24, 28	Satin Stitching .....	26
Oiling .....	53	Stitch Pattern Selector .....	23, 27
Pin Basting .....	20	Stitch Length .....	25, 26, 29
Power and Light Switch.....	4	Stitch Width .....	24, 28
		Zipper Foot .....	6, 43
		Zippers .....	43
		Blindstitch .....	44
		Straight Stitch .....	43

***SINGER***  
G U A R A N T E E

WE GUARANTEE that each SINGER\* sewing machine has been carefully manufactured and is in perfect operating condition on delivery. When subject to normal family use and care, any parts requiring replacement at any time owing to defects in material or workmanship will be replaced without charge.

THIS GUARANTEE does not apply to parts requiring replacement owing to natural wear or to abuse or negligence of the user or in the event the machine is serviced by other than a SINGER representative or Approved Dealer or with parts other than those supplied by The Singer Company.

IN ADDITION to the above guarantee of parts, each machine will be inspected and adjusted whenever necessary without charge for labor for a period of one year from date of purchase.

THIS GUARANTEE is effective only with respect to the person making the purchase from The Singer Company or one of its Approved Dealers. The original Sales Agreement, or Cash Receipt, must be presented to obtain the benefits of the guarantee.

AGREEMENTS inconsistent with the foregoing shall be void and of no effect.

THE SINGER COMPANY

# Let SINGER help you enjoy sewing...

with these products  
that make sewing easy!

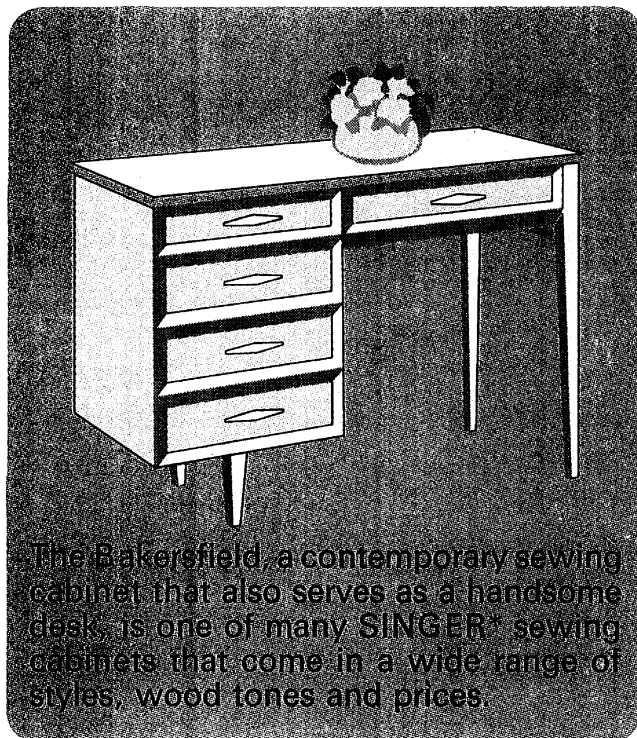

The Bakerfield, a contemporary sewing cabinet that also serves as a handsome desk, is one of many SINGER® sewing cabinets that come in a wide range of styles, wood tones and prices.

Fabrics for any season or occasion, for the fashion-conscious and the penny-conscious woman, for the home or wardrobe, are available at most Singer Sewing Centers. And color-coordinated notions and trims are there, too, along with helpful, friendly sewing advice.

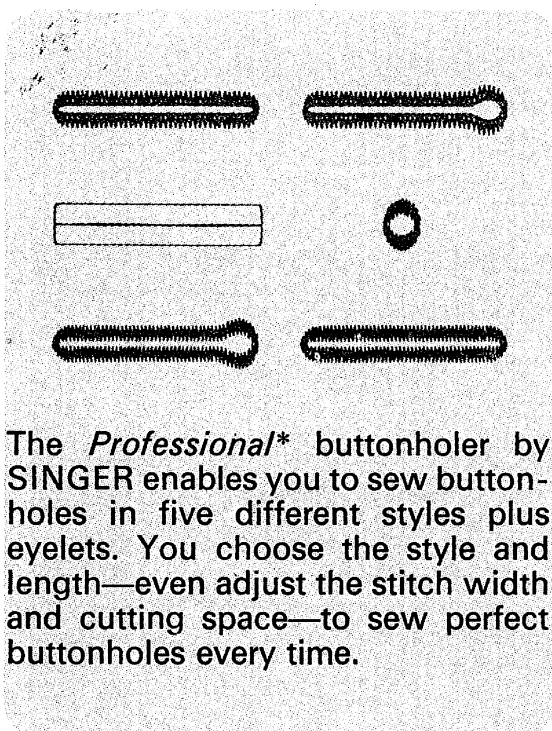

The *Professional*\* buttonholer by SINGER enables you to sew buttonholes in five different styles plus eyelets. You choose the style and length—even adjust the stitch width and cutting space—to sew perfect buttonholes every time.

