

Instructions for using

SINGER

Sewing Machine 206

THE SINGER MANUFACTURING COMPANY

SINGER*
ELECTRIC SEWING MACHINE
206K43

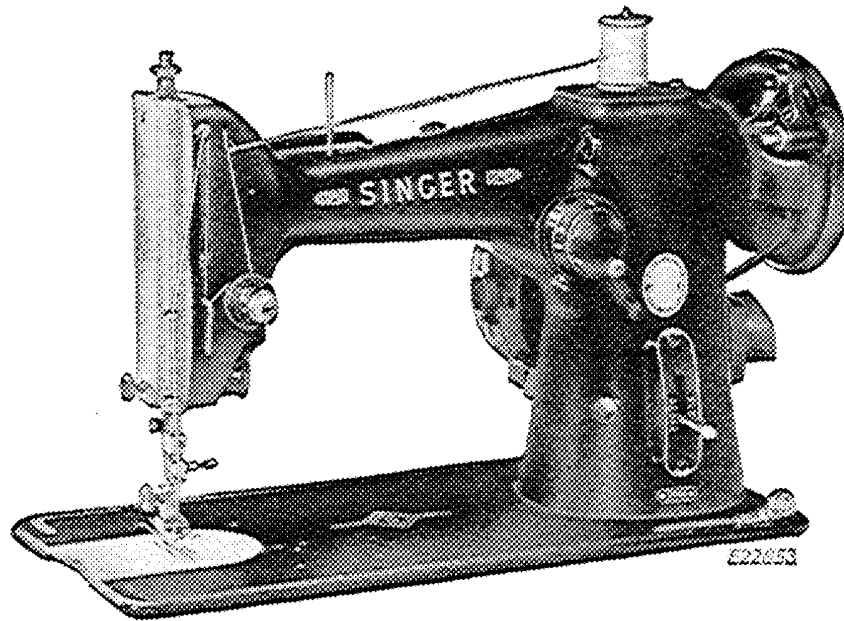

FOR
COMBINED
STRAIGHT
AND
ZIGZAG
LOCK STITCHING

THE SINGER MANUFACTURING COMPANY

*A Trade Mark of THE SINGER MANUFACTURING COMPANY

WHAT SINGER SERVICE MEANS TO YOU

Over 1400 SINGER SEWING CENTERS in the United States alone are fully equipped to serve women who sew.

There you'll find a wide selection of PATTERNS, BUTTONS, THREAD, and FINISHING SERVICES which include COVERING BUTTONS, MAKING BELTS AND BUCKLES, HEM-STITCHING, etc.

You are entitled to sewing lessons when you become the owner of a new SINGER. A skilled, SINGER-trained teacher personally guides you and assists you in learning the fundamentals of home sewing. Further courses embracing all phases of home sewing are available at low cost.

REPAIR SERVICE is as convenient as your telephone. Should your machine ever need adjustments, a trained, courteous SINGER representative will gladly call at your home. SINGER* Service assures excellent workmanship, guaranteed repairs, and SINGER* parts. A written estimate is given you in advance for approval.

And remember, your SINGER SEWING CENTER and the ever ready SINGER Service Car can be easily identified by the famous SINGER Red "S" Trade Mark.

AS THE OWNER OF THIS SINGER SEWING MACHINE:

You have a machine made with the same care and craftsmanship that have been the hallmark of SINGER Machines for more than a century. We are acutely aware that SINGER Sewing Machines have become an American tradition and are intensely proud of, and determined to continue, this heritage.

Your SINGER "206" is the product of this pride, and of the determination and the unsurpassed technical skill of SINGER. This smooth-running machine-of-today will amaze and thrill you with its versatility and ease of operation.

Utilize all the advanced features, combine them with your own skill and discover a new world of sewing enjoyment. Exclusive dresses for yourself, clothing for your family and a multitude of items for your home will be yours — all at a fraction of their ready-made cost.

ADVANCED FEATURES OF THE SINGER 206

- **MORE VERSATILE STITCHING** than ever before possible.
- **FAST, EFFICIENT, EVER-READY** for "on-the-spot" sewing, whether it be to mend a glove, sew on a button, make a dress or a trousseau, a buttonhole or a complete layette, a slip-cover or an embroidered guest towel, a snow-suit or a bridal veil.
- **FRONT THREADING NEEDLE** — visible eye is quickly threaded.
- **ROTARY MOVEMENT** — for smooth, quiet performance.
- **FULL VISION BOBBIN CASE** — facilitates removal and replacement.
- **EXTRA-CAPACITY, TIME SAVING BOBBIN.**
- **CALIBRATED TENSION** — for accurate adjustment to any type of fabric.
- **REVERSIBLE FEED** for sewing either in a forward or backward direction — easy to back tack and to fasten ends of seams.
- **CALIBRATED STITCH REGULATOR** — with finger-tip control.
- **SMOOTH, SEAMLESS THROAT PLATES** — clip on to insure snag-free performance.
- **POSITIVE FEED** — for handling all types of fabrics.
- **FEED THROW-OUT DEVICE** permits darning and embroidering without attachments.
- **EASY STARTING** — no coaxing necessary — lightly press the knee or foot control and your 206 starts to sew instantly.
- **PERFECT CONTROL** — whether high speed or stitch-by-stitch retarding is required, the "pick-up" and "stop" IS QUICK AND EFFORTLESS.
- **LIGHT** — illuminates working area — prevents eye-strain — lamp easily renewed.

ELECTRICAL INFORMATION

The SINGER Electric Motor*

is located at the back of the machine, and is regularly furnished for operation on an alternating current of 110-120 volts, 25-75 cycles, or on 110-120 volts direct current. Special motors can be furnished for direct or alternating current for any voltage between

50 and 250, and for 32 volts direct current.

Before Inserting Electric Plug —

be sure that voltage and number of cycles stamped on motor nameplate are within range marked on electric meter installed by electric power company.

Electrical Connections for Machine

Push 3-pin terminal plug **E**, **Fig. 1**, on 3-pin terminal block at right of machine and connect plug at other end of cord to electric outlet.

Speed Controller

The speed of machine is regulated by amount of pressure on foot controller or knee controller.

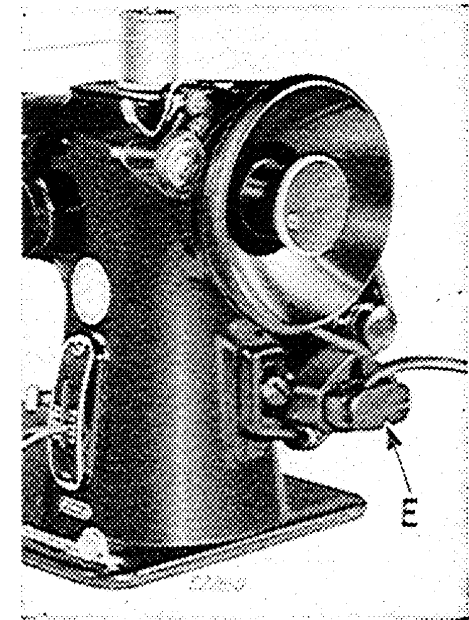

Fig. 1. Electrical Connection for Machine

SINGER* Light

To Turn Light "on" or "off"

Reach over machine arm and turn switch **A**, Fig. 2 to right.

To Remove the Bulb

Grasp light socket so that thumb extends over switch **A**. Then press shade with thumb at **B** to release shade from two catches and slide it halfway out of shade holder **D**. Then press bulb into socket and at same time turn bulb over from machine as far as it will go, then withdraw the bulb.

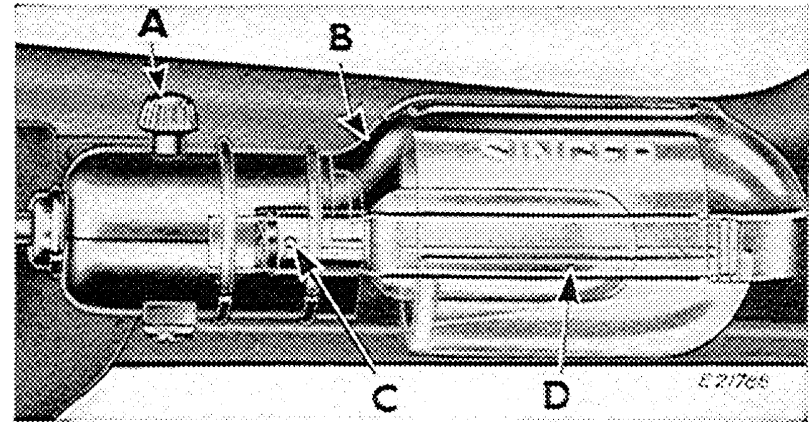

Fig. 2. Replacing the Bulb

To Insert a New Bulb

Press bulb into socket and turn it over toward machine until bulb pin **C** enters notch in socket, then return shade to its normal position, as shown in **Fig. 2**.

TO OIL THE MACHINE

Occasionally apply a drop of oil to all points indicated by the arrows in **Figs. 3, 4, 5, 6 and 7**, and carefully clean the machine to insure smooth and satisfactory performance.

Loosen screw **J**, **Fig. 4**, and swing plate aside for access to oiling points under plate.

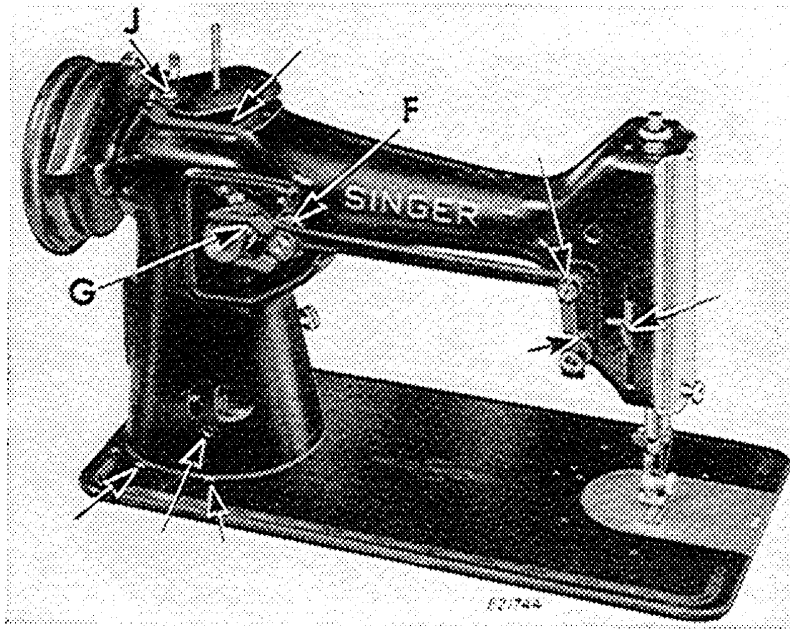

*Fig. 4. Rear View,
Showing Oiling Points*

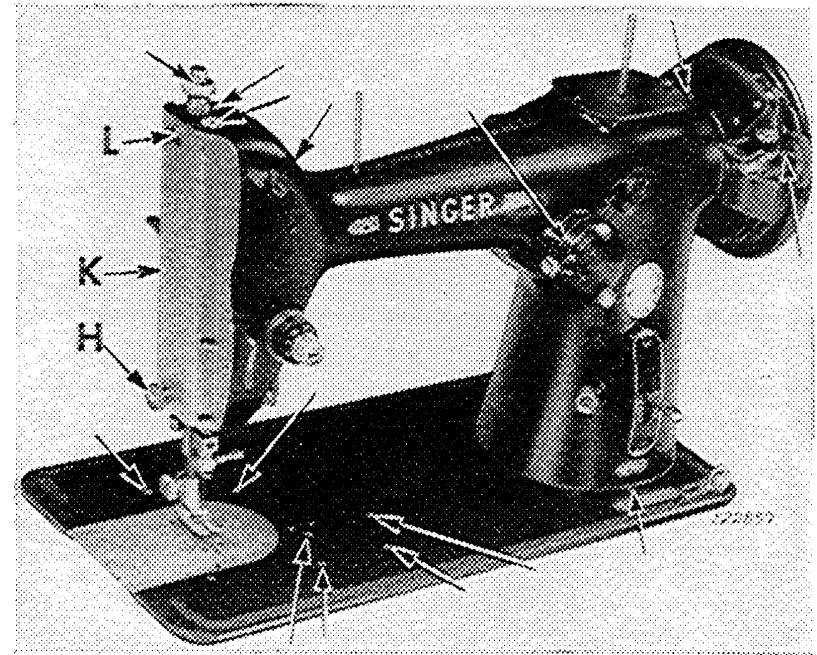
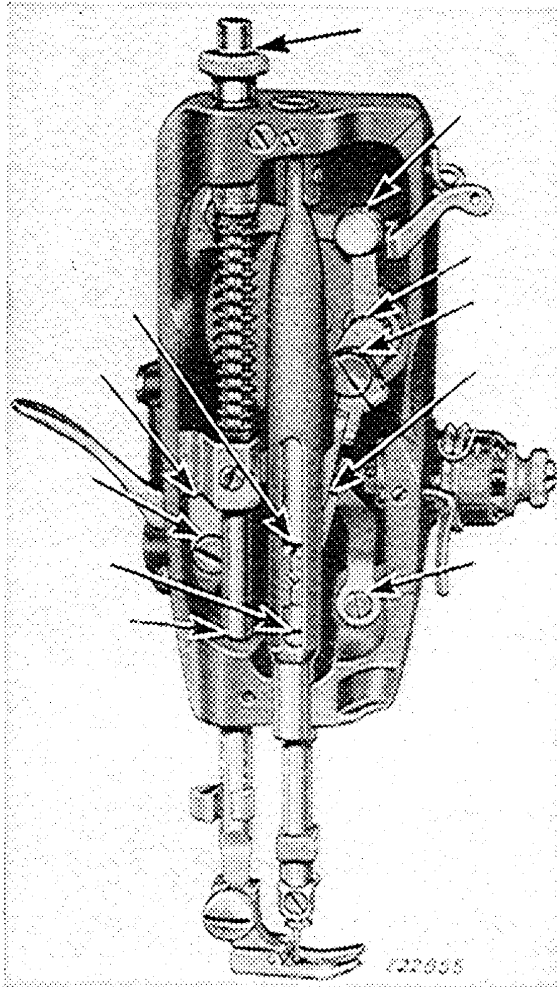

*Fig. 3. Front View,
Showing Oiling Points*

Loosen thumb screw on cover plate at back of arm and swing plate out of the way to oil the bight mechanism at **F** and **G**, **Fig. 4**.

NOTE: Motor and light have been removed in oiling illustrations for clearer views of parts, but need not be removed when actually oiling the machine.

Remove face plate **K**, **Fig. 3**, by taking out thumb screw **H** and loosening screw **L** near top of plate. Slip plate over screw **L**. Oil the points indicated in **Fig. 5** and then replace plate **K**, **Fig. 3**. Occasionally apply a drop of oil to race of bobbin case holder as shown in **Fig. 6**.



*Fig. 5. Face Plate Removed.
Showing Oiling Points*

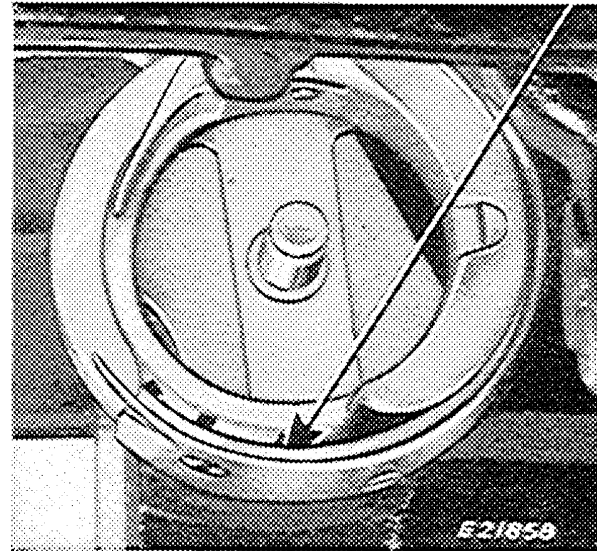

*Fig. 6. Oiling Point in Bobbin
Case Holder*

Turn the machine head back on its hinges and oil the places shown in Fig. 7.

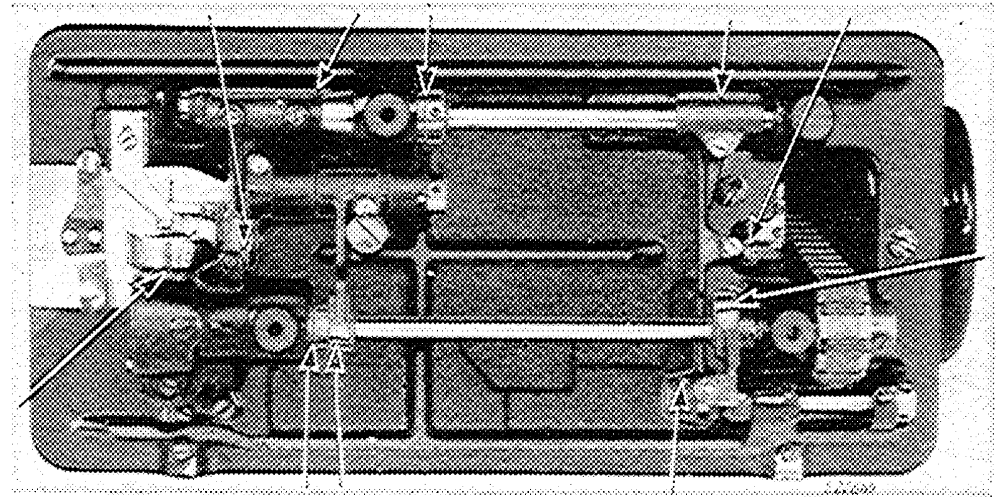

Fig. 7. Oiling Points in Base of Machine

TO LUBRICATE THE MOTOR

NEVER USE OIL OR ORDINARY GREASE ON THE MOTOR. USE ONLY **SINGER** MOTOR LUBRICANT furnished with the machine. When the machine is shipped from the factory, the two grease tubes **M**, Fig. 8, are filled with enough lubricant for approximately six months' use. Refill grease tubes **M** at least once each six months by inserting tip of lubricant container into grease tubes **M** and squeezing enough lubricant into each tube to fill it.

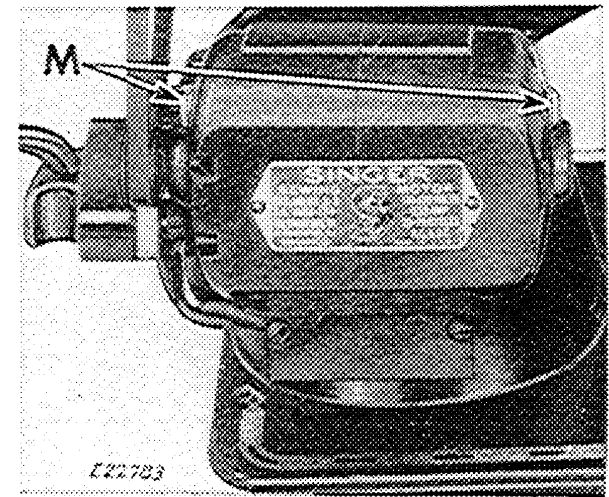

Fig. 8. Motor Lubricating Points

CHART SHOWING RELATIONSHIP OF TYPES OF FABRICS, THREAD AND NEEDLE SIZES AND MACHINE STITCHES TO THE INCH

TYPES OF FABRICS	THREAD SIZES	NEEDLE SIZES	MACHINE STITCHES PER INCH	
			INSIDE SEAMS	TOP STITCHING
Filmy materials comparable to Net, Marquisette, Chiffon, Silk and Chiffon Velvets, Voiles, Ninon	Mercerized 00 100 Cotton 00 and 000 Silk Nylon Thread	9	15 to 20	15 to 20
Sheer materials comparable to Lawn, Dimity, Synthetic Sheers, Paper Taffetas, Pure Silks, Gossamer Silks, Silk or Synthetic Tricots, Synthetic Velvets, Satins	Mercerized 0 80 to 100 Cotton 0 Silk Nylon Thread	11	12 to 15	15 to 20
Lightweight materials comparable to Gingham, Chambray, Pique, Poplin, Percale, Cretonne, Chintz, Faille, Bengaline, Wool Flannel, Wool Jersey, Wool Crepe, Cotton Velvets and Velveteens, Lightweight Suitings	Mercerized A 60 to 80 Cotton A Silk	14	12	15 to 18
Medium heavy materials comparable to Corduroy, Crash, Gabardine, Rep, Heavy Suitings and Coatings	Heavy Duty Mer. 40 to 60 Cotton Nylon or Dacron Thread	16	10	12
Heavy materials comparable to Sailcloth, Denim, Ticking, Overcoatings	30 to 40 Cotton Dacron Thread	18	8	10
Plastic materials	Mercerized Thread 0 to A	9 or 11	10	12

When ordering needles, always specify "Class and Variety 206 x 13" and state the size and quantity required.

NEEDLES AND THREAD

For perfect stitching, thread should be selected according to fabric to be stitched and needle must be correct size for thread which must pass freely through eye of needle.

TO SET THE NEEDLE

Select correct needle according to table on **page 10**. Be sure that needle is not blunt or bent. Raise the needle bar to its highest position and loosen thumb screw **N**, **Fig. 9**, in the needle clamp. Insert needle into clamp as far as it will go, with **flat side to the back** and **long groove toward you**. Then tighten thumb screw **N**.

206 x 13 NEEDLE

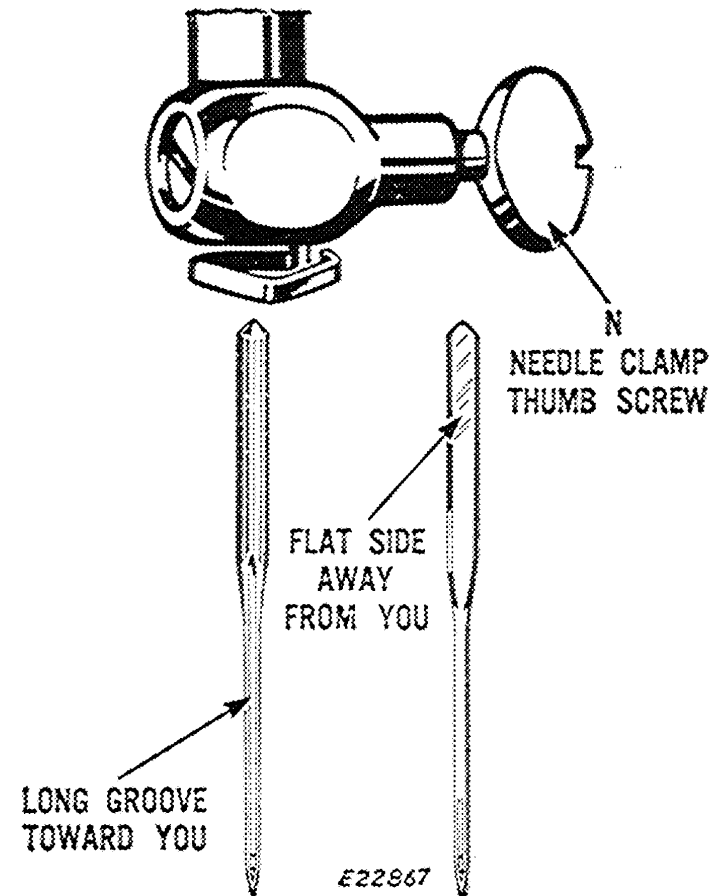

Fig. 9. Setting Needle in Needle Clamp

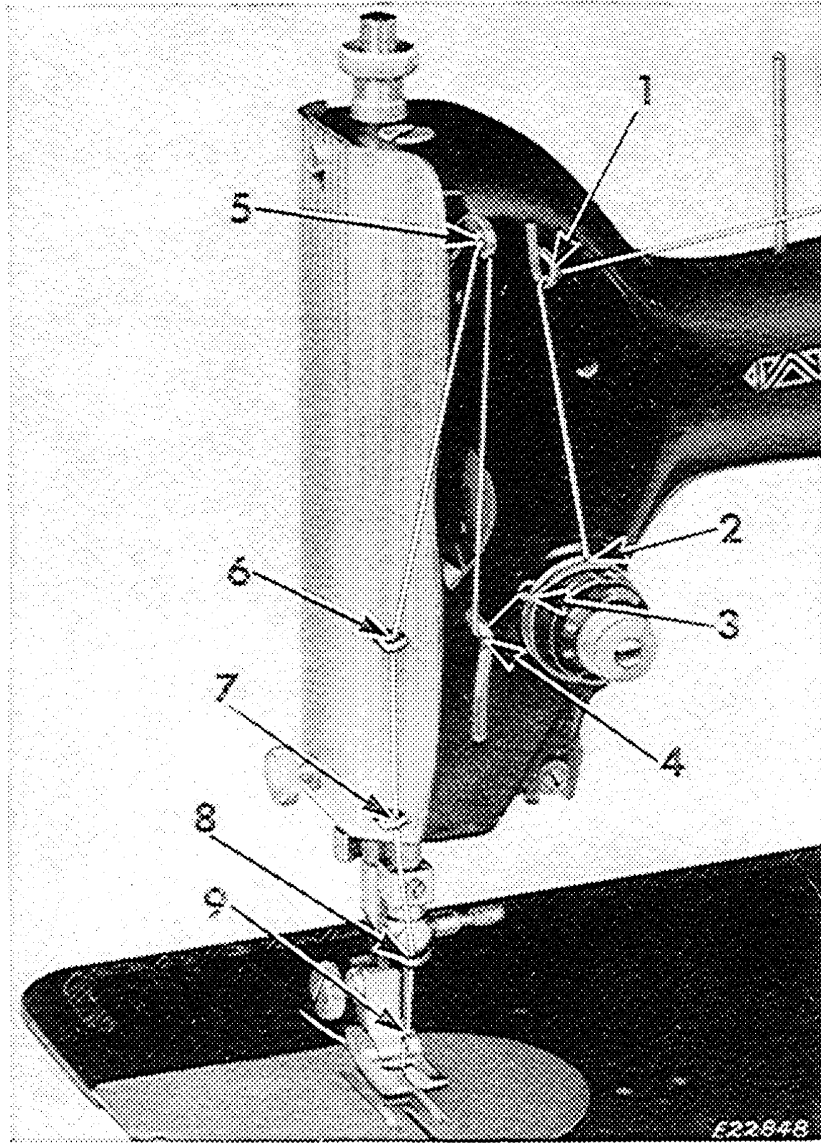

Fig. 10. Upper Threading

UPPER THREADING

See Figs. 10 and 11

Raise take-up lever 5 to its highest point.

Place spool of thread on spool pin

Lead thread into thread guide 1

Down and from right to left between tension discs 2

Into the loop of the take-up spring 3

Under the slack thread regulator 4

Up and from right to left through hole in take-up lever 5

Down through guides 6 and 7 on face plate

Into guide 8 on needle clamp

From **front to back** through eye of needle 9.

Draw about two inches of thread through eye of needle

with which to commence sewing.

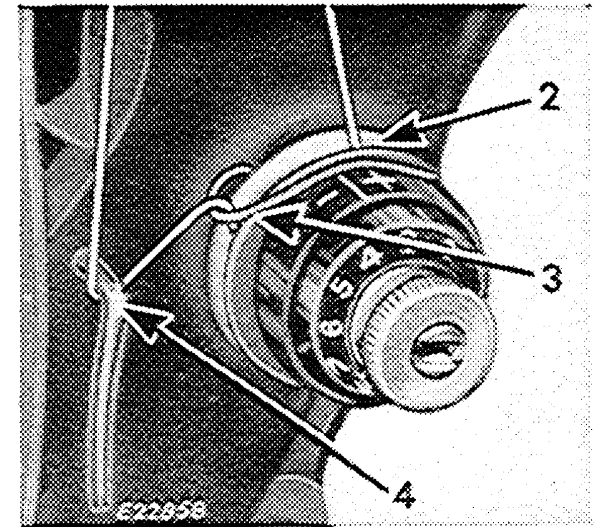

*Fig. 11. Upper Threading
around Tension*

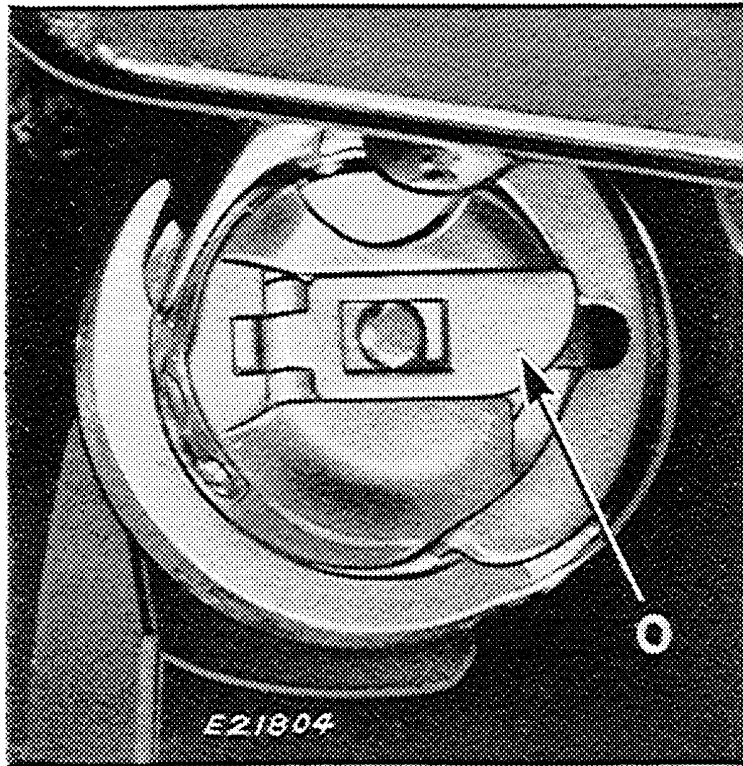

*Fig. 12. Removing
Bobbin Case*

TO REMOVE THE BOBBIN

Raise needle to its highest point. Tilt machine back on its hinges. Open latch **O**, Fig. 12 and lift out bobbin case. Release latch and remove bobbin.

TO WIND THE BOBBIN

See Fig. 13

Hold hand wheel **P** with left hand and, with right hand, loosen stop motion screw **Q** to release hand wheel from stitching mechanism. Place spool of thread on spool pin **1**. Draw thread through guide **2**, Fig. 13 on arm of machine and pass thread down and from left to right under tension **3**. Pass thread up and, from inside, through slot in left side of bobbin **4** and press bobbin on to winder spindle until spindle pin enters slot in right side of bobbin. Press bobbin winder against hand wheel until latch **T** engages.

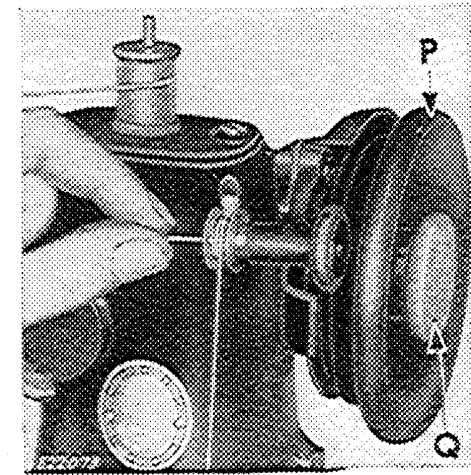
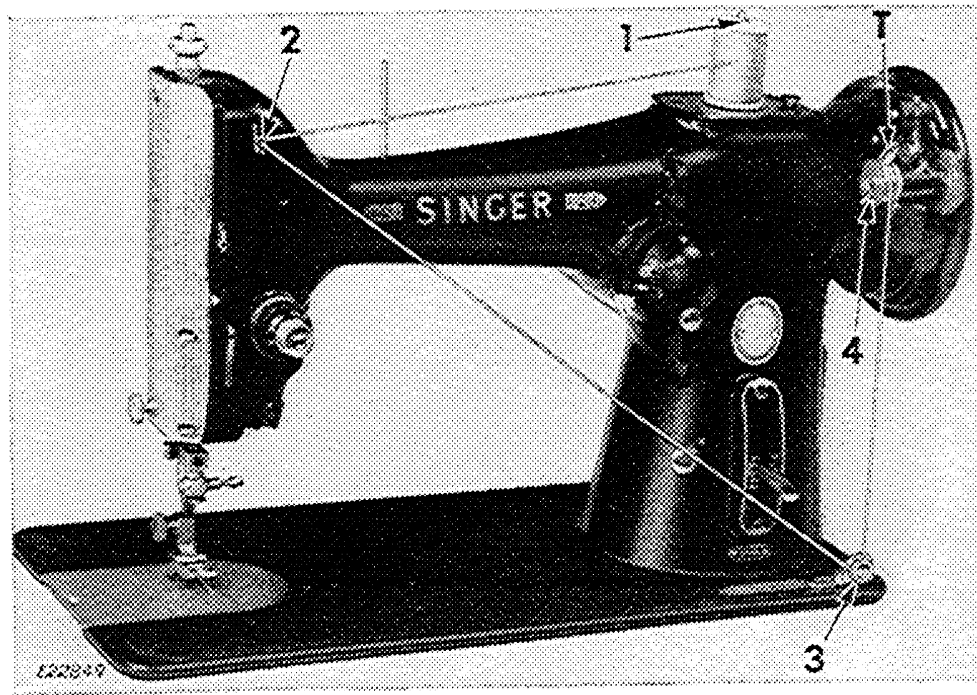

Fig. 13. Winding the Bobbin

Holding free end of thread as shown in **Fig. 13**, press controller as for sewing. After a few coils have been wound around bobbin, break off end of thread. The bobbin winder

will stop automatically when sufficient thread is wound on bobbin. Remove bobbin from bobbin winder spindle and re-tighten stop motion screw **Q**, **Fig. 13**.

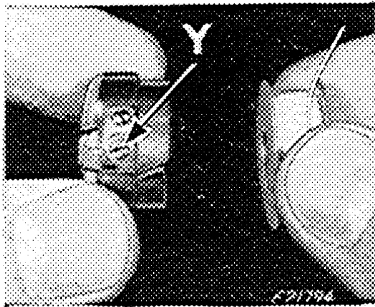

Fig. 14

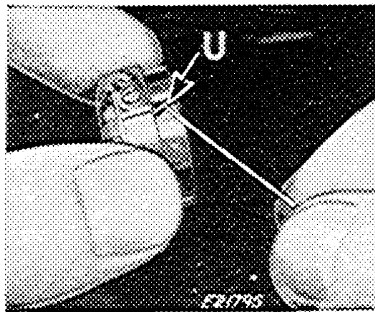

Fig. 15

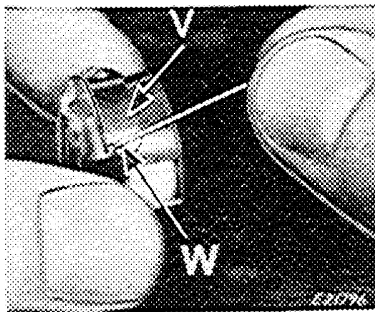

Fig. 16

TO THREAD BOBBIN CASE

Hold bobbin so that thread will unwind in direction shown in Fig. 14. Hold bobbin case as shown in Fig. 14, and place bobbin into it.

Pull thread into slot U, Fig. 15 under tension spring V, Fig. 16 and into slot W at end of spring. Allow about three inches of thread to hang free from bobbin case.

TO REPLACE BOBBIN CASE

Hold bobbin case by latch and replace it on stud X, Fig. 17, having thread draw from top of bobbin case. Release latch and press bobbin case back until latch catches groove near end of stud. Allow about three inches of thread to hang free from bobbin case.

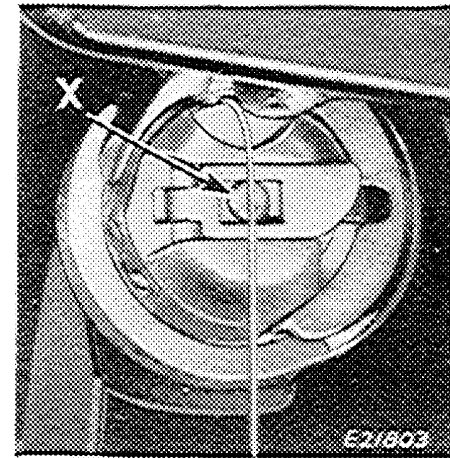
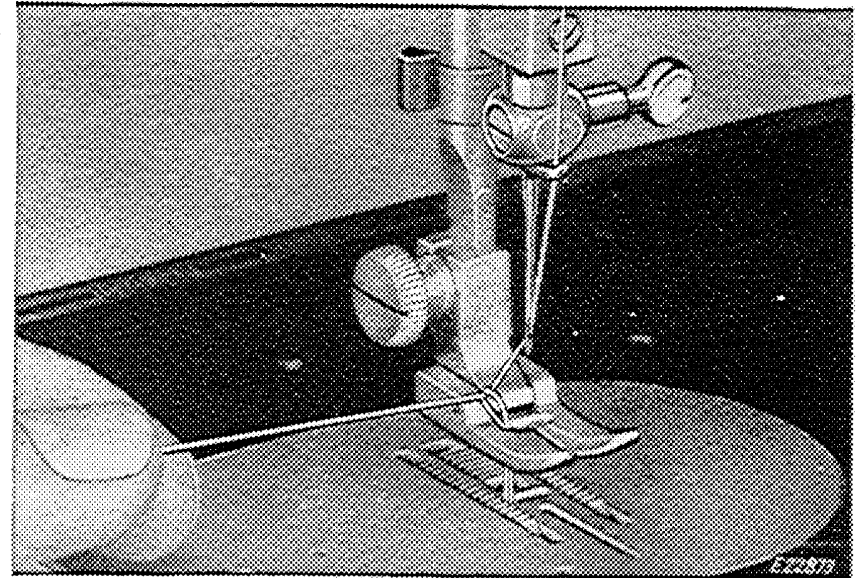

Fig. 17. Bobbin Case Threaded and Replaced

TO PREPARE FOR SEWING

Hold end of needle thread with left hand and turn hand wheel over toward you until needle goes down and up again and thread take-up lever **5, Fig. 10** is at its highest point. Pull up needle thread and bobbin thread will come with it, as shown in **Fig. 18**. Lay both threads straight back under presser foot as shown in **Fig. 19**, place needle in position, and lower the presser foot.



*Fig. 18. Drawing Up
Bobbin Thread*

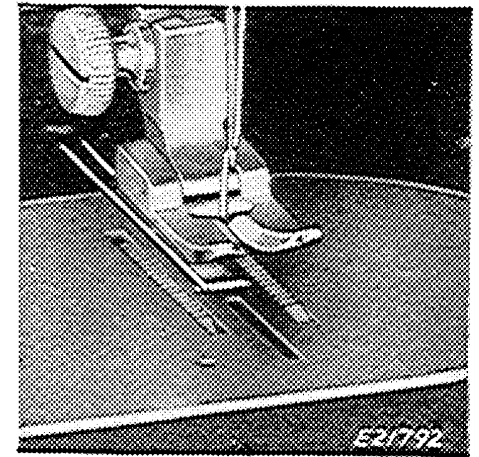

*Fig. 19. Threads in Position
to Commence Sewing*



*Fig. 20. Correct Position
at Machine*

OPERATING

Press controller to start machine. The speed depends upon amount of pressure you apply to controller. Start slowly, maintain an even speed, and stop gradually. Never pull material along when stitching. Guide material lightly.

Never operate machine without cloth under presser foot.

TO REMOVE THE WORK

Stop machine with thread take-up lever **5**, **Fig. 10** at its highest point. Raise presser foot by means of presser bar lifter, draw fabric back and to left and sever threads on thread cutter. Place ends of threads straight back under presser foot, as shown in **Fig. 19**.

IMPORTANT

This SINGER Class 206 Machine is equipped with an **All-purpose Throat Plate 105053** (see **page 22**), having a wide throat, to accommodate the swing of the needle when zig-zagging and for **all** types of stitching.

The **All-purpose Hinged Presser Foot 105069** (see **page 22**) is mated to the **All-purpose Throat Plate**, having the same wide opening to accommodate the swing of the needle.

With this equipment the machine can perform:

Straight Stitching
Zigzag Stitching
Ornamental Stitching

For extra convenience, especially when the fabric being sewn is particularly soft, or open meshed, **Straight Stitching Throat Plate 105055** (see **page 20**) with its mated **Straight Stitching Presser Foot 189647** (see **page 20**) is provided.

CAUTION: Straight stitching equipment cannot be used for zigzag stitching. It can be used **only** AFTER the Bight Lever, **B2, Fig. 21**, is set at **O** and the Needle Position Lever, **A2, Fig. 21**, is at its Central Position.

STRAIGHT STITCHING EQUIPMENT

All of the parts shown on this page and on page 21 are designed for straight stitching **only** and must not be used for zigzag stitching.

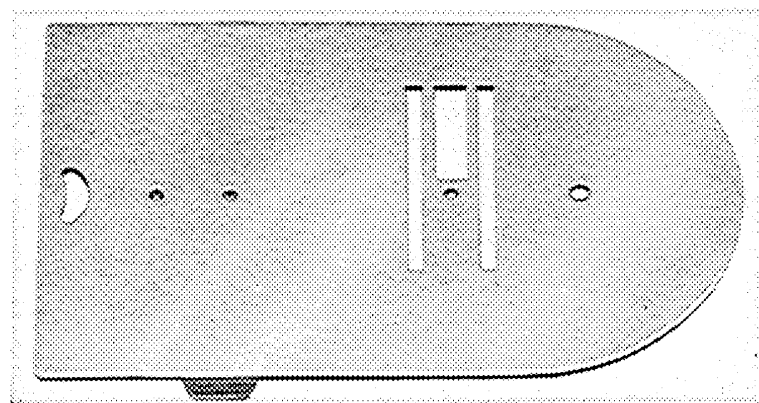

*105055 Straight Stitching
Throat Plate*

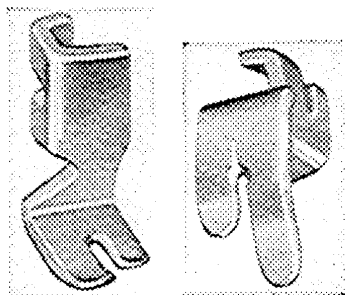

*189647 Straight Stitching
Presser Foot*

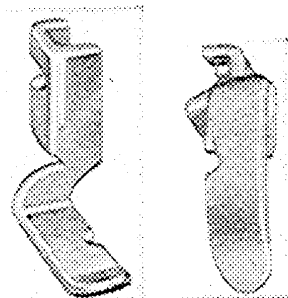

*160845 Cording Foot
(Left Toe)*

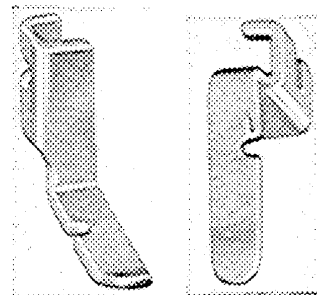

*160846 Cording Foot
(Right Toe)*

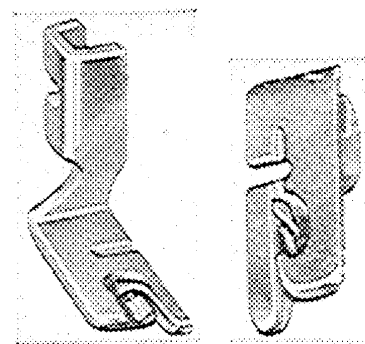

120342 Hemmer Foot

CAUTION: Equipment shown on this page and on page 20 can be used **only** AFTER Needle Position Lever **A2** is set at central position and Bight Lever **B2** is set at O, as shown in Fig. 21.

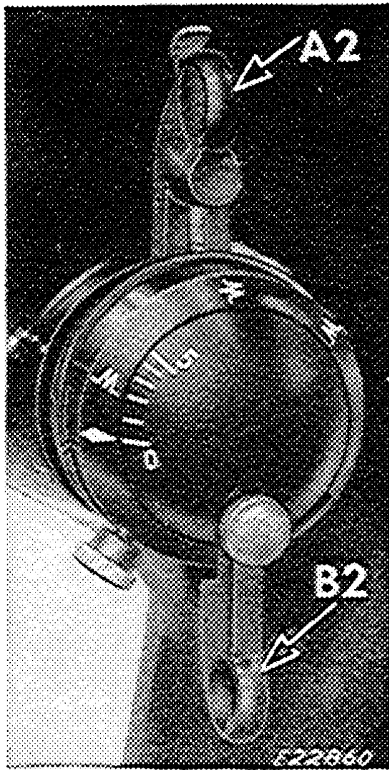

*Fig. 21. Machine Set For
Straight Stitching*

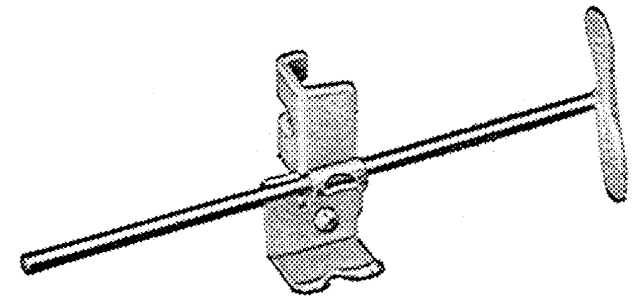

35932 Quilter

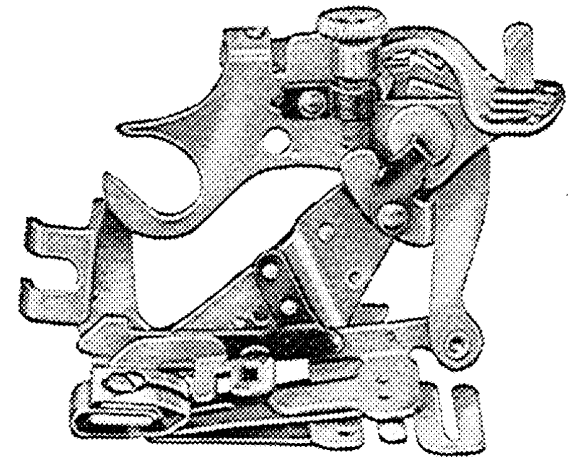

120598 Ruffler

ALL-PURPOSE STITCHING EQUIPMENT

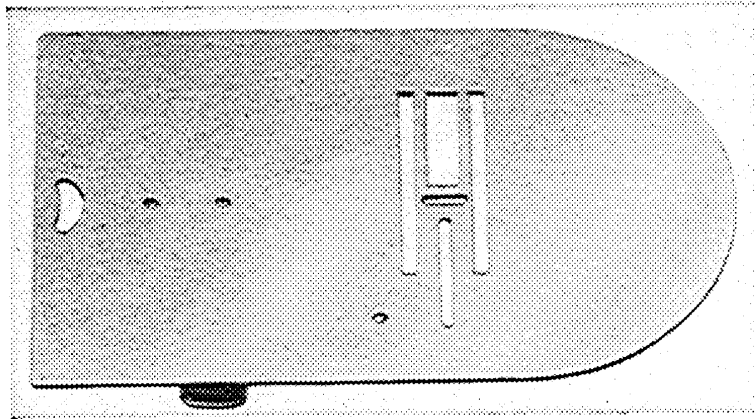

105053 All-Purpose Throat Plate

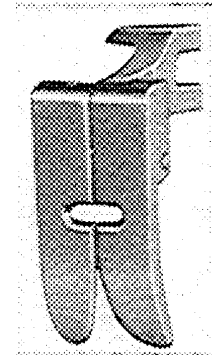
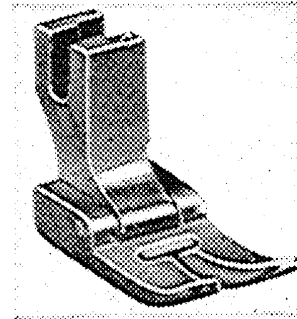

105069 All-Purpose Hinged Presser Foot

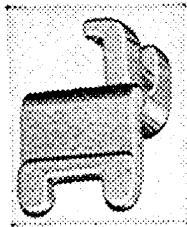
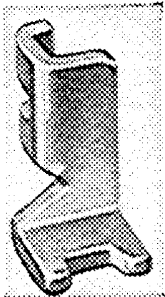

189648 Button-Sewing Foot

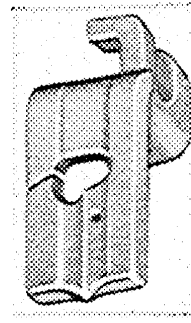
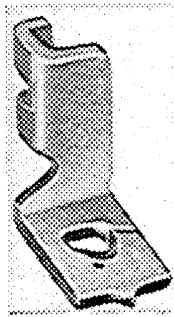

36616 Buttonholer Foot

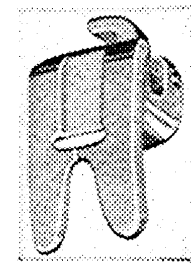
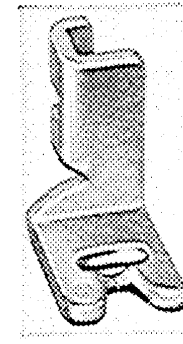

189649 Satin Stitch Foot

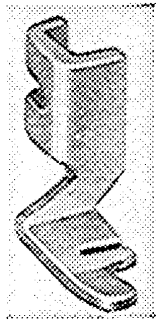

*189650 Cord-Covering
and Appliqué Foot*

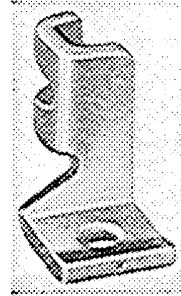
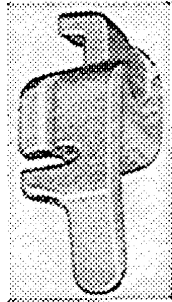

*189651 Embroidery
and Appliqué Foot*

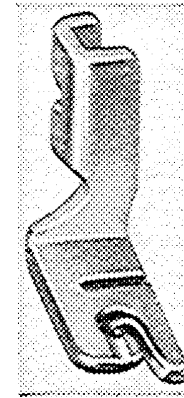
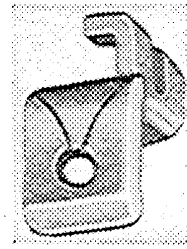

189653 Shell Hemmer

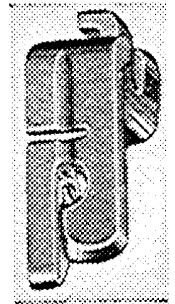

NOTE: With the equipment on this page and on page 22, the full range of stitching variations may be attained. The settings for these stitch variations are attainable by moving the Needle Position and Bight Levers **A2** and **B2** to any point required.

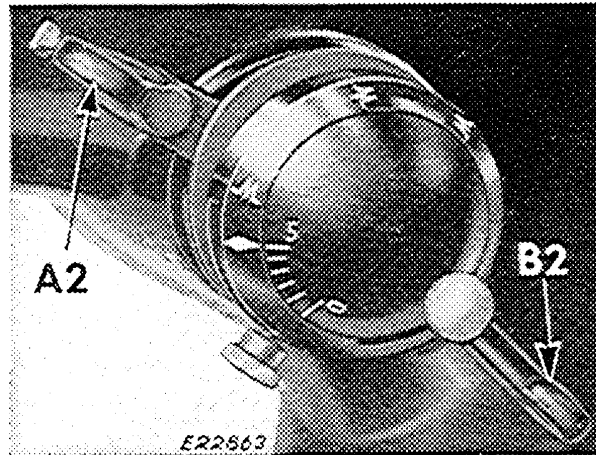

*Fig. 22. Machine Set For Maximum
Zigzag Stitch in Left Position*

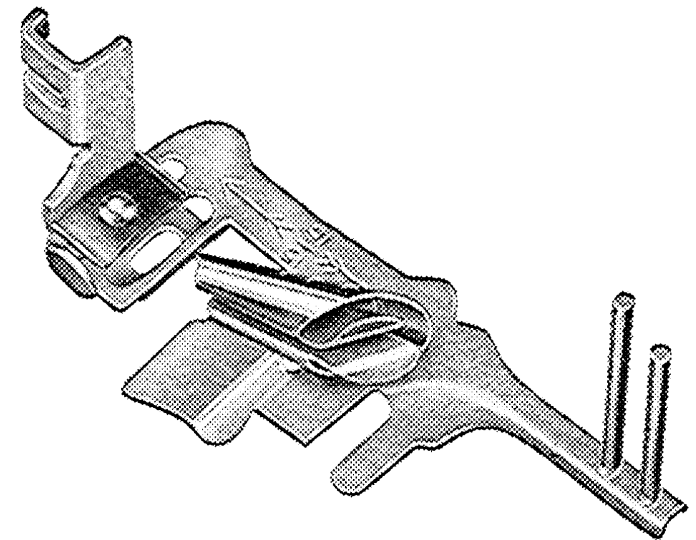

160347 Multi-slotted Binder

NEEDLE POSITION CONTROL

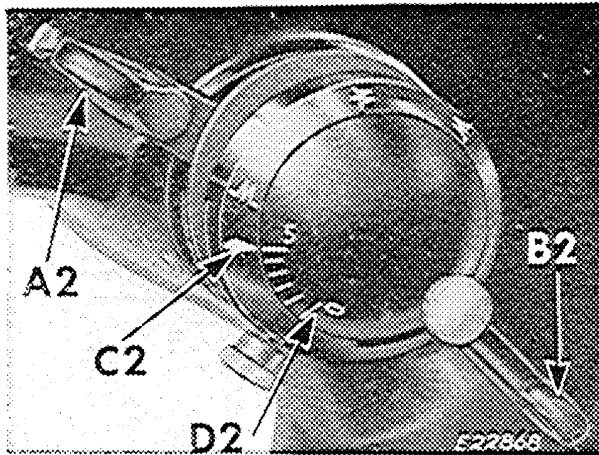

Fig. 23. Left
Needle Position

When Needle Position Lever **A2** is set to the **left** on the dial, as shown in **Fig. 23**, the needle swings from the **extreme left**, as shown in **Fig. 23A**. The **left needle position** is necessary when sewing on buttons, sewing and barring buttonholes, and for many of the ornamental stitches.

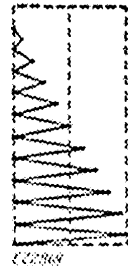

Fig. 23A

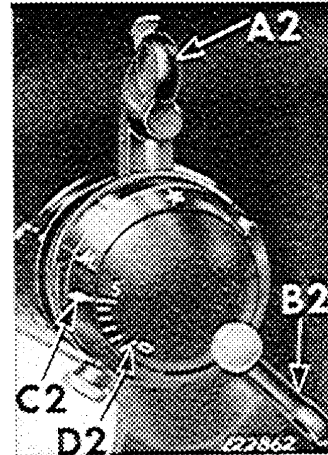

Fig. 24. Central
Needle Position

When Needle Position Lever **A2** is set at the **central** position, as shown in **Fig. 24**, the needle swings equally to the left and right of center, as shown in **Fig. 24A**.

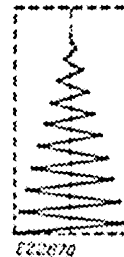

Fig. 24A

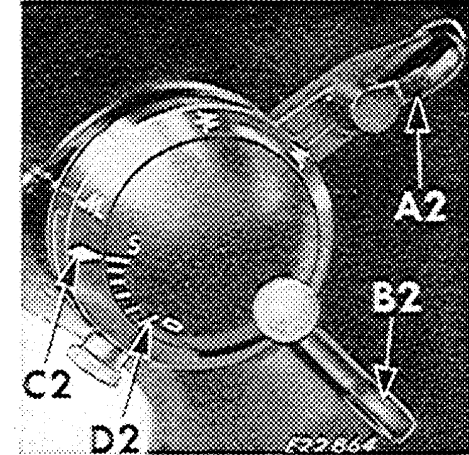

Fig. 25. Right
Needle Position

When Needle Position Lever **A2** is set to the **right** on the dial, as shown in **Fig. 25**, the needle swings from the **extreme right**, as shown in **Fig. 25A**.

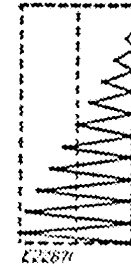

Fig. 25A

CAUTION: **Left Needle Position** and **Right Needle Position** are used **only** with the All-Purpose Throat Plate, for straight stitching as well as zigzag stitching.

BIGHT CONTROL

Straight stitching can be made in any of the three different needle positions described on Page 24 with **Bight Lever B2** set so that arrow **C2** points to "0" on the dial. For zigzag stitching, the amount of swing is controlled by Bight Lever **B2**. The Bight Control Dial **D2** is marked with numerals from "0 to 5" to indicate the swing of needle.

As Bight Lever **B2** is moved to right and Arrow **C2** points to 1, 2, 3, 4 or 5 on the dial, the swing of needle is increased from the smallest zigzag stitch at No. 1 up to maximum zigzag stitch (approximately 3/16 inch) at No. 5.

Both Bight Lever **B2** and Needle Position Lever **A2** can be moved while stitching for varied uses and effects.

Screw **F2** acts as a stop which limits maximum bight. Screw **E2** is notched to enable you to set a minimum bight position and to permit you to pass beyond it, if desired. These screws allow you to manually operate the bight lever between the set positions without continual reference to the dial while sewing. For example: To limit zigzag stitching between "1 and 4", set Bight Lever **B2** at "4", loosen screw **F2**, then tighten. To set minimum limiting position "1", set Bight Lever **B2** so that arrow **C2** is at "1", loosen screw **E2** and move it up or down until you feel the notch engaged, then tighten screw **E2**. The bight control is now set to limit the maximum bight at "4" and the minimum bight at "1" which can be felt and passed to zero if desired. Other limits such as "1 to 3" or "2 to 3" can be obtained in the same manner.

When bight limiting screws are not required, loosen screws **E2** and **F2**, set bight lever at "5" and tighten

CAUTION: When Straight Stitching Throat Plate 105 055 is used, Bight Lever **B2** must be set at 0, and needle must be set at Central Position.

Do not make any Zigzag stitch or needle position adjustments while needle is in goods when the machine is not in operation.

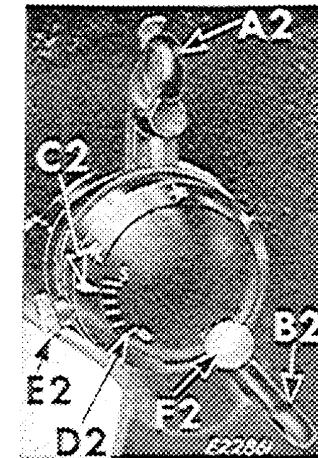

Fig. 26. Bight Limit Screws and Bight Control Dial

screw **F2**. For straight stitching, set bight lever at zero, move screw **E2** until notch is engaged and tighten.

When a definite bight is desired, screw **E2** must engage the notch at that bight and be tightened.

When free movement of the bight lever is desired between zero and maximum bight, screw **E2** should be moved down as far as it will go and then securely tightened.

TO REGULATE LENGTH OF STITCH

The length of stitch determines the space between the zigzag stitches. A long stitch setting spreads the zigzag and a short stitch setting brings the zigzag together. The machine is adjustable to make approximately from 6 to 30 straight stitches per inch. The numbers on the stitch regulator scale **J2**, Fig. 27, are relative, those on the right of the scale indicating the

position at which the stitch regulating lever **G2** should be set to produce the number of stitches indicated directly opposite on the left of the scale.

To regulate length of stitch, see that stitch regulator limit screw **H2** is turned outwardly as far as required to permit the stitch regulating lever **G2** to be set at the number indicating the desired length of stitch.

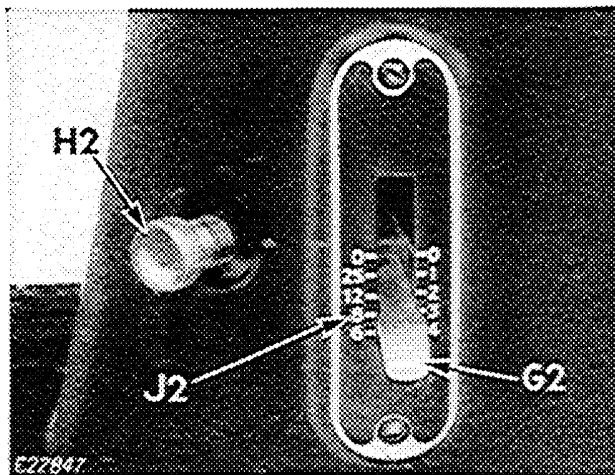

Fig. 27. Regulating Length of Stitch

Settings between 0 and 1 will produce 30 to 25 stitches per inch
 Settings between 1 and 2 will produce 25 to 12 stitches per inch
 Settings between 2 and 3 will produce 12 to 8 stitches per inch
 Settings between 3 and 4 will produce 8 to 6 stitches per inch

TO REGULATE DIRECTION OF FEED

For normal stitching, set the stitch regulator lever **G2** opposite the number indicating the desired length of stitch, as instructed above.

To Back-Tack or reverse the direction of feed, set the lever **G2** for a longer stitch than that desired, then turn the limit screw **H2** inwardly until the lever **G2** is at the number indicating the desired length of stitch. Now move the stitch regulator lever **G2** upward as far as it will go. The machine will then make the same number of stitches per inch feeding toward you as it does when feeding from you, according to the stitch length that has been set. The direction of feed can be reversed at any point in sewing without removing work from machine.

TO REGULATE PRESSURE ON PRESSER FOOT

The surface finish on fabrics, as well as their weight, determines amount of pressure to be applied. The glazed surface of chintzes and polished cottons, the loose nap surface of satins, the deep piled surface of velvets, the delicate and broken surface of laces and brocades, all require a lighter pressure. To set a light pressure, turn thumb screw **K2**, **Fig. 28** upward until fabric moves easily under presser foot without slipping and without showing feed marks. Heavy, spongy fabrics like toweling, chenilles, coatings, etc., require heavier pressure. To set a heavy pressure, turn thumb screw **K2** downward until the fabric moves easily and the seam edges are carried evenly by the foot and the feed.

THREAD TENSIONS

For perfect stitching, the tension on needle and bobbin threads must be heavy enough to pull threads to center of thickness of material and make a firm stitch as shown in **Fig. 29**.

In the unbalanced tensions of **Fig. 30**, the Needle Thread lies straight along top side of material, caused by too heavy tension on needle thread or too light tension on bobbin thread.

In the unbalanced tensions of **Fig. 31**, the Bobbin Thread lies straight along underside of material, caused by too light tension on needle thread or too heavy tension on bobbin thread.

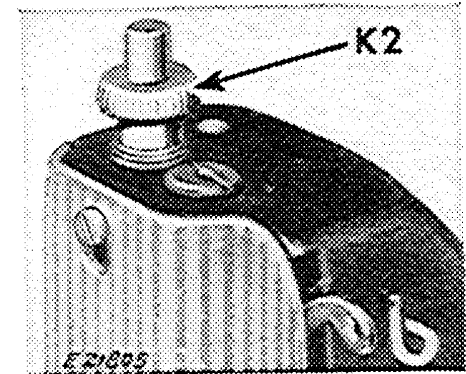

Fig. 28. Thumb Screw For Regulating Pressure on Presser Foot



Fig. 29. Perfect Stitching

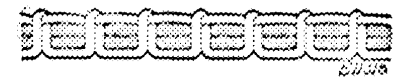

Fig. 30. Imperfect Stitching

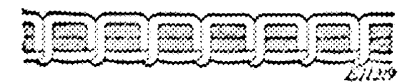

Fig. 31. Imperfect Stitching

TO REGULATE NEEDLE THREAD TENSION

The tension on needle thread can be regulated only when the presser foot is down.

The numerals "0 to 9" on dial **M2**, Fig. 32, indicate different degrees of tension that can be obtained. The numbers do not denote size of thread or ounces of tension.

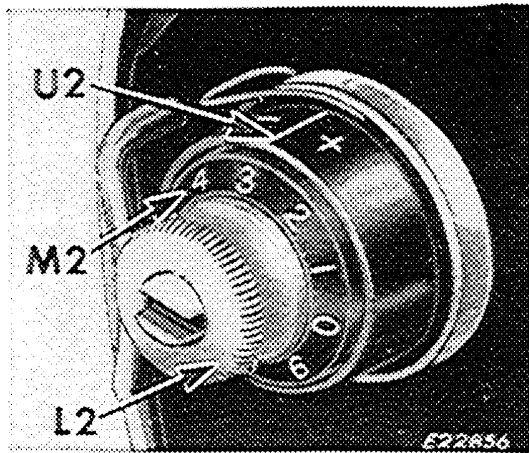

Fig. 32. Needle Thread Tension

To increase tension, turn thumb nut **L2** gradually to right (clockwise) until required tension is obtained. Each **higher** number denotes increased tension.

When tension has been correctly set for average sewing, note number at indicator line **U2** so that this setting may be regained should the tension be altered for special work or change in size of thread.

To decrease tension, turn thumb nut **L2** gradually to left (counter-clockwise) until required tension is obtained. Each **lower** number denotes less tension.

The tension indicator **U2** is marked with the signs $+$ and $-$, which indicate the direction in which to turn the thumb nut for more or less tension.

TO REGULATE BOBBIN THREAD TENSION

The tension on bobbin thread is regulated by the larger screw **Y**, Fig. 33 which is nearest center of tension spring on outside of the bobbin case.

To increase tension, turn screw **Y** gradually over to the right.

To decrease tension, turn screw **Y** gradually over to the left.

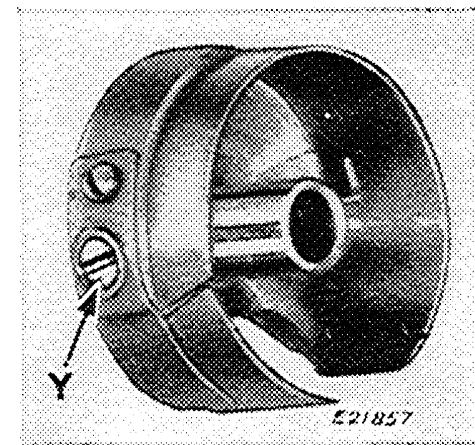

Fig. 33. Bobbin Thread Tension

TO REMOVE AND DISASSEMBLE NEEDLE THREAD TENSION

Turn thumb nut **A** to the left (counter-clockwise) until "0" on dial **C** stops at center line on indicator **G**. To separate pin **B** in thumb nut **A** from dial **C**, press in dial, unscrew thumb nut and remove it. Then remove tension parts from stud **J**, as shown in **Fig. 34**. Do not remove stud **J**.

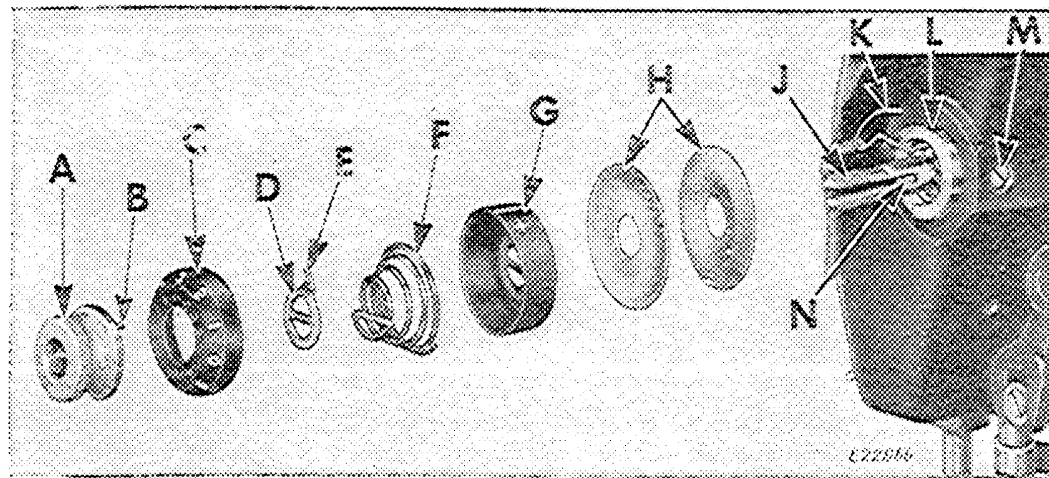

Fig. 34. Needle Thread Tension Assembly

spring **F** in indicator with the first (half) coil of this spring straddling the lower half of the stud. Place stop washer on stud with extension **E** above stud, so that it clears the first (half) coil of tension spring. Next, place dial **C** on stud with No. 2 opposite stop washer extension **E**, then push dial to compress tension spring and at the same time screw thumb nut **A** on stud, inserting pin **B** on nut in one of the holes in dial **C**. Then lower presser bar and turn thumb nut **A** to left until "0" on dial **C** stops at center line on indicator **G**. Thread the tension and pull thread through tension discs to test amount of tension on thread at "0" position.

TO REASSEMBLE AND REPLACE NEEDLE THREAD TENSION

Make sure that tension releasing pin **N** is in place in stud **J**. Replace the tension parts on the stud **J** as follows: Replace the two tension discs **H** with their convex surfaces toward each other. Then replace the indicator **G**, open side out, on stud with plus and minus signs at top, then insert tension

At this point there should be a slight pull on the thread to indicate that there is a minimum tension which gradually increases with the turning of thumb nut **A** to the right, providing a full range of tensions with one revolution of the thumb nut. If the pull is too strong for a minimum tension, press in dial **C** to disengage pin **B** on nut from dial, and reset pin in one of holes at **left** of previous setting. This resetting will produce less tension at "0". Repeat this process until minimum desired tension is obtained.

If there is no tension at "0", press in dial **C** and reset pin **B** on nut in one of holes at **right** of previous setting, repeating this process until a slight minimum

tension is obtained. The tension on thread take-up spring **K** and stroke of this spring should be just sufficient to take up slack of needle thread until eye of needle reaches goods in its descent.

To adjust tension on thread take-up spring **K**, remove tension disc assembly, disengage end of spring from groove in tension stud, revolve spring and place its end in the groove which produces correct tension.

To regulate stroke of thread take-up spring **K**, loosen screw **M**, **Fig. 34**, and turn the thread take-up spring regulator **L**, **Fig. 34**, until correct stroke is obtained, then tighten screw **M**.

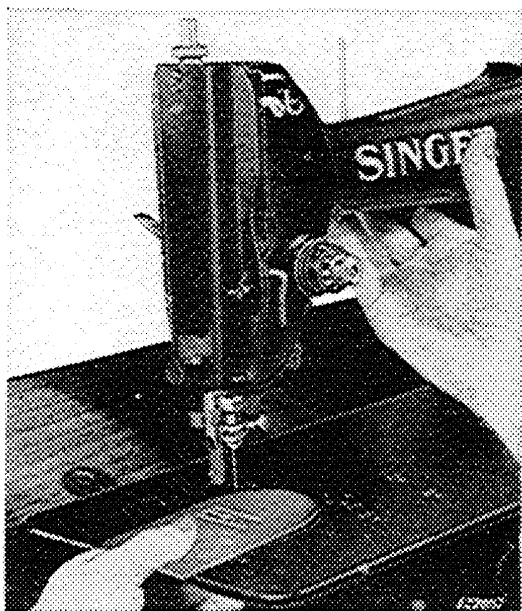

Fig. 35. Changing the Throat Plate

TO CHANGE THE THROAT PLATE

When changing from All-purpose Throat Plate to Straight Stitching Throat Plate, **FIRST** set the Needle Position Lever at its Central Position and set the Bight Lever at 0. Raise the needle to its highest point. Raise the machine head slightly by placing the right hand under the arm of the machine as illustrated in **Fig. 35**.

With the left hand tilt the throat plate by pressing it up from the underside, raising the rounded end enough to clear the feed dog. Then slide the plate to the left.

To Insert the Throat Plate, slip both ends of its spring beneath the edges of the opening, and, while it is slightly tilted, slide it into position.

Lower the machine head into place.

TO COMMENCE SEWING

Be sure to have take-up lever **N2** at its highest point.

Adjust Needle Position Lever (Page 24) and Bight Lever (Page 25) to the desired setting and turn hand wheel over toward you until needle is ready for its extreme left stroke at left needle position; or its extreme right stroke at right needle position. Place the material beneath the presser foot **R2**, position needle in fabric, lower the foot by means of the presser bar lifter **P2** and commence to sew.

- N2** — Take-up Lever
- P2** — Presser Bar Lifter
- Q2** — Thread Cutter
- R2** — Presser Foot
- S2** — Feed Dog

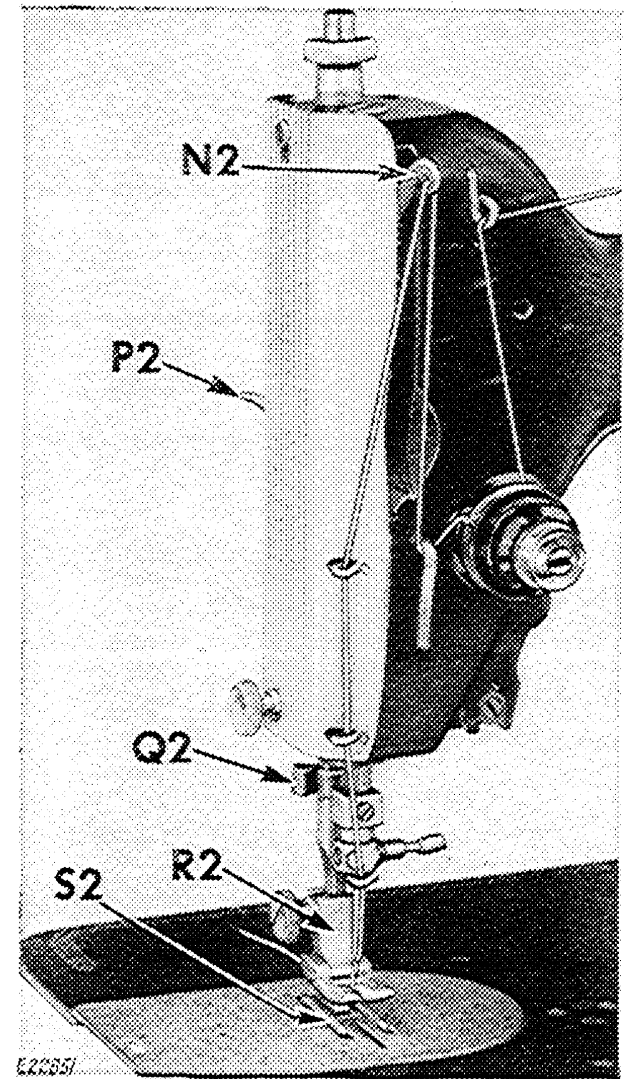

Fig. 36

SEWING SUGGESTIONS

Breaking of needles might be caused by:

1. Wrong size of needle for thread and material—see page 10.
2. Wrong throat plate or presser foot for the type of work being done—see pages 19-25.
3. Wrong setting of needle position lever and/or bight lever—see pages 19, 21, 23, 24 and 25.
4. Pulling of material when stitching—see page 18.
5. Loosely fastened presser foot or special fittings.
6. Wrong class of needle—see page 10.

Breaking of needle thread might be caused by:

1. A knot in thread.
2. Thread too coarse for needle — see page 10.
3. Wrong threading—see pages 12 and 13.
4. Upper tension too tight—see pages 27-30.
5. Needle blunt or bent.
6. Needle set incorrectly—see page 11.
7. Roughened hole in throat plate.
8. Wrong arrangement of threads when starting to sew—see page 17.

Breaking of bobbin thread might be caused by:

1. Wrong threading of bobbin case — see page 16.
2. Bobbin thread tension too tight — see pages 27 and 28.

Skipping of stitches might be caused by:

1. Wrong setting of needle—see page 11.
2. Needle blunt or bent.
3. Needle too small for thread—see page 10.

Stitches looping might be caused by:

1. Wrong threading — see pages 12, 13 and 16.
2. Tensions set incorrectly — see pages 27 to 30.

Gathering or puckering of material might be caused by:

1. Failure to use paper backing when zigzag stitching with a very wide bight and/or on sheer materials.

If machine runs heavily after standing idle for a long period, apply a few drops of kerosene at all oiling points, run the machine for a few minutes, then wipe clean and apply SINGER oil as described on pages 7, 8 and 9.

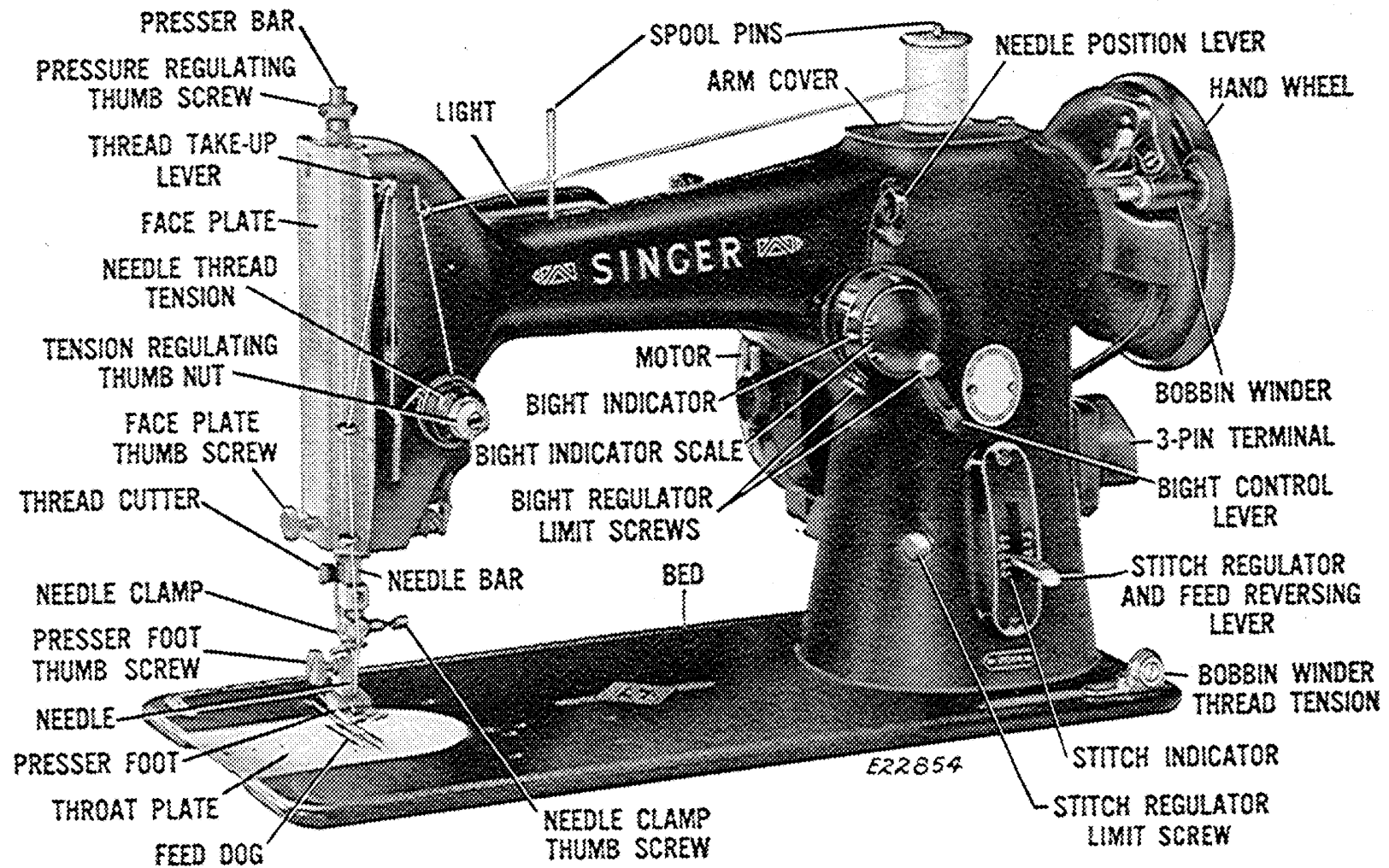
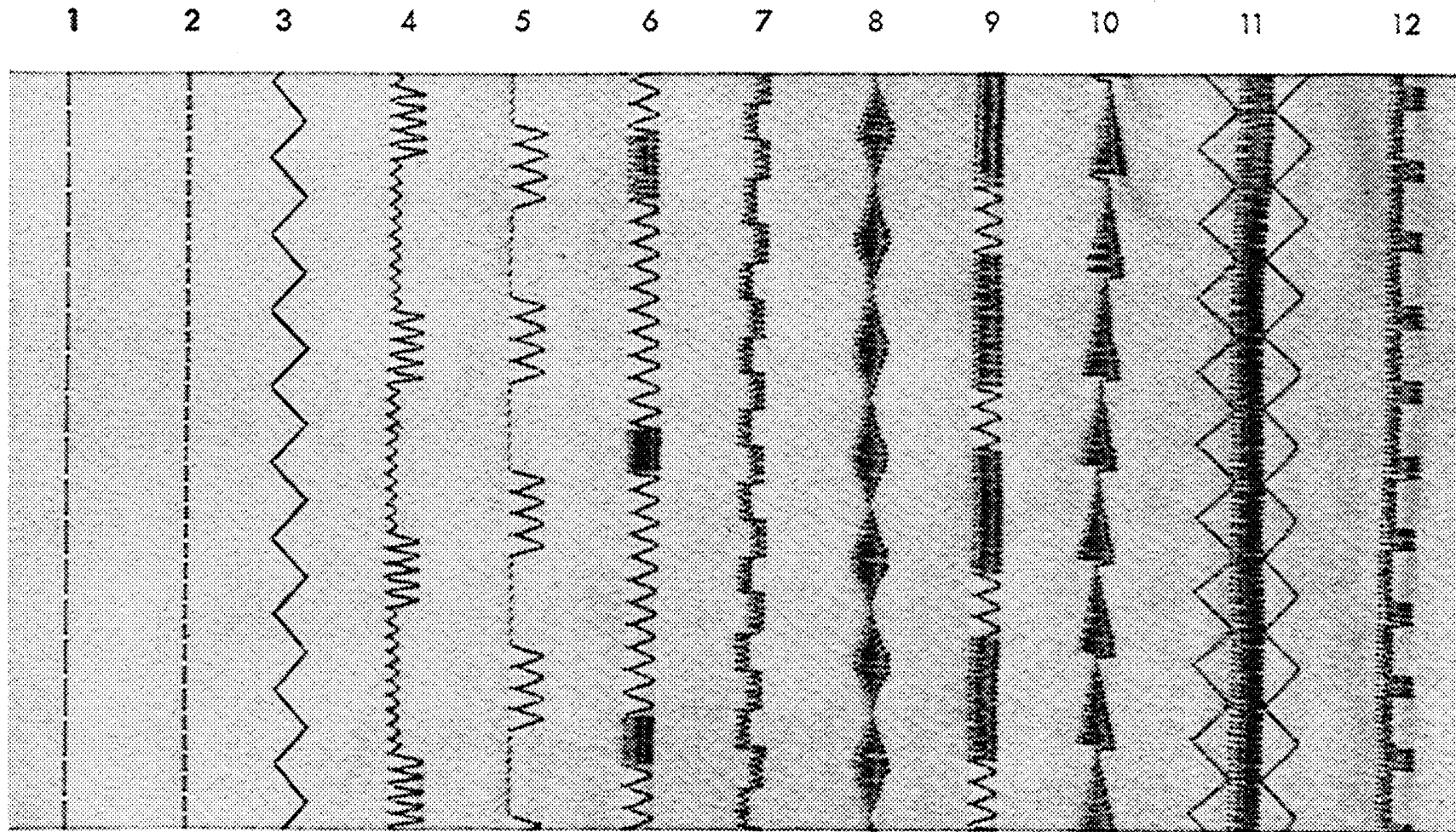

Fig. 37. Names of Principal Parts of Machine 206K43

VARIETY OF STITCHES MADE WITH
ALL-PURPOSE PRESSER FOOT 105069 and ALL-PURPOSE THROAT PLATE 105053



*See corresponding stitch numbers in chart on following page for key to above stitches.
Stitches Nos. 4, 5, 7, and 12 are made with the LEFT NEEDLE POSITION.
The opposite effect is obtained when the right needle position is used.
Zigzag stitching should be done with paper backing if material gathers.*

KEY TO STITCHES

TYPE OF STITCH	NEEDLE POSITION	BIGHT SETTING	STITCH LENGTH	TENSION	DETAILS REGARDING VARIATIONS OF NEEDLE POSITION AND BIGHT ‡
1. BASTING STITCH	Central	0	6	Light	
2. STRAIGHT STITCH	Central	0	12	Medium	
3. WIDE ZIGZAG	Central, Left or Right	5	6	Light	
4. NARROW and WIDE ZIGZAG	Left	2 alternating with 5	28	Light	At 2 Bight take 20 stitches At 5 Bight take 10 stitches
5. STRAIGHT STITCH and WIDE ZIGZAG	Left	0 alternating with 5	25	Light	At 0 Bight take 8 stitches At 5 Bight take 8 stitches
6. FENCE STITCH	Central	3	25 alternating with 30	Tighter Lower Tension	At 25 Stitch Setting take 20 stitches At 30 Stitch Setting take 20 stitches
7. WALLS OF TROY	Central alternating with Left	2	30	Tighter Lower Tension	At Central Position take 11 stitches At Left Position take 11 stitches Needle IN at Right; Needle UP at Left
8. BEAD STITCH	Central	0 to 5 to 0	30	Tighter Lower Tension	Take 2 stitches at each Bight mark up to 5 Take 2 stitches at each Bight mark back to 0
9. GATE STITCH	Central	3	25 alternating with 30	Tighter Lower Tension	At 25 Stitch Setting take 6 stitches At 30 Stitch Setting take 40 stitches
10. ARROW STITCH	Central	0 to 5 0 to 5	30	Tighter Lower Tension	Take 2 stitches at 0 Bight Take 4 stitches at each Bight mark up to 5 With needle up change to 0 Bight, take 2 stitches and repeat process
11. DIAMOND BACK STITCH	Central for Bar Left for Z.Z. and Right for Z.Z.	5	30—Bar 6—Zigzag	Tight Lower Light Upper	Stitch Bar First Zigzag separately on each side of Bar
12. KEY STITCH	Left	2 to 5	30	Tight Lower	At 2 Bight take 16 stitches At 5 Bight take 8 stitches Needle UP at change of Bight

0 Bight = Zero Bight

5 Bight = Maximum Bight

‡ See instructions on pages 24 and 25

The following pages illustrate and explain methods of performing various sewing operations for both straight stitching and zigzag work on the 206 Machine.

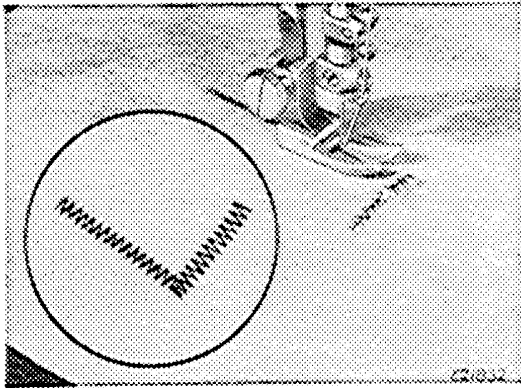

TO QUICKLY MEND A TEAR OR RENT



Use All-purpose Throat Plate, All-purpose Presser Foot, Central Needle Position. Stitch at #2 for 12 stitches per inch. Bight set to width of tear.

TO QUICKLY MEND A TROUSER POCKET, GLOVE SEAM OR WALLET SEAM

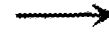

Use All-purpose Throat Plate, All-purpose Presser Foot, Central Needle Position, 3 or 4 Bight, Stitch between #2 and #1 for 12 to 20 stitches per inch, according to fabric.

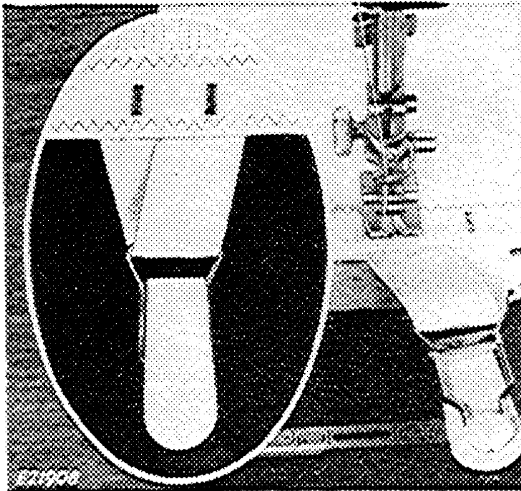

Overlock seam by alternating stitches outside and inside raw edges.

TO REINFORCE HEAVY DUTY GARMENTS, GIRDLES, GARTERS, ETC.

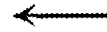

Use All-purpose Throat Plate, All-purpose Presser Foot, Central Needle Position, 3 or 4 Bight, according to need, Stitch between #2 and #1 for 12 to 20 stitches per inch, according to fabric and degree of strain.

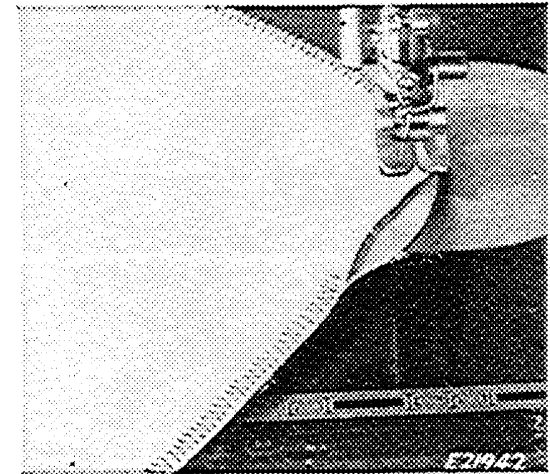

TO RENEW ELASTIC WAISTBANDS OR CUFFS ON LINGERIE KNIT WEAR OR TRICOT

Use **All-purpose Throat Plate, All-purpose Presser Foot**, Central Needle Position, 2 Bight, Stitch at #2 for 12 stitches per inch.

Stretch elastic, while stitching, to degree of fullness required in garment. With top edges of elastic in line with raw edge of garment, zigzag 2 rows at top and bottom of elastic, following cords of elastic.

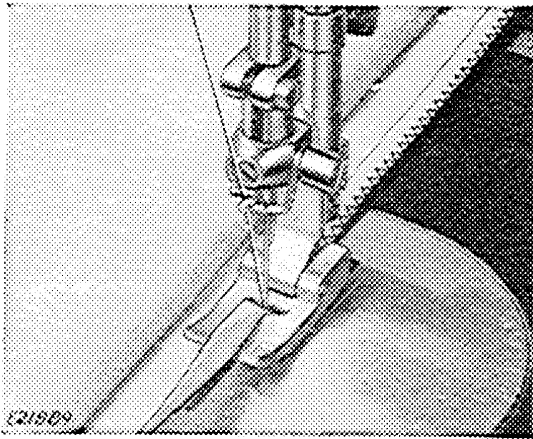
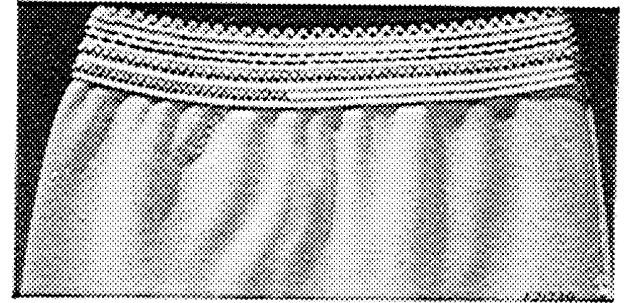

TO OVERCAST OPEN SEAMS

Use **All-purpose Throat Plate, All-purpose Presser Foot**, Central Needle Position, 2 Bight, Stitch at #1½ for 15 stitches per inch.

Turn raw edge toward wrong side and, while stitching, let it pass over flanged toe of All-purpose Presser Foot and through slot. Guide material so that needle, when vibrating to right, pierces material exactly at edge.

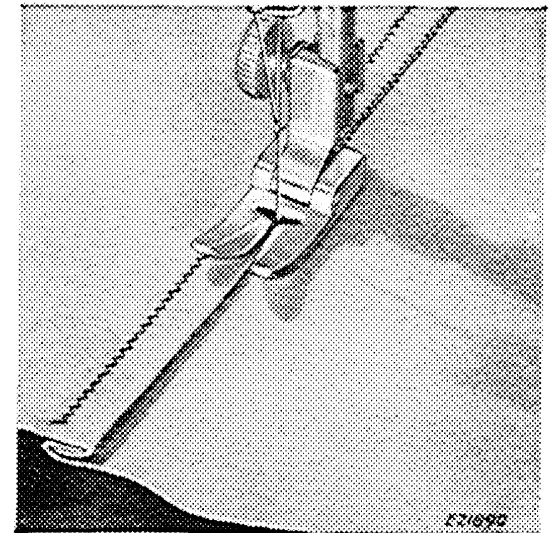

HEAVY DUTY, STRAIN-PROOF AND REVERSIBLE SEAM

Use **All-purpose Throat Plate, All-purpose Presser Foot**, Central Needle Position, 2 Bight, Stitch at #1½ for 15 stitches per inch.

For heavy duty, strain-proof seams, use double interlocked seam, zigzagged on both sides. Turn **under** raw edge of one section, and turn **up** raw edge of joining section. Interlock two raw edges and zigzag across one seam on right side and across other seam on wrong side, producing a double fell, doubly re-enforced, with elasticity against strain when wearing.

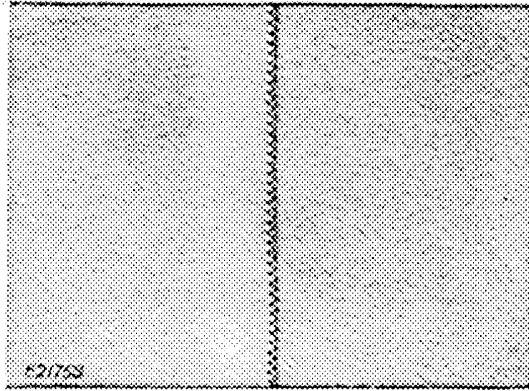
RIP-PROOF SEAM FOR LINGERIE

←
For rip-proof seams in lingerie, first straight stitch fitted seam on wrong side and press both edges to one side.

Use Central Needle Position,

0 Bight,

Stitch at #1½ for 15 stitches per inch for straight stitching.

On right side of garment, top stitch with a fine zigzag stitch letting needle first enter channel of seam, then seam thickness.

Use **All-purpose Throat Plate, All-purpose Presser Foot, Central Needle Position, 2 Bight, Stitch at #1 for 25 stitches per inch for zigzag stitching.**

CHANNEL SEAM FINISHED WITH CROSSED TOP STITCHING FOR ACCENT

First assemble seam with basting stitch (see **Pages 34 and 35**),

Use Central Needle Position, 0 Bight, 6 Stitch.

Press seam open and cut a strip, of contrasting fabric, the same width as open seam, attaching raw edges to both sides of open seam with zigzag stitches.

Use **All-purpose Throat Plate, All-purpose Presser Foot, Central Needle Position, 5 Bight, Stitch at #2 for 12 stitches per inch.**

Turn to right side and top stitch with straight stitch in same color as channel strip, on both sides of seam and, for additional accent, crossing at center. See **pages 34 and 35** for straight stitch. Remove basting stitch from original seam.

SLOT SEAM FINISHED WITH ARROWHEADS FOR ACCENT AND RE-ENFORCEMENT

←
Slot seam is made like channel seam except that opened seam is machine basted to contrasting strip on wrong side. After top-stitching, all original basting lines are removed. The arrow is made by following procedure outlined on **pages 34 and 35, line 10**, and may be used singly, or doubly to accommodate width of seam. When made double, use Left Needle Position with Bight setting at 5 and diminishing to 0; pivot at 0 and continue from 0 to 5 Bight in same proportion.

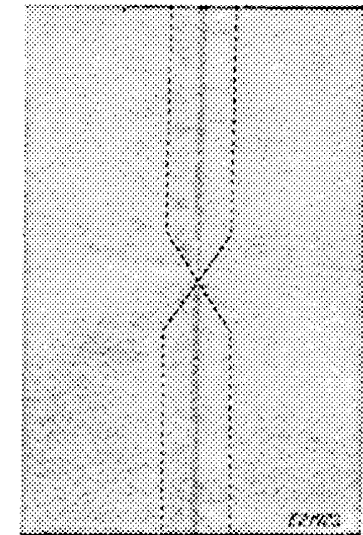
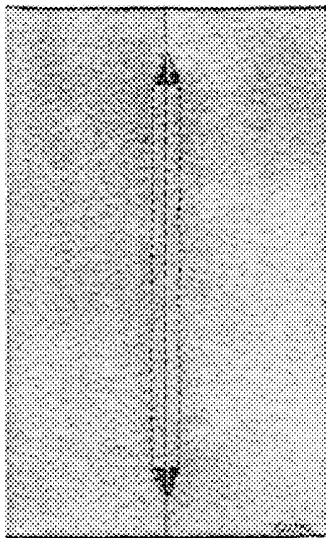

HAIRLINE SEAM IN TRICOT

For a strong elastic seam, in Tricot weaves, that will not curl or lose its shaping, zigzag along seam line, then cut surplus seam away, near line of stitching. Turn to right side and press.

Use **All-purpose Throat Plate,**
All-purpose Presser Foot,
 Central Needle Position,
 2 or 3 Bight,
 Stitch at #1 for 25 stitches per inch.

(This seam is also quick and efficient for closely woven cottons.)

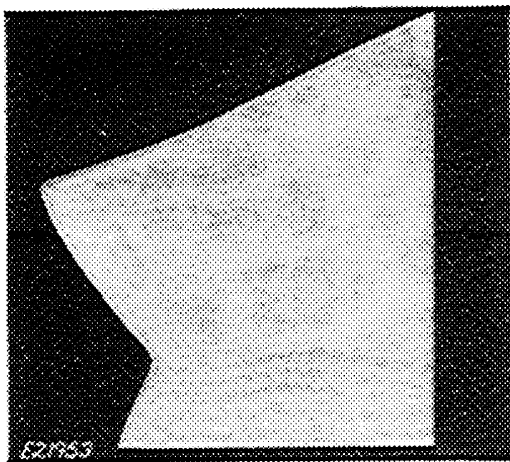
**HAIRLINE SEAM IN SHEERS**

For a dainty hairline seam in Sheers that is also fray-proof, follow shaped seam line with a fine cording stitch, then cut surplus seam away close to line of stitching. This type of seam may be used either inside or outside.

CORDING SEAM WITH EMBROIDERY FOOT 189651

Place a thread in fan-shaped groove beneath this foot, and cover thread with closely spaced zigzag stitches.

Use **All-purpose Throat Plate,**
Embroidery Foot 189651,
 Central Needle Position,
 2 Bight,
 Stitch at # $\frac{1}{2}$ for about 27 or 28 stitches per inch.

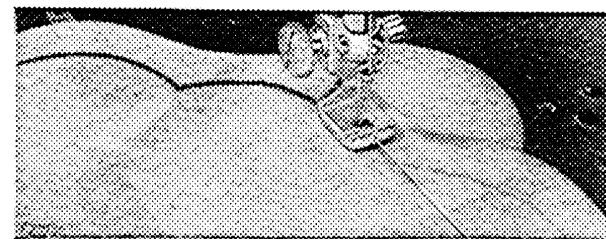
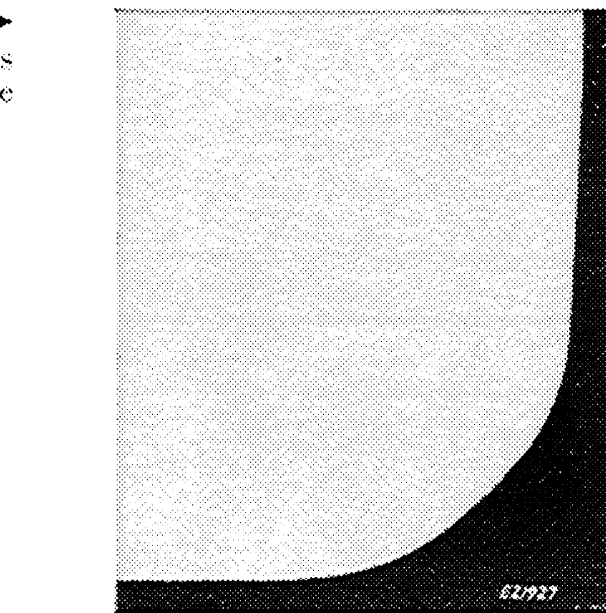

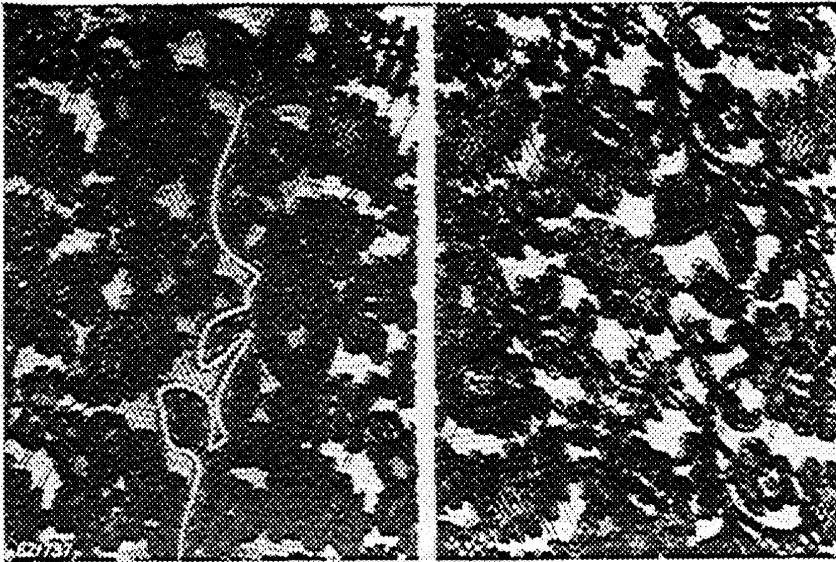

Fig. 50. Invisible Seam for All-Over Lace

Use **Embroidery Foot 189651** to follow curves of lace motif more easily,
 Central Needle Position,
 1½ Bight,
 Stitch at nearly 0 for 30 stitches per inch.
 Cut away excess seam up to stitching on both right and wrong sides, using curved embroidery scissors.

INVISIBLE SEAM FOR ALL-OVER LACE OR LACE EMBROIDERY

After seams have been basted and fitted, mark outline of seam on both sections of garment with hand basting. Remove basting that joined seams and lay one section over other with seam lines matching and hand baste. Remove marking stitches. Embroidery Foot 189651 (see page 23) is used to follow outline of lace motif that runs through seam lap.

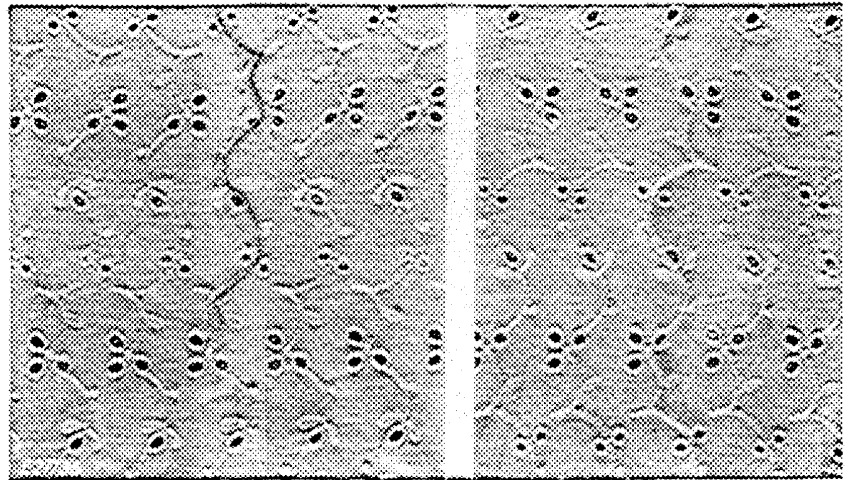
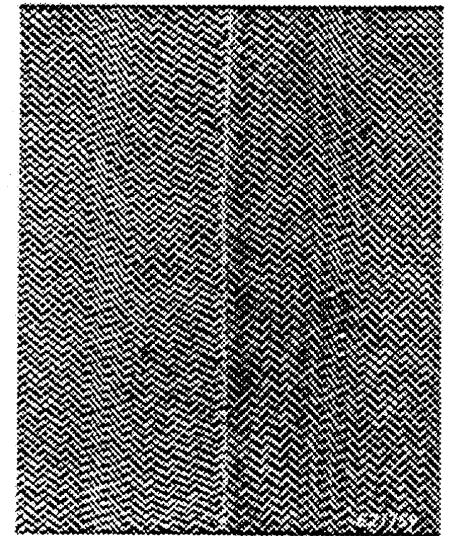
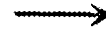
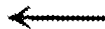

Fig. 51. Invisible Seam for All-Over Lace Embroidery

INVISIBLE SEAM FOR HORSEHAIR OR NET BANDINGS

Use **All-purpose Throat Plate,**
All-purpose Presser Foot,
 Central Needle Position,
 1½ Bight,
 Stitch at #1 for 25 stitches per inch.

Guide braid or banding so that edges are abutted as they meet when passing under slot of foot.

**DECORATIVE ABUTTED SEAM FOR LOOPS AND STRAPS**

Decorative abutted seams for loops and straps are particularly good for Tricot lingerie. Cut crosswise strips, exactly ¾" wide. Turning both raw edges so that they meet at the center, insert the fold through slot of All-purpose Presser Foot and zigzag raw edges together along center.

Use **All-purpose Throat Plate,**
All-purpose Presser Foot,
 Central Needle Position,
 2 Bight,
 Stitch at #1½ for 15 to 18
 stitches per inch.

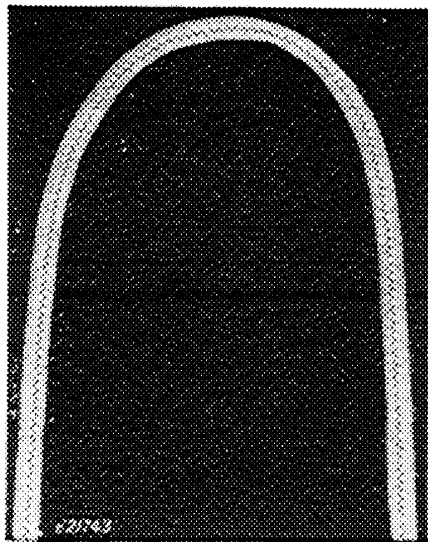
**TORSO OR SHAPED DARTS**

Torso or shaped darts are stronger and more flexible when stitched with a shallow zigzag.

Use **All-purpose Throat Plate, All-purpose Presser Foot,**
 Central Needle Position, 1 Bight, Stitch at #2 for 12
 stitches per inch, Lighter Tensions.

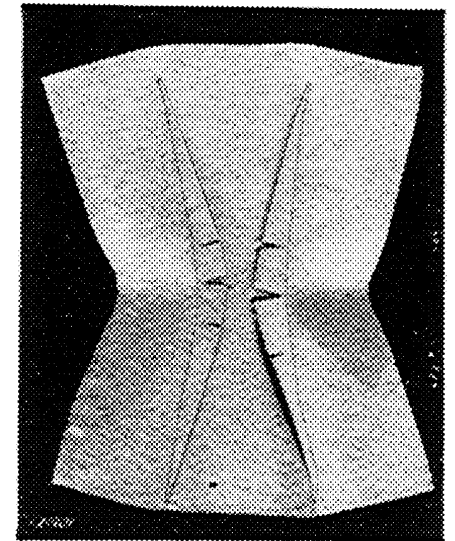
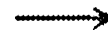

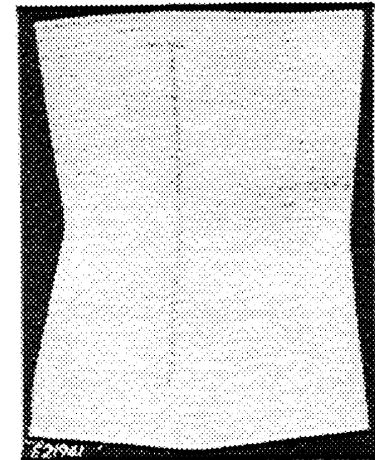
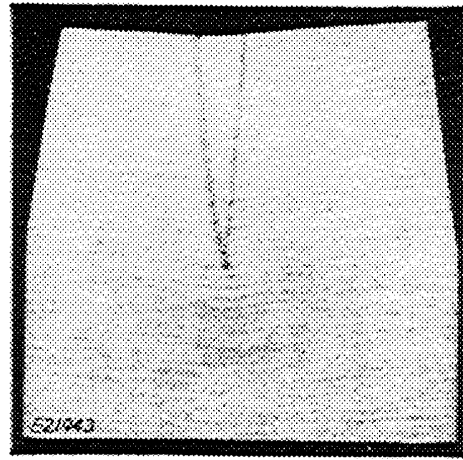
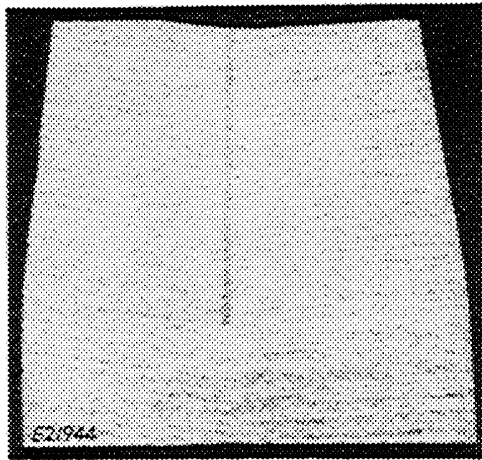
CONTOUR DARTS IN INTERFACING*Fig. 55. Contour Darts in Interfacing*

Contour Darts in Interfacings provide permanent shaping without bulk when cut, lapped and zigzag stitched along raw edges.

Use **All-purpose Throat Plate, All-purpose Presser Foot, Central Needle Position, 5 Bight, Stitch at #1 for 25 stitches per inch, Light Tensions.**

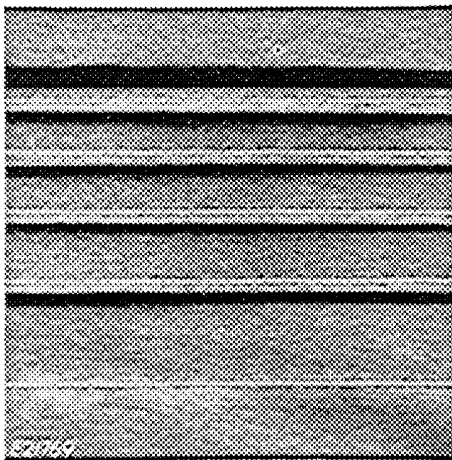
*Fig. 56. Graduated Tucks***GRADUATED AND SHUTTER TUCKS**

Decorative Tucks may be quickly made by laying fold of tuck in line with right toe of All-purpose Presser Foot and zigzagging in contrasting thread.

Use **All-purpose Throat Plate, All-purpose Presser Foot, Central Needle Position, 2 Bight, Stitch at #2 for 12 stitches per inch.**

Graduated Tucks and Shutter Tucks may be made by following along markings with straight stitching (line 2, pages 34 and 35).

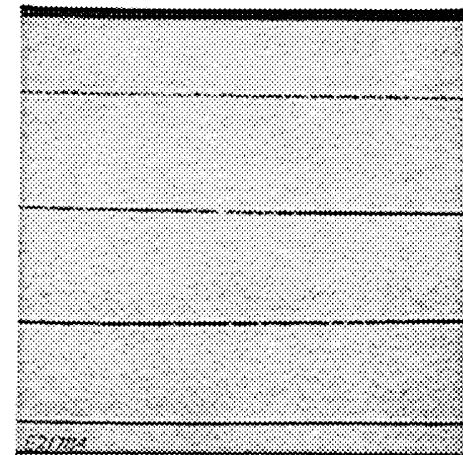
*Fig. 57. Shutter Tucks*

DESIGNER'S TUCKS

Designer's Tucks, contour making and flattering, are formed by pairs of tapered tucks radiating from a common center and stitched on the wrong side.

The points of Designer's Tucks are further accented by tiny arrowheads worked in silk to meet seams of radiating tucks in contrasting color. For making arrowheads, see **line 10, pages 34 and 35.**

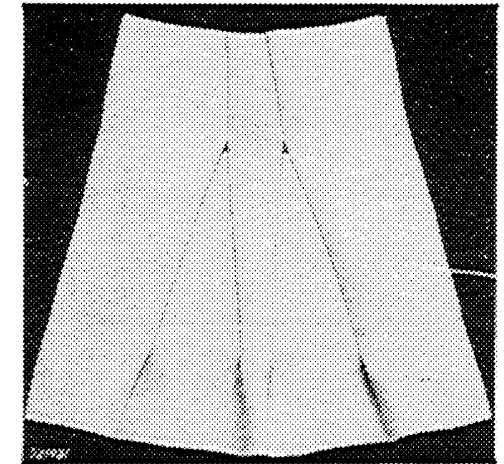

CONTOUR SHIRRINGS

For Contour Shirrings wind Dacron thread on bobbin, and use mercerized or silk thread in needle.

Straight stitch (see **pages 34 and 35, line 2**), using toe of **All-purpose Presser Foot** as guide for $\frac{1}{4}$ " spacings or follow pattern markings. Draw needle threads to underside, and tie to bobbin threads on *one* end of cluster only. Draw on loose hanging, strong Dacron threads to distribute fullness, then tie. Finish by making a pin-tuck at each end of cluster on wrong side.

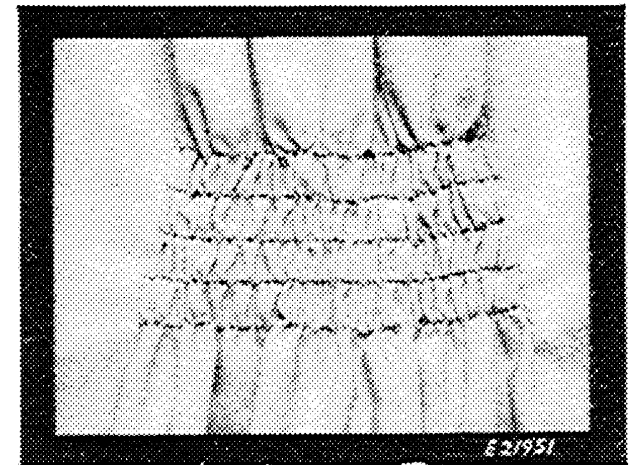

Fig. 61. Contour Shirrings Completed

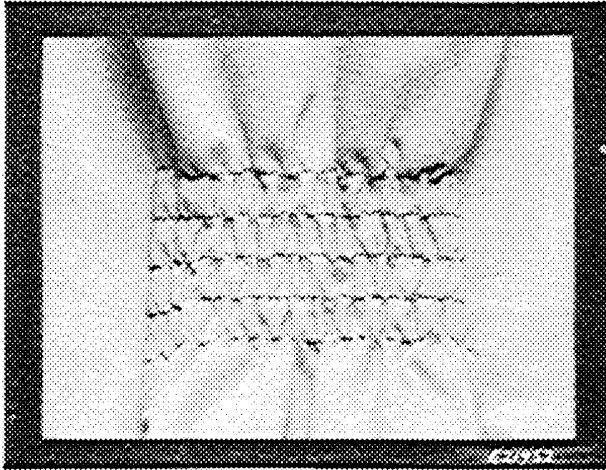

Fig. 62. Elastic Shirrings

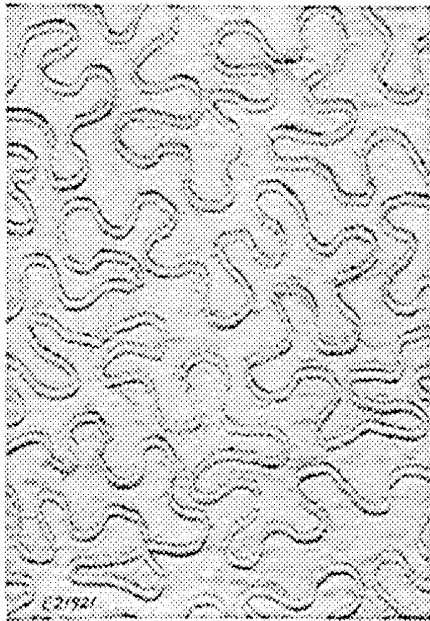

Fig. 63. French Quilting

ELASTIC SHIRRINGS

Elastic Shirrings are made same as Contour Shirrings except that elastic thread is wound on bobbin and need not be drawn. After bringing needle thread to wrong side, tie and finish with pin-tuck at each end of cluster. When used for cuffs, waistbands, etc., the ends may be fastened by the stitching of the closing seam.

FRENCH QUILTING

French Quilting, underlaid with taffeta, organdy or hair-cloth (Armo) for stiffening, or with flannel for weight, may be made with wide or narrow zigzag stitches following an open ornamental design.

Use **All-purpose Throat Plate,**
Embroidery Foot 189651 (see page 23),
 Central Needle Position,
 3 Bight,
 Stitch at almost 0 for 30 stitches per inch.

ITALIAN QUILTING

Italian Quilting may be done on sheers underlaid with soft silk of contrasting or matching color, or on fine soft wools or satins underlaid with silk. Stamp pattern on underlying fabric and baste to section to be quilted.

Follow pattern with small straight stitches (about 25 per inch), and Use **All-purpose Throat Plate**, or **Straight Stitching Throat Plate** (see Page 20), **Quilting Foot 35932** (see page 21), **Central Needle Position**, **0 Bight**.

After pattern has been stitched, thread a heavy, blunt point, crewel hand needle with soft knitting yarn, and insert needle between underlay and surface fabric. Carry knitting yarn through design of pattern between stitches.

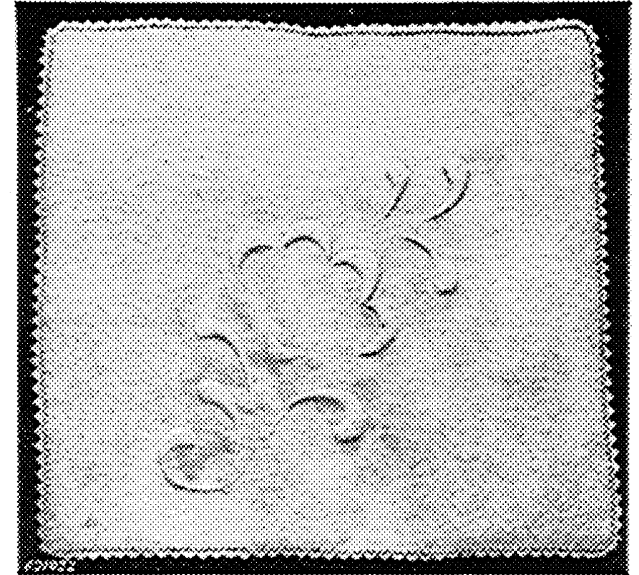
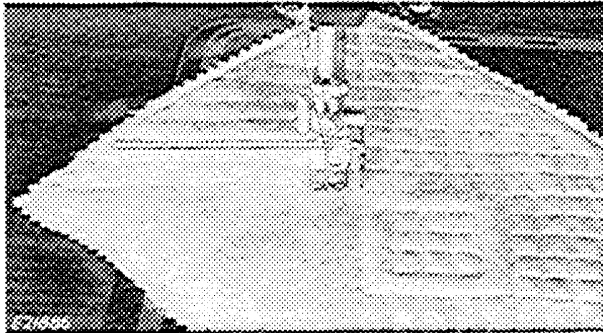

GEOMETRIC QUILTING

Geometric quilting may be done with underlay of any fabric or filler, but it is usually best with cotton batting. Patterns may be stitched without stamping or marking, if Guide is used with Quilter. Vertical, horizontal, or diagonal lines may be used to form box, bar or diamond patterns. Quilter Guide does not touch fabric but may be set same distance from needle that lines of quilting should be spaced. The Guide being in line with last row stitched ensures accurate spacing of each line added.

Use **Straight Stitching Throat Plate** (see page 20), **Quilter** (see page 21), **Central Needle Position**, **0 Bight**,
 #2 to #1½ Stitch for 12 to 15 stitches per inch.

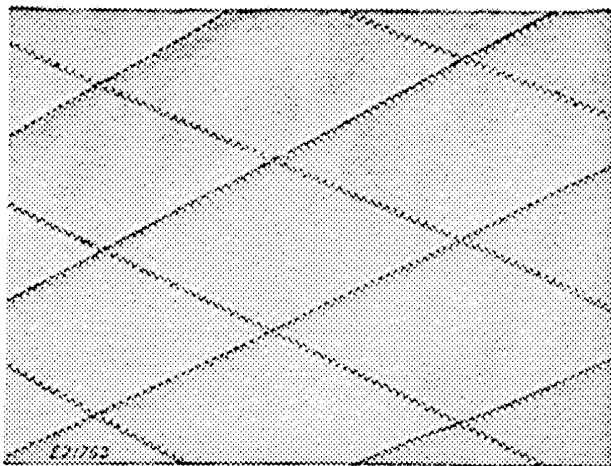

ACCENTED QUILTING



For Accented Quilting follow same procedure as for Geometric Quilting, but wind contrasting thread or yarn on bobbin for accent, using #5 Pearl Cotton, Buttonhole twist, or Metallic threads. Loosen tension on bobbin (see page 28), to accommodate the yarn employed. Set stitch length between #3 and #4 for 6 to 8 stitches per inch and follow design on wrong side so that accenting bobbin thread or yarn will appear on right side when finished.

TO SEW ON BUTTONS

Lower the feed as instructed on page 90.

Use All-purpose Throat Plate,
Button Sewing Foot 189648,

Left Needle Position,
Approximately 3 Bight,
0 Stitch Setting.

Position button, center needle in left hole of button and lower the Button Sewing Foot over it. Test Bight setting by turning hand wheel over towards you once by hand, to be sure that needle enters center of right hole. Then stitch. Needle should enter each hole of button six times. To fasten stitch, set Bight at 0 and take 3 straight stitches in left hole of button. If a thread shank is desired, place a blotter between button and fabric, breaking it away when last stitch has been taken.

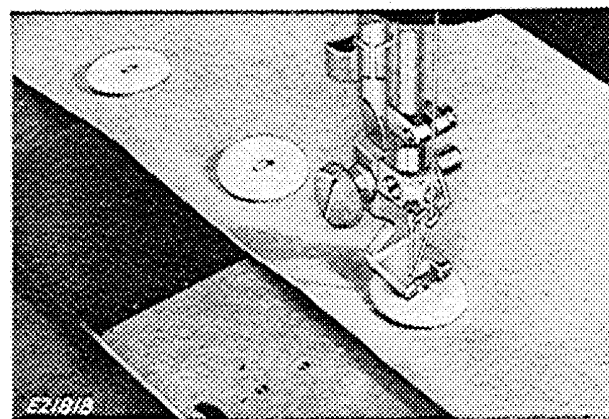
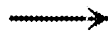

TO SEW ON SNAPS AND HOOKS AND EYES

No **Presser Foot** is used for sewing on snaps. Instead, hold snap in place with tweezers, stiletto, or the point of embroidery scissors.

Lower the feed as instructed on page 90.

Use **All-purpose Throat Plate,**
Left Needle Position,
0 Stitch setting,
2 Bight.

Centering needle in first hole, take 6 overedging stitches, leaving needle in hole at left position on last stitch. Change Bight to 0 and take 3 fastening stitches. Carrying thread across snap, center needle in next hole and **change Bight to 2**. Take 6 overedging stitches, then **returning Bight to 0**, take 3 fastening stitches. Continue this process with each hole.

The same procedure and settings are followed when sewing on hooks and eyes except that after taking 6 overedging stitches in first hole of hook, leave needle in center of hole and turn work so that next 6 overedging stitches will carry across bar of hook, then proceeding to second hole, take 6 overedging stitches and changing Bight to 0, finish with 3 fastening stitches.

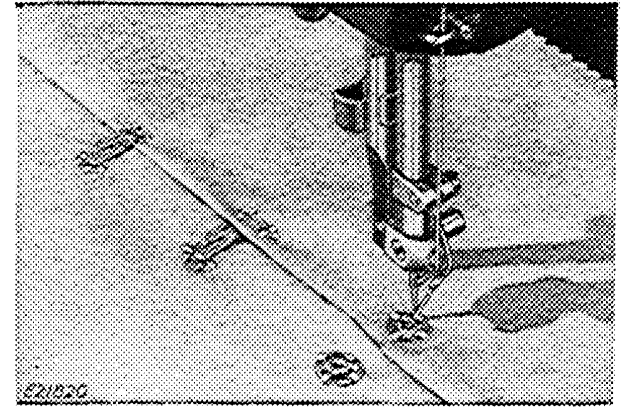

Fig. 68. Sewing on Snaps and Hooks and Eyes

Follow same procedure for sewing on eye, taking 6 overedging stitches in first hole, 6 overedging stitches across to second hole, 6 overedging stitches to side of hole, and, changing Bight to 0, finish with 3 fastening stitches.

TO MAKE BUTTONHOLES

Step 1. Marking the Material

Mark position and length of buttonholes with basting stitches (see Fig. 69) or marking chalk, allowing an extra $\frac{1}{16}$ " in width for cutting space and an extra $\frac{1}{4}$ " in length for $\frac{1}{8}$ " bar allowance on each end.

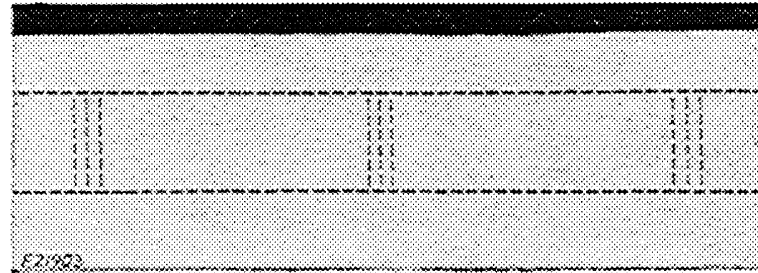

Fig. 69. Marking Location of Buttonholes with Basting Stitches

Step 2. Setting the Machine

Use **All-purpose Throat Plate**,
Buttonhole Foot 86616 (see page 22),
 Left Needle Position (see page 24),
 Almost 0 Stitch (28 stitches per inch),
 2 Bight for side Stitches of Buttonhole,
 5 Bight for Barring Stitches,
 0 Bight for Fastening Stitches.
 (Note slot in Buttonhole Foot for drawing needle and bobbin threads through.)

Step 3. Guiding

Set bight regulator at 2, position needle just left of central marking ready for left swing, and stitch, using point of buttonhole foot as a guide to keep stitches just left of central marking and astride side marking.

CENTER LINE
OF BUTTONHOLE

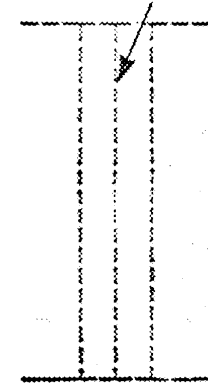

Step 1

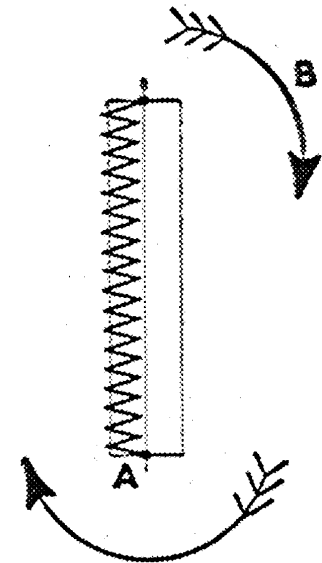

Step 3

Step 4. Pivoting

When point of buttonhole foot reaches end of marking, leave needle in fabric at the point nearest central marking, as shown by **A** in illustrations.

Raise buttonhole foot and, using needle as a pivot, turn work around clockwise, as indicated at **B**. Lower buttonhole foot and take one (1) stitch, leaving needle in buttonhole marking at point **C**.

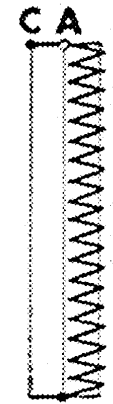

Step 4

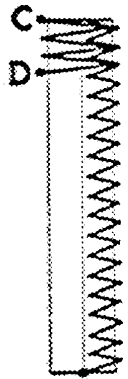

Step 5

Step 5. Barring

Set bight regulator at 5 for widest swing and take six (6) stitches, leaving needle in fabric at point **D** at left.

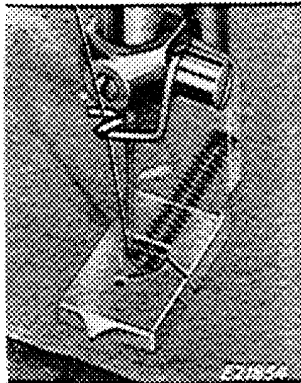
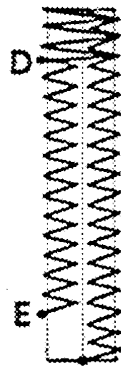

Fig. 70.



Step 6

Step 6. Finishing Buttonhole Edge

Return bight setting to 2 and stitch final edge of buttonhole, keeping point of buttonhole foot just left of central marking to provide sufficient cutting space.

Stop within six stitches of end, leaving needle in fabric at point **E** at outside marking. This point may be easily determined, while stitching, by observing last stitch in first row at lower edge of opening in buttonhole foot.

Step 7. Finishing Final Bar and Fastening Stitch

Set bight regulator at 5 for widest stitch and take six (6) stitches to complete final bar. Set bight regulator at 0 and stitch length at 0 and take three (3) fastening stitches at point **F**. Cut buttonhole along line of center marking.

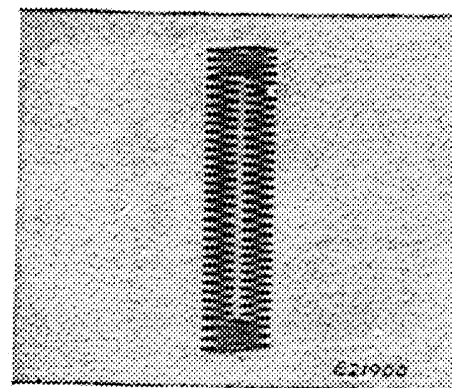
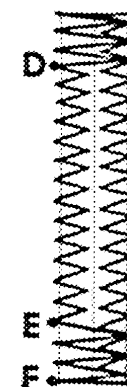

Fig. 71.



Step 7

Raised or Gimp Buttonholes

Insert No. 8 Pearl Cotton or Cordonnet Thread through eyelet in front of buttonhole foot, as shown in Fig. 72 and proceed as for regular buttonholes as instructed on pages 48 and 49.

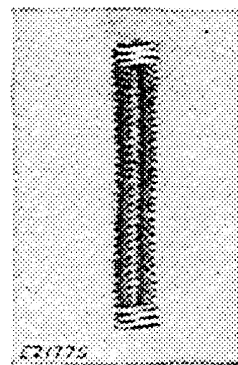
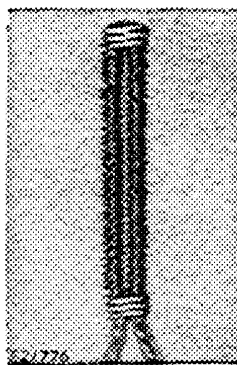

Fig. 73. Gimp Buttonholes

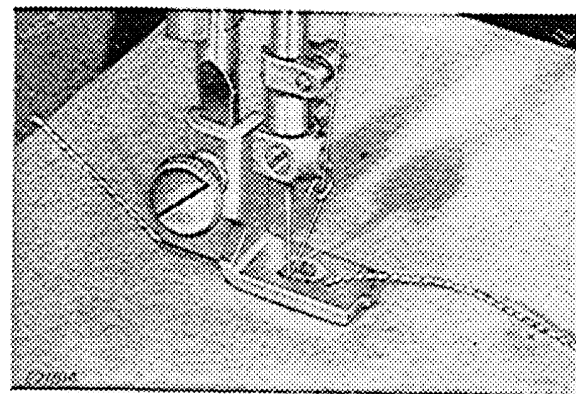

Fig. 72. Making Gimp Buttonhole

BLIND STITCHED ZIPPER INSERTION

On chiffons, sheers, velvets and all delicate fabrics, zippers may be inserted with a blind stitch, equal to invisible hand stitching, by using Right and Left Cording Feet. Allow seams $\frac{1}{4}$ " deeper than average. Use machine basting with stitch length set at 4, or about 6 stitches per inch, to close placket on seam line.

Turn a fold in back seam allowance $\frac{1}{8}$ " from basted seam line and pin this fold to Zipper Tape, rolling both over finger, while pinning, to ease fabric. Baste and machine stitch fold to tape, using stitch length set at #2 for 12 stitches per inch. Apply with Cording Foot (left toe)—see **page 20**.

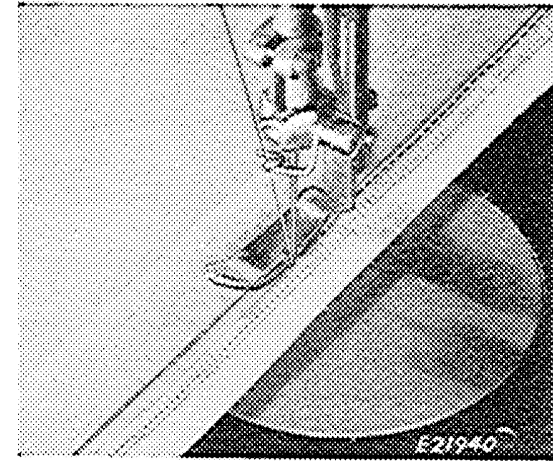

Fig. 74. Cording Foot (left toe) Applying Fold to Zipper Tape

Turn garment right side out and pin front zipper tape into position, placing pins on right side of garment, through all thicknesses, while rolling over finger to ease fabric. Baste about $\frac{3}{8}$ " from seam line to provide guide for Blind Stitching.

Use **All-purpose Throat Plate,**
Cording Foot (right toe)—see **page 20,**
 Central Needle Position,
 2 Bight,
 #4 Stitch Setting.

Turning garment inside out, lay slide fastener over feed of machine and turn back front section of garment to line of basting, creating a soft fold.

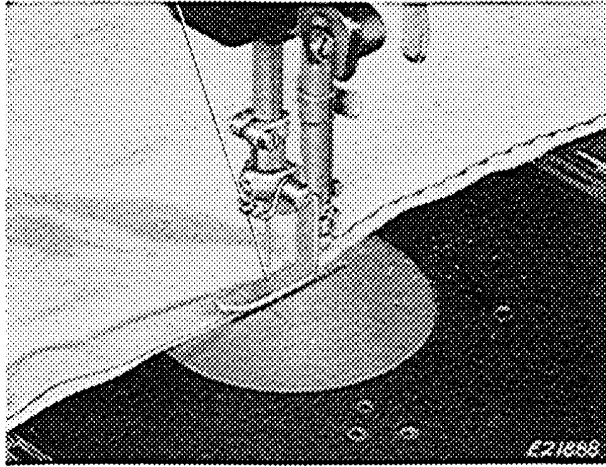

Fig. 75. Blind Stitching Zipper

Move Central Needle Position slightly to left and, positioning needle in seam of fold, lower the Cording Foot (right toe). Take first stitch through zipper tape and front seam. Take next stitch through fold of front section and continue to alternate catching a thread or two of fabric fold as needle swings to left.

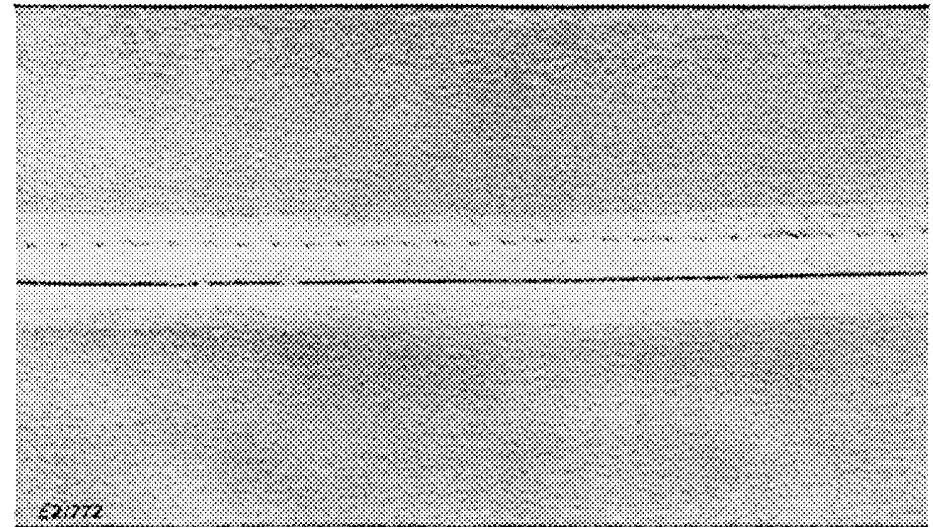

Fig. 76. Blind Stitched Zipper Insertion

BLIND STITCHED HEMS

Use **All-purpose Throat Plate,**
Cording Foot (right toe) 160846,
 Central Needle Position,
 2 Bight,
 Stitch at #4.

Follow same procedure as for Blind Stitching Zipper (see **pages 51 and 52**). For best results use a fine needle and fine thread matching color of fabric. Mark, baste and press hem same as for hand stitching, keeping basting stitches at least $\frac{1}{4}$ " from upper fold of hem.

BLIND STITCHED HEM WITH FOLDED EDGE

After basting, turn hem toward right side of garment, creating a soft fold in garment section and exposing folded edge of hem. Lay hem against feed of machine as shown in **Fig. 77**. Position needle in seam of fold ready for **right** swing and lower the Cording Foot (right toe). Take the first stitch through folded edge of hem, next stitch through fold of garment, and so alternate, catching just a thread or two of the fabric fold, as needle swings to left.

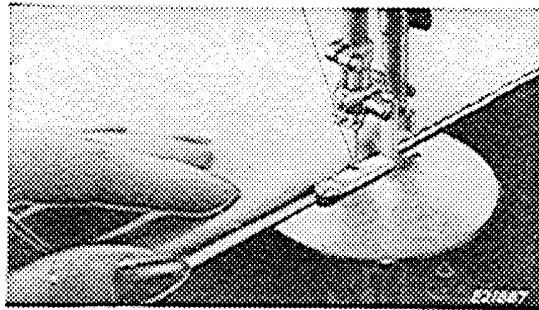

Fig. 77. Blind Stitching with Folded Edge

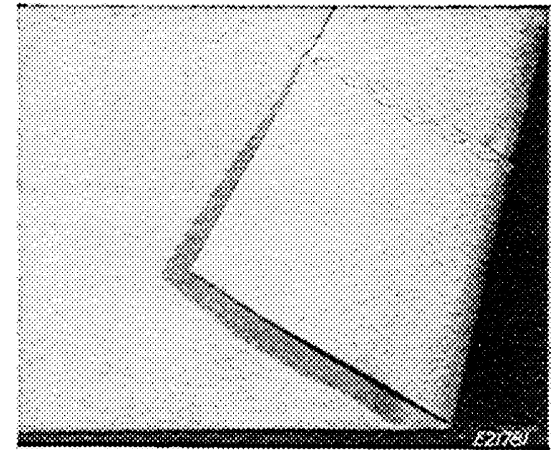

Fig. 78. Blind Stitched Hem

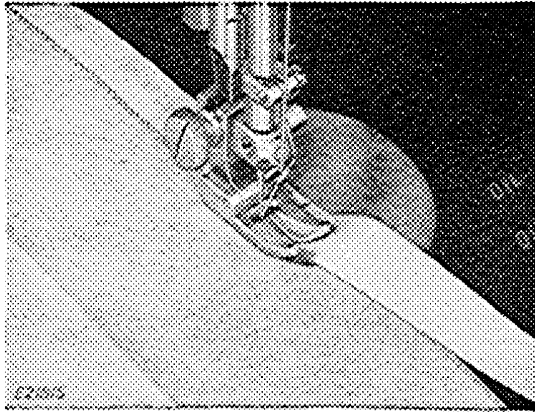

Fig. 79. Attaching Seam Tape to Raw Edge of Hem with All-purpose Foot

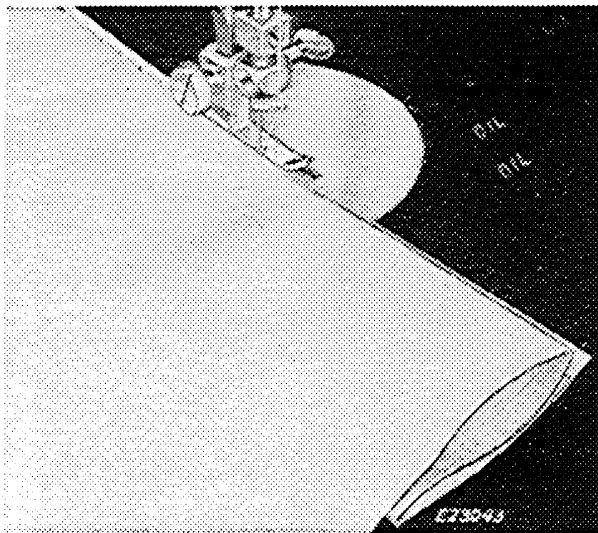

Fig. 80. Blind Stitching Hem with Seam Tape Finish

BLIND STITCHED HEM FINISHED WITH SEAM TAPE

Seam tape is first stitched to raw edge of garment.

Use **All-purpose Throat Plate**,
All-purpose Presser Foot,
Central Needle Position,
1 Bight, #1 Stitch.

Turn hem to the desired depth and baste about $\frac{1}{4}$ " from edge of seam binding.

Use **Cording Foot (right toe)**,
Central Needle Position,
2 Bight, #4 Stitch.

Turn hem toward right side, exposing the $\frac{1}{4}$ " free edge of seam tape, upon which Cording Foot (right toe) is lowered. Follow same procedure as for Blind Stitching a hem with folded edge.

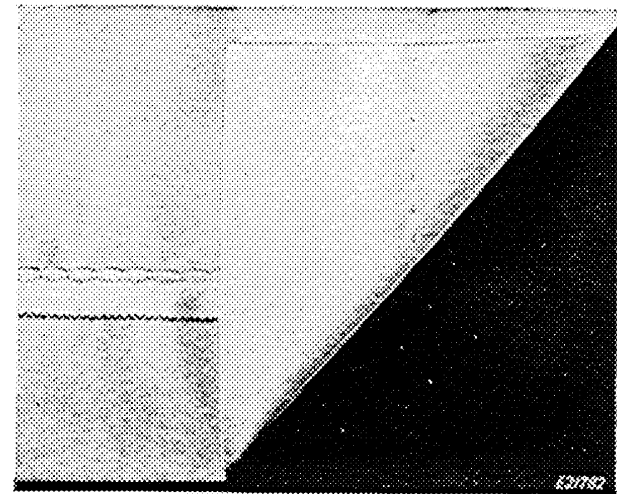

Fig. 82. Blind Stitched Hem with Seam Tape

SHADOW HEMS FOR TRICOT WEAR

Use **All-purpose Throat Plate,**
All-purpose Presser Foot,
 Central Needle Position,
 2 Bight and #1½ Stitch setting.

After marking garment for length desired, turn on the markings and baste for depth desired. With All-purpose Presser Foot follow just below basted line and trim away raw edge close to stitches. This method may also be used for shadow panels.

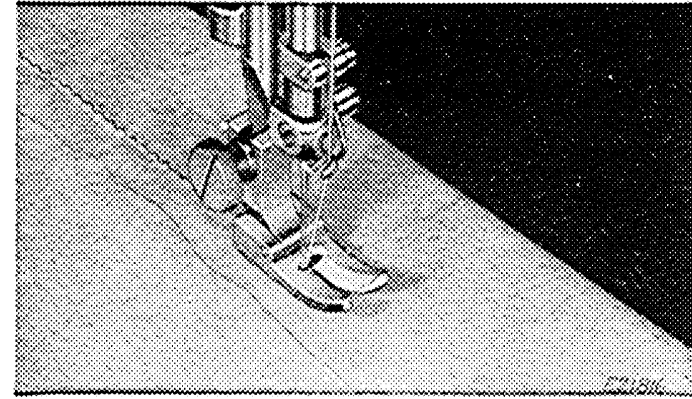

Fig. 83. Stitching Shadow Hem

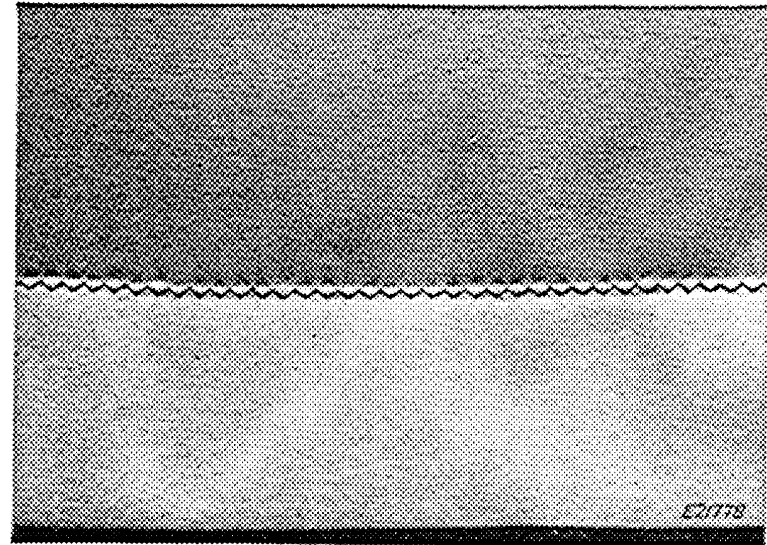

Fig. 84. Finished Shadow Hem

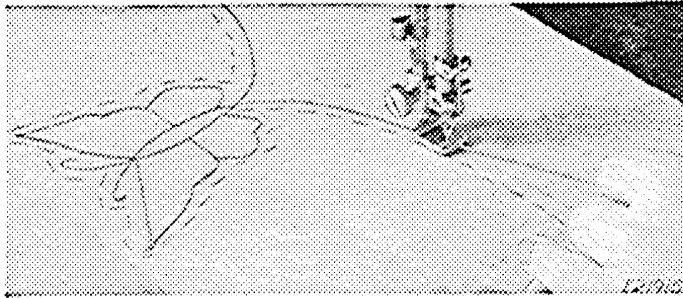

Fig. 85. Appliquéing Hem

Baste hem to full depth of design desired. Stamp or mark design over folded hem on right side of garment. With hand basting follow outline of design about $\frac{1}{4}$ " from lines as shown in **Fig. 85**. Placing a thread in groove beneath Appliqué Foot, follow design by appliquéing thread with closely-spaced stitches, avoiding crossed lines wherever possible. When appliqué is complete, remove bastings and cut away surplus edges from wrong side, close to stitching, using embroidery scissors.

WIDE HEM FOR SHEERS FINISHED WITH APPLIQUÉD CORD

Use All-purpose Throat Plate,
Embroidery and Appliqué Foot 189651
(see page 23),
Central Needle Position,
1 Bight,
Between 0 and 1 Stitch setting.

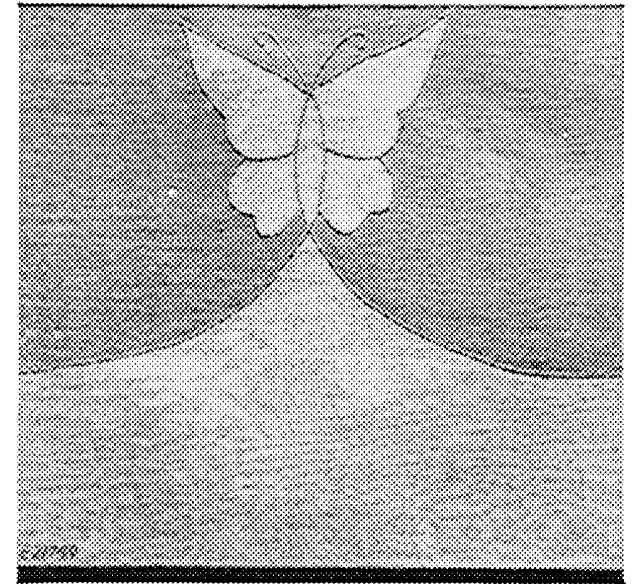

Fig. 86. Appliquéd Shadow Hem

SHELL STITCHED HEMS

Shell Stitched Hems provide a soft, ornamental finish for delicate fabrics, particularly when material is cut on the bias.

Use **All-purpose Throat Plate**,
Shell Hemmer 189653 (see page 23),
 Right Needle Position,
 5 Bight,
 Stitch at #3,
 Tighten both upper and lower
 tensions (see page 28).

Lower Shell Hemmer over raw edge of fabric on wrong side of material. Take one stitch, letting needle enter fabric and rise again. Holding both threads, raise Shell Hemmer, draw the work back and cut off threads on Thread Cutter (Q2, Fig. 36). Still holding both threads, lead raw edge of fabric lightly into scroll of

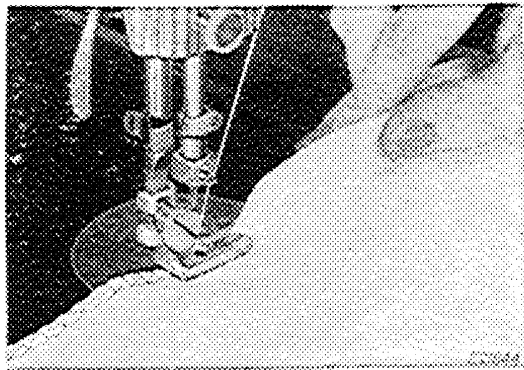

Fig. 88. Making Shell Stitched Hem

Hemmer, drawing on threads to carry it through. On reaching slot of Hemmer, lower the needle into hem, then lower Hemmer and stitch. Many variations of the soft scallop may be obtained by using different stitch settings and threads of various types in matching or contrasting colors. Metallic Thread or Buttonhole Twist wound on bobbin, affords a delicately ornamental touch for Nylons, Chiffons and Paper Silk.

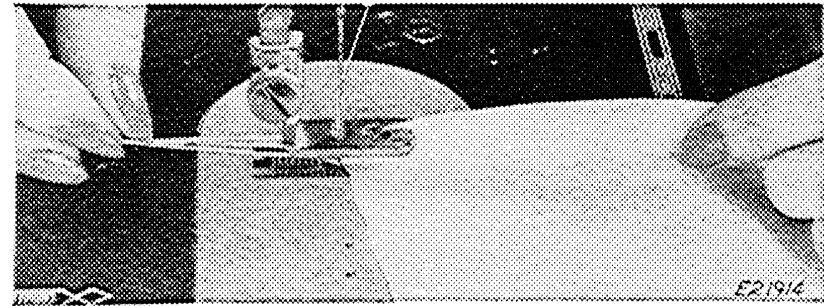

Fig. 87. Leading Raw Edge Into Scroll of Shell Hemmer

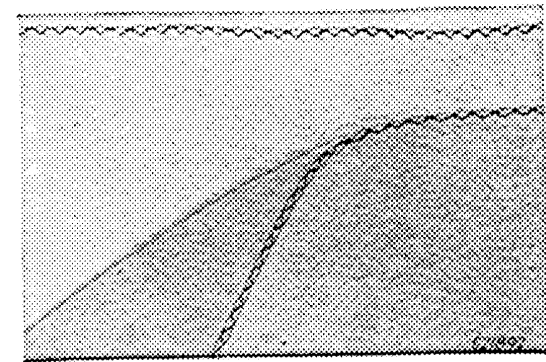
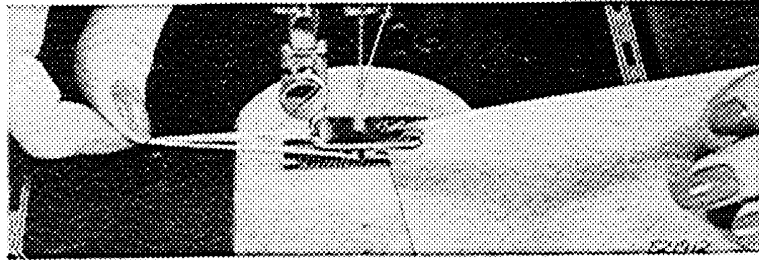

Fig. 89. Shell Stitched Hem For Sheers



*Fig. 90. Leading Raw Edge Into
Scroll of Hemmer*

Place raw edge, face down, over feed, and lower the Hemmer with right edge in line with raw edge to be hemmed. Take 1 or 2 stitches. Raise Hemmer, draw fabric back and cut off threads with Thread Cutter on Presser Bar. Holding the threads firmly with thumb and finger of right hand, lead raw edge into scroll of Hemmer by drawing on these threads until edge is fully wrapped around lead finger inside scroll of Hemmer. Then draw edge toward you until lead threads are in position under needle. Picking up needle and bobbin thread along with lead threads, lower the Hemmer, then lower the needle into fold of hem. Still holding all threads firmly for first few stitches, continue to hem, lifting raw edge slightly so that it feeds fully into mouth of Hemmer.

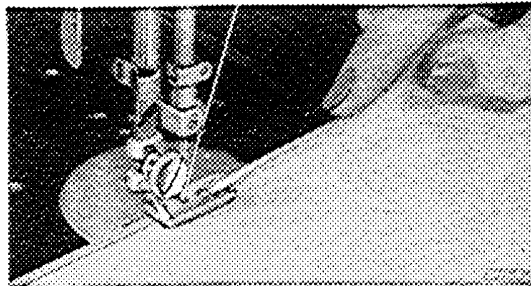
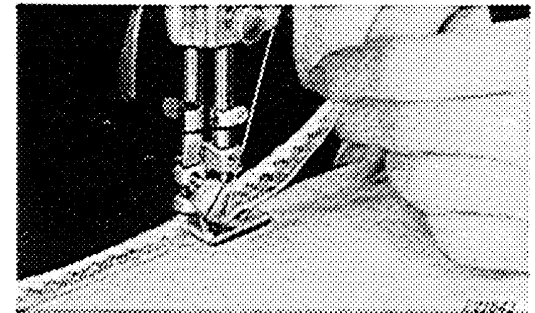

Fig. 91. Hemming

Lace Edging may be applied at same time by inserting edge of lace into open slot of Hemmer and back under its heel. Guide hem with right hand and lace with left hand, catching lace with needle as needle enters fold of hem. When applying lace, it is best to lay wrong side of garment against feed.



*Fig. 92. Applying Lace
While Hemming*

NARROW HEMS

The Narrow Hem, straight stitched, is a favorite for children's clothes, ruffled curtains and general utility wear.

Use **All-purpose Throat Plate**, or **Straight Stitching Throat Plate**, **Straight Stitching Hemmer 120842** (see page 20), **Central Needle Position**, **0 Bight**, **Stitch at #1 for about 25 stitches per inch.**

INVISIBLY APPLIED LACE

Invisibly Applied Lace may be French Hemmed, by inserting edge of lace beneath foot of Hemmer and within the fold as shown in **Fig. 93**. After stitching, hem is pressed to the wrong side, revealing lace edge (without stitches) on the right side of garment.

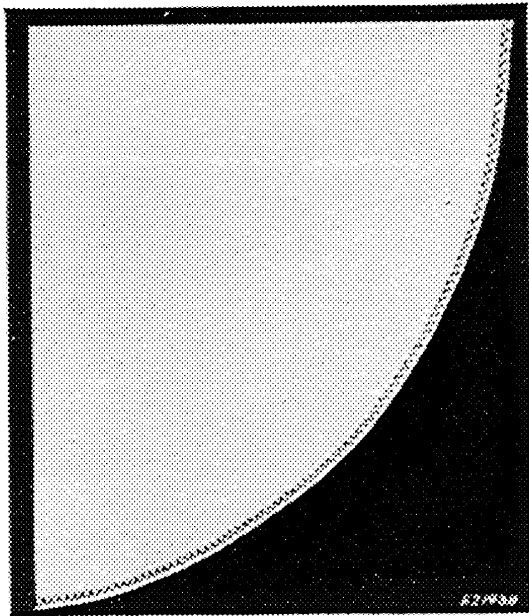

Fig. 94. Curved Edges Hemmed With Zigzag Stitch

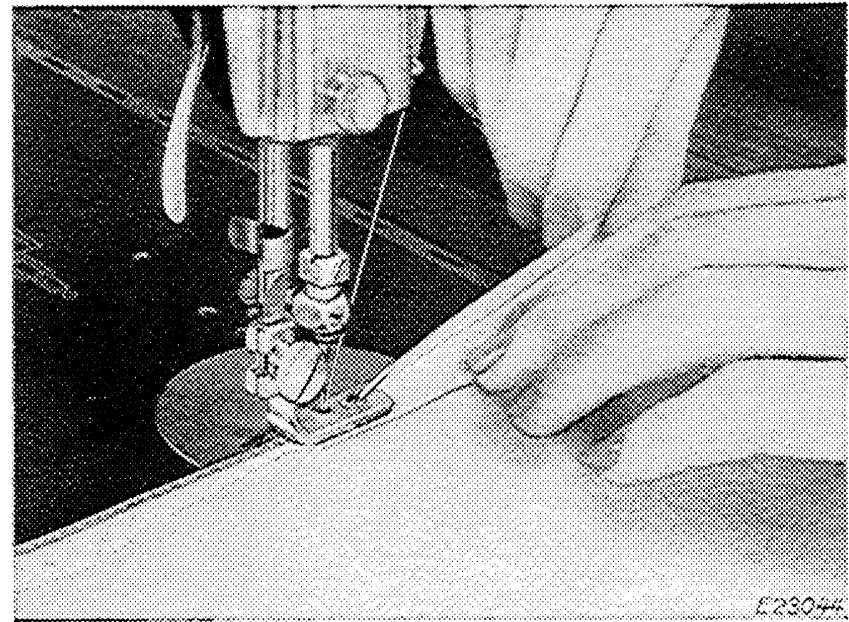

Fig. 93. French Hemmed Lace Edging

The elasticity of the zigzag stitch makes it especially good for hemming curved sections.

Use **All-purpose Throat Plate,**

Hemmer Foot 120842 (see page 20),

Central Needle Position,

2 Bight **ONLY,**

About #1½ Stitch setting for about 15 stitches per inch.

CAUTION: Any setting beyond 2 Bight will break the needle when using Narrow Hemmer 120842.

Follow same procedure for hemming as that given for straight stitched hems.

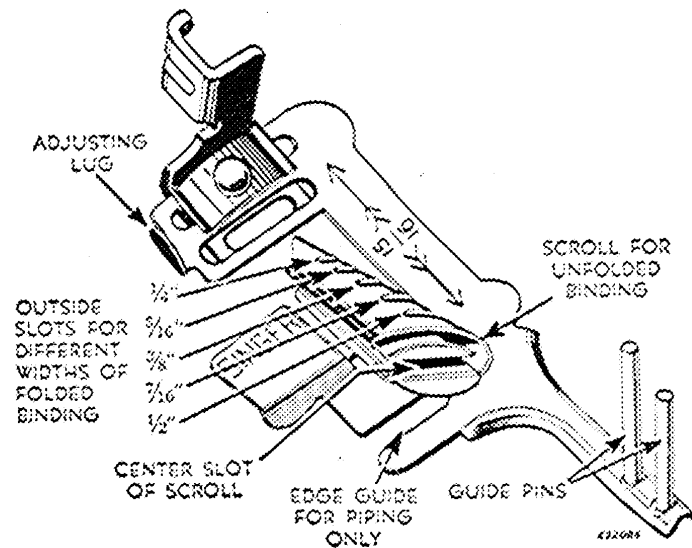

Fig. 95. Multi-slotted Binder

BIAS BOUND EDGES

The Multi-slotted Binder is provided with a wide throat to permit the use of zigzag stitching when using ready-folded Bias Binding. This affords a very elastic and durable flat finish for any type curve, scallop or patterned edge. The Binder will apply pre-folded bias binding in size 1, 2, 3, 4 and 5 ($\frac{1}{4}$ ", $\frac{5}{16}$ ", $\frac{3}{8}$ ", $\frac{7}{16}$ " and $\frac{1}{2}$ " in width respectively). Bindings are fed through slots of corresponding size in the binder scroll. To attach binding with zigzag stitching,

Use **All-purpose Throat Plate,**
Multi-slotted Binder,
Central Needle Position,

2 to 5 Bight (according to fabric and effect desired),

Stitch at #3 to #11 $\frac{1}{2}$ for 8 to 15 stitches per inch.

Cut binding to a long point from edges to center fold as shown in Fig. 97.

Inserting pointed end of binding into appropriate slot for its width, pull binding through until the evenly folded edges are under needle. Slip free length of binding between two upright pins which act as a guide for lightly feeding binding into Binder while it is being stitched. Place raw edge to be bound as far to right as it will go into mouth of scroll, as shown in Fig. 96, and stitch, allowing raw edge to pass freely through scroll, guiding fabric lightly from back of Binder and to the left, permitting unfinished edges to swing naturally into scroll of Binder.

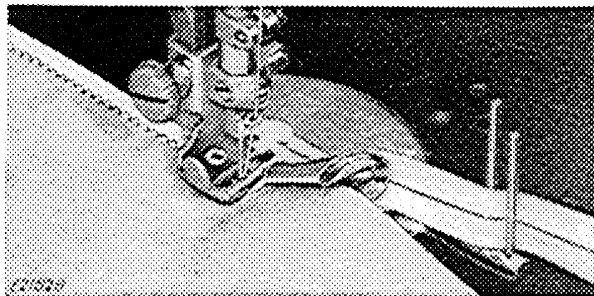

Fig. 96. Applying Binding to Garment

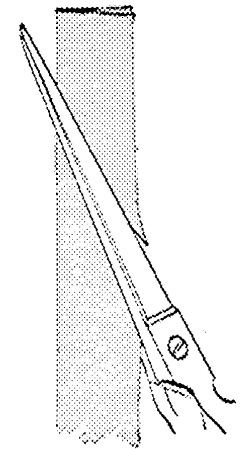

Fig. 97

Never pull binding while it is being fed through Binder as the Bias will stretch, making folds too narrow for needle to reach. Turn material slowly when binding around curves. The scroll can be adjusted to right or left for needle to catch edges of fold.

A great variety of effects may be obtained with the use of the Multi-slotted Binder by adjusting for different combinations of Bight and Stitch, by using contrasting color for thread, and by using different sizes of binding.

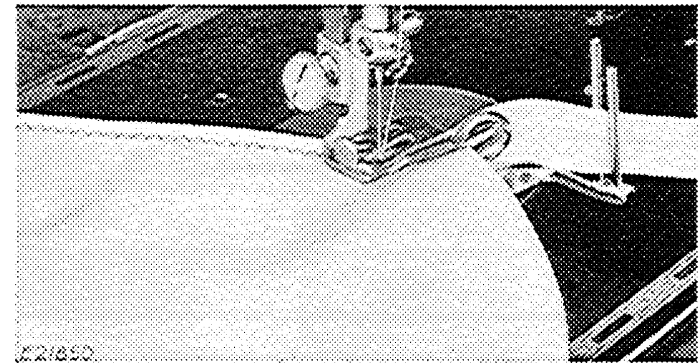

Fig. 98. Binding Curved Edge

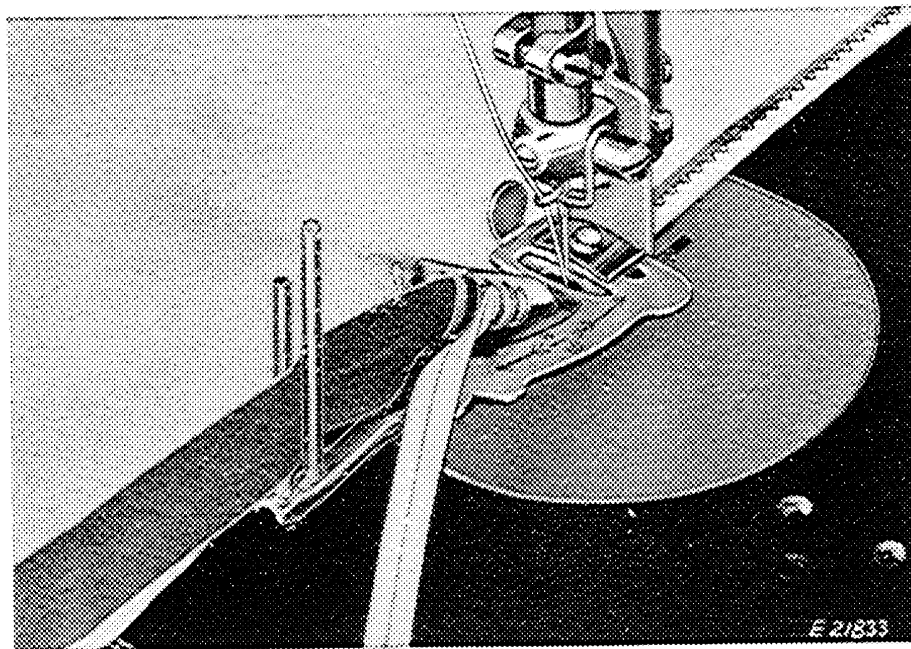

Fig. 99. Piped Binding

Piped binding is very effective when piping is in contrast to both the bound edge and the garment and when it is stitched in a contrasting color. For **Fig. 99** green bias binding $\#5$ ($1/2''$) was used in slot 5 to serve as piping; white bias binding $\#3$ ($3/8''$) was used in slot 3 to serve as binding; red silk was used for zigzag stitch set for 2 Bight and $\#2$ Stitch length, and fabric being bound was gray. The result was white bound edges, with green piping stitched in red, on gray fabric.

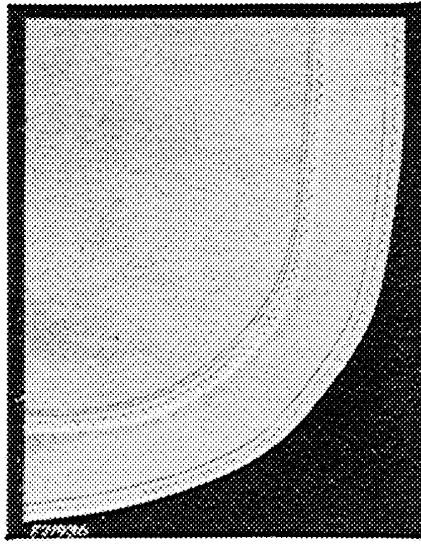

Fig. 100. French Folds Applied with Binder

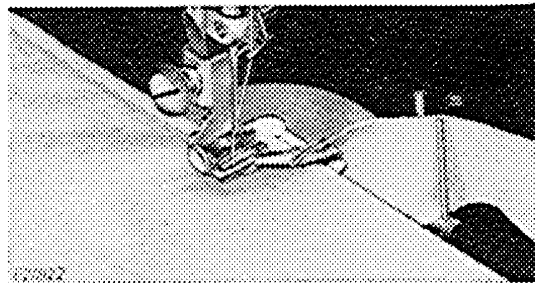

Fig. 101. Applying Unfolded Bias Binding With Straight Stitch

French Folds may be applied by guiding same binding through Binder over surface of garment about $\frac{1}{2}$ " from bound edge as shown in **Fig 100**.

Delicate fabrics that fray easily, like chiffon velvets, sheer metallics, etc., may have seam edges bound with Nylon net. Cut net into $\frac{1}{2}$ " wide strips and insert, **unfolded**, into slot 5 of Binder.

Use Central Needle Position,

2 Bight,

$\neq 1$ Stitch setting.

Feed seam edges into Binder with napped or right side up. This will ensure against fraying without adding bulk.

Self Fabric Bias Binding should be cut $1\frac{5}{16}$ " wide on the true bias. Insert this unfolded binding directly into two folds of scroll as shown in **Fig. 101** and draw it back folded by the scroll, under the Binder.

Adjust position of scroll so needle enters folded edge of binding above and below garment, lower Binder, and stitch. If preferred, a straight stitch may be employed for binding instead of zigzag stitch. For straight stitching, set Bight Lever at 0. All other operations are same as for binding done with zigzag stitches.

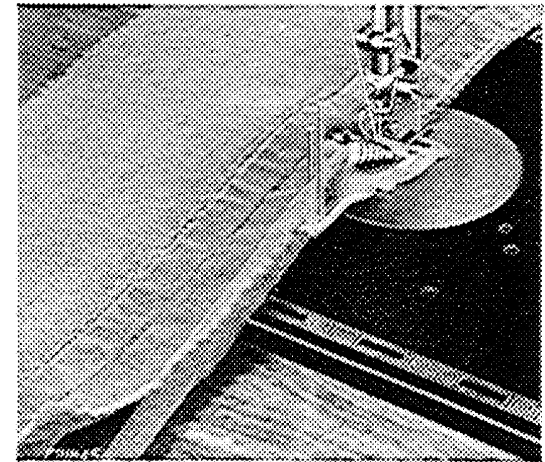
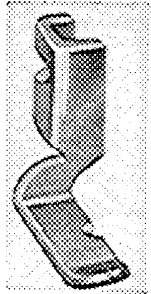
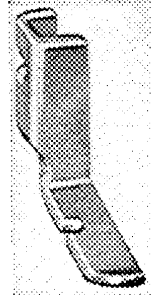

Fig. 102. Net Bound Seams For Velvets or Sheer Metallics



*Fig. 103. Cording
Foot (left toe)
160845*



*Fig. 104. Cording
Foot (right toe)
160846*

CORDED EDGES, WITH FABRIC COVERED CORD

Use **All-purpose Throat Plate**, or
Straight Stitching Throat Plate,
Central Needle Position,
0 Bight and Stitch at ± 2 .

Cording Foot (left toe) 160845 to cover
cord. **Cording Foot (right toe) 160846** to
insert cord.

Cut Bias Strips twice width of seam allowance plus cir-
cumference width of cord. Fold bias strip over cord with

raw edges even. Position needle close to cord but not into it, lower the Cording Foot (left toe) with the edge of foot close to cord but without crowding it, and stitch.

Replace Cording Foot (left toe) with Cording Foot (right toe) and machine baste covered cord to right side of garment with all seam edges even. Then place facing right side down over cord with seam edges even. Turning

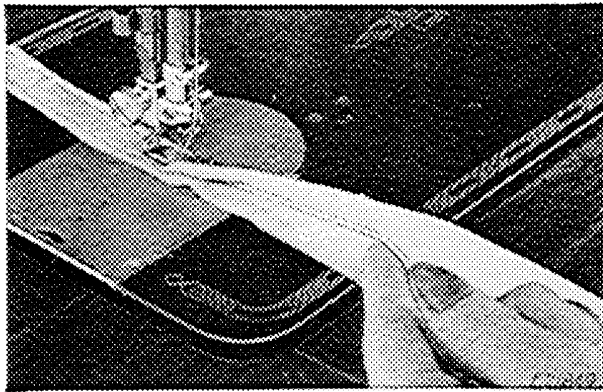

*Fig. 105. Cording Foot
(left toe) Covering Cord*

garment to wrong side with facing against feed and covered cord sandwiched between garment and facing, having all seam edges even, machine stitch together, crowding cord with edge of Cording Foot all along the way.

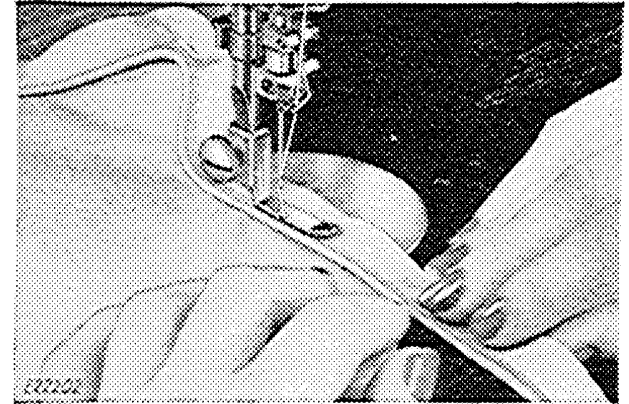

*Fig. 106. Machine Basting Covered
Cord To Garment*

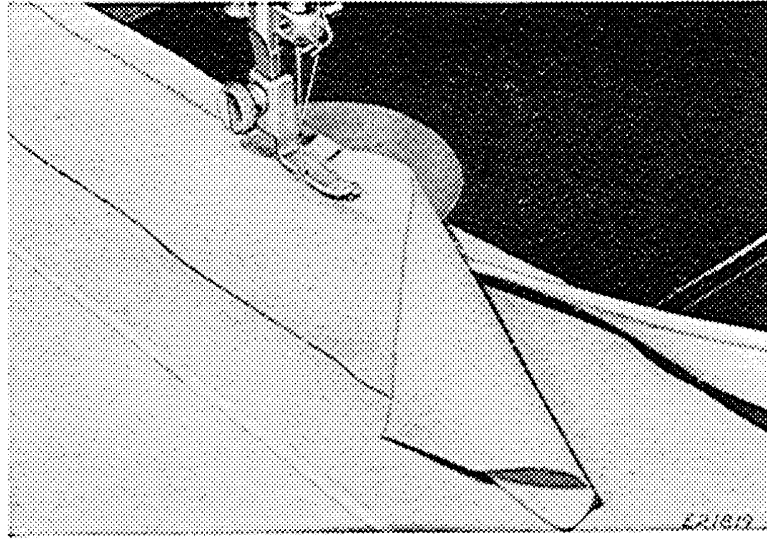

Fig. 107. Inserting Covered Cord Between Garment and Facing

Before turning, blend seams by cutting away seam allowance of cording edges to $\frac{1}{8}$ " from the stitching and cut garment and facing seams to within $\frac{1}{4}$ " from stitching to reduce the bulk.

When inserting covered cord along a curved edge, remember to ease seam allowance while stitching an inside curve and slightly stretch it while stitching an outside curve, keeping all seams even.

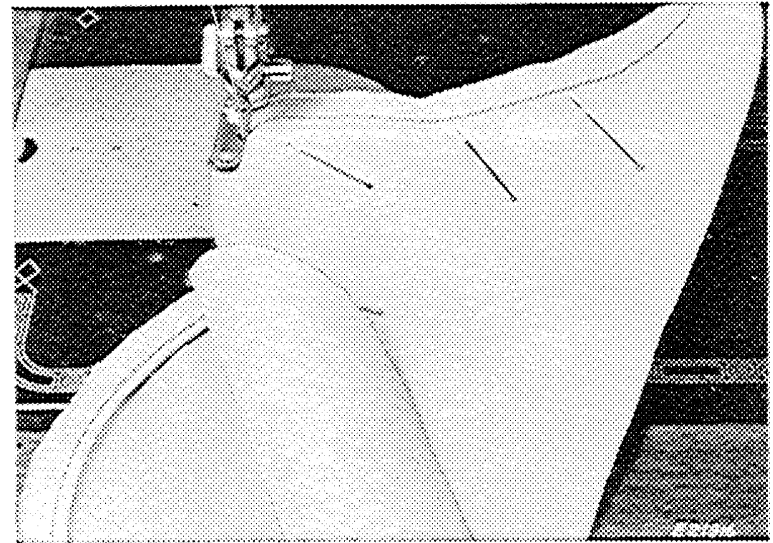

Fig. 108. Inserting Covered Cord Between Garment and Facing

Triple Corded Edges are effective in three colors, using the smallest size cord #9.

For cord laid nearest edge of garment, cut bias strip twice width of seam allowance plus circumference width of cord. For cord to be placed in center, cut bias strip **twice** width of seam allowance plus **twice** circumference width of cord. For cord laid furthest from edge of garment, cut bias strip **twice** width of seam allowance plus **three** times circumference width of cord.

With Cording Foot (left toe), stitch the covering over each cord, then, crowding cords against each other, with all seam edges even, machine baste together with Cord-

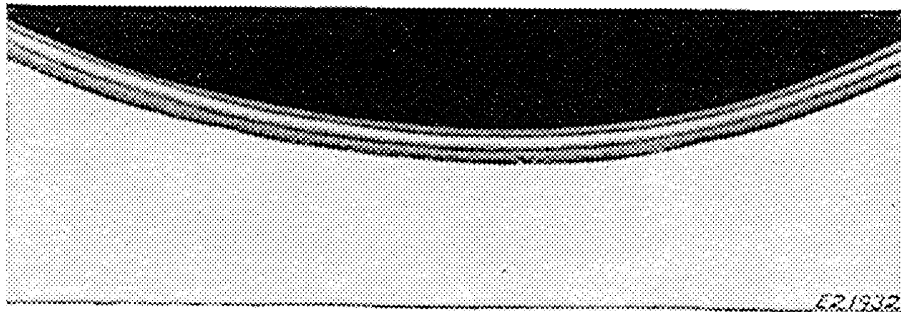

Fig. 110. Triple Covered Cord Edge

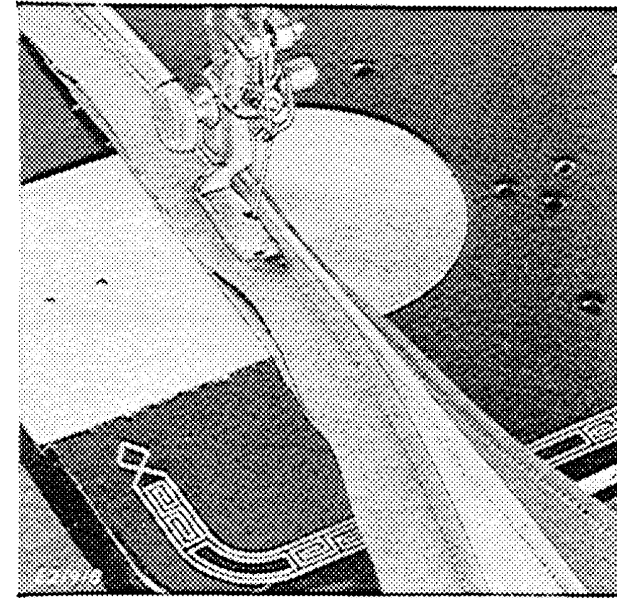

Fig. 109. Machine Basting Triple Covered Cords Together

ing Foot (left toe) close to cord to be laid nearest edge of garment. Replace Cording Foot (left toe) with Cording Foot (right toe) and insert triple covered cords between garment and facing, as instructed on **page 64**, crowding close to nearest covered cord with Cording Foot (right toe).

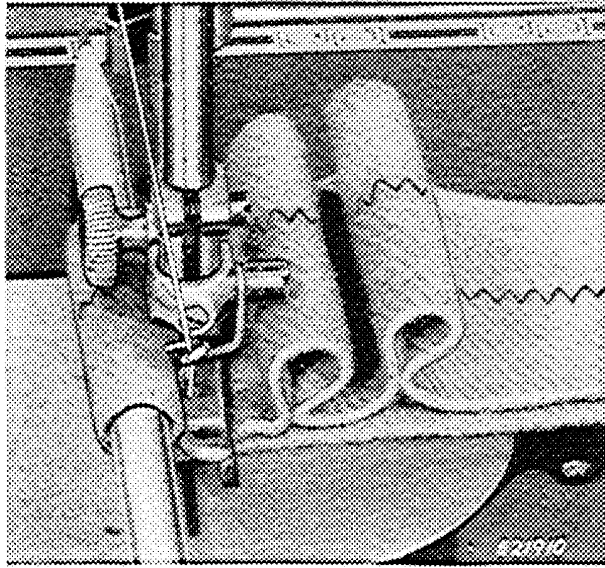

Fig. 111. Stitching Cartridge Pleats

In belt shown in **Figs. 111 and 112**, wool fabric interlined with Armo afforded the right stiffness. Cut the Armo interlining the size of finished belt, and cut the fabric twice the size plus $\frac{1}{4}$ " for ease. Machine baste the

CARTRIDGE PLEATS

Cartridge Pleats may be easily made with Cording Foot (right toe) by encircling a round lead pencil with the fabric and stitching close to it, with edge of Cording Foot crowding pencil. Remove pencil and repeat as close as completed pleat will permit. For smaller pleats, use an orangewood stick or a knitting needle. The stitching should begin and end with a back-tacking stitch. To back-tack, lift the stitch setting lever to its highest position for setting the stitch in reverse. (See **page 26**.) Cartridge pleats afford effective narrow trim for belts, bands or pockets.

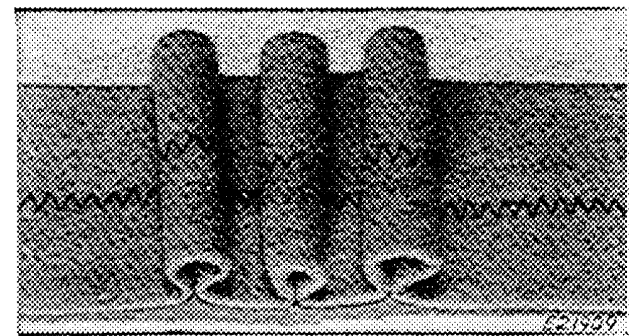

Fig. 112. Belt Finished With Cartridge Pleats

Armo interlining to the exact center of wool strip. Then, turning back the fabric in a soft fold, blind stitch each raw edge of the Armo to the fabric, following the procedure outlined on page 53.

Use **Cording Foot (right toe) 160846** (see Fig. 104, page 63),

All-purpose Throat Plate.

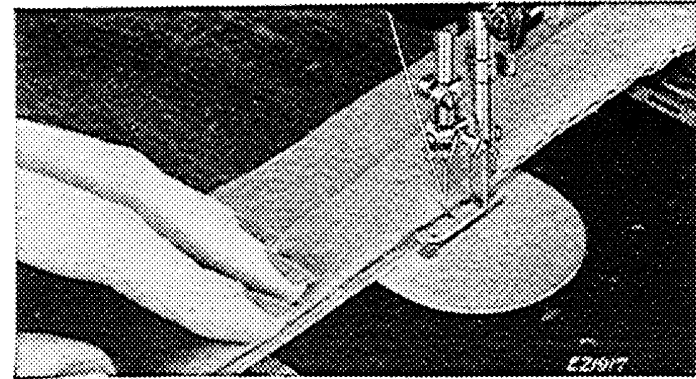

Fig. 113. Blind Stitching Armo Interlining to Belt

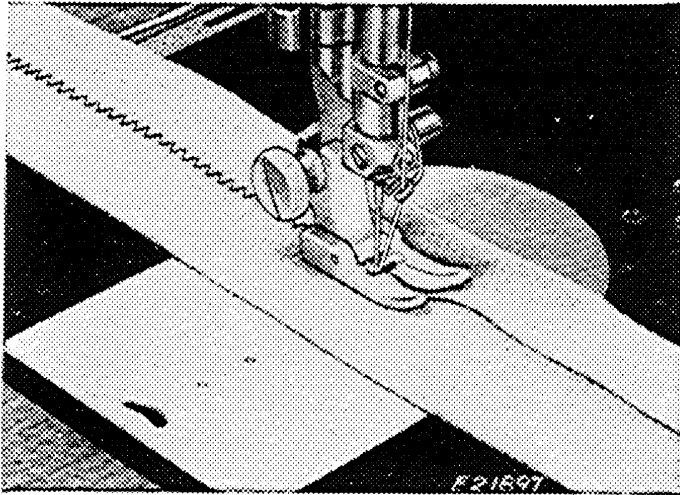
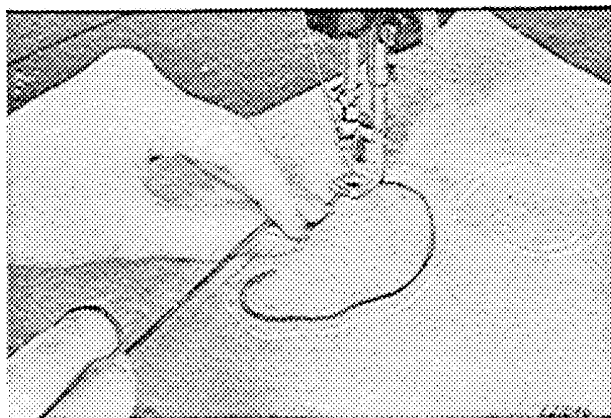

Fig. 114. Abutted Seam Edges Joined With Overlocking

Remove center basting, and laying the two raw edges of fabric together, right sides out so that they meet at center, follow the same procedure as outlined on page 41, using the **All-purpose Presser Foot 189646** (see page 22). Press with edges of seam abutting one another, for a perfectly flat finish. The belt is now ready for the Cartridge Pleats.



*Fig. 115. Applying Raised Braiding
With Embroidery Foot 189651*

soutache braid, ready for right swing, lower Embroidery Foot and apply stitches, from center of braid, **over one side only**, throughout the

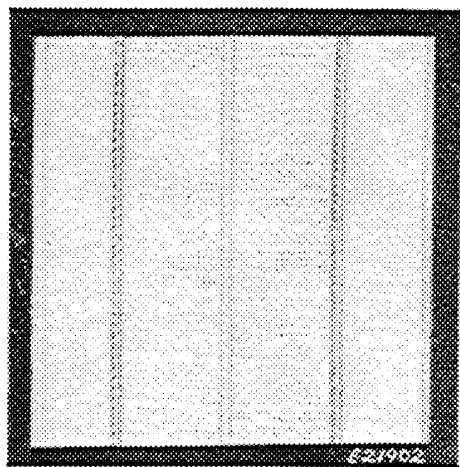

*Fig. 117. Straight Stitch
Flat Braiding*

BRAIDING

For Raised Braiding,

Use **All-purpose Throat Plate,**

Embroidery Foot 189651 (see page 23),

Soutache Braid, Central Needle Position, 1 Bight,
Stitch Setting at $\# \frac{1}{2}$ for about 27 stitches per inch.

Light tensions, fine needle and silk thread.

Choose design with flowing, open lines avoiding crossed lines where possible. Stamp design on face of garment. Position needle in center of soutache braid, ready for right swing, lower Embroidery Foot and apply stitches, from center of braid, **over one side only**, throughout the design. When completed, cut braid about 3" beyond last stitch and draw ends of braid through to underside by puncturing a tiny hole in fabric with a stiletto or coarse needle. Then, taking a few stitches with a hand needle in end of braid, pass hand needle through puncture carrying braid with it. Turning braid over stitches of design on underside, fasten it down with hand stitching for about an inch, and cut surplus braid away. Turn fabric over to right side and raise free edge of braid by passing blade of very small screwdriver under it. Braiding will then have the curled look of fine hand braiding. Soutache may also be applied flat, where desired, by using straight stitching applied directly through center channel. For this effect.

Use either **All-purpose Throat Plate,** or **Straight Stitching Throat Plate, Embroidery Foot 189651,** Central Needle Position, 0 Bight, Stitch Setting at $\# \frac{1}{2}$ for 27 stitches per inch, Fine needle $\# 11$, and silk thread.

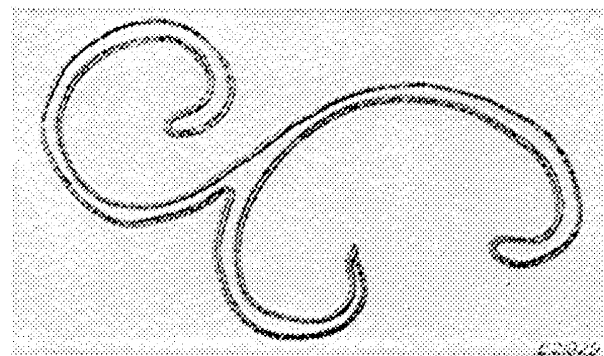

Fig. 116. Raised Soutache Braiding

RIC-RAC BRAIDING

Use **All-purpose Throat Plate**,
Embroidery Foot 189651 (see page 23), which
 accommodates braid through channel on its under-
 side.

Central Needle Position,
 2 Bight and #2½ Stitch Setting,
 Fine needle #11 and silk thread.

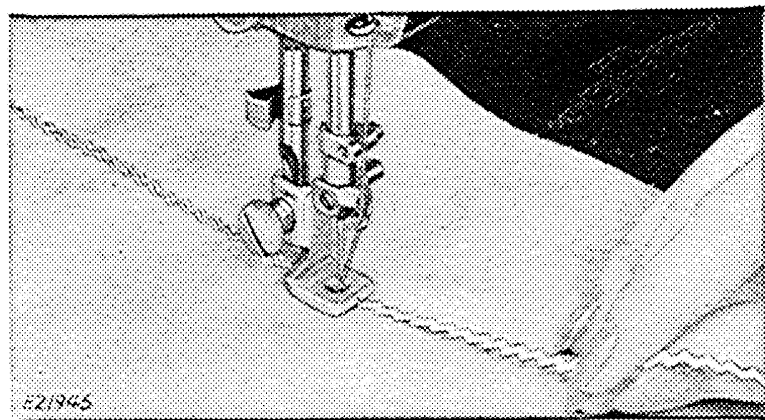

Fig. 119. Ric-rac Braiding Following Scallops

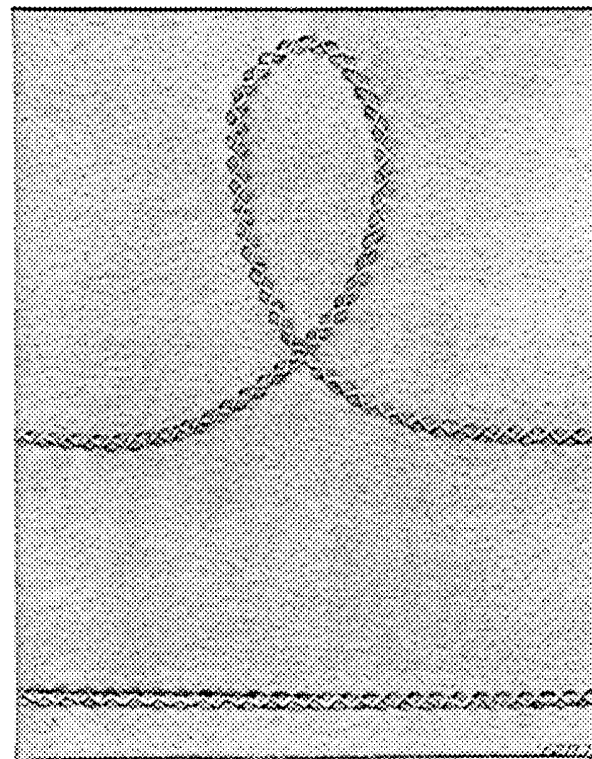

Fig. 118. Ric-rac Braiding With Enclosed Scallops

Ric-rac Braiding may be applied with stitches enclosing each scallop or through center following scallop. When applied with contrasting colored silk, embroidered effect is enhanced.

CORDED BRAIDING

Use **All-purpose Throat Plate,**
All-purpose Presser Foot 105069,
 Central Needle Position,
 3 Bight,
 Stitch Setting at #2.

Corded Braiding may be used for both finishing of edges and for ornamentation, making it particularly effective for cut-out design as shown in **Fig 121.**

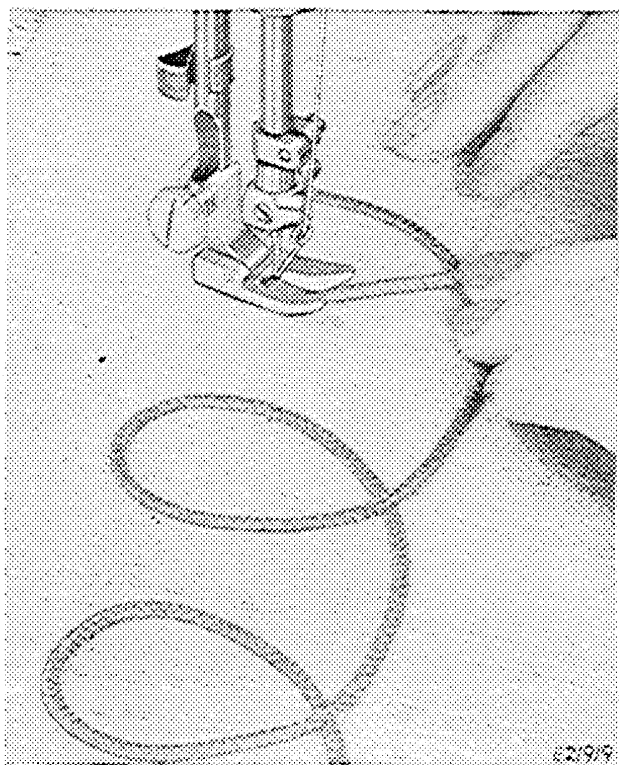

*Fig. 120. Applying Corded Braiding
 With All-purpose Presser Foot
 105069*

After braiding the design, draw the braid through to the underside as described for soutache braiding (see **page 68**). Then, with embroidery scissors, cut away surplus edge close to stitching, repeating inside each circle of design.

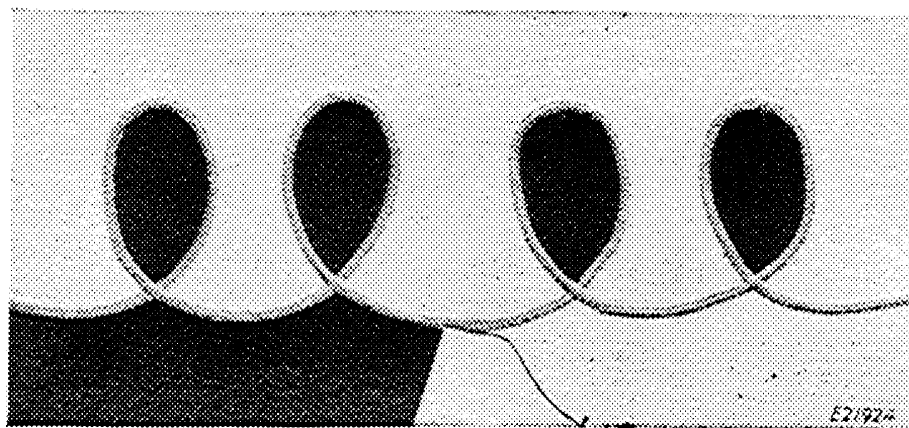

Fig. 121. Corded Braiding in Cut-out Design

THREAD CORDING

Thread Cording, so much in demand for children's wear because of its daintiness and durability, may be done in matching or contrasting color, in single or multiple rows.

Use **All-purpose Throat Plate,**
Appliqué Foot 189650,
 Central Needle Position,
 1 Bight.
 Stitch Setting at # $\frac{1}{2}$.
 #11 Needle and silk thread.
 Light tension.

The thread to be covered may be same as used for needle and bobbin or, it may be heavy duty thread, fine gimp or #8 Pearl Cotton. Metallic thread is also used for women's wear or accessories.

It is usually best to match color of filler thread with covering threads, but contrasting color may also be used for variation of treatment, particularly if filler thread be gimp, pearl cotton or metallic.

Insert filler thread in eye of Cord Covering Appliqué Foot, using tailor's wax to point the

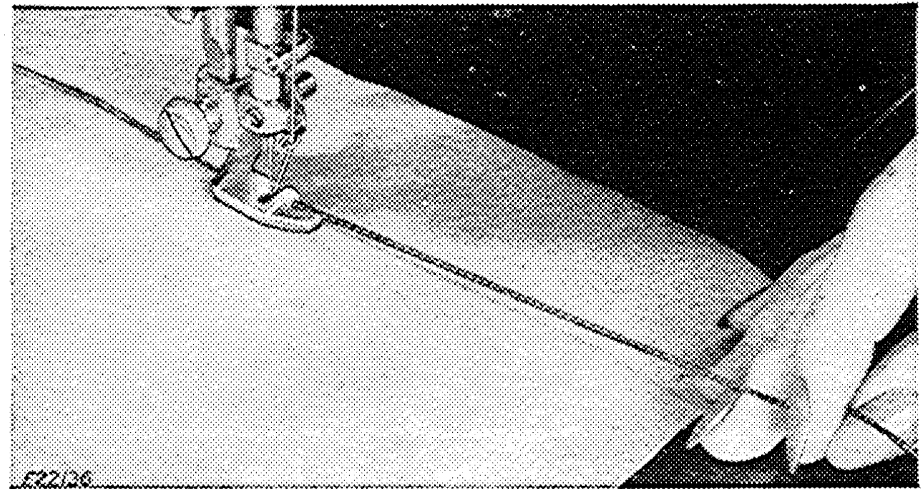

Fig. 122. Thread Cording With Appliqué Foot 189650

end of gimp or pearl cotton. Position needle at point to be corded and lower the foot, covering filler thread with closely spaced stitches. For contrasting effect, follow same procedure but lengthen stitch setting according to effect desired.

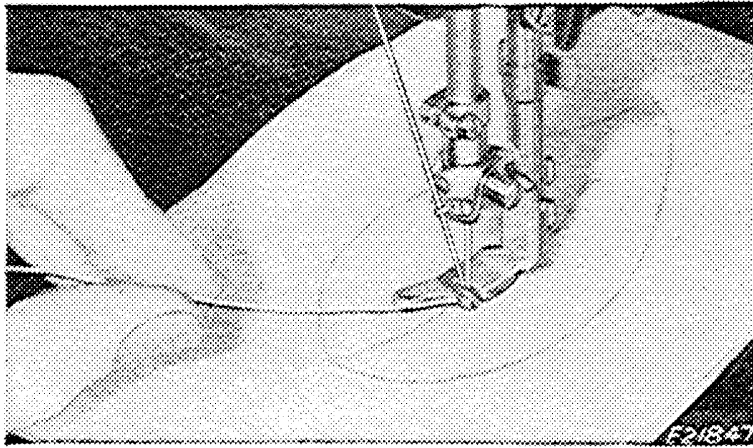

Fig. 123. Covering Wire For Stiffening

Insert wire into eye of Appliqué Foot 189650, as a filler thread, and cover it with very closely spaced stitches using Stitch setting of $\# \frac{1}{2}$ or slightly less, all other settings being same as for Thread Cording ([page 71](#)). When wire has been completely covered with tiny stitches, raw edge of fabric may be cut away close to stitching.

Collar in [Fig. 124](#) illustrates use of wire on edges as well as center spine of each petal. The petals may be softly flared into any shape desired, the fine wire being flexible enough to take, and hold, any position.

WIRED EDGES

For permanent flare or shaping of soft fabrics, wired edges may be accomplished in same way as for Thread Cording except that $\# 32$ fine galvanized wire (obtainable by the spool in hardware stores) is used instead of filler thread. It is important that **galvanized wire** be used since this type of wire will not rust or stain in laundering or dry cleaning.

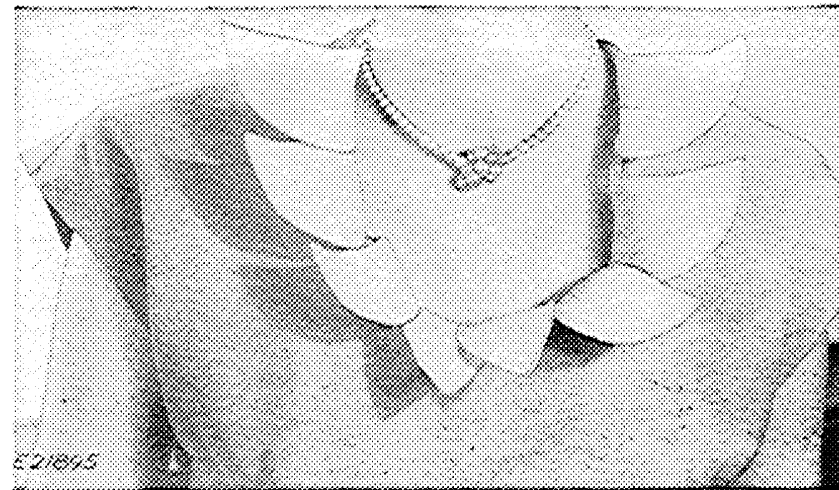

Fig. 124. Wired Edge and Spine Applied to Petal Collar

THE RUFFLER

Ruffling, Puffing and Pleating are best accomplished with the Ruffler, using straight stitching.

Use Straight Stitching Throat Plate,
Ruffler 120598,

Central Needle Position,

0 Bight,

Stitch setting for length according to fullness desired.

PRINCIPAL PARTS OF RUFFLER

A—Foot—attaches ruffler to presser bar.

B—Fork Arm—straddles needle clamp.

C—Adjusting Screw—regulates fullness of gathers.

D—Projection—engages slots in adjusting lever.

E—Adjusting Lever—sets Ruffler for gathers or pleats.

F—Adjusting Finger—regulates depth or size of pleats.

G—Separator and Seam Guides—separates ruffle strip from fabric and facing—guides seam edges evenly.

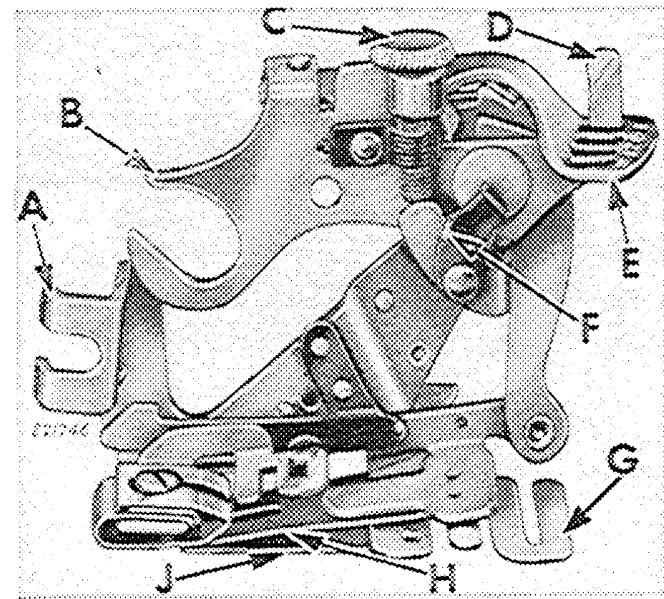

Fig. 125. Principal Parts of Ruffler

H—Ruffling Blade—the upper, blue steel blade with teeth.

J—Separator Blade—lower blue blade keeps Ruffling Blade Teeth separate from Feed Dog Teeth.

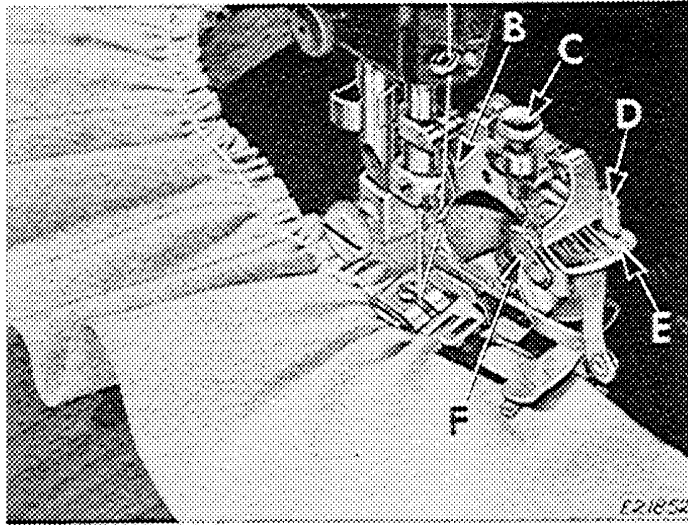

Fig. 126. Gathering With Ruffler

blue blades and under separator guide (**Line 2, Fig 127**). Draw material slightly back of needle, lower presser bar and commence to sew. For fine gathering, turn adjusting screw **C** upward to shorten stroke. Set machine for a shorter stitch. For full gathering, turn adjusting screw **C** downward to lengthen stroke. Set the machine for a longer stitch.

To Attach Ruffler, raise needle to its highest point, loosen presser foot thumb screw and attach ruffler in place of presser foot, at same time placing fork arm **B** astride needle clamp. See that needle enters center of needle hole in ruffler.

To Adjust Ruffler for Gathering, swing adjusting finger **F** away from needle. Raise adjusting lever **E** and move it until projection **D** can be entered in slot marked "I". Insert material to be ruffled between two

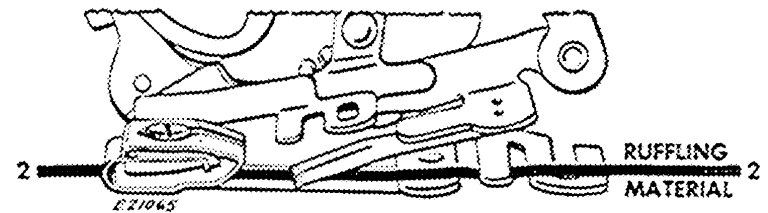

Fig. 127. Correct Position for Material to be Ruffled

To Make a Ruffle and Sew it to a Garment in One Operation

Insert material to be ruffled between two blue blades and under separator guide (Line 2, Fig. 128).

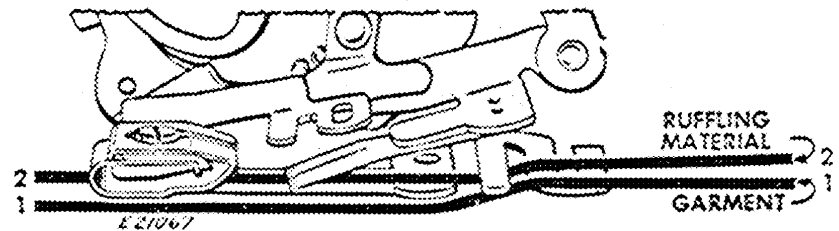

Fig. 128. Correct Positions for Materials

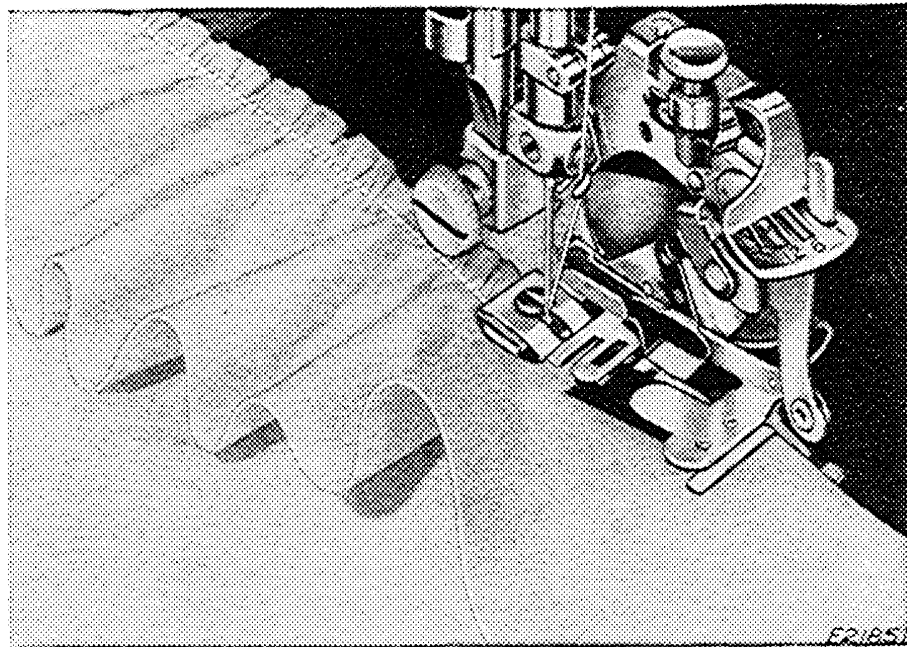

Fig. 129. Making a Ruffle and Attaching It in One Operation

Place material to which ruffle is to be attached under separator blade and under separator guide (Line 1, Fig. 128). Proceed the same as for plain gathering.

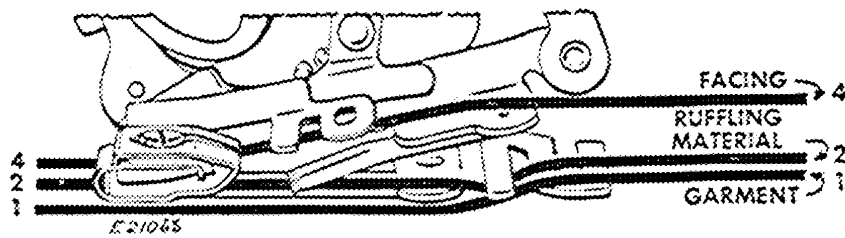

Fig. 130. Correct Positions for Materials

Place facing material over upper blue blade (**Line 4, Fig. 130**). If facing is to be on **right side** of garment, place wrong sides of garment and ruffle together. If facing is to be on **wrong side**, place right sides of garment and ruffle together.

To Make a Ruffle and Attach it with a Facing in One Operation

Insert material to be ruffled between two blue blades and under separator guide (**Line 2, Fig. 130**). Place material to which ruffle is to be attached under separator blade and under separator guide (**Line 1, Fig. 130**).

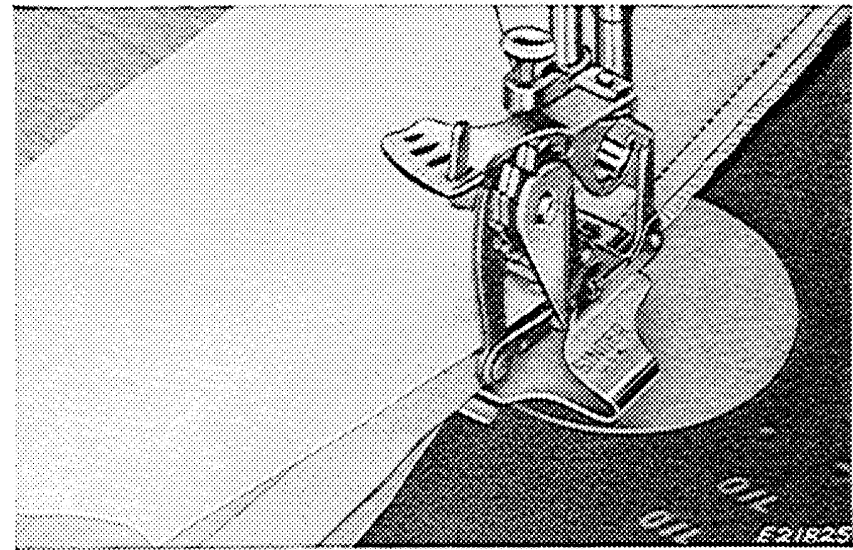

Fig. 131. Making a Ruffle and Attaching It with a Facing in One Operation

To Pipe a Ruffle

Insert material to be ruffled between two blue blades from the right (Line 3, Fig. 132). This material must not exceed $1\frac{1}{4}$ " in width.

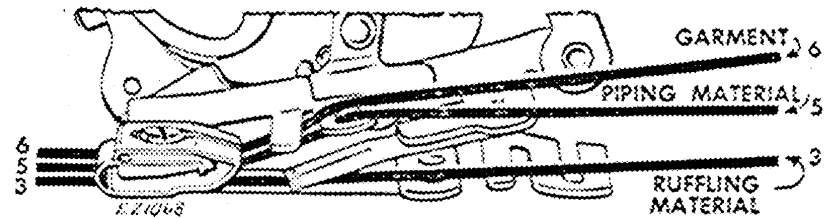

Fig. 132. Correct Positions for Materials

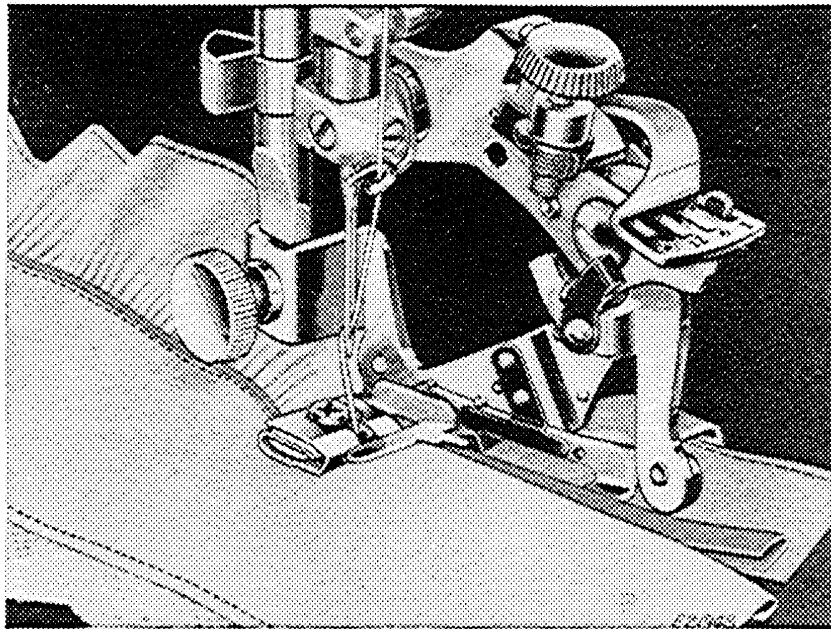

Fig. 133. Piping a Ruffle

The piping material is usually cut on the bias and it should be about $\frac{1}{4}$ " wide when folded in center. Place piping material in ruffler, following Line 5, Fig. 132 with folded edge of piping to the right. Fold edge of material to which piping and ruffling are to be attached and insert it in ruffler from the left, following Line 6, Fig. 132.

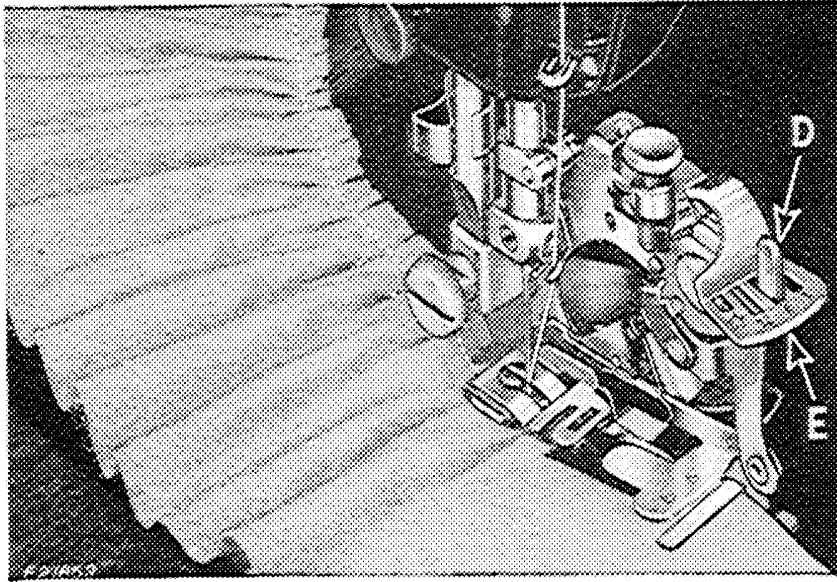

Fig. 134. Pleating with Ruffler

To increase width of pleat, move adjusting finger **F** back toward needle and turn adjusting screw **C** downward. To make a smaller pleat, turn adjusting screw **C** upward. The distance between pleats is regulated by length of stitch.

To Adjust Ruffler for Pleating

Raise adjusting lever **E** and move it until projection **D** can be entered in slot marked "6". The ruffler will then pleat once every 6 stitches. To pleat once every 12 stitches, have projection **D** enter slot "12" in adjusting lever **E**. Insert material to be pleated between two blue blades and under the separator guide (Line 2, Fig. 135).

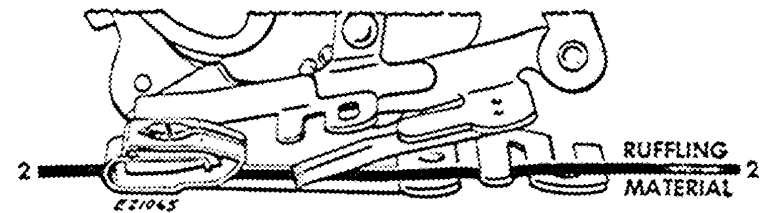

Fig. 135. Correct Position for Material

To Adjust Ruffler for Group Pleating

To make the space between the groups of pleats, raise adjusting lever **E** and move it until projection **D** can be entered in small slot indicated by star on adjusting lever **E**. The ruffler will then stop pleating and plain stitching will be made.

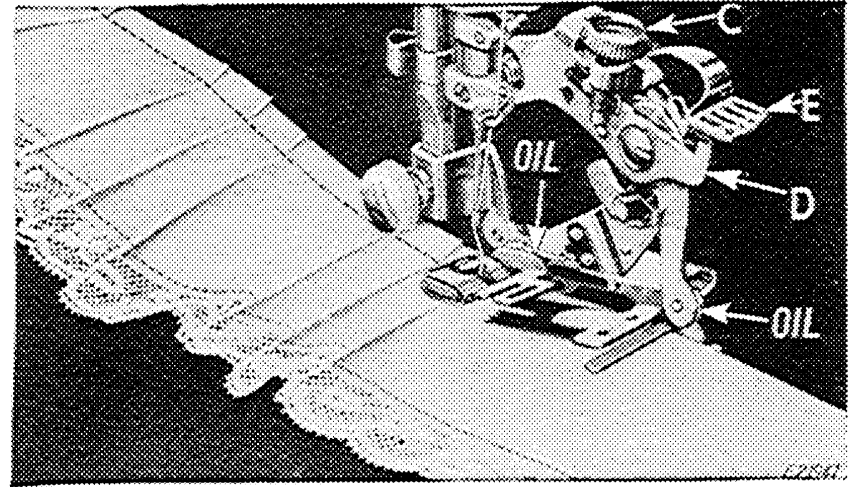

Fig. 136. Group Pleating with Ruffler

When desired space is made, set projection **D** in either of slots "6" or "12". Insert material to be pleated between two blue blades and under separator guide (Line 2, Fig. 137).

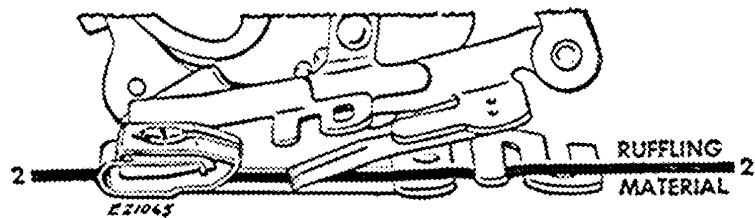

Fig. 137. Correct Position of Material

To Oil The Ruffler

Occasionally apply a drop of oil to working parts of ruffler at places indicated in **Fig. 136**.

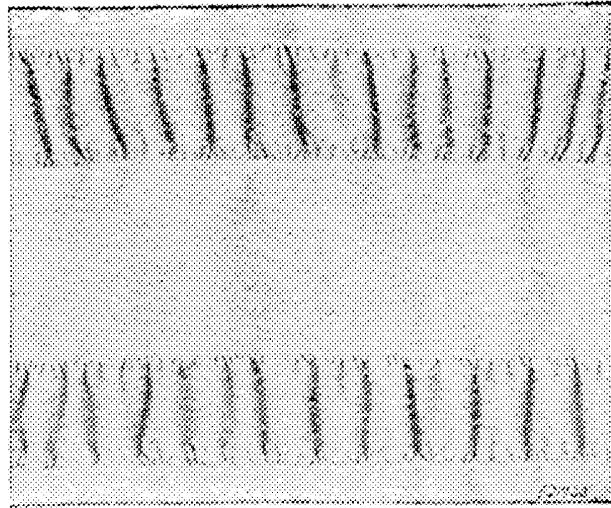

Fig. 138. Puffing Inserted Between Bands with the Ruffler

time it is inserted between garment and facing. Use ribbon 1" wide or cut linen strips $1\frac{1}{8}$ " wide. Folding linen strip in half, press with a hot iron. Insert ribbon or linen strip into Ruffler with garment below and facing above it as shown on page 76. Then, with projection in slot "6", adjusting screw C turned down as far as it will go, adjusting finger F turned back in position under screw C and Stitch set at $\frac{1}{2}$, proceed to pleat, keeping all seam edges even. Turn to right side to reveal the closely spaced, round edged pleats called Gophering or Ruching Pleats.

Puffing is made by inserting narrow bands of self or contrasting fabric into garment with Ruffler. The narrow strip for puffing is first attached to garment while it is being gathered, in same manner as instructed on page 75 for making and attaching a ruffle. **Opposite** edge of puffing strip is then inserted between blades of Ruffler and another band attached beneath it while it is being gathered. This process is repeated for as many bands as desired, the Ruffler keeping the gathers balanced and permanently stroked to produce the puffed effect.

Gophering or Round Pleating of narrow fabric for ruchings may be easily accomplished with Ruffler at same

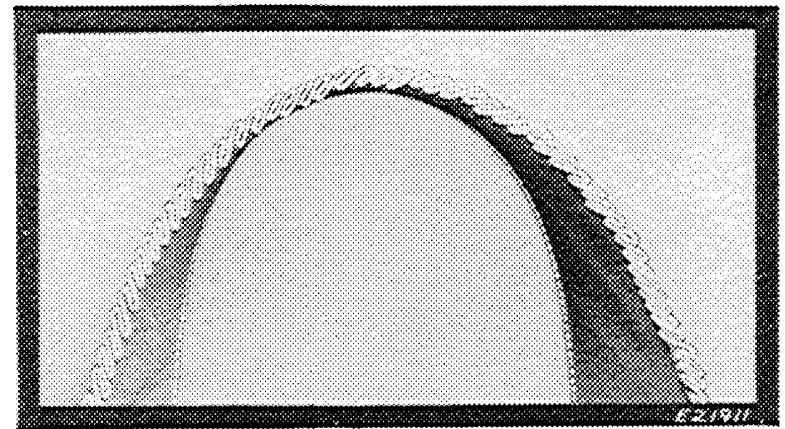

Fig. 139. Gophering or Round Pleating Made with Ruffler

FRINGED EDGES

Use **All-purpose Throat Plate**,
All-purpose Presser Foot 105069 (see page 22),
Left Needle Position,
2 Bight,
 Stitch setting at #1½.

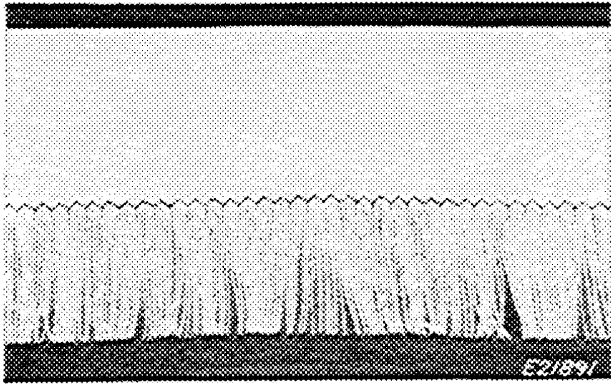

Fig. 141. Fringed Edges

Wide Hemstitching is done in same manner as Fringed Edges, except that threads are drawn from body of fabric beginning with two threads drawn the distance apart that the hemstitching is desired. Stitch along these drawn threads and position needle as before. When first line is completed, turn fabric around to begin second line directly opposite last stitch taken in first line. Be careful to match opposite swing of stitches. Then draw remaining center threads from fabric between the rows of stitching.

Draw a thread the distance from the raw edge of fabric that you have determined should be the depth of the fringe. Positioning the needle on line of drawn thread, lower All-purpose Presser Foot and stitch along this line. Beginning at raw edge, draw out thread by thread up to the stitched line.

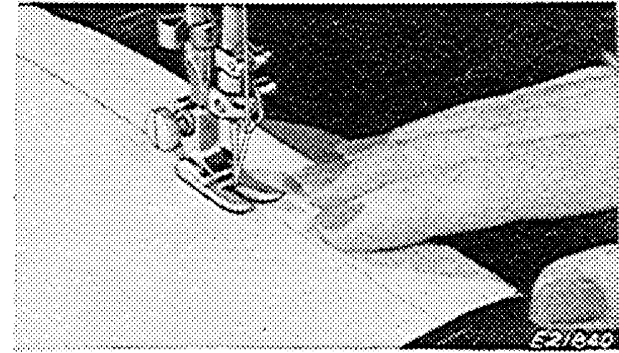

Fig. 140. Following Drawn Thread with All-purpose Presser Foot 105069

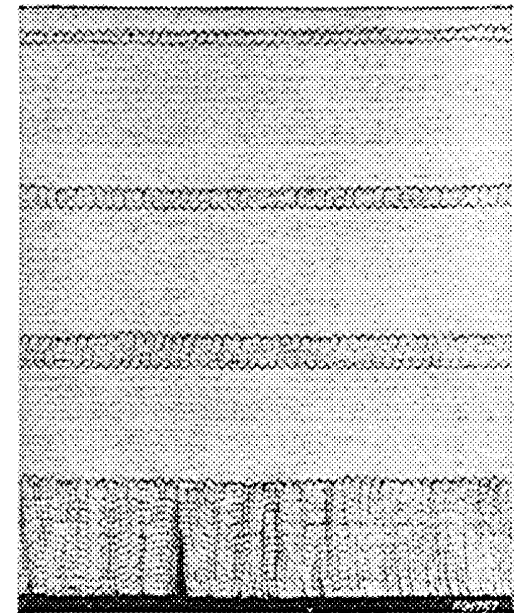

Fig. 142. Wide Hemstitching

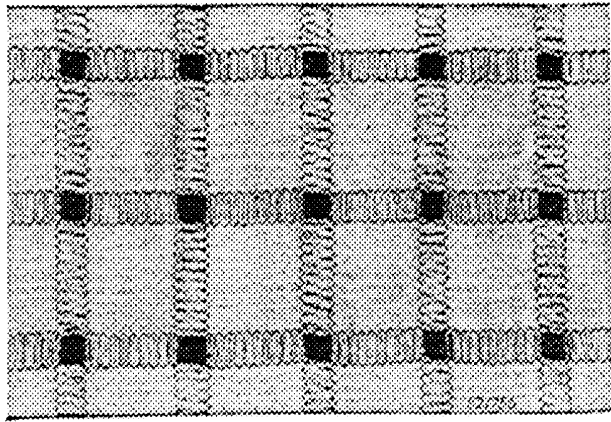

Fig. 143. Patterned Wide Hemstitching

Use #9 Needle, silk thread, a very light upper tension, tight lower tension and, **most important**, the **Pressure** on Presser Foot must be set as light as possible so that fabric will feed without resistance (see **page 27**).

Owing to depth of Bight for scallop, this work is best done over two thicknesses of material. When used as a hem border, turn up a hem allowance twice depth desired: that is, if bordered hem is to be 2" deep, turn up 4", baste and press. Stamp or trace scallops on right side of fabric at least 2" from fold. When scallops are to finish a single thickness, stamp or trace scallops at least 2" from raw edge and underlay fabric with crinoline or organdy. When stitching, material must remain straight at all times in line with the feed. Scallops must be followed without turning, but by lightly moving the work to right or left in rhythm with needle. This will maintain parallel stitches, evenly spaced, automatically producing the effect of a narrower stitch at point of scallop and widening to full depth at the arc.

Wide hemstitching may be developed in a pattern based on lengthwise and crosswise threads, as shown in **Fig. 143**, but all stitching should be completed before drawing center threads.

SATIN STITCHED SCALLOPS

Finely corded edges on satin stitched scallops provide a beautiful and durable edge finish for household linens as well as for lingerie and accessories. For the scallops,

Use **All-purpose Throat Plate**,
Satin Stitch Presser Foot 189649 (see **page 22**),
Right Needle Position.
5 Bight, almost 0 Stitch setting.

CAUTION: Whenever a very wide zigzag bight is used, paper backing must be placed under the fabric to prevent gathering or puckering of the material.

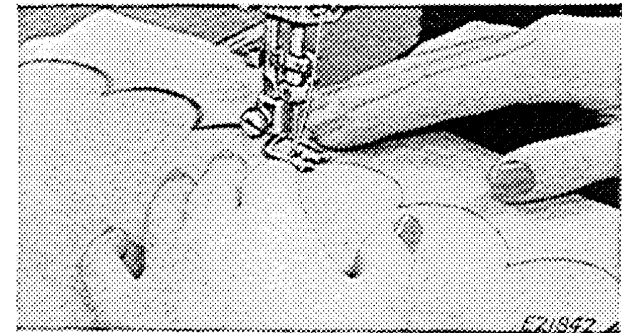

Fig. 144. Stitching Scallops

TO CORD THE SCALLOPS

Use **Embroidery Foot 189651** (see **page 23**) and change Bight to $\#1$. Replace the **Pressure** on presser foot to normal. Use Heavy Duty Thread as a filler.

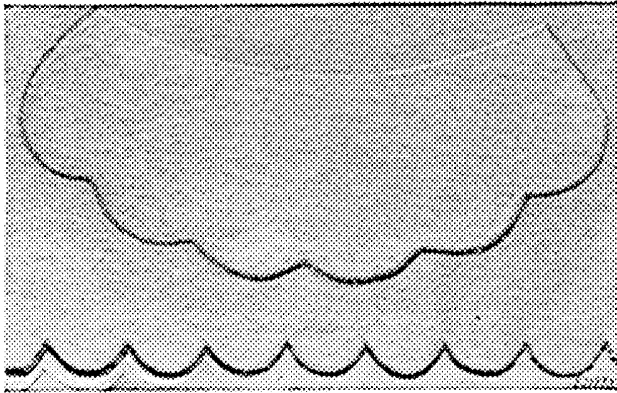

Fig. 146. Scallop Bordered Hem

If scallops are to border a hem, repeat cording inside curve of scallop, and cut away surplus hem edge from wrong side, cutting close to inside cording stitches with sharp embroidery scissors. If scallops are to form edge, cut away surplus border close to cording stitches on **outside** of scallop, from wrong side of fabric. Also cut away foundation crinoline or organdy.

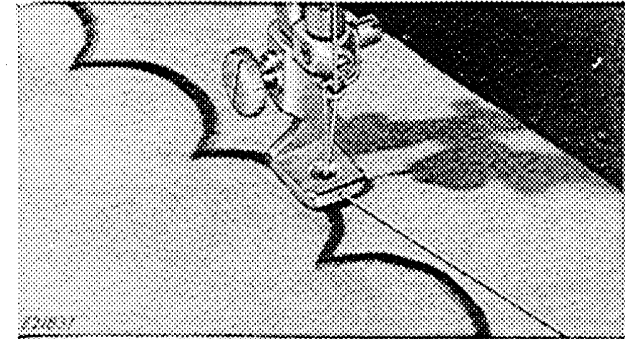

Fig. 145. Cording the Scallops

Threading Heavy Duty Thread into eye in toe of Embroidery Foot, carry it through and under foot. Position needle close to edge of scallop, lower Embroidery Foot and trace close to scallop, covering filler thread with tiny lateral stitches crowded against scallops all along the way.

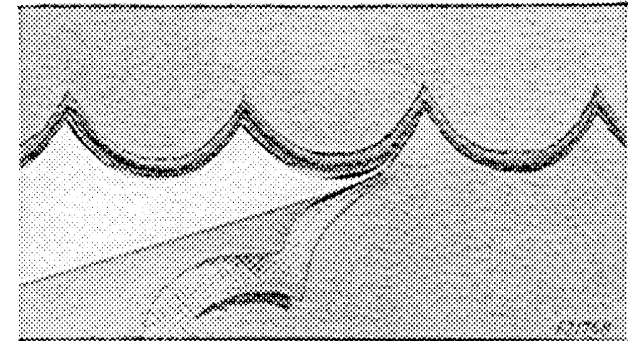

Fig. 147. Scalloped Edge

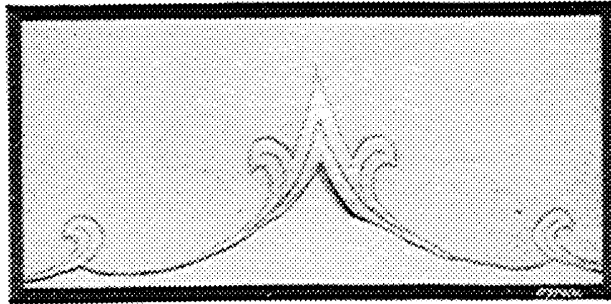

Fig. 148. Satin Appliquéd to Chiffon in Border Design

Overlay chiffon with a strip of satin and underlay with crinoline or organdy, cutting both 2" wider than maximum depth of border design. Baste into position across top and bottom of bands. Stamp or trace outline of design on right side of satin. Center design with Walls of Troy stitch (see **Line 7, pages 34 and 35**), setting Bight and Intervals in proportion to outline. For design in **Fig. 148**, machine was set for 2 Bight. Central Needle Position was alternated with Left Needle Position every 5 stitches.

For outline, use **Satin Stitch Foot 189649** (see page 22), Central Needle Position, 2 Bight, Almost 0 Stitch setting.

After completing the outline, use small sharp embroidery scissors to cut away surplus lower edges of satin, organdy and chiffon, cutting from wrong side of fabric. Then cut away surplus satin and organdy **above** design, very close to stitches, and press from wrong side of fabric.

Satin Appliquéd may be used on body of garment in separate scattered motifs, as shown in **Fig. 149**, following same procedure but without the cutting. This type of work is very effective in household linens, particularly table cloths, napkins, etc., using linen appliquéd to organdy.

SATIN APPLIQUÉD TO CHIFFON WITH WALLS OF TROY EMBROIDERY

Use **All-purpose Throat Plate**,

All-purpose Presser Foot 105069 (see page 22) for Walls of Troy.

Overlay chiffon with a strip of satin and underlay with crinoline or organdy, cutting both 2" wider than maximum depth of border design. Baste into position across top and bottom of bands.

Stamp or trace outline of design on right side of satin. Center design with Walls of Troy stitch (see **Line 7, pages 34 and 35**), setting Bight and Intervals in proportion to outline. For design in **Fig. 148**, machine was set for 2 Bight. Central Needle Position was alternated with Left Needle Position every 5 stitches.

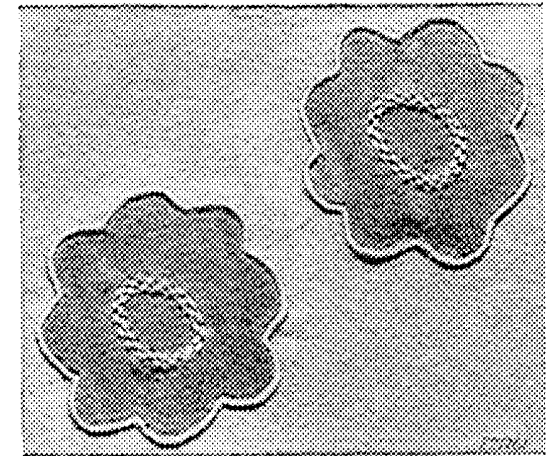
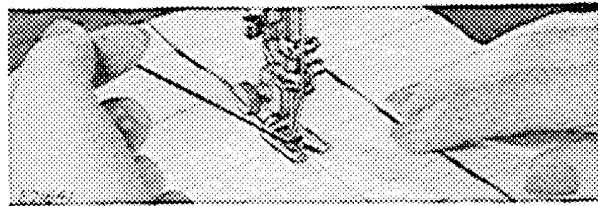

Fig. 149. Satin Appliquéd to Chiffon in Motif Design

CARRIER STITCHES FOR RIBBON THREADED SURFACE TRIM

Use **All-purpose Throat Plate**,
Satin Stitch Foot 189649 (see page 22),
 Central Needle Position,
 2 Bight, almost 0 Stitch setting.

Mark lines to be followed on face of garment, spacing them about $1\frac{1}{2}$ " apart lengthwise and about $\frac{3}{4}$ " apart crosswise.



*Fig. 151. Position of Yarn
While Free Stitching*

left, continue to stitch along lengthwise line free of yarn, up to second horizontal line. Picking up yarn again, overlay it up to third line when it is held aside again in order to free stitch up to fourth line. Continue to alternate in this way, overlaying and then free stitching all along lengthwise lines and up to each horizontal line. Using free loops of yarn as carriers, thread velvet or satin ribbon through them, as shown in **Fig 152**, using a different harmonizing color for each row. This treatment is particularly effective for a swing skirt, laying rows of ribbon from waist to hem. It is also effective when used for a bolero, scarf or stole.

Placing yarn under Satin Stitch Foot, bring yarn up between toes and into wide throat of Foot. Holding yarn high, overlay it into position along first lengthwise line and up to first horizontal line. Then, swinging yarn to

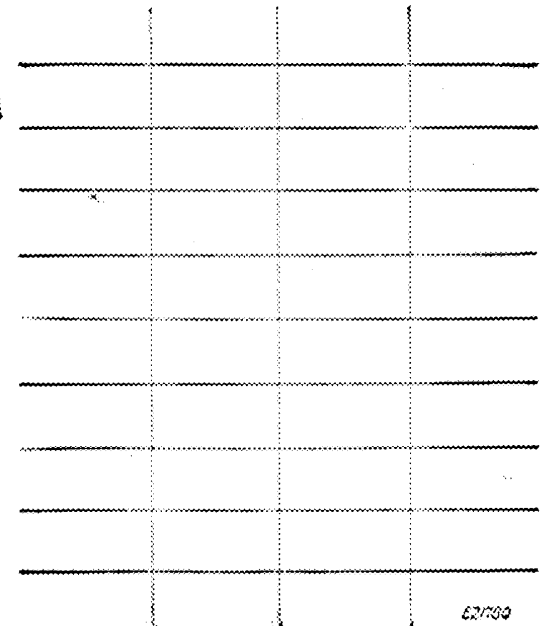

*Fig. 150. Markings for
Carrier Stitch*

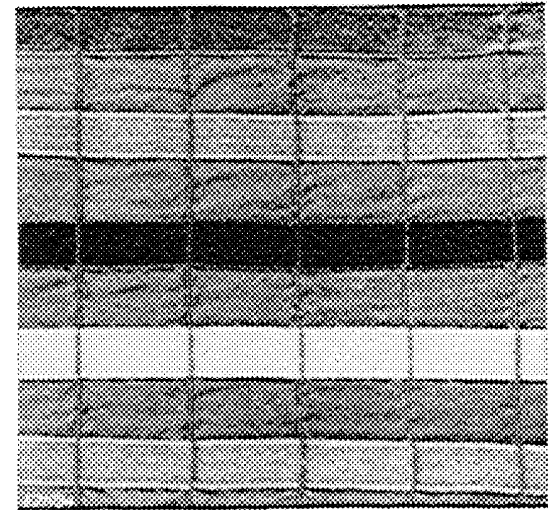

*Fig. 152. Ribbon Threaded
Carrier Stitches*

DIMENSIONAL APPLIQUÉ

Dimensional Appliqué is the term applied to embroidered motifs having sections free from body of garment but attached to it at a central or basic point forming part of design. This provides a very interesting third dimensional effect. In the flower illustrated in **Fig. 153**, the nine petals of the daisy and the two leaves are each embroidered separately before being cut out for appliqué.



Fig. 153. Dimensional Appliqué

Use **All-purpose Throat Plate, Satin Stitch Presser Foot 189649, Central Needle Position,**

very light upper tension, and a tight lower tension with Stitch setting at about 0. The Pressure is raised to point of permitting feeding without resistance around outlines of design.

For the petals of the daisy, trace or stamp each petal separately on sheer white organdy. Then with Bight set at 1, cover outline with Satin Stitch. For the leaves, trace design for each, separately, on sheer green organdy. Cover outline of each leaf with Satin Stitch using 2 Bight. Outline can be very easily seen through net which is added to provide a life-like texture to the leaves. Trace or stamp center and stem of daisy on white linen. Using 2 Bight, cover stem with Satin Stitches in green. Cut out each petal and leaf, close to stitches, and tack one end of each into position around center of daisy and on stem, overlaying petals as desired. Attach leaves with Satin Stitch **along lines of center vein only**, using 2 Bight. Attach petals with Satin Stitch used to form center of daisy, varying Bight from 1, gradually to 5, and gradually back again to 1. Petals and leaves may now be raised and curled by passing closed blades of small embroidery scissors lightly over ends.

MONOGRAMS

Monograms may be developed with unlimited variety by using or combining stitches described on pages 34 and 35. The monogram in Fig. 154 combines the Key Stitch (using **Satin Stitch Presser Foot 189649** and following **Line 12, pages 34 and 35**); covered Cord Stitch (using **Appliqué Foot 189650** as described on page 71); and Zigzag Stitch (using **All-purpose Presser Foot**).

Mark or stamp initials and then make the Key Stitch as on pages 34 and 35, except to take 10 stitches at 2 Bight and 16 stitches at 5 Bight. Then make Zigzag Stitch changing Needle Position to Central, Bight to 2, and Stitch setting to #1½ and using **All-purpose Presser Foot**. Finally add Covered Cord Stitch using **Appliqué Foot 189650**, and setting machine for Central Needle Position, 1 Bight and almost 0 Stitch setting. Insert Pearl Cotton #8 into eye of Appliqué Foot to raise corded effect. For all three stitches, use a light upper and tight lower tension.

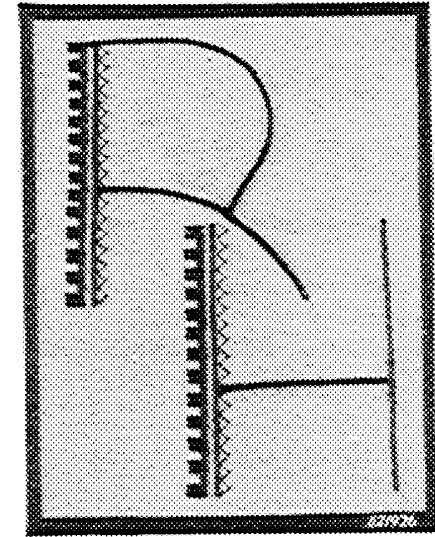

Fig. 154. Monogram

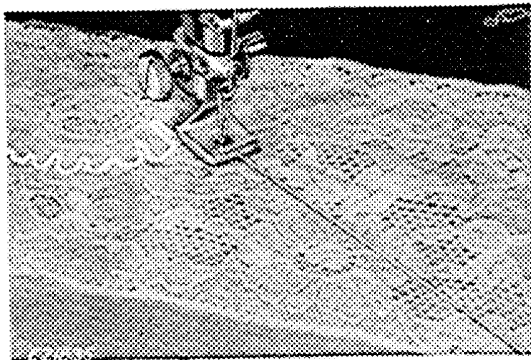

Fig. 155. Outlining Lace Motif with Embroidery Foot 189651

VIENNA WORK OR EMBROIDERED LACE

Vienna Work or Embroidered Lace is characteristic of high-priced lingerie. Yet it may be very quickly and easily accomplished with **Embroidery Foot 189651**, using fine rayon or silk crochet thread as the filler thread to be covered.

Use **All-purpose Throat Plate**,
Embroidery Foot 189651,
Central Needle Position.

1 Bight.

#1½ Stitch setting, light tensions and very light pressure.

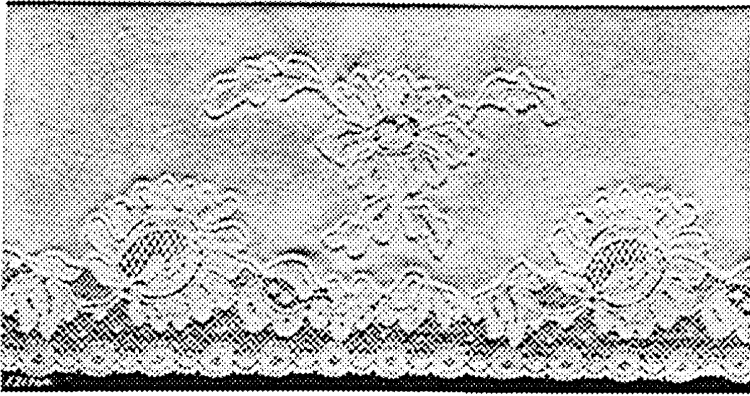

Fig. 156. Lace Motif Embroidered Into Satin

SCRIPT STITCH

Script Stitch is most effective for marking baby blankets, household linens, lingerie or accessories.

Lower the feed as instructed on Page 90.

Use **All-purpose Throat Plate,**
No Presser Foot,
 Central Needle Position,
 3 Bight,
 0 Stitch setting.

After tracing or marking lettering on right side of fabric, place in embroidery hoops large enough to encompass word or initials to be worked, with right side inside hoops. Place work under needle, lower the presser bar, position the needle and follow the outline traced. This work is very rapid and spontaneous and is often most effective when lettering is done freely, without stamping or tracing, but using the needle as one would a pen, to personalize the script with characteristic handwriting.

Use lace edging, at least 6" wide, with a definite floral design, and baste into position, where desired, on right side of fabric. First follow upper lines of motif nearest edge, covering filler cord with tiny stitches along lines of motif, and continuing in an unbroken, continuous line. Then choose a section of the motif nearest edge and fully outline this separate motif, repeating at evenly spaced intervals for length of the lace. Finally, remove bastings, cut away surplus lace close to stitches of corded outlines and, from wrong side of garment cut away surplus satin along edge, close to lines of cording.

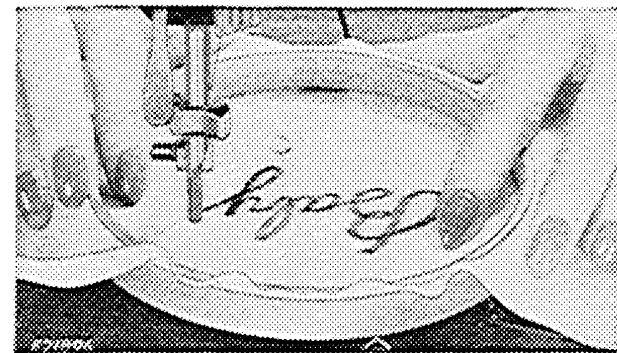

Fig. 157. Script Stitch in Hoops

DARNING STITCH

Darning Stitch is used for repairing socks, stockings, children's balbriggans, leggings and knit wear of all kinds as well as household linens. The SINGER® Stocking Darner will assist you in keeping the area to be darned taut and separate from rest of garment. Although not supplied with your machine, this Darner is available at your nearest SINGER SEWING CENTER. Run your hand in stocking or sleeve to place to be darned, and grasp frame of Darner, turning stocking or sleeve inside out over your hand, rolling excess length softly under anchoring hooks. This will bring right side of stocking or garment inside Darner with hole to be darned in direct center. Attach spring by fitting it into groove of Darner, over the stocking, and pulling it into place. Turn hinged arms over rolled stocking and ease soft roll under needle.



Fig. 158. Child's Balbriggan Shirt Darned with Stripes Matching in the Darn

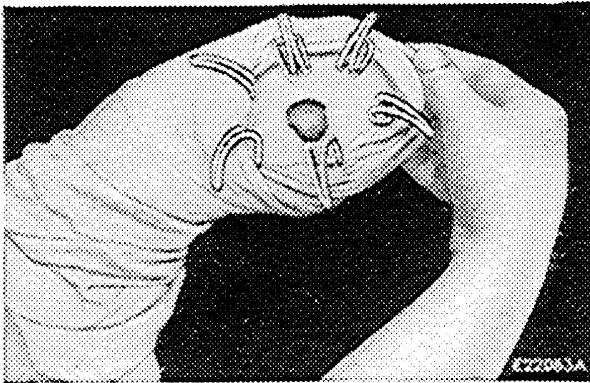

Fig. 159. Locating Darner on Stocking

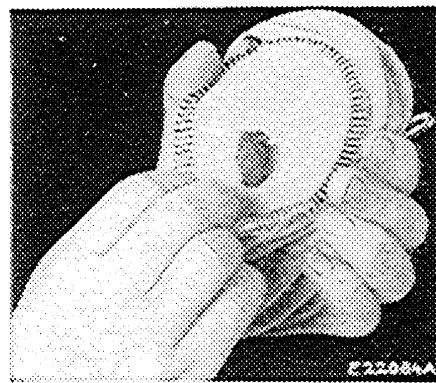

Fig. 160. Attaching Darner Spring

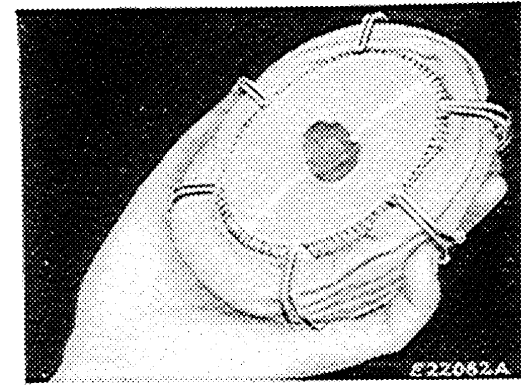

Fig. 161. Stocking Length Softly Rolled Under Hinged Arms

TO PREPARE MACHINE FOR DARNING

Lower the feed as instructed below.

Use **Straight Stitching Throat Plate 105055** (see **Page 20**), remove Presser Foot and use Needle only **without foot**, Central Needle Position, 0 Bight, 0 Stitch setting, light upper and lower tensions, #11 Needle and fine Mercerized Thread.

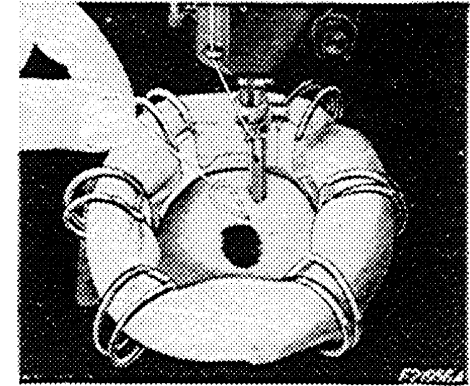

Fig. 162. Preparing to Darn

TO LOWER THE FEED

Turn machine back on its hinges. Loosen feed throw-out thumb

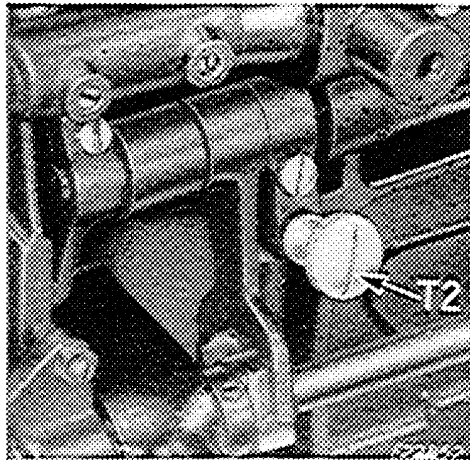
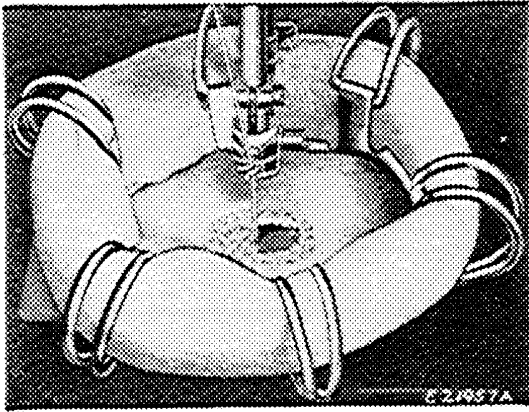

Fig. 162A. Adjustment for Lowering the Feed

screw **T2**, **Fig. 162A**, using a screwdriver if necessary, and turn it over to the left (counter clockwise) as far as it will go. The feed is thus rendered inoperative and will not interfere with the movement of the work. Bring machine forward into place. Move stitch regulator **G2**, **Fig. 27**, to its neutral position at center of slot and follow instructions for darning.

When regular sewing is resumed, tighten feed throw-out thumb screw **T2**, turning it over to the right (clockwise) as far as it will go and replace presser foot.

TO DARN, position needle about $\frac{1}{4}$ " outside hole. lower the presser bar and run re-enforcement stitches $\frac{1}{4}$ " from edge completely around hole, moving hoops with both hands. Then, with a steady, continuous



*Fig. 163. Partly
Finished Darn*

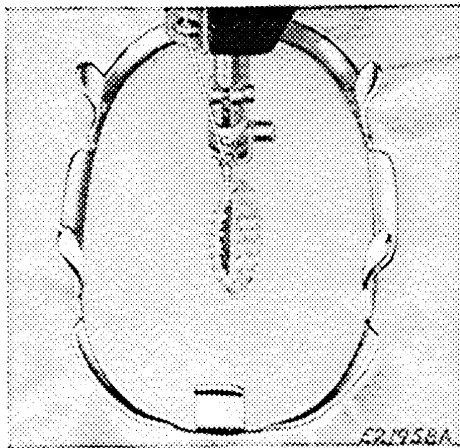

*Fig. 165. Darning
Table Linen*

movement, work backward and forward across hole, keeping the lines of stitching closely spaced and even, blending into the weave of stocking or garment. Slow movement of hoops will produce a short stitch, while quick movement will produce a longer stitch. In either case, the movement must be steady and rhythmic.

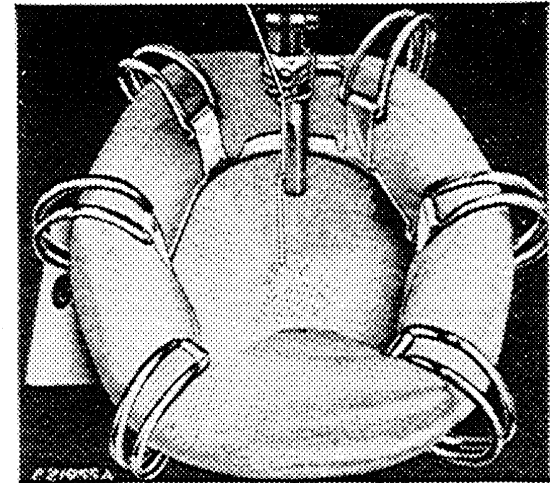

Fig. 164. Completed Darn

For socks and all knit or tricot weaves, the longer stitch is best, because it is softer when the garment is worn. For cottons and household linens, the short stitch is best, because it not only approximates the weave, but it also is strong enough to withstand many launderings.

Where the garment to be darned is striped or printed in several colors, the stripe or print should be matched in the darn, as shown in the illustration of the child's balbriggan shirt (see **Fig. 158, page 89**). In addition to the SINGER Stocking Darner, a SINGER* Darner for Linens and Flat Work is also available at low cost in your nearest SINGER SEWING CENTER.

FASHION STITCHES

The Darning Stitch is the simplest of Fashion Stitches, capable of many variations, according to rate of motion in moving hoops and direction in which stitches are laid.

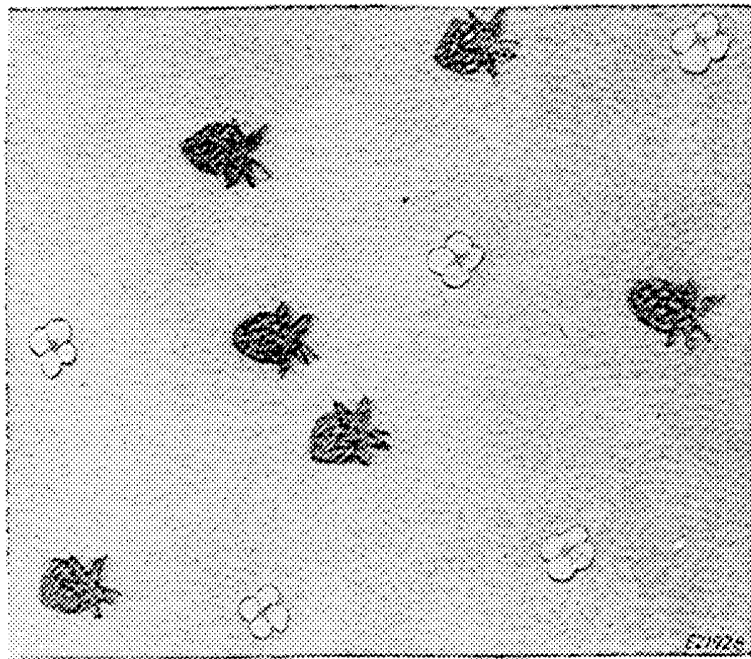

Fig. 166. Fruit and Flower in Darning Stitch and Spark or Shadow Stitch

Use **Straight Stitching Throat Plate 105055** and lower the feed, as instructed on **Page 90**.

Remove Presser Foot and use needle only **without foot**, Central Needle Position, 0 Bight, 0 Stitch setting, light upper and lower tensions, #11 needle and fine silk threads in appropriate colors.

Darning Stitch was used on both the strawberries and stems in **Fig. 166**. For strawberries, hoops are moved back and forth in a short, quick, rhythmic motion, laying stitches evenly, but not too close, and in a succession of rows, each about $\frac{1}{8}$ " deep, leaving a tiny spot free now and then, to represent seed spots of strawberry. For stems, darning stitches are laid very close and follow design as stamped on fabric.

Tiny blossoms are worked in Spark Stitch on **wrong** side of fabric. Loosening lower tension further, and tightening upper tension a degree or two, Spark Stitch is obtained by moving hoops in slow rhythm around each petal, beginning with top petal and working counterclockwise to finish the four petals. Since fabric is sheer, the result is a Shadow Stitch from the right side.

NOTE: With the familiarity of constant use, you will soon find it possible to obtain most of the stitching effects outlined in this book, using only the All-Purpose Throat Plate and All-Purpose Presser Foot, but for your convenience, and to expedite your work, the Extra Attachments are placed at your disposal.

INDEX

	PAGE		PAGE
Accented quilting.....	46	Cartridge pleats.....	66 & 67
All-purpose stitch equipment.....	22 & 23	Central needle position.....	24
Appliquéd cord on wide hem for sheers.....	56	Changing throat plate.....	30
Appliquéd hem.....	56	Channel seams.....	38
Appliqué work.....	56, 84 & 86	Chiffon with satin appliqué.....	84
Arrowheads on slot seam.....	38	Commencing to sew.....	31
		Contour darts.....	42
Belt with cartridge pleats.....	66	Contour shirrings.....	43 & 44
Bias bound edges.....	60 & 61	Corded braiding.....	70
Bight control.....	25	Corded edges.....	63, 64 & 65
Bight indicator scale.....	25	Cording.....	63, 64 & 65
Bight limit screws.....	25	Cording scallops.....	83
Binding curved edge.....	61	Cording seam.....	39
Blind stitched hem.....	53 & 54	Correct position at machine.....	18
Blind stitched zipper insertion.....	51 & 52	Crossed top stitching on channel seam.....	38
Bobbin, removing.....	14	Curved edge, binding.....	61
Bobbin, winding.....	14 & 15	Curved edges, hemming.....	59
Bobbin case, removing.....	14		
Bobbin case, replacing.....	16	Darning.....	89, 90 & 91
Bobbin case, threading.....	16	Decorative abutted seams.....	41
Bobbin thread tension, regulating.....	28	Designer's tucks.....	43
Braiding.....	68	Dimensional appliqué.....	86
Buttonholes, gimp.....	50	Direction of feed, regulating.....	26
Buttonholes, making.....	48, 49 & 50	Drawing up hobbin thread.....	17
Buttonholes, raised.....	50	Drawn thread work.....	81 & 82
Buttons, sewing on.....	46		
		Edge with scallop.....	83
Carrier stitches.....	85	Edges, fringed.....	81

INDEX (Continued)

	PAGE		PAGE
Elastic shirrings.....	44	Hem finished with seam tape, blind stitched.....	54
Electric motor.....	5	Hem for sheers.....	56
Electrical connections.....	5	Hem, narrow.....	58
Electrical information.....	5 & 6	Hem, shell stitched.....	57
Embroidered lace or Vienna work.....	87 & 88	Hem with folded edge, blind stitched.....	53
Examples of stitches.....	34	Hem with lace edging.....	58 & 59
Eyes and hooks and snaps, sewing on.....	47	Hemming curved edges.....	59
Fashion stitches.....	92	Hems, blind stitched.....	53 & 54
Feed, to lower.....	90	Hemstitching.....	81 & 82
Flat braiding.....	68	Hooks and eyes, sewing on.....	47
Foot controller.....	5	Inserting covered cord between garment and facing.....	64
Fringed edges.....	81	Inserting new bulb in light.....	6
French folds.....	62	Inserting zipper.....	51 & 52
French hemmed lace edging.....	59	Invisible seam for all-over lace.....	40
French quilting.....	44	Invisible seam for all-over lace embroidery..	40
Gathering with ruffler.....	74	Invisible seam for horsehair or net bandings	41
Geometric quilting.....	45	Italian quilting.....	45
Gimp buttonholes.....	50	Lace edging, French hemmed.....	59
Gophering or round pleating.....	80	Lace edging on narrow hem.....	58
Graduated tucks.....	42	Left needle position.....	24
Group pleating.....	79	Length of stitch, regulating.....	26
Hairline seam in sheers.....	39	Light.....	6
Hairline seam in tricot.....	39	Lubricating motor.....	9
Heavy duty, strain-proof and reversible seam.....	37	Machine, oiling.....	7, 8 & 9
Hem bordered with scallops.....	83		

INDEX (Continued)

	PAGE		PAGE
Machine setting for straight stitching.....	21	Operating the machine.....	18
Machine setting for zigzag stitching.....	23	Overcasting open seams.....	37
Making buttonholes.....	48, 49 & 50	Petal collar with wired edge.....	72
Mending a tear or rent.....	36	Piped binding.....	61
Mending a trouser pocket, glove seam or wallet seam.....	36	Piping a ruffle.....	77
Method of making various types of stitches	34 & 35	Pleating	73, 78, 79 & 80
Monograms	87	Preparing to sew.....	17
Motor, electric.....	5	Pressure on presser foot, regulating.....	27
Motor lubrication.....	9	Puffing	73 & 80
Multi-slotted binder	60, 61 & 62	Quilting	44, 45 & 46
Names of principal parts of Machine		Raised braiding.....	68
206K43	33	Raised buttonholes.....	50
Narrow hem.....	58	Re-enforcing heavy duty garments, girdles, garters, etc.....	36
Needle chart.....	10	Regulating direction of feed.....	26
Needle position control.....	24	Regulating length of stitch.....	26
Needle thread tension, regulating.....	28	Regulating needle thread tension.....	28
Needle thread tension, removing and replacing	29	Regulating pressure on presser foot.....	27
Needle, threading of.....	12 & 13	Removing bobbin.....	14
Needles and thread.....	10 & 11	Removing bobbin case.....	14
Net bound seams.....	62	Removing bulb from light.....	6
Oiling bobbin case holder.....	8	Removing needle thread tension.....	29 & 30
Oiling the machine.....	7, 8 & 9	Removing work from machine.....	18
Oiling the ruffler.....	79	Renewing elastic waistbands in cuffs on lingerie, knit wear or tricot.....	37

INDEX (Continued)

	PAGE		PAGE
Replacing bobbin case.....	16	Speed controller.....	5
Replacing needle thread tension.....	29 & 30	Stitch length, regulating.....	26
Ric-rac braiding.....	69	Straight stitch equipment.....	20 & 21
Rip-proof seam for lingerie.....	38	Suggestions for sewing.....	32
Round pleating or gophering.....	80		
Ruffler.....	73	Tensions, thread.....	27
Ruffler parts.....	73	Thread cording.....	71
Ruffling.....	73 to 80	Thread tensions.....	27
		Threading bobbin case.....	16
Satin appliquéd to chiffon.....	84	Threading needle.....	12 & 13
Satin stitched scallops.....	82	Threading ribbons through carrier stitching.....	85
Scallop bordered hem.....	83	Throat plate, changing.....	30
Scalloped edge.....	83	Torso or shaped darts.....	41
Scallops.....	82 & 83	Tricot wear with shadow hem.....	55
Script stitch.....	88	Triple corded edges.....	65
Setting needle in needle clamp.....	11	Tucks.....	42 & 43
Sewing on buttons.....	46		
Sewing on snaps, hooks and eyes.....	47	Upper Threading.....	12 & 13
Sewing suggestions.....	32		
Shadow hem.....	55	Velvets bound with net.....	62
Shadow stitch.....	92	Vienna work or embroidered lace.....	87 & 88
Sheer metallics bound with net.....	62		
Shell stitched hem.....	57	Wide hem.....	56
Shutter tucks.....	42	Wide hemstitching.....	81 & 82
Slot seam finished with arrowheads.....	38	Winding bobbin.....	14 & 15
Snaps, hooks and eyes, sewing on.....	47	Wired edges.....	72
Soutache braiding.....	68		
Spark stitch.....	92	Zipper insertion.....	51 & 52

TO ALL WHOM IT MAY CONCERN:

The improper placing or renewal of the Trade Mark "**SINGER**" or any other of the Trade Marks of The Singer Manufacturing Company (all of which are duly Registered Trade Marks) on any machine that has been repaired, rebuilt, reconditioned, or altered in any way whatsoever outside a **SINGER** factory or an authorized **SINGER** agency is forbidden.

For your protection

SINGER sells its machines only through SINGER SEWING CENTERS, identified by the Red "S" on the window, and never through department stores or other outlets.

When your machine needs servicing, call your SINGER SEWING CENTER and be sure of warranted SINGER parts and service.

See address in classified telephone directory listed only under

SINGER SEWING MACHINE COMPANY

