



Instructions for using

SINGER

Sewing Machine

MODEL 201

THE SINGER MANUFACTURING COMPANY

Instructions for Using

SINGER*

Form K6053
(458)

All Rights Reserved

Printed in Great Britain

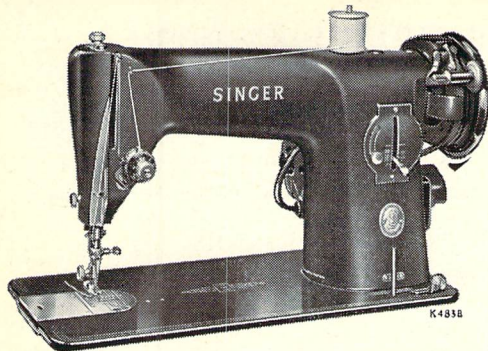

SEWING MACHINE 201K

The **SINGER 201K** is another in a long line of products resulting from the skill and ability of **SINGER** craftsmen.

*A Trade Mark of **THE SINGER MANUFACTURING CO.**

WHEN YOU OWN A **SINGER** 201K MACHINE

You own a machine with a tradition of superior craftsmanship—a tradition you will recognise in the smooth running of this sewing machine which, operating either forward or backward, forms a perfect lock stitch.



TO GET THE MOST ENJOYMENT FROM YOUR **SINGER**

You are entitled to sewing lessons when you become the owner of a new **SINGER**. A skilled, **SINGER**-trained teacher personally guides you and assists you in learning the fundamentals of home sewing. Other courses embracing all phases of home sewing are available at low cost.

SINGER

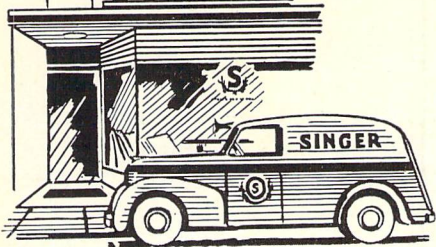

when needed! Look for the familiar red "S" Trade Mark on your SINGER SEWING CENTRE and the ever ready SINGER Service Car.

EVERYTHING FOR THE WOMAN WHO SEWS

The answer to your sewing needs is at your SINGER SEWING CENTRE. There you will find a wide choice of sewing necessities and notions, sewing instructions and guidance and services for covering buttons, hemstitching, making belts and buckles, to mention a few. Look in your telephone directory under SINGER SEWING MACHINE COMPANY for the SINGER SEWING CENTRE nearest you.

SINGER SERVICE

Wherever you go you will find expert, dependable SINGER* Service nearby. SINGER is interested in helping you keep your SINGER Sewing Machine in top condition. That is why you should always call your SINGER SEWING CENTRE if your machine ever requires adjustment or repair. When you call your SINGER SEWING CENTRE you can be sure of obtaining the service of a trained SINGER repair man and can be assured of warranted SINGER* parts

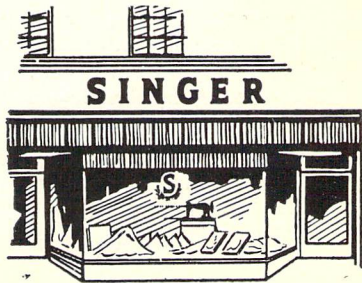

ELECTRICAL INFORMATION

The SINGER* Electric Motor

is located at the back of the machine, and can be supplied for operation on alternating or direct current. Orders must state the catalogue number of the motor, or the voltage, and in the case of alternating current, the number of cycles.

Before Inserting Electric Plug—

be sure that voltage and number of cycles stamped on motor nameplate are within range marked on electric meter installed by electric power company.

Electrical Connections for Machine

Push three-pin safety plug into three-pin terminal block at right of machine and connect plug at other end of cord to electric supply point.

Speed Controller

The speed of machine is regulated by amount of pressure on foot controller or knee controller.

CAUTION

When you have finished your sewing always disconnect the plug from the electric supply point.

LIGHT

To Turn Light "on" or "off."

To turn on light, reach over machine arm and turn switch **B**, **Fig. 1** clockwise. To extinguish light turn switch anti-clockwise.

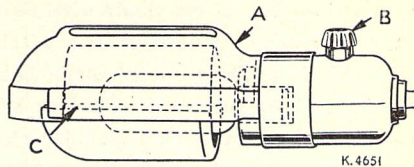

Fig. 1. SINGER Light.

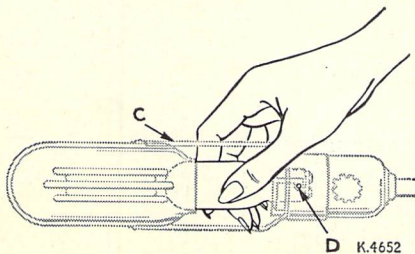

Fig. 2. Removing and replacing bulb.

To Remove Bulb

Grasp light socket so that thumb extends over switch **B**. Press shade with thumb at **A** to release shade from two catches, and slide it halfway out of shade holder **C**. Press bulb into socket and at same time turn bulb over from machine as far as it will go to unlock pin **D** (see **Figs. 3** and **4**). Withdraw the bulb.

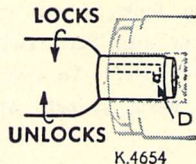

Fig. 3. Locking or unlocking bulb pin.

To Insert New Bulb

Press bulb into socket and turn it over toward machine until pin **D** enters notch in socket (see **Fig. 3**). Return shade to its normal position as shown in **Fig. 1**.

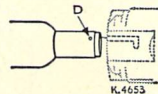
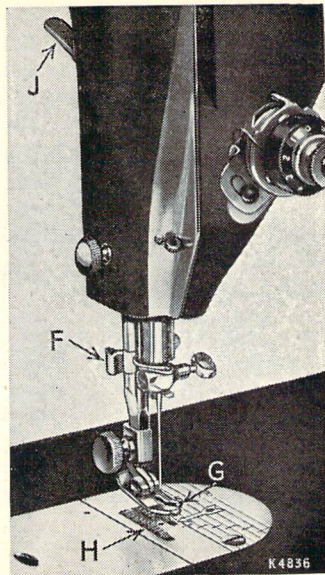

Fig. 4. Inserting bulb in socket.

IF MACHINE IS ELECTRICALLY OPERATED

Raise presser foot **G** by means of presser bar lifter **J** to prevent injury to the foot **G** and feed **H**.

Place a piece of material under presser foot and let the foot down upon it. Turn on electric current and, if the combination knee and foot controller is installed as a knee controller, press knee lever to the right. If controller is placed on the floor to be used as a foot controller, press down on pedal of controller. The speed of the machine is controlled entirely by the amount of pressure applied to the controller. Operate machine in this way, without being threaded, until you have become accustomed to guiding the material and operating the controller.



IF MACHINE IS HAND OPERATED

When the machine is uncovered, the hand attachment will be found to be out of working position as shown in **Fig. 6**. Pull the small spring stud **2**, and turn the handle back until the lever **1**, enters the socket **3**. Press back the hinged finger **4**, **Fig. 7** between the spokes of the wheel. The machine is now ready for working, as shown in **Fig. 7**.

NOTE. Before replacing the cover or the machine in its case, the lever should be disengaged and the handle placed in the position shown in **Fig. 6**.

TO OPERATE THE HAND MACHINE

Place a piece of material under the presser foot **Q**, **Fig. 5**, and lower the latter by means of the lifter **R**.

Now turn the handle **over from you** to work the machine, without being threaded, until you are accustomed to guiding the material with the left hand.

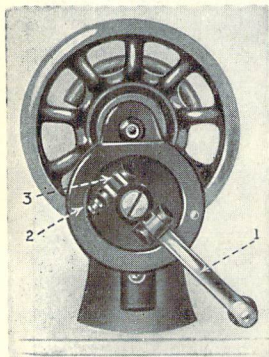

Fig. 6.

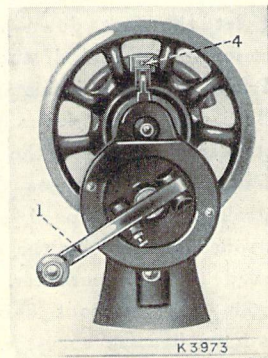

Fig. 7.

IF MACHINE IS TREADLE OPERATED

Loosen the hand wheel by turning stop motion screw 17, Fig. 12, over toward you, place both feet upon the treadle and turn the hand wheel over toward you, at the same time allowing the feet to move freely and lightly with the motion of the treadle. Continue to do this until a regular and easy movement is acquired and you are able to work the treadle so that you can re-start the machine with the wheel turning toward you.

When familiar with the working movement, tighten the hand wheel by turning the stop motion screw over from you, and place a piece of material under the presser foot Q, Fig. 5. Lower the latter by means of the lifter and again work the machine, without being threaded, until you are accustomed to guiding the material.

The belt should be only just tight enough not to slip. If too loose, shorten and rejoin.

BELT SHIFTER

This device simplifies throwing off and replacing the belt. To throw off the belt, move the belt shifter to the left (see Fig. 8), working the treadle at the same time. To replace the belt, work the treadle slowly with the hand wheel turning toward you, when a revolution or two of the wheel will bring the belt back into its place.

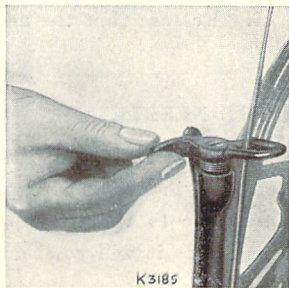

Fig. 8.

NEEDLES AND THREAD

This machine uses a 15x1 Needle—available in sizes 9, 11, 14, 16, 18, 19 and 21.

For perfect stitching, the thread should be selected according to the fabric to be stitched and the needle must be of the correct size for the thread which must pass freely through eye of needle. Select the correct needle according to the chart on page 11. Be sure that the needle is not blunt or bent.

TO SET THE NEEDLE

Raise needle bar to its highest position and loosen thumb screw A in needle clamp. Insert needle with its flat side to the left up into the needle clamp B as far as it will go, then tighten thumb screw A.

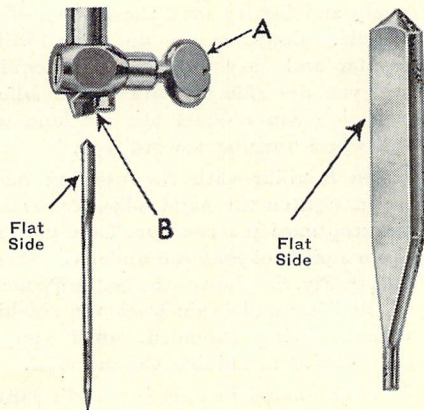

Fig. 9. Setting the Needle.

**CHART SHOWING THE RELATIONSHIP OF TYPES OF FABRICS, THREAD
AND NEEDLE SIZES AND MACHINE STITCHES TO THE INCH**

Types of Fabrics	Thread Sizes	Needle Sizes	Machine Stitches per inch	
			Inside Seams	Top Stitching
Very thin Silk, Muslin, Cambric, Light-weight Delicate Fabrics, etc.	100 to 150 Cotton, 50 Silk, 80 Mercerised Darning Cotton	9	20	25 to 30
Fine Calicoes, Linens, Shirtings, Fine Silk Goods, etc.	80 to 100 Cotton, 50 Silk, 50 Mercerised Darning Cotton	11	16	20
Plastic Materials	50 to 80 Mercerised Cotton	11	10	12
Shirtings, Sheetings, Bleached Calicoes, Silk and General Domestic Goods, Light Woollen Goods and all classes of general work	60 to 80 Cotton, 50 Silk, 50 Sylko	14	12	18
All kinds of heavy Calicoes, Drill, Woollen Goods, etc.	40 to 60 Cotton	16	10	12
Tickings, Heavy Wollens, Trousers, Boys' Clothing, Corsets, Cloaks, Mantles, Heavy Coats, and Heavy Clothing generally	24 to 40 Cotton, 60 to 80 Linen	18 or 19	8	10
Bags, Coarse Cloths, Canvas, Duck, Heavy Goods of any texture	40 to 60 Linen, or very coarse cotton	19 or 21	6	8

When ordering needles, always specify "Class and Variety 15x1" and state the size and quantity required. You will obtain the best stitching results from your Sewing Machine if it is fitted with a SINGER* Needle.

UPPER THREADING

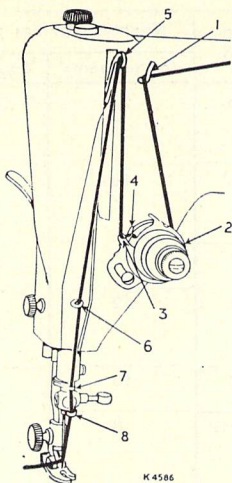

Fig. 10.

See Fig. 10.

Raise take-up lever **5** to its highest point.

Place spool of thread on spool pin.

Lead thread into thread guide **1**.

Down and from right to left between tension discs **2**.

Into the loop of the take-up spring **3** and to the right until it enters the fork **4**.

Up and from right to left through hole in take-up lever **5**.

Down through guide **6** on face plate.

Down through guide **7** into guide **8**.

From **right to left** through the eye of the needle.

Draw about two inches of thread through the eye of the needle with which to begin sewing.

TO REMOVE BOBBIN

Raise the needle to its highest point.

Draw to the left the slide (C) in the bed of the machine and remove the bobbin with the thumb and forefinger of the left hand, as shown in Fig. 11.



Fig. 11. Removing the Bobbin.

TO WIND BOBBIN. *See Fig. 12.*

1. Place bobbin on spindle with pin of spindle entering hole in right side of bobbin.
2. Lock bobbin in place by pressing bobbin winder down until latch 15, Fig. 12 engages.
3. Place spool of thread on spool pin 12. Draw thread under and between tension discs 13. Lead thread up through hole in bobbin 14 from the inside.
4. Hold hand wheel 16 and loosen knurled screw 17 by turning it over toward you.
5. Hold end of thread and operate machine as for sewing. Continue to hold end of thread until it breaks off.

Allow tension discs to control flow of thread. Do not guide or hold thread when winding bobbin.

The bobbin winder will stop automatically when the bobbin is filled.

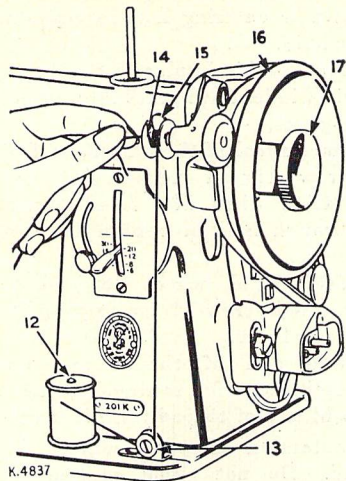

Fig. 12. Winding the Bobbin.

Remove bobbin from spindle and tighten knurled screw 17.

If pressure of bobbin winder pulley against hub of hand wheel is insufficient for winding the bobbin, press down bobbin winder until latch 15, Fig. 13 drops and holds it in position. Loosen adjusting screw 18, Fig. 13. With forefinger, push back upper end of slotted plate 19 as far as it will go, as shown in Fig. 13, and at the same time, press bobbin winder pulley against hub of hand wheel. Tighten adjusting screw 18. If thread does not wind evenly on bobbin, loosen screw which holds tension bracket 13, Fig. 12 in position. Move bracket to the left if bobbin winds high on right; move bracket to the right if bobbin winds high on left. When bracket is properly centred, thread will wind evenly across bobbin.

Bobbins can be wound while machine is sewing. Follow instructions on page 13 omitting item 4.

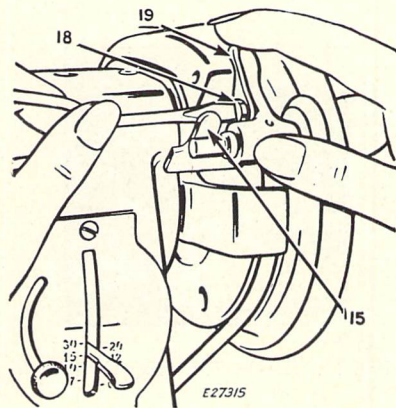

Fig. 13. Adjustment of Bobbin Winder.

TO REPLACE BOBBIN

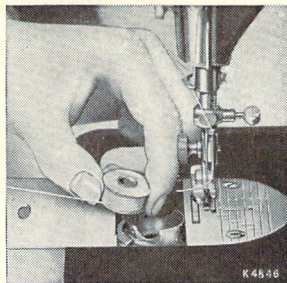
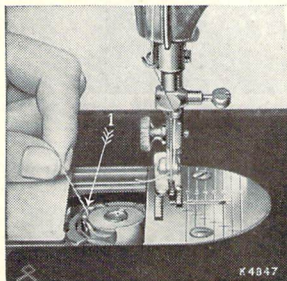

Fig. 14. Replacing the Bobbin.



15 Fig. 15. Threading the Bobbin Case.

Hold the bobbin between the thumb and forefinger of the left hand, the thread drawing from right to left, as shown in Fig. 14.

Place the bobbin into the bobbin case and draw the thread into the slot 1, Fig. 15 in the bobbin case, as shown. Draw the thread backward between

the bobbin case and the tension spring until it reaches the notch 2, Fig. 16, then pull the thread toward the right, as shown

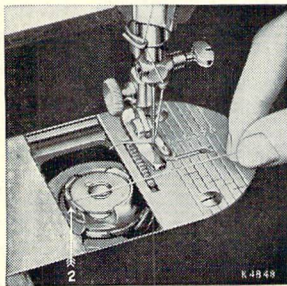

Fig. 16. Bobbin Case Threaded.

in Fig. 16. Close the slide, as shown in Fig. 17.

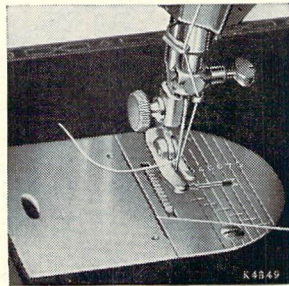

Fig. 17. Under Threading Completed.

TO PREPARE FOR SEWING

Have the thread take-up lever at its highest position, then, with the left

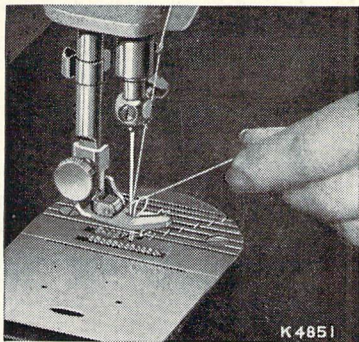

Fig. 18. Drawing Up the Under Thread.

hand, hold the end of the needle thread, leaving it slack from the hand to the needle. Turn the hand wheel over toward you until the needle moves down and up again to its highest position, thus catching the bobbin thread. Draw up the needle thread and the bobbin thread will come up with it through the hole in the throat plate as shown in **Fig. 18**.

Lay both threads back under the presser foot diagonally across the feed, to the right or left, depending upon which side of the needle the material is to be located so that when the presser foot is lowered, the threads will be firmly held between the feed and the presser foot.

TO START SEWING

See Fig. 19.

Be sure to have thread take-up lever **5**, **Fig. 10** in its highest position.

The throat plate has guide lines for seam width gauged from centre of needle hole, and cross lines for gauging square corners.

Place material beneath the presser foot **G**, turn the hand wheel to bring the point of the needle into the material, then lower the presser foot by means of presser bar lifter **J**, and start to sew.

Some materials, such as soft finished sheers, nylons, jerseys, tricots and other elastic and spongy textiles, require a slight amount of assistance in feeding during sewing operations.

However, too much pull will stretch the seam, create irregular stitching and bend the needle. Most materials require only guiding for best sewing results.

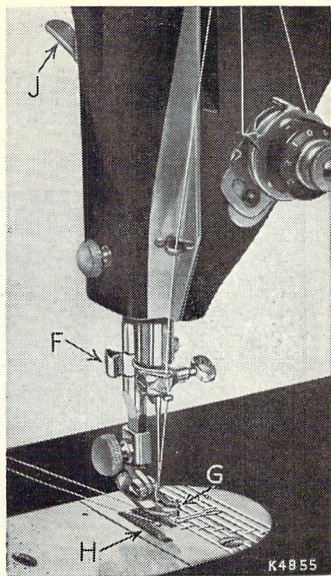

Fig. 19. To Start Sewing.

TO TURN A CORNER

Stop the machine when the needle eye, making its upward stroke, is still in the fabric. Raise the presser foot and turn the work as desired, using the needle as a pivot, then lower the presser foot.

BASTING

The longest stitch, No. 6 on the stitch indicator, is satisfactory for basting and is easily removed by clipping every sixth stitch and withdrawing the long continuous thread.

Machine basting is firmer and more even than that done by hand in addition to being much quicker.

TO SEW BIAS SEAMS

Use a short stitch and as light a tension as possible on the needle thread so that the thread is loose enough in the seam to allow the goods to stretch if necessary.

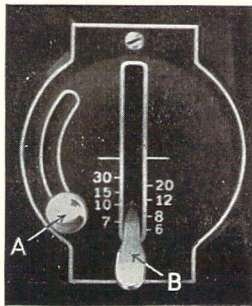

Fig. 20. To Regulate Stitch Length.

TO REMOVE THE WORK

Stop the machine with the thread take-up lever **5**, **Fig. 10** at its highest point. Raise the presser foot by means of presser bar lifter **J**, **Fig. 19**, draw the fabric back and to the left and sever the threads on thread cutter **F**, **Fig. 19**. Place ends of threads under presser foot. When the machine is not in use, raise the presser foot by means of presser bar lifter to prevent injury to the presser foot **G** and the feed **H**, **Fig. 19**.

CAUTION :

When the machine is not in use, raise the presser foot by means of presser bar lifter **J** to prevent injury to the presser foot and the feed **H**, **Fig. 19**.

TO REGULATE LENGTH OF STITCH AND DIRECTION OF FEED. *See Fig. 20.*

The machine can be adjusted to make from 6 to 30 stitches to the inch, as indicated by the numerals on the stitch indicator plate.

Loosen screw **A** and lower it to the bottom of the slot, then move lever **B** until its top edge is level with the figure denoting the number of stitches desired per inch. Raise screw **A** as far as possible, and tighten it. Thus set, the machine will make the indicated number of stitches in a forward direction. If it is desired to reverse the direction of the stitching, raise lever **B** as far as possible, and the machine will make the same number of stitches in a backward direction.

TO REGULATE PRESSURE ON MATERIAL

For ordinary sewing, the pressure of the presser foot on the material seldom requires changing. Heavy materials require more pressure than light weight materials. The pressure should be only heavy enough to prevent the material from rising with the needle and to enable

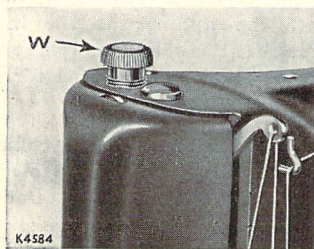

Fig. 21. Thumb Screw for Regulating Pressure on Presser Foot.

the feed to move the work along evenly. To increase the pressure, turn the thumb screw **W**, **Fig. 21** clockwise or downward. To lighten the pressure, turn the thumb screw upward.

THREAD TENSIONS

For perfect stitching, the tension on the needle and bobbin threads must be heavy enough to pull the threads to the centre of the thickness of the material and make a firm stitch, as shown in **Fig. 22**.

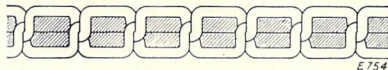

Fig. 22. Perfect Stitching.

If the needle thread lies straight along the top side of the material, the tension

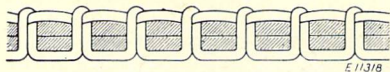

Fig. 23. *Imperfect Stitching.*

on the needle thread is too heavy or the tension on the bobbin thread is too light, as shown in **Fig. 23.**

If the bobbin thread lies straight along the underside of the material, the tension on the needle thread is too light or the tension on the bobbin thread is too heavy, as shown in **Fig. 24.**

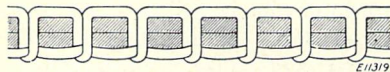

Fig. 24. *Imperfect Stitching.*

TO REGULATE NEEDLE THREAD TENSION

See Fig. 25.

The tension on the needle thread can be tested only when the presser foot is down.

The numerals “0” to “9” on dial **B**, indicate the different degrees of tension that can be obtained.

When the tension has been correctly set note the number at the indicator line **C**, so that this setting may be regained should the tension be altered for special work.

To increase tension, turn the thumb nut **A** gradually to the right (clockwise) until the required tension is obtained.

Each higher number denotes increased tension.

To decrease tension, turn the thumb nut **A** gradually to the left (counter-clockwise) until the required tension is obtained. Each lower number denotes less tension.

The tension indicator **C** is marked with the signs $+$ and $-$, which indicate the direction in which to turn the thumb nut **A** for more or less tension.

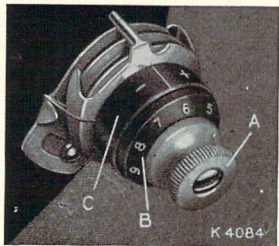

Fig. 25. To Regulate Needle Thread Tension.

TO REGULATE BOBBIN THREAD TENSION

The tension on the bobbin thread is regulated by screw **F**, **Fig. 36**, which is nearest the centre of the tension spring on the outside of the bobbin case. To increase the tension, turn screw **F** over to the right. To decrease the tension, turn this screw to the left.

When the tension on the bobbin thread has been once properly adjusted, it is seldom necessary to change it, as a correct stitch can usually be obtained by varying the tension on the needle thread.

TO DISASSEMBLE NEEDLE THREAD TENSION

See Fig. 26.

Turn thumb nut **B** to the left until the numeral **0** on numbered dial **D** stops opposite the centre line between the plus and minus signs, then press in the dial to disengage pin **C** in the thumb nut from the dial, and remove thumb nut and dial, stop washer **E**, tension spring **F**,

indicator **G** and tension disc assembly **H** which includes the thread take-up spring, thread guard plate and two discs.

Note : It is not necessary to remove stud **O** from the machine arm to disassemble the thread tension. It is shown removed in **Fig. 26** only for the purpose of illustration.

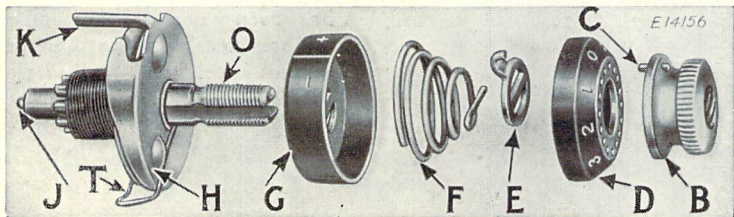

Fig. 26. Needle Thread Tension Disassembled.

TO REASSEMBLE NEEDLE THREAD TENSION

(See Figs. 27 and 28).

First make sure that tension releasing pin **J**, only the end of which is shown in Fig. 26, is in place in stud **O**. Place the two tension discs **L** with their flat thread-bearing sides together in position on thread guard **M**, then pass eyelet **N** of the thread take-up spring under the thread guard, having the coils of the spring above the tension discs as shown in Fig. 27. Guide the tension disc assembly on to the stud so that extension **K**, Fig. 26 of the thread guard enters the hole in the machine arm, and the tail (inside the coil) of the thread take-up spring enters one of the grooves in the stud. Next replace indicator **G** with the large open

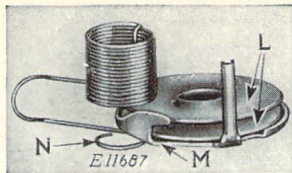

Fig. 27. Tension Disc Assembly.

side facing the end of the stud so that the plus and minus marks will be at the top (with the minus sign at the left) and hold the parts, thus assembled, against the shoulder of stud **O**. Then insert tension spring **F** in the indicator with the first (half) coil of the spring straddling the lower half of the stud. Guide stop washer **E** on to the stud so that the extension will be above the tension stud.

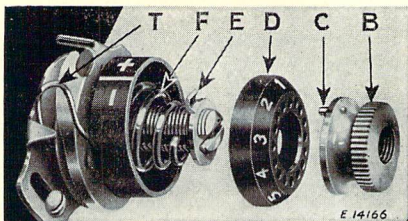

Fig. 28. Reassembling Needle Thread Tension.

If the spring and stop washer are in correct position, extension S will clear the first (half) coil of tension spring as shown in **Fig. 29**.

Next place the numbered dial on the stud so that numeral 2 is opposite the stop washer extension, then push the dial to compress the spring so that the thumb nut can be turned on to the stud, carefully guiding pin C in the thumb nut

into one of the holes of numbered dial D. Then proceed to adjust the tension as instructed below.

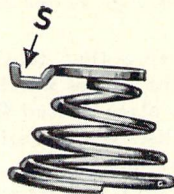

Fig. 29. Stop Washer and Tension Spring.

TO ADJUST NEEDLE THREAD TENSION

Lower the presser bar and turn thumb nut B to the left until numeral 0 on numbered dial D stops opposite centre line on indicator G. Thread the tension and pull the thread through the tension discs to test the amount of tension on the thread at the "0" position. At this point there should be a slight pull on the

thread to indicate that there is a minimum tension, which gradually increases with the turn of the thumb nut to the right, providing a full range of tensions from light to heavy within one revolution of the thumb nut. If the pull is too strong for a minimum tension, press in the numbered dial to disengage the pin in the thumb nut from the dial, and reset the pin in one of the holes to the left of the previous setting.

This resetting of the pin will produce less tension at zero. Repeat this process until the minimum desired tension is obtained. On the other hand, should there be no tension at zero, press in the dial and reset the pin in one of the holes to the **right** of the previous setting, repeating this process until a slight minimum tension is obtained.

TO ADJUST TENSION ON THREAD TAKE-UP SPRING

The tension on thread take-up spring **T, Fig. 28** should be just sufficient to take up the slack of the needle thread until the eye of the needle reaches the goods in its descent.

If the tension on the thread take-up spring requires adjustment, remove the tension disc assembly, disengage the end of the spring from the groove in the tension stud, revolve the spring and place its end in the groove which produces the correct tension.

**IF CORRECT STITCHING IS NOT
OBTAINED**

If bobbin thread tension has been disturbed, or a correct stitch cannot be obtained without a very heavy or very light needle thread tension, then the following procedure is recommended :

Using size 50 mercerised thread in needle and on bobbin, adjust needle thread tension as instructed on page 22.

Then turn tension thumb nut to "4" and, with two thicknesses of thin material in machine, adjust bobbin thread tension as instructed on page 23, until stitch is correctly locked in material.

A wide range of materials and threads can now be accommodated without further adjustment of bobbin thread tension.

**Free instruction for using the machine is gladly given at any
SINGER SEWING CENTRE**

DARNING (See Fig. 30).

Raise needle to its highest point, turn machine back on its hinges, unscrew knurled screw **A**, as far as it will go, and move crank **B** down so that the screw **A** will enter the upper hole **C**. The screw should then be securely tightened. The feed is now inactive and will not impede free movement of the work. Restore machine to its working position and raise the presser bar. Remove the presser foot and fit Spring Darning Foot No. 121094, but do not tighten the thumb screw. Stretch tightly the article to be repaired in an embroidery hoop and place below the needle by tilting the edge of the hoop. Then lower the presser bar by means of its lifter, and adjust the height of the darning foot to allow just sufficient space for the free movement of the work in hand. After adjustment, tighten the thumb screw securely. Now move the hoop backward and forward by the hands until the hole or damaged part is completely covered with stitching in one direction. Then turn the work and stitch across to complete the darn. After darning, reinsert and firmly tighten the screw **A** in the lower hole, and replace the presser foot for ordinary sewing.

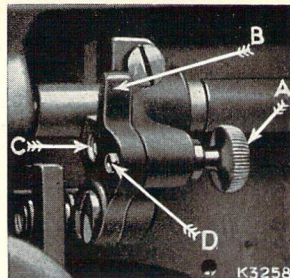

Fig. 30.

EMBROIDERY

For surface embroidery, remove the presser foot to give a clear view of the stitching. For lace embroidery, i.e. open work, remove the ordinary presser foot and fit Spring Foot No. 121094. For embroidery the feed should be lowered and the work handled as advised in the preceding paragraph.

SEWING SUGGESTIONS

Breaking of needles might be caused by

1. Improper size of needle for thread and material—See **page 11.**
2. Bent needle.
3. Pulling of material when stitching.
4. Needle striking improperly fastened presser foot or attachment.
5. Crossing thick seams with too small a needle.

Breaking of needle thread might be caused by :

1. A knot in thread.
2. Improper threading—See **page 12.**
3. Upper tension too tight—See **pages 22 and 23.**
4. Needle set incorrectly—See **page 10.**
5. Needle blunt or bent.
6. Thread too coarse for needle—See **page 11.**

7. Roughened hole in throat plate.

8. Improper arrangement of threads to start sewing—See **page 18.**

Breaking of bobbin thread might be caused by :

1. Improper threading of bobbin case—See **page 15.**
2. Bobbin thread tension too tight—See **page 23.**
3. Bobbin wound unevenly.

Skipping of stitches might be caused by :

1. Improper setting of needle—See **page 10.**
2. Needle blunt or bent.
3. Needle too small for thread—See **page 11.**
4. Needle rubbing presser foot.

PROTECTION AGAINST RUST DAMAGE

Lint and fluff, if not removed prior to storage will, during humid periods, absorb and hold moisture, and thus accelerate rust damage to highly polished thread handling and other exposed parts. The extent of rust damage would depend upon the length of time the machine remained in idle storage where there is no ventilation. Sudden drops in temperature will cause moisture to form on parts which, if not protected by a film of oil, would rust and damage while in storage.

Proper storage care suggests thorough brush-cleaning to remove all traces of lint and fluff, followed by swabbing of all the exposed parts in **Figs. 32 and 33** with a lint-free brush saturated with SINGER Oil.



*SINGER Lint Brush may be purchased at
your local SINGER SEWING CENTRE.*

TO OIL MACHINE and STAND

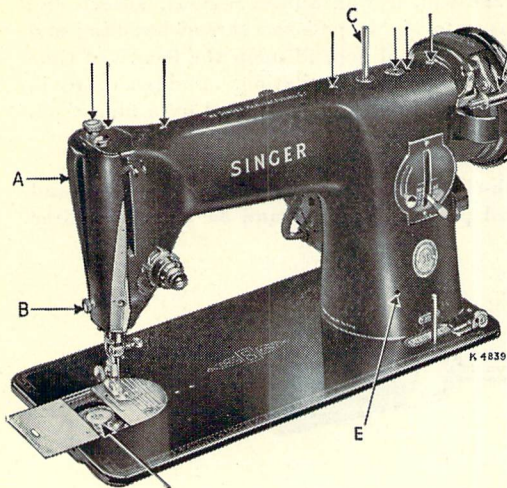

Fig. 31. Front View, Showing Oiling Points.

The Arm Spool Pin C is screwed for insertion in the left plugged hole and it is also provided with a screw driver slot. If the machine is used continuously, it should be oiled daily. If moderately used, an occasional oiling is sufficient. Apply one drop of oil to each of the places indicated in Figs. 31, 32, 33, 34 and 35 and carefully clean the machine to insure smooth and satisfactory performance. Oil holes are provided in the machine for bearings which cannot be directly reached.

Remove face plate A, Fig. 31, by taking out screw B and slipping plate over screw D, Fig. 32. After oiling replace face plate. Draw to the left the slide in the bed of the machine, as shown in Fig. 31, while the

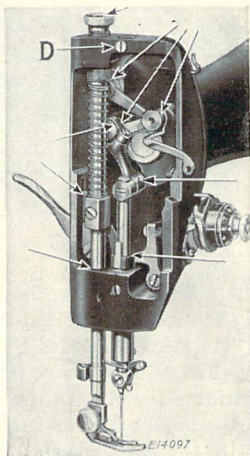

Fig. 32. Face Plate Removed, Showing Oiling Points.

thread take-up lever (5, Fig. 10) is at its highest position, and, after removing the lint and dust which may have accumulated (see instructions on page 31), apply one drop of oil to the sewing hook race in the bobbin case, as indicated by arrow "A" in Fig. 33, and a few drops to the oil hole "B" in Fig. 33. Then close the slide.

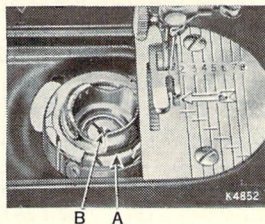

Fig. 33. Oiling the Sewing Hook.

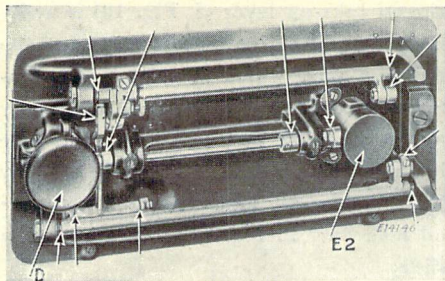

Fig. 34. Oiling Points in Bed of Machine.

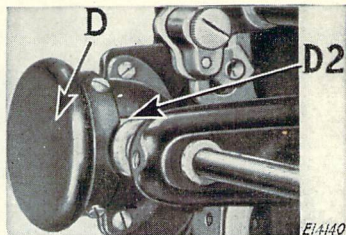

Fig. 35.

To oil the parts underneath the bed of the machine, turn the machine back on its hinges and apply oil to the oil holes and bearings indicated in **Fig. 34**. The gears concealed by the gear cover (**E2, Fig. 34**) are oiled through the oil hole (**E, Fig. 31**). The gears concealed by gear cover (**D, Fig. 34**) are oiled through the space just above this cover, as indicated by arrow (**D2, Fig. 35**). After oiling at **D2**, rotate the hand wheel toward you to distribute the oil on these gears. To oil the stand, apply a drop of oil to the centres upon which the band wheel and treadle work, and to both ends of the pitman rod connecting the treadle with the band wheel. After oiling, run the machine rapidly for a few minutes so that the oil may reach the bearings. **Neglect to oil the machine will shorten its life and cause you trouble and annoyance. Always use SINGER* oil. Inferior oil clogs the bearings, prevents efficient working, and causes rapid wear of the mechanism.**

TO CLEAN STITCH FORMING MECHANISM

After considerable use, the stitch forming mechanism may become clogged with lint and this may interfere with the perfect operation of the machine.

Occasionally remove the bobbin case according to the following instructions, and remove any lint, etc., which has accumulated.

TO REMOVE BOBBIN CASE

See Fig. 36.

The bobbin case may be easily removed without taking off the throat plate, although for the purpose of illustration the throat plate and feed dog are shown broken away.

Remove bobbin from the bobbin case. Turn hand wheel over toward you until the end of hook ring E is toward the

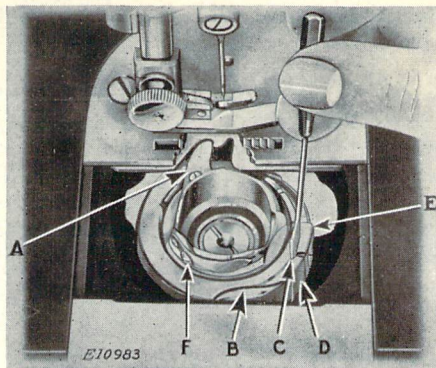

Fig. 36. Bobbin Case in Position.
(Throat Plate broken away to show correct
location of Finger A).

front of machine, as shown. Insert the blade of the small screw driver into slot C between the ring and the edge of spring, as shown. With a downward pressure,

give the screwdriver one half turn to the right so that it will drop into the slot and unlock the spring.

With the right hand hold the hand wheel to prevent its turning and, with the left, place the screwdriver against the edge of the slot in the ring and push it around in the direction opposite to the hook rotation until the circular cut-out **B** is opposite the spring **D**. The ring and bobbin case may then be lifted out.

make sure that it is properly seated, then place the hook ring **E** in position with the cut-out **B** opposite the spring **D**. Press the ring into place and turn it in the direction of hook rotation until the spring locks it in position. Then replace the bobbin.

TO REPLACE BOBBIN CASE

See Fig. 36.

When replacing the parts, first place the bobbin case into position with the finger **A** in the opening in the plate under the feed dog, as shown. Turn the bobbin case back and forth slightly to

Instructions for using The Attachments

NOTE.—Before applying any of these attachments raise the needle and remove the presser foot. After substituting the attachment turn the hand wheel slowly toward you to make sure that the needle passes through the centre of the needle hole. Pull up bobbin thread as instructed on page 17.

FOOT HEMMER

The Foot Hemmer **Fig. 37** may be used for hemming edge of material, making hemmed and felled seams and for hemming and sewing on lace in one operation.

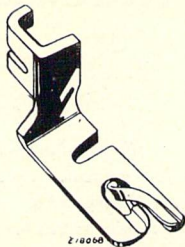

Fig. 37. The Foot Hemmer.

HOW TO START THE HEM AT THE VERY EDGE

How to start the hem at the very edge of the material is of great importance in learning to use the hemmer. If the hem is not started at the edge and the material is pulled bias, a perfect hem cannot be made.

There are several ways of starting the hem at the edge, but the most practical one is as follows :

1. Fold edge of material twice, about $\frac{1}{8}$ inch each time, for a distance of about two inches. Crease folds.
2. Lay about three inches of needle and bobbin threads back under hemmer. Place creased edge of material

under hemmer with end of hem directly under needle. Lower hemmer and tack end of hem with two machine stitches.

3. Raise hemmer. Pull threads and hem slightly from you with left hand ; then, while holding threads, draw material toward you with right hand into scroll of hemmer until tacked end is caught in hemmer, as shown in **Fig. 38.**

4. Lower the hemmer and begin to sew, slightly pulling threads back while sewing. **Keep mouth of hemmer full** to produce a smooth, even hem, as shown in **Fig. 39.**

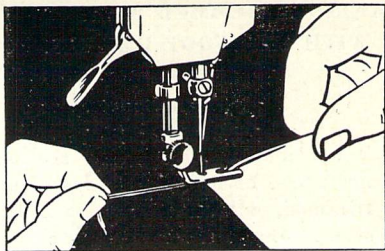

Fig. 38. Starting a Hem at the Edge.

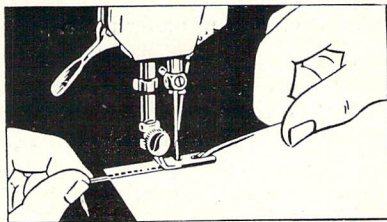
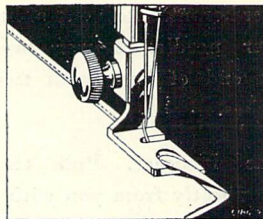

Fig. 39. Hemming Edge of Material and Pulling Back Threads While Sewing.

MAKING A HEMMED SEAM WITH THE FOOT HEMMER

See Figs. 40 and 41.

1. When making this seam, the garment must first be fitted and edge of material trimmed, allowing for about $\frac{1}{8}$ inch seam. Insert the two edges of material, right sides together, in hemmer in same manner as a single hem, as shown in **Fig. 40**. If material is bulky, place edge of upper piece of material about $\frac{1}{8}$ inch to left of edge of under piece.
2. The free edge of the hemmed seam may be stitched flat to the garment, if desired, To do this, open work out flat, wrong side up, then insert hem in scroll of hemmer, holding edge of hem in position while it is being stitched. If seam is stitched flat to garment, one row of stitching is visible on the right side.



*Fig. 40. Making a Hemmed Seam
(First Operation).*

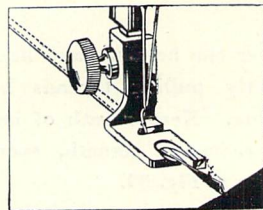

*Fig. 41. Making a Hemmed Seam
(Second Operation).*

MAKING A FELLED SEAM WITH THE FOOT HEMMER

See Figs. 42 and 43.

1. Place right sides of material together, having edge of upper piece about $\frac{1}{8}$ inch to left of edge of under piece. Stitch the two pieces together, using

hemmer as a presser foot. Guide both pieces by the projecting toe of hemmer, as shown in **Fig. 42**.

2. Open work out flat, wrong side up, and hem free edge of seam, stitching it flat to garment as shown in **Fig. 43**.

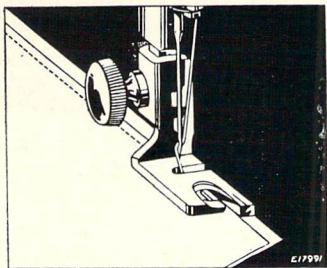

*Fig. 42. Making a Felled Seam
(First Operation).*

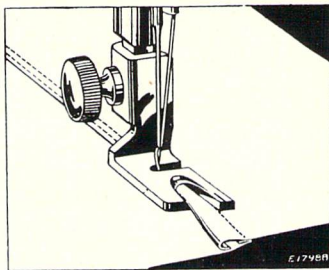
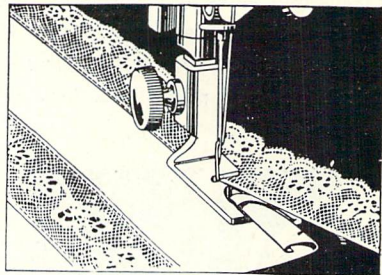

*Fig. 43. Making a Felled Seam
(Second Operation).*

TO HEM AND SEW ON LACE IN ONE OPERATION

See Fig. 44.

1. Start hem in the regular way.
2. Hold hem in position with needle.
3. Raise presser bar and insert edge of lace in slot of hemmer and back under hemmer.
4. Lower presser bar and start sewing, catching edge of lace with needle.
5. Guide hem with the right hand and lace with the left hand, being careful not to stretch lace as it enters hemmer.



*Fig. 44. Hemming and Sewing-on Lace
in One Operation.*

ADJUSTABLE HEMMER

HOW TO MAKE HEMS FROM $\frac{3}{16}$ " TO $\frac{15}{16}$ " WIDE

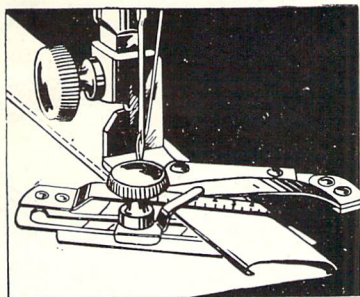

Fig. 45. Showing How Adjustable Hemmer is Used for Making Hems Up to $\frac{15}{16}$ Inch Wide.

1. Loosen the thumb screw on the hemmer and move the scale until the pointer registers with the number of the desired width of hem; No. 1 indicating the narrowest hem and No. 8, the widest; then tighten the thumb screw.
2. Place the cloth in the hemmer and draw it back and forth until the hem is formed, as shown in Fig. 45.
3. Draw the end of the hem back under the needle, lower the presser bar and start to sew.
4. Guide sufficient cloth into the hemmer to turn the hem properly.

ADJUSTABLE HEMMER

HOW TO MAKE HEMS WIDER

THAN $\frac{15}{16}$ "

1. Loosen the thumb screw on the hemmer, move the scale to the right as far as it will go, then swing it toward you, as shown in Fig. 46, and tighten the thumb screw.
2. Fold the crease the desired width of hem.
3. Place the fold under the extension at the right of the hemmer and the edge into the folder, as shown in Fig. 46.
4. Draw the end of the hem back under the needle, lower the presser bar and start to sew.
5. Guide the cloth to keep the hem flat.

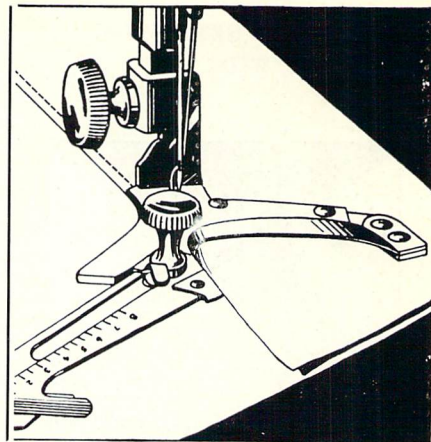

Fig. 46. Showing How Adjustable Hemmer is Used for Making Hems Wider than $\frac{15}{16}$ Inch.

BINDER

Pass the binding through the scroll of the binder and draw it under the needle. Place the edge of the material to be bound between the scroll of the binder and under the needle, lower the presser bar lifter and sew as usual.

Bias binding should be cut $\frac{15}{16}$ inch wide.

To Bind with Dress Braid.—Proceed as when using bias binding; but as dress braid and binding purchased already folded are narrower than bias binding they should be inserted in the outer slot of the binder. The edges of dress braid are not turned under as in the case of bias binding.

To make French Folds.—Proceed as directed for binding, but pass the cloth beneath the binder foot, so that the fold is stitched on to the face of the material instead of on the edge.

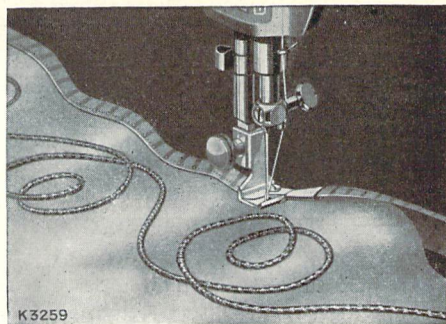

Fig. 47.

THE ADJUSTMENT AND OPERATION OF THE BINDER

The edge to be bound should be held well within the centre slot of the scroll, and with a little practice this is quite easy.

If the material is allowed to slip away from the scroll when near the needle, the edge will not be caught in the binding.

Various materials and conditions require different adjustments of the Binder to bring the stitching close to the edge. A wider adjustment of the Binder is necessary when binding curves than when binding a straight edge.

To adjust the Binder, loosen its small screw and move the scroll to the right for a narrower adjustment or to the left for a wider adjustment, after which securely tighten the screw. To become perfectly familiar with the adjustment of the Binder, a little practice is necessary.

BINDING OUTSIDE CURVES

Practice is required to bind a curved edge properly. The edge to be bound must be allowed to pass freely through the scroll and should not be crowded in or against it. Guiding should be from the back of the binder and to the left, allowing unfinished edges to swing naturally into the scroll of the binder. Never pull the binding as it feeds through the Binder, as bias material is very easily stretched and would be too narrow when it reaches the needle. If this occurs the edges will not be turned.

When binding a curved edge, turn the material only as fast as the machine sews. It is not possible to hold the

material in the entire length of the scroll when binding a small curve. Do not push the material in too fast, as the edge will then become puckered, and do not stretch the material or the curve will not be the proper shape when finished. If the stitching does not catch the edge of the binding the scroll should be adjusted a little to the left.

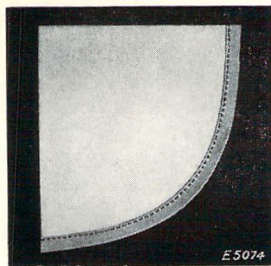

*Fig. 48. Sample of
Outside Curve.*

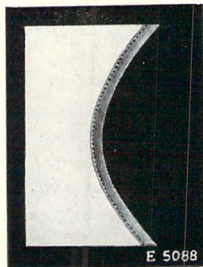

*Fig. 49. Sample of
Inside Curve.*

BINDING INSIDE CURVES

This curve is found on nearly all garments which are finished with a bound edge, but practice is necessary on various materials.

When binding an inside curve, straighten out the edge as it is being fed into the Binder. When doing this, take care not to stretch the edge of the material.

If the material is soft, like batiste or crepe de chine, add a row of machine stitching close to the edge of the curve before binding.

EDGE-STITCHER

A Combined Edge-Stitching, Lace-Joining and Piping Attachment

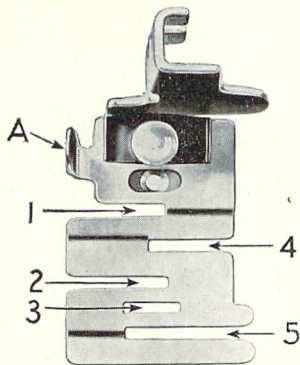

Fig. 50. The Edge-Stitcher.

This attachment is an indispensable aid whenever stitching must be kept

accurately on the extreme edge of a piece of material. The slots, numbered from 1 to 5 in **Fig. 50**, serve as guides for sewing together laces, insertions and embroideries, sewing in position hemmed or folded edges, piping or sewing flat braid to a garment.

ADJUSTING THE EDGE-STITCHER

After attaching the edge-stitcher to the machine, turn the hand wheel slowly by hand to see that the needle goes through the centre of the needle hole. The distance of the line of stitching from the edge of the material in the slots can be regulated by pushing the lug **A**, **Fig. 50** to the right or to the left. If it moves hard, put a drop of oil under the blue spring, then wipe it dry.

SEWING LACE TOGETHER WITH THE EDGE-STITCHER

It is difficult to sew two lace edges together even after basting, but the edge-stitcher makes it possible to stitch on the very edge. Place one edge in slot 1 and the other in slot 4, and adjust lug A, Fig. 50 until both edges are caught by the stitching. Hold the two pieces slightly overlapped to keep them against the ends of the slots. The thread tensions should be loose to avoid puckering of fine lace.

Lace and ribbon or other insertions can be set in by using the same slots (1 and 4). The material may be folded over before placing it in the slot so that

a double thickness is stitched and will not pull out. The surplus material is trimmed away close to the stitching as shown in Fig. 52.

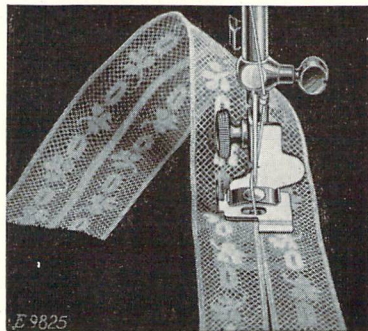

Fig. 51. Sewing Lace Together.

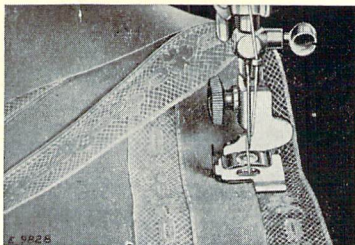

Fig. 52. Setting-in Lace Insertion.

PIPING WITH THE EDGE-STITCHER

See Fig. 53.

Piping is very attractive if the correct contrasting colour is chosen for the piping material. Place the piping, with its finished edge to the left, in slot 3, **Fig. 50**. Place the edge to be piped in

slot 4. Piping should preferably be cut bias, and should be cut to twice the width of the slot 3, **Fig. 50** in the edge-stitcher so that it can be folded once.

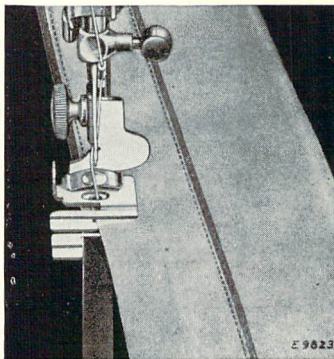

Fig. 53. Piping with the Edge-Stitcher.

APPLYING BIAS FOLDS WITH THE EDGE-STITCHER

Folded bias tape or military braid, used for neat and colourful trimming, may be sewn on by placing the garment under the edge-stitcher the same as under the presser foot, and placing the tape in slot 1 or 4, **Fig. 50**. To make a square corner, sew until the turning point is reached, then remove the tape from the attachment and form the corner by hand, replace it in the slot and continue stitching, as shown in **Fig. 54**. To space two or more parallel rows, a guide line such as a crease, chalk mark or basting thread should be used.

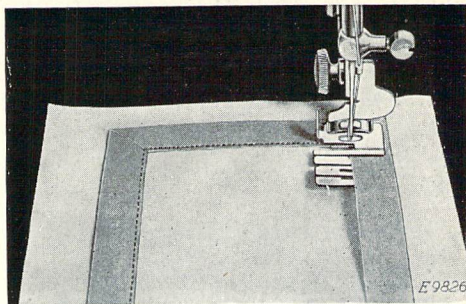

Fig. 54. Applying Bias Folds with the Edge-Stitcher.

STITCHING A WIDE HEM WITH THE EDGE-STITCHER

A wide hem on sheets, pillow slips, etc., may be stitched evenly with the edge-stitcher after the hem has been measured and the edge turned. Insert the edge in slot 5, Fig. 50 and adjust to stitch as close to the edge as desired, as shown in Fig. 55.

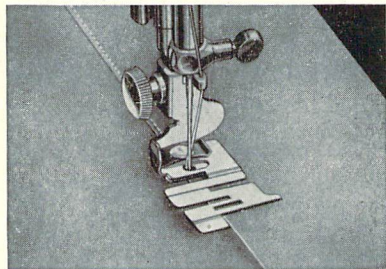

Fig. 55. Making a Wide Hem.

MAKING A FRENCH SEAM

An even French seam may be made by inserting the two edges to be joined, wrong sides together, in slot 1 or 2 and stitching close to the edge; then folding both right sides together and inserting the back of the seam into slot 1 again and stitching with just enough margin to conceal the raw edges (See Fig. 56).

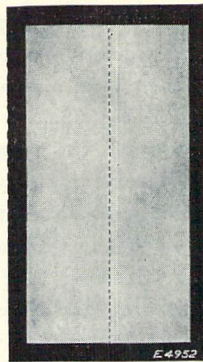

Fig. 56. A French Seam.

TUCKING WITH THE EDGE-STITCHER

See Fig. 57.

Dainty narrow tucking may be produced on the edge-stitcher by inserting creased folds in slot 1 and adjusting the edge-stitcher to the right or left for the desired width of tuck, up to $\frac{1}{8}$ inch. Successive tucks may be easily creased by folding the material at the desired distance from the previous tuck, and then running the length of the fold over a straight edge such as the edge of the sewing machine cabinet. The secret of good tucking lies in a light tension, short stitch and fine thread and needle.

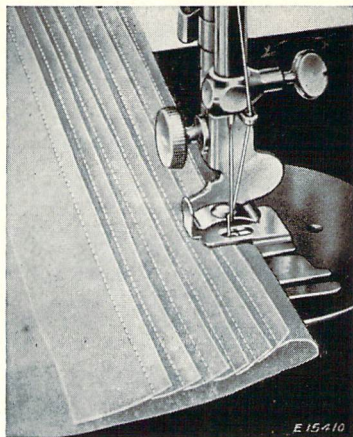

Fig. 57. Tucking with the Edge-Stitcher.

GATHERING FOOT

To Shirr with the Gathering Foot

Material placed under the gathering foot and stitched in the usual way will be slightly gathered. Any fabric that drapes well is especially suited

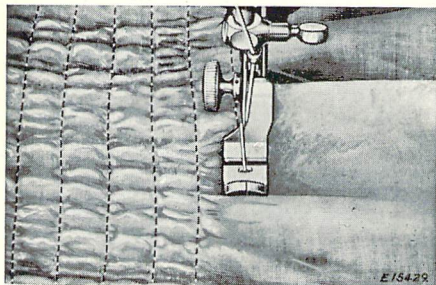

Fig. 58. The Gathering Foot in Operation.

for shirring with the gathering foot. Most shirring with the gathering foot is done with a long stitch and tight tension. To increase the fullness of the gathers, lengthen the stitch. To decrease the fullness, shorten the stitch.

With the gathering foot, it is possible to shirr in narrow rows, as shown in **Fig. 58**. The material may be guided as easily as when sewing with the presser foot. Fine materials, such as batiste, silk or net, may be very attractively shirred, as shown by the sample in **Fig. 59**. Where only a slight fullness is required, as at the top of a sleeve or around the neck, the gathering foot will be found very convenient.

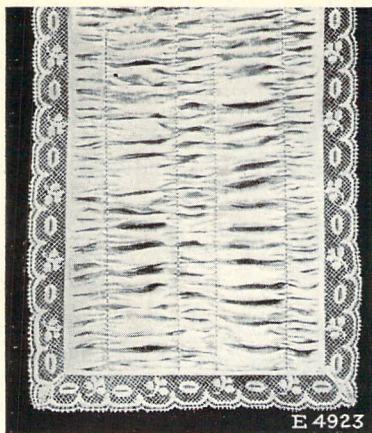

Fig. 59. Shirring.

A very pleasing effect may be gained by using thread or embroidery silk of contrasting colour on the bobbin. **Fig. 60** shows a white organdie collar and

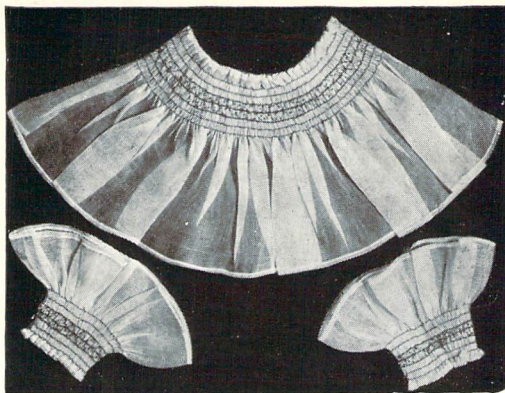

Fig. 60. Smocking.

cuff set with red and green smocking made with the gathering foot, using fine crochet cotton or tating thread on the top and white cotton on the bobbin.

RUFFLER

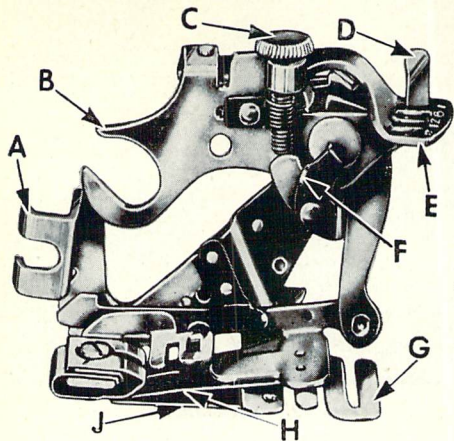

Fig. 61. *Principal Parts of the Ruffler.*

Principal Parts of the Ruffler

A—Foot—attaches ruffler to presser bar.

B—Fork Arm—straddles needle clamp.

C—Adjusting Screw—regulates fullness of gathers.

D—Projection—engages slots in adjusting lever.

E—Adjusting Lever—sets ruffler for gathering or for making a pleat once at every six stitches or once every twelve stitches, as desired, also for disengaging ruffler, when either pleating or gathering is not desired.

F—Adjusting Finger—regulates width or size of pleats.

G—Separator Guide—contains slots into which edge of material is placed to

keep heading of ruffle even ; also for separating material to be ruffled from material to which ruffle is to be attached.

H—Ruffling Blade—pushes material in pleats up to the needle.

J—Separator Blade—prevents teeth of ruffling blade from coming into contact with feed of machine or material to which ruffle or pleating is to be applied.

TO ATTACH THE RUFFLER TO THE MACHINE

Loosen presser foot thumb screw and attach ruffler to presser bar, at the same time placing fork arm **B** astride the needle clamp.

TO ADJUST RUFFLER FOR GATHERING

1. Swing adjusting finger **F** away from needle.
2. Raise adjusting lever **E** and move it until projection **D** can be entered in slot marked "1."

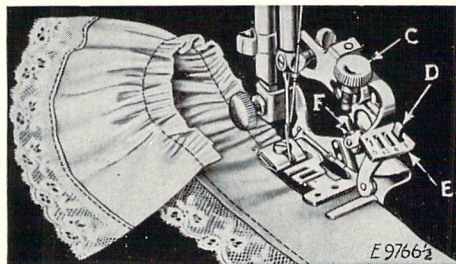

Fig. 62. Gathering with the Ruffler.

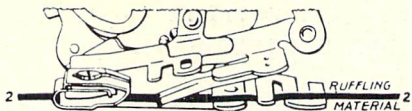

Fig. 63. Correct Position for Material to be Ruffled.

3. Insert material to be ruffled between two blue blades and under separator guide (Line 2, Fig. 63).
4. Draw material slightly back of needle, lower presser bar and start to sew.
5. For fine gathering, turn adjusting screw **C** upward to shorten stroke. Set the machine for a shorter stitch.
6. For full gathering, turn adjusting screw **C** downward to lengthen stroke. Set the machine for a longer stitch.

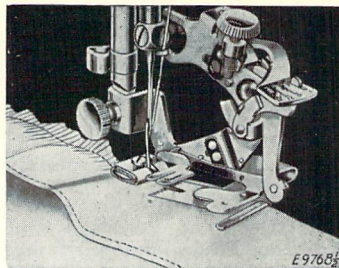

Fig. 64. Making a Ruffle and Attaching it in One Operation.

TO MAKE A RUFFLE AND SEW IT TO A GARMENT IN ONE OPERATION

1. Insert material to be ruffled between two blue blades and under separator guide (Line 2, Fig. 65).

2. Place material to which ruffle is to be attached under separator blade and under separator guide (Line 1, Fig. 65).
3. Proceed the same as for plain gathering.

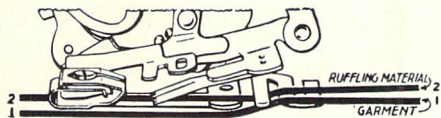

Fig. 65. Correct Positions for Materials.

TO MAKE A RUFFLE AND ATTACH IT WITH A FACING IN ONE OPERATION

1. Insert material to be ruffled between two blue blades and under separator guide (Line 2, Fig. 67).

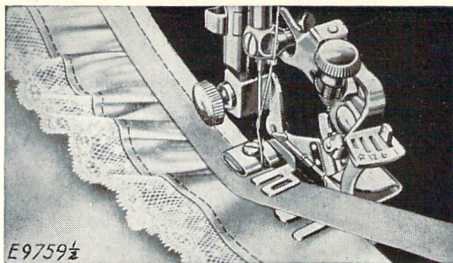

Fig. 66. Making a Ruffle and Attaching it with a Facing in One Operation.

2. Place material to which ruffle is to be attached under separator guide (Line 1, Fig. 67).
3. Place facing material over upper blue blade (Line 4, Fig. 67).
4. If facing is to be on **right side** of garment, place wrong sides of garment and ruffle together.



Fig. 67. *Correct Positions for Materials.*

5. If facing is to be on **wrong side**, place right sides of garment and ruffle together.

TO PIPE A RUFFLE

1. Insert material to be ruffled between two blue blades from the right (Line 3, Fig. 69). This material must not exceed $1\frac{1}{4}$ inches in width.
2. The piping material is usually cut on the bias and it should be about

$\frac{1}{4}$ inch wide when folded in centre. Place piping material in ruffler, following Line 5, Fig. 69 with folded edge of piping to right.

3. Fold edge of material to which piping and ruffling are to be attached and

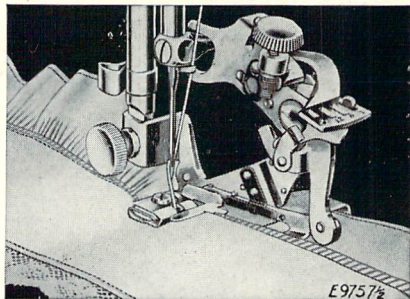

Fig. 68. *Piping a Ruffle.*



Fig. 69. Correct Positions for Materials.

insert it in ruffler, from the left following Line 6, Fig. 69.

TO ADJUST RUFFLER FOR PLEATING

1. Raise adjusting lever E and move it until projection D can be entered in slot marked "6." The ruffler will then pleat once every six stitches. To pleat once every twelve stitches,

have projection D enter slot "12" in the adjusting lever E.

2. Insert the material to be pleated between the two blue blades and under the separator guide (Line 2, Fig. 71).
3. To increase width of pleat, move adjusting finger F back toward needle and turn adjusting screw C downward.

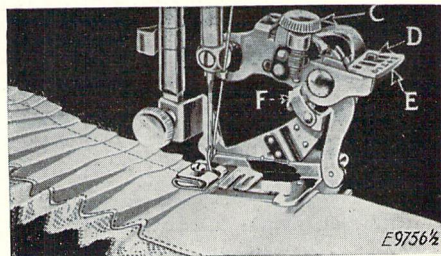

Fig. 70. Pleating with the Ruffler.

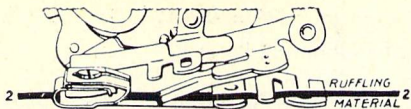

Fig. 71. Correct Positions for Material.

To make a smaller pleat, turn adjusting screw **C** upward. The distance between pleats is regulated by length of stitch.

TO ADJUST RUFFLER FOR GROUP PLEATING

1. To make the space between the groups of pleats, raise adjusting lever **E** and move it until projection **D** can be entered in small slot indicated by

star on adjusting lever **E**. The ruffler will then stop pleating and plain stitching will be made.

2. When the desired space is made, set projection **D** in either of slots "6" or "12."

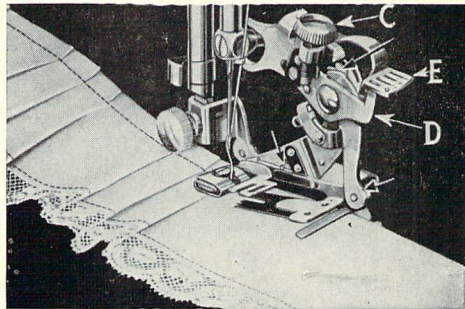

Fig. 72. Group Pleating with the Ruffler.

3. Insert the material to be pleated between the two blue blades and under the separator guide (Line 2, Fig. 73).

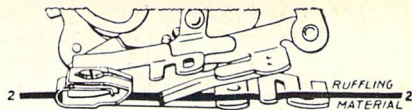
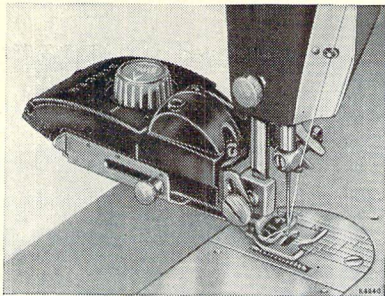

Fig. 73. Correct Position for Material.

TO OIL THE RUFFLER

Occasionally apply a drop of oil to the working parts of the ruffler at the places indicated by the unlettered arrows in Fig. 72.



AUTOMATIC ZIGZAGGER





Zigzag stitching, decorative pattern stitching, applique—all of these and more may be done AUTOMATICALLY on your SINGER with the Automatic Zigzag Attachment. You can blindstitch hems, mend rips and tears, reinforce seams, overedge seam edges and stitch scallop facing easily and quickly.

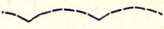

Merely insert one of the many Stitch Patterns into the Automatic Zigzagger and sew.

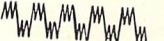

Zigzag   *Key*

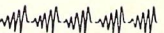
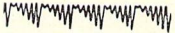

*Blind
Stitch*   *Ball*

Domino   *Block*

*Arrow
Head*   *Shingle*

Scallop   *Curved
Mending*

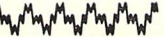
Multiple   *Open
Scallop*

*Walls of
Troy*   *Three-
Step*

Icicle   *Solid
Scallop*

THE BUTTONHOLER

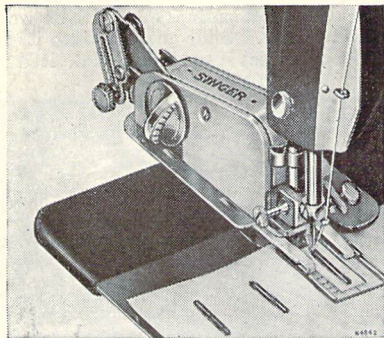

Beautiful, evenly stitched buttonholes may be made on your SINGER Machine with the Buttonholer, as easily as you do straight stitching.

The Buttonholer does the work for you—straight buttonholes from $\frac{3}{8}$ to one inch long.

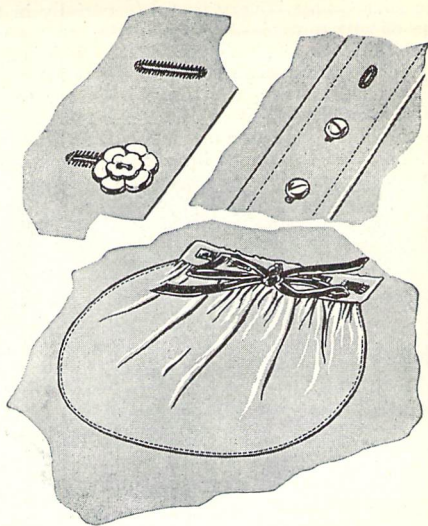

*Samples of Work Produced by SINGER
Buttonholer.*

BIAS GAUGE

The Bias Gauge is very useful (especially in the case of soft materials) when cutting bias strips from $\frac{7}{16}$ inch to $1\frac{3}{8}$ inches in width. This is done by placing the bias gauge upon the point of the scissors and setting the blued indicator to the width desired. The line **F** is the point at which to set the blued indicator for facings, the line **B** for binding, and the line **C** for cording or piping.

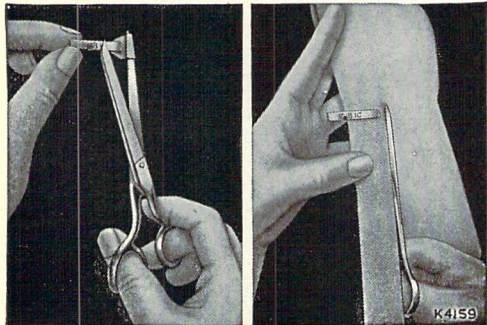

Insert the material in the gauge with the edge against the blued indicator, and hold as shown above.

Bias binding should be cut $\frac{1}{8}$ inch wide, and to do this the indicator should be set midway between the lines **F** and **B**.

THE QUILTER

The quilter guide can be used at either the right or left of the needle, and the distance of the guide from the needle determines the width between the rows of stitching. Slide the wire into its holder on the foot, and set it to the width desired; then lower the foot on to the material.

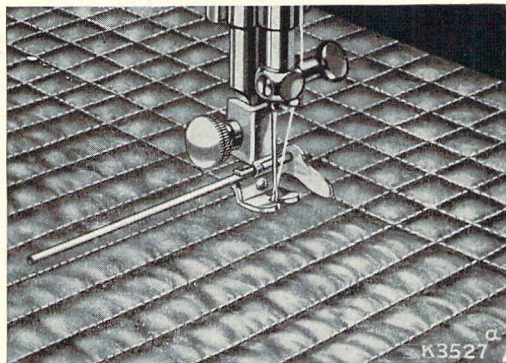

To Quilt.—For the first row of stitching, let the quilter guide follow the edge of the material, a straight crease, or a line, as preferred. Succeeding rows are made straight, and at a uniform distance, by keeping the previous row steadily under the guide, as shown.

SEAM GUIDE

The Seam Guide is helpful when stitching seams an exact width, and for stitching a uniform distance from a finished edge. Especially helpful for those just learning to sew and an aid to those demanding greater uniformity in seam width than the eye might give, the Seam Guide is a useful addition to your sewing equipment.

TUCKER

The Tucker is a time-saver for making tucks up to one inch in width. Two adjustable scales are provided, the smaller near the needle is numbered from 1 to 8, expressing in eighths of an inch the width of the tuck. The larger scale expresses in quarter inches the spacing between tucks.

Set the tuck scale first for the width of tuck. The space scale is then adjusted using the needle as an indicator for the spacing between tucks. When both scales are set at the same number, blind tucks result. That is, the fold of one tuck just touches the stitching line of the next. When additional space between tucks is desired, adjust the space scale to a point beyond the tuck scale reading equal to the spacing desired, expressed in quarters of an inch. Thus half-inch tucks spaced a half inch apart require a tuck scale setting of 4, and a space scale setting of 6.

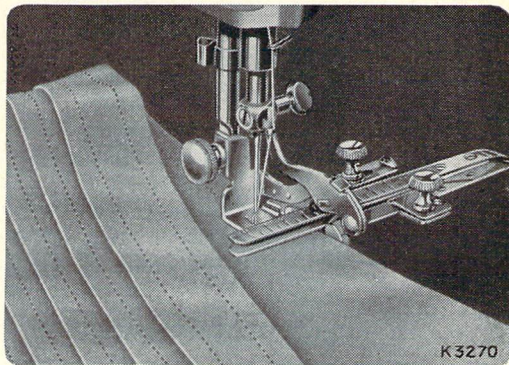

THE ZIPPER FOOT

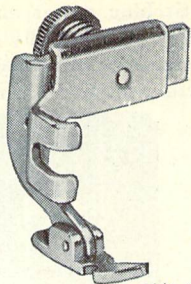

K4844

This foot is designed to facilitate the placement of stitching close to a raised edge. It is attached to machine in place of the regular presser foot and may be adjusted to either the right or left side of the needle, without removing it from the machine.

APPLICATIONS

Zipper Insertion
Corded Seams
Tubular Cording

Slip Cover Welting
Shirred Cording
Corded Headings

“The Best is the Cheapest”

Use **SINGER** SEWING MACHINE OIL on Machine

Knowing from many years' experience the great importance of using good oil, **SINGER** sells an extra quality sewing machine oil, in cans, especially prepared for sewing machines.

SINGER Needles should be used
in SINGER Machines.

These Needles and their Containers
are marked with the Company's
Trade Mark SIMANCO.*

Needles in Containers marked
“FOR SINGER MACHINES”
are NOT
SINGER made Needles.

INDEX

	Page		Page
Attachments		Fashion Aids	64
Adjustable Hemmer	43	Bias Gauge	66
Binder	45	Buttonholer	65
Edge-Stitcher	48	Quilter	66
Foot Hemmer.....	38	Seam Guide	67
Gathering Foot	54	Tucker	67
Ruffler	56	Zigzagger, Automatic	64
Belt Shifter	9	Zipper Foot	68
Bobbin		Hand Attachment	8
Removing	13	Light	5
Replacing	15	Lubrication	
Winding	13	To Oil the Machine and Stand	32
Bobbin Case		To Oil the Sewing Hook	33
Removing	35	Needles and Thread	11
Replacing	36	Needle Setting	10
Threading	15	Presser Foot, to Regulate Pressure	21
Bobbin Winder	13	Rust damage, prevention of	31
Darning and Embroidery	29	Service, SINGER	3
Electrical Information	4		

INDEX—continued.

	Page		Page
Sewing		Threading	
To Operate Electric Machine	7	Upper Threading	12
To Operate Hand Machine	8	Bobbin Case Threading	15
To Operate Treadle Machine	9	Thread Tensions	21
To Prepare for Sewing	17	Bobbin Thread Tension,	
To Start Sewing	18	to Regulate	23
To Turn a Corner	19	Needle Thread Tension,	
Basting	19	to Regulate	22
To Sew Bias Seams	19	Needle Thread Tension,	
To Remove the Work	20	to Adjust.....	26
To Regulate Length of Stitch and		Needle Thread Tension,	
Direction of Feed.....	20	to Disassemble	24
Sewing Suggestions	30	Needle Thread Tension,	
Stitch Forming Mechanism,		to Reassemble	25
Cleaning	35	Thread Take-up Spring,	
Stop Motion	9	to Adjust Tension	27

TO ALL WHOM IT MAY CONCERN :

The improper placing or renewal of the Trade Mark "SINGER" or any other of the Trade Marks of The Singer Manufacturing Company (all of which are duly Registered Trade Marks) on any machine that has been repaired, rebuilt, reconditioned, or altered in any way whatsoever outside a SINGER factory or an authorised SINGER agency is forbidden.

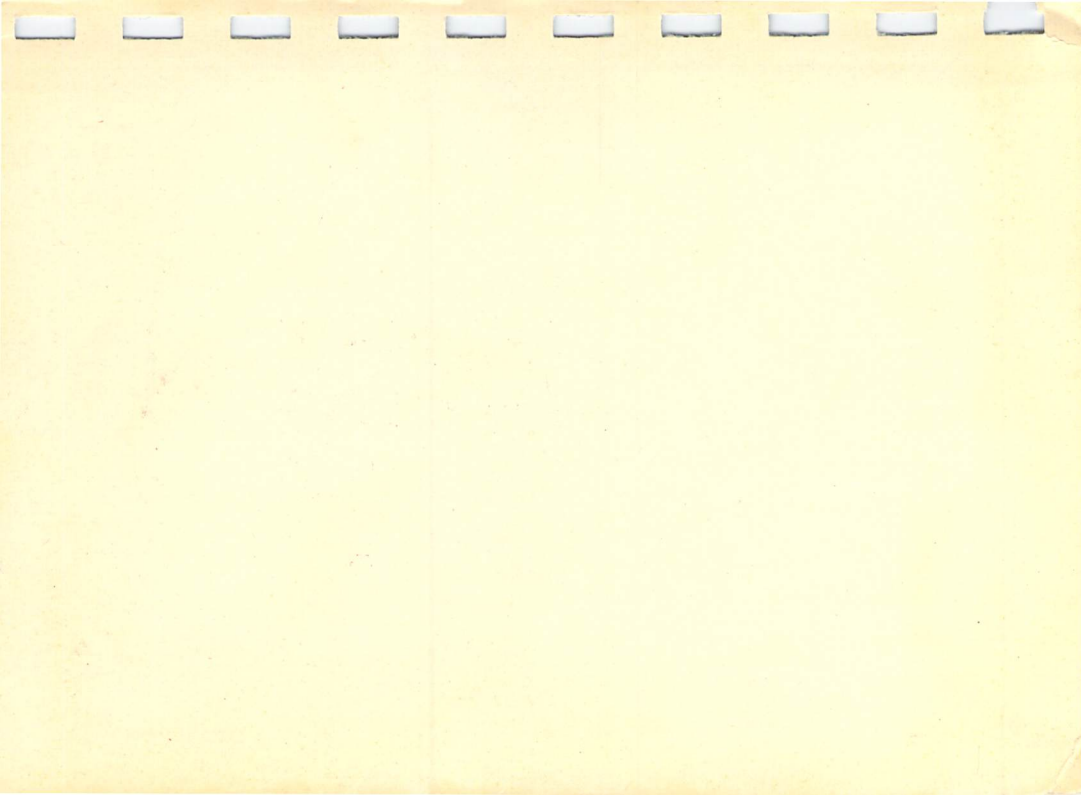



For your protection

ALWAYS LOOK FOR THE FAMOUS RED "S" AND SINGER TRADEMARKS FOR AUTHORISED SALES AND SERVICE.

WHEN YOUR MACHINE NEEDS SERVICING, CALL YOUR SINGER SEWING CENTRE AND BE SURE OF WARRANTED SINGER PARTS AND SERVICE.

SEE ADDRESS IN CLASSIFIED TELEPHONE DIRECTORY LISTED ONLY UNDER

SINGER SEWING MACHINE COMPANY