

San Luis Obispo, California, 93401
Phone 805.541.1601
800.676.1335
Fax 805.541.8459
www.delozone.com

EPA Estab. No. 071472-CA-001

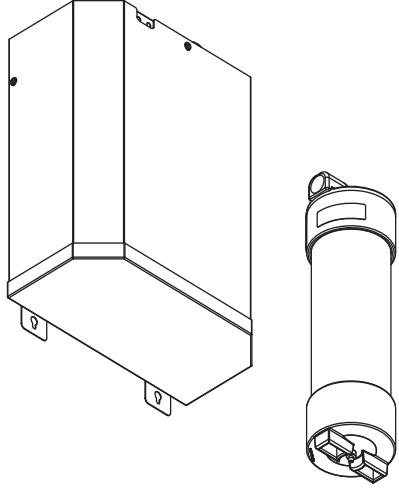

Total Eclipse 2 and Total Eclipse 4
Flip Booklet for EC-1, EC-2, and EC-4 Applications

Installation Manual for MDV Mixing Degas Vessel (MDV)

Installation Manual for MDV Mixing Degas Vessel (MDV)

EC-1, EC-2, and EC-4
Flip Booklet for Total Eclipse Applications

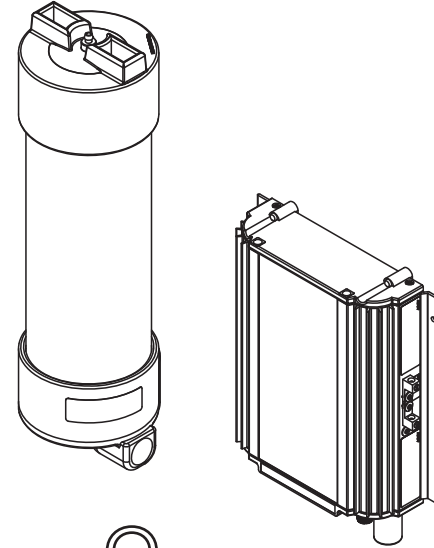

EPA Estab. No. 071472-CA-001

San Luis Obispo, California, 93401
Phone 805.541.1601
800.676.1335
Fax 805.541.8459
www.delozone.com

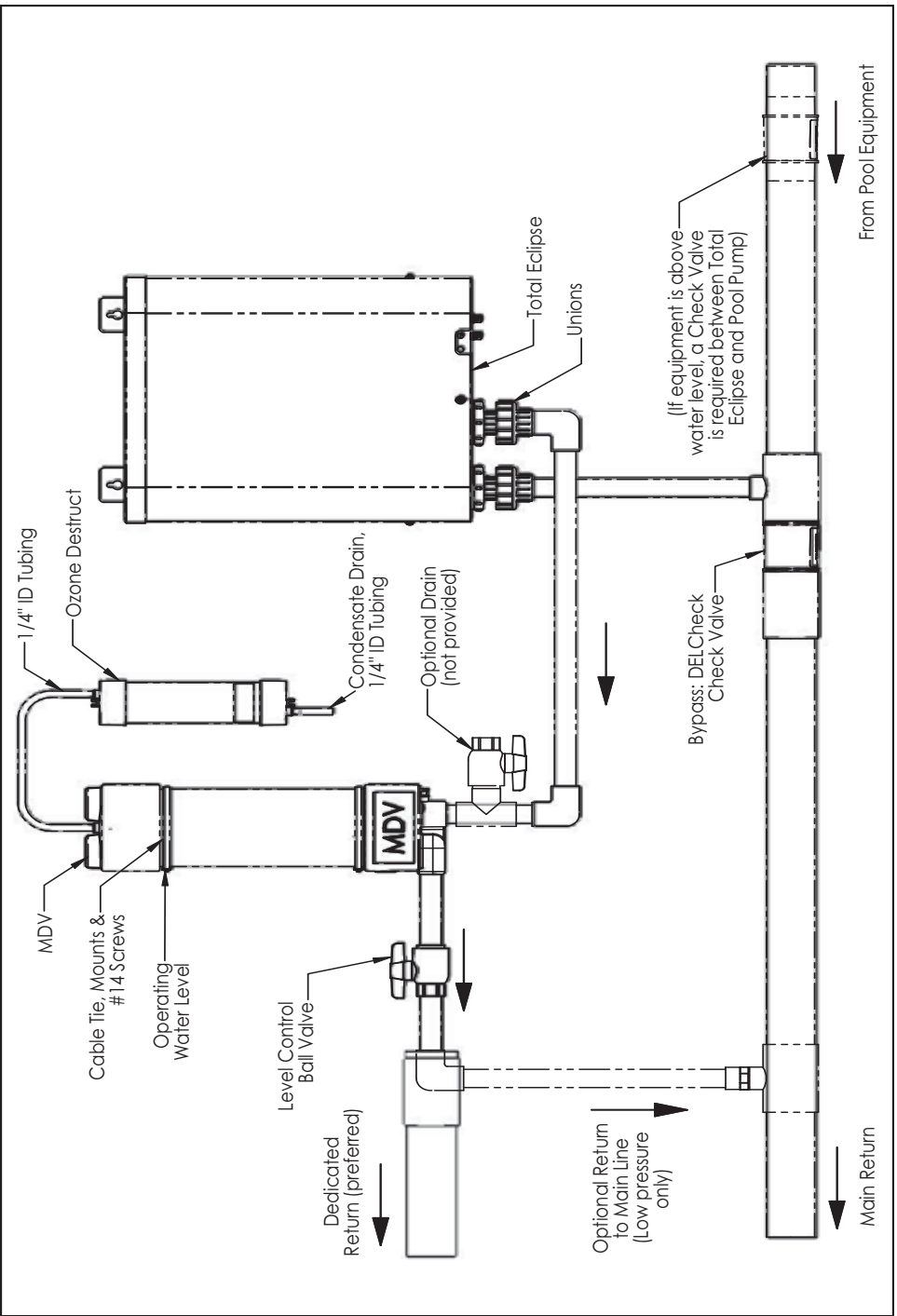

Figure 2: MDV and Total Eclipse Installation

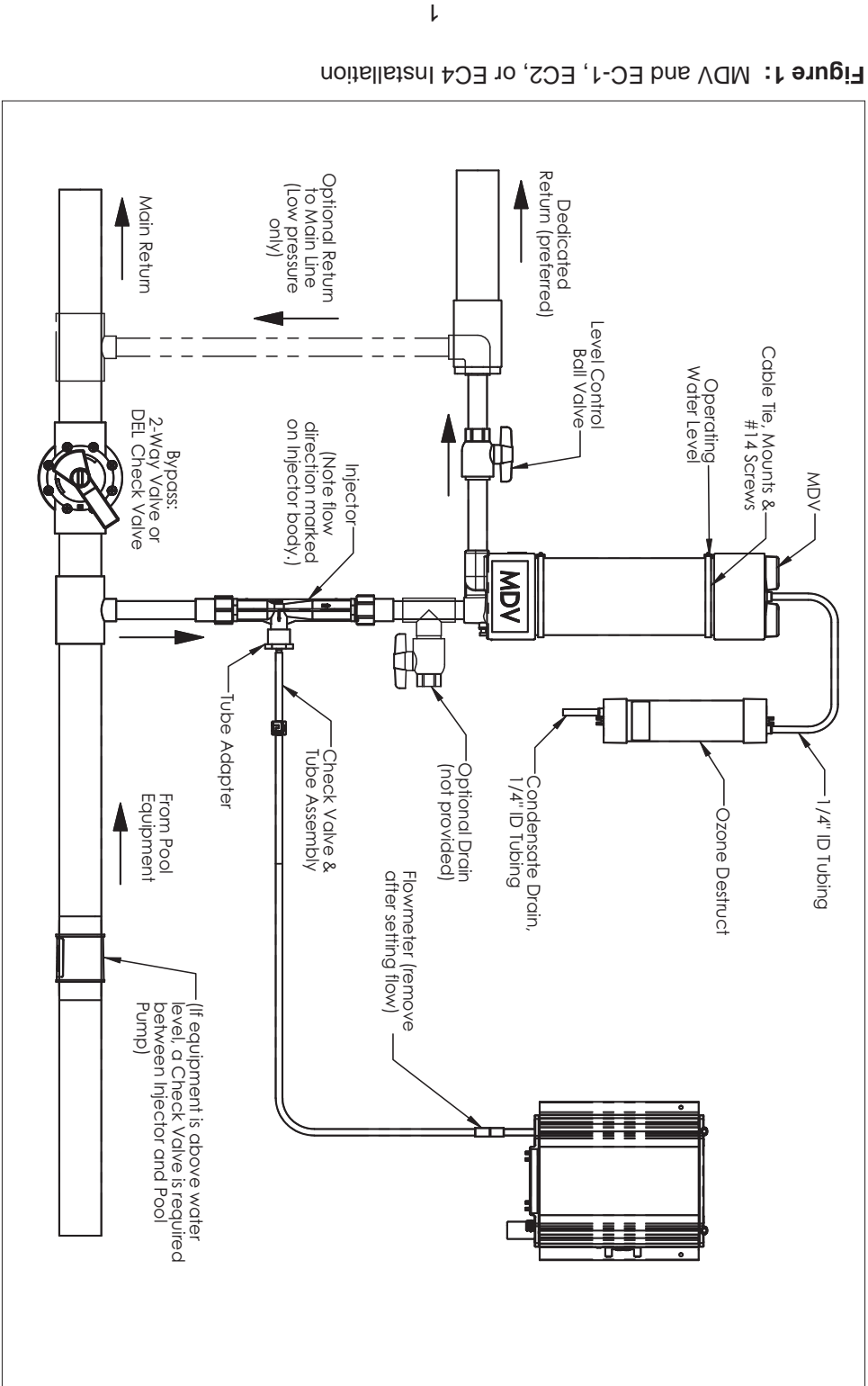

Figure 1: MDV and EC-1, EC2, or EC4 Installation

General Information

The DEL MDV (Mixing Degas Vessel) system:

- Prevents virtually all ozone bubbles from returning to the pool, eliminating bubble noise and visibility.
- Allows application of higher ozone concentrations.
- Protects pool components such as covers, fittings and surfaces.
- Prevents bubbles from gathering under the cover or inside plumbing.
- Utilizes a Granulated Activated Carbon (GAC) destruct cartridge to destroy excess ozone gas removed by the MDV.

Installation (refer to Figure 2)

NOTE: The MDV will not be as effective in systems with back pressures in excess of 10 psi. Oversized pumps and small returns should be avoided.

1. Follow ozone generator mounting and electrical connection instructions in Total Eclipse manual.
 2. Mount the MDV vertically as shown in **Figure 2** to a solid surface (i.e. fence, wall, post) using the (2) cable ties, (4) cable tie mounts, and (4) screws included. Use a pair of pliers to tighten and secure the cable tie. If trimming away excess, fold tab over to avoid the sharp edge. To avoid discoloration, mount in an area out of direct sunlight.
 3. Mount the GAC Cartridge vertically to a flat surface using 2 #6 screws. **NOTE:** Mount the cartridge close enough to the MDV so that the tubing can be connected from the cartridge to the top of the MDV.
 4. Plumb the Total Eclipse and MDV to the pool return line as indicated in **Figure 2**. Use thread sealant as needed. **Do not use thread tape.**
- NOTE:** Be sure that the flow direction arrow on the Del Check is correctly oriented with the direction of water flow.
5. The recommended return configuration is a dedicated line from the MDV to the pool. If a dedicated return is not available, a return to the main line may be used.
 6. An additional valve may be installed either before or after the MDV to act as a drain for winterizing or maintenance.
 7. The drain at the base of the Destruct cartridge will release small amounts of condensation and carbon under normal operation. To avoid water or carbon stains, connect tubing to the bottom of the Destruct and divert the condensation to a suitable location.

General Information

The DEL MDV (Mixing Degas Vessel) system:

- Prevents virtually all ozone bubbles from returning to the pool, eliminating bubble noise and visibility.
- Allows application of higher ozone concentrations.
- Protects pool components such as covers, fittings and surfaces.
- Prevents bubbles from gathering under the cover or inside plumbing.
- Utilizes a Granulated Activated Carbon (GAC) destruct cartridge to destroy excess ozone gas removed by the MDV.

Installation (refer to Figure 1)

NOTE: The MDV will not be as effective in systems with back pressures in excess of 10 psi. Oversized pumps and small returns should be avoided.

1. Follow ozone generator mounting and electrical connection instructions in Eclipse manual.
2. Mount the MDV vertically as shown in Figure 1 to a solid surface (i.e. fence, wall, post) using the (2) cable ties, (4) cable tie mounts, and (4) screws included. Use a pair of pliers to tighten and secure the cable tie. If trimming away excess, fold tab over to avoid the sharp edge. To avoid discoloration, mount in an area out of direct sunlight.
3. Mount the (GAC) Cartridge vertically to a flat surface using (2) #6 screws. **NOTE:** Mount the cartridge close enough to the MDV so that the tubing can be connected from the cartridge to the top of the MDV.
4. Install By-Pass plumbing as shown in Figure 1. Use the appropriate By Pass Valve based on your pump type:
 - a. For Single Speed pumps install the adjustable 2-Way Valve.
 - b. For Two-Speed or Variable Speed pumps, install a DEL Check valve.
5. The recommended return configuration is a dedicated line from the MDV to the pool. If a dedicated return is not available, a return to the main line may be used.
6. An additional valve may be installed either before or after the MDV to act as a drain for winterizing or maintenance.
7. Screw the Tube Adapter onto the injector using thread sealant if needed. Do not use thread tape.
8. Connect the Ozone Tube Assembly to the Tube Adapter on the Injector. Be sure that the end with the check valve installed is connected to the Injector.
9. Attach the other end of the check valve and tubing assembly to the ozone outlet on the Eclipse. Be sure the flow direction is away from the Eclipse.

10. The drain at the base of the Destruct cartridge will release small amounts of condensation and carbon under normal operation. To avoid water or carbon stains, connect tubing to the bottom of the Destruct and divert the condensation to a suitable location.
11. Allow all PVC glue to dry completely per manufacturer's instructions before running water through MDV.

Operation

1. The gas flow must now be optimized. Refer to Section 3 of your Eclipse manual for instructions on adjusting water flow to achieve proper gas flow.
2. The water level inside the MDV should be near the bottom edge of the MDV Top Endcap. Use the Level Control Ball Valve installed at the MDV outlet to adjust the water level (see Troubleshooting section).
- NOTE:** For Variable Speed pumps, the water level in the MDV may drop completely at low speeds. The Level Control Ball Valve may be closed slightly to raise the level. However, this may impair injector performance at higher speeds. Verify proper operation under all conditions.
3. Streams of gas bubbles should be rising to the top of the MDV, and the water returning to the pool should be virtually bubble free.
4. If the pool equipment is mounted above water level, it is normal for water to drain from the MDV when the main circulation pump turns off. The MDV should return to normal operation shortly after the system comes back on.

Troubleshooting

- Symptom:** The water level in the tower is only around half full, or steadily dropping.
- There is not enough backpressure downstream of the MDV to maintain water level in the tower. -- **Plumb in a small ball valve downstream of the MDV. Close it off to the point where the proper water level in the tower is maintained.**
- Symptom:** Large bubbles are visible at the bottom of the tower, and are at the pool return.
- The gas flow rate is too high. -- **Reduce the gas flow through the injector, by slowly turning the handle on the Bypass Valve towards the open position. Ensure that the flow-meter ball is still bouncing in the flow meter.**

Maintenance

1. The MDV itself is maintenance free. The destruct cartridge must be replaced every 12 months of operation. A new cartridge can be ordered from your dealer/distributor using DEL part number 9-0620.
2. Winterizing, if necessary, can be done by draining water from MDV.

Replacement Parts

Hose Clamp for 1/4" ID tubing	2-0078
Check Valve and Tubing Assembly	9-0770-01
Cable Tie (for mounting MDV)	8-0668
Destruct Cartridge	9-0620

Operation

1. Begin with the Level Control Ball Valve in the half open position. Follow system start-up instructions in Total Eclipse manual. Turn off the pool's main circulation pump, and allow the Total Eclipse to run on its own. At this point water will be flowing through the MDV, but not filling up the tower.
2. Adjust the Level Control Ball Valve until the water level inside the MDV is near the top of the intersection of the clear PVC tower and the molded top cap.
3. Restart then shut down the pool's main circulation pump several times, ensuring that the water level in the tower remains at the top of the tower both when the main circulation pump is on and off.

Troubleshooting

Symptom: There is no water in my MDV.

The pump in your Total Eclipse has stopped running -- **Refer to the troubleshooting guide in your total eclipse manual.**

Maintenance

1. The MDV itself is maintenance free. The destruct cartridge must be replaced every 12 months of operation. A new cartridge can be ordered from your dealer/distributor using DEL part number 9-0620.
2. Winterizing, if necessary, can be done by draining water from MDV.

Replacement Parts

Hose Clamp for 1/4" ID tubing	2-0078
Check Valve and Tubing Assembly	9-0770-01
Cable Tie (for mounting MDV)	8-0668
Destruct Cartridge	9-0620

DEL OZONE LIMITED 1 YEAR WARRANTY

The limited warranty set forth below applies to products manufactured by DEL Ozone - 3428 Bullock Lane, San Luis Obispo, California 93401, and sold by DEL Ozone or its authorized dealers. This limited warranty is given only to the first retail purchaser of such products and is not transferable to any subsequent owners or purchasers of such products.

DEL Ozone warrants that it or its authorized dealers will repair or replace, at its option, any part of such products proven to be defective in materials or workmanship within ONE (1) year from the date of retail purchase of such products. (All parts) ANY REPAIR OR REPLACEMENT WILL BE WARRANTED ONLY FOR THE BALANCE OF THE ORIGINAL WARRANTY PERIOD OR 90 DAYS WHICH EVER IS LONGER.

NOTE: USE ONLY DEL Ozone AUTHORIZED REPLACEMENT PARTS. USE OF ANY OTHER PART(S) WILL AUTOMATICALLY VOID THIS WARRANTY.

Any replaced parts must be returned to DEL OZONE for warranty evaluation.

THIS LIMITED WARRANTY DOES NOT INCLUDE ANY OF THE FOLLOWING:

- (a) Any labor charges for troubleshooting, removal, or installation of such parts.
- (b) Any repair or replacement of such parts necessitated by faulty installation, improper maintenance, improper operation, misuse, abuse, negligence, accident, fire, repair materials, and/or unauthorized accessories.
- (c) Any such products installed without regard to required local codes and accepted trade practices;
- (d) ANY IMPLIED WARRANTY OF MERCHANTABILITY OR IMPLIED WARRANTY OF FITNESS FOR PARTICULAR PURPOSE, AND SUCH WARRANTIES ARE HEREBY DISCLAIMED.
- (e) DEL Ozone SHALL NOT BE LIABLE UNDER ANY CIRCUMSTANCES FOR LOSS OF USE OF SUCH PRODUCTS, LOST PROFITS, DIRECT DAMAGES, INDIRECT DAMAGES, CONSEQUENTIAL DAMAGES AND/OR INCIDENTAL DAMAGES.

TO OBTAIN WARRANTY SERVICE:

DEL Ozone Warranty Department
3428 Bullock Lane, San Luis Obispo, CA 93401
Customer Service Number: (800) 676-1335 x 293
Fax Number: (805) 541-8459
E mail to service@ delozone.com

When filing a claim, you must provide:

1. your name, mailing address and telephone number
2. the selling dealer's name
3. proof of date of purchase
4. the date of failure
5. a description of the failure
6. Part number and serial number / mfg date

After this information is provided, DEL Ozone may release a *RETURN GOODS AUTHORIZATION (RGA) NUMBER*. After receiving the RGA number the part in question must be returned to DEL Ozone, freight prepaid, with the RGA number clearly marked on the outside of the package. All preauthorized defective parts must be returned to DEL Ozone within thirty (30) days. Under no circumstances may any product be returned to DEL Ozone without prior authorization. Returns without the assigned RGA number on the outside of the package will be refused and shipped back to the sender at their expense. Upon receipt of preauthorized returned goods, DEL Ozone will repair or replace, at DEL Ozone's option, the defective product(s) and return them (freight prepaid for products under warranty). Buyer's acceptance of the product and use thereof constitutes acceptance of these terms.

After this information is provided, DEL Ozone may release a *RETURN GOODS AUTHORIZATION (RGA) NUMBER*. After receiving the RGA number the part in question must be returned to DEL Ozone, freight prepaid, with the RGA number clearly marked on the outside of the package. All preauthorized defective parts must be returned to DEL Ozone within thirty (30) days. Under no circumstances may any product be returned to DEL Ozone without prior authorization. Returns without the assigned RGA number on the outside of the package will be refused and shipped back to the sender at their expense. Upon receipt of preauthorized returned goods, DEL Ozone will repair or replace, at DEL Ozone's option, the defective product(s) and return them (freight prepaid for products under warranty). Buyer's acceptance of the product and use thereof constitutes acceptance of these terms.

1. your name, mailing address and telephone number
2. the selling dealer's name
3. proof of date of purchase
4. the date of failure
5. a description of the failure
6. Part number and serial number / mfg date

When filing a claim, you must provide:

DEL Ozone Warranty Department
3428 Bullock Lane, San Luis Obispo, CA 93401
Customer Service Number: (800) 676-1335 x 293
Fax Number: (805) 541-8459
E mail to service@ delozone.com

TO OBTAIN WARRANTY SERVICE:

- (a) Any labor charges for troubleshooting, removal, or installation of such parts.
- (b) Any repair or replacement of such parts necessitated by faulty installation, improper maintenance, improper operation, misuse, abuse, negligence, accident, fire, repair materials, and/or unauthorized accessories.
- (c) Any such products installed without regard to required local codes and accepted trade practices;
- (d) ANY IMPLIED WARRANTY OF MERCHANTABILITY OR IMPLIED WARRANTY OF FITNESS FOR PARTICULAR PURPOSE, AND SUCH WARRANTIES ARE HEREBY DISCLAIMED.
- (e) DEL Ozone SHALL NOT BE LIABLE UNDER ANY CIRCUMSTANCES FOR LOSS OF USE OF SUCH PRODUCTS, LOST PROFITS, DIRECT DAMAGES, INDIRECT DAMAGES, CONSEQUENTIAL DAMAGES AND/OR INCIDENTAL DAMAGES.

THIS LIMITED WARRANTY DOES NOT INCLUDE ANY OF THE FOLLOWING:

Any replaced parts must be returned to DEL OZONE for warranty evaluation.

NOTE: USE ONLY DEL Ozone AUTHORIZED REPLACEMENT PARTS. USE OF ANY OTHER PART(S) WILL AUTOMATICALLY VOID THIS WARRANTY.

The limited warranty set forth below applies to products manufactured by DEL Ozone - 3428 Bullock Lane, San Luis Obispo, California 93401, and sold by DEL Ozone or its authorized dealers. This limited warranty is given only to the first retail purchaser of such products and is not transferable to any subsequent owners or purchasers of such products.

The limited warranty set forth below applies to products manufactured by DEL Ozone - 3428 Bullock Lane, San Luis Obispo, California 93401, and sold by DEL Ozone or its authorized dealers. This limited warranty is given only to the first retail purchaser of such products and is not transferable to any subsequent owners or purchasers of such products.

