



# ECOSTEALTH

Quiet. Powerful. Protected.

**Savings  
Optimizer**

**NEW**

140,000 BTU  
MODEL



# FREE NEVER FELT SO HOT

Members only pool heat pump technology



[www.ecostealthpro.com](http://www.ecostealthpro.com)

# ADVANCED HEAT



Energy  
Optimizer



Cooling Mode  
Reversing Valve



Quiet Scroll  
Compressor Tech



# T TECHNOLOGY



Small Footprint  
Easy for Retrofits



ECO Aerodynamic  
Fan Blade Design



ECO Digital  
Controller



Weather Resistant  
Polymer Cabinet



VEXED Titanium  
Made In USA



Quick Hook-Up  
2" Union





# SAVE THE PLANET & YOUR WALLET

Save \$1000's each year for the life of your heat pump!  
Compare energy costs below, per 100,000 BTU input

 **\$0.50** 

**Natural Gas** **\$1.90**

**Propane** **\$2.50**

**Electric Resistance** **\$3.00**

## Environmentally Friendly By Design





# QUIET. POWERFUL. PROTECTED.

OPTIMIZEEP120TI    OPTIMIZEEP140HCTI    OPTIMIZEEP150TI

		VEXED Titanium	VEXED Titanium	VEXED Titanium
Heat Exchange Construction		VEXED Titanium	VEXED Titanium	VEXED Titanium
Temperature Control		Digital	Digital	Digital
Sound Level Decibels		58 dB	55 dB	55 dB
Heating and Cooling		No	Yes	No
Remote Capability		2 & 3 Wire	2 & 3 Wire	2 & 3 Wire
Performance Testing Results:				
(80°F air, 80°F water, 80% RH)	COP	5.6	5.8	5.6
	BTU/hr	112,000	132,000	140,000
**(80°F air, 80°F water, 63% RH)	COP	5.4	5.6	5.3
	BTU/hr	106,000	121,000	130,000
**(50°F air, 80°F water, 63% RH)	COP	4.0	4.0	4.0
	BTU/hr	74,000	84,000	84,000
Voltage Required		230/208V	230/208V	230/208V
Operating Current		26 Amps	29 Amps	29 Amps
Recommended Circuit Breaker		50 Amps	50 Amps	50 Amps
Maximum Circuit Breaker		60 Amps	60 Amps	60 Amps
Refrigerant		R410A	R410A	R410A
Minimum Water Flow Rate		25 GPM	25 GPM	25 GPM
Maximum Water Flow Rate		80 GPM	80 GPM	80 GPM
Dimensions	W x D x H	35" x 35" x 39"	33" x 36" x 45"	33" x 36" x 45"
Shipping Weight		315 lb	340 lb	390 lb

\*\*Ratings in accordance with ARI1160

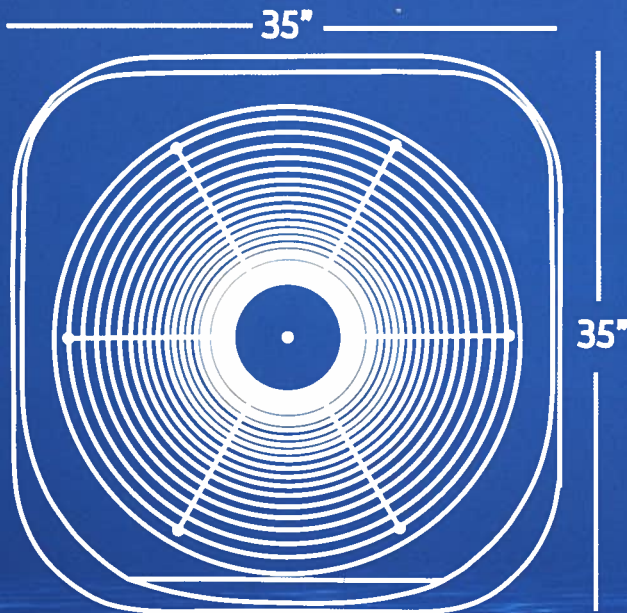

**OPTIMIZEEP120TI**

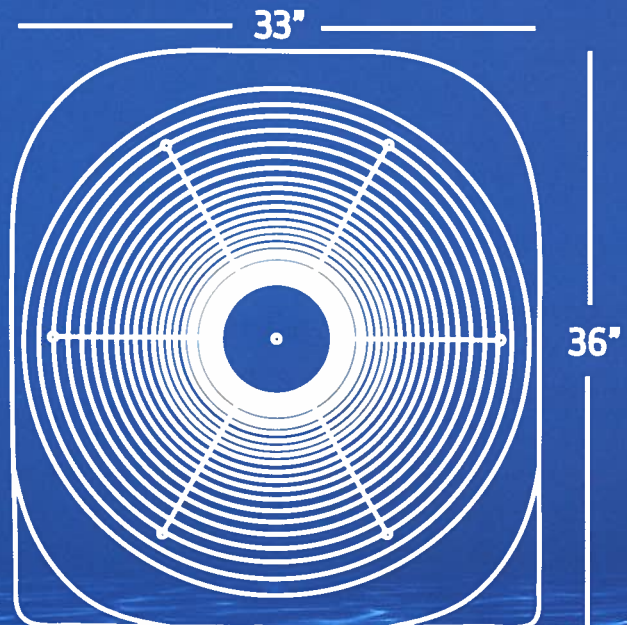

**OPTIMIZEEP140HCTI  
OPTIMIZEEP150TI**





# PEACE OF MIND!

MEMBERS  
ONLY  
WARRANTY  
OPTIONS



Manufactured and supported here in the USA. Members only hotline gives you access to human support! Register your heat pump online to take advantage of full warranty and member services available.

1-855-852-4889

[www.ecostealthpro.com](http://www.ecostealthpro.com)





# SAVE ENERGY!



## SAVINGS OPTIMIZER TECHNOLOGY

 **Savings  
Optimizer**



The Savings Optimizer Technology alerts users when hydraulic levels are created that dramatically increase the cost of operation of the pool heat pump. This alert system can save up to \$2,000 annually. At AquaPro, we're designing products to save energy every day.

### OPTIMIZER BENEFITS:

-  Save up to \$1,500 - \$2,000 annually.
-  Extend the life of your heat pump by operating in the most efficient hydraulic levels.
-  Reduce Noise





# **ECOSTEALTH ADVANTAGE**

## **Why Buy Ecostealth Heat Pumps?**

- **Featuring Copeland Scroll Compressors for ultimate quiet performance**
- **Oversized evaporator coils for maximum heat transfer**
- **Titanium heat exchanger to protect against corrosion**
- **Highly engineered total system design for ultra efficiency**
- **Only the finest components for years of dependability**

## **WARRANTY INFO**

**Extra investment protection for Ecostealth Members. Invest in superior advanced equipment and receive members only offers by registering online at:  
[www.ecostealthpro.com/register](http://www.ecostealthpro.com/register)**

**Ecostealth offers the best protection in the business. The additional protection applies to purchases and the installation of pool heat pumps.**