

# Smart Enclosure Oil Filled Heater



# General Care and Safety Guide

**YOUR SAFETY IS IMPORTANT TO US. PLEASE ENSURE YOU TAKE NOTE OF THE INSTRUCTIONS AND WARNINGS OUTLINED IN THIS MANUAL.**

**CAUTION:** In order to avoid a hazard due to inadvertent resetting of the thermal cut-out, this appliance must not be supplied through an external switching device, such as a timer, or connected to a circuit that is regularly switched on and off by the utility.

- This appliance is not intended for use by persons (including children) with reduced physical, sensory or mental capabilities or lack of experience and knowledge, unless they are supervised or have been given instruction concerning the use of the appliance by a person responsible for their safety.
- Children should be supervised to ensure that they do not play with the appliance.
- If the supply cord is damaged, it must be replaced by the manufacturer, its service agent or similarly qualified persons in order to avoid a hazard.

**WARNING:** You must not cover this appliance. Covering this appliance presents fire risk and will activate the safety fuse; permanently disabling the unit.

**WARNING:** Do not use this appliance in small rooms when they are occupied by persons not capable of leaving the room on their own, unless constant supervision is provided.

**WARNING:** To reduce the risk of fire, keep textiles, curtains, or any flammable material a minimum distance of 1 metre from the air outlet.



- Use only the voltage specified on the rating label of the appliance.
- Keep all objects at least 1 metre from the front, sides and rear of the appliance.
- The heater must not be located immediately below a socket outlet.
- This appliance is intended for household use only and not for commercial or industrial use.
- Indoor use only.
- Use this appliance only as described in this manual. Any other use is not recommended by the manufacturer and may cause fire, electric shock or injury.
- Do not use the appliance if it has been dropped or damaged.
- The common cause of overheating is deposits of dust or fluff in the appliance. Ensure these deposits are removed regularly by unplugging the appliance and vacuum cleaning the air vents and grills.

# General Care and Safety Guide

- Never use the appliance to dry clothes.
- Always unplug appliance when not in use.
- When the appliance has been unpacked, check it for transport damage and ensure all parts have been delivered. If parts are missing or the appliance has been damaged, contact the Customer Services Team.
- Do not use if there are visible signs of damage to the appliance.
- Do not connect the appliance to mains supply until completely assembled and adjusted.
- Ensure hands are dry before handling the plug or main unit.
- Ensure appliance is on a flat, stable, heat-resistant surface.
- Do not operate with cord set coiled up as a heat build up is likely, which could be sufficient to become a hazard.
- Carry out regular checks of the supply cord to ensure no damage is evident
- Do not operate this appliance with a damaged cord, plug or after the appliance malfunctions or has been dropped or damaged in any manner. Take to a qualified electrical person for examination, electrical service or repair.
- Do not twist, kink or wrap the cord around the appliance, as this may cause the insulation to weaken and split. Always ensure that all cord has been removed from any cord storage area and is unrolled before use.
- It is recommended that this appliance is plugged directly into the wall socket. Power boards are not rated to supply power to high wattage appliances.
- A correctly specified, undamaged extension cord may be used with this appliance provided it is used in a safe manner.
- Do not remove plug from power socket until the appliance has been switched off.
- Do not remove plug from power socket by pulling cord; always grip plug.
- Do not place cord under carpet or cover with rugs or furniture. Arrange the cord so it cannot be tripped over.
- Don't place appliance on bedding or on thick & long carpet where the openings may get blocked.
- Switch off and use handle provided when moving
- Do not place appliance close to radiant heat source.
- Do not insert or allow foreign objects to enter any ventilation or exhaust opening, as this may cause an electric shock, fire or damage to the appliance.
- Do not sit on the appliance.
- Do not use abrasive cleaning products on this appliance. Clean with a damp cloth (not wet) rinsed in hot soapy water only. Always remove plug from the mains supply before cleaning.
- Do not operate in areas where petrol, paint or other flammable liquids are used or stored.
- Do not use this appliance in the immediate surrounds of a bath, a shower, or a swimming pool or other liquids.

# General Care and Safety Guide

- The appliance must not be immersed in any liquids.
- There are no user serviceable parts installed in the unit.
- Do not place the unit in wardrobes or other enclosed spaces as this may cause fire hazards.
- This unit is not supposed to be used in or around locations where foodstuffs, works of art or delicate articles of science, etc. are stored.
- If your appliance does not work, or is not working properly, contact the place of purchase or the Customer Services Team.
  
- This heater is filled with a precise quantity of special oil. Repairs requiring opening of the oil container are only to be made by the manufacturer or his service agent who should be contacted if there is an oil leak

	
Model No: ACOC157	
Supply: 230-240VAC 50-60Hz	Bluetooth
Wattage: 1500W	
CLASS I	
Approval: TUV-027720-EA	
QC Passed: PO#-WWYY	
MADE IN CHINA	
<b>CUSTOMER SUPPORT</b>	
NEW ZEALAND PH: 0800 232 633	
AUSTRALIA PH: 1300 465 324	

	
Model No: ACOC2411	
Supply: 220-240VAC 50-60Hz	Bluetooth
Wattage: 2150-2400W	
CLASS I	
Approval: TUV-027720-EA	
QC Passed: PO#-WWYY	
MADE IN CHINA	
<b>CUSTOMER SUPPORT</b>	
NEW ZEALAND PH: 0800 232 633	
AUSTRALIA PH: 1300 465 324	

# Assembly

**WARNING:** Heater must not be used without the castor plates and castors fitted.

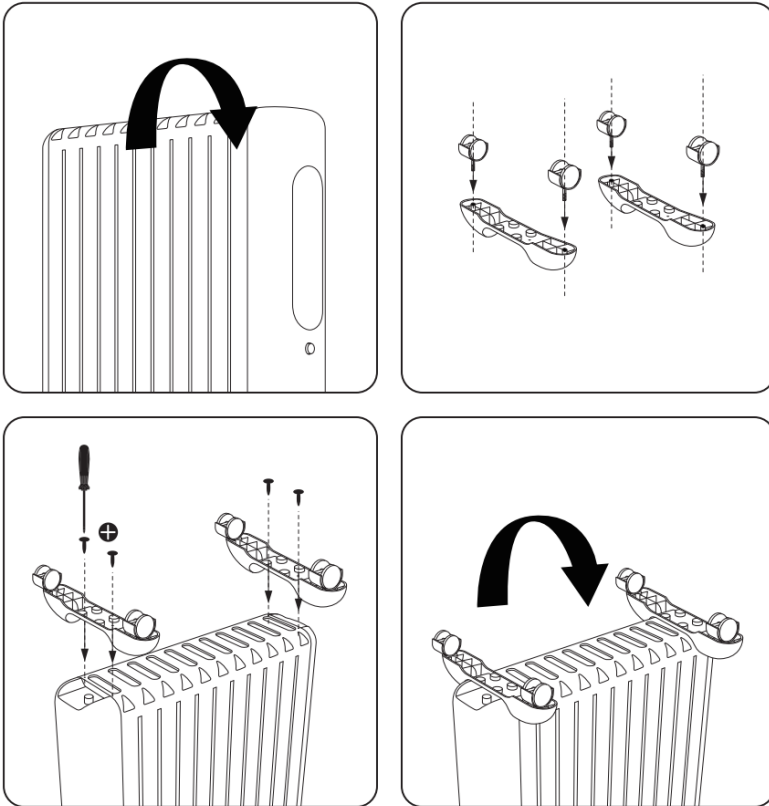

## Assembly Instruction

1. Turn the heater upside-down on a scratch-free and stable surface to prevent damage to the paint finish or your floor surfacing (see Fig 1).
2. Fit the castor wheels into the corresponding position of the foot plate.
3. Fit the wheel assemblies into the bottom of the heater using the 4 screws provided, as per Fig 2.
4. Carefully turn the heater back to the upright position and place it on a stable, level surface.

**WARNING:** Only operate the heater in normal upright position with wheels attached. If you are in any doubt about installing this product, consult a qualified electrician.

# Operating Your Oil Column Heater

Always choose a safe location for the heater, keeping in mind the safety precautions outlined. Ensure all packaging has been removed from the unit before use. Please follow the below instructions.

**WARNING:** In order to avoid overheating or fire, do not cover the heater.

**WARNING:** Keep all objects at least 1 metre from the front, sides and rear of the appliance.

**WARNING:** Do not use this heater with a programmer, separate timer, remote-control system or any other device that switches the heater on automatically, since a fire risk exists if the heater is covered or positioned incorrectly.

**WARNING:** Never leave this heater unattended when in use.









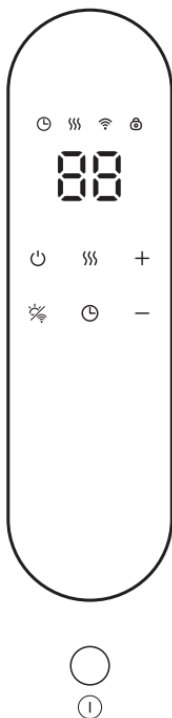



Ensure heater is on a flat, stable, heat-resistant surface.

Once the heater is in a safe operating position and all switches are in the off position, insert the power plug into the mains outlet and switch on.

**CAUTION:** Ensure the power cord is not tight because if pulled it may partially pull the plug from the socket. A partially inserted plug will overheat the plug and socket and could result in fire.

# Operating Your Oil Column Heater



	ON/OFF
	Standby button
	Heating selection Button
	Increase Button
	Decrease Button
	Timer Button
	Brightness/Wi-Fi Button
	Display
	Timer indicator
	Heating indicator
	Wi-Fi indicator
	Child lock

Check that the heat control switch is set to Off position before plugging the heater into the mains supply.

## ON/OFF BUTTON

Press the ON/OFF button located below the control panel to turn the power on and put into standby mode. The stand-by button icon will light up on the screen. Press this button again to turn the power off.

## HEATING SELECTION BUTTON

Press the heating selection button to change the heat mode. There are 3 heat settings – Low, Middle & High.

## SETTING THE TEMPERATURE

Use the '+' and '-' buttons to set your desired temperature from 5-35 degrees Celsius. After the desired temperature is set, the temperature digits will stop blinking and the set temperature will be displayed. The heating indicator icon will light up on the screen when the heater is heating. When the heater reaches the set temperature it will switch on and off automatically to maintain the set temperature.

# Operating Your Oil Column Heater

## TIMER

This heater is equipped with a 24-hour countdown timer. This enables you to preset the appliance to switch off automatically from between 1 to 24 hours in 1h increments. Press the timer button once and the screen will display 0H. Press the '+' or '-' buttons to set the timer. Once selected, the display will flash for 3 seconds. The timer indicator will light up on the screen.

## BRIGHTNESS

Press the Brightness/WiFi button to adjust the display brightness. There are 4 different levels of brightness (100%-50%-25%-0%) and each press of the button will adjust accordingly.

## CHILD LOCK

Press the '+' and '-' buttons together for 3 seconds to activate the child lock. The Child lock indicator will light up on the screen. To unlock, press the '+' and '-' buttons together for 3 seconds. The child lock indicator will disappear from the screen.

## STANDBY

Press the standby button to turn the heater off and put into standby mode.



# WiFi – Downloading and Setting up APP

**This APP is supported only on 2.4GHz Wi-Fi channels. Please ensure your phone is 2.4GHz capable**

**Note this device will only work within your home WIFI system.**

**This does not operate on 3G or 4G internet connections.**

**You will need a connection to your home Wi-Fi.**



Download Ausclimate mobile APP

- Open the APP Store or Google Play on your mobile phone.
- Open 'Search' and enter '**Ausclimate**'
- Click 'GET' and begin to download and install.

Once downloaded to your phone open the APP

- Tap REGISTER near the bottom of the screen.
- Read and agree to the Privacy Policy.
- Add your email address.
- Tap 'Obtain verification code'

You will then receive an email with a verification code.

- Enter the verification code from your email.
- Create a password.
- Then tap confirm.

If you haven't received a verification code via email, tap the resend button and when the verification code is received follow above steps.

Your APP is now registered and ready for pairing to your device.

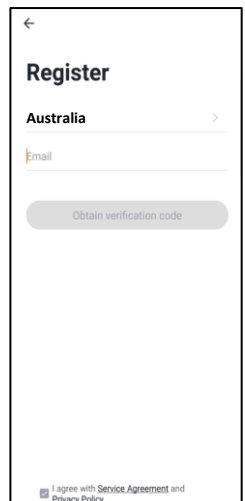
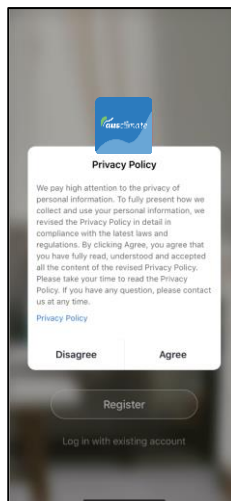
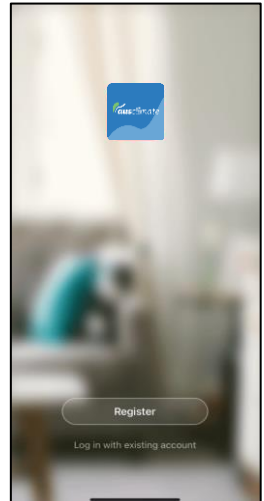

# Pairing APP to Device

Details for pairing this heater to the Ausclimate App can be found at the below website link.

Either scan the QR code below or enter the website into your browser.

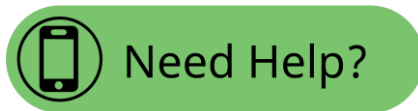

## Pairing Mode

To connect to the Ausclimate app you must ensure that your device is in pairing mode which is where the Wifi Icon is flashing.

If you want to enable WIFI mode then:

- Turn the heater on at the ON/OFF button on the front of the heater.
- Press and hold the Brightness/WiFi Button for 3 seconds. The WiFi indicator icon will light up on the control panel, and will flash rapidly.

## Quick Connection

- Turn your phone's Bluetooth ON
- Ensure your device is in Pairing Mode (see instructions above)
- Tap the + on the top right corner to navigate to the main device screen. Tap 'Auto Scan' – your device will appear. Tap the device and follow the instructions.
- If Quick Connection does not work, follow the manual via the QR Code above

# Operating Your Heater

## SAFETY DEVICES

This appliance has three protection devices:

- Tilt Switch - this will automatically turn the appliance off if the appliance is not in the correct operating position.
- Resettable Thermal Link - this will automatically disconnect the power to the appliance at a pre-set overheat temperature. After cooling down it will reset and power on again. If this occurs, investigate what is causing the appliance to overheat.

**CAUTION:** The appliance generates heat during use. Precautions must be taken to prevent the risk of burns, scalds, fires or other damage to persons.

## CARE AND CLEANING

The heater requires regular cleaning to ensure trouble free operation:

- Unplug the heater from the mains supply before cleaning.
- Ensure that the heater has been allowed to cool down completely before cleaning.
- The common cause of overheating is deposits of dust or fluff in the appliance. Ensure these deposits are removed regularly by unplugging the appliance and vacuum cleaning the air vents and grills.
- Use a damp cloth (not wet) to wipe the exterior of the heater to remove dust and dirt.
- Never use solutions such as petrol, thinners or polishing agents.
- Ensure the heater is dry before plugging back into the mains supply.

This appliance cannot be serviced. Do not attempt to dismantle.

There are no user serviceable parts. For service or repair, contact an authorised electrical service technician.

When disposing of the appliance, follow the local council regulations concerning disposal of oil.

## PROOF OF PURCHASE

To receive warranty retain receipt as proof of purchase. (Refer to back of booklet).



### SUPPORT AND TECHNICAL ADVICE

**Ausclimate – New Zealand**  
Monday – Friday 8am-5pm  
Phone +64 (0)9 917 4000  
Phone 0800 232 633

**Ausclimate – Australia**  
Monday – Friday 8am-5pm  
Phone 1800 122 100

# Troubleshooting



**SCAN HERE  
FOR HELP**

**[www.ausclimate.com.au](http://www.ausclimate.com.au)  
[www.ausclimate.co.nz](http://www.ausclimate.co.nz)**



## Two Year Warranty

Thank you for purchasing this Ausclimate product. Your product is warranted against faults and manufacture when used in normal domestic use for a period of **two years**. In non-domestic use Ausclimate limits the voluntary warranty to **three months**.

Ausclimate present consumers with the option of extending their warranty by a **further two years** to a total warranty period of **four years**, if the unit is registered on the Ausclimate website.

Ausclimate undertake to repair or replace this product at no charge if found to be defective due to a manufacturing fault during the warranty period.

This warranty excludes damage caused by misuse, neglect, shipping accident, incorrect installation, or work carried out by anyone other than a qualified electrical service technician.

PLEASE KEEP YOUR RECEIPT AS THIS WILL HELP VERIFY YOUR WARRANTY.

The benefits given to you by this warranty are in addition to other rights and remedies available to you under law in relation to the goods or services to which this warranty relates.

In Australia, our goods come with guarantees that cannot be excluded under the Australian Consumer Law. You are entitled to a replacement or refund for a major failure and compensation for any other reasonably foreseeable loss or damage. You are also entitled to have the goods repaired or replaced if the goods fail to be of acceptable quality and the failure does not amount to a major failure.

In New Zealand this warranty is additional to the conditions and guarantees of the Consumers Guarantee Act (1993).

### Ausclimate – New Zealand

CDB Media Ltd.  
PO Box 100-707  
N.S.M.C  
Auckland

Phone 0800 232 633  
www.ausclimate.co.nz

### Ausclimate – Australia

CDB Goldair Australia Pty  
PO Box 574  
South Morang  
Victoria, 3752

Phone 1800 122 100  
www.ausclimate.com.au

### Ausclimate Two Year Warranty (IMPORTANT: Please complete and retain this warranty card)

Name

---

---

Address

---

---

---

---

Place Of Purchase

---

Date Of Purchase

---

Name Of Product

---

Model Number

---

Attach a copy of the purchase receipt to this warranty card





healthy indoor climate solutions

CDB  GROUP

Australia  
PO Box 574,  
South Morang,  
Victoria, 3752  
[www.ausclimate.com.au](http://www.ausclimate.com.au)

New Zealand  
PO Box 100707,  
North Shore Mail Centre,  
Auckland, 0745  
[www.ausclimate.co.nz](http://www.ausclimate.co.nz)