

CRUZI™

Instruction Manual



THE PERSONAL URBAN CART

www.gocruzi.com

What's Included

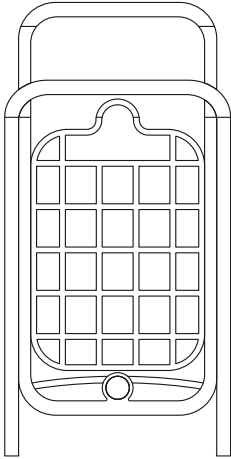

CRUZI Frame

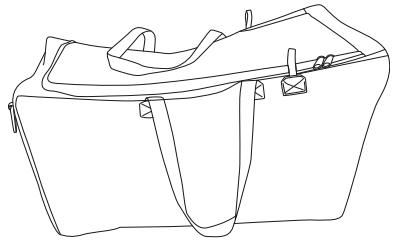

Canvas Tote Bag

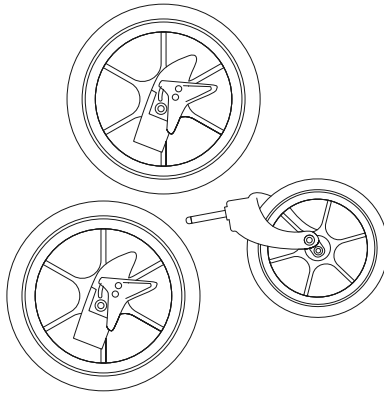

3 Wheels

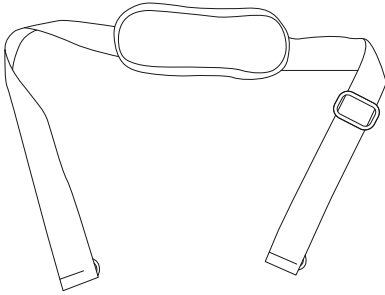

Shoulder Strap

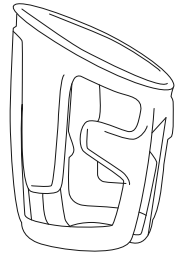

Cup Holder

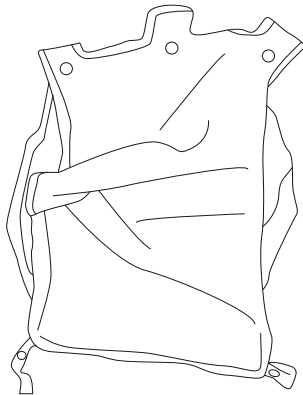

Bottom Storage

ASSEMBLY GUIDE

1

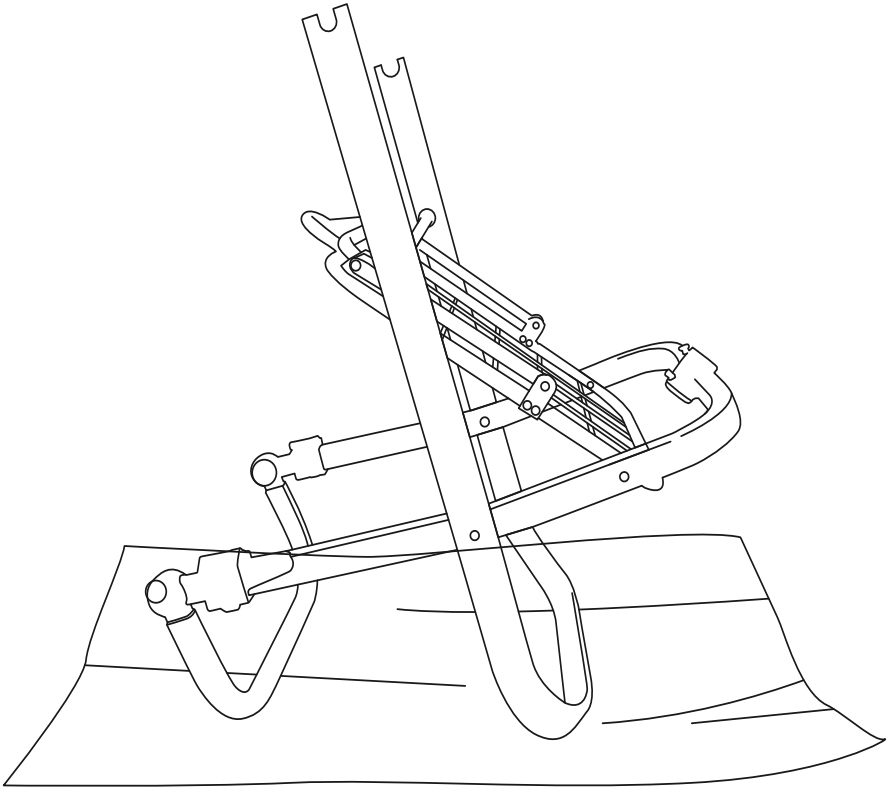

- Turn the frame upside down
- Avoid the coated surface touching ground by putting a soft layer protection in between to prevent scratches to the coated.

2

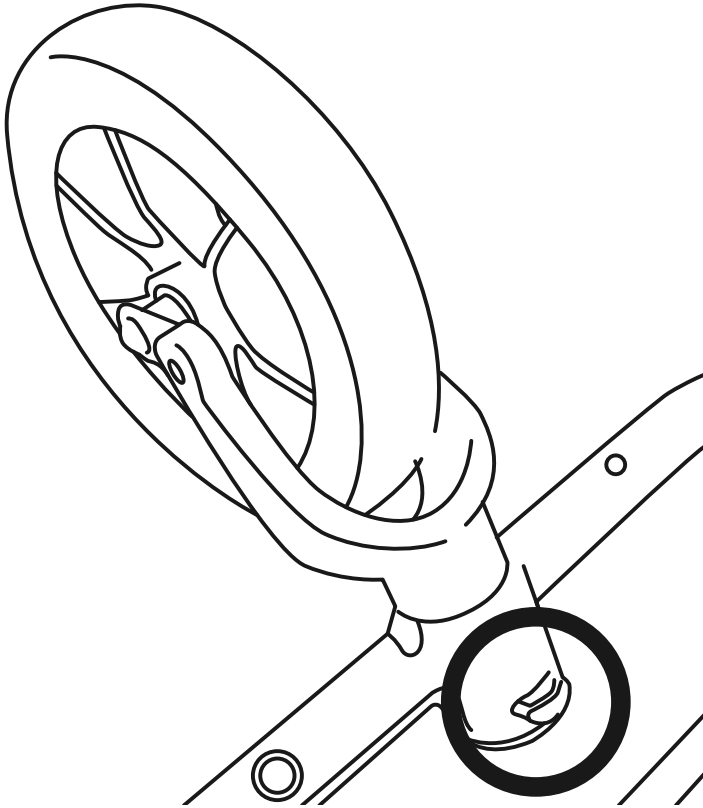

- Clip wheel into sleeve
- The button should bounce up after wheel has been installed

3

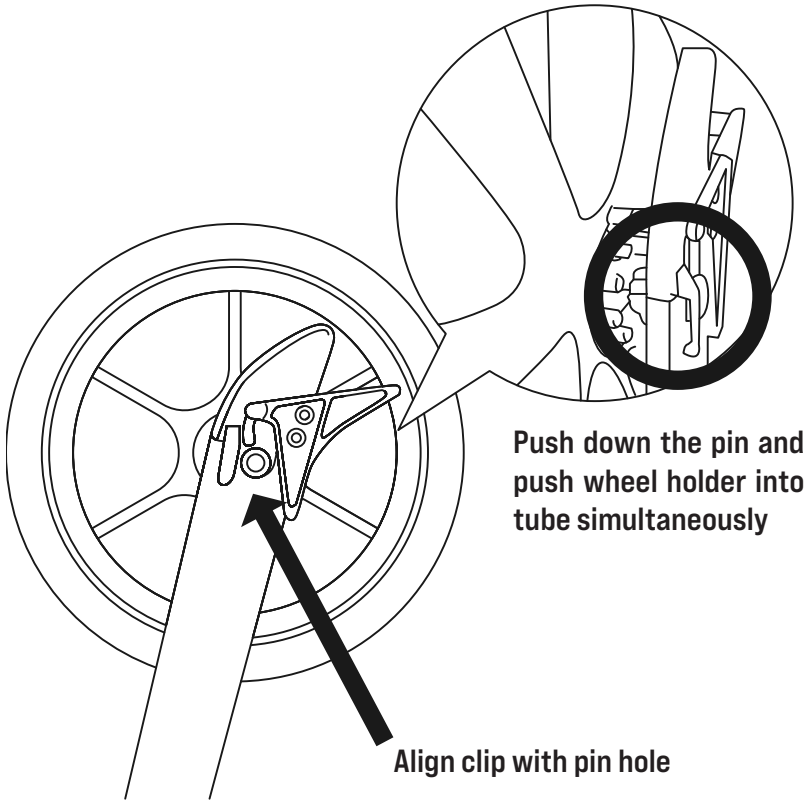

- Clip wheel into sleeve
- The button should bounce up after wheel has been installed

4

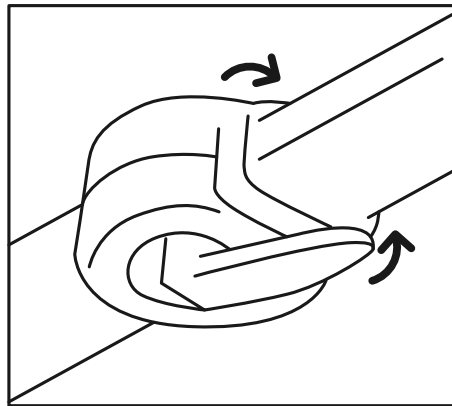
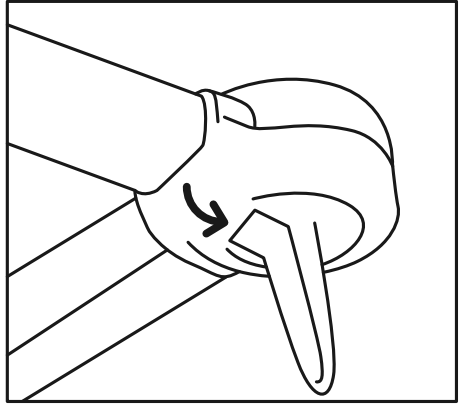
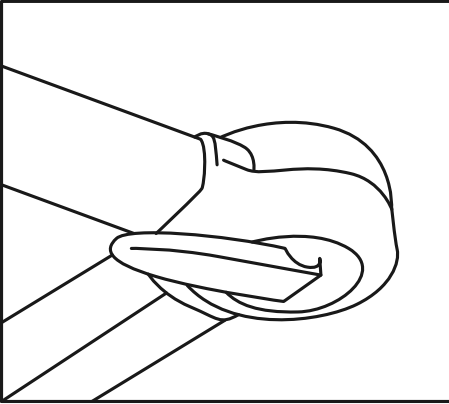

HELPFUL TIP

- To adjust the handle, first unclip the lock
- Rotate the bar to desired position
- Lock the clip in place

5

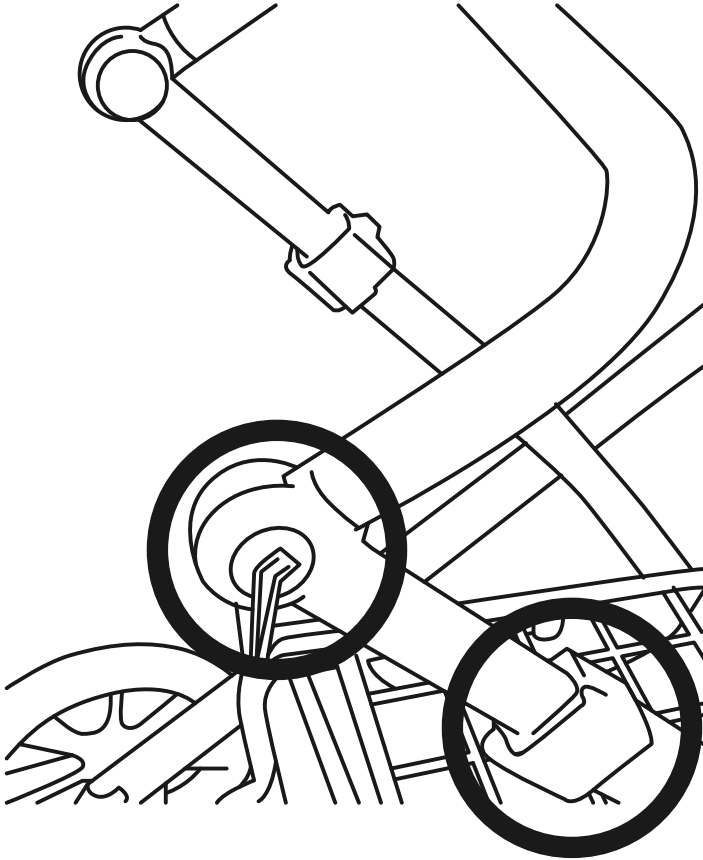

- Adjust handle to desired height
- Open side closure to adjust frame length

6

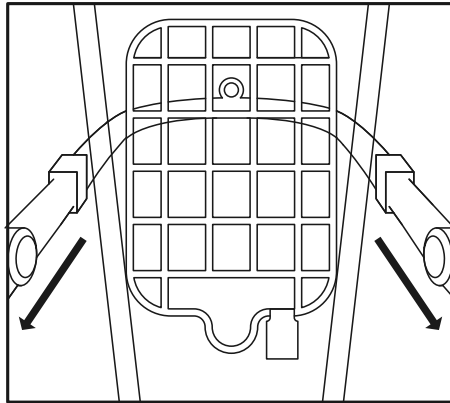
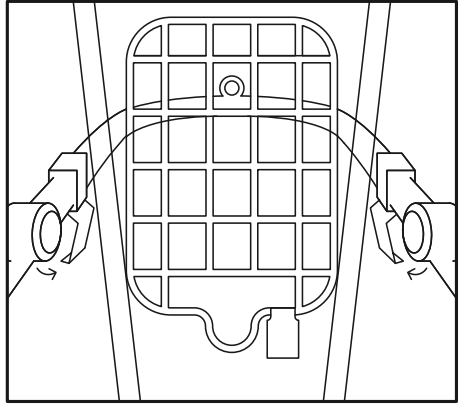
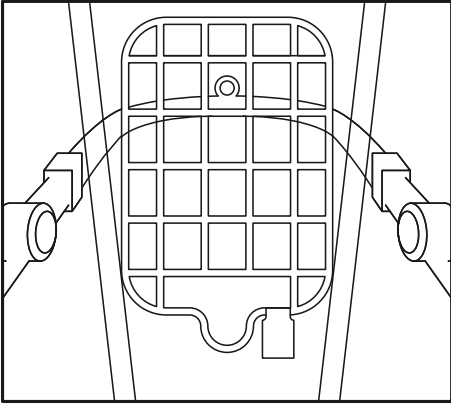

HELPFUL TIP

- Place the frame facing upwards
- Unclip the side lock to extend the handle
- Adjust to desired length

7

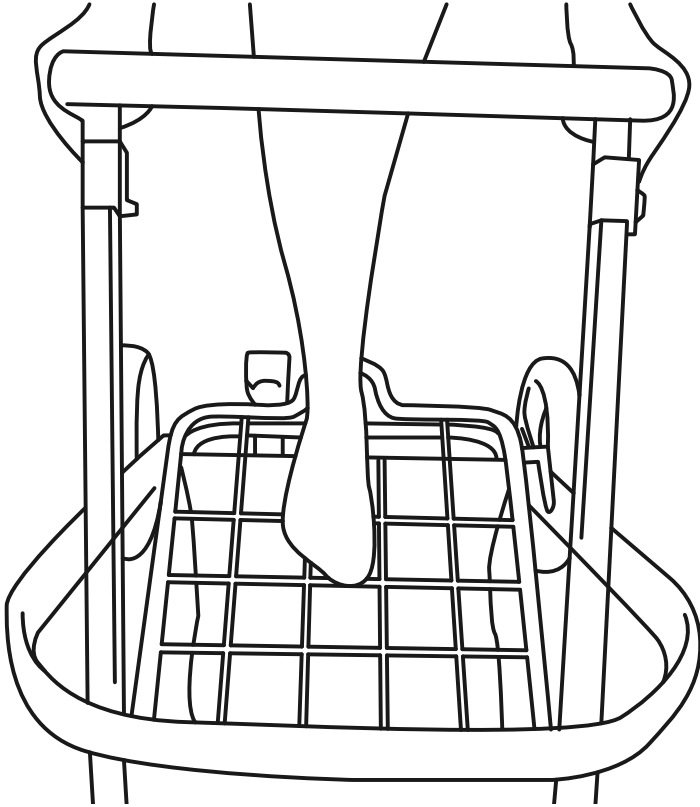

HELPFUL TIP

- Place foot on grid while pulling up

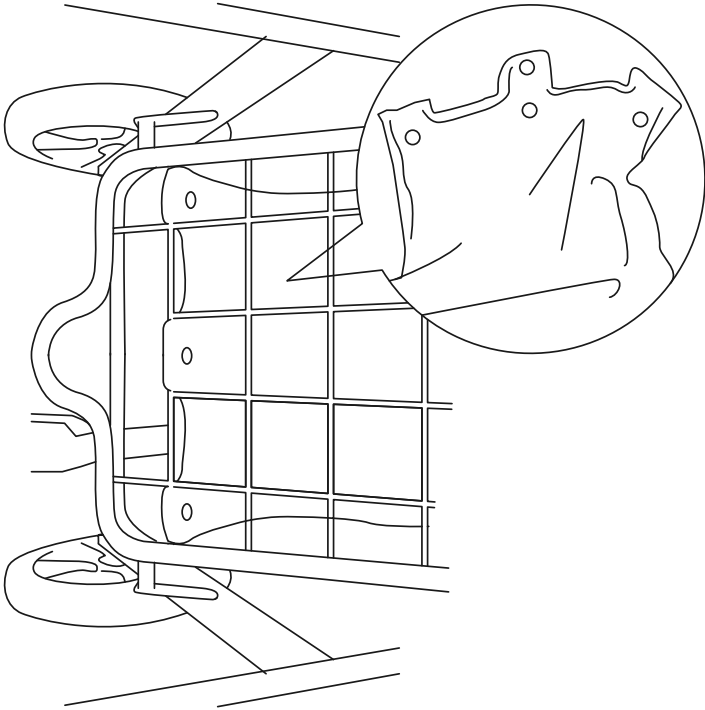

- Clip the three snaps to the back inside grid
- Clip the two snaps to the front inside grid

9

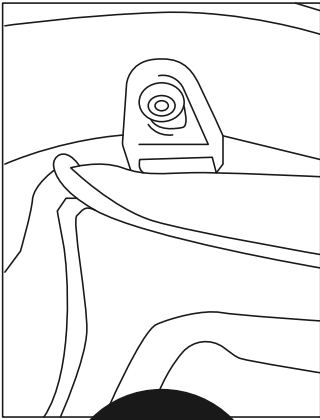

FRONT

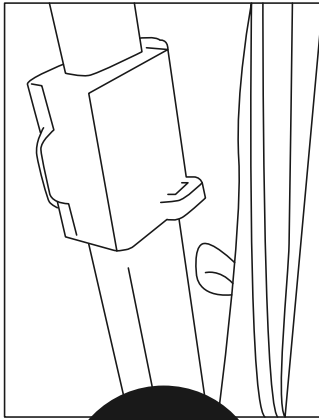

BACK

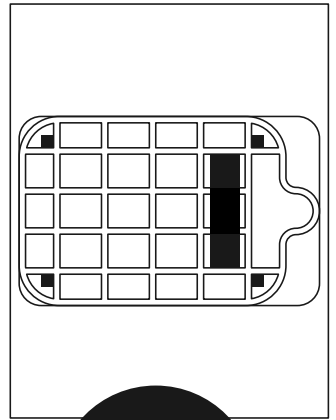

BOTTOM

- Front hook snaps into place
- Back loop slips over clip
- Fix the bag to grid by velcro under the bag

FOLDING GUIDE

1

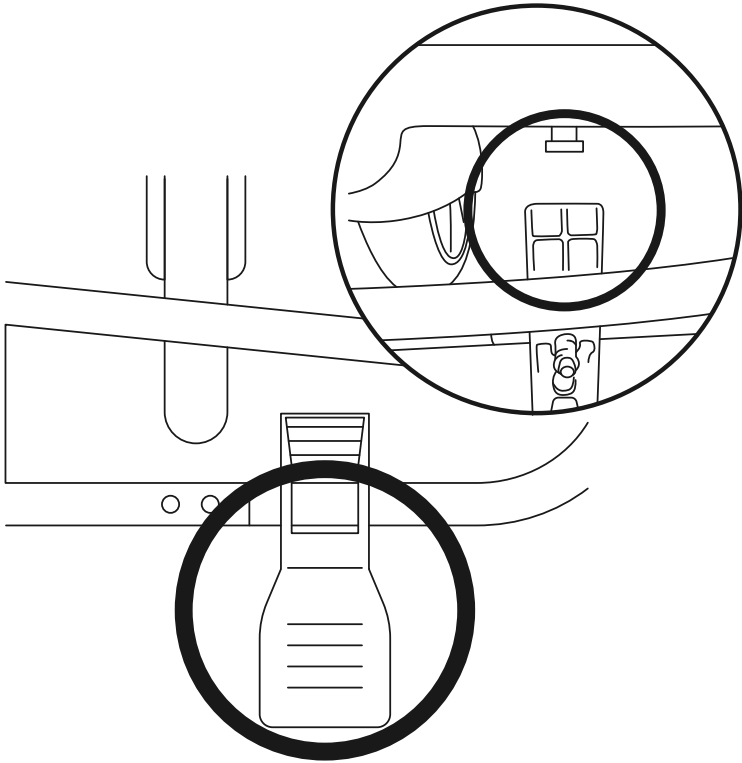

- Push the pedal to release the pin
- Pedal release closure pin

2

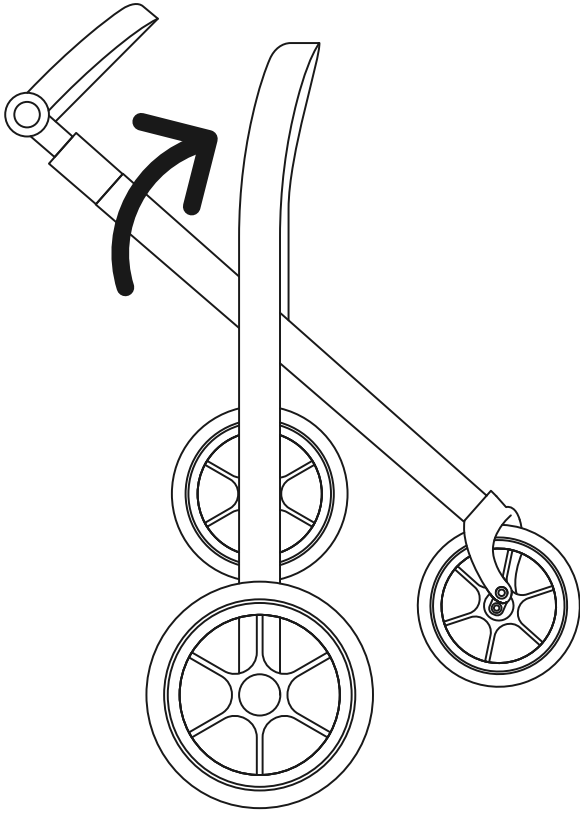

- Push forward on front of blue frame to open.

3

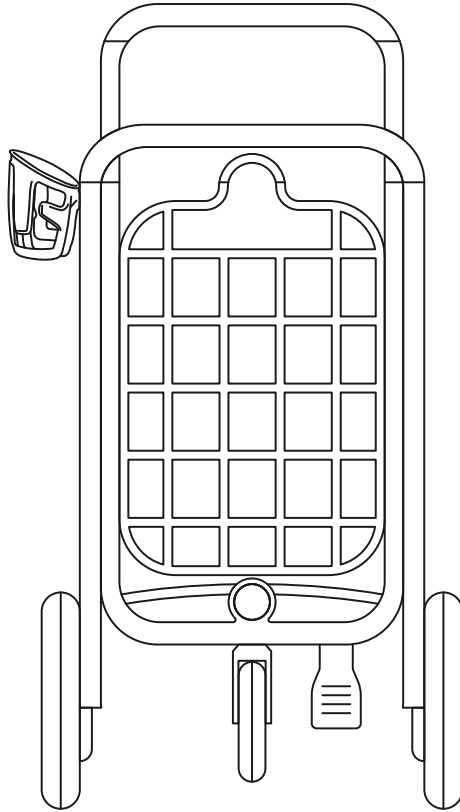

- To close collapse frame until you hear a click and pin has securely latched

PRECAUTIONS

Before using the cart:

1. The pin on the grid is securely engaged with the hole on the foot pedal.
2. The hand bar rotation locker and handle bar sliding locker is locked
3. The brakes on both rear wheels are released.

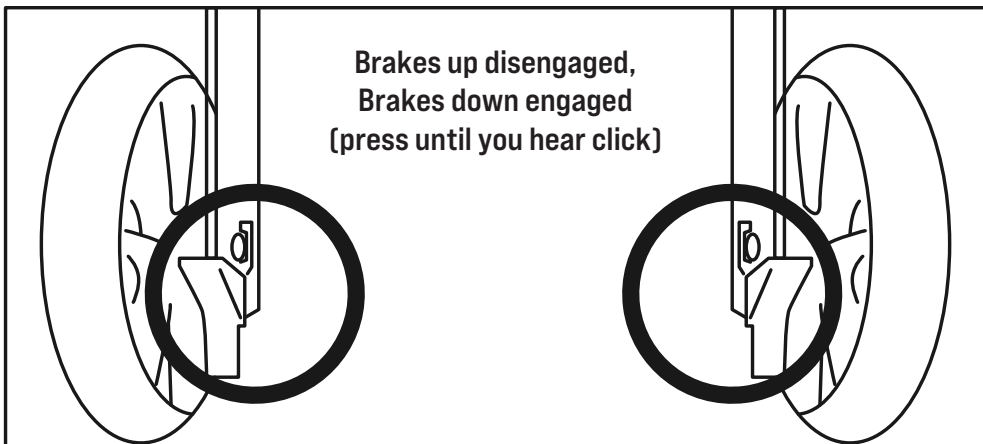
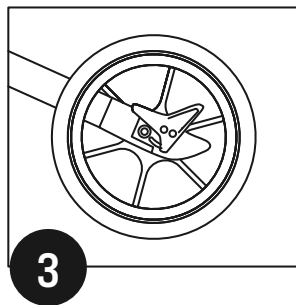
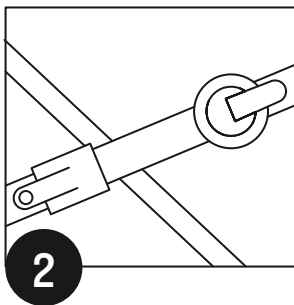
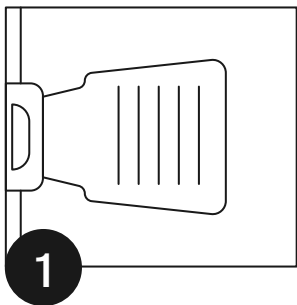

4. Don't exceed the load Limits: Big Bag: MAX 25KG ALONE | MAX 45KG ON CART Bottom Storage: MAX 3KG

5. Balance: Try to distribute the weight of things loaded to the cart as evenly as you can, so that it always stays stable when you move the cart.

6. Always use both hands to push the cart when moving.

7. Always park the cart on flat ground and use two brakes on the rear wheels stop the cart from unintentional movement

8. Don't use the cart to take baby or pet anytime.

CRUZI™

www.gocruzi.com