

# LEITNER

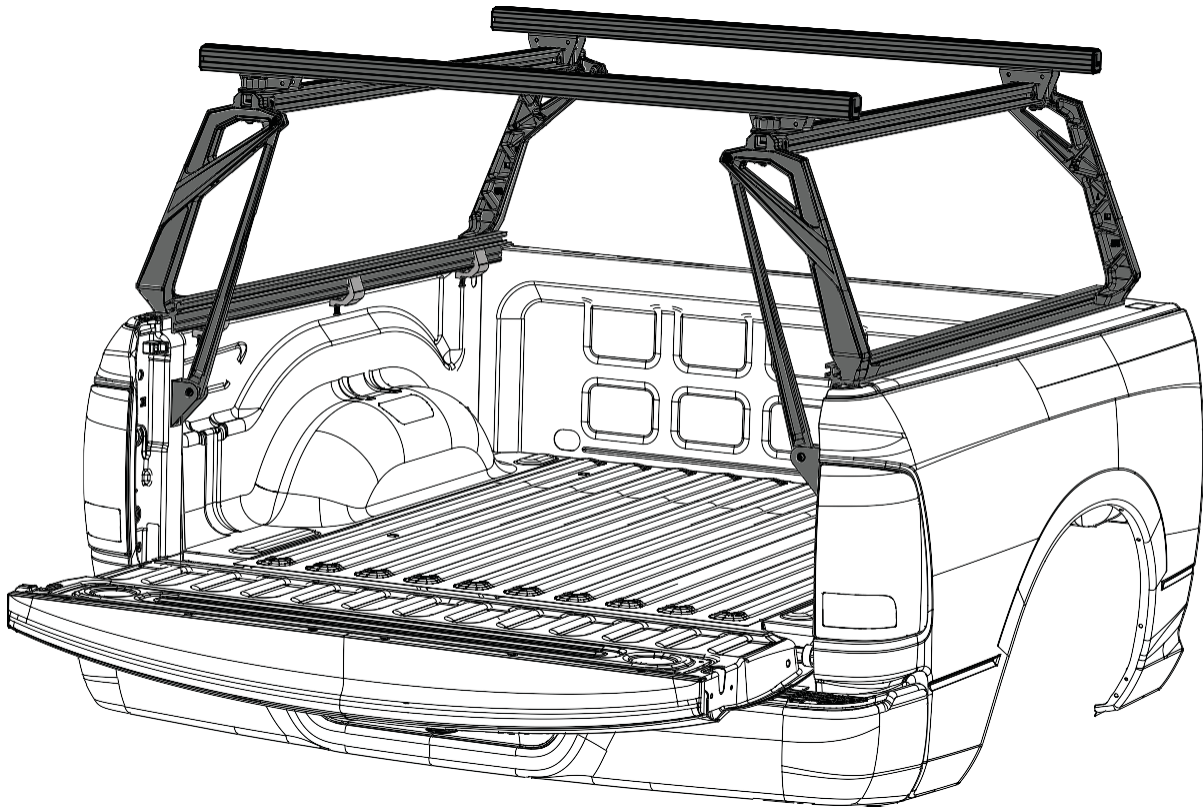

**FULL SIZE / MIDSIZE**

LEITNERDESIGNS.COM | SALES@LEITNERDESIGNS.COM | 949-395-3049

# ASSEMBLY / INSTALLATION INSTRUCTIONS:

## ACTIVE CARGO SYSTEM PART NUMBERS:

00-58-FA-1315 (5-0' BED LENGTH)

00-64-FA-1309 (5-1/2' BED LENGTH)

00-71-FA-1341 (6-0' BED LENGTH)

00-74-FA-1343 (6'-4" BED LENGTH)

00-78-FA-1345 (6-1/2' BED LENGTH)

## TOOLS REQUIRED

- TORQUE WRENCH
- T30 TORX BIT SOCKET
- T40 TORX BIT SOCKET
- 5MM HEX BIT SOCKET
- 10MM WRENCH
- 13MM WRENCH
- ELECTRIC DRILL
- TAPE MEASURE
- CENTER PUNCH

## TOOLS INCLUDED

- 25/64 DRILL
- RIVET NUT SET TOOL
- T30 TORX BIT SOCKET
- T40 TORX BIT SOCKET

## INSTALLATION TIME

**2-3 HOURS**

BASIC KNOWLEDGE OF HAND TOOLS REQUIRED

## SKILL LEVEL



3= INTERMEDIATE



INSTALLATION VIDEO

LEITNERDESIGNS.COM | SALES@LEITNERDESIGNS.COM | 949-395-3049

# ▼ READ BEFORE INSTALLING ACTIVE CARGO SYSTEM



**1. THERE ARE 2 DIFFERENT UPRIGHTS CLEARLY MARKED A & B. THE A BRACKET IS USED ON THE PASSENGER SIDE BY THE CAB AND ON THE DRIVERS SIDE BY THE TAILGATE. THE B UPRIGHT IS USED BY THE DRIVERS SIDE CAB AND PASSENGERS SIDE TAILGATE. KEEP THIS IN MIND WHEN ASSEMBLING**

2. DON'T OVER-TIGHTEN BOLTS. ALL 10MM BOLTS = (40LB-FT) ALL 8MM BOLTS = (14FT-LB) ALL 6MM BOLTS = 8FT-LB) RAIL CLAMP BOLTS (7FT-LB)
3. **NOTE: DROP IN PLASTIC BED LINERS WILL NEED TO BE REMOVED BEFORE INSTALLING ACTIVE CARGO SYSTEM.**
4. LAY DOWN A LARGE AREA OF CARPET OR BLANKETS AS A WORK AREA TO AVOID SCRATCHING PARTS DURING ASSEMBLY.
5. TWO EXTRA RIVET NUTS ARE INCLUDED IN CASE YOU MAKE A MISTAKE DURING ASSEMBLY.
6. TAKE YOUR TIME TO DO IT RIGHT, MEASURE TWICE, DRILL ONCE.
7. ALTHOUGH THE ACTIVE CARGO SYSTEM IS LIGHT HAVING A FRIEND TO HELP IS RECOMMENDED.

## ▼ ASSEMBLY OVERVIEW ▼

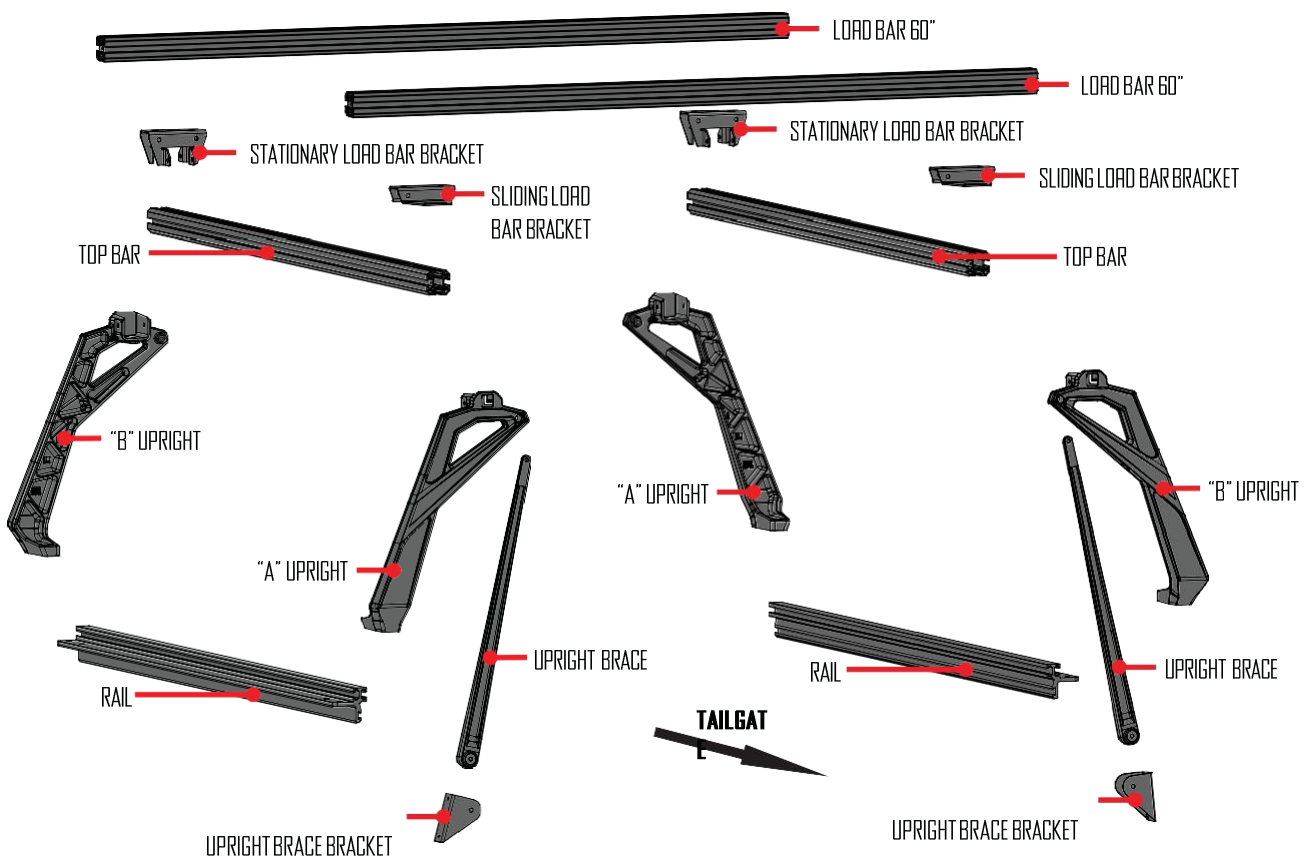

LEITNERDESIGNS.COM | SALES@LEITNERDESIGNS.COM | 949-395-3049

# ▼ ACTIVE CARGO SYSTEM HARDWARE ▼

LONG T-NUT  
(X8)



SHORT T-NUT  
(X4)



SINGLE T-NUT  
(X4)

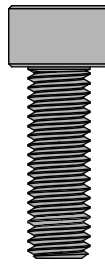
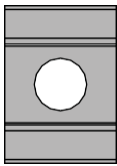

M8 X 25  
(X2)

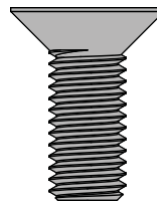

M10 X 25  
(X8)

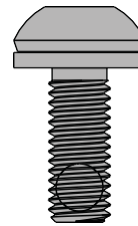

M8 X 20  
(X16)

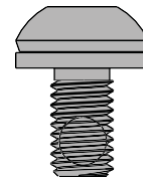

M8 X 14  
(X16)

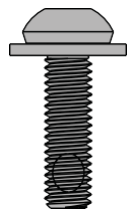

M6 X 20  
(X4)

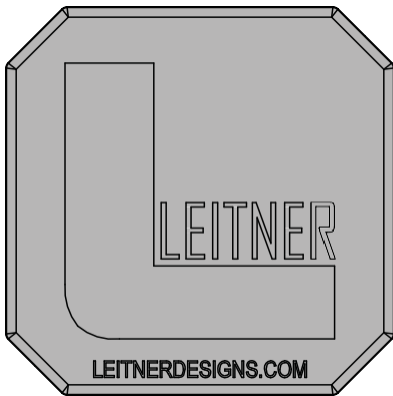

ENDCAP  
(X4)

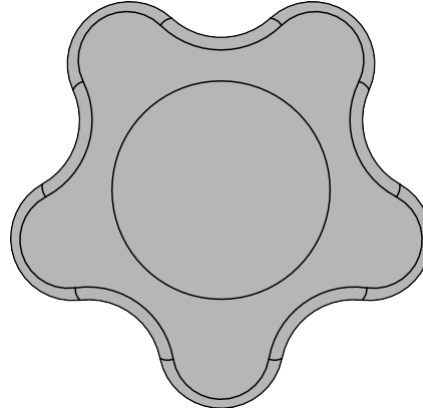

KNOB  
(X4)

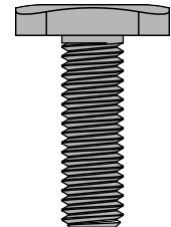

M8 T-BOLT  
(X4)

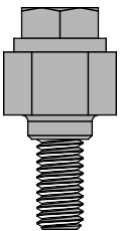

RIVET NUT SET TOOL  
(X1)

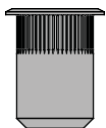

RIVET NUT  
(X6)

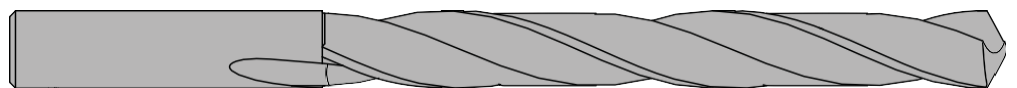

25/64 DRILL  
(X1)

# ▼ ACTIVE CARGO SYSTEM RAIL CLAMP HARDWARE ▼



M8 X 60  
(X6)

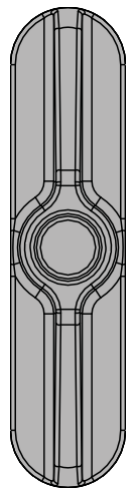

RAIL CLAMP SPACER  
(X6)

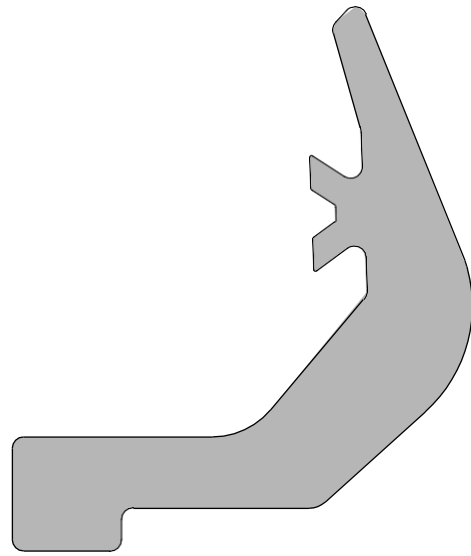

RAIL CLAMP  
(X6)

# PREP: STATIONARY LOAD BAR BRACKET

- INSTALL 2 M8 X 14 BOLTS THROUGH BRACKET AND THREAD INTO LONG T-NUT. DO NOT TIGHTEN AT THIS TIME.
- REPEAT STEPS BELOW FOR SECOND BRACKET.
- SET ASIDE FOR USE IN A LATER STEP.

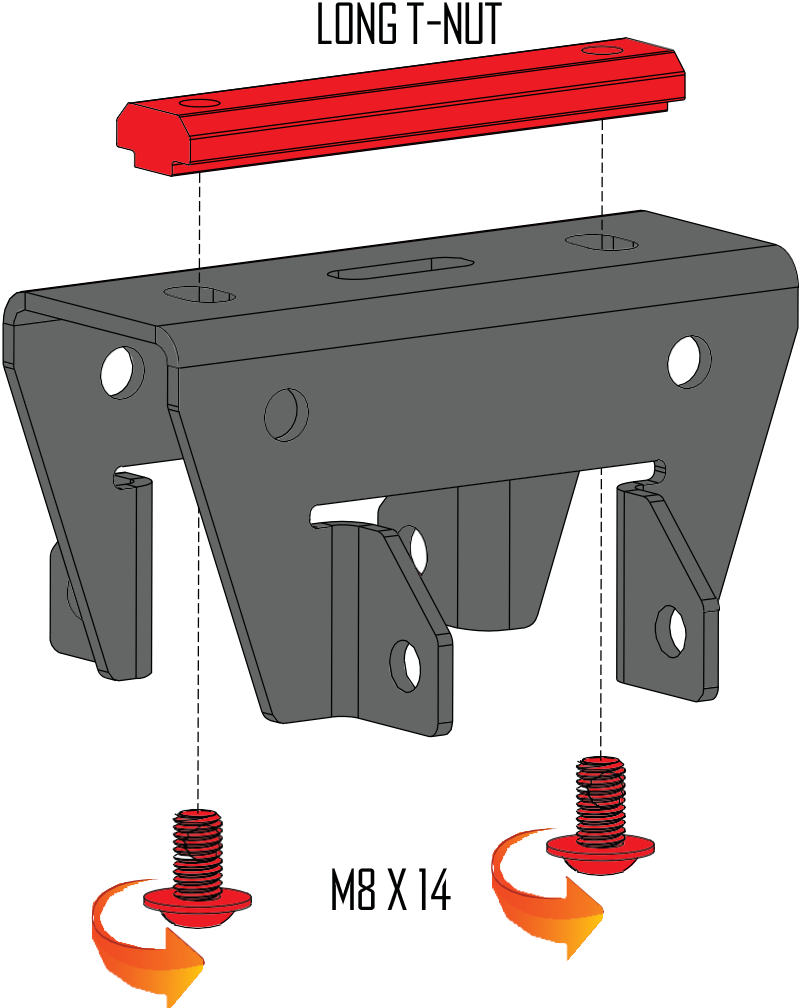

# PREP: SLIDING LOAD BAR BRACKETS

- INSTALL 2 M8 X 14 BOLTS THROUGH BRACKET AND THREAD INTO LONG T-NUT. DO NOT TIGHTEN AT THIS TIME.
- REPEAT STEPS BELOW FOR SECOND BRACKET.
- SET ASIDE FOR USE IN A LATER STEP.

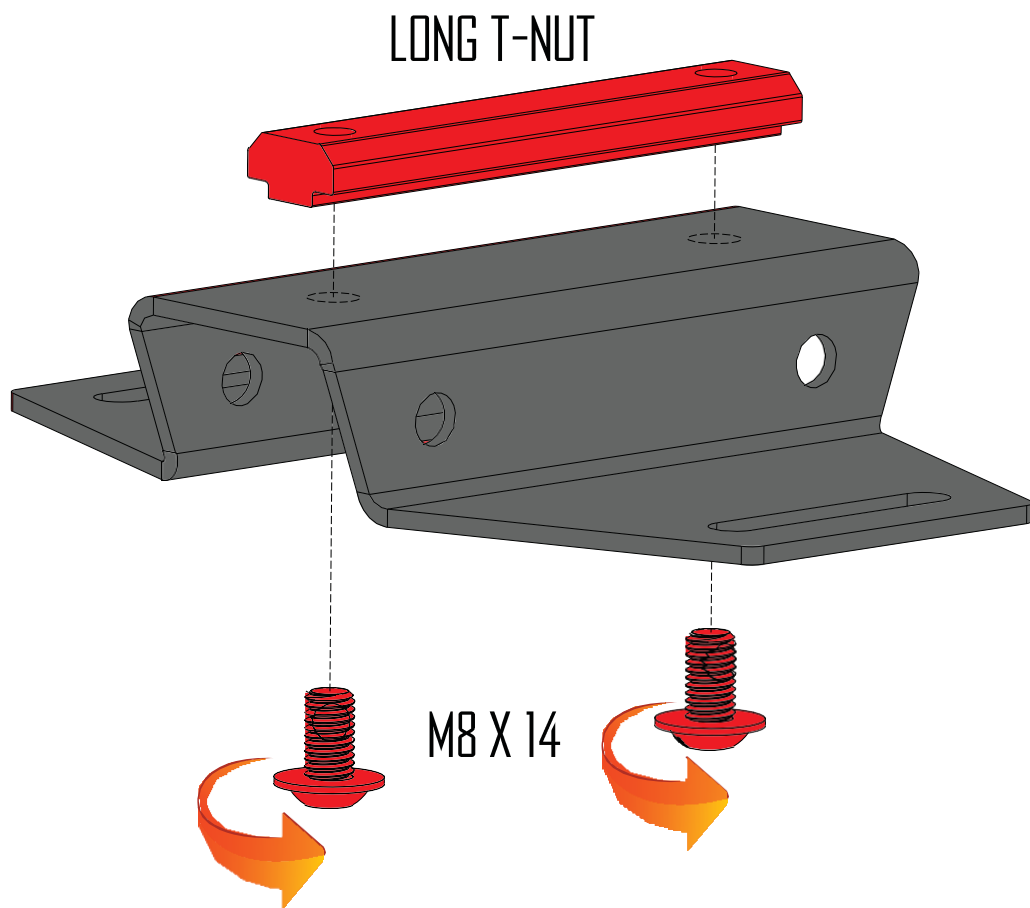

# PREP: RAIL CLAMPS

- INSTALL A M8 X 60 BOLT INTO EACH OF THE 6 RAIL CLAMPS AS SHOWN.
- THREAD THE BOLT IN SO THAT 1/4" TO 1/2" PROTRUDES OUT THE TOP OF THE CLAMP.
- SET ASIDE FOR USE IN A LATER STEP.
- NOTE: THIS STEP IS NECESSARY SO THAT THE CLAMP BOLTS WILL FIT UNDER THE TRUCK BED LIP DURING INSTALL.

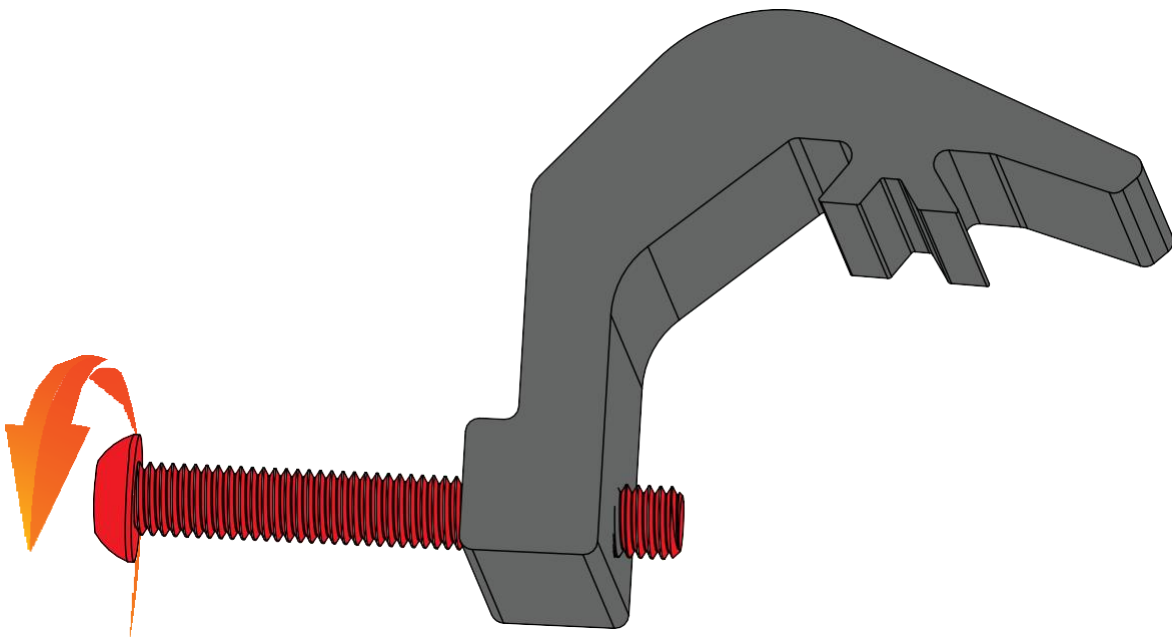



# ASSEMBLE DRIVER SIDE: OVERVIEW

- IN THE NEXT FEW STEPS YOU WILL ASSEMBLE THE DRIVERS SIDE PROTION OF THE ACTIVE CARGO SYSTEM.
- THE ILLUSTRATION BELLOW SHOWS WHAT THE PART WILL LOOK LIKE WHEN FULLY ASSEMBLED. YOU CAN REFER BACK TO THIS ILLUSTRATION AT ANY TIME TO CLARIFY PART LOCATION.

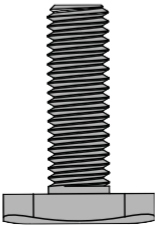
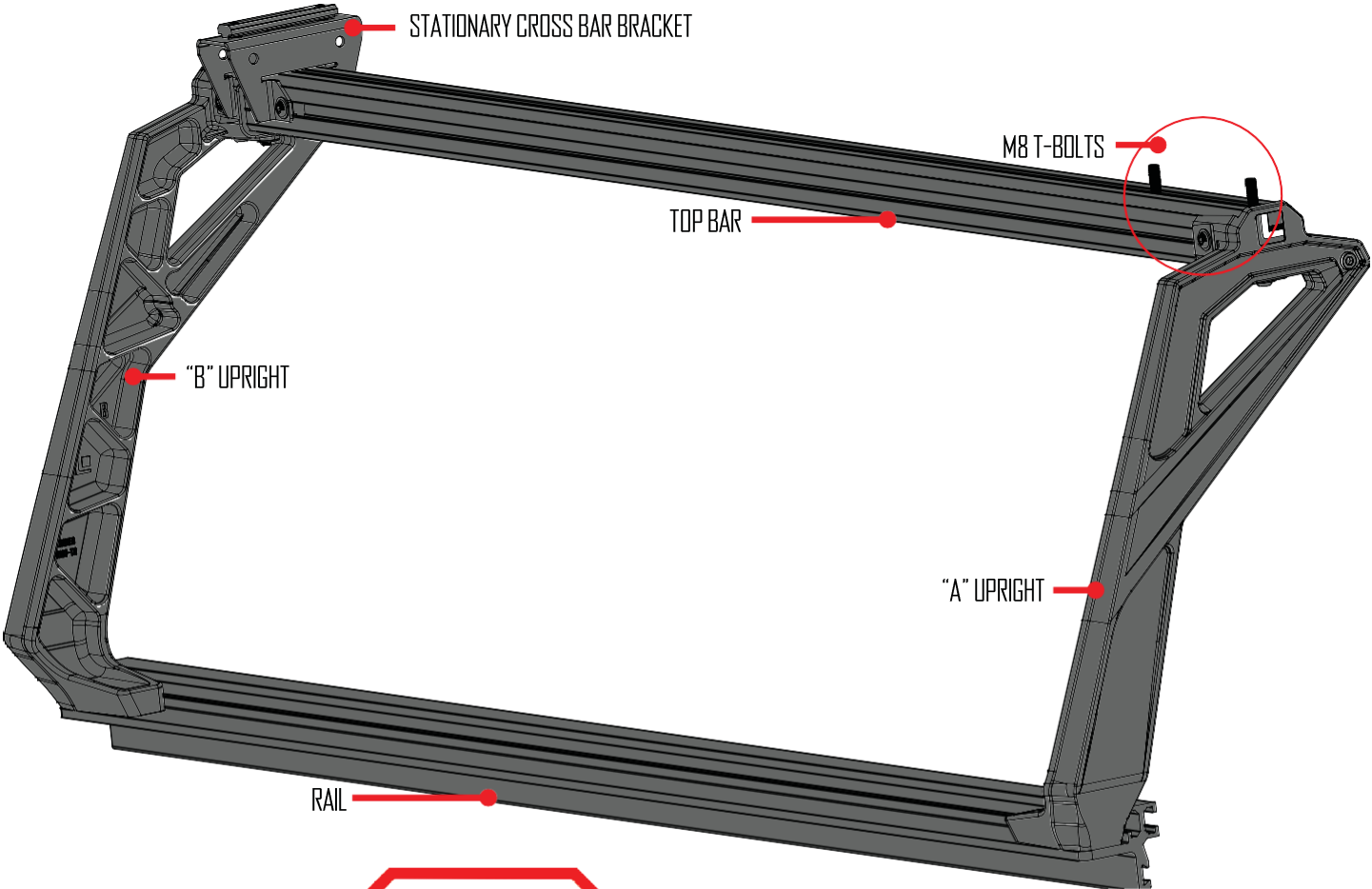

M8 T-BOLT

**TWO (2) M8 T-BOLTS NEED TO BE SLIDE INTO THE UPPER MOST T-TRACK BEFORE ASSEMBLING THE UPRIGHTS. IF YOU FORGET THIS STEP YOU WILL NOT BE ABLE TO INSTALL THE SLIDING LOAD BAR BRACKETS ON PAGE 25!! WE WILL REMIND YOU TO DO THIS AGAIN SO DONT MESS THIS UP!!**

# ASSEMBLE DRIVER SIDE: UPRIGHT "A"

- ASSEMBLE UPRIGHT MARKED "A" AS SHOWN IN THE FOLLOWING DIAGRAM.
- THREAD TWO M8 X 20 BOLTS INTO THE SHORT T-NUT. DO NOT TIGHTEN AT THIS TIME.
- THREAD ONE M8 X 14 BOLTS INTO EACH ONE OF THE SINGLE T-NUTS. DO NOT TIGHTEN AT THIS TIME.
- SET ASIDE FOR USE IN A LATER STEP.

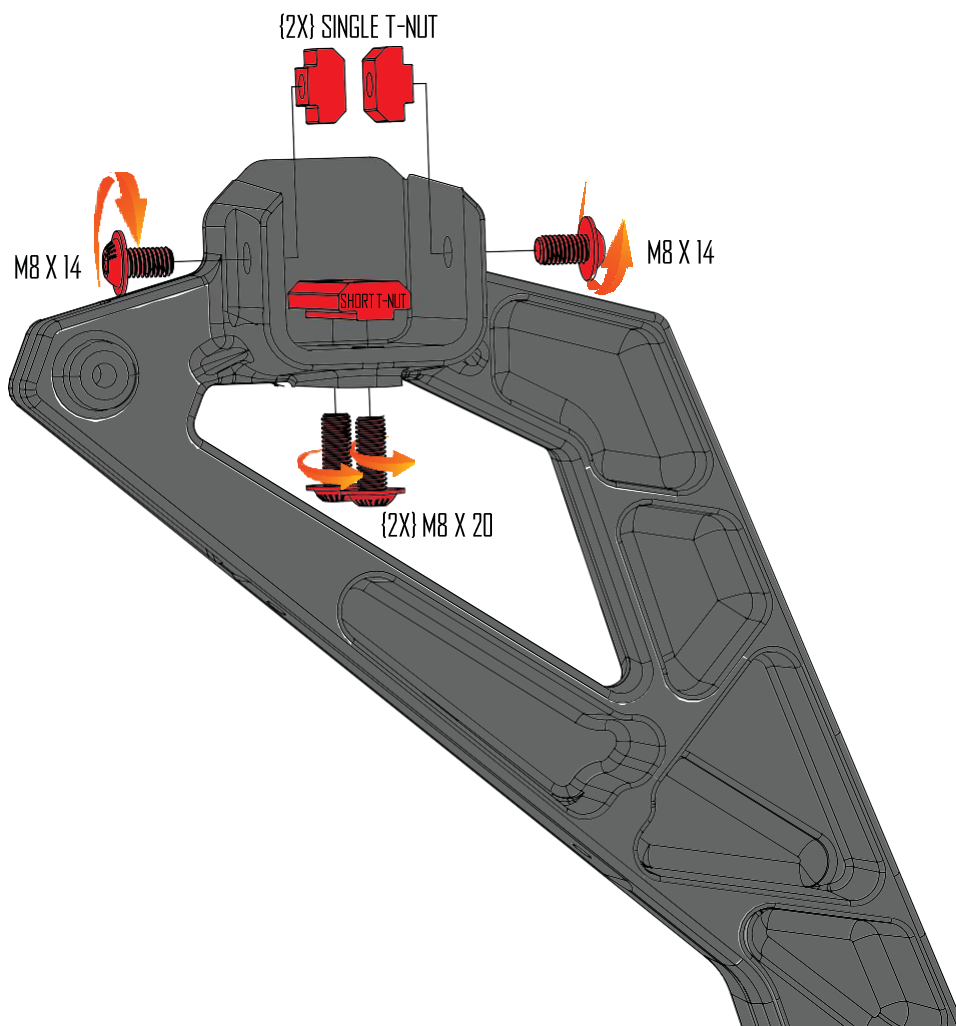

# ASSEMBLE DRIVER SIDE: UPRIGHT "B"

- ASSEMBLE UPRIGHT MARKED "B" AS SHOWN IN THE FOLLOWING DIAGRAM.
- THREAD TWO M8 X 20 BOLTS INTO THE SHORT T-NUT. (FIG-A) DO NOT TIGHTEN AT THIS TIME.
- THREAD TWO M8X 20 BOLTS THROUGH CROSS BAR BRACKET AND UPRIGHT INTO LONG T-NUT (FIG-B) DO NOT TIGHTEN AT THIS TIME.
- THREAD TWO M8X 14 BOLTS THROUGH CROSS BAR BRACKET INTO LONG T-NUT (FIG-B) DO NOT TIGHTEN AT THIS TIME.

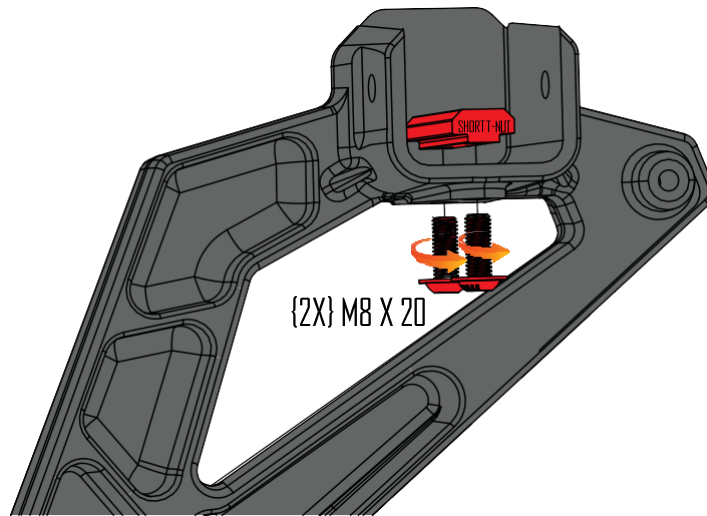

**FIG-A**

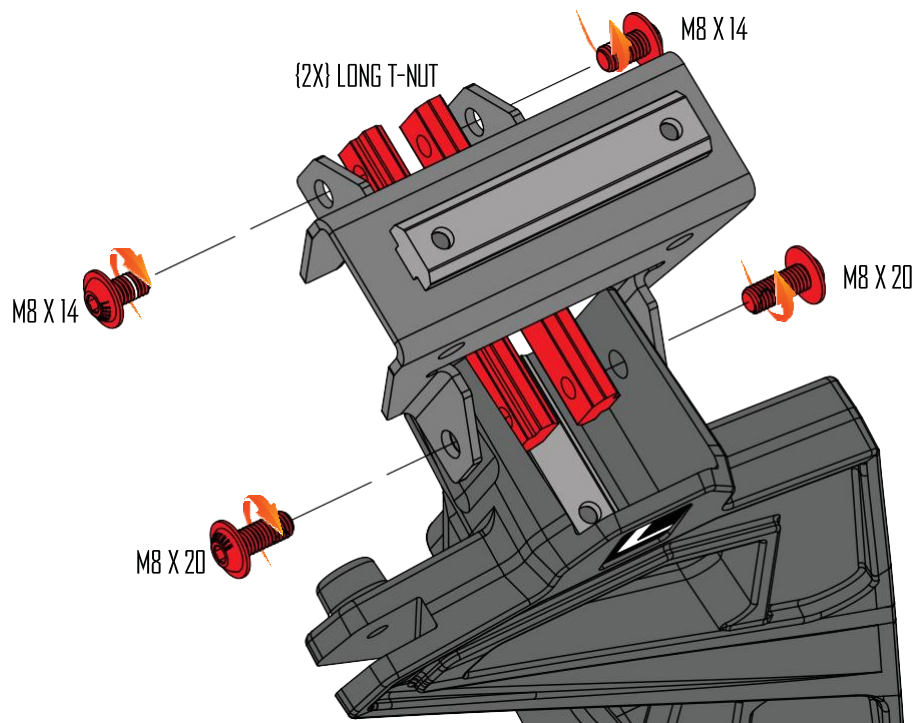
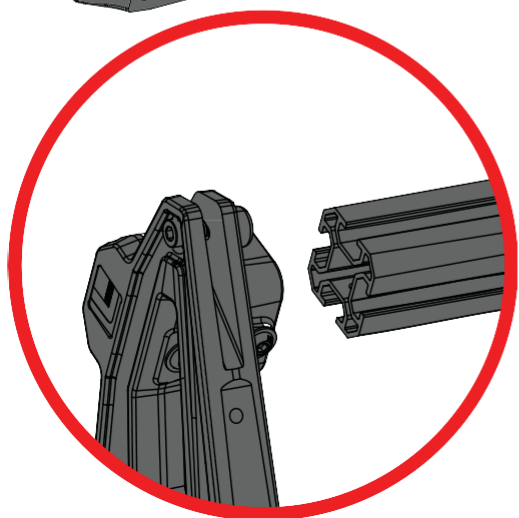
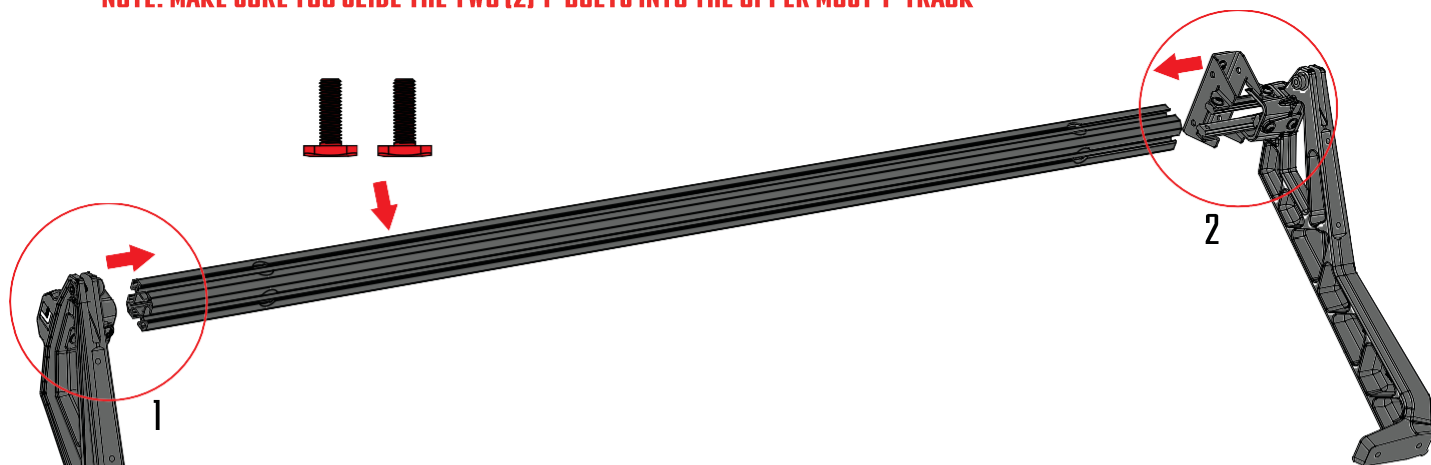

**FIG-B**

# ASSEMBLE DRIVER SIDE: TOP BAR

· ATTACH A & B UPRIGHT ASSEMBLYS TO TOP BAR AS SHOWN IN ILLUSTRATION BELOW. DO NOT TIGHTEN BOLTS AT THIS TIME.

· **NOTE: MAKE SURE YOU SLIDE THE TWO (2) T-BOLTS INTO THE UPPER MOST T-TRACK**



**DETAIL-1**

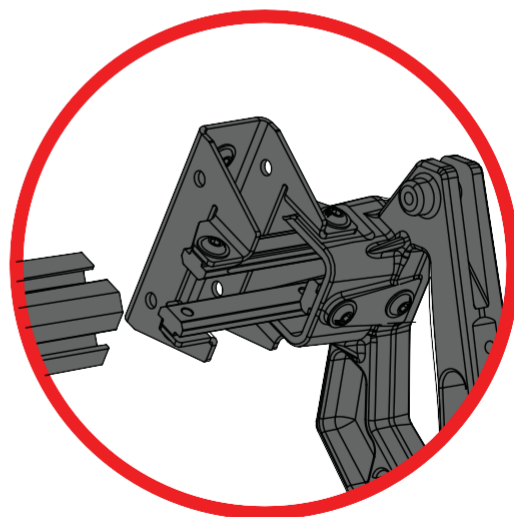

**DETAIL-2**

# ASSEMBLE DRIVER SIDE: RAIL

- ATTACH RAIL TO UPRIGHTS USING FOUR M10 X 25 SCREWS. TORQUE TO 40 FT-LB USING A T40 TORX WRENCH.
- TORQUE ALL M8 BOLTS INSTALLED IN PREVIOUS STEP TO 14 FT-LB USING A T40 TORX WRENCH.
- **IMPORTANT: TIGHTEN M10X22 BOLTS FIRST THEN TORQUE THE M8 BOLTS.**

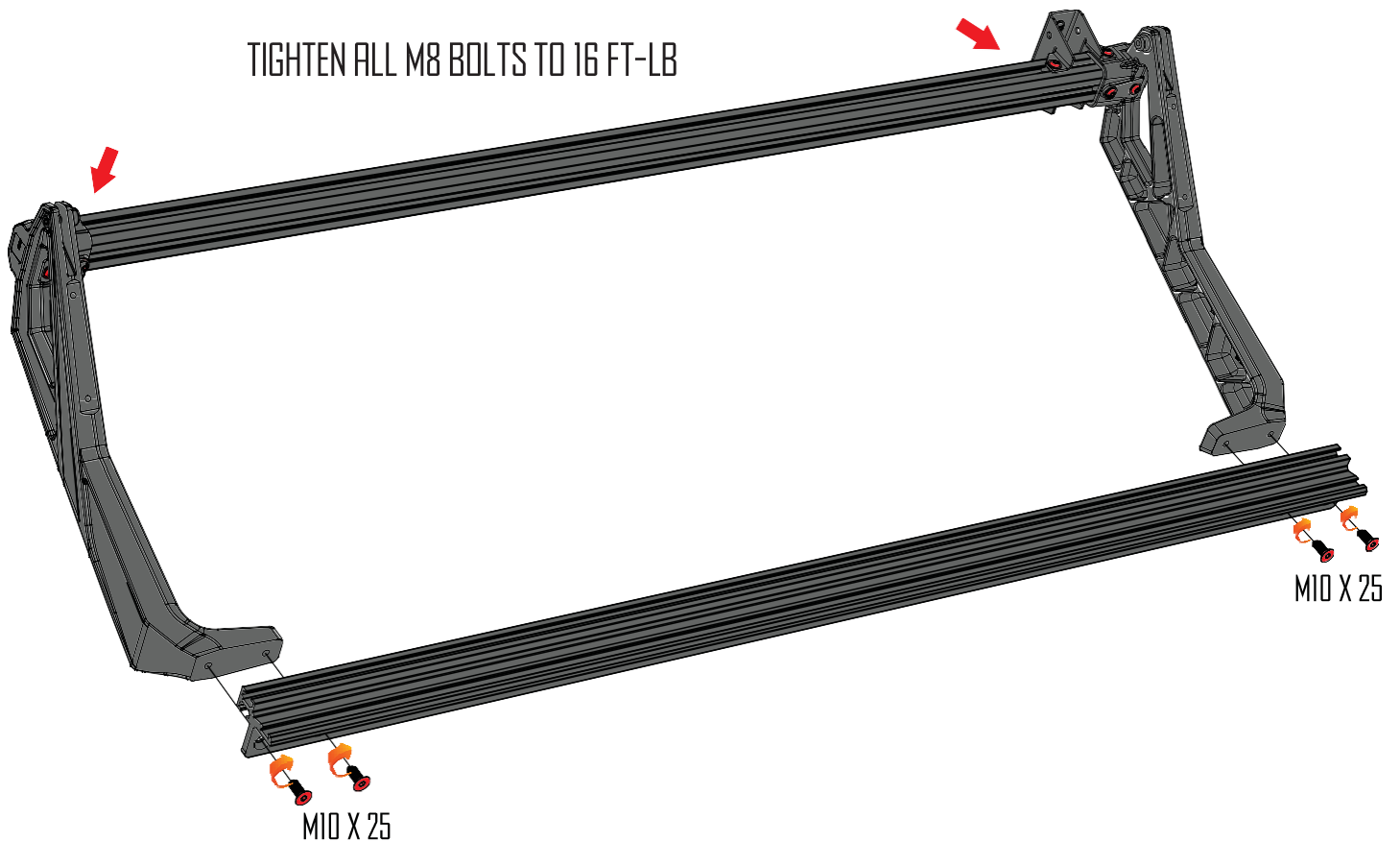

# ASSEMBLE PASSENGER SIDE: OVERVIEW

- IN THE NEXT FEW STEPS YOU WILL ASSEMBLE THE PASSENGER SIDE PORTION OF THE ACTIVE CARGO SYSTEM.
- THE ILLUSTRATION BELOW SHOWS WHAT THE PART WILL LOOK LIKE WHEN FULLY ASSEMBLED. YOU CAN REFER BACK TO THIS ILLUSTRATION AT ANY TIME TO CLARIFY PART LOCATION.

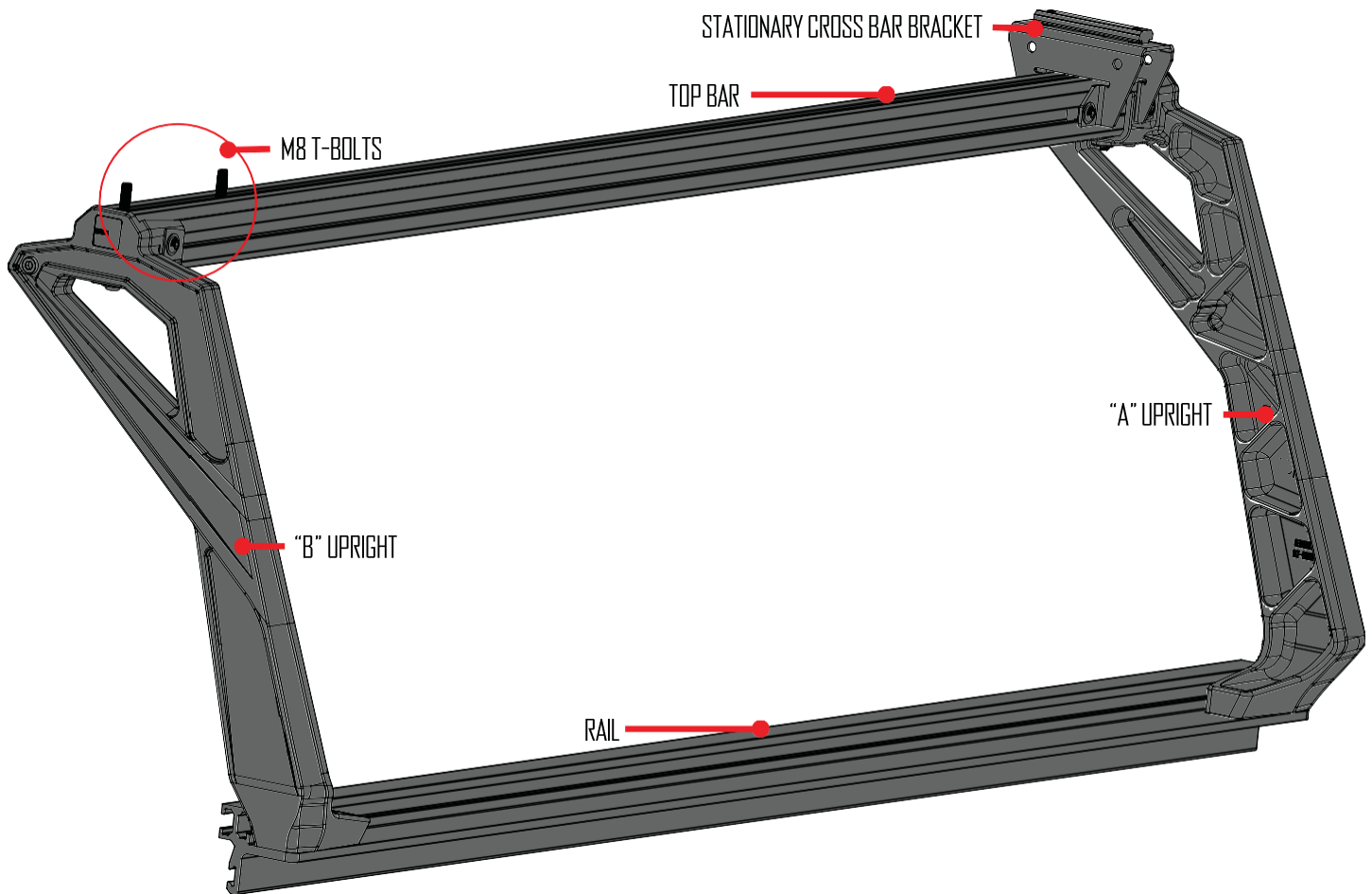

**THE TWO (2) M8 T-BOLTS NEED TO BE SLID INTO THE UPPER MOST T-TRACK BEFORE ASSEMBLING THE UPRIGHTS. IF YOU FORGET THIS STEP YOU WILL NOT BE ABLE TO INSTALL THE SLIDING LOAD BAR BRACKETS ON PAGE 25!! WE WILL REMIND YOU TO DO THIS AGAIN SO DONT MESS THIS UP.**

# ASSEMBLE PASSENGER SIDE: UPRIGHT "B"

- ASSEMBLE UPRIGHT MARKED "B" AS SHOWN IN THE FOLLOWING DIAGRAM.
- THREAD TWO M8 X 20 BOLTS INTO THE SHORT T-NUT. DO NOT TIGHTEN AT THIS TIME.
- THREAD ONE M8 X 14 BOLTS INTO EACH ONE OF THE SINGLE T-NUTS. DO NOT TIGHTEN AT THIS TIME.
- SET ASIDE FOR USE IN A LATER STEP.

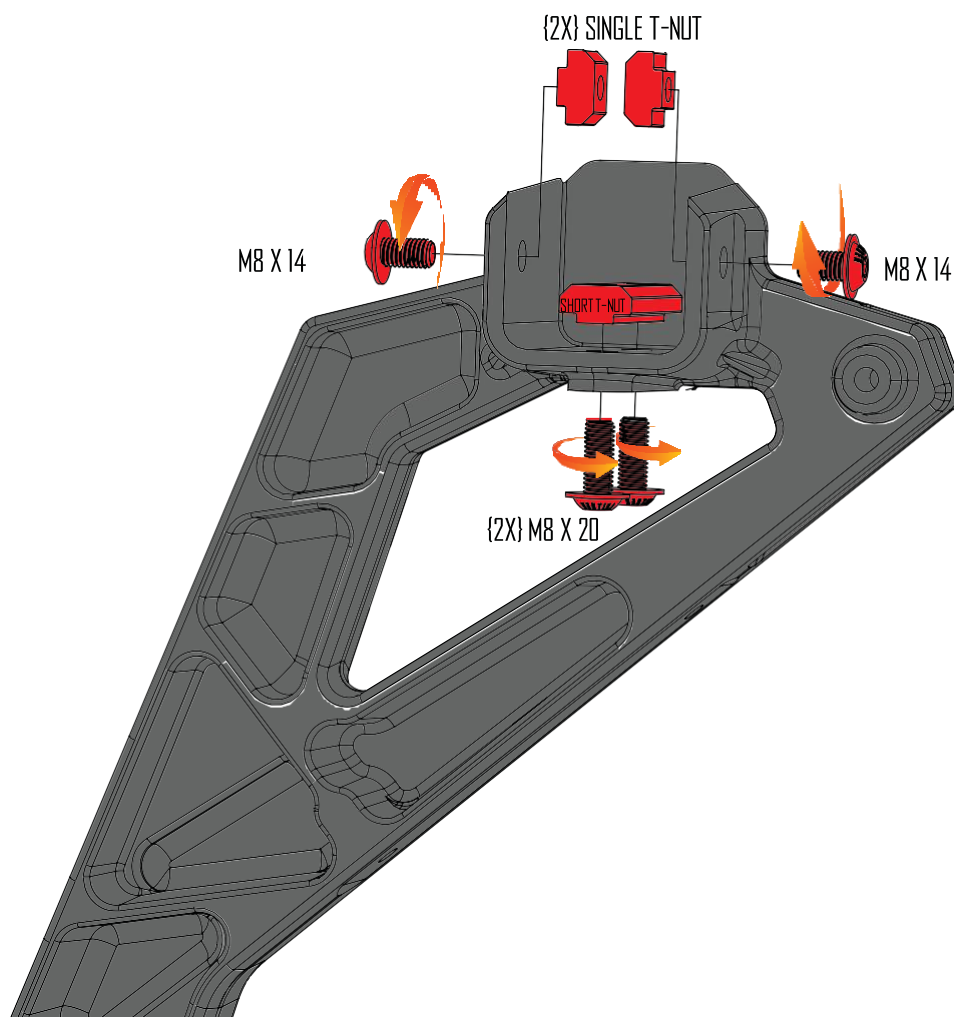

# ASSEMBLE PASSENGER SIDE: UPRIGHT "A"

- ASSEMBLE UPRIGHT MARKED "A" AS SHOWN IN THE FOLLOWING DIAGRAM.
- THREAD TWO M8 X 20 BOLTS INTO THE SHORT T-NUT. (FIG-A) DO NOT TIGHTEN AT THIS TIME.
- THREAD TWO M8X 20 BOLTS THROUGH CROSS BAR BRACKET AND UPRIGHT INTO LONG T-NUT (FIG-B) DO NOT TIGHTEN AT THIS TIME.
- THREAD TWO M8X 14 BOLTS THROUGH CROSS BAR BRACKET INTO LONG T-NUT (FIG-B) DO NOT TIGHTEN AT THIS TIME.

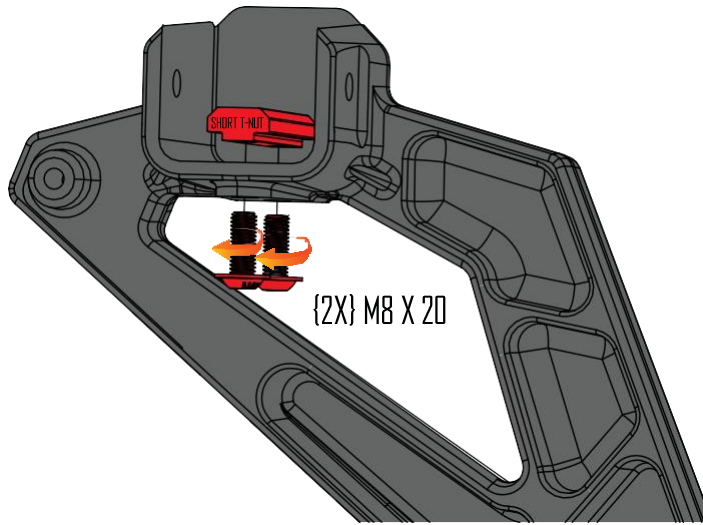

**FIG-A**

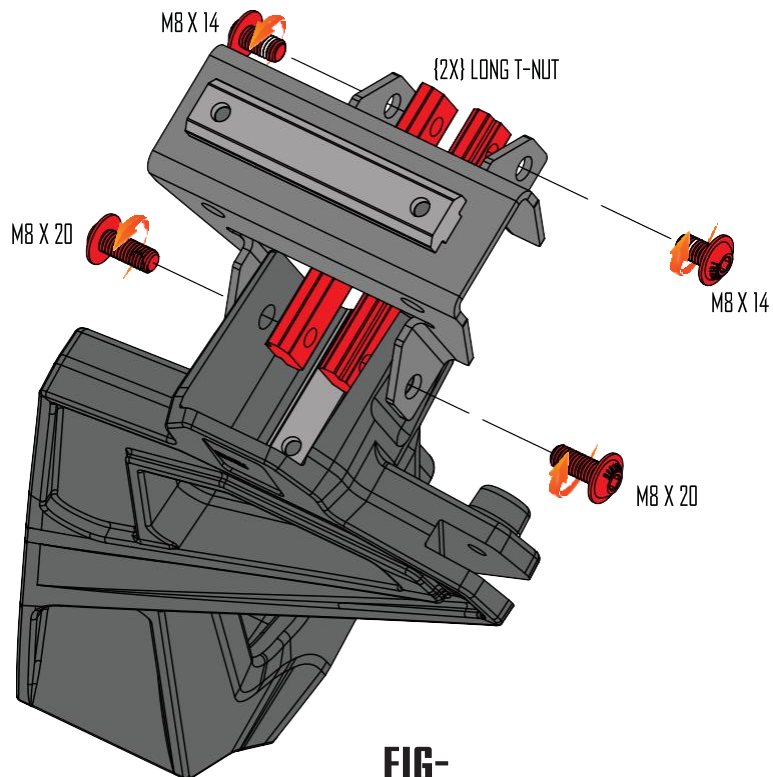

**FIG-B**



# ASSEMBLE PASSENGER SIDE: TOP BAR

· ATTACH A & B UPRIGHT ASSEMBLYS TO TOP BAR AS SHOWN IN ILLUSTRATION BELOW. DO NOT TIGHTEN BOLTS AT THIS TIME.

· **NOTE: MAKE SURE YOU SLIDE THE TWO (2) T-BOLTS INTO THE UPPER MOST T-TRACK**

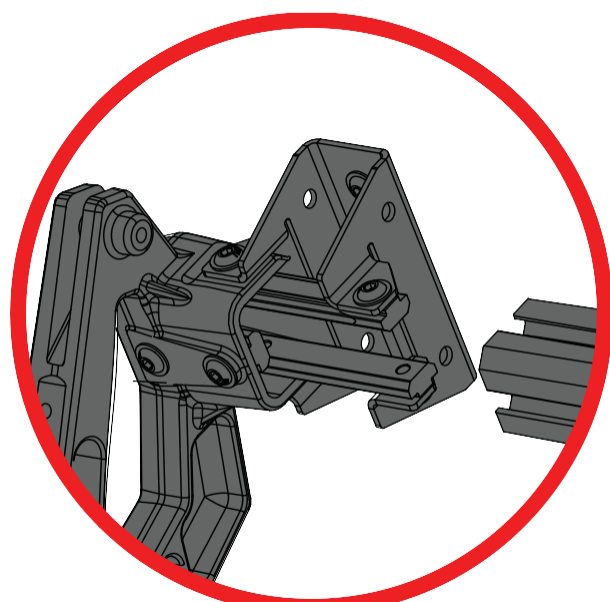
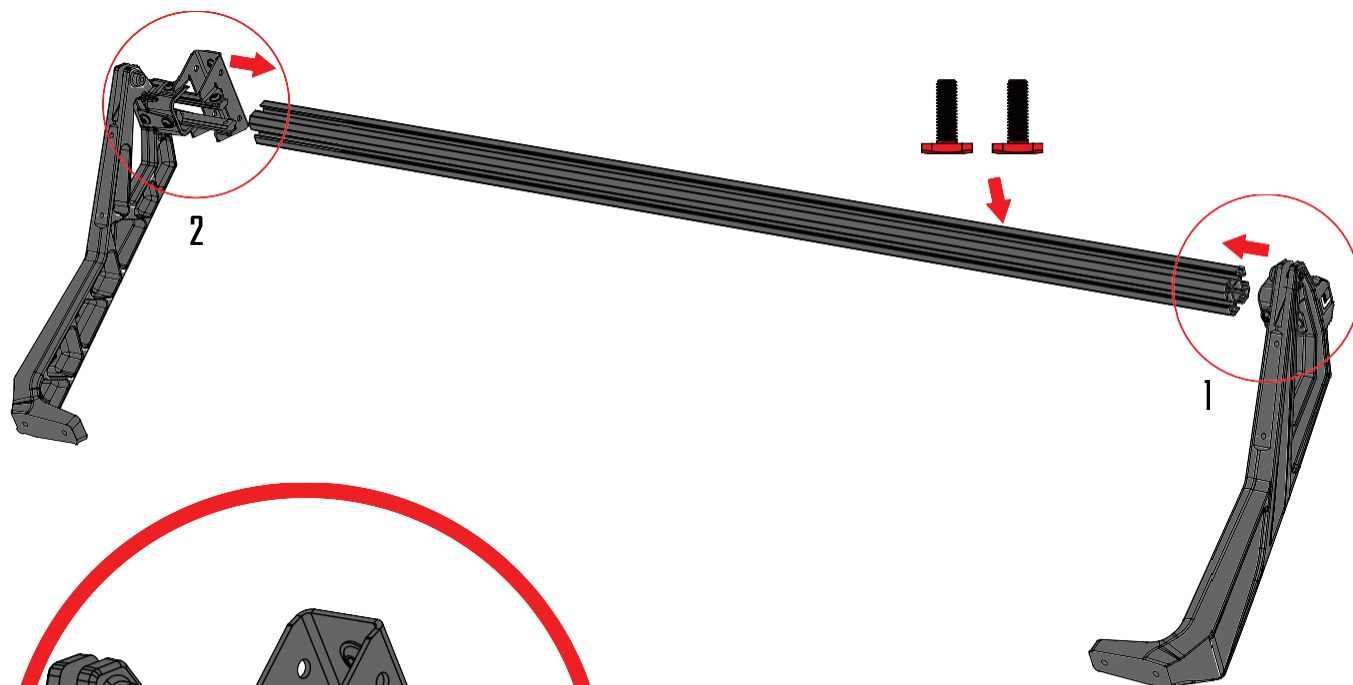

**DETAIL-2**

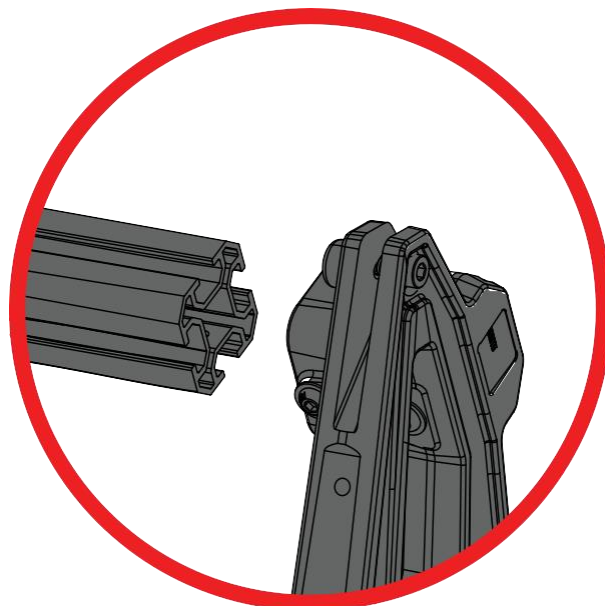

**DETAIL-1**

# ASSEMBLE PASSENGER SIDE: RAIL

- ATTACH RAIL TO UPRIGHTS USING FOUR M10 X 25 SCREWS. TORQUE TO 40 FT-LB USING A T40 TORX WRENCH.
- TORQUE ALL M8 BOLTS INSTALLED IN PREVIOUS STEP TO 14 FT-LB USING A T40 TORX WRENCH.
- **IMPORTANT: TIGHTEN M10X25 RAIL BOLTS FIRST THEN TORQUE THE M8 BOLTS.**

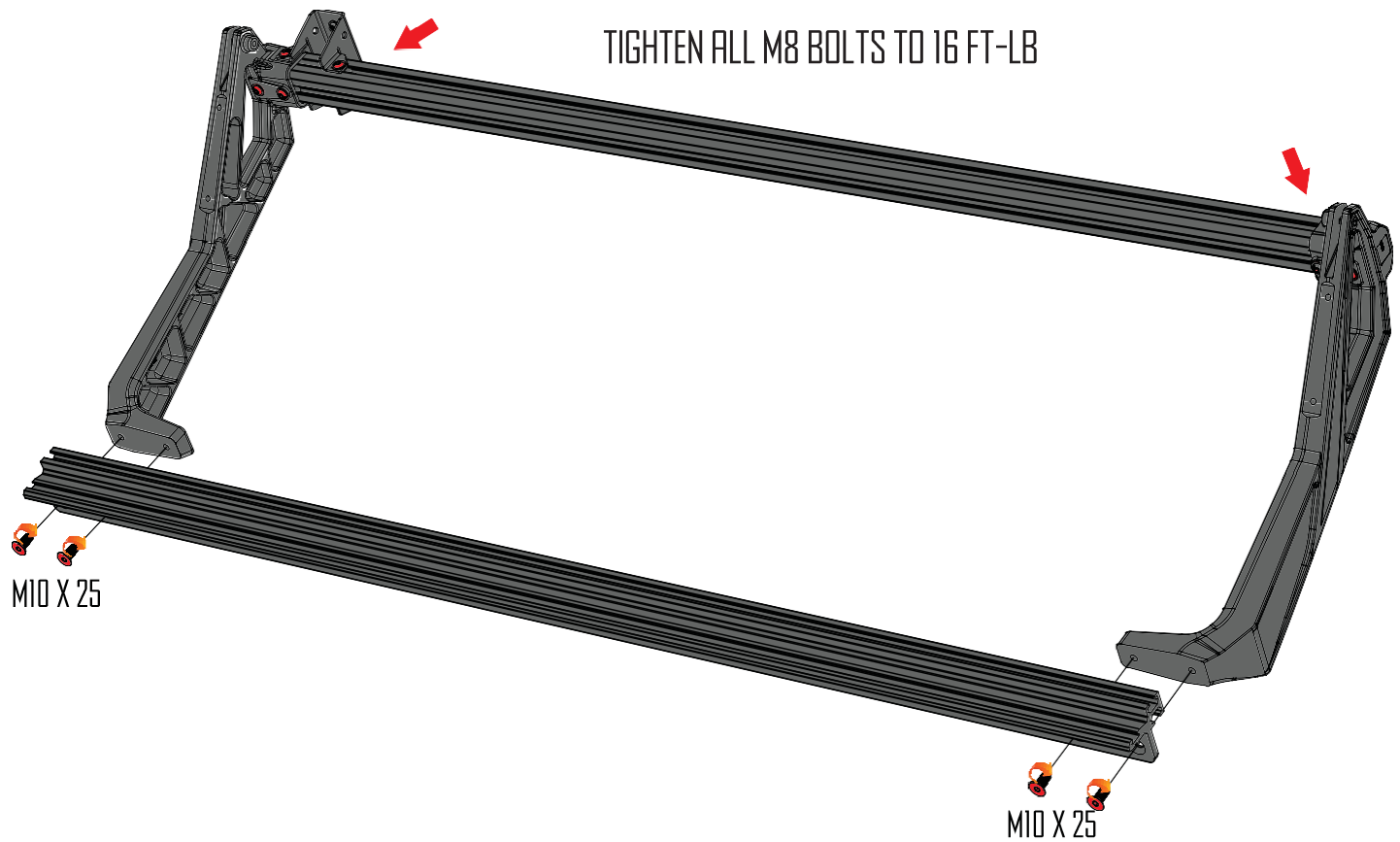

# ASSEMBLE: RAIL CLAMPS TO RAILS

- INSTALL THREE RAIL CLAMP ONTO THE PASSENGER AND DRIVERS SIDE RAIL THAT WERE ASSEMBLED IN PREVIOUS STEPS. THE RAIL CLAMP WILL SLIDE ONTO THE RAIL FROM EITHER END.

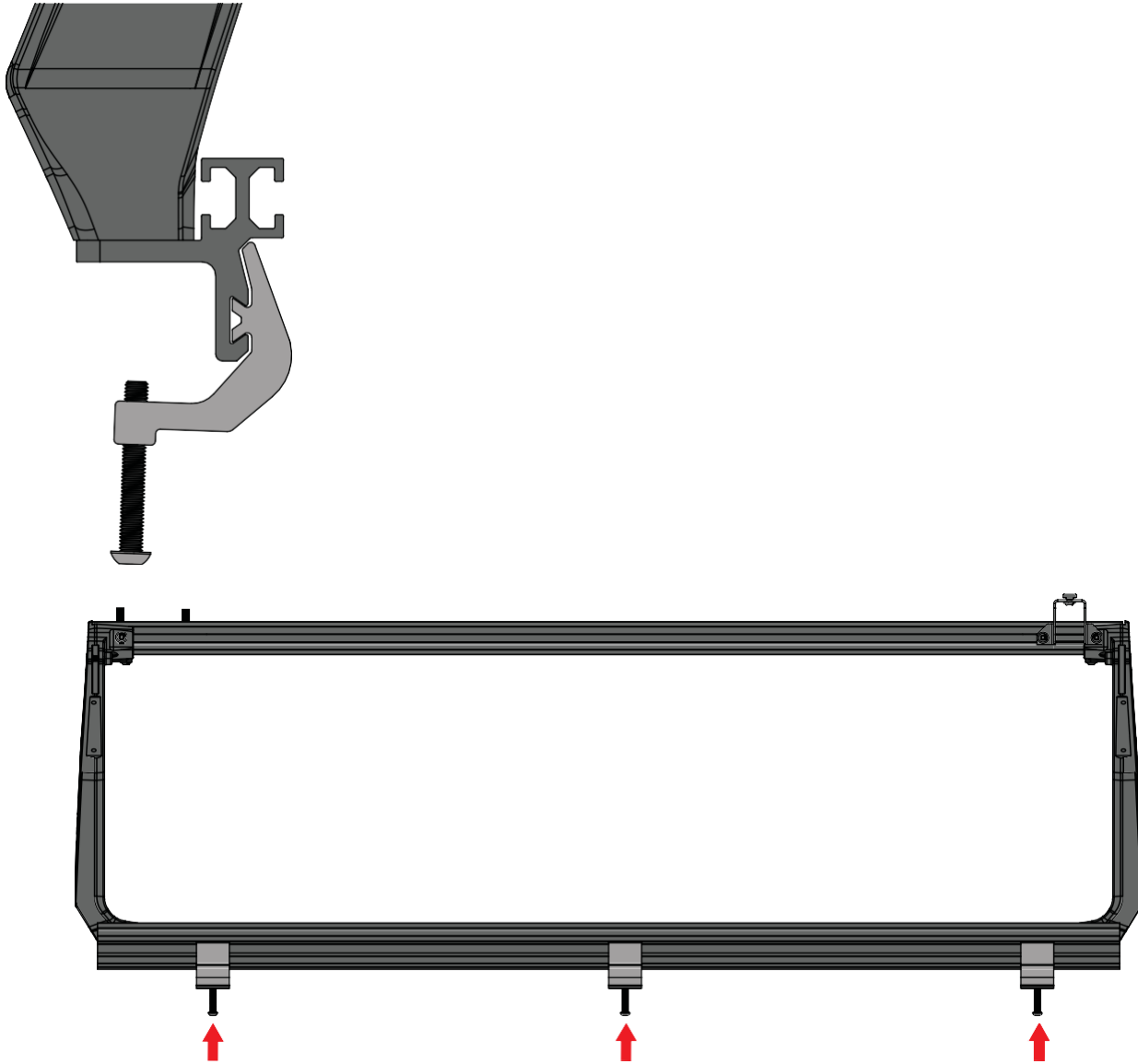

- NOTE: SOME TRUCK BEDS WILL NOT ALLOW THE CLAMPS TO BE SPACED EVENLY. IN THIS SITUATION IT MIGHT BE NECESSARY TO HAVE 2 CLAMPS NEXT TO EACH OTHER.

- NOTE: TOYOTA TUNDRAS AND NISSAN TITANS WILL REQUIRE REMOVAL OF THE ACCESSORY RAIL TO INSTALL ACS.

# INSTALL: RACK TO TRUCK

- PLACE THE DRIVERS SIDE ASSEMBLY ONTO THE BED RAIL OF THE TRUCK. **[THE STATIONARY CROSS BAR BRACKET WILL BE BY THE FRONT OF THE TRUCK]** ADJUST THE CLAMPS SO THEY ARE EVENLY SPACED AND AS FAR APART AS POSSIBLE. EVERY TRUCK BED IS DIFFERENT AND YOU WILL NEED TO ADJUST THE CLAMPS SO THAT THEY ARE AT THE DEEPEST POINT IN THE BED AND THE RAILS SIT FLUSH.
- PLACE ONE RAIL CLAMP SPACER (SHOWN IN RED) ON THE END OF EACH CLAMP BOLT. TIGHTEN BOLTS SO THAT RACK IS SELF SUPPORTING. YOU WILL ADJUST THE LOCATION OF THE RACK IN A FUTURE STEP SO DO NOT OVER TIGHTEN.
- REPEAT STEPS FOR PASSENGER SIDE.

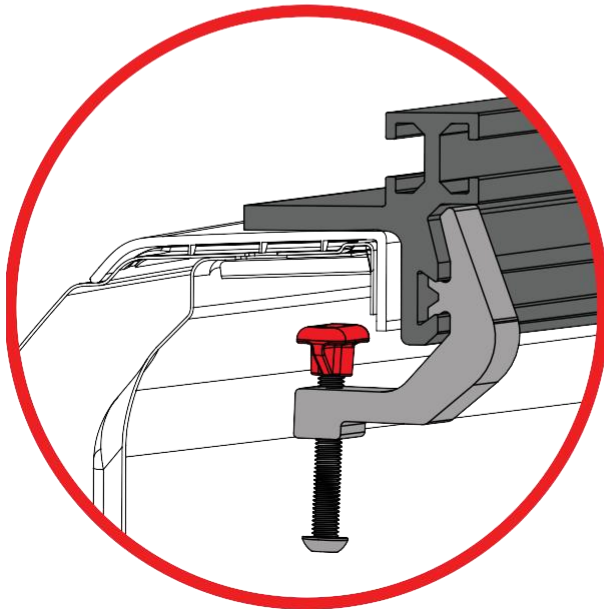
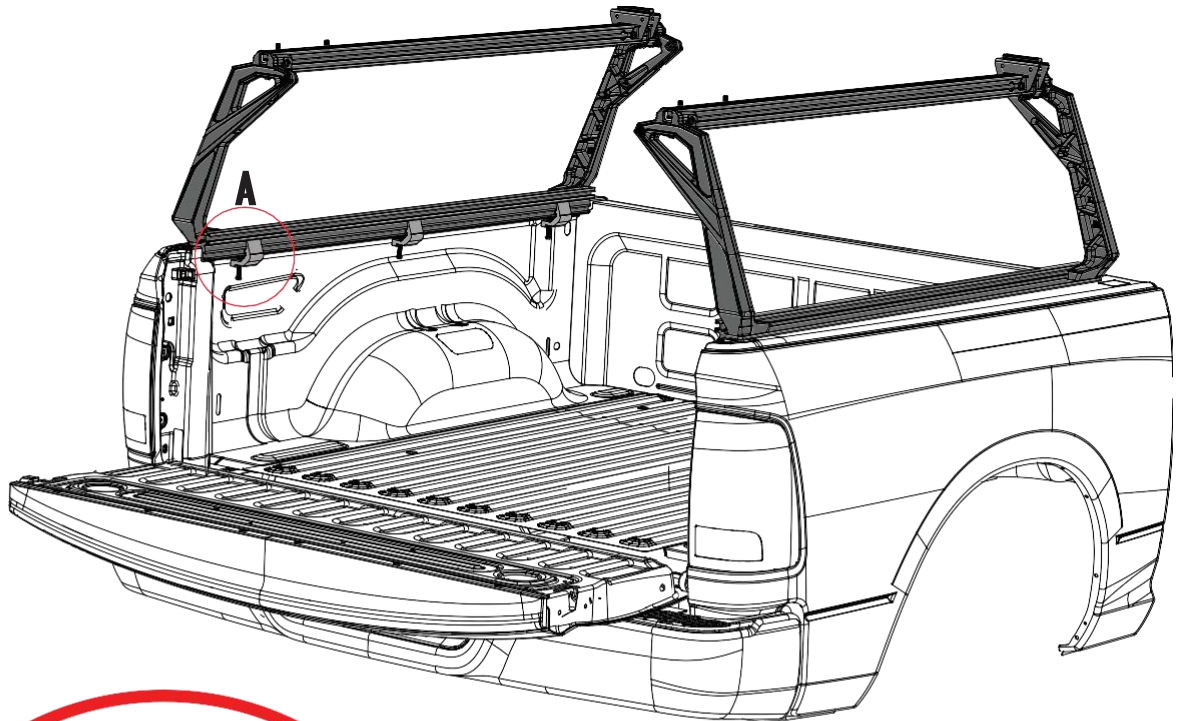

**DETAIL-A**

# ASSEMBLE: REAR UPRIGHT BRACES

- USING AN M8 X 25 BOLTS ATTACH REAR UPRIGHT BRACES AS SHOWN TO BOTH PASSENGER AND DRIVERS SIDE.
- SNUG BOLTS DOWN SO THAT THE UPRIGHT BRACES CAN STILL BE MOVED WITH SOME FORCE.

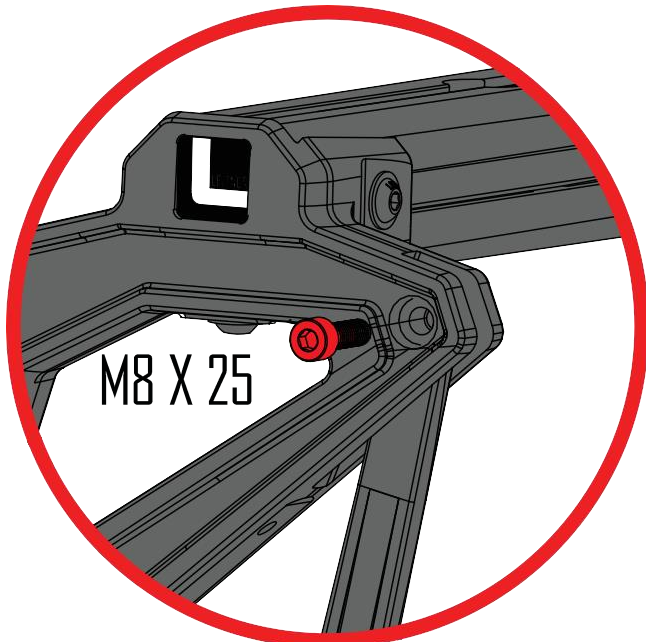
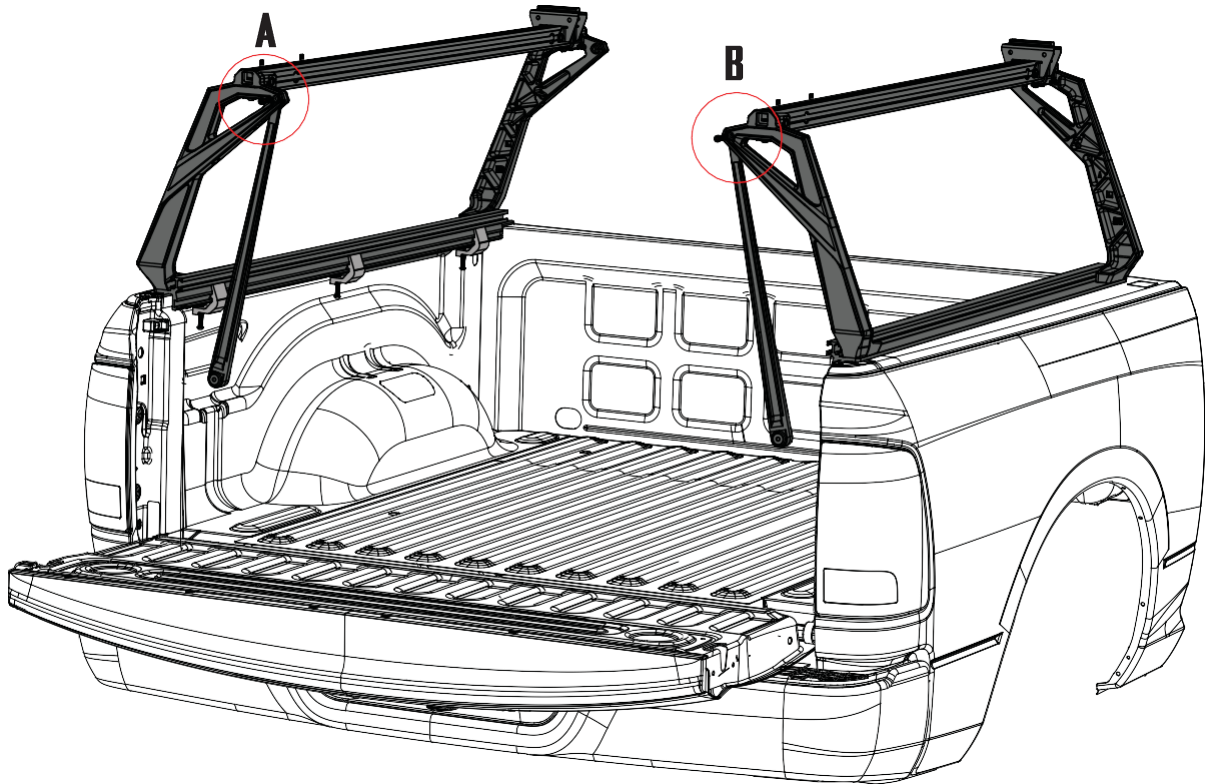

DETAIL-

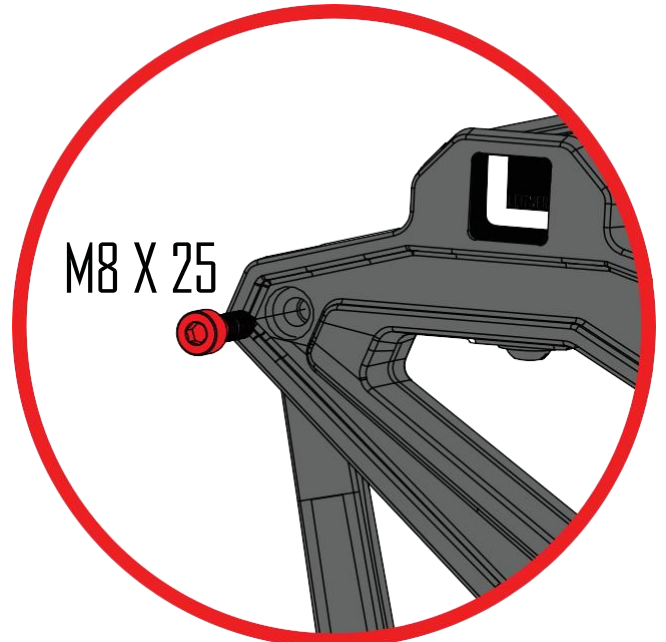

DETAIL-

# ASSEMBLE: UPRIGHT BRACE BRACKETS

• USING TWO M8 X 20 BOLTS ATTACH REAR UPRIGHT BRACE BRACKETS TO UPRIGHT BRACE AS SHOWN. REPEAT FOR OTHER SIDE. SNUG BOLTS SO THAT THE BRACKET CAN STILL BE MOVED WITH SOME FORCE. THIS WILL HELP HOLD THINGS IN PLACE FOR THE NEXT FEW STEPS.

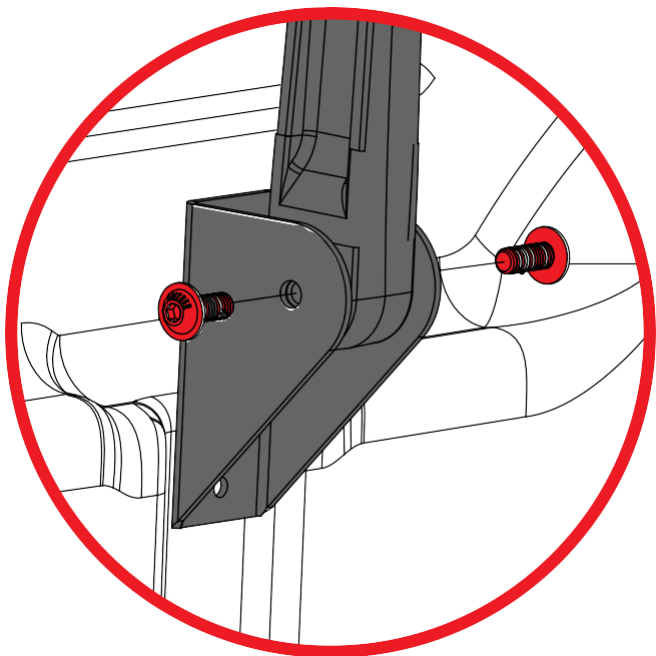
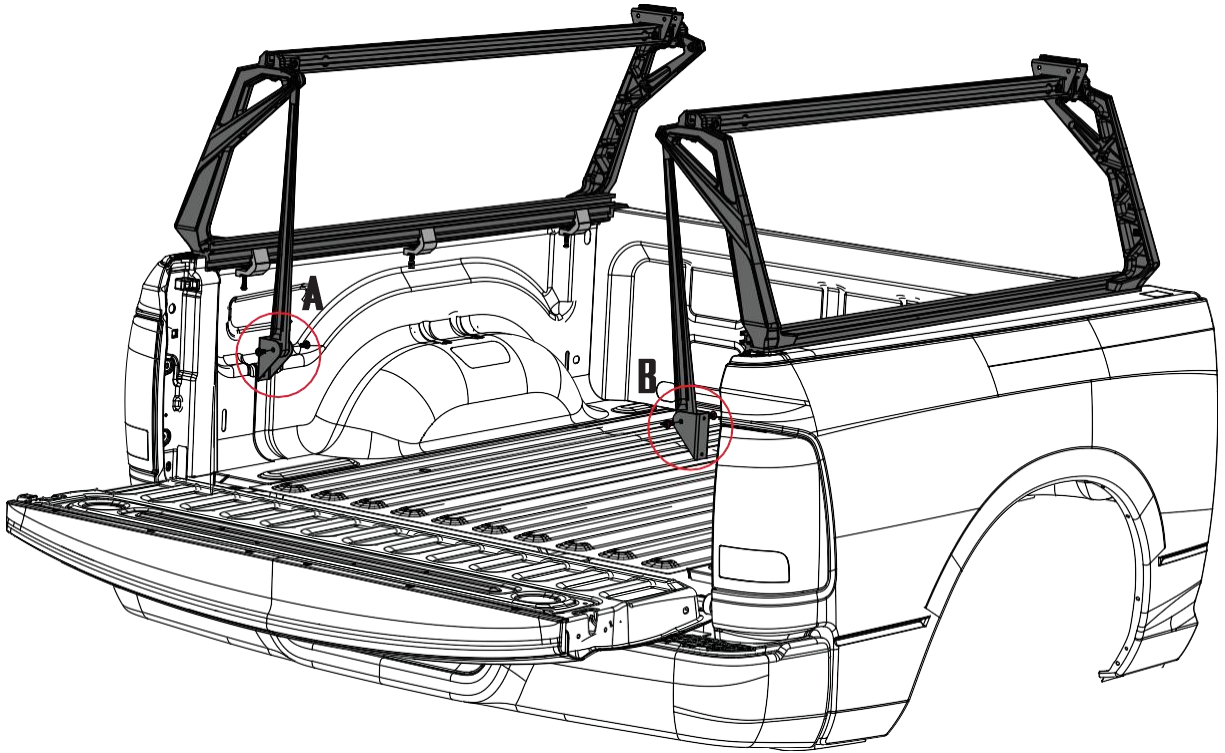

DETAIL-

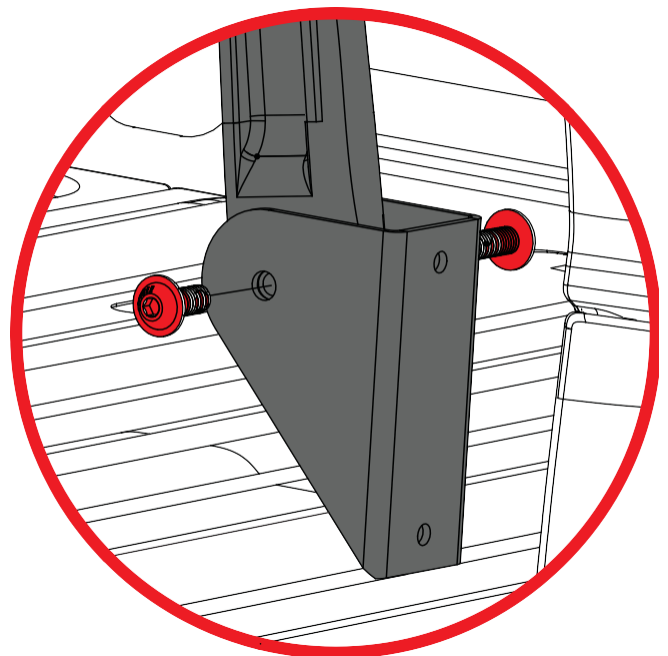

DETAIL-

# ALIGN: PASSENGER AND DRIVERS SIDE ASSEMBLY

• SLIDE THE PASSENGER AND DRIVERS SIDE ASSEMBLY FORWARD OR BACKWARDS SO THAT THE REAR UPRIGHT BRACE BRACKETS ARE CENTERED IN THE REAR D-PILLAR.

• TIGHTEN ALL THE RAIL CLAMP BOLTS TO (7 FT-LB)

• **CAUTION!!! DO NOT TIGHTEN RAIL CLAMP BOLTS OVER (7 FT-LB / 84IN-LB) GOING BEYOND THIS TORQUE VALUE COULD DAMAGE THE CLAMP SPACER.**

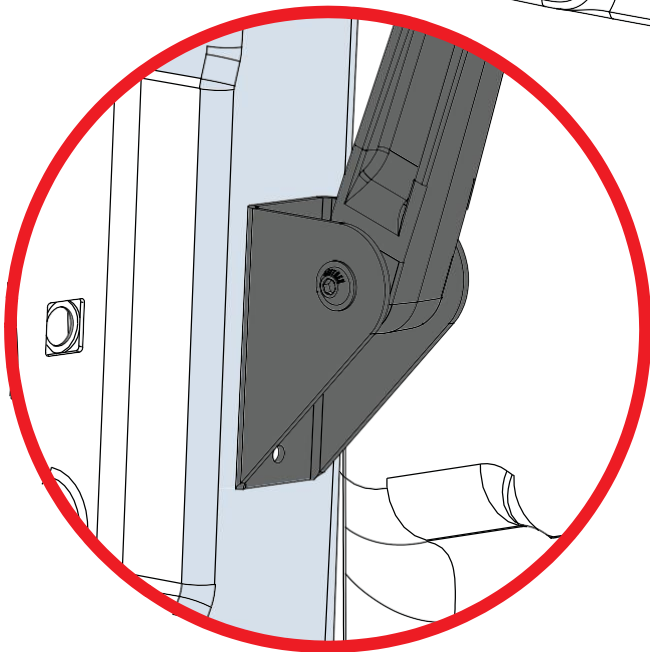
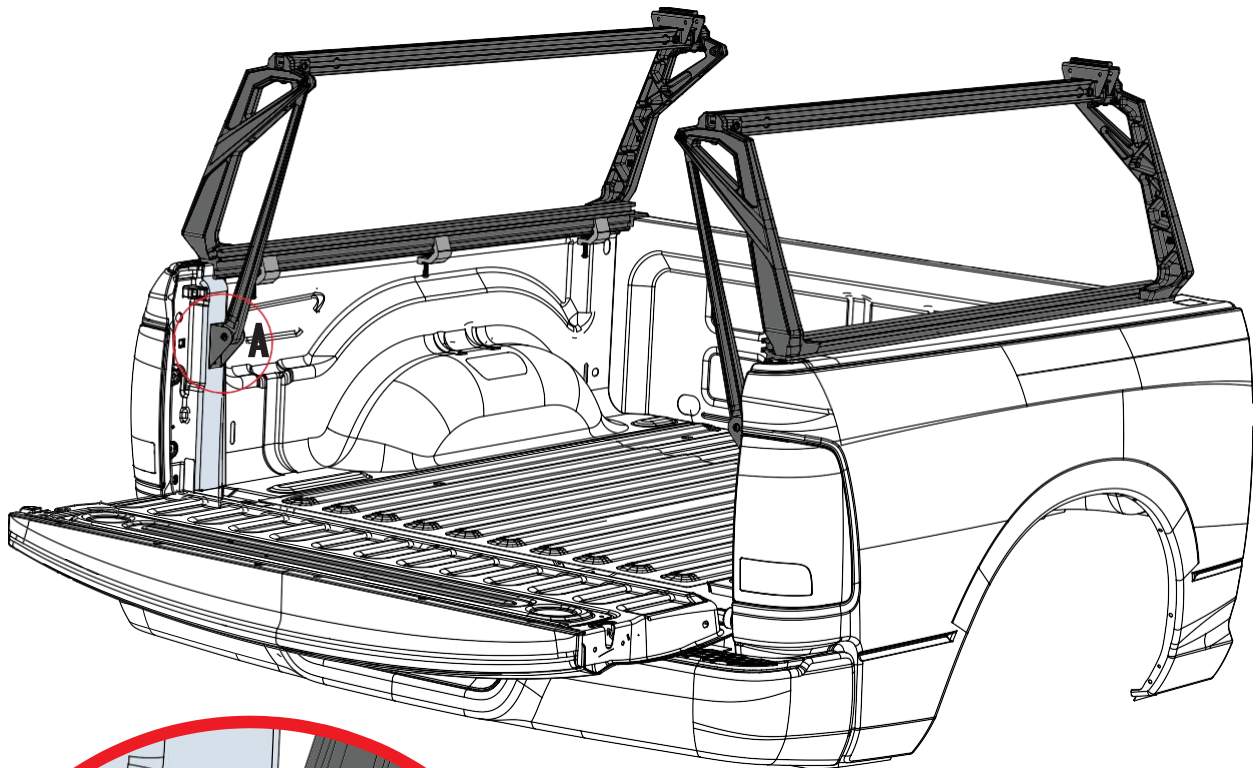

DETAIL-A

# ASSEMBLE: FRONT LOAD BAR TO BRACKETS

- SLIDE THE 60" LONG LOAD BARS ONTO THE T-NUTS IN THE STATIONARY LOAD BAR BRACKETS AND CENTER THEM ON THE RACK.
- TIGHTEN THE FOUR M8 SCREWS ON THE UNDERSIDE OF THE BRACKET USING A T40 TORX WRENCH.

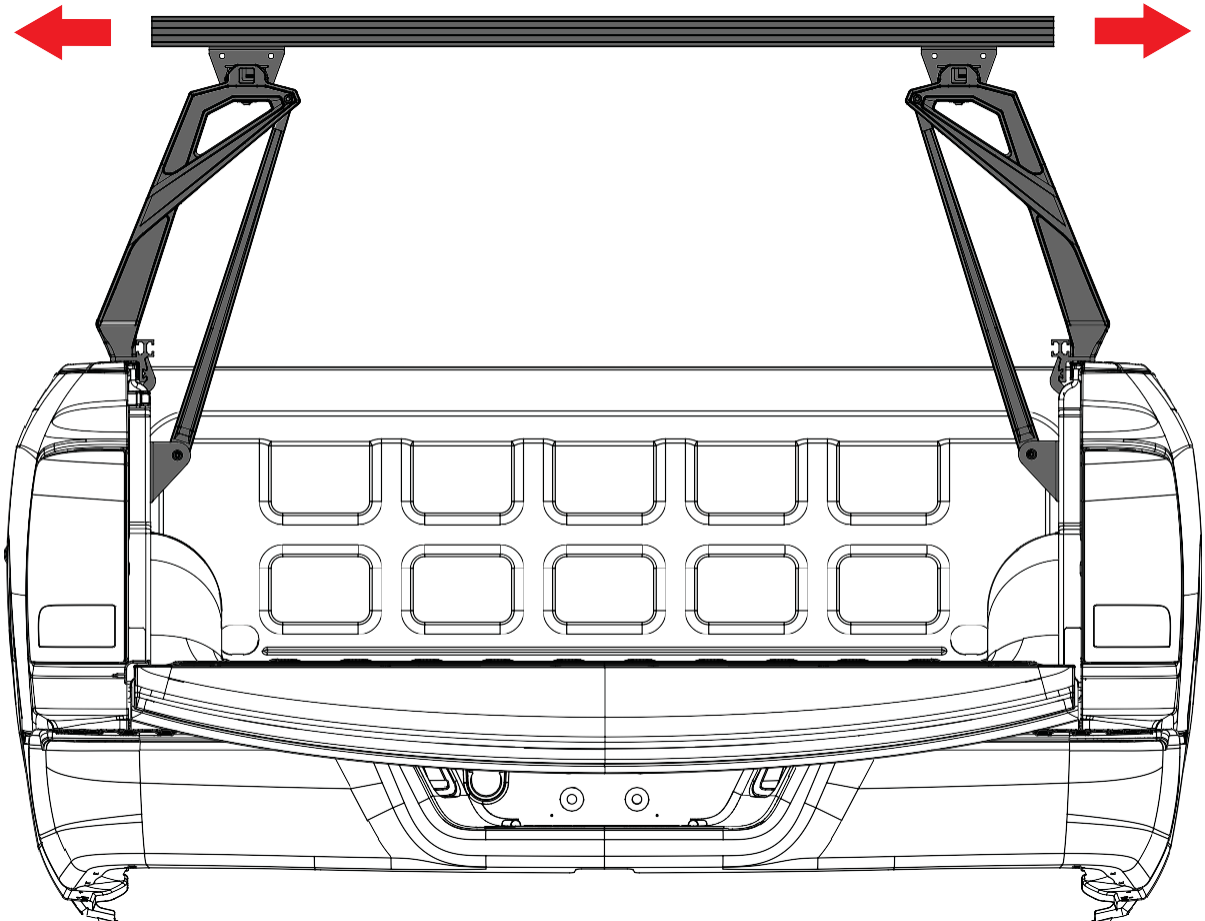
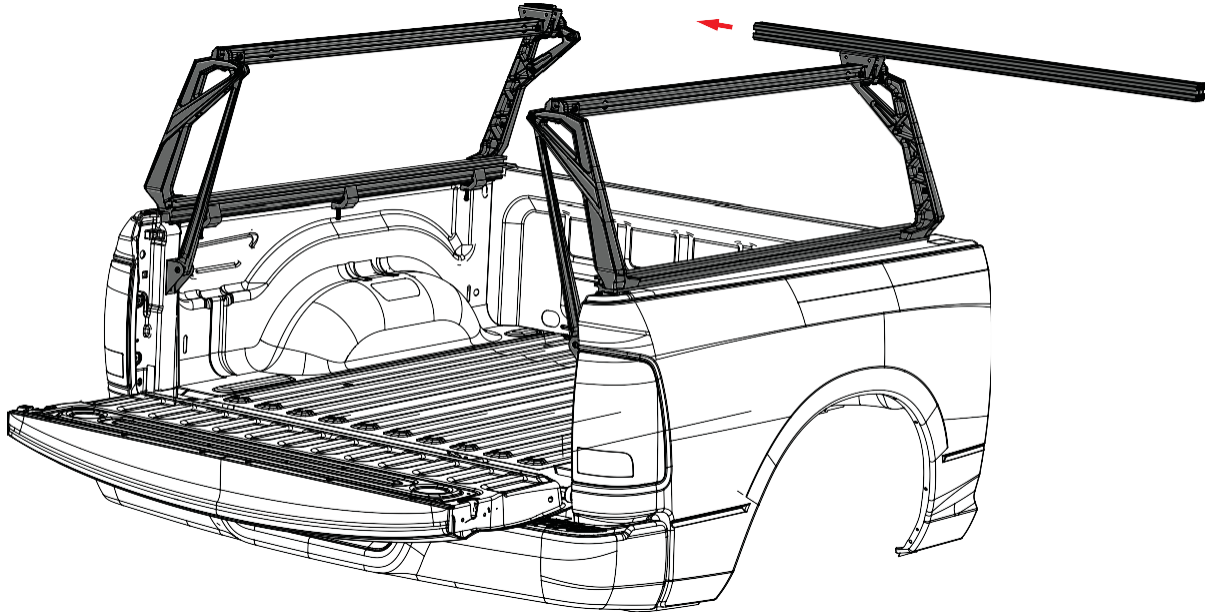



# ASSEMBLE: SLIDING LOAD BAR BRACKETS

• USING 2 RUBBER KNOBS PER SIDE, SECURE THE REAR CROSS BAR BRACKET AS FAR REARWARD AS POSSIBLE. [DETAIL A - B]

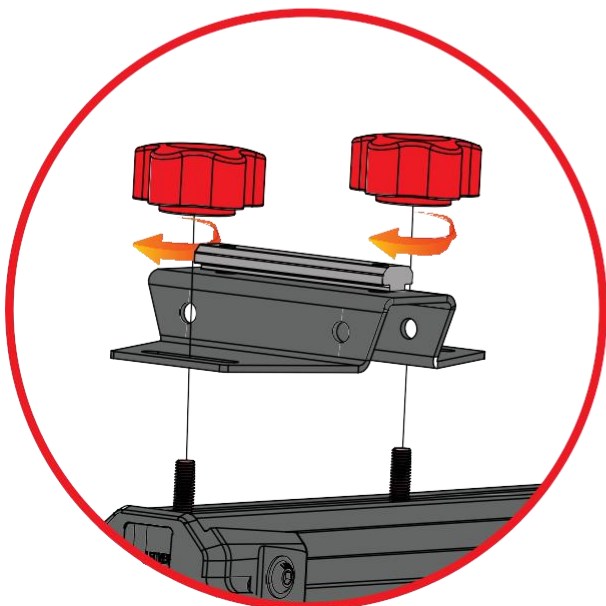
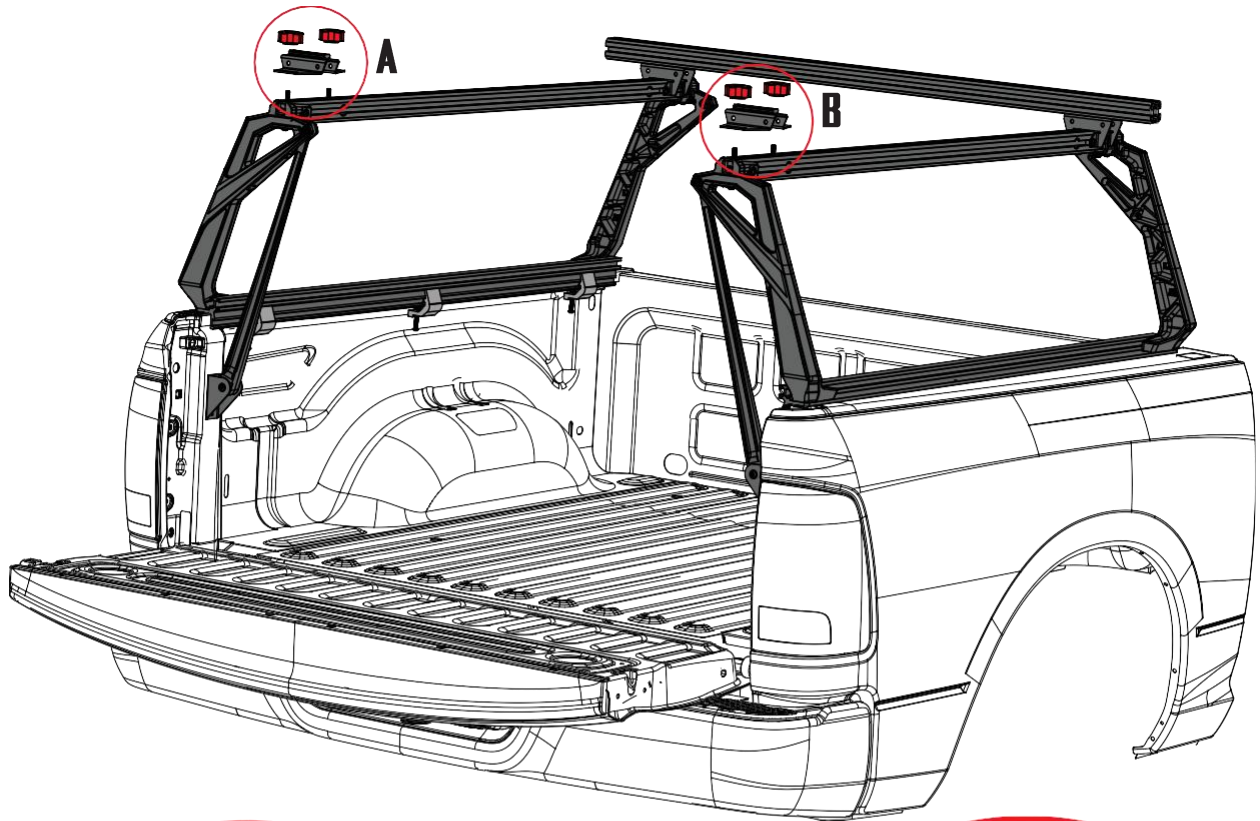

**DETAIL-A**

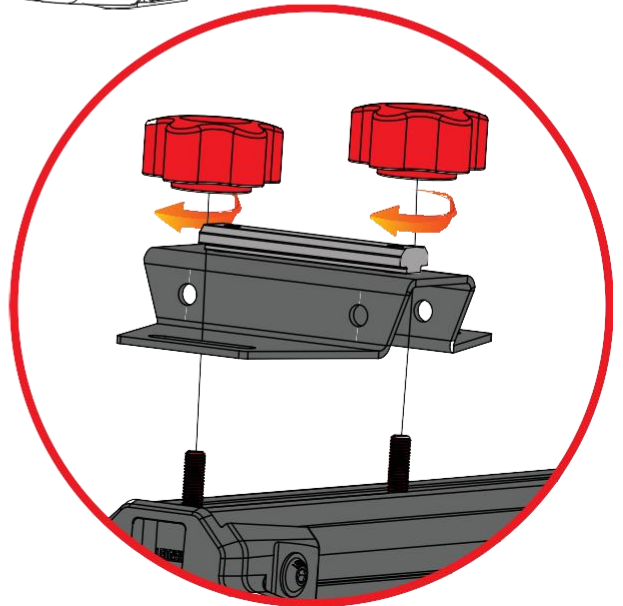

**DETAIL-B**

# ASSEMBLE: REAR LOAD BAR TO BRACKETS

• SLIDE THE 60" LONG LOAD BARS ONTO THE T-NUTS IN THE REAR LOAD BAR BRACKETS AND CENTER THEM ON THE RACK. **NOTE: DO NOT TIGHTEN THE BOLTS SECURING THE REAR LOAD BAR AT THIS TIME.**

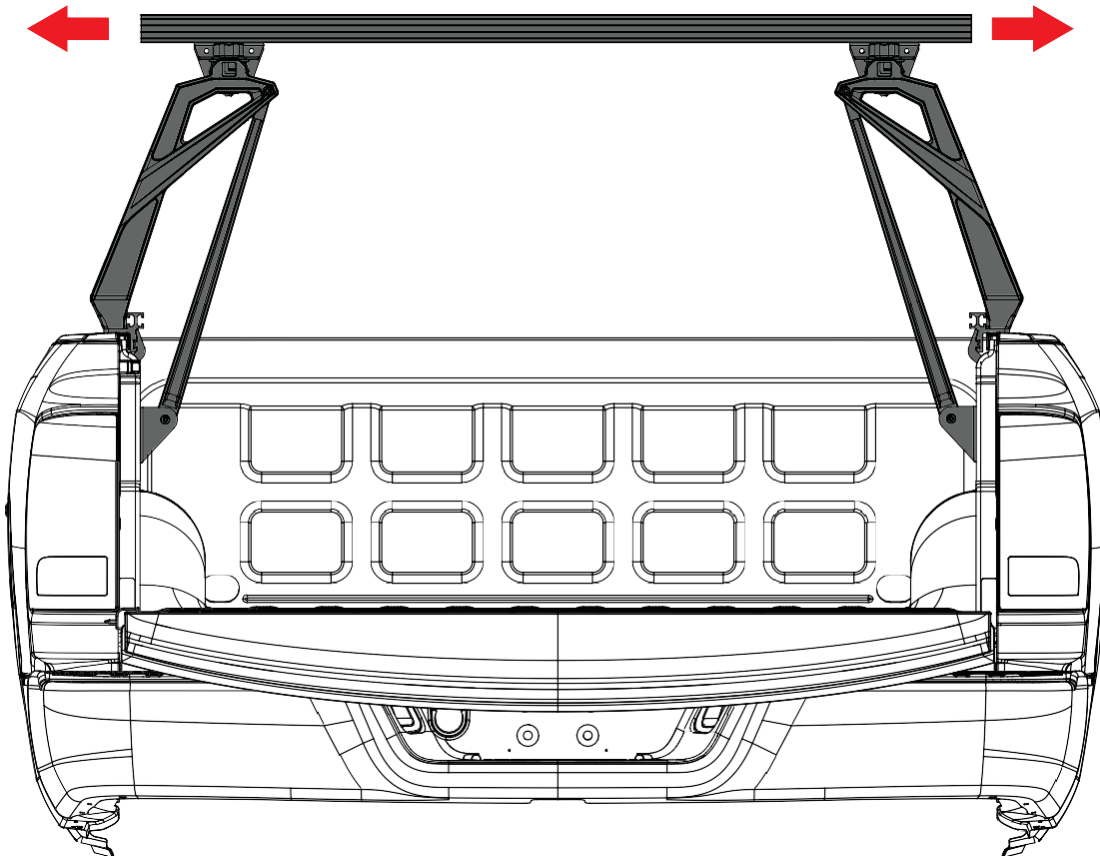
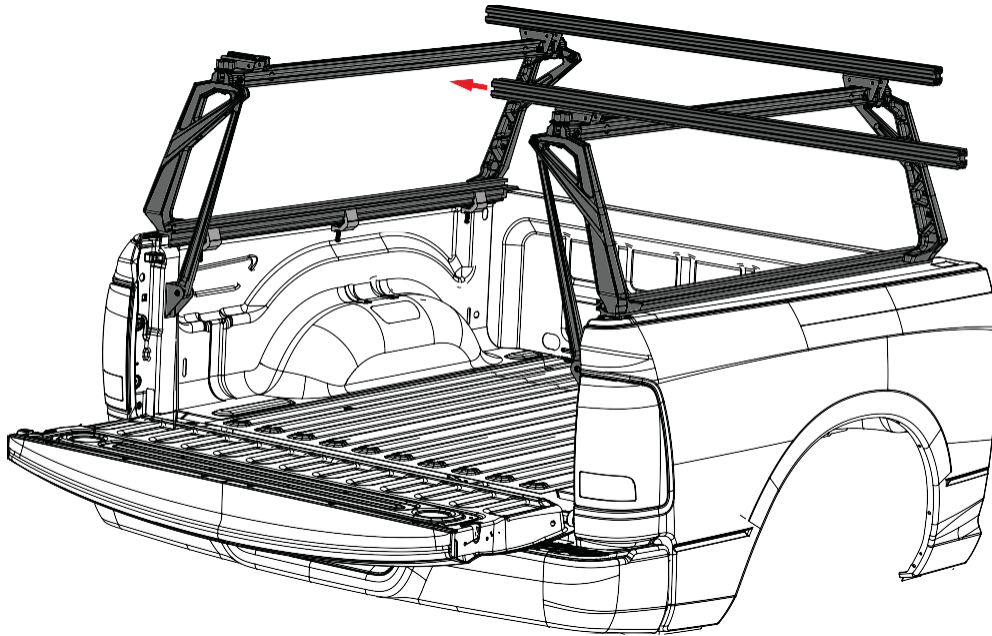

# MEASURE: WIDTH OF TRUCK BED-FRONT

• TO PROPERLY ALIGN THE ACTIVE CARGO SYSTEM YOU WILL NEED TO TAKE A FEW MEASUREMENTS BEFORE TIGHTENING THE T-BOLTS ON THE CROSS BARS.

• USING A TAPE MEASURE TAKE THE DIMENSION BETWEEN THE INSIDE T-SLOT RAILS ON THE PASSENGER AND DRIVERS SIDE LOWER RAILS AS FAR FORWARD AS POSSIBLE. **[A]** SUBTRACT 14.25" FROM THIS MEASUREMENT. THIS WILL GIVE YOU THE DESIRED WIDTH BETWEEN THE TOP LONG BAR EXTRUSIONS. **[B]**. TIGHTEN THE FOUR T-BOLTS ON THE UNDERSIDE OF THE CROSS BARS.

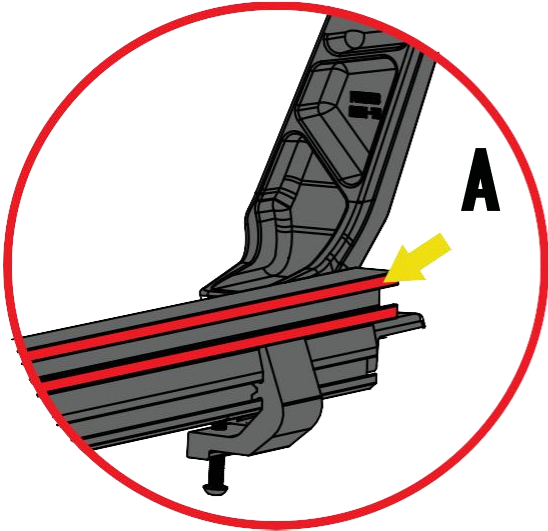
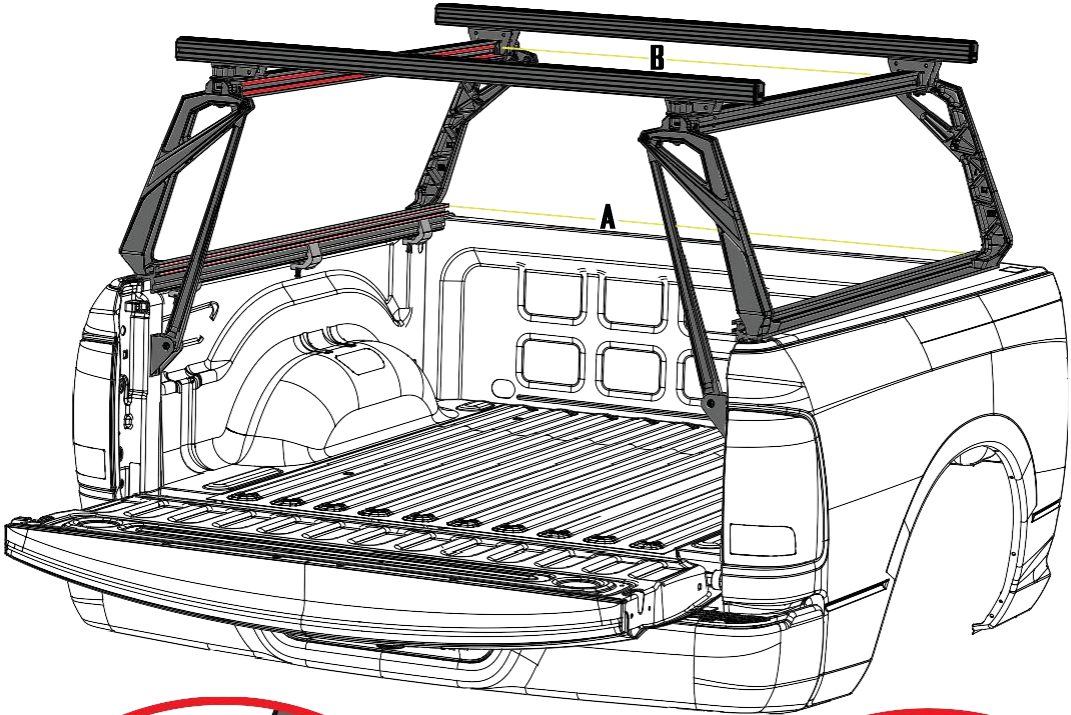

MEASURE TO THIS SURFACE ON BOTH SIDES

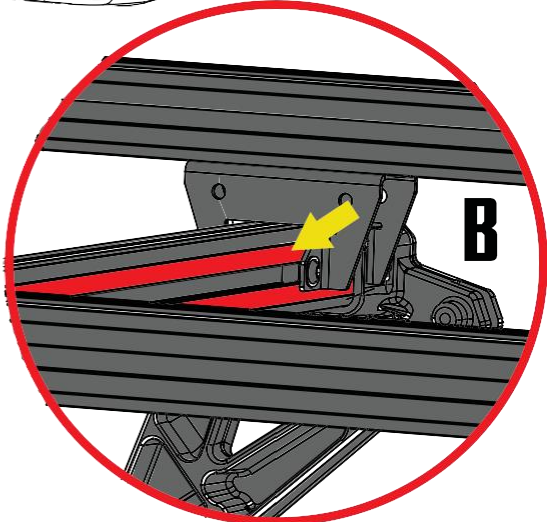

MEASURE TO THIS SURFACE ON BOTH SIDES

**- NOTE: MOST JAPANESE TRUCKS WILL BE CLOSE TO SQUARE FRONT TO BACK WHILE DOMESTIC PICKUP TRUCKS CAN BE AS MUCH AS 3" WIDER IN THE FRONT THEN IN THE BACK OF THE PICKUP BOX**

# MEASURE: WIDTH OF TRUCK BED-REAR

• USING A TAPE MEASURE TAKE THE DIMENSION BETWEEN THE INSIDE T-SLOT RAILS ON THE PASSENGER AND DRIVERS SIDE **LOWER RAILS** AS FAR REAR AS POSSIBLE. **[A]** SUBTRACT **14.25"** FROM THIS MEASUREMENT. THIS WILL GIVE YOU THE DESIRED WIDTH BETWEEN THE TOP LONG BAR EXTRUSIONS. **[B]**. TIGHTEN THE FOUR T-BOLTS ON THE UNDERSIDE OF THE CROSS BARS.

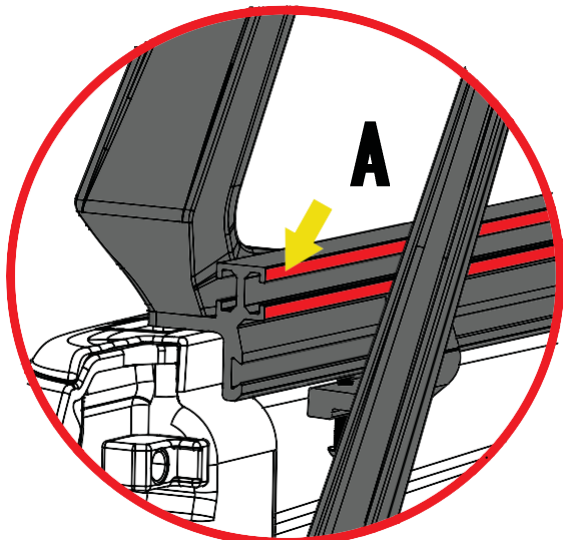
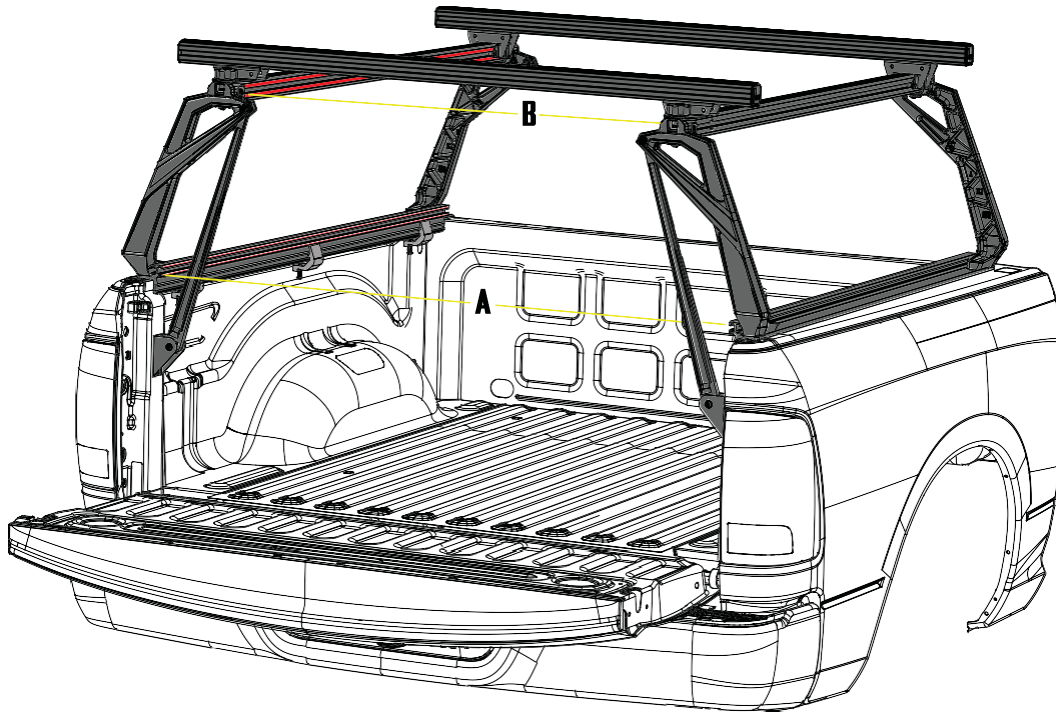

MEASURE TO THIS SURFACE ON BOTH SIDES

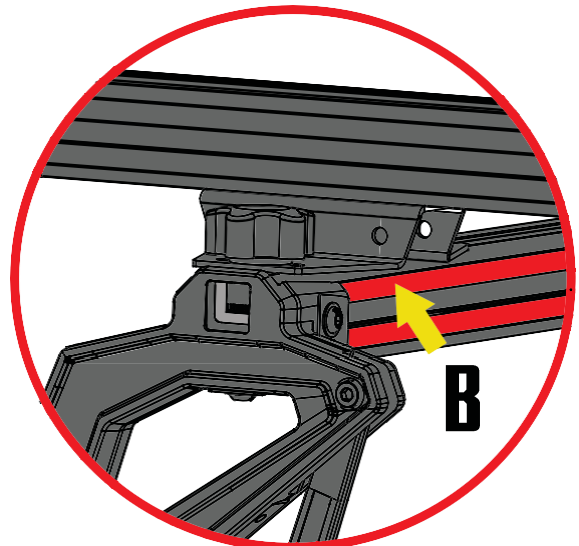

MEASURE TO THIS SURFACE ON BOTH SIDES

**- NOTE: MOST JAPANESE TRUCKS WILL BE CLOSE TO SQUARE FRONT TO BACK WHILE DOMESTIC PICKUP TRUCKS CAN BE AS MUCH AS 3" WIDER IN THE FRONT THEN IN THE BACK OF THE PICKUP BOX**

# DRILL: SUPPORT BRACKET HOLES

• IF YOU HAVE FOLLOWED ALL THE STEPS SO FAR AND THE RACK IS SQUARE ON THE TRUCK, IT IS TIME TO DRILL THE HOLES THAT WILL SECURE THE REAR UPRIGHT BRACES TO THE VEHICLE.

• USING A CENTER PUNCH MARK THE LOCATION OF THE LOWER REAR UPRIGHT BRACE BRACKET ON BOTH SIDES OF THE TRUCK. (DETAIL - A)

• NOTE :ALTERNATIVELY YOU CAN USE THE HOLE IN THE BRACKET AS A GUIDE AND DRILL A PILOT HOLE WITH A 1/4" BIT.

• NOW ROTATE THE SUPPORTS OUT OF THE WAY AND FINISH DRILL THE HOLES WITH THE **INCLUDED 25/64TH DRILL**.

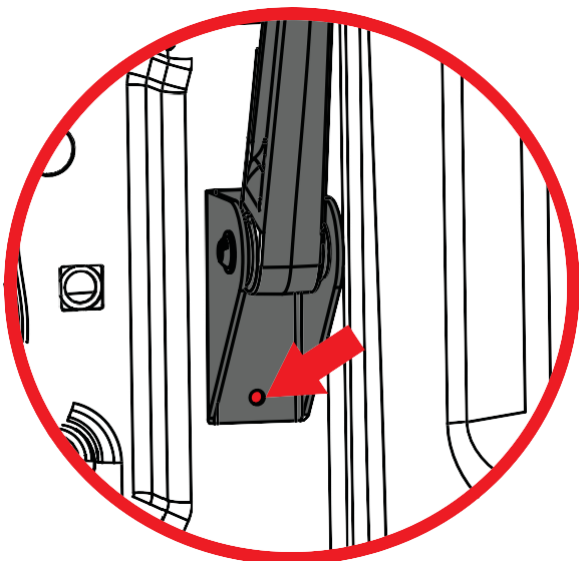
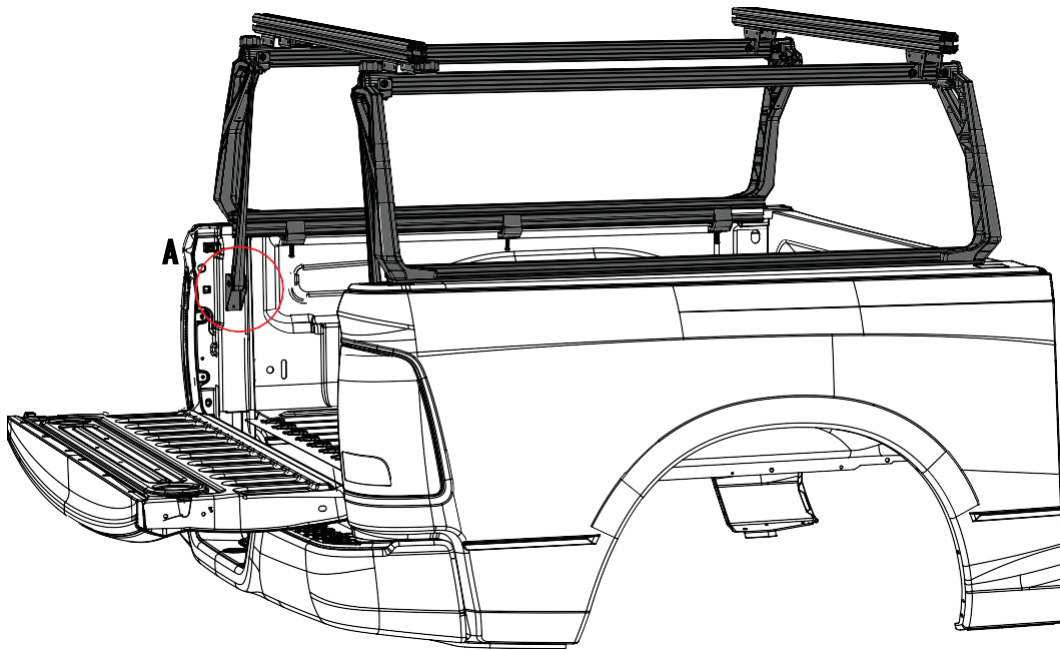

**DETAIL - A**

# INSTALL: THREADED INSERTS (RIVET NUTS)

- IN THE NEXT FEW STEPS YOU WILL BE INSTALLING FOUR RIVET NUTS. WE HAVE PROVIDED TWO EXTRA IN CASE YOU MAKE A MISTAKE.
- ENSURE THAT YOUR RIVET NUT SETTING TOOL IS PROPERLY ASSEMBLED USING THE SUPPLIED M6 X 25 BOLT AND WASHER. **[FIG - A]**
- INSERT THE RIVET NUT WITH INSTALL TOOL INTO THE HOLES YOU DRILLED PREVIOUSLY **[FIG - B]**. USING A 13MM WRENCH HOLD THE TOOL FROM ROTATING. **TIGHTEN THE BOLT WITH A 10MM SOCKET OR WRENCH UNTIL IT STOPS TURNING.** **[FIG - C]** YOU CAN USE A 1/4" ELECTRIC IMPACT FOR THIS BUT BE CAREFUL NOT TO STRIP THE THREADS.
- **NOTE: THE SETTING TOOL WILL BE STUCK TO THE RIVET AFTER INSTALLATION. A TAP WITH A HAMMER OR WRENCH WILL BREAK IT FREE.**

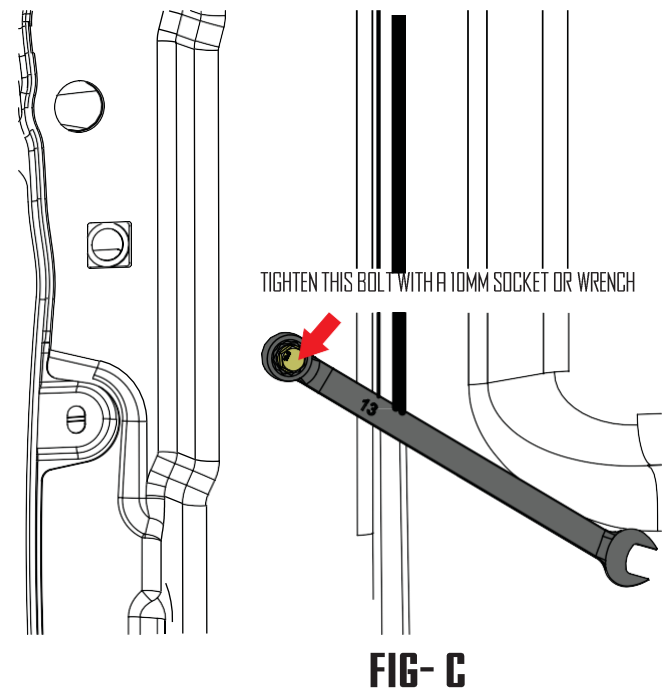
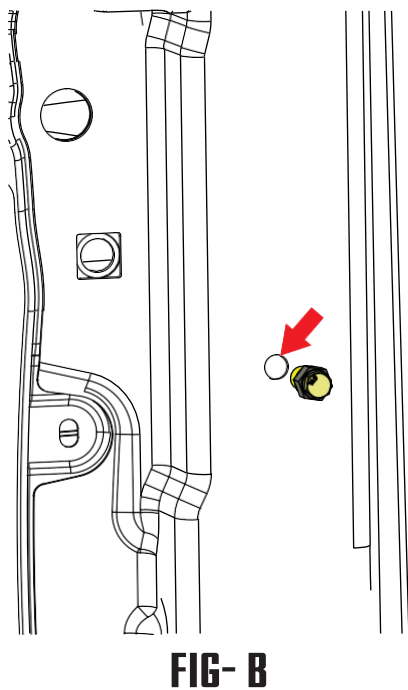
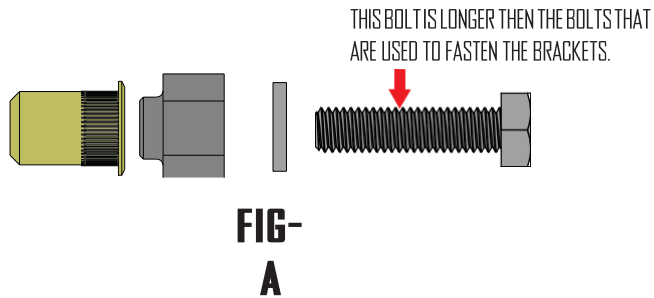

**- NOTE: IF YOUR TRUCK HAS A SPRAYED IN BED LINER YOU WILL NEED TO REMOVE THE MATERIAL AROUND THE DRILLED HOLE AT A 45 BEVEL SO THAT THE HEAD OF THE RIVET WILL SIT FLUSH AGAINST THE SHEET METAL OF THE TRUCK. A SHARP KNIFE WORKS GREAT FOR THIS.**

# INSTALL: UPRIGHT BRACE BRACKET BOLTS

• USING THE M6 X 20 BOLTS FASTEN THE REAR UPRIGHT BRACE BRACKETS ON DRIVER AND PASSENGER SIDE INTO THE RIVET NUTS INSTALLED IN PREVIOUS STEP.

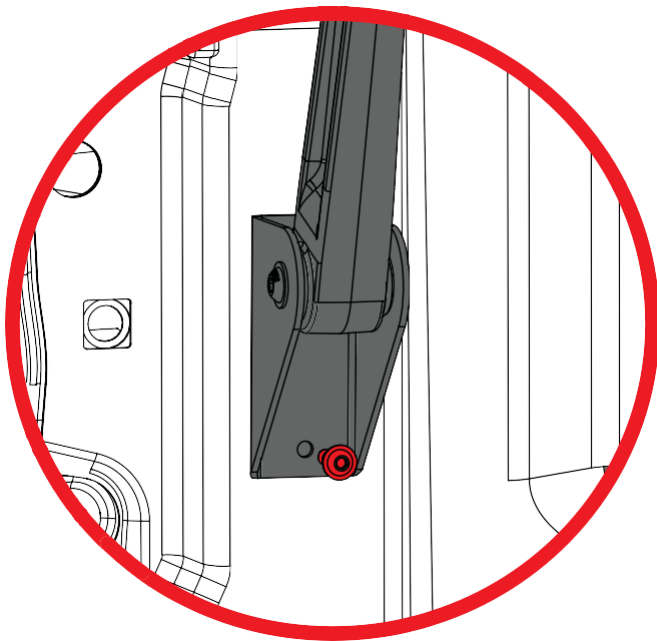
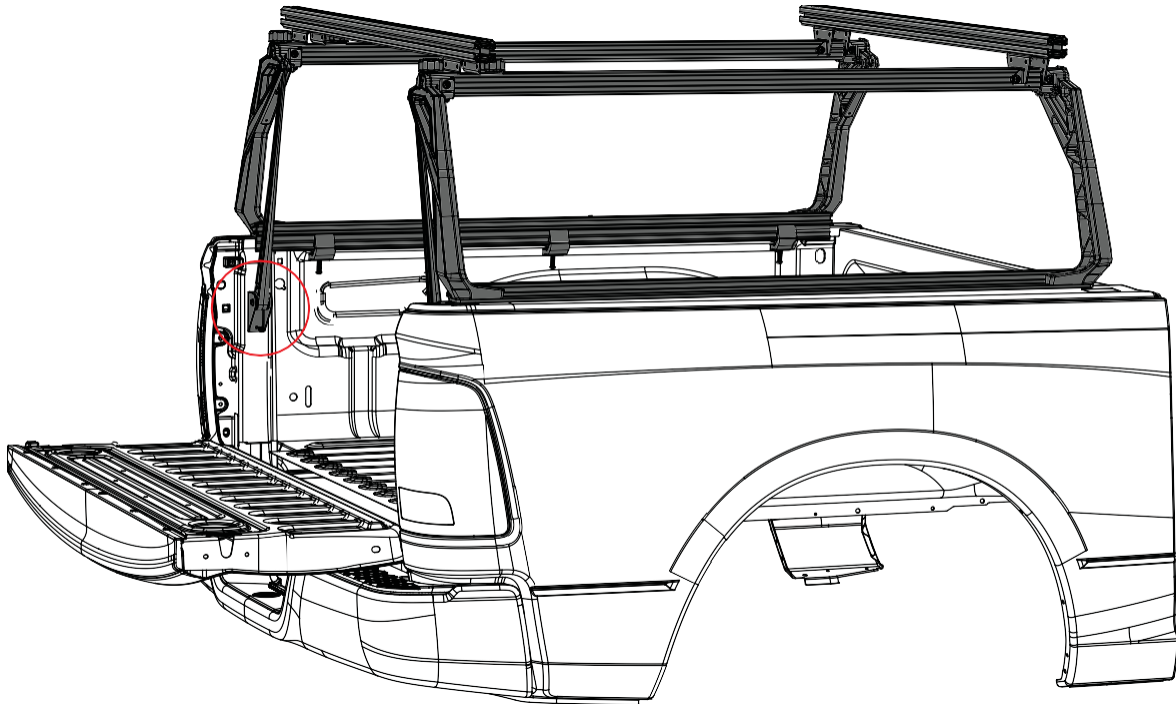

# DRILL: UPPER UPRIGHT BRACE BRACKET HOLE.

- REMOVE THE TWO M8 X 20 BOLT SSECURING THE REAR UPRIGHT BRACE TO THE UPRIGHT BRACE BRACKET. **[DETAIL - A]**
- SWING THE BRACE OUT OF THE WAY TO REVEAL THE UPPER HOLE. **NOTE: MAKE SURE THE BRACKET DOES NOT MOVE.**
- CENTER PUNCH THE UPPER HOLE. TWIST THE SUPPORT BRACKET AROUND THE LOWER BOLT TO GAIN ACCESS FOR DRILLING THE 25/64TH HOLE. **[DETAIL - B]**
- INSTALL RIVET NUT AS IN PREVIOUS STEPS.
- USING THE M6 X 20 BOLTS FASTEN THE REAR UPRIGHT SUPPORT BRACKET
- SWING BRACE BACK INTO PLACE AND REINSTALL M8 X 20 BOLTS. REPEAT FOR OTHER SIDE.

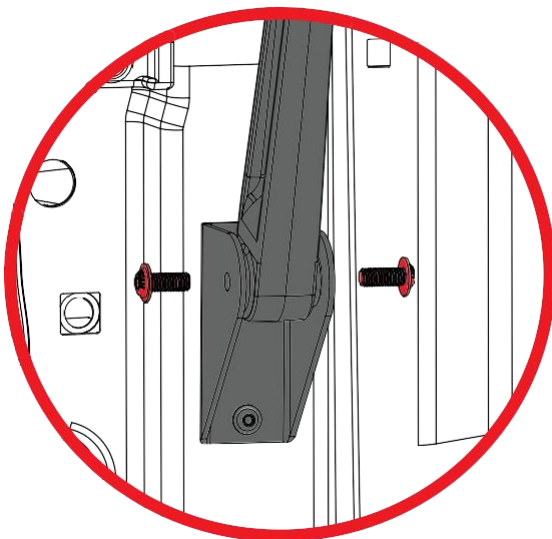
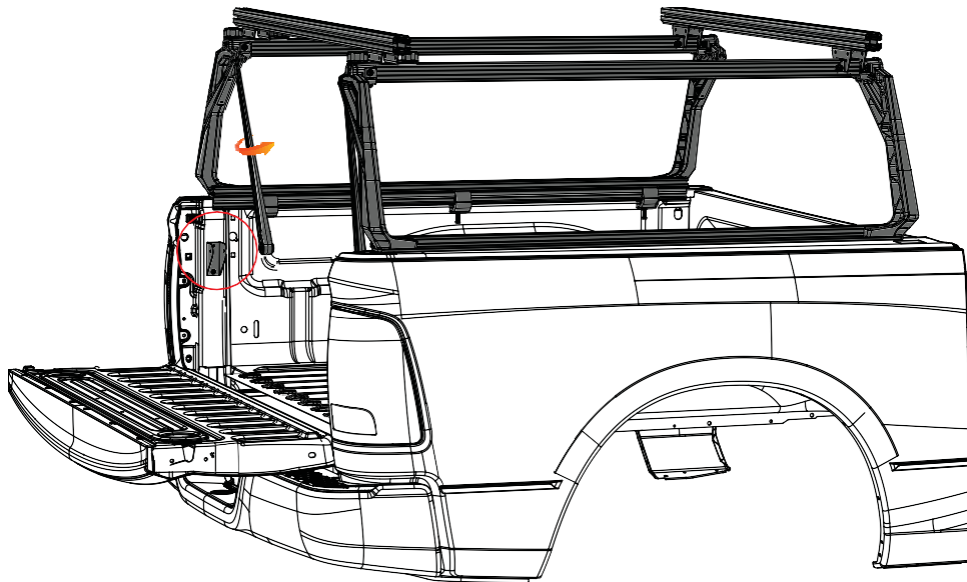

**DETAIL - A**

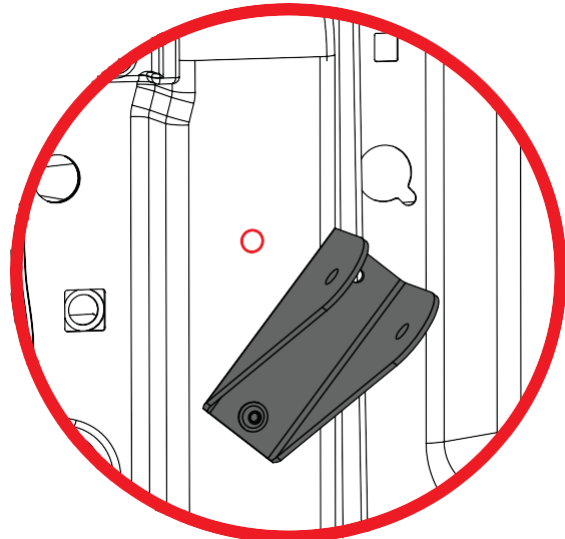

**DETAIL - B**



# FINISH: INSTALL END CAPS AND RUBBER TREAD STRIP

• INSTALL THE RUBBER TREAD STRIP INTO THE UPPER CROSS BAR CHANNEL BY PUSHING IT INTO THE T-SLOT WITH THE PALM OF YOUR HAND. NOTE: SOME TRIMMING OF THE RUBBER TREAD STRIP MIGHT BE NECESSARY.

• INSTALL THE FOUR END CAPS INTO THE ENDS OF THE CROSS BARS.

**CHECK ALL FASTENERS INSTALLED IN PREVIOUS STEPS TO ENSURE THEY ARE PROPERLY**

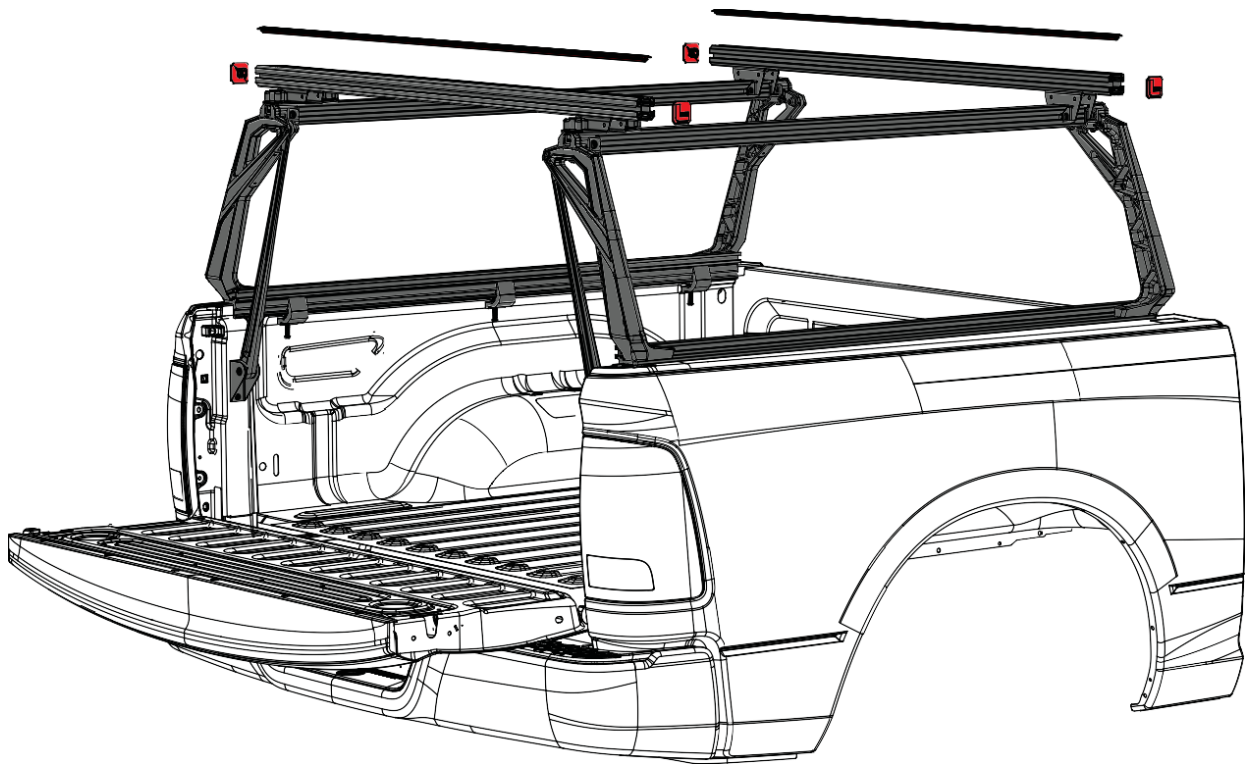

# USE GUIDELINES

WHEN USING LEITNER DESIGNS CARRIERS AND ACCESSORIES, THE USER MUST UNDERSTAND THE PRECAUTIONS. THE POINTS LISTED BELOW WILL ASSIST YOU IN USING THE RACK SYSTEM AND WILL ENCOURAGE SAFETY.

-FOR QUALITY FITS AND SAFETY, USE ONLY THE RECOMMENDED RACK OR ACCESSORIES. DO NOT ASSUME A RACK WILL FIT, ALWAYS CHECK THE CURRENT FIT GUIDE WHEN OBTAINING A NEW VEHICLE.

-THE MAXIMUM LOAD IS NOT TO BE EXCEEDED. (250# OFF ROAD – 500# ON ROAD). HOWEVER, THIS LIMIT IS ALWAYS SUBORDINATE TO THE MAXIMUM LOAD RECOMMENDED BY THE MANUFACTURER OF THE VEHICLE ITSELF. IT IS ALWAYS THE LOWER MAXIMUM RECOMMENDED LOAD THAT APPLIES. MAX TRUCK LOAD = LOAD CARRIER WEIGHT + ANY FITTED CARRIER ACCESSORIES + THE WEIGHT OF THE LOAD ITSELF.

**-HIGH SPEED OFF ROAD DRIVING EVEN WITH A LIGHT LOAD CAN CAUSE DAMAGE TO THE RACK, ACCESSORIES AND VEHICLE BODY. DAMAGE CAUSED BY HIGH SPEED DRIVING AND ABUSE IS NOT COVERED UNDER WARRANTY.**

-MAKE SURE ALL KNOBS, BOLTS, SCREWS, STRAPS, AND LOCKS ARE FIRMLY ATTACHED, TIGHTENED AND LOCKED BEFORE EVERY TRIP. KNOBS, BOLTS, SCREWS, STRAPS AND LOCKS MUST BE PERIODICALLY INSPECTED FOR SIGNS OF WEAR, CORROSION, AND FATIGUE. CHECK YOUR LOAD AT STOPS DURING THE TRIP TO ENSURE CONTINUED FASTENING SECURITY.

-CHECK LOCAL AND STATE LAWS GOVERNING PROJECTION OF OBJECTS BEYOND THE PERIMETER OF A VEHICLE. BE AWARE OF THE WIDTH AND HEIGHT OF YOUR CARGO SINCE LOW CLEARANCE BRANCHES, BRIDGES, AND PARKING GARAGES CAN AFFECT THE LOAD. ALL CARGO WILL AFFECT THE VEHICLE'S DRIVING BEHAVIOR. NEVER DRIVE WITH ANY LOCK, KNOB OR RACK IN AN OPEN OR UNLOCKED POSITION. ALL LONG LOADS SUCH AS, BUT NOT LIMITED TO, SAILBOARDS, SURFBOARDS, KAYAKS, CANOES, AND LUMBER MUST BE TIED DOWN FRONT AND REAR TO THE BUMPERS OR TOW HOOKS OF THE VEHICLE.

-ALL LOCKS MUST BE TURNED AND MOVED PERIODICALLY TO ENSURE SMOOTH OPERATION. USE GRAPHITE OR DRY LUBRICANT TO HELP THIS. LEITNER DESIGNS LOCKS ARE DESIGNED TO DETER VANDALISM AND THEFT BUT SHOULD NOT BE CONSIDERED THEFT PROOF. REMOVE VALUABLE GEAR IF YOUR VEHICLE IS UNATTENDED FOR AN EXTENDED PERIOD. PLACE AT LEAST ONE KEY IN THE GLOVE COMPARTMENT.

-FOR SAFETY TO YOUR VEHICLE AND RACK SYSTEM, OBEY ALL POSTED SPEED LIMITS AND TRAFFIC CAUTIONS. ADAPT YOUR SPEED TO THE CONDITIONS OF THE ROAD AND THE LOAD BEING CARRIED.

-DO NOT USE LEITNER DESIGNS LOAD CARRIERS AND ACCESSORIES FOR PURPOSES OTHER THAN THOSE FOR WHICH THEY WERE DESIGNED. DO NOT EXCEED THEIR CARRYING CAPACITY. FAILURE TO FOLLOW THESE GUIDELINES OR THE PRODUCT'S INSTRUCTIONS WILL VOID THE WARRANTY.

# WARRANTY

LEITNER DESIGNS WARRANTS PRODUCT TO BE FREE FROM DEFECTS IN MATERIAL AND WORKMANSHIP, FOR TERMS SPECIFIED BELOW, PROVIDED THERE HAS BEEN NORMAL USE AND PROPER MAINTENANCE. ALL REMEDIES UNDER THIS WARRANTY ARE LIMITED TO THE REPAIR OR REPLACEMENT OF ANY ITEM FOUND BY THE FACTORY TO BE DEFECTIVE WITHIN THE TIME PERIOD SPECIFIED. IF YOU HAVE A WARRANTY CLAIM, FIRST YOU MUST CALL OUR FACTORY AT THE NUMBER BELOW FOR INSTRUCTIONS. YOU MUST RETAIN PROOF OF PURCHASE AND SUBMIT A COPY WITH ANY ITEMS RETURNED FOR WARRANTY WORK. UPON COMPLETION OF WARRANTY WORK, IF ANY, WE WILL RETURN THE REPAIRED OR REPLACED ITEM OR ITEMS TO YOU FREIGHT PREPAID. DAMAGE TO OUR PRODUCTS CAUSED BY ACCIDENTS, FIRE, VANDALISM, NEGLIGENCE, MIS-INSTALLATION, MISUSE, ACTS OF GOD, OR BY DEFECTIVE PARTS NOT MANUFACTURED BY US, IS NOT COVERED UNDER THIS WARRANTY.

THE WARRANTY TIME PERIOD IS AS FOLLOWS: (2) TWO YEARS FROM DATE OF PURCHASE.

**HIGH SPEED OFF ROAD DRIVING EVEN WITH A LIGHT LOAD CAN CAUSE DAMAGE TO THE RACK, ACCESSORIES AND VEHICLE BODY. DAMAGE CAUSED BY HIGH SPEED OFF ROAD DRIVING AND ABUSE IS NOT COVERED UNDER WARRANTY.**

ANY IMPLIED WARRANTIES OF MERCHANTABILITY AND/OR FITNESS FOR A PARTICULAR PURPOSE CREATED HEREBY ARE LIMITED IN DURATION TO THE SAME DURATION AND SCOPE AS THE EXPRESS WRITTEN WARRANTY. OUR COMPANY SHALL NOT BE LIABLE FOR ANY INCIDENTAL OR CONSEQUENTIAL DAMAGE.

SOME STATES DO NOT ALLOW LIMITATIONS ON HOW LONG AN IMPLIED WARRANTY LASTS, OR THE EXCLUSION OR LIMITATION OF INCIDENTAL OR CONSEQUENTIAL DAMAGES, SO THE ABOVE LIMITATIONS OR EXCLUSIONS MAY NOT APPLY TO YOU. THIS WARRANTY GIVES YOU SPECIFIC LEGAL RIGHTS, AND YOU MAY ALSO HAVE OTHER RIGHTS THAT VARY FROM STATE TO STATE.

FOR WARRANTY ISSUES WITH THIS PRODUCT PLEASE CALL LEITNER DESIGNS CUSTOMER SERVICE **949-395-3049** OR EMAIL US AT **[SALES@LEITNERDESIGNS.COM](mailto:SALES@LEITNERDESIGNS.COM)**