

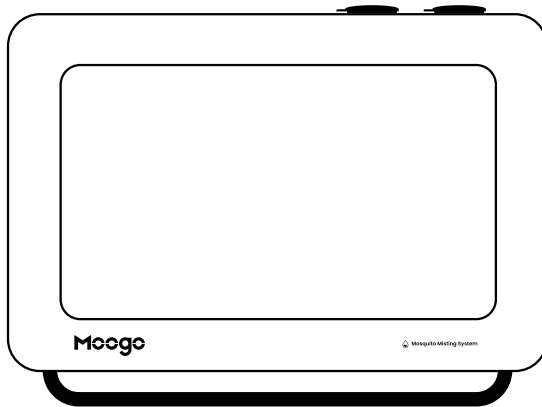

Smart Mosquito Misting System User Manual



Installation Videos
moogo.com/pages/installation

S1

CONTENTS

Important Safety Instructions	01
Notes for the Cord	03
Product Specifications & Packing List	04
Installation	05
APP Quickstart	08
Quickstart via Device	12
Device Functions	14
Taking Care of Your Moogo	18
Troubleshooting	20
Product Warranty	21
Customer Service	22



Important Safety Instructions

- Please read all instructions before using Moogo for the first time.
- Keep all electrical components (plug, cords) away from liquids to prevent electrical shock.
- Close supervision is necessary when using Moogo near children.
- Do not activate this system near people, pets, or food. Direct nozzles towards the targeted area, but away from food, cooking areas, and bodies of water including swimming pools & ponds.
- Concentrates may cause phototoxicity (burns) in certain plants.
- Follow instructions on chemical labels, and do not use Concentrates that are marked as "not compatible with outdoor misting systems."
- Unplug the unit when not in use, before cleaning, adding or removing parts, and when cleaning.
- When emptying the Moogo device, ensure that Moogo is turned off and unplugged.
- Do not operate Moogo if the cord or plug is damaged. Similarly, do not operate if Moogo malfunctions or is dropped or damaged.
- Please contact our support team for examination or repair.
- Do not use any attachments not recommended or sold by Moogo as these could damage the device.
- Moogo is intended for outdoor use only.
- Do not let the cord hang or touch hot surfaces.
- Keep the unit out of direct sunlight and away from any appliances which produce heat.

- Always connect the cord to your Moogo device before plugging into a wall outlet. To disconnect, turn off Moogo and remove the plug from the outlet.
- Make sure your Moogo device is on a flat surface during operation, or if it is wall mounted, that the device is level.
- When Moogo is not in use, ensure the glass panel remains closed.
- Do not use Moogo for anything other than its intended use.
- Do not alter or adapt Moogo in any way.
- Do not submerge the device in water.



Notes for the Cord:

- a) A short power-supply cord is provided to reduce risks resulting from entanglement or tripping.
- b) Extension cords can be used with extra care (purchased separately.)
- c) If an extension cord is used:
 - 1) The electrical rating of the extension cord should be at least equal to the electrical rating of the appliance.
 - 2) The extension cord should be a grounding type 3-wire cord.
 - 3) The longer cord should be arranged so that it will not drape over countertops or tabletops where it can be tripped over, snagged, or pulled on unintentionally (especially by children).

***PLEASE SAVE THESE INSTRUCTIONS**

WARNING: IF CONNECTING TO A PORTABLE WATER SYSTEM, THE SYSTEM SHALL BE PROTECTED AGAINST BACKFLOW

AVERTISSEMENT: SI L'APPAREIL EST RACCORDÉ À UN RÉSEAU D'EAU POTABLE, IL DOIT ÊTRE PROTÉGÉ CONTRE LES REFOULEMENTS

This device contains licence-exempt transmitter(s)/receiver(s) that comply with Innovation, Science and Economic Development Canada's licence-exempt RSS(s). Operation is subject to the following two conditions:

- (1) This device may not cause interference.
- (2) This device must accept any interference, including interference that may cause undesired operation of the device.

L'émetteur/recepteur exempt de licence contenu dans le present appareil est conforme aux CNRd'Innovation, Sciences et Developpement economique Canada applicables aux appareils radioexempts de licence. L'exploitation est autorisee aux deux conditions suivantes:

- (1) L'appareil ne doit pas produire de brouillage;
- (2) L'appareil doit accepter tout brouillage radioelectrique subi, meme si le brouillage est susceptible d'en compromettre le fonctionnement.



Product Specifications

Model No: S1

Product Name: Smart Mosquito Misting System

Rated Voltage: 120 Vac

Rated Power: 650 W

Voltage Frequency: 60 Hz

Product Size: 21 x 10 x 16 inches

Water Tank Capacity: 3 L/0.8 Gal

Packaging Size Per Unit: 23 x 13 x 18 inches

Net Weight: 46 lbs



Packing List

Device

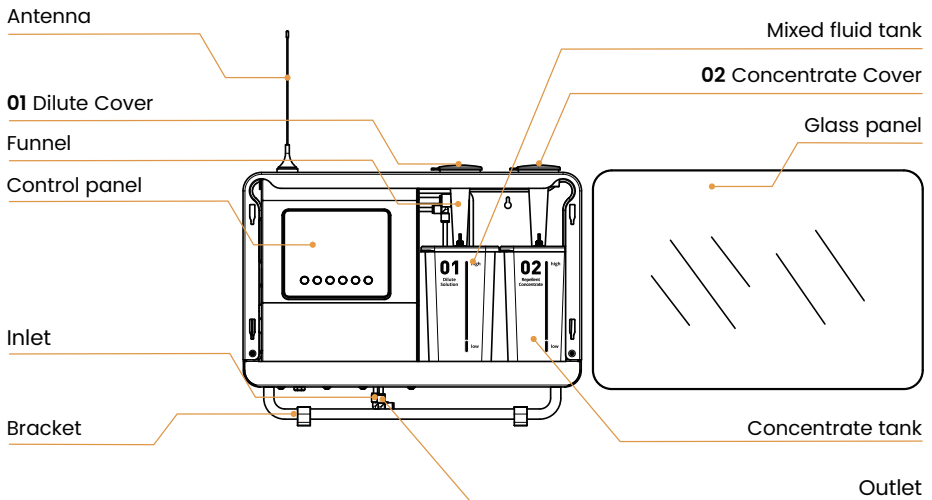

Mister Device Accessories

Plastic anchor	Concrete screw positioning card	Concrete screw	Standard silicone pad	Thick silicone pad	1/4" x 3/4" Hose Bib Adapter	1/4" Metal plug
QTY: 2	QTY: 1	QTY: 2	QTY: 2	QTY: 2	QTY: 1	QTY: 1



Installation

- 1 Please follow the below steps to install the device, or watch the installation video for reference. To ensure operational efficiency, it is recommended to be attached no more than 60 nozzles for the whole misting system, with a suggested installation distance of 8-10ft for each nozzle.



- 2 Use the concrete screw positioning card to mark areas for drilling holes on walls you have selected. When marking, ensure that the card is parallel with the ground.

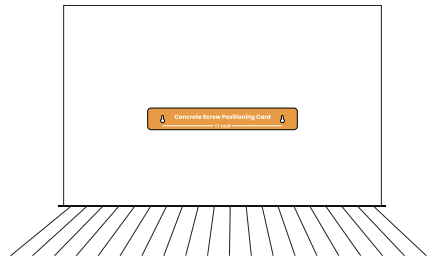

- 3 Drill into the marks you made on the wall, and insert the plastic anchor and concrete screw in succession.

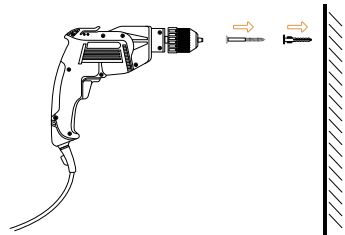

-
- 4** To reduce shock and protect your walls, attach four silicone pads to the back panel of the device. Place two standard silicone pads side by side on top, and two thick silicone pads side by side on the bottom.

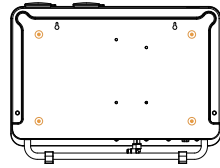

-
- 5** Align the holes on the back of the device with the nail and hang the device in an appropriate position on the wall.

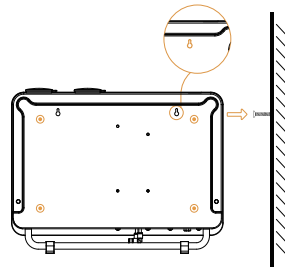

-
- 6** Connect the 3/4" hose bib adapte to the spigot, and connect the inlet pipe to the inlets of your device.

Note: Before connecting the inlet pipe to the inlets, **open the spigot to release air from the water inlet pipe**, before connecting it to the inlets of the device.

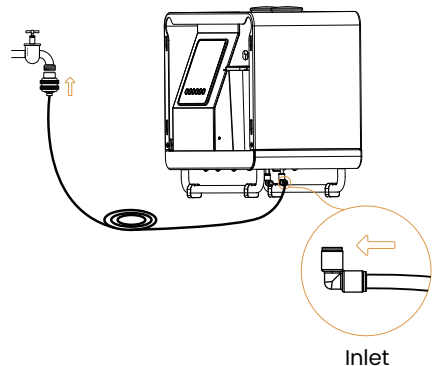

-
- 7** Connect the union tee outlet of the device to the misting nozzle at the water outlet's end. Plug the other outlet of the union tee with a metal plug when it is not in use.

Note: Make sure you hear a clicking sound when the water tube is connected to the nozzle, union tee, straight-through, etc. Additionally, ensure that the tube is fixed and cannot be pulled out directly. This indicates that it is connected to the device successfully.

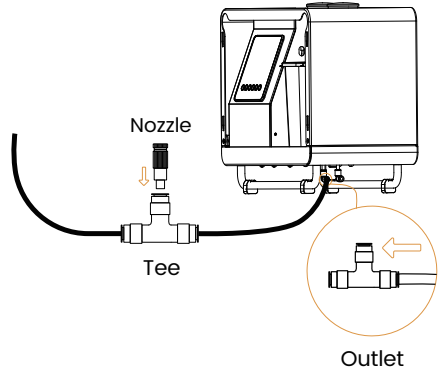

-
- 8** This device comes with both app and offline mode. After **turning on power**, you may operate the system via either mode. Once device setup is complete, ensure the glass panel is properly installed so as to keep the internal parts clean.

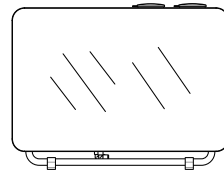



APP Quickstart

1. Downloading the App

Scan the QR code below and follow the prompts to install the app.



2. Registering for the App

When using the app for the first time, you need to register. Click "Sign up" to go to the registration page. Enter your email address, verification code, and set a password to complete the registration.

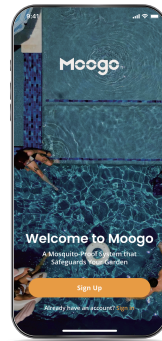

3. Log in to the App

Enter your email and password, and click "Sign In" to log into the app. If you forgot your password, click "Forgot password", and follow the prompts on the user interface to reset your password.

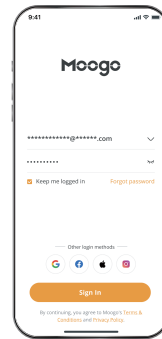

4. Adding Devices to the App

- Click "Add Device" in the upper right corner of the app.
- Enable Bluetooth permission on your phone, and place the phone close to the device.
- Start a Bluetooth scan on your phone to search for nearby devices.
- Select Wi-Fi and enter password to connect the device to Wi-Fi.

The specific steps are as follows:

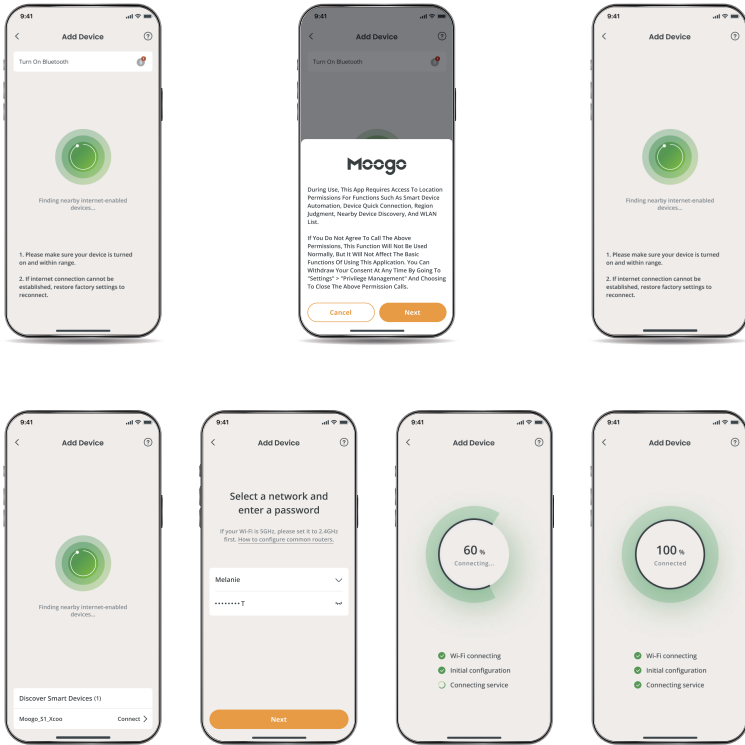

5. Self-Test

When using for the first time, please follow the steps prompted by the App to enter the self-test spray mode. If there is any abnormality during spraying, the App will provide a testing exception prompt. The self-test mode will pop up after you add a device in the App, or you can refer to the bottom of the screen to find the self-test interface. You can refer to the prompt to confirm on the device, or contact customer service for assistance.

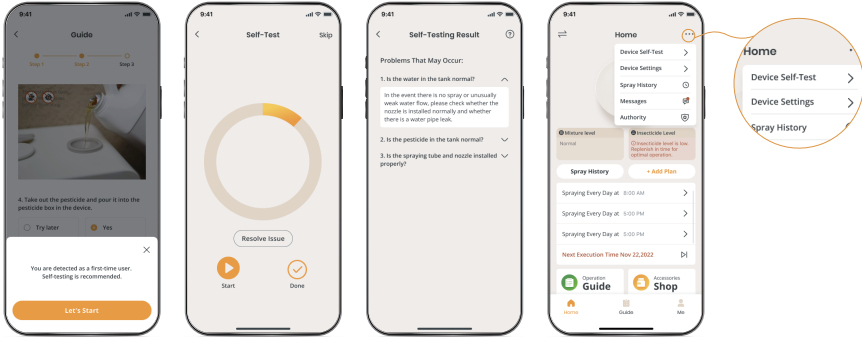

Note: Please ensure that the in tank #2 is filled above the low water level line.

6. To Add a Spraying Plan in the App

Click "Add plan" to open a pop-up window. In this window, you can select from multiple spraying plan modes provided by the device. After selecting, click "Confirm". The app also supports personalized spraying plans. Click "Customize" to open a pop-up window and set the spraying time, frequency, and duration according to the prompts on the page.

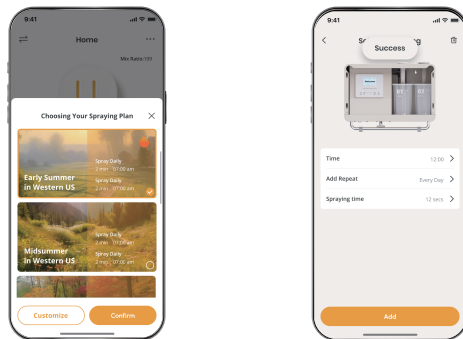

7. FAQs

If you encounter any problems during the use or setup process of the device, you can click "Guide" in the menu bar at the bottom of the main page to enter the FAQs page and search for related issues and solutions.

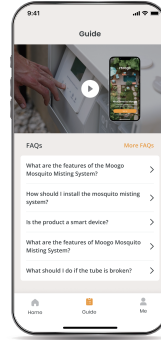



Quickstart via Device

- 1 After confirming your misting system settings, add concentrate into the 02 concentrate tank, and ensure it is filled above the low water level line.

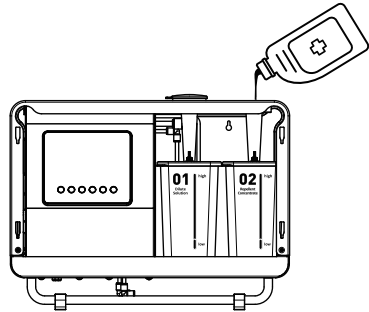

- 2 Press the MENU button to turn on the device. The screen will display "Pair Device" to enter pairing mode. Select "Cancel" to jump out from the "Pair Device". And then enter the time setting page.

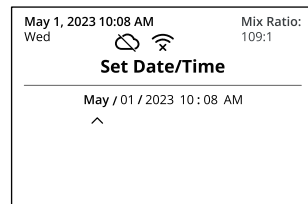

- 3 After time setting is complete, it will jump to the "Choose Concentrate" page.

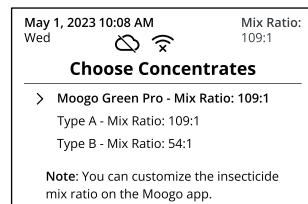

- 4** After completing the startup settings, the device is ready to be used. It is recommended to activate self-test when using for the first time to test the functions of the device and confirm it can extract concentrates normally, and there are no abnormalities or leakage in the inlet and spray. Just squeeze the trigger to start spraying, and squeeze again to stop. Allow nozzles to spray for about 1 minute to test.

During this process, it is recommended to reserve 2-3 nozzles in the system without installation, so as to remove possible impurities in the pipeline.



- 5** After the test is completed and there are no abnormalities, install the glass panel on the device and start living mosquito-free!

***For more detailed information, please refer to the following instructions.**



Device Functions

The device panel is displayed as below:

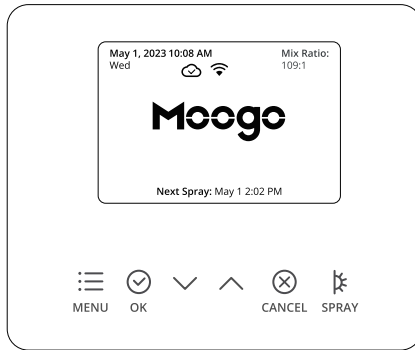

- **MENU:** Function button, touch once to enter function selection, touch twice to return to the main interface;
- **OK:** Confirm current settings;
- **^:** Increase/raise;
- **v:** Decrease/lower;
- **CANCEL:** Cancel spraying;
- **SPRAY:** Spray manual button, click to start spraying. If the device is already spraying, click again to stop spraying;
- The screen displays the date/time/week/WIFI status/mix ratio, as well as the next scheduled spraying time.

1. Power on the device and press the menu button, the screen will light up. After startup is complete, the main interface is displayed.



2. Menu

Click the "MENU" button to enter the function selection menu. Click "^" or "v" to select the desired function, click "OK" to enter the settings, and click "Cancel" to return to the previous menu.

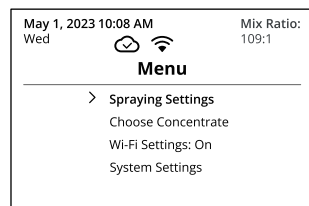

3. Spray Settings

Select the "spraying settings" option, click the "OK" button to enter the settings (functions include: spray schedule – spray duration setting); click "∧" or "∨" to select the desired function, click "OK" to enter the settings, and click "Cancel" to return to the previous menu.



Select the "spraying schedule" option. Select "Add Schedule" to add a new spraying schedule. Choose the "Time" field to enter the time setting. Click "∧" or "∨" to select the day(s) of the week for fixed weekly spraying times, and then click "OK" to confirm. Select "Save Schedule", and the spraying schedule will be generated.

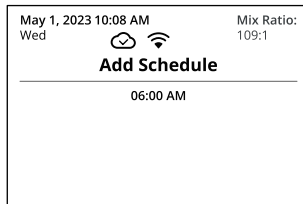
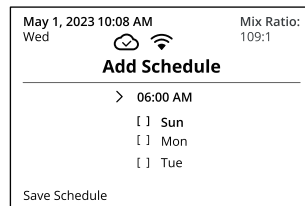
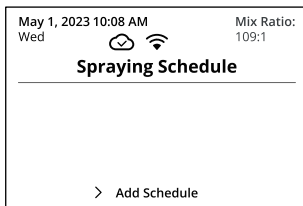

Select the "Spraying Duration" option to enter the spraying duration setting. The default spraying duration is 60 seconds. Click "∧" or "∨" to select the desired duration, click "OK" to enter the settings, and click "Cancel" to return to the previous menu.

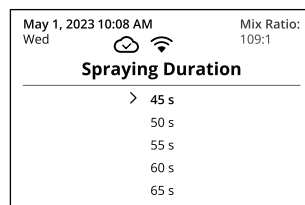

4. Concentrate Type

Select the "Concentrate Type" option, click " \wedge " or " \vee " to select the desired concentrate.

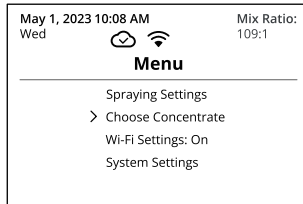

5. Wi-Fi Setting

Select the "Wi-Fi Settings" option, and click "OK" to turn on or off Wi-Fi. The status of Wi-Fi connection can be seen from the WIFI icon on the interface.

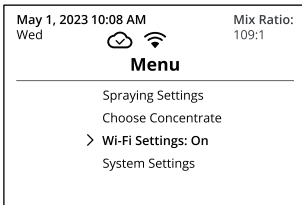

6. System Settings

Click "OK" to enter the settings. Click " \wedge " or " \vee " to select the desired option.

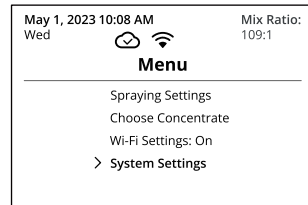

7. Date/Time settings

Select the "Date/Time" option, and click "OK" to enter the settings. Click " \wedge " or " \vee " to select the desired setting (format: month-day-year/hour:minute:second/week); Click "OK" again, and the current value will flash. Use " \wedge " or " \vee " to adjust the value, and click "OK" to confirm the setting.

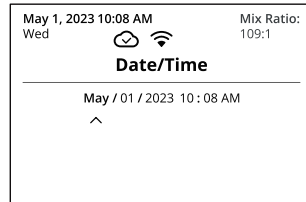
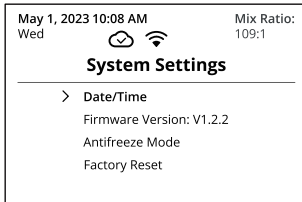

8. Firmware Version

Select the "Software Version" option, and click "OK" to display the software version on the interface.

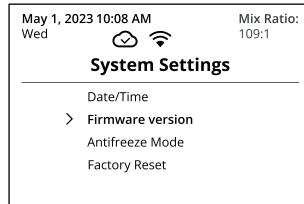

9. Antifreeze Mode

Select the "Antifreeze Mode" option to enter the setup page. First, ensure that antifreeze has been added to the water tank. Click "OK", and the antifreeze will fill the device's pipes. Click "Cancel" to stop.

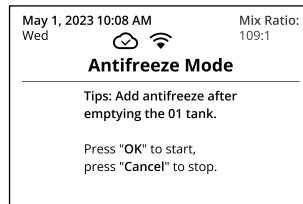
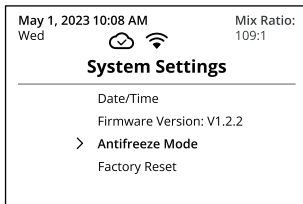

10. Factory Reset

Select the "Factory Reset" option, and click "OK" to enter the settings. The screen will display operation instructions. Click "OK" to restore the device to its factory default settings, or click "Cancel" to return to the previous menu.

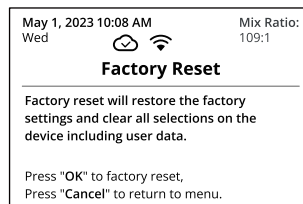
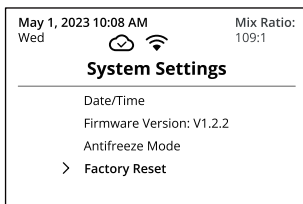



Taking Care of Your Moogo

● Cleaning your Moogo

To maintain and upkeep your Moogo, it is important to keep it clean. We recommend cleaning the exterior of your device once a month or as frequently as when you add or change concentrates. To ensure optimal performance, keep your Moogo flat and level, and avoid exposing it to direct sunlight or high temperatures. Make sure to unplug your Moogo before cleaning. To clean the exterior of the device, simply wipe it with a damp dishcloth. If it is particularly dirty, add a small amount of detergent when cleaning and use a dry cloth to remove excess moisture. Do not submerge your device in water because it contains electrical components that could be damaged by excess water and may cause electric shock.

● Use the Antifreeze Mode to Prevent Pipes from Freezing

To prevent the pipes of your Moogo device from freezing in winter, follow the below steps to empty the O1 and O2, proceed to fill up tank O1 with antifreeze before the onset of winter, and spray once. It is recommended to store Moogo indoors during winter.

1. Unplug the power cord and empty the tanks.

a. To empty out the tanks, you can use an extra water pump to pump out the liquid from tanks O1 and O2. Or, uninstall the device as shown below, by removing the two screws in the front and taking out the upper cover from the top.

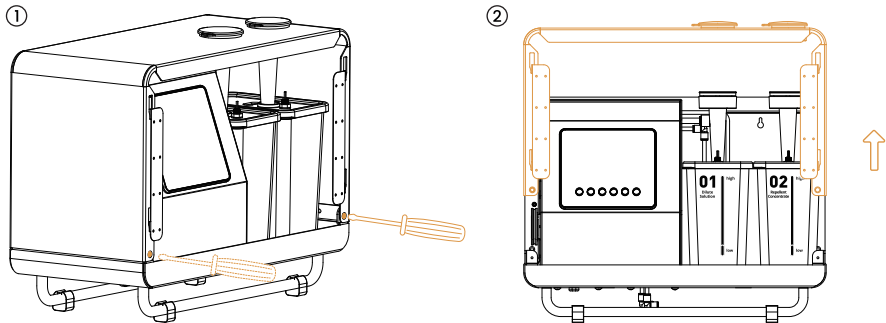

b. Open the lids and empty tanks O1 and O2.

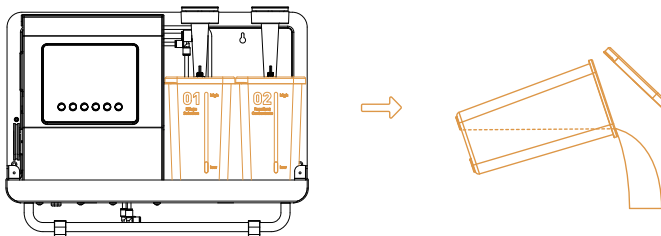

2. Reinstall the top cover of the device. Then fill tank 01 with antifreeze up to a high level.

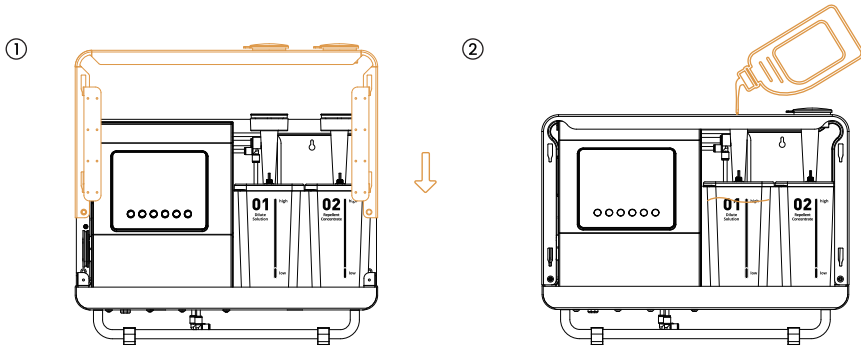

3. After reinstalling the device, plug in the power cord, go into the Antifreeze Mode on the display screen, select Antifreeze Mode and press “OK” to start. After antifreeze is sprayed out, press “Cancel” to stop. Now, your water pipes are protected with antifreeze from freezing.



4. It is recommended to uninstall and store your Moogo device indoors during winter months.

Notes: This equipment complies with FCC's and IC's RF radiation exposure limits set forth for an uncontrolled environment. The antenna(s) used for this transmitter must be installed and operated to provide a separation distance of at least 20cm from all persons and must not be collocated or operating in conjunction with any other antenna or transmitter. Installers must ensure that 20cm separation distance will be maintained between the device (excluding its handset) and users.

Cet appareil est conforme aux limites d'exposition au rayonnement RF stipulées par la FCC et l'IC pour une utilisation dans un environnement non contrôlé. Les antennes utilisées pour cet émetteur doivent être installées et doivent fonctionner à au moins 20cm de distance des utilisateurs et ne doivent pas être placées près d'autres antennes ou émetteurs ou fonctionner avec ceux-ci. Les installateurs doivent s'assurer qu'une distance de 20cm sépare l'appareil (à l'exception du combiné) des utilisateurs.



Troubleshooting

If your device experiences an abnormal issue that cannot be resolved, please contact hello@moogo.com for assistance.

- **Device is not spraying**

1. Check the power socket.
2. Check if the water tap is turned on.

- **Device is making loud sounds**

Check if there are any loose parts around the pump and motor.

- **Some nozzles are not spraying or misting is weak**

1. If the adjacent nozzle is spraying normally, please replace the clogged nozzle.
2. If the nozzle is spraying weakly or if the nozzle closest to the machine is spraying but the nozzles further away from the machine are not, please check for leaks in the water pipes.

- **Cannot connect the App to the device**

Check if the device's Wi-Fi is turned on.

- **There are still mosquitoes or insects found after using Moogo**

1. Check if the device is running out of concentrate. If so, refill the water tank.
2. Make sure the device is placed correctly in the area where mosquitoes or insects are present.
3. Increase the spraying frequency or duration as needed.
4. Use additional methods such as mosquito nets or repellents to supplement the use of Moogo.
5. Change the mix ratio selected.

***For more FAQs, refer to the "FAQs" page in the Moogo App.**

NOTE: This equipment has been tested and found to comply with the limits for a Class B digital device, pursuant to Part 15 of the FCC Rules. These limits are designed to provide reasonable protection against harmful interference in a residential installation. This equipment generates uses and can radiate radio frequency energy and, if not installed and used in accordance with the instructions, may cause harmful interference to radio communications.

However, there is no guarantee that interference will not occur in a particular installation. If this equipment does cause harmful interference to radio or television reception, which can be determined by turning the equipment off and on, the user is encouraged to try to correct the interference by one or more of the following measures:

- Reorient or relocate the receiving antenna.
- Increase the separation between the equipment and receiver.
- Connect the equipment into an outlet on a circuit different from that to which the receiver is connected.
- Consult the dealer or an experienced radio/TV technician for help.

This equipment complies with FCC radiation exposure limits set forth for an uncontrolled environment. This equipment should be installed and operated with a minimum distance of 20cm between the radiator & your body. This transmitter must not be co-located or operating in conjunction with any other antenna or transmitter.



Product Warranty

Product warranty period: 3 years

Product Name	Smart Mosquito Misting System
Model	S1
SN code	
Purchase address	
Purchase date	M D Y
Customer name	
Contact address	

Service Guide:

- The quality of this product is guaranteed in accordance with the contents of the quality assurance certificate.
- Customer service for this product is based on the purchase date, so please fill in the purchase date correctly. (For cases where the purchase date cannot be confirmed, the free customer service period for the product will be six months from the manufacturing date.)
- This product is for household use only. For use outside its scope (industrial use, non-household use), the free customer services period is six months.
- Customer service is provided by **Moogo.com**.
- The quality assurance certificate for this product cannot be reissued if lost, so please keep it safe.

*If non-Moogo technical personnel perform repairs, modifications, or use non-Moogo components on the product without our company's permission, may void the product warranty.



Customer Service

- **Quality Assurance**

The quality assurance for this product is attached to the product manual.

Please read the certificate carefully and keep it safe in the packaging box.

The product quality guarantee period is 3 years from the date of purchase (excluding non-household use).

- **Requesting repairs**

Moogo's customer service email is: **hello@moogo.com**. Our customer service hotline is:

(866) 646-1230. Before requesting for customer service, please refer to the user manual to confirm the underlying issue. If the problem cannot be resolved, please disconnect power and stop using the device before contacting customer service.

- **For products within the warranty period**

Carefully record the product name, model, SN code, purchase date, fault status, address, name, phone number, etc., and then contact customer service.

- **For products beyond the warranty period**

Repairs will be offered based on the fault status for products beyond the warranty period.

Moogo



Installation Videos
moogo.com/pages/installation