

Vibratory Feeding Systems

Maintaining Vibratory Systems

Trouble shooting guide on maintaining vibratory equipment.

Moorfeed



A Division of EAS

Table of Contents

DETERMINE THE PROBLEM	1
WHEN DOES THE PROBLEM OCCUR?	2
OBSERVE THE SYSTEM RUNNING	3
LOOK FOR BROKEN SPRINGS	4
PREVENTIVE MAINTENANCE	5
LISTEN TO THE SYSTEM	6
TOUCH THE SYSTEM	7
INSPECT THE ELECTRICAL COMPONENTS	8
SOLID STATE CONTROLLER	9
INSPECT THE SENSOR	10
SENSORS	11
UNDERSTANDING YOUR FINDING	12
SENSOR/RATE PROBLEM	13
NEW INSTALLATION	13
EXSITING INSTALLATION	14
JAMS	14
TUNING	15
RESONANCE TUNING	16 - 17
MECHANICAL TUNING	18
MOUNTING FEET	19
AIR GAP	20
CHECKING THE TUNING	21 - 22
SPRINGS	23
MAZZA’S RULE	24
NEMA ENCLOSURES	25
TUNING 101	27 - 31
NOTES:	32 - 34

This information is intended to give the end user a working knowledge and understanding of the expected performance of a vibratory feeder bowl and its related components. To give the user a complete education is beyond the range of this text. It is, however, intended to make known and to make clear any terms of procedures that may otherwise be unspecified or unfamiliar.

In the occasion conditions occurs with the feeding system that is unusual or conflicting with normal operation, please attempt to use this information as a guide to trouble shoot and repair the system. If there is a situations that cannot be corrected then you will need to contact a trained technician.

Determine the problem

Talk to the operators

What is the problem?

Ask the machine operators to tell you what they see as the problem. The operators may not know the exact nature of the problem, but will have observed what happens. Often their insight will guide you to the real problem.



Bowl, track, control & stand

What happens when the problem occurs?

Sometimes a few questions will help the operators to focus on the feeder problems. Does the feed system run at all? Does the hopper cycle properly; come on only when the bowl is running and not feed parts so fast that it over-fills the bowl? Does the bowl feed slower when filled or run too fast when empty? Is there an apparent jam? Do parts spill out of the bowl? Is there a hammering sound? Do good parts fall off the track? Do un-oriented parts feed through to the machine or jam in the track or bowl? Are the parts to specification? Is there flash on the parts? Has the track become slick from mold release or oil? Is the track blocked with dirt, flash, chips or other debris? If the system quit running, did it happen gradually, or all at once?

When the problem does occur?

Another machine starting up may occasion a drop in line voltage. A reduction or increase in air line pressure can effect orientation on bowls using air jets. A heavy machine cycling in the area may be transferring vibration through the floor that affects the system and goes away when the machine shuts down. A second vibratory feeder running on a common table could set up a harmonic node that would affect the performance of the first feeder.

How does the operator fix the problem?

Get the operator to describe what they have to do to fix the problem or work around it. A jam that occurs in the same location and is readily cleared by removing the jammed part would warrant looking at the parts and the tooling at that location. Jams that require unbolting sections to clear the jam point toward a slightly more difficult problem. If the operator has to remove the jam and clear a large section of track, the problem may be caused by a section of the bowl that “closes” or becomes more confined. A single out of tolerance part could also cause it.

An operator may need to hand place oriented parts in the track to keep up. He or she may have “helped” the parts down the track by pushing them by hand.

Clearing jams with picks, pliers, screwdrivers or metal objects will damage the tooling and cause additional problems. It is better to provide the operators with brass or plastic tools to use to clear jams.

Observe the system running

Look for parts flow

Turn on the feed system and watch it run for a minute or two. You are looking to see that the parts feed consistently up the track. Also check to see that the parts flow at the same rate and the volume up the internal helix in the bowl and that there are no dead spots or areas in the bowl.

Watch the parts feeding through the external tooling. Do the parts negotiate the tooling cleanly and at an even rate?

Look for obstructions

Make sure vibrating drive bases, bowls, track and hopper pans are not touching any mounts, brackets, or other items on the mounting plate or table.

Check to see that vibrating units are clear of the sound enclosure and the sound damping material.

If the parts are jamming in the tooling or falling off the track, check to see that the tooling is free of dirt and/or scrap or foreign parts, and if it is jamming between the tracks check the underside of the track directly above the jam for weld spatter or other snags. Also check to see that the pitch between the tracks is constant and not closing.

Look for interference

Parts spilled out of bowl may be dampening the drive if they are wedged between the drive and a fixed object such as the sound enclosure, spring banks, and under the drive unit.

Another place to look for interference could be misalignment between the bowl discharge and the inline track or other means of conveyance. Parts hesitation or wedging as they convey across this gap can be the source of the jams and cause the low rates.

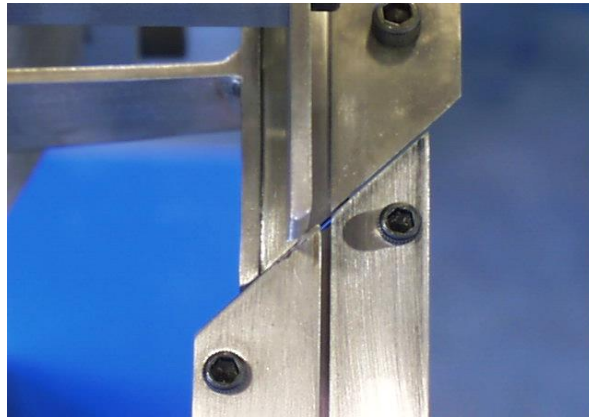

Bias Angle transfer

Adjustable tooling normally should open slightly in the direction of flow. Tooling that is wider or higher when the parts enter than when they leave will wedge or cam lock the parts.

Parts feeding through the discharge and other areas with overhead confinement should have the confinement adjusted close enough to keep the parts edge from overlapping. However, if the confinement is so close that the parts under normal vibration hit the overhead confinement, flow through the confined area will be impeded.

The coil gap on the feeder is directly proportional to the bowl/inline gap.

Look for broken springs

Check the banks of springs for broken springs. Most springs break in the area just beyond where they are clamped, just above the spacer on the lower clamp and just below the spacers on the upper clamps. Look for a crack line on the outer edges. Another indicator of cracked or broken springs is red or orange dust sometime encircling the base on the drive.

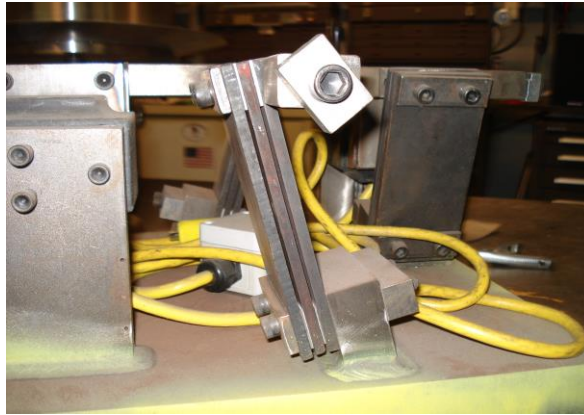

Spring bank

Preventive Maintenance

Overhaul the unit

If you have an opportunity to overhaul the unit, remove the spring's one bank at a time, it is important to remove only one bank at a time as the other banks will maintain the proper position insuring that you maintain the dimensional targets, check for cracks springs by holding one end of the spring and rapping the other end on a metal plate. Then check the other end. If the spring is cracked, it will break or sound dull. Be sure to clean all rust and oil from the clamped areas of the springs and to clean the spacer as well. Replace broken springs with spring of the same size and material. If you don't have a spring of the same thickness, you can use several thinner springs. See *Mazza's Rule of the Square of the Numerators* to estimate the required number of thinner springs to use.

Look for Broken welds

Check the bowl welds for cracks and broken welds. Look for welded tooling that is vibrating out of sync with the rest of the bowl. In coated bowls, after a period of time the coating will sometimes crack over a broken weld. Look for red or orange dust.

Look for solid contact

All the feet on the stand, base or table should be in solid contact with the floor. If you suspect the feet are not solid, take a wrench and check them. The vibrating drive should be firmly attached to the mounting plate. Check the rubber isolation mounts (feet) for deterioration of the rubber and check that the feet are securely bolted to the riser or the plate and to the vibrating drive. Then pry up slightly at each foot to see if the rubber to metal bond is secure. The bowl should be securely clamped by each toe clamp. Check the torque on the toe clamps using a torque wrench. Bolts on a drive unit should be torque to the bolt recommend specification. Larger bowl will have a bolt in the center of the bowl, this bolt needs to be tight was well make sure the center bowl has the proper spacer between the drive and the bowl bottom, failure to do this will cause the dome in the bowl bottom to invert.

Listen to the system

Listen for metal to metal hammering

Hammering means the vibrating components are striking one another or striking something around the system. Check the bowl and the track interference and the track to machine interface. If the hammering comes and goes that is a good indication that a part or scrap is getting into the gap and causing the hammering. Reposition the drive to open the gap if there is interface interference between the bowl and discharge and the external track. Move the object being struck if it is something around the system. Close the interface gap if the hammering is caused by parts edges getting into the gap.

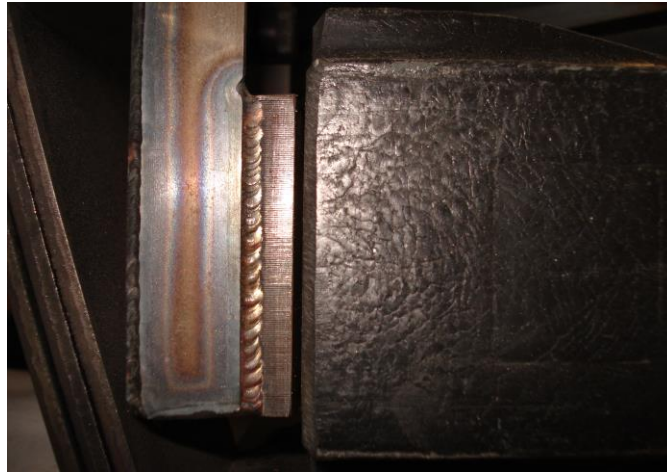

Coil gap

Check the coil/armature interface. To check for hammering, insert a piece of paper between the pole faces. Marks on the paper indicate the gap is too close. Reset the air gap being careful that the pole faces are parallel. The air gap should be as close as possible without hammering.

Listen for hunting

Hunting is when the volume or tune of the vibrations seems to be rising and falling cyclically. *Hunting* indicates the feeder is under tuned or at resonance.

Listen for a discord tone

A discord tone is a steady vibration sound that wanders off. It can be higher or lower in a pitch than the feeder tone. A discord is a signal of noise or a harmonic; something is flapping out of sync with the rest of the feeder.

Touch the System

Touch the bowl

Feel for areas vibrating out of sync with the rest of the bowl. Feel the welds in the area. A “pinching” of the fingertips is a good indicator of a broken weld that cannot be seen.

Occasionally, an area of tooling will appear to be bouncing parts excessively, and yet there are no broken welds. If wedging a piece of wood such as a hammer handle between the tooling and the wall or a brace helps, then the tooling probably needs to be braced or supported better. Excessive vibrations can be caused by other deficiencies such as a stand or table that is too light or not adequately rigid. Eliminate the other possibilities before welding additional braces.

Touch the mounting plate

Feel for excessive vibration being transmitted into plate from the feeder. If the whole plate seems to be vibrating, the plate is probably too thin.

Feel for areas on the plate that are vibrating out of sync with the rest of the plate. If the plate is flexing in one or two areas only, then the plate support needs to be strengthened in that area. Try wedging a 2 x 4 between the floor and the plate in the area of the tinning. If it corrects the problem, then reinforce the plate support or add a jackleg.

Touch the base, table or stand

Feel the legs for excessive vibration. Heavy wall square tubing is recommended for building vibratory feeder bases, table or stands. It is suggested that 2-1/2” tubes for feeders over 10” and 4” tubes for feeders over 21”. The higher the feed rate the more substantial the stand has to be. Cross bracing between the legs and support under the mounting plate is required for good performance.

Inspect the electrical components

Check the coils

On a single coil unit, if the coil is shorted or the connection is broken the feeder won't vibrate at all. If one coil on the multiple coil unit is out, the feeder will operate but have systems similar to tuning or other problems. Turn on the feeder, take a small screwdriver, paper clip, nail or other small iron or mild steel object and touch the object to the coil in the area of the coil armature interface, if the object is attracted to the coil it is working. Do not expect this to be a strong magnetic pull you normally get from an electromagnet. Most of the electromagnetic energy of the coil is going into the armature but will get a weak attraction if the coil is working.

The pole faces of the coil should be as close as possible to the armature without touching. Too close and hammering will occur. Pass a piece of paper between the pole face, if the paper comes out marked then the pole faces are hitting.

The paper marked in one area only is an indication that the pole face is not parallel. Reset the air gap to eliminate the hammering being sure to set the face parallel.

Check the controller

There are several types of controllers used on vibratory system, the two most common are variable and solid state control. Variable frequency controls are starting to become popular in the industry. When you have a critical feeding application that requires a close control or were spring fatigue, fluctuating voltage or load is causing problems an amplitude controller with a feedback transducer is available.

Variable transformer controller

A large amount of the current systems have either a variable transformer or a solid state control. A variable transformer controls the voltage output to the coil, since they are transformers, some are built to provide output voltage higher than higher that the line voltage. The variable transformer control is stable and normally has a good range. Problem occur when the winding wear thin and break or shorts.

Sometime the control will only work full on. This is often an indication of a break in the winding.

A variable transformer control can be rectified to run 60-cycle drive. The rectifier puts a heavy DC component into the transformer that will quickly saturate a normal sized variable transformer, therefore a 25 Amp transformer would typically be used to control a feeder that would draw 10 Amps if running AC or non-rectified. Because of the cost for the much larger transformers, most rectified or 60 cycles drive use solid state controls.

Solid state controller (phase shift)

Solid state controllers today typically come with an internal switch that permit them to run both 60 cycle (rectified, half wave or DC) and 120 cycle (non-rectified, full wave or AC) base drive units. The 60 cycle or 120 cycles refers to the number of vibrations per second. When installing a replacement solid state control make sure the internal switch to “A” for 120 cycle and “D” for 60 cycles. Thin springs 3/16” or less, and fiberglass springs are used on 60 cycle feeders.

One problem with Solid state controllers is that they sometimes are very sensitive to control. A small movement of the potentiometer produces a large change in amplitude in the feeder. Solid state controllers typically come with a min/max trim pots on the board to set minimum and maximum amplitude of the feeder and uses the potentiometer on the outside of the controller to control the amplitude of the feeder between the min and max range, thus giving the operator finer control. The minimum pot normally is set so that the parts just start to move when the external potentiometer is set to zero and the maximum is set to the highest amplitude desired or recommended when the external potentiometer is set at 100% the high setting should not cause the coils to hammer.

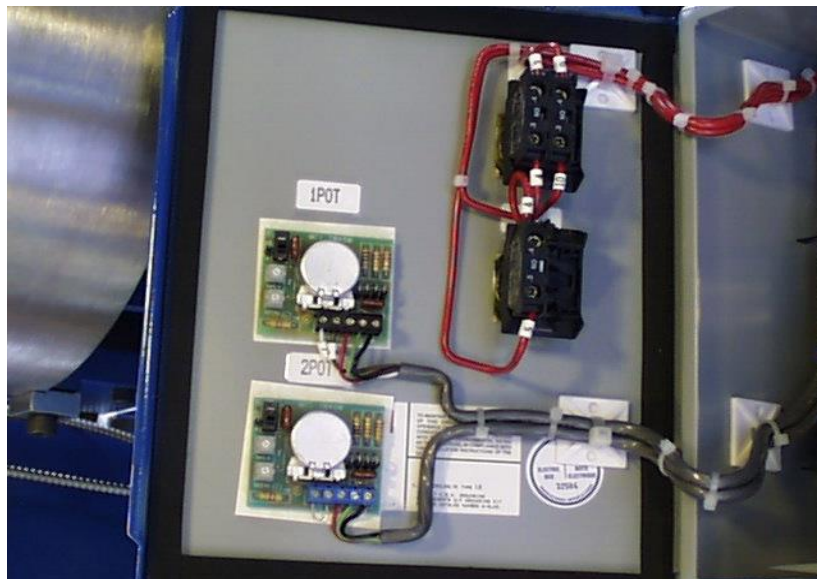

Solid State Controls

Inspect the sensors

The purpose of the Photo-Electric sensor is to turn the bowl on and off so as to maintain a full line of parts in the track and not allow the parts to back up into the bowl and jam or mis-orient parts. Sensors will either be controlled by a Programmable Logic Controller (PLC) or have a programmable logic card built into the module. When the feeder system is using a Photo-Electric sensor to monitor the gravity, conveyor or inline track and is not being control by a PLC, then it must be set or programmed for the application it is being used. The switch will very seldom operate correctly right out of the box.

The first step in setting the sensor is to mount the source and the receiver cables to a non-vibrating or moving bracket and position them so they are focused at each other. Apply power on the proper leads of the sensor. If the sensor does not trigger or function then turn the sensitivity up, or usually clockwise, until the sensor switches state or functions. Next move the part or target between the focused cables. The switch should now return to its default state. This is a light operate condition. If this does not occur then the beam is passing around or through the target. The sensitivity needs to be reduced and or some portion of the beam needs to be blocked.

Optional description:

Most sensors can be set to operate either “light” or “dark” operate. This means that if the light beam (when the switch is powered) is passing from the emitter cable to the receiver cable uninterrupted and the switch is functioned or triggered then this is a light operate condition. When the beam is interrupted the switch returns to its default or non-functioned state. The device that is being functioned inside the module is usually a set of contacts. These contacts are either normally opened “NO” or normally closed “NC”. In the “dark operate” mode the logic or state for the contacts are reversed as well as the on and off delay timers.

As the parts feed past the sensor, the “off delay” needs to be set so to allow time for a part to move into the beam and exit the beam without activating the sensor. This is attained by increasing the timer potentiometer. It is good practice to allow for the occasional slower part to be the standard rather than the faster moving part. Additional storage of the parts past the sensor can be created with this function.

Take care when adding time on this timer because if this timer has too much time, indiscriminately applied, the parts can back up into the bowl and cause problems. The next function that should be programmed is the “on delay”. This timer usually is set to allow for some of the stored parts in the track to exit before turning the bowl on immediately after the parts feed away from the blocking sensor. This timer can starve the track if too much time passes before turning the bowl back on.



Photo Sensor

A proximity sensor works similar to a photocell sensor.

The paddle switch or proximity sensor controlling the hopper should be set to maintain the proper level of parts in the bowl to ensure a good feed rate. The hopper sensor should be wired in series with the bowl so it will run only when the bowl is on. Otherwise, if the switch were to call for parts, just as the bowl turns off, the hopper would overload the bowl. The flow of the feeding parts ensures that a correctly set paddle or sensor will sense the parts level accurately.



Paddle switch

Understand your findings

Do no harm

If the feeder is still under warranty or if you are uncertain of the problem or the solution, call the manufacturer. Most manufacturers void warranty if someone other than their representative works on the equipment.

Items you control

However, make sure you have eliminated those under your control.

1. **Parts.** Are the parts the same and within tolerance? Are they made of the same material and as clean as the parts sent to the manufacturer for building the equipment?
2. **Installation.** Is the equipment installed correctly? Is the tooling adjusted correctly for the part?
3. **Power and air.** Is the system getting adequate power at the correct voltage and clean and dry air at the recommended pressure?

Items beyond your control

If it's under warranty and you have covered all your bases, then call the manufacture. Do not machine, grind or weld a feeder under warranty unless authorized to do so by the manufacturer.

Power on – No vibration

Electrical problem

The system has power but the feeder(s) is not running, turn the power off, check the fuse(s), check the power cord from the control to the coil(s) for a short or broken wire, check the line for continuity to the coil(s), check the coil(s) to see if it has been shorted out, repair any problems and turn the power back on.

Sensor problem

The system has power, the lines, fuses and the coils all check out, yet the vibratory bowl still won't come on. Suspect the sensor. Clean the photo optics and check there alignment. If the system still won't run check the sensitivity adjustment. Mark or note the adjustment prior to moving it so you can return to the setting if necessary. Check the switch for continuity.

- Repair or replace any defective components and turn on the unit.

If the sensor checks out the problem is probably in the relay. The relay may be either solid state or contact type. Replace the relay if necessary. On system with a PLC, if all else fails, check the program.

Rate problem

Feeder won't keep up

New Installation

Try tuning down the amplitude. The rheostat or potentiometer setting recommended by the manufacturer is not cast in stone. Sometimes slowing down the unit produces more through put of oriented parts.

Check out the system with the parts that were used to build the feed system. If these parts run at rate, look at your production parts. The parts may have been changed slightly in dimension or material composition. They may be from different suppliers, or the tolerances are at the high end where the samples used to build the bowl where at the low end. The forming tools used to make the parts may be wearing and now the parts have burrs or smears. Plastic parts may have mold release and metal parts more oil.

If necessary clean the bowl and the parts, or replace the parts, and check the rate again.

When buying a feed system, it is recommended that you supply parts from all vendors to the feeder company to build and test the feeder. Also supply a drawing with tolerances so there are no surprises.

If the original parts are used to build and test the bowl won't feed at rate, then it is probably the installation. Make sure the stand is solid to the floor and anchored if anchors are required. Make sure the floor itself is solid and not flexing. If the feeder is on your table, make sure the table is not flexing.

If necessary reinforce deficient areas.

Existing Installation

If the system has been moved, check the installation as detailed in new installations.

If the feed rate seems to fade over time and the operator has to keep increasing the power to the feeder, a spring may have broken or the springs may have worked hardened and change the tuning. If there are no broken springs, remove a spring or exchange at least one spring with a thinner one.

Jams

Jams in the bowl

If the jams are caused by bad or broken parts remove the part.

If the jams occur between the tracks inside the cowl in approximately the same area, check the underside of the upper track for weld spatter. File or grind these off. If there is no spatter then reduce the quantity of parts in the bottom of the bowl to one or two layers deep. If this does not resolve this issue there are other methods such as skirting the bowl or removing lining but normally needs to be done at the manufacturer facility.

If the jams occur in the tooling, check the jams to ensure it is within specification, if it is a good part, check to see the tooling doesn't close in the direction of flow. Reset adjustable tooling to open in the direction of flow or to be parallel from end to end when necessary.

Before you move or grind tooling to the bowl, be sure you confirm that the sensors are working as they should and that jams are not caused by back pressure in the bowl.

Tuning

Electrical Power

Vibratory feeders are tuned when the bowl and base resonate at or near the frequency of the power source. Electromagnetic coils are most often used to excite the tuned two mass system of the bowl and base, however, an air vibrator or another source of energy could be used as well. Electrical coils. Normally operate off a single phase of the power supply. The power supply frequency would normally operate off a single phase of the power supply. The power supply frequency would typically be 60 Hertz in the North America and 50 Hertz in Europe.

Straight AC or Rectified Current

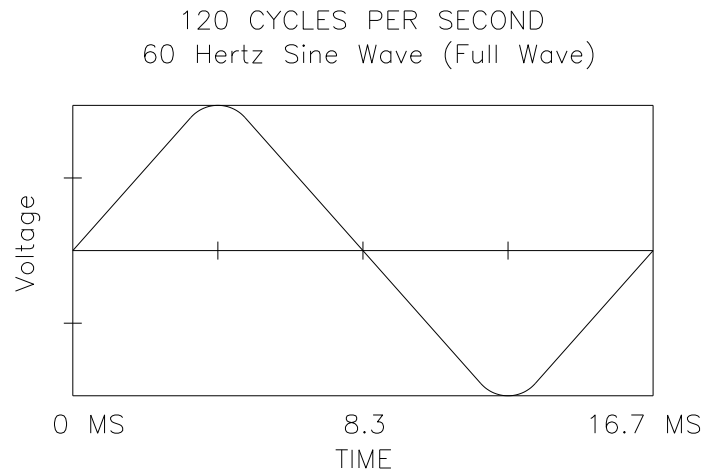

Feeders using a straight AC power supply operate at 7,200 vibrations per minute (VPM) on 60 Hertz current and at 6,000 VPM on 50 Hertz. At 60 Hertz the feeder coil receives a positive electrical impulse the first 8.33 milliseconds of the 16.66 milliseconds. Feeder amplitudes are $\frac{1}{2}$ that of rectified feeders of the same size, however, since the vibrations per minute are doubled many parts feed at the same rate. Orientation can be accomplished using “finer” features on the parts, due to the lower amplitude of the bowl.

60 CYCLES PER SECOND
60 Hertz Sine Wave (Half Wave)

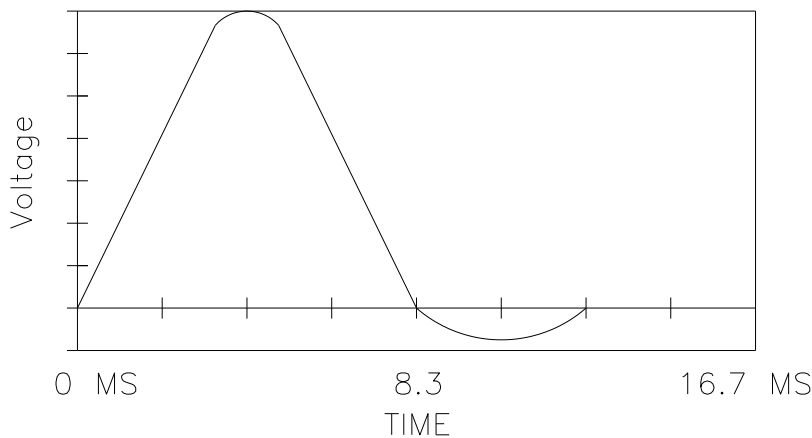

A rectified in the power source blocks either the negative or positive component of the sine wave. The feeder operates at 3,600 vibrations per minute on 60 Hertz current and at 3,000 VPM on 50 Hertz. When a rectified controller is supplied, the vibratory feeder has 8.3 milliseconds between pulses of current to the coil; therefore, greater amplitude can be achieved. Thinner leaf springs 1/16" to 3/16" thick or generally used to tune a rectified feeder since the thinner springs are more flexible and can be better tolerate the higher amplitude.

Resonance Tuning: The resonant frequency of a feeder is the frequency measured the instant after the feeder is shut off or at which it resonates when stuck with a hammer. It is the most efficient frequency of any tuned two mass vibratory feeder system.

Resonance Tuning Above the Power Line Frequency

Feeder tuned to a resonant frequency that is higher than the electrical service generally perform better under varying load and on bases that are not as rigid as they might be. Both loads and a less than rigid base will lower the resonant frequency of the vibratory system. When the feeder is tuned "High" the added load drives the frequency up the efficiency curve toward the power line frequency. The result is the feeder feeds better under load. As the load lessens the feeder tuning becomes stiffer thus compensating for the lighter load. High tuning also helps compensate for a less than rigid mounting platform.

Effect of Tuning Low

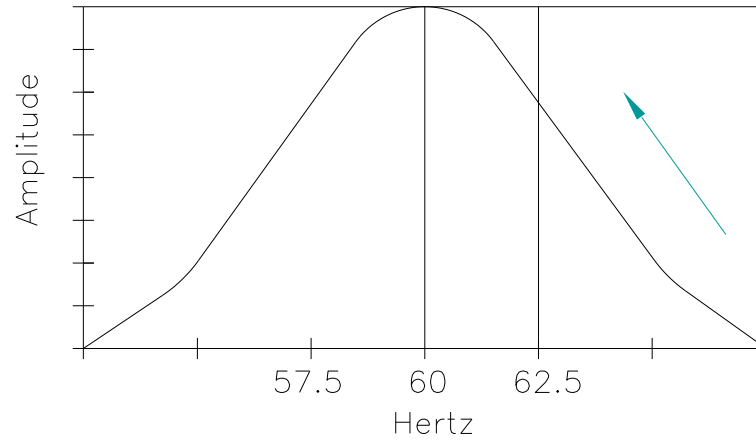

Resonance Tuning below the Power Line Frequency

When a feeder is tuned so that its resonance frequency is below the power line frequency, the feeder has no tolerance for load and/or a less rigid mounting platform. An increase in the quantity of parts in the feeder lowers the tuning of the system. The increase load drives the frequency further down the power curve away from the power line frequency. The result is a feeder that performs poorly, running slow under load and speeding up excessively as the bulk of the parts feed out.

Effect of Tuning High

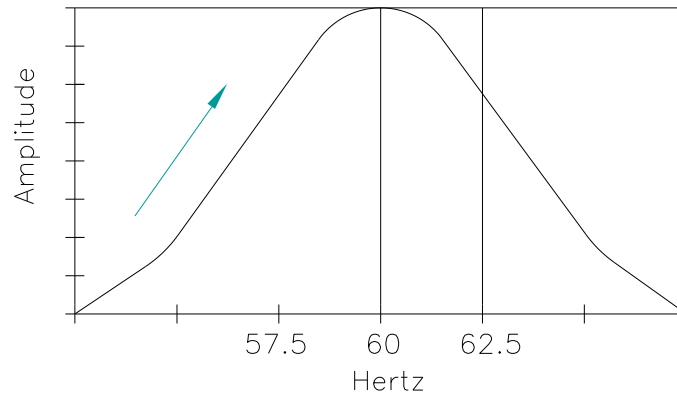

Feeders are normally tuned by adding or removing springs. Mass can also be added to or removed from the bowl, track or pan and/or the base drive.

The most common used to check tuning is simply to loosen a clamping bolt on one of the banks of springs and observe the feeder. A more reliable method is to tune with a variable frequency controller.

Mechanical Tuning

If a vibratory feeder is not feeding well, check the following:

- **Mounting Platform** – Be sure the stand or table is solid, rigid, level and all feet are planted firmly to the floor.
- **Feeder Toe Clamps and Center Bolts** – Be sure all toe clamps are tight and the bowl is seated properly in the toe clamps. On 18" and larger bowls, be sure the center bolt is tight (make sure that the spacer between the bowl bottom and the top of the cross-arm is in place failure do so will result in the dome of the bottom being damage).

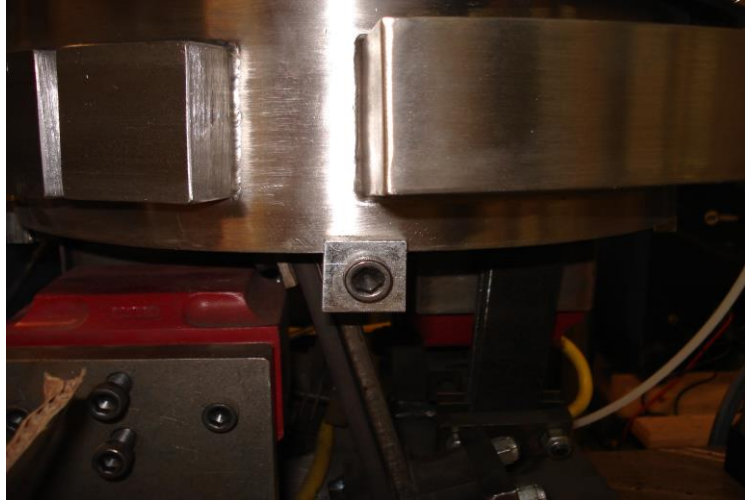

Toe clamp attaches bowl to drive

Rubber Mounting Feet – Check the rubber mounting feet by prying up lightly under the base drive at the feet and look for separation between the foot and the base, or the rubber and the metal mount. If see separation, you have to tighten the foot to the base or replace the foot itself.



Rubber Mounting Feet

Coil – Check to see if coil(s) is working by turning on the unit and placing a ferrous object, such as a screwdriver, close the coil air gap. If the metal is drawn to the coil(s), it is working. Do not expect this to be a strong attraction.

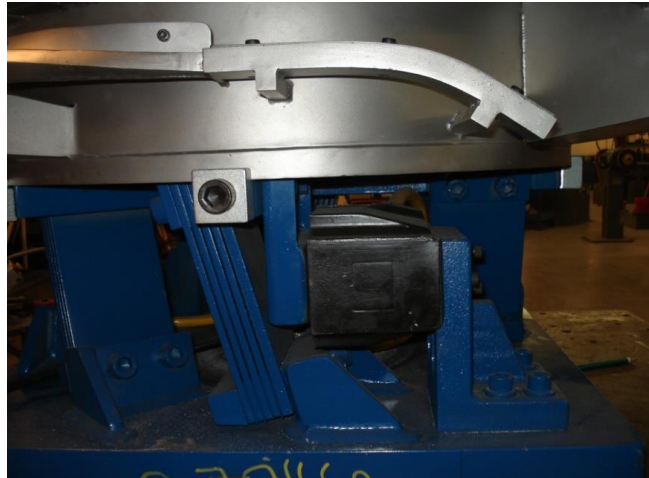

Coil – Air Gap

Air Gap – Check the air gap between the coils and the armature. On an AC unit the gap should be .015" - .020" on 4.5" and 6" feeders and .025" on 8" through 24" feeders. On all rectified units the air gap should be at least .060" and depending on the size of the feeder up to .100". The gap should always be even and the parallel across the face of the coil do not set the coil armature air gap too close as the pole faces will hammer. Try to set the air gap as close as possible and still not hammer when full on or when starting. The wider the gap the more amperes the unit will draws. Check the air gap by turning the unit full on and passing a piece of paper through the gap, if the paper is marked, the gap is too close.

Checking the Tuning

Check the tuning by turning on the unit and adjusting the control so that the parts just start to move in the bowl. Break one bolt loose on one bank of springs while you observe the parts in the bowl. If the feeder speed up and continues to do so as you continue to loosen the bolt, the feeder is over tuned and the resonance frequency will have to be dropped. This is the most common tuning problem as the springs tend to “work harden” over time. Tune the unit by removing a spring, or by replacing one with a thinner spring. If the feeder slows down, the drive is under tuned and a spring or springs will have to be added. When you are trying to achieve the proper resonant frequency, add the spring or spring to the bank that has the fewer amounts on, it wise to try to even the amount of spring per bank, if all is the same add one at your ease.

If you have an area that has excessive bounce, an additional spring or springs added under that part of the bowl will tend to reduce the bounce. Springs can be removed from one bank, where additional bounce might be needed or will not affect orientation or feed rate, to another bank under an area of concern in the bowl.

Generally, when the number of springs required cannot be split evenly among all the banks, the heavier spring bank should be at the coils. It is good practice to put the thicker springs toward the cross-arm with the thinner springs away from cross-arm.



Spring Bank

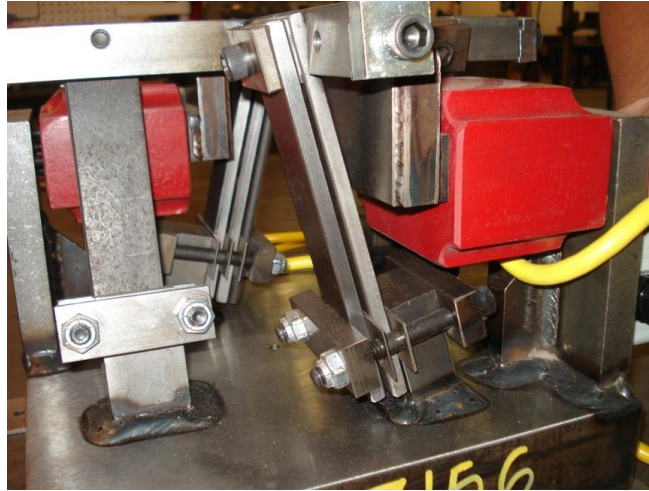

Sliding Spring Clamp

Check tuning by loosening one spring clamping bolt, if the unit speeds up, remove a spring, and if it slows down add a spring. Take care to use the correct length of bolt(s) when changing springs. On some older drives the bolt may bottom out against the pole face mount, if it is too long it will not clamp the springs tight causing a tuning issue.

On the 8" up to 15" units the clamp(s) can be raise but only to the top of the post. To tune, raise or lower these clamps in small increments as the force of the springs increases or decreases by the cube of the length.

The unit is properly tuned when the feeder speeds up as you initially break the bolt loose and then slows down as you continue to loosen the bolt.

Torque all bolts, especially spring and toe clamp bolts, to at least 80% of their rated torque.

Springs

Springs connect the feeder base mass to the bowl, track or pan mass. Everything attached to the top of the spring is part of the bowl, track and pan. The bowl, track and pan are a portion of a feed system that is supposed to vibrate. The much heavier mass of the drive base, plate and/or table contribute to how well the vibration is transferred to the bowl, track or pan.



Various Springs Sizes

Springs come in various lengths, widths, and thickness to match the requirements of the vibratory feeder.

Springs are made from harden steel or fiberglass. Thicker steel springs $\frac{1}{4}$ " and up are used on full wave units, rectified or half wave units typically use $\frac{1}{8}$ " steel springs or thinner as the thinner springs handle the greater amplitude better.

All feeders with fiberglass springs are rectified.

Spring Force

Spring force is amount of force required to deflect a spring and the amount of load it will return when deflected. Spring force is an expression used to describe the stiffness of a spring. A full wave feeder, because it has a shorter time of cycle, requires about 4 times the spring force to return the same amount of mass as a rectified or half wave feeder.

Mazza's rule of the square of the numerators

Rule of thumb used to estimate spring force

When trying to estimate spring force required for a given situation, ***Mazza's Rule of the Square of the Numerators*** works well in most situations.

The spring force or stiffness of a given spring, for a feeder, can be compared to other springs by using ***Mazza's Rule of the Square of the Numerators***. Estimating springs required to replace a spring of a different thickness can be determined by the following method.

1. Measure the thickness of the spring to be replaced in the 16th of an inch.
2. Square the numerator of that fraction.
3. Measure the thickness in 16th of an inch of the springs available to replace the broken spring.
4. Add the squares of the numerators of the replacement springs, to match as close as possible, the square numerator of the broken spring.

For example, if a 3/8" thick spring breaks and you do not have another 3/8" spring to replace it, two 1/4" thick springs and one 1/8" spring (or four 3/16" thick springs) will replace it. Be sure to put spacer between each spring.

To calculate the spring force in the example-

- Convert 3/8 to the common denominator – 6/16
 - Square the numerator – $6^2 = 36$
- A spring that is 6/16" (or 3/8") thick has a force value of 36
 -
- Convert 1/4 to the common denominator - 4/16
 - Square the numerator – $4^2 = 16$
- A spring that is 4/16" (or 1/4") thick has a force value of 16
 - $16 + 16 = 32$. Two 1/4" springs are not quite enough
 - Convert 1/8 to the common denominator - 2/16
 - Square the numerator – $2^2 = 4$
 - $16 + 16 + 4 = 36$

Two 1/4 "thick springs and one 1/8" thick spring have a combined force value of 36, equal to one 3/8" thick spring.

Four 3/16" thick springs also equal one 3/8" thick spring in force value.

- Square the numerator – $3^2 = 9$
 - $9 + 9 + 9 + 9 = 36$

NEMA ENCLOSURES

NOTE: This material is derived from National Electrical Manufacturers Association for Electrical Equipment, NEMA 250, "Enclosures for Electrical Equipment (1000 Volts Maximum)," copyright 1997 by NEMA... The information contained herein is not intended to be complete descriptions.

Refer to NEMA Standard 250 for complete details.

TYPE Application & Description

Type 1: Applies to enclosures that are intended for indoor use primarily to provide some protection against contact with the enclosed equipment or locations where non-typical service conditions do not exist.

Type 3: For Enclosures that used for outdoor use primarily to provide some protection against windblown dust, rain, and sleet: resistant and undamaged by the formation of ice on the enclosure.

Type 3R: For enclosures that are used in the outdoors primarily to provide a protection against falling rain and sleet; undamaged by the formation of ice on the enclosure.

Type 4: For enclosures that are used in indoor or outdoor use to provide a protection against windblown dust and rain, splashing water, and hose directed water; undamaged by the formation of ice on the enclosure.

Type 4X: For enclosures that are used for indoor or outdoor use to provide a protection against corrosion, windblown dust and rain, splashing water, and hose-directed water; undamaged by the formation of ice on the enclosure.

Type 6: Submersible enclosures are suitable for application where the equipment may be subject to submersion. The enclosure design will depend upon the specified conditions of pressure and time. The enclosure will also remain undamaged by the formation of ice on the enclosure.

Type 9: Hazardous location enclosures - Class II, Group E, F or G. These enclosures are designed to meet the requirements of the "Canadian Electrical Code" Part I for Class II It hazardous locations, and CSA codes section 18 Class II Group E, f, and G.

Class II Group E - atmosphere containing metal dust.

Class II Group F - atmosphere containing carbon black, coal, or coke dust.

Class II Group G - atmosphere containing flour, starch or grain dust.

Type 12: For enclosures that will operate primarily indoors. Industrial applications are typical where the enclosures are oil tight.

Type 12K: These enclosures that will operate primarily indoors and have knockouts, Industrial applications are typical where the enclosures are oil tight.

Type 13: The cover is held in place with screws, bolts or other suitable fasteners, with a continuous gasket construction. The fastener parts are held captive when the door is opened. There are no holes through the enclosures for mounting or attaching controls inside the enclosure, and no conduit knock-outs or openings. Mounting feet, brackets, or other mounting means are provided. These enclosures are suitable for application to machine tools and other industrial processing machines where oil, coolants, water, filings, dust or lint may enter, seep into or infiltrate the enclosure through mounting holes, unused conduit knock-outs, or holes used for mounting equipment with the enclosure.

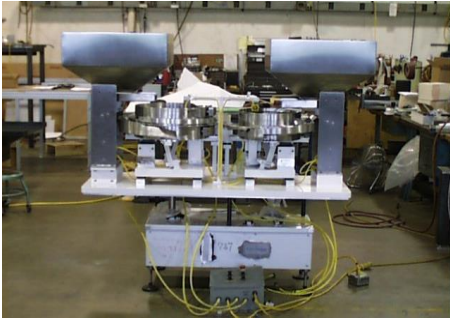

Tuning 101

Tuning a Storage Hopper

1. Fill the hopper with parts.
2. Check the power supply.
3. Check the coil gap, set at .040 to .050 and parallel.
4. Set the paddle arm or non-contact switch so that the hopper will supply the bowl feeder with one to two layers of parts.
5. Check the tuning as follows:
 - When the lower spring bolt is loosened and the parts in the hopper tray cease moving, the hopper is under-tuned. A spring should be added to one of the spring banks. After the spring has been added and the bolts tightened, turn the hopper and loosen the lower bolt again. If parts movement speeds up slightly as the bolt is loosened, the hopper is then tuned.
 - If parts movement increases sharply when the lower bolt is loosened, the hopper is over-tuned. Remove one spring and tighten the bolts. Repeat this procedure until parts movement increases slightly as the lower bolt is loosened.

Precise tuning frequency may be measures using an “Amplitude Feed Back” controller.

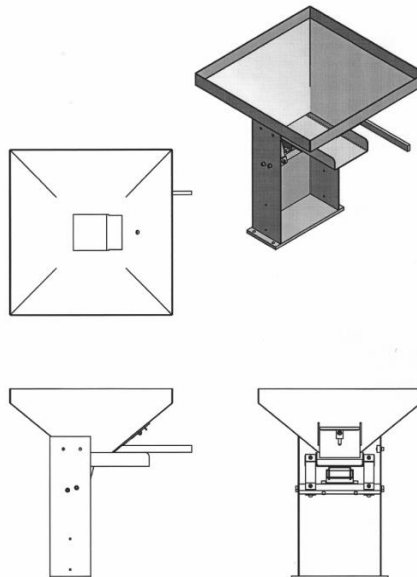



Tuning 101

Tuning a Inline Drive

1. Place some parts in the track.
2. Check the power supply.
3. Mount the inline base plate firmly in order to check tuning.
4. Check the coil gap, set at .020 to .025 and parallel.
5. Check to make sure all bolts are tight.
6. Check the gap between the bowl and inline, minimum of .020 clearances.
7. Turn the controller to a setting of approximately 35% to 45% of input voltage.
8. Loosen one screw on either of the two front springs approximately $\frac{1}{2}$ a turn. If the unit speeds up, it is over-tuned. Remove one spring and replace with a thinner spring, repeat until unit slows down when the screw is loosened a $\frac{1}{2}$ turn.

Precise tuning frequency may be measures using an "Amplitude Feed Back" controller.

Note: A track length should be mounted on the top bar of the inline base drive unit as follows:

A track section which is longer than the mounting bar should be mounted according to length. On the receiving end or entrance it should overhang the mounting bar a minimum of 1". On the discharge end or exit it should overhang a minimum of 2". The overhang ratio between the receiving and the discharge ends of the track should be 2 to 1 minimum.

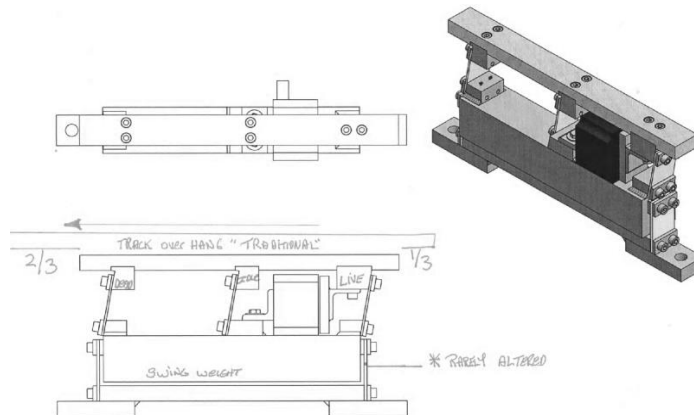

Tuning 101



Tuning a Bowl Drive

1. Place 1 to 2 layers of parts in the bowl.
2. Check the power supply.
3. Mount the drive base plate firmly in order to check tuning.
4. Check the coil gap, start at .060 for ½ wave and .030 for full wave, and it must be parallel.
5. Check to make sure all bolts are tight.
6. Check that all springs are separated by spacers, top and bottom.
7. Check the tuning by turning the unit on and adjusting the control so the parts just start to move in the feeder, break one bolt loose on one of the spring banks while you observe the parts in the feeder, if the feeder speeds up as you loosen the bolt, the feeder is over-tuned remove or lower the clamp on the smaller drive, if the feeder slows down then it is under-tuned and a spring will need to be added or raise the clamp on the smaller unit, the most common tuning problem as the spring tend to work harden over time.

Precise tuning frequency may be measures using an “Amplitude Feed Back” controller.

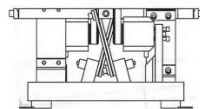
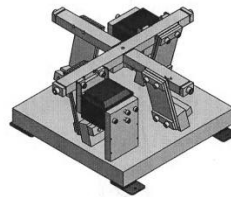
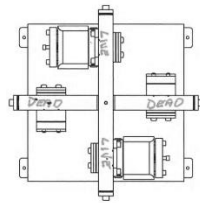

Tuning 101

Definition: Spring Force – The amount of force – (2 Mass system = Drive + Bowl).

Required to deflect a spring & the amount of load it will return when deflected.

Mazza's Rule of the square of the numerators makes a conversion list of all spring in chart form: $1/16'' = 1$

$$1/8'' = 4$$

$$3/16'' = 9$$

$$1/4'' = 16$$

$$5/16'' = 25$$

$$3/8'' = 36$$

Explain "Resonant Frequency" The most efficient frequency of any.

Prefer tuning 1.5 to 3 H = above existing power frequency.

Example:

Rectified 60 cycles = 61.5 to 63

Rectified 50 cycles = 51.5 to 53

Example:

ST.AC 60 cycles = 121.5 to 123

ST.AC 120 cycles = 101.5 to 103 Hertz

Explain rectified vs. Full wave Use Pix of Sine Waves

Terms to define: Hunting – discord tone

Explain: Why spring placement is critical to performance i.e. live bank dead bank.

Fundamentals: Relating to or produced by the lowest component of a complex vibration. (Definition Marion Webster Collegiate Dictionary)

Define under-tuned vs. over-tuned

“Procedure for test i.e., why systemic order is important to reveal the tuning problem pix #2 #1 to show simulation of reducing spring force naturally.

Include spring R.C. = 28 & why? Reliable test standards



MORE “NATURAL”

Simulation for reducing spring force

Add notes: Most tuning manuals say that the coil gap does not affect tuning! Though true, it is an ambiguous statement, due to opening the gap too wide or closing it too close will both result in diminished power to the secondary mass. (The bowl)

Track: 1/3 – 2/3 rule – inline

- Demonstrate with strobe the mechanical movement of coil assembly etc. use heat sensor to prove or disprove coil gap theory.

Additional notes: Spring spacer importance, cocked lug or bent springs can create pre-loaded condition – and break springs thickest one first.

- Strobe will also reveal a cracked spring and should be used after all bolts are checked for proper torque and coil gaps.
 - 1.) Bolt stretch or “seat” after several months of running and can cause undertone condition.
 - 2.) Mounting feet are a key to control of the primary energy mass plate they should be height matched and duro-meter should be equal.
 - 3.) If mass plate is inadequate the entire job will turn on the table mass can be added to the plate, but it will reduce the frequency and you will add springs. (see marked page on good rules)
 - 4.) Test coil gap if hammering with paper. (On large units it is hard to know which one is too close)
 - 5.) Sometime when the unit is tuned part still won’t feed try different parts if they feed the bowl needs help via a mechanical “tooth” X-sanding the track, Brushlon etc.

Notes:

Notes:

Notes: