

Lifting Lugs

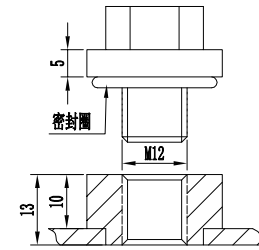

Air(Oil) release plug

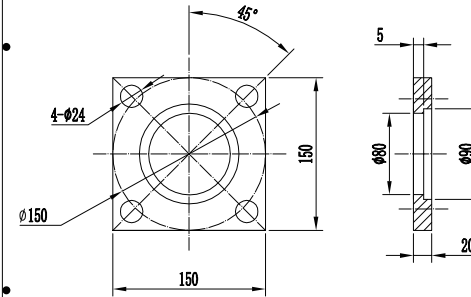

Flange

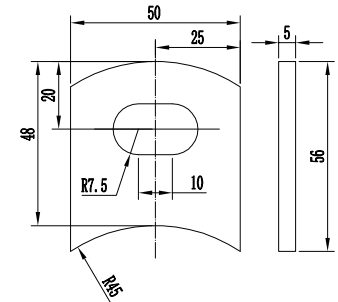

Fixing plate

The meanings of each letter in the figure are as follows:

H - Center distance 1000mm

L - Total length of the manifold

N - Total number of Radiator Fins

B - Radiator blade width 520mm

P - Iron Rod bar Distance 150mm

P1 - Iron Rod bar Distance 350mm

8	150X150	Flange	2			
7	As drawing	Fixing plate	2			
6		Cover	2			
5	$\Phi 10$	Stiffening rod				
4		Fin	N			
3	M12 $\Phi 18$	Air(Oil) release plug	2			
2	65X60X12	Lifting Lugs	2			
1	$\Phi 89$	Header Tuber	2			

No.	Spec.	Name	Nos	Material	Weight	Remark
				PCH-N/520		
				Mark Weight		
Mark	No	Document NO	Sign	Date		
Design	Huang	Standard				
Check		Approval				
Check	Jiang					
Process		Date	2022.09			



Yueqing City Ouwei Electric Co.,Ltd

底图总号

签字

日期

5FIN X 1000 X 520mm