

ULTEM™ FILAMENT AM9085F

DESCRIPTION

ULTEM™ AM9085F filament is a high performance polyetherimide blend product manufactured from ULTEM™ 9085 resin. It is available in black and natural (unpigmented) colors. It provides high heat resistance and mechanical strength, is UL94 V-0 compliant at 1.5 and 3.0 mm (Blue Cards are available on UL IQ Database), and meets FAR 25.853 and OSU 55/55 with low toxicity, smoke, and flame evolution.

TYPICAL PROPERTY VALUES

Revision 20201207

PROPERTIES	TYPICAL VALUES	UNITS	TEST METHODS
MECHANICAL			
Tensile Modulus			
XY ORIENTATION	2176	MPa	ASTM D638
XZ ORIENTATION	2555	MPa	ASTM D638
ZX ORIENTATION	2439	MPa	ASTM D638
Tensile Stress, brk, Type I, 5 mm/min			
XY ORIENTATION	62	MPa	ASTM D638
XZ ORIENTATION	80	MPa	ASTM D638
ZX ORIENTATION	45	MPa	ASTM D638
Tensile Strain, brk, Type I, 5 mm/min			
XY ORIENTATION	5.1	%	ASTM D638
XZ ORIENTATION	5.8	%	ASTM D638
ZX ORIENTATION	2.3	%	ASTM D638
Flexural Modulus, 1.3 mm/min			
XY ORIENTATION	2126	MPa	ASTM D790
XZ ORIENTATION	2550	MPa	ASTM D790
ZX ORIENTATION	2070	MPa	ASTM D790
Izod Impact, notched, 23°C⁽¹⁾			
XY ORIENTATION	104	J/m	ASTM D256
XZ ORIENTATION	100	J/m	ASTM D256
ZX ORIENTATION	33	J/m	ASTM D256
Izod Impact, un-notched, 23°C			
XY ORIENTATION	763	J/m	ASTM D256
XZ ORIENTATION	1003	J/m	ASTM D256
ZX ORIENTATION	131	J/m	ASTM D256
THERMAL			
HDT, 1.82 MPa, 3.2 mm, unannealed			
XY ORIENTATION	175	°C	ASTM D648
XZ ORIENTATION	175	°C	ASTM D648
ZX ORIENTATION	165	°C	ASTM D648
Coefficient of Thermal Expansion - flow			
XY ORIENTATION	57.1	µm/(m·°C)	ASTM E831
XZ ORIENTATION	60.6	µm/(m·°C)	ASTM E831
ZX ORIENTATION	62.1	µm/(m·°C)	ASTM E831
Coefficient of Thermal Expansion - x-flow			

PROPERTIES	TYPICAL VALUES	UNITS	TEST METHODS
XY ORIENTATION	58.3	$\mu\text{m}/(\text{m}\cdot^{\circ}\text{C})$	ASTM E831
XZ ORIENTATION	61.1	$\mu\text{m}/(\text{m}\cdot^{\circ}\text{C})$	ASTM E831
ZX ORIENTATION	62.9	$\mu\text{m}/(\text{m}\cdot^{\circ}\text{C})$	ASTM E831
PHYSICAL			
Density	1.275	g/cm^3	ASTM D792
ELECTRICAL			
Volume Resistivity			
XY ORIENTATION	1.07E+15	Ohm-cm	ASTM D257
XZ ORIENTATION	1.1E+15	Ohm-cm	ASTM D257
Dielectric Constant - 100 MHz			
XY ORIENTATION	2.54	-	ASTM D150
XZ ORIENTATION	2.73	-	ASTM D150
Dissipation Factor - 100 MHz			
XY ORIENTATION	0.00233	-	ASTM D150
XZ ORIENTATION	0.003	-	ASTM D150
Dielectric Constant - 500 MHz			
XY ORIENTATION	2.53	-	ASTM D150
XZ ORIENTATION	2.72	-	ASTM D150
Dissipation Factor - 500 MHz			
XY ORIENTATION	0.005	-	ASTM D150
XZ ORIENTATION	0.00567	-	ASTM D150
Dielectric Constant - 1000 MHz			
XY ORIENTATION	2.52	-	ASTM D150
XZ ORIENTATION	2.71	-	ASTM D150
Dissipation Factor - 1000 MHz			
XY ORIENTATION	0.004	-	ASTM D150
XZ ORIENTATION	0.004	-	ASTM D150
FLAME CHARACTERISTICS			
FAA Flammability			
XY ORIENTATION, 1.5mm	PASS	-	FAR 25.853
OSU total heat release (2 minute test)			
XY ORIENTATION, 1.5mm	44	$\text{kW}\cdot\text{min}/\text{m}^2$	FAR 25.853
OSU peak heat release rate (5 minute test)			
XY ORIENTATION, 1.5mm	45	kW/m^2	FAR 25.853
UL94 Flame Class Rating ⁽²⁾			
XY ORIENTATION, 1.5mm	V-0	-	-
XZ ORIENTATION, 1.5mm	V-0	-	-
ZX ORIENTATION, 1.5mm	V-0	-	-
XY ORIENTATION, 3.0mm	V-0	-	-
XZ ORIENTATION, 3.0mm	V-0	-	-
ZX ORIENTATION, 3.0mm	V-0	-	-

(1) Izod impact strength test coupons were printed using a Stratasys FORTUS† 900mc printer at high print density (88.5%).

(2) UL results provided herein may not be sufficient to waive end use part testing for UL listing. Contact UL for further details.

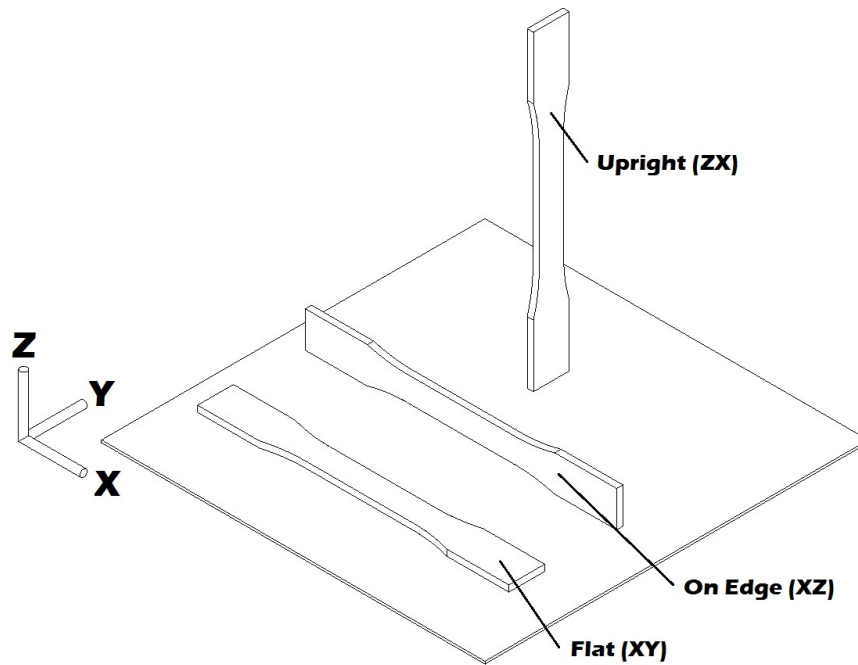

DISCLAIMER

Typical values only. Not intended for design or specification purposes. Variations within normal tolerances are possible for various colors. Test coupons were printed using a Stratasys FORTUS† 400mc printer under standard parameters unless otherwise noted.

† Any brands, products or services of other companies referenced in this document are the trademarks, service marks and/or trade names of their respective holders.

DISCLAIMER

Any sale by SABIC, its subsidiaries and affiliates (each a "seller"), is made exclusively under seller's standard conditions of sale (available upon request) unless agreed otherwise in writing and signed on behalf of the seller. While the information contained herein is given in good faith, SELLER MAKES NO WARRANTY, EXPRESS OR IMPLIED, INCLUDING MERCHANTABILITY AND NON-INFRINGEMENT OF INTELLECTUAL PROPERTY, NOR ASSUMES ANY LIABILITY, DIRECT OR INDIRECT, WITH RESPECT TO THE PERFORMANCE, SUITABILITY OR FITNESS FOR INTENDED USE OR PURPOSE OF THESE PRODUCTS IN ANY APPLICATION. Each customer must determine the suitability of seller materials for the customer's particular use through appropriate testing and analysis. No statement by seller concerning a possible use of any product, service or design is intended, or should be construed, to grant any license under any patent or other intellectual property right.