



Product Data

Upflow/Downflow/Horizontal Gas-Fired, 1-Stage and 2-Stage Induced Draft Furnaces with High Efficiency Motor

Upflow, Downflow, Horizontal Right/Left

Single Stage		Two Stage
S8B1A026M2PSC	S8X1A026M2PSC	S8X2A040M3PSC
S8B1A040M3PSC	S8X1A040M3PSC	S8X2B060M4PSC
S8B1B040M2PSC	S8X1B040M2PSC	S8X2B080M4PSC
S8B1B060M4PSC	S8X1B060M4PSC	S8X2C080M5PSC
S8B1B080M4PSC	S8X1B080M4PSC	S8X2C100M5PSC
S8B1C080M5PSC	S8X1C080M5PSC	S8X2D120M5PSC
S8B1C100M5PSC	S8X1C100M5PSC	
S8B1D120M5PSC	S8X1D120M5PSC	

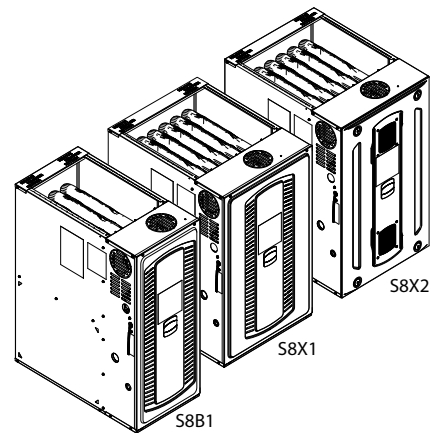

Note: Models may have a "T" in the 12th digit designating they meet California less than 40 ng/J (NOx) emissions requirements.

Note: Graphics in this document are for representation only. Actual model may differ in appearance.



Table of Contents

General Features	3
Features and Benefits.....	4
Accessories.....	5
Product Specifications.....	6
Airflow Tables	12
CFM Versus Temperature Rise.....	16
Wiring Diagrams.....	17
Electrical Connections	20
Field Wiring	20
Outline Drawing	21



General Features

NATURAL GAS MODELS

Central Heating furnace designs are certified by Intertek for both natural and L.P. gas. Limit setting and rating data were established and approved under standard rating conditions using American National Standards Institute standards.

SAFE OPERATION

The Integrated System Control is a solid state device which continuously monitors for presence of flame when the system is in the heating mode of operation. Dual solenoid combination gas valve and regulator provide additional safety.

QUICK HEATING

Durable, cycle tested, heavy gauge **tubular aluminized steel heat exchanger** quickly transfers heat to provide warm conditioned air to the structure. **Low energy power vent blower**, to increase efficiency and provide a discharge of gas fumes to the outside.

BURNERS

Multiport, Inshot burners will give years of quiet and efficient service. All models can be converted to **L.P. gas** with LP conversion kit.

INTEGRATED SYSTEM CONTROL

Exclusively designed operational program provides total control of furnace limit sensors, blowers, gas valve, flame control and includes self diagnostics for ease of service.

ENERGY EFFICIENT OPERATION

Air-Tite™ cabinet design is certified to <1% air leakage per ASHRAE 193 "Method of Test for Determining the Airtightness of HVAC Equipment."

AIR DELIVERY

The 9 speed constant torque blower motor has sufficient airflow for most heating and cooling requirements and will switch from heating to cooling speeds on demand from room thermostat.

STYLING

Heavy gauge steel and "wrap-around" cabinet construction is used in the cabinet with baked-on enamel finish for strength and beauty. Every orientation has at least two venting options. There are no knockouts on cabinet.

FEATURES AND GENERAL OPERATION

The S-Series furnace utilizes a Silicon Nitride Hot Surface Ignition system, which eliminates the waste of a constant burning pilot. The integrated system control lights the main burners upon a demand for heat from the room thermostat. Complete front service access.

- a. Low energy power venter
- b. Vent proving pressure switches.



Features and Benefits

80% AFUE on S8*1 and S8X2 FURNACE MODELS

Lowers utility bills

ELECTRICALLY EFFICIENT

Efficient airflow design reduces electrical energy use

34 INCH TALL

Lighter, easier to move and fit into tight spaces like short basements or tight closets

Works great with larger, high-efficiency coils

No knockouts

4-WAY MULTI-POISE

S8*1 – 8 SKU's – Upflow / Downflow / Horizontal Left / Horizontal Right

S8X2 – 6 SKU's – Upflow / Downflow / Horizontal Left / Horizontal Right

Added application flexibility and reduction in specification errors

AIRFLOW

At least 400 CFM/ton at 0.5 in. H₂O external static pressure

REGULATORY

All models are air tight; 1% or less air leakage as per ASHRAE 193

Open vestibule design provides a full 34" high open vestibule for ease of installation and service

DIMENSIONS

Widths are industry standard: 14.5", 17.5", 21" and 24.5"

Depth remains approximately 28"

Cabinet is compatible with industry standard coils, as well as, other accessories

INTEGRATED FURNACE CONTROL

Setup / Status / Diagnostics / Digital Display

No dip switches

Last six errors stored

Dry contact EAC and HUM connections

All Molex connections; no spade terminals

Low voltage labeled above and below

Rain shield over IFC keeps condensate off the control

TUBULAR ALUMINIZED STEEL HEAT EXCHANGER

VORTICA II BLOWER, DESIGNED EXCLUSIVELY FOR THE S-SERIES FURNACE

Improved airflow efficiency

Durable, easy to clean, housing

Single piece belly band/ motor arm assembly

Blower deck has full-length rails for easy removal and replacement, regardless of poise

FOUR-WAY MULTI-POISE (UPFLOW, DOWNFLOW, HORIZONTAL LEFT AND RIGHT)

Easier to specify

Shipped ready to install (no conversion kits required)

Every model has at least two venting options



Accessories

Table 1. Accessories

Model Number	Description	Use with
BAYHANG	Horizontal Hanging Kit	All Furnaces
BAYLIFTB	Dual Return Kit (B size extension)	B Cabinet Furnaces
BAYLIFTC	Dual Return Kit (C size extension)	C Cabinet Furnaces
BAYLIFTD	Dual Return Kit (D size extension)	D Cabinet Furnaces
BAYBASE205	Downflow Subbase	All Furnaces in Downflow orientation
BAYSF1165AA ^(a)	1" SlimFit Box with MERV 4 Filter	All Furnaces
BAYSF1255BA	1" SlimFit Filter and Insulated Frame	All furnaces when used in side return application B Cabinet furnaces only when in bottom return application
FLRSF1255	1" Filter replacement (Qty 12)	BAYSF1255BA
BAYVENT600A	Internal venting kit	B, C, and D Furnaces in Downflow orientation
BAYVENT800B	Masonry Chimney Vent Kit	All furnaces
BAYSWT20AHALTAA	High Altitude Pressure Switch Kit	S8*1A026M2P*
BAYSWT21AHALTAA	High Altitude Pressure Switch Kit	S8*1A040M3P*, S8*1B040M2P*
BAYSWT22AHALTAA	High Altitude Pressure Switch Kit	S8X2A040M3P*
BAYSWT14AHALTAB	High Altitude Pressure Switch Kit	S8*1C080M5P*, S8*1C100M5P*, S8*1D120M5P*
BAYSWT15AHALTAA	High Altitude Pressure Switch Kit	S8*1B060M4P*, S8*1B080M4P*
BAYSWT16AHALTAB	High Altitude Pressure Switch Kit	S8X2C080M5P*
BAYSWT17AHALTAA	High Altitude Pressure Switch Kit	S8X2B060M4PSAAA
BAYSWT18AHALTAA	High Altitude Pressure Switch Kit	S8X2B080M4P*
BAYSWT19AHALTAA	High Altitude Pressure Switch Kit	S8X2C100M5P*
BAYSWT23AHALTAA	High Altitude Pressure Switch Kit	S8X2B060M4PSAAB & later, S8X2B060M4PTAAA & later
BAYSWT24AHALTAA	High Altitude Pressure Switch Kit	S8X2D120M5P*
BAYLPSS400*	Propane Conversion Kit with Stainless Steel Burners	All Furnaces except S8B1A026, S8X1A026
BAYLPSS410*	Propane Conversion Kit with Stainless Steel Burners	S8B1A026, S8X1A026 Furnaces only
PIP02095	U fitting for gas piping	All Furnaces for right hand gas entry

^(a) Airflow greater than 1600 CFM requires dual returns



Product Specifications

MODEL	S8*1A026M2PSC (a)	S8*1A040M3PSC (a)	S8*1B040M2PSC (a)
Type	Upflow / Horizontal / Downflow	Upflow / Horizontal / Downflow	Upflow / Horizontal / Downflow
RATINGS (b)			
Input BTUH	26,000	40,000	40,000
Capacity BTUH (ICS) (c)	21,000	32,300	32,500
Temp. Rise (Min. - Max.) °F	25 - 55	30 - 60	30 - 60
AFUE - Rating (c)	80	80	80
Return Air Temp. (Min. - Max.) °F	55°F - 80°F	55°F - 80°F	55°F - 80°F
BLOWER DRIVE	DIRECT	DIRECT	DIRECT
Diameter - Width (in.)	11 X 8	11 X 8	11 X 8
No. Used	1	1	1
Speeds (No.) (d)	CTM - 9	CTM - 9	CTM - 9
CFM vs. in. w.g.	See Fan Performance Table	See Fan Performance Table	See Fan Performance Table
Motor HP	1/3	1/2	1/3
R.P.M.	1050	1050	1050
Volts / Ph / Hz	120 / 1 / 60	120 / 1 / 60	120 / 1 / 60
FLA	4.1	6.4	4.1
COMBUSTION FAN - Type	SP	PSC	PSC
Drive - No. Speeds	Direct - 1	Direct - 1	Direct - 1
Motor RPM	3300	3300	3300
Volts/Ph/Hz	120 / 1 / 60	120 / 1 / 60	120 / 1 / 60
FLA	1.39	0.30	0.30
Inducer Orifice	0.90	1.20	1.15
FILTER - Furnished?	No	No	No
Type Recommended	High Velocity	High Velocity	High Velocity
Hi Vel. (No.-Size-Thk.)	1 - 14 X 25 - 1 in.	1 - 14 X 25 - 1 in.	1 - 16 X 25 - 1 in.
VENT PIPE DIAMETER - Min. (in.) (e)	4 Round	4 Round	4 Round
HEAT EXCHANGER - Type	Aluminized Steel	Aluminized Steel	Aluminized Steel
Gauge (Fired)	20 - 19	20 - 19	20 - 19
ORIFICES - Main			
Nat. Gas Qty. - Drill Size	2 - 51	2 - 45	2 - 45
L.P. Gas Qty. - Drill Size	2 - 59	2 - 56	2 - 56
GAS VALVE	Redundant - Single Stage	Redundant - Single Stage	Redundant - Single Stage
PILOT SAFETY DEVICE - Type	120 V SiNi Igniter	120 V SiNi Igniter	120 V SiNi Igniter
BURNERS - QTY	2	2	2
POWER CONN. - V/Ph/HZ (f)	120 / 1 / 60	120 / 1 / 60	120 / 1 / 60
Ampacity (Amps)	6.7	8.5	5.6
Max. Overcurrent Protection (Amps)	15	15	15
PIPE CONN. SIZE (IN.)	1/2	1/2	1/2
DIMENSIONS	H x W x D	H x W x D	H x W x D
Uncrated (in.)	34 x 14.5 x 28.75	34 x 14.5 x 28.75	34 x 17.5 x 28.75
Crated (in.)	35.5 x 16.5 x 30.87	35.5 x 16.5 x 30.87	35.5 x 19.5 x 30.87



Product Specifications

MODEL	S8*1A026M2PSC (a)	S8*1A040M3PSC (a)	S8*1B040M2PSC (a)
WEIGHT			
Shipping (Lbs.)/Net (Lbs.)	102 / 94	102 / 94	128 / 120

(a) Central Furnace heating designs are certified to ANSI Z21.47 - latest edition.

(b) For U.S. applications, above input ratings (BTUH) are up to 2,000 feet, derate 4% per 1,000 feet for elevations above 2,000 feet above sea level.

(c) Based on U.S. government standard tests

(d) 9 Speed constant torque ECM Blower Motor.

(e) Refer to the Installer's Guide.

(f) The above wiring specifications are in accordance with National Electric Code, however, installations must comply with local codes.

MODEL	S8*1B060M4PSC (a)	S8*1B080M4PSC (a)	S8*1C080M5PSC (a)
Type	Upflow / Horizontal / Downflow	Upflow / Horizontal / Downflow	Upflow / Horizontal / Downflow
RATINGS (b)			
Input BTUH	60,000	80,000	80,000
Capacity BTUH (ICS) (c)	48,700	65,100	64,700
Temp. Rise (Min. - Max.) °F	30 - 60	30 - 60	30 - 60
AFUE - Rating (c)	80	80	80
Return Air Temp. (Min. - Max.) °F	55°F - 80°F	55°F - 80°F	55°F - 80°F
BLOWER DRIVE	DIRECT	DIRECT	DIRECT
Diameter - Width (in.)	11 X 8	11 X 8	11 X 11
No. Used	1	1	1
Speeds (No.) (d)	CTM - 9	CTM - 9	CTM - 9
CFM vs. in. w.g.	See Fan Performance Table	See Fan Performance Table	See Fan Performance Table
Motor HP	3/4	3/4	1
R.P.M.	1050	1050	1050
Volts / Ph / Hz	120 / 1 / 60	120 / 1 / 60	120 / 1 / 60
FLA	9.2	9.2	10.9
COMBUSTION FAN - Type	PSC	PSC	PSC
Drive - No. Speeds	Direct - 1	Direct - 1	Direct - 1
Motor RPM	3300	3300	3300
Volts/Ph/Hz	120 / 1 / 60	120 / 1 / 60	120 / 1 / 60
FLA	0.30	0.29	0.30
Inducer Orifice	1.40	1.75	1.80
FILTER - Furnished?	No	No	No
Type Recommended	High Velocity	High Velocity	High Velocity
Hi Vel. (No.-Size-Thk.)	1 - 16 X 25 - 1 in.	1 - 16 X 25 - 1 in.	1 - 20 X 25 - 1 in.
VENT PIPE DIAMETER - Min. (in.) (e)	4 Round	4 Round	4 Round
HEAT EXCHANGER - Type	Aluminized Steel	Aluminized Steel	Aluminized Steel
Gauge (Fired)	20 - 19	20 - 19	20 - 19
ORIFICES - Main			
Nat. Gas Qty. - Drill Size	3 - 45	4 - 45	4 - 45
L.P. Gas Qty. - Drill Size	3 - 56	4 - 56	4 - 56
GAS VALVE	Redundant - Single Stage	Redundant - Single Stage	Redundant - Single Stage
PILOT SAFETY DEVICE - Type	120 V SiNi Igniter	120 V SiNi Igniter	120 V SiNi Igniter
BURNERS - QTY	3	4	4
POWER CONN. - V/Ph/HZ (f)	120 / 1 / 60	120 / 1 / 60	120 / 1 / 60
Ampacity (Amps)	12.0	12.0	14.1
Max. Overcurrent Protection (Amps)	15	15	15



Product Specifications

MODEL	S8*1B060M4PSC (a)	S8*1B080M4PSC (a)	S8*1C080M5PSC (a)
PIPE CONN. SIZE (IN.)	1/2	1/2	1/2
DIMENSIONS	H x W x D	H x W x D	H x W x D
Uncrated (in.)	34 x 17.5 x 28.75	34 x 17.5 x 28.75	34 x 21 x 28.75
Crated (in.)	35.5 x 19.5 x 30.87	35.5 x 19.5 x 30.87	35.5 x 23 x 30.87
WEIGHT			
Shipping (Lbs.)/Net (Lbs.)	132 / 124	137 / 129	142 / 134

(a) Central Furnace heating designs are certified to ANSI Z21.47 - latest edition.

(b) For U.S. applications, above input ratings (BTUH) are up to 2,000 feet, derate 4% per 1,000 feet for elevations above 2,000 feet above sea level.

(c) Based on U.S. government standard tests

(d) 9 Speed constant torque ECM Blower Motor.

(e) Refer to the Installer's Guide.

(f) The above wiring specifications are in accordance with National Electric Code, however, installations must comply with local codes.

MODEL	S8*1C100M5PSC (a)	S8*1D120M5PSC (a)
Type	Upflow / Horizontal / Downflow	Upflow / Horizontal / Downflow
RATINGS (b)		
Input BTUH	100,000	120,000
Capacity BTUH (ICS) (c)	80,700	98,000
Temp. Rise (Min. - Max.) °F	30 - 60	35 - 65
AFUE - Rating (c)	80	80
Return Air Temp. (Min. - Max.) °F	55°F - 80°F	55°F - 80°F
BLOWER DRIVE	DIRECT	DIRECT
Diameter - Width (in.)	11 X 11	11 X 11
No. Used	1	1
Speeds (No.) (d)	CTM - 9	CTM - 9
CFM vs. in. w.g.	See Fan Performance Table	See Fan Performance Table
Motor HP	3/4	1
R.P.M.	1050	1050
Volts / Ph / Hz	120 / 1 / 60	120 / 1 / 60
FLA	10.9	10.9
COMBUSTION FAN - Type	PSC	PSC
Drive - No. Speeds	Direct - 1	Direct - 1
Motor RPM	3300	3300
Volts/Ph/Hz	120 / 1 / 60	120 / 1 / 60
FLA	0.33	0.33
Inducer Orifice	2.50	2.15
FILTER - Furnished?	No	No
Type Recommended	High Velocity	High Velocity
Hi Vel. (No.-Size-Thk.)	1 - 20 X 25 - 1 in.	1 - 24 X 25 - 1 in.
VENT PIPE DIAMETER - Min. (in.) (e)	4 Round	4 Round
HEAT EXCHANGER - Type	Aluminized Steel	Aluminized Steel
Gauge (Fired)	20 - 19	20 - 19
ORIFICES - Main		
Nat. Gas Qty. - Drill Size	5 - 45	6 - 45
L.P. Gas Qty. - Drill Size	5 - 56	6 - 56
GAS VALVE	Redundant - Single Stage	Redundant - Single Stage
PILOT SAFETY DEVICE - Type	120 V SiNi Igniter	120 V SiNi Igniter



Product Specifications

MODEL	S8*1C100M5PSC (a)	S8*1D120M5PSC (a)
BURNERS - QTY	5	6
POWER CONN. - V/Ph/HZ (f)	120 / 1 / 60	120 / 1 / 60
Ampacity (Amps)	14.1	14.1
Max. Overcurrent Protection (Amps)	15	15
PIPE CONN. SIZE (IN.)	1/2	1/2
DIMENSIONS	H x W x D	H x W x D
Uncrated (in.)	34 x 21 x 28.75	34 x 24.5 x 28.75
Crated (in.)	35.5 x 23 x 30.87	35.5 x 26.5 x 30.87
WEIGHT		
Shipping (Lbs.)/Net (Lbs.)	144 / 136	160 / 152

(a) Central Furnace heating designs are certified to ANSI Z21.47 - latest edition.

(b) For U.S. applications, above input ratings (BTUH) are up to 2,000 feet, derate 4% per 1,000 feet for elevations above 2,000 feet above sea level.

(c) Based on U.S. government standard tests

(d) 9 Speed constant torque ECM Blower Motor.

(e) Refer to the Installer's Guide.

(f) The above wiring specifications are in accordance with National Electric Code, however, installations must comply with local codes.

Model	S8X2A040M3PSC (a)	S8X2B060M4PSC (a)	S8X2B080M4PSC (a)
Type	Upflow / Horizontal / Downflow	Upflow / Horizontal / Downflow	Upflow / Horizontal / Downflow
RATINGS (b)			
1st Stage Input BTUH	26,000	39,000	52,000
1st Stage Capacity BTUH (ICS)	20,900	31,500	42,500
2nd Stage Input BTUH	40,000	60,000	80,000
2nd Stage Capacity BTUH (ICS) (c)	32,200	48,700	65,000
1st Stage Temp. Rise (Min. - Max.) °F	20 - 50	20 - 50	25 - 55
2nd Stage Temp. Rise (Min. - Max.) °F	30 - 60	30 - 60	30 - 60
AFUE (%) (c)	80	80	80
Return Air Temp. (Min. - Max.) °F	55°F - 80°F	55°F - 80°F	55°F - 80°F
BLOWER DRIVE	DIRECT	DIRECT	DIRECT
Diameter - Width (in.)	11 X 8	11 X 8	11 X 8
No. Used	1	1	1
Speeds (No.) (d)	CTM - 9	CTM - 9	CTM - 9
CFM vs. in. w.g.	See Fan Performance Table	See Fan Performance Table	See Fan Performance Table
Motor HP	1/2	3/4	3/4
R.P.M.	1050	1050	1050
Volts / Ph / Hz	120 / 1 / 60	120 / 1 / 60	120 / 1 / 60
FLA	6.4	9.2	9.2
COMBUSTION FAN - Type	PSC	PSC	PSC
Drive - No. Speeds	Direct - 2	Direct - 2	Direct - 2
Motor RPM	3300/2600	3300/2600	3300/2600
Volts/Ph/Hz	120 / 1 / 60	120 / 1 / 60	120 / 1 / 60
FLA	0.30	0.30	0.33
Inducer Orifice	1.20	1.40	1.75
FILTER - Furnished?	No	No	No
Type Recommended	High Velocity	High Velocity	High Velocity
Hi Vel. (No.-Size-Thk.)	1 - 14 X 25 - 1 in.	1 - 16 X 25 - 1 in.	1 - 16 X 25 - 1 in.
VENT PIPE DIAMETER - Min. (in.) (e)	4 Round	4 Round	4 Round
HEAT EXCHANGER - Type	Aluminized Steel	Aluminized Steel	Aluminized Steel



Product Specifications

Model	S8X2A040M3PSC (a)	S8X2B060M4PSC (a)	S8X2B080M4PSC (a)
Gauge (Fired)	20 - 19	20 - 19	20 - 19
ORIFICES - Main			
Nat. Gas Qty. - Drill Size	2 - 45	3 - 45	4 - 45
L.P. Gas Qty. - Drill Size	2 - 56	3 - 56	4 - 56
GAS VALVE	Redundant - Two Stage	Redundant - Two Stage	Redundant - Two Stage
PILOT SAFETY DEVICE - Type	120 V SiNi Igniter	120 V SiNi Igniter	120 V SiNi Igniter
BURNERS - QTY	2	3	4
POWER CONN. - V/Ph/HZ (f)	120 / 1 / 60	120 / 1 / 60	120 / 1 / 60
Ampacity (Amps)	8.5	12.0	12.0
Max. Overcurrent Protection (Amps)	15	15	15
PIPE CONN. SIZE (IN.)	1/2	1/2	1/2
DIMENSIONS	H x W x D	H x W x D	H x W x D
Uncrated (in.)	34 x 14.5 x 28.75	34 x 17.5 x 28.75	34 x 17.5 x 28.75
Crated (in.)	35.5 x 16.5 x 30.87	35.5 x 19.5 x 30.87	35.5 x 19.5 x 30.87
WEIGHT			
Shipping (Lbs.)/Net (Lbs.)	102 / 94	132 / 124	137 / 129

(a) Central Furnace heating designs are certified to ANSI Z21.47 - latest edition.

(b) For U.S. applications, above input ratings (BTUH) are up to 2,000 feet, derate 4% per 1,000 feet for elevations above 2,000 feet above sea level.

(c) Based on U.S. government standard tests

(d) 9 Speed constant torque ECM Blower Motor.

(e) Refer to the Installer's Guide.

(f) The above wiring specifications are in accordance with National Electric Code, however, installations must comply with local codes.

Model	S8X2C080M5PSC (a)	S8X2C100M5PSC (a)	S8X2D120M5PSC (a)
Type	Upflow / Horizontal / Downflow	Upflow / Horizontal / Downflow	Upflow / Horizontal / Downflow
RATINGS (b)			
1st Stage Input BTUH	52,000	65,000	84,000
1st Stage Capacity BTUH (ICS)	41,800	52,300	67,800
2nd Stage Input BTUH	80,000	100,000	120,000
2nd Stage Capacity BTUH (ICS) (c)	64,900	80,600	98,000
1st Stage Temp. Rise (Min. - Max.) °F	30 - 60	25 - 55	30 - 60
2nd Stage Temp. Rise (Min. - Max.) °F	30 - 60	30 - 60	35 - 65
AFUE (%) (c)	80	80	80
Return Air Temp. (Min. - Max.) °F	55°F - 80°F	55°F - 80°F	55°F - 80°F
BLOWER DRIVE	DIRECT	DIRECT	DIRECT
Diameter - Width (in.)	11 X 11	11 X 11	11 X 11
No. Used	1	1	1
Speeds (No.) (d)	CTM - 9	CTM - 9	CTM - 9
CFM vs. in. w.g.	See Fan Performance Table	See Fan Performance Table	See Fan Performance Table
Motor HP	1	1	1
R.P.M.	1050	1050	1050
Volts / Ph / Hz	120 / 1 / 60	120 / 1 / 60	120 / 1 / 60
FLA	10.9	10.9	10.9
COMBUSTION FAN - Type	PSC	PSC	PSC
Drive - No. Speeds	Direct - 2	Direct - 2	Direct - 2
Motor RPM	3300/2600	3300/2600	3300/2600
Volts/Ph/Hz	120 / 1 / 60	120 / 1 / 60	120 / 1 / 60
FLA	0.30	0.33	0.33
Inducer Orifice	1.80	2.50	2.15



Product Specifications

Model	S8X2C080M5PSC (a)	S8X2C100M5PSC (a)	S8X2D120M5PSC (a)
FILTER - Furnished?	No	No	No
Type Recommended	High Velocity	High Velocity	High Velocity
Hi Vel. (No.-Size-Thk.)	1 - 20 X 25 - 1 in.	1 - 20 X 25 - 1 in.	1 - 24 X 25 - 1 in.
VENT PIPE DIAMETER - Min. (in.) (e)	4 Round	4 Round	4 Round
HEAT EXCHANGER - Type	Aluminized Steel	Aluminized Steel	Aluminized Steel
Gauge (Fired)	20 - 19	20 - 19	20 - 19
ORIFICES - Main			
Nat. Gas Qty. - Drill Size	4 - 45	5 - 45	6 - 45
L.P. Gas Qty. - Drill Size	4 - 56	5 - 56	6 - 56
GAS VALVE	Redundant - Two Stage	Redundant - Two Stage	Redundant - Two Stage
PILOT SAFETY DEVICE - Type	120 V SiNi Igniter	120 V SiNi Igniter	120 V SiNi Igniter
BURNERS - QTY	4	5	6
POWER CONN. - V/Ph/HZ (f)	120 / 1 / 60	120 / 1 / 60	120 / 1 / 60
Ampacity (Amps)	14.1	14.1	14.1
Max. Overcurrent Protection (Amps)	15	15	15
PIPE CONN. SIZE (IN.)	1/2	1/2	1/2
DIMENSIONS	H x W x D	H x W x D	H x W x D
Uncrated (in.)	34 x 21 x 28.75	34 x 21 x 28.75	34 x 24.5 x 28.75
Crated (in.)	35.5 x 23 x 30.87	35.5 x 23 x 30.87	35.5 x 26.5 x 30.87
WEIGHT			
Shipping (Lbs.)/Net (Lbs.)	142 / 134	144 / 136	160 / 152

(a) Central Furnace heating designs are certified to ANSI Z21.47 - latest edition.

(b) For U.S. applications, above input ratings (BTUH) are up to 2,000 feet, derate 4% per 1,000 feet for elevations above 2,000 feet above sea level.

(c) Based on U.S. government standard tests

(d) 9 Speed constant torque ECM Blower Motor.

(e) Refer to the Installer's Guide.

(f) The above wiring specifications are in accordance with National Electric Code, however, installations must comply with local codes.



Airflow Tables

Furnace Airflow (CFM) Vs. External Static Pressure (in. W.C.)							
Model	Tap	Static	0.1	0.3	0.5	0.7	0.9
S8*1A026M2PSC	1	SCFM	437				
		Watts	29				
	2	SCFM	600	359	119		
		Watts	42	48	54		
	3	SCFM	650	435	219		
		Watts	47	56	65		
	4	SCFM	721	533	344	155	
		Watts	59	69	79	89	
	5	SCFM	936	782	629	475	321
		Watts	104	116	128	140	152
	6	SCFM	997	854	720	586	452
		Watts	123	136	149	162	175
	7	SCFM	1037	906	776	646	516
		Watts	137	151	165	178	192
	8	SCFM	1117	1000	883	766	650
		Watts	168	183	199	214	230
	9	SCFM	1251	1149	1048	946	845
		Watts	231	248	266	283	301

Furnace Airflow (CFM) Vs. External Static Pressure (in. W.C.)							
Model	Tap	Static	0.1	0.3	0.5	0.7	0.9
S8*1A040M3PSC S8X2A040M3PSC	1	SCFM	592	342	93		
		Watts	40	43	46		
	2	SCFM	666	467	268	70	
		Watts	48	56	65	74	
	3	SCFM	687	493	299	105	
		Watts	49	59	69	78	
	4	SCFM	938	788	638	488	338
		Watts	100	111	123	134	146
	5	SCFM	1006	870	733	597	461
		Watts	119	131	144	156	169
	6	SCFM	1068	944	820	696	573
		Watts	140	154	167	181	194
	7	SCFM	1174	1066	957	848	740
		Watts	181	196	211	226	241
	8	SCFM	1167	1098	1029	960	891
		Watts	194	219	244	269	294
	9	SCFM	1556	1474	1392	1310	1228
		Watts	398	416	435	453	471

Furnace Airflow (CFM) Vs. External Static Pressure (in. W.C.)							
Model	Tap	Static	0.1	0.3	0.5	0.7	0.9
S8*1B040M2PSC	1	SCFM	526				
		Watts	34				
	2	SCFM	744	533	322	110	
		Watts	54	63	72	81	
	3	SCFM	820	662	504	346	188
		Watts	68	81	94	106	119
	4	SCFM	967	811	654	498	341
		Watts	97	110	122	135	148
	5	SCFM	997	840	687	533	380
		Watts	104	116	129	142	154
	6	SCFM	1052	911	771	630	490
		Watts	119	133	148	162	176
	7	SCFM	1099	968	837	706	575
		Watts	134	150	165	180	196
	8	SCFM	1168	1047	926	805	684
		Watts	157	174	191	208	225
	9	SCFM	1303	1196	1088	981	874
		Watts	214	233	252	271	290

Furnace Airflow (CFM) Vs. External Static Pressure (in. W.C.)							
Model	Tap	Static	0.1	0.3	0.5	0.7	0.9
S8*1B060M4PSC S8X2B060M4PSC	1	SCFM	596	287			
		Watts	38	42			
	2	SCFM	851	667	483	299	115
		Watts	70	81	92	102	113
	3	SCFM	1142	1018	893	769	644
		Watts	141	156	172	187	203
	4	SCFM	1196	1079	961	844	726
		Watts	160	176	192	208	224
	5	SCFM	1362	1258	1154	1050	946
		Watts	220	239	257	276	294
	6	SCFM	1416	1319	1221	1124	1026
		Watts	250	269	288	307	327
	7	SCFM	1495	1402	1309	1216	1123
		Watts	287	307	327	347	367
	8	SCFM	1574	1487	1401	1314	1228
		Watts	337	357	378	399	420
	9	SCFM	1983	1899	1815	1730	1646
		Watts	659	670	680	691	701



Airflow Tables

Furnace Airflow (CFM) Vs. External Static Pressure (in. W.C.)							
Model	Tap	Static	0.1	0.3	0.5	0.7	0.9
S8*1B080M4PSC S8X2B080M4PSC	1	SCFM	552	160			
		Watts	34	34			
	2	SCFM	891	720	549	378	207
		Watts	82	93	105	117	129
	3	SCFM	1123	996	869	742	615
		Watts	141	157	173	189	205
	4	SCFM	1344	1240	1136	1033	929
		Watts	224	244	263	283	302
	5	SCFM	1479	1384	1290	1196	1102
		Watts	290	312	333	354	375
	6	SCFM	1583	1496	1408	1321	1234
		Watts	354	376	398	420	442
	7	SCFM	1654	1572	1491	1409	1327
		Watts	405	428	451	474	496
	8	SCFM	1818	1739	1661	1582	1503
		Watts	542	561	581	600	619
	9	SCFM	1926	1841	1756	1670	1585
		Watts	645	656	667	679	690

Furnace Airflow (CFM) Vs. External Static Pressure (in. W.C.)							
Model	Tap	Static	0.1	0.3	0.5	0.7	0.9
S8*1C080M5PSC S8X2C080M5PSC	1	SCFM	728	358			
		Watts	44	49			
	2	SCFM	809	540	271		
		Watts	53	63	74		
	3	SCFM	1440	1273	1105	938	770
		Watts	185	201	218	234	250
	4	SCFM	1536	1385	1233	1081	929
		Watts	220	238	257	275	293
	5	SCFM	1689	1552	1414	1277	1140
		Watts	278	299	320	342	363
	6	SCFM	1792	1661	1530	1400	1269
		Watts	326	348	371	394	417
	7	SCFM	1899	1771	1643	1515	1387
		Watts	373	397	422	446	471
	8	SCFM	2094	1985	1875	1766	1656
		Watts	500	527	554	582	609
	9	SCFM	2533	2414	2295	2176	2058
		Watts	931	932	933	933	934

Furnace Airflow (CFM) Vs. External Static Pressure (in. W.C.)							
Model	Tap	Static	0.1	0.3	0.5	0.7	0.9
S8*1C100M5PSC S8X2C100M5PSC	1	SCFM	821	442			
		Watts	55	55			
	2	SCFM	1359	1195	1031	868	704
		Watts	163	180	198	215	233
	3	SCFM	1602	1461	1321	1180	1040
		Watts	246	268	290	312	334
	4	SCFM	1807	1678	1550	1421	1292
		Watts	336	362	388	414	440
	5	SCFM	1827	1700	1572	1444	1317
		Watts	345	371	398	425	451
	6	SCFM	1925	1800	1675	1550	1425
		Watts	395	423	451	479	508
	7	SCFM	2102	1985	1869	1752	1635
		Watts	503	534	566	597	628
	8	SCFM	2222	2115	2008	1901	1794
		Watts	602	635	667	700	732
	9	SCFM	2458	2351	2245	2138	2032
		Watts	896	913	930	947	964

Furnace Airflow (CFM) Vs. External Static Pressure (in. W.C.)							
Model	Tap	Static	0.1	0.3	0.5	0.7	0.9
S8*1D120M5PSC S8X2D120M5PSC	1	SCFM	1469	912	355		
		Watts	184	126	68		
	2	SCFM	1429	1165	900	636	371
		Watts	175	171	168	164	160
	3	SCFM	1567	1401	1235	1069	903
		Watts	215	232	248	264	280
	4	SCFM	1858	1731	1605	1478	1351
		Watts	334	361	388	415	441
	5	SCFM	2004	1890	1776	1662	1548
		Watts	418	447	476	505	534
	6	SCFM	2110	2004	1898	1792	1686
		Watts	488	518	549	580	611
	7	SCFM	2245	2148	2052	1956	1860
		Watts	596	629	662	695	729
	8	SCFM	2440	2345	2250	2155	2060
		Watts	765	794	824	854	884
	9	SCFM	2536	2431	2325	2220	2114
		Watts	882	904	927	949	972



CFM Versus Temperature Rise

S8B1/S8X1 Furnaces have one stage heating

S8X2 Furnaces have two stage heating. First Stage is Low heating and Second Stage is High heating.

Table 2. S8B1/S8X1

Model	CFM Versus Temperature Rise																				
	400	500	600	700	800	900	1000	1100	1200	1300	1400	1500	1600	1700	1800	1900	2000	2100	2200	2300	2400
S8*1A026M2PSC	48	39	32																		
S8*1A040M3PSC		59	49	42	37	33	30	27													
S8*1B040M2PSC		59	49	42	37	33	30	27													
S8*1B060M4PSC					56	49	44	40	37	34	32										
S8*1B080M4PSC							59	54	49	46	42	40	37	35	33						
S8*1C080M5PSC							59	54	49	46	42	40	37	35	33						
S8*1C100M5PSC										57	53	49	46	44	41	39	37	35	34	32	31
S8*1D120M5PSC												59	56	52	49	47	44	42	40	39	37

Table 3. S8X2 – Low Heat

Model	CFM Versus Temperature Rise – First Stage (Low) Heating																
	400	500	600	700	800	900	1000	1100	1200	1300	1400	1500	1600	1700	1800	1900	2000
S8X2A040M3PSC	48	39	32	28													
S8X2B060M4PSC		56	47	40	35	31	28										
S8X2B080M4PSC				55	48	43	39	35	32	30	28						
S8X2C080M5PSC				55	48	43	39	35	32	30	28						
S8X2C100M5PSC					60	53	48	44	40	37	34	32	30				
S8X2D120M5PSC								57	52	48	44	41	39	37	35	33	31

Table 4. S8X2 – High Heat

Model	CFM Versus Temperature Rise – Second Stage (High) Heating																				
	400	500	600	700	800	900	1000	1100	1200	1300	1400	1500	1600	1700	1800	1900	2000	2100	2200	2300	2400
S8X2A040M3PSC		59	49	42	37	33	30	27													
S8X2B060M4PSC					56	49	44	40	37	34	32										
S8X2B080M4PSC							59	54	49	46	42	40	37	35	33						
S8X2C080M5PSC							59	54	49	46	42	40	37	35	33						
S8X2C100M5PSC										57	53	49	46	44	41	39	37	35	34	32	31
S8X2D120M5PSC												59	56	52	49	47	44	42	40	39	37

Wiring Diagrams

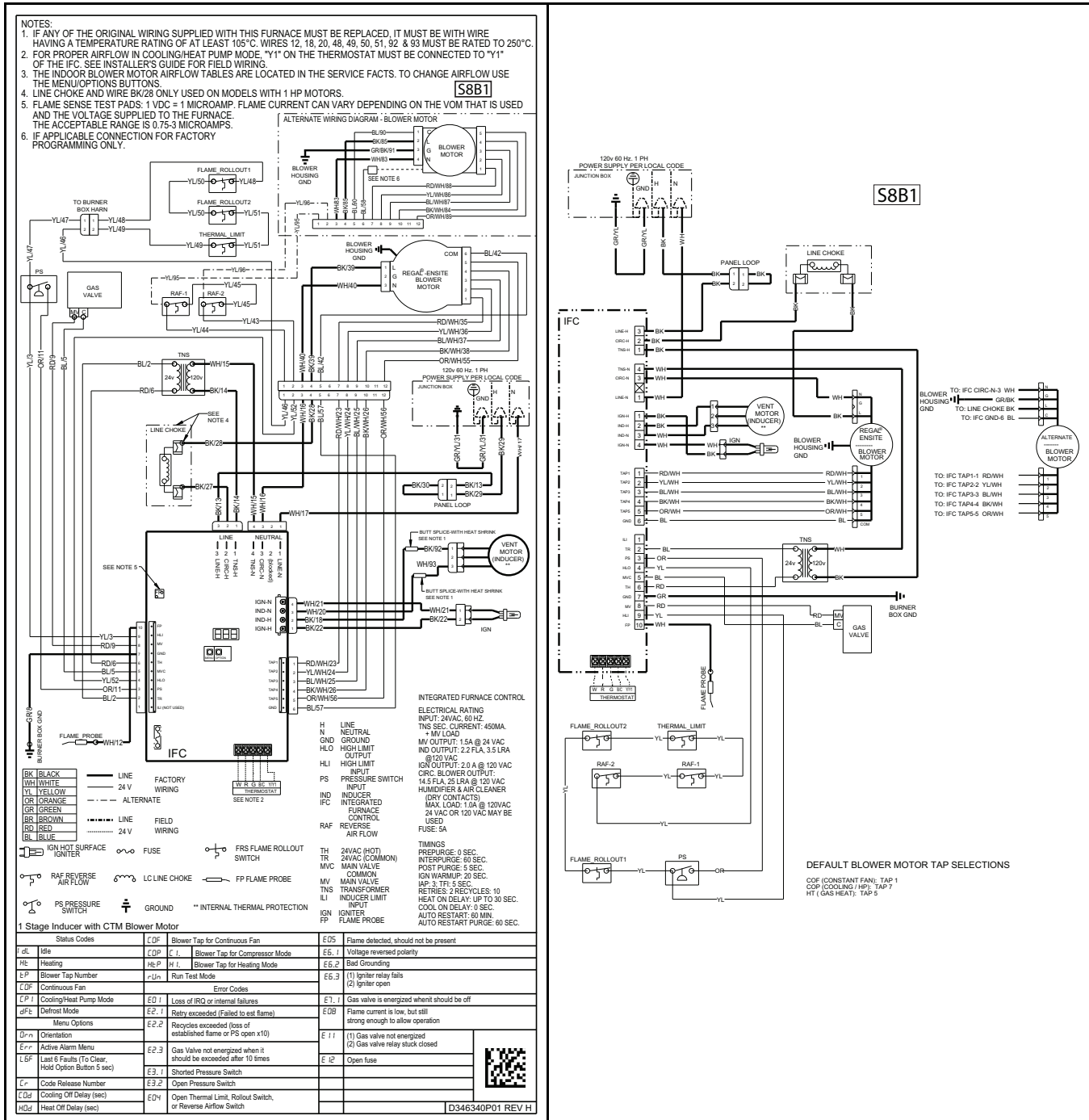

NOTES

1. IF ANY OF THE ORIGINAL WIRING AS SUPPLIED WITH THIS FURNACE MUST BE REPLACED, IT MUST BE WITH WIRE HAVING A TEMPERATURE RATING OF AT LEAST 105°C. WIRES 12, 18, 20, 48, 49, 50, 51, 92, 93 MUST BE RATED TO 250°C.
2. COOLING / HEAT PUMP SYSTEMS - Y1 AND/OR Y2 MUST CONNECT FROM THE THERMOSTAT TO THE IFC LOW VOLTAGE TERMINALS FOR PROPER AIRFLOW. SEE INSTALLER'S GUIDE FOR FIELD WIRING.
3. THE INDOOR BLOWER MOTOR AIRFLOW TABLES ARE LOCATED IN THE SERVICE FIELDS.
4. TO CHANGE AIRFLOW USE THE MENU/OPTIONS BUTTONS.
5. LINE CHOKE AND WIRE BK/28 ONLY USED ON MODELS WITH 1 HP MOTORS.
6. FLAME SENSE TEST PADS: 1 VDC = 1 MICROAMP. FLAME CURRENT CAN VARY DEPENDING ON THE VOM THAT IS USED AND THE VOLTAGE SUPPLIED TO THE FURNACE. THE ACCEPTABLE RANGE IS 0.75-3 MICROAMPS.

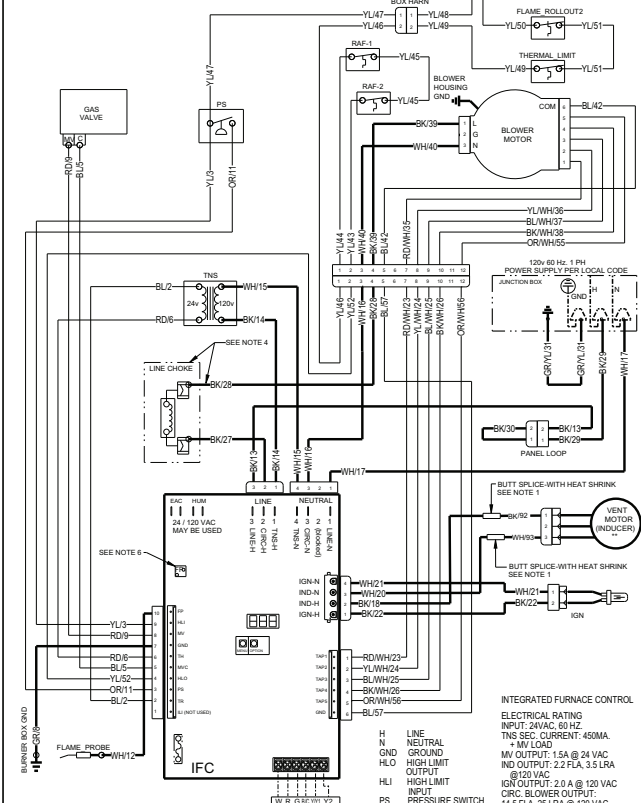

- INTEGRATED FURNACE CONTROL**
- ELECTRICAL RATING**
 INPUT: 24VAC, 60 HZ
 TNS SEC. CURRENT: 450MA
 + MV LOAD
 MV OUTPUT: 1.5A @ 24 VAC
 IND OUTPUT: 2.2 FLA, 3.5 LRA @ 120 VAC
 CIRC. BLOWER OUTPUT: 14.5 FLA, 25 LRA @ 120 VAC
 HUMIDIFIER & AIR CLEANER (DRY CONTACTS)
 MAX. LOAD: 1.6A @ 120VAC
 24 VAC OR 120 VAC MAY BE USED
 FUSE: 5A
- TIMINGS**
 PREPURGE: 0 SEC.
 INTERPURGE: 60 SEC.
 POST PURGE: 5 SEC.
 IGN WARMUP: 20 SEC.
 UP: 3 TR: 5 SEC.
 RETRIES: 2 RECYCLES: 10
 HEAT ON DELAY: UP TO 30 SEC.
 COOL ON DELAY: 0 SEC.
 AUTO RESTART: 60 MIN.
 AUTO RESTART PURGE: 60 SEC.

1 Stage Inducer with CTM Blower Motor

Status Codes	Heat Off Delay (sec)	E3.1	Shorted Pressure Switch
St. Idle	CDP Blower Tap for Continuous Fan	E3.2	Open Pressure Switch
Hk Heating	E1 Blower Tap for 1st Stage Compressor Mode	E0H	Open Thermal Limit, Rollout Switch, or Reverse Airflow Switch
L.P Blower Tap Number	E2 Blower Tap for 2nd Stage Compressor Mode	E0S	Flame detected, should not be present
CDP Continuous Fan	E1 Blower Tap for Heating Mode	E6.1	Voltage reversed polarity
CPJ Cooling Heat Pump Mode	E1 Blower Tap for Compressor Mode	E6.2	Bad Grounding
dFC Defrost Mode	E1 Run Test Mode	E6.3	(1) Igniter relay fails (2) Igniter open
Menu Options	U Error Codes	E7.1	Gas valve is energized when it should be off
D-m Orientation	E0.1 Loss of IRQ or internal failures	E0B	Flame current is low, but still strong enough to allow operation
Err Active Alarm Menu	E2.1 Retry exceeded (Failed to est flame)	E1.1	(1) Gas valve not energized (2) Gas valve relay stuck closed
L6F Last 6 Faults To Clear	E2.2 Recycles exceeded (loss of established flame of PS open x10)	E1.2	Open fuse
Cr Code Release Number	E2.3 Gas Valve not energized when it should be exceeded after 10 times		
CDJ Cooling Off Delay (sec)			
DdJ Outdoor Unit			

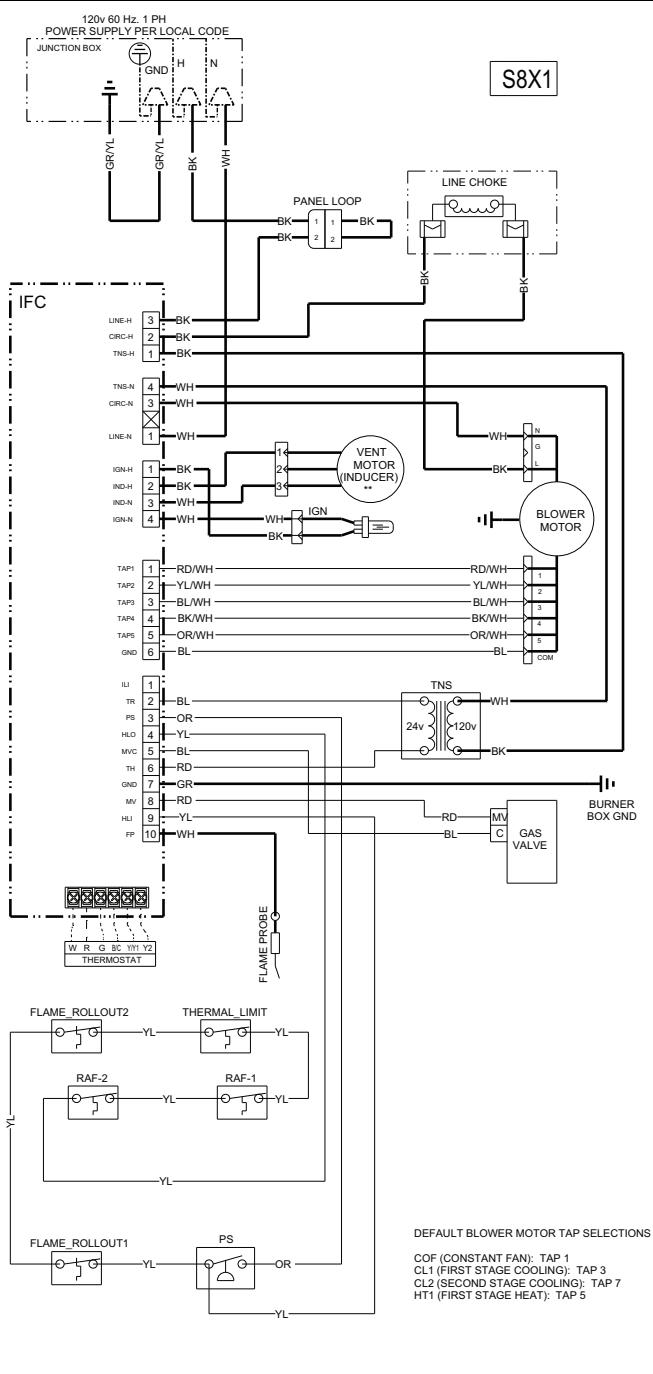

DEFAULT BLOWER MOTOR TAP SELECTIONS
 COF (CONSTANT FAN): TAP 1
 CL1 (FIRST STAGE COOLING): TAP 3
 CL2 (SECOND STAGE COOLING): TAP 7
 HT1 (FIRST STAGE HEAT): TAP 5

- NOTES:**
- IF ANY OF THE ORIGINAL WIRING AS SUPPLIED WITH THIS FURNACE MUST BE REPLACED, IT MUST BE WITH WIRE HAVING A TEMPERATURE RATING OF AT LEAST 105°C. WIRES 12, 18, 48, 49, 50, 51, 92, 93, AND 94 REQUIRE A TEMPERATURE RATING OF AT LEAST 250°C.
 - FOR PROPER AIRFLOW IN COOLING/HEAT PUMP MODES, Y1 AND/OR Y2 MUST CONNECT FROM THE THERMOSTAT TO THE IFC LOW VOLTAGE TERMINAL STRIP.
 - FOR COOLING ONLY SYSTEMS, LEAVE Y1-O JUMPER IN PLACE ON THE IFC FOR CORRECT LED READOUT.
 - FOR HEAT PUMP SYSTEMS, REMOVE THE Y1-O JUMPER, CONNECT 'O' FROM THE THERMOSTAT TO 'O' ON THE IFC LOW VOLTAGE TERMINAL STRIP FOR CORRECT LED READOUT.
 - IF USING A SINGLE STAGE HEATING THERMOSTAT, JUMPER W1 AND W2 TERMINALS AT THE LOW VOLTAGE TERMINAL STRIP. HTZ WILL BE SHOWN ON THE SEVEN SEGMENT DISPLAY AT ALL TIMES. SECOND STAGE OPERATION WILL BEGIN AFTER THE INTERSTAGE DELAY HAS COMPLETED.
 - AIRFLOW TABLES ARE LOCATED IN THE SERVICE FACTS. TO CHANGE AIRFLOW, REFER TO THE INTEGRATED FURNACE CONTROL MENU AND OPTIONS TO SET AIRFLOW AND BLOWER DELAYS.
 - LINE CHOKE AND WIRE BK28 ONLY USED ON MODELS WITH 1 HP MOTORS.
 - WIRE YL45 AND RAF-2 ARE NOT PRESENT ON DOWNFLOW MODELS.
 - FLAME SENSE TEST PADS: 1 VDC = 1 MICROAMP. FLAME CURRENT CAN VARY DEPENDING ON THE VOM THAT IS USED AND THE VOLTAGE SUPPLIED TO THE FURNACE. THE ACCEPTABLE RANGE IS 0.75-3 MICROAMPS.

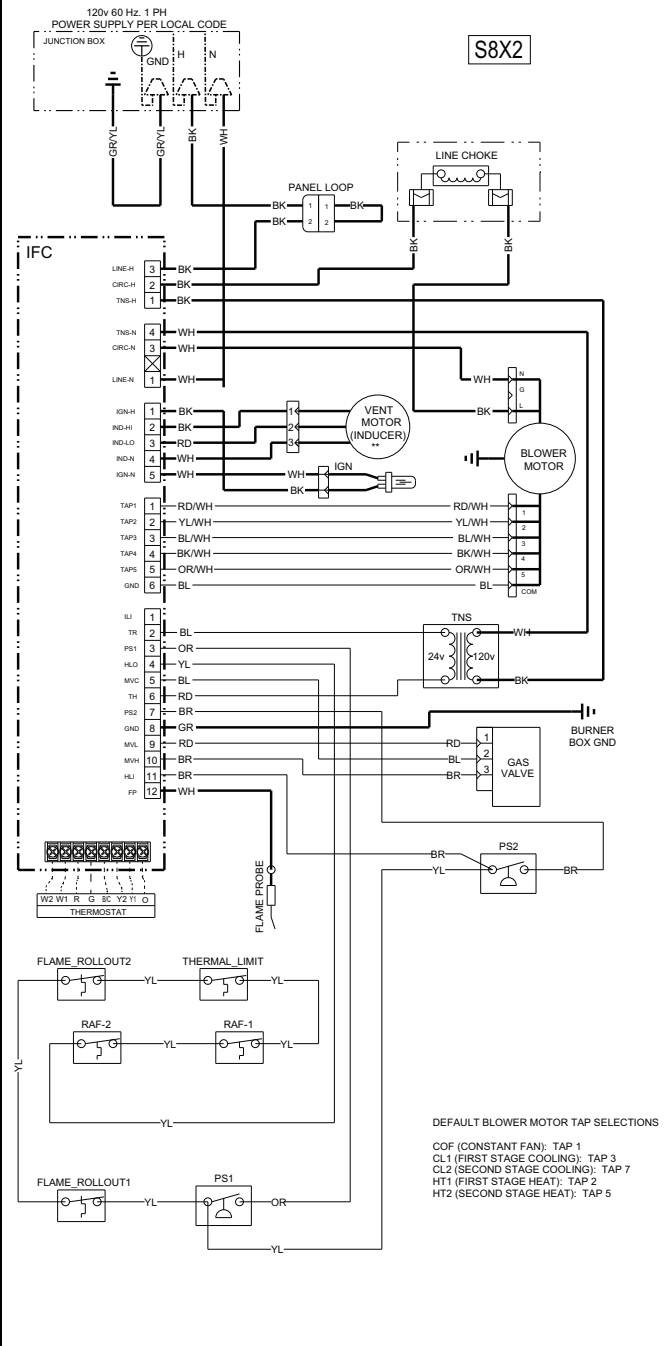
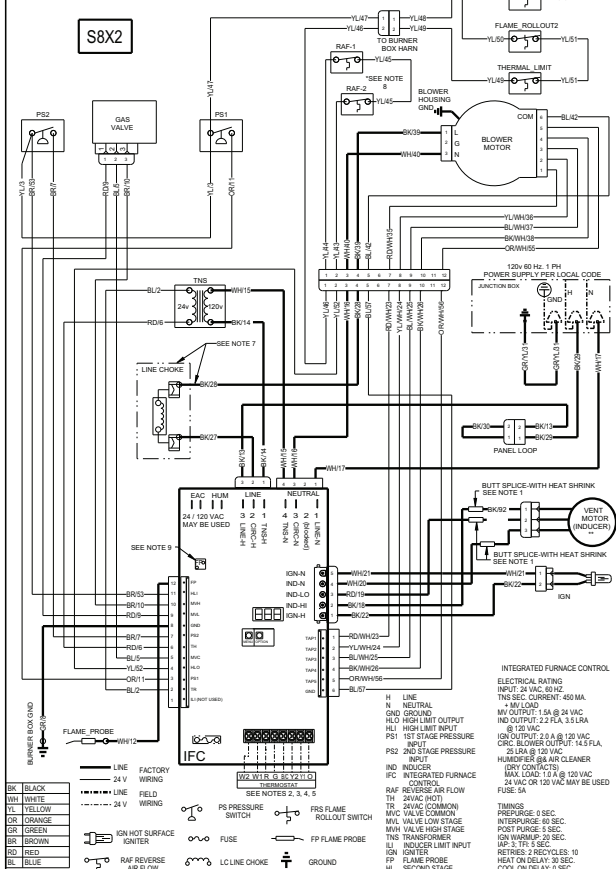



Electrical Connections

Make wiring connections to the unit as indicated on enclosed wiring diagram. As with all gas appliances using electrical power, this furnace shall be connected into a permanently live electric circuit. It is recommended that furnace be provided with a separate "circuit protection device" electric circuit. The furnace must be electrically grounded in accordance with local codes or in the absence of local codes with the National Electrical Code, ANSI/NFPA 70, if an external electrical source is utilized. **The integrated furnace control is polarity sensitive.** The hot leg of the 120V power supply must be connected to the black power lead as indicated on the wiring diagram. Refer to the SERVICE FACTS literature and unit wiring diagram attached to furnace.

Field Wiring

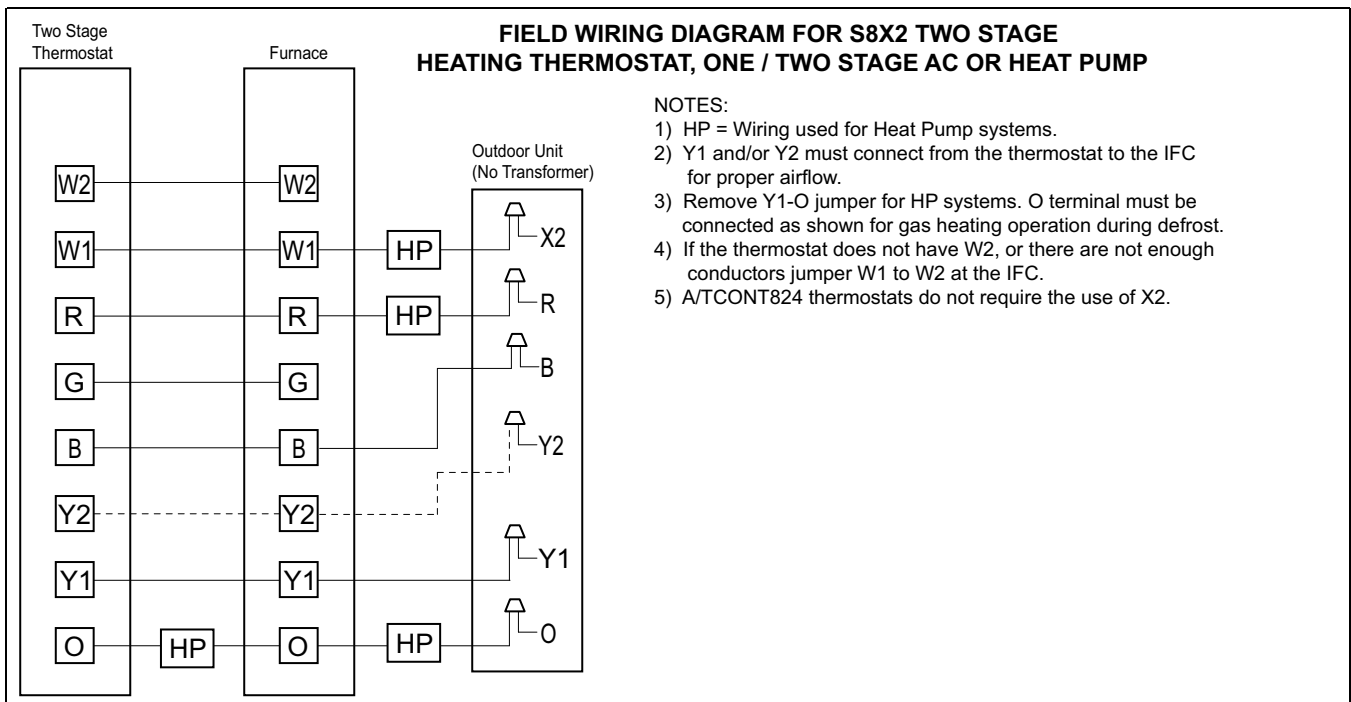
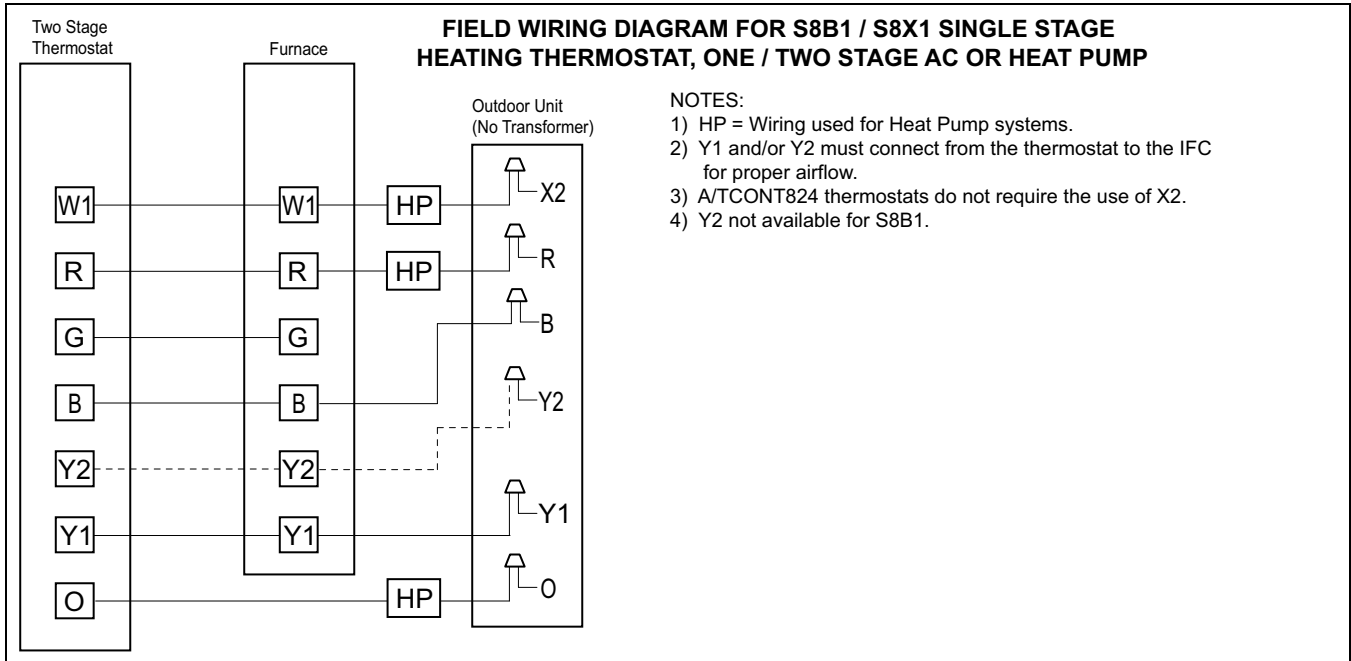

Outline Drawing

Table 5. 14.5" Width Cabinet

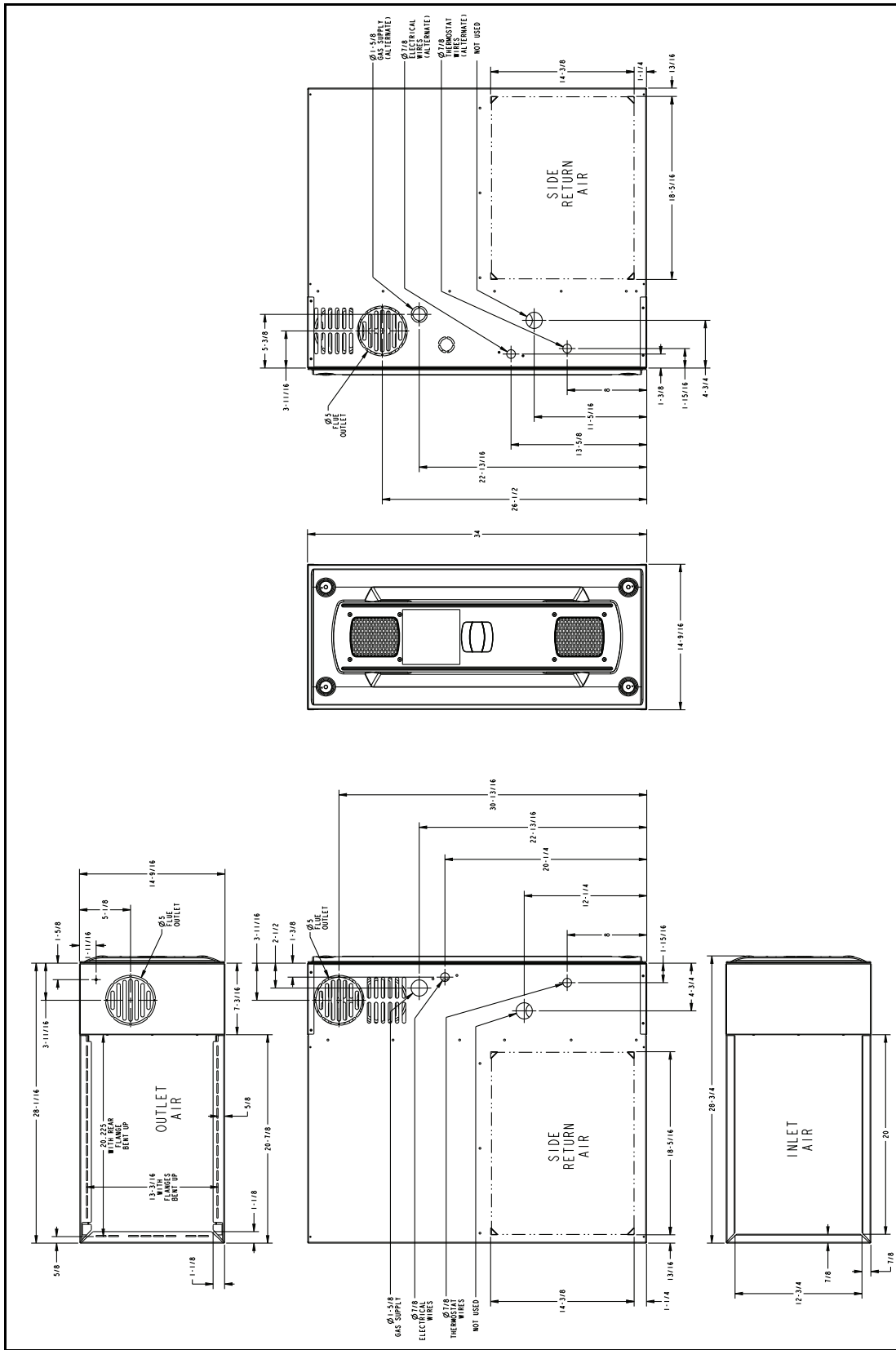

Table 7. 21.0" Width Cabinet

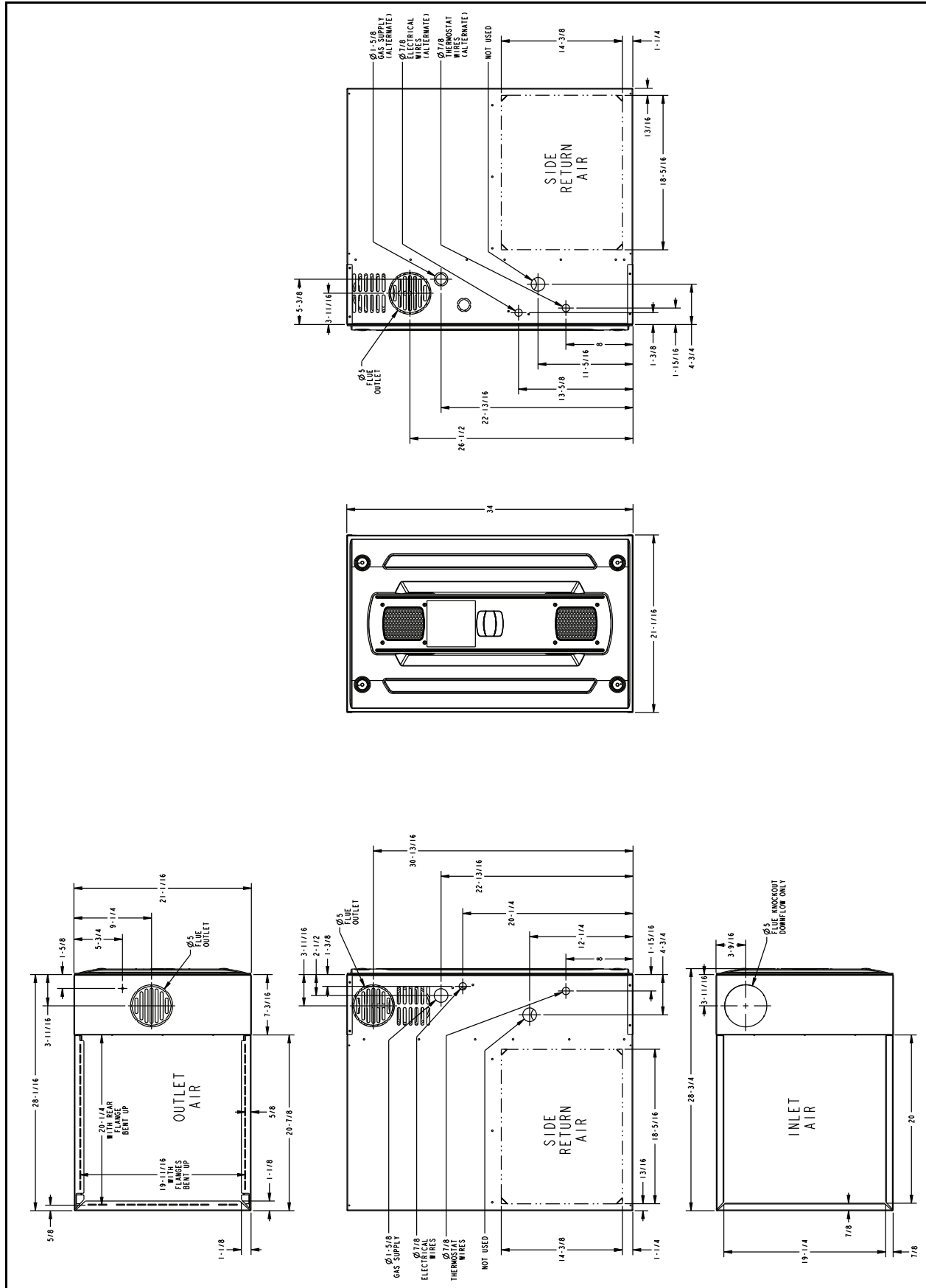
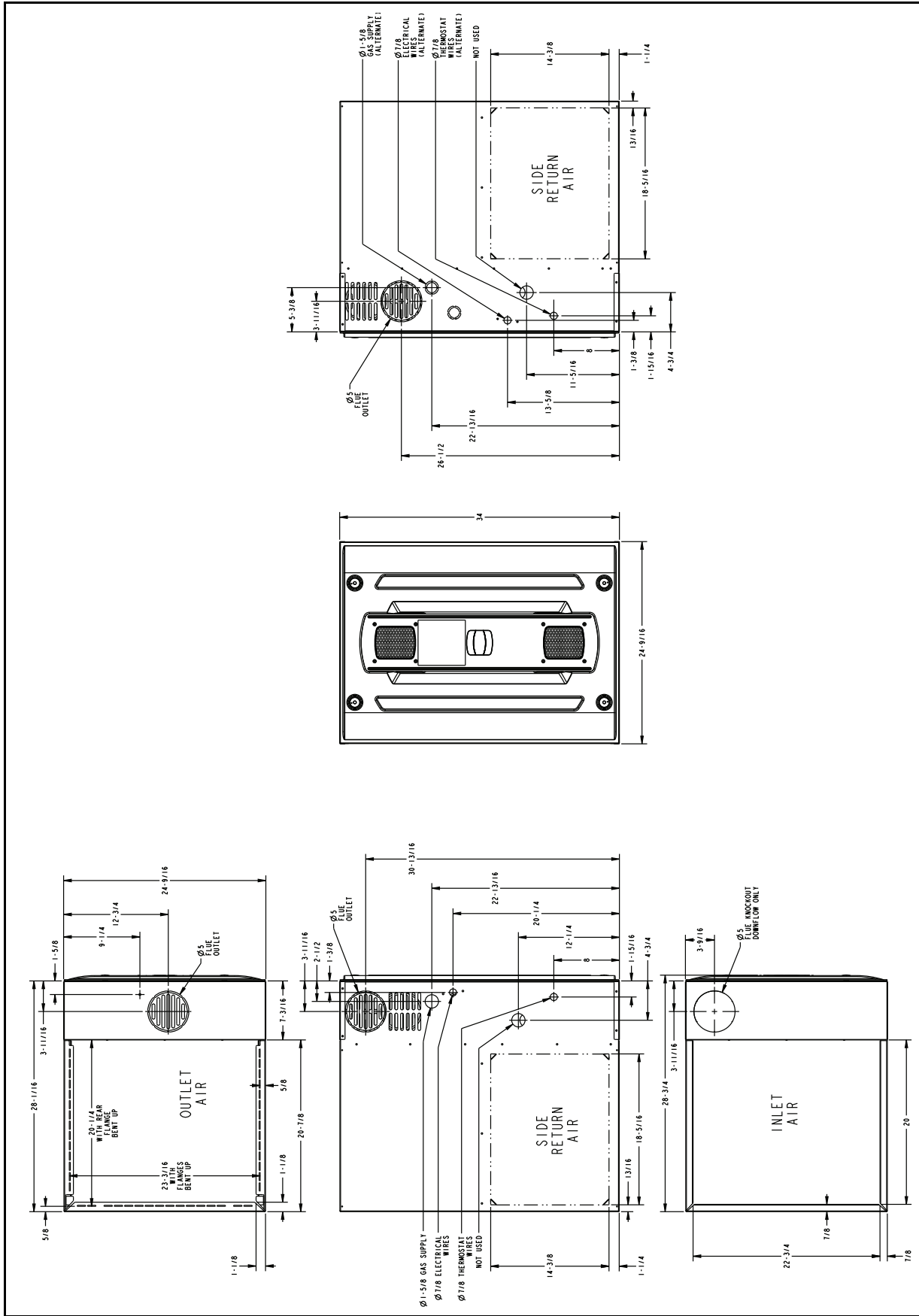

Table 8. 24.5" Width Cabinet





Trane - by Trane Technologies (NYSE: TT), a global innovator - creates comfortable, energy efficient indoor environments for commercial and residential applications. For more information, please visit trane.com or tranetechnologies.com.



Trane has a policy of continuous data improvement and it reserves the right to change design and specifications without notice. We are committed to using environmentally conscious print practices.