

# vive®

# WIRELESS CHAIR SENSOR PAD

User Manual  
LVA1074CHR

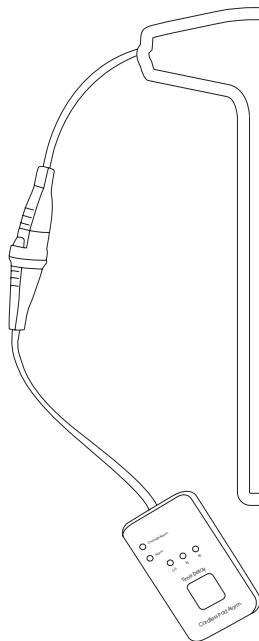

## vive® vivehealth.com

### Wireless Chair Sensor Pad

#### SETTING UP THE SENSOR PAD

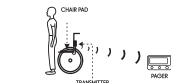

1. Write the start date and expiration date on the pad with a permanent marker. The usable life of this pad is 365 days.

2. Connect the transmitter to the sensor pad.

3. Place the sensor pad on the desired location. Make sure the transmitter is mounted where the caregiver can access it conveniently.

4. Proceed to programming your transmitter to your wireless pager if not already complete.

#### PROGRAMMING THE TRANSMITTER TO A WIRELESS PAGER

On the pager, press and hold both UP and DOWN arrows for 3 seconds. You will see the number "1" flashing in red, indicating that the pager is now in programming mode.

2. There are 10 channels on the pager for programming up to 10 individual wireless devices. Select a number for programming by pressing the UP or DOWN arrow on the front of the pager.

3. While the pager is in paging mode, a red light should flash over the device number (P1-P10) that you are attempting to pair the alarm with. While this light is

flashing, press the button on the transmitter once to select it up, then hold for 3 seconds until the alarm light on the transmitter flashes orange. Then release the button on the transmitter.

4. The pager will beep to signal a successful connection. Then it will re-enter programming mode in case you need to connect other wireless devices. If you do not need to connect more devices press and hold both the UP and DOWN arrows on the front of the pager to exit programming mode.

5. Test the connection by sitting down on the sensor pad and standing up. The alarm should sound on the pager and the connected channel number should flash in red while the alarm sounds. To silence the alarm press the STOP button on the pager. If it does not occur follow these steps again from the beginning or contact us for help.

#### ADJUSTING THE TRANSMITTER TIME DELAY

Press and release the time delay button on the front face of the transmitter until desired time delay setting is selected. Options are 0 seconds, 2 seconds and 4 seconds.

Note: This function can reduce false alarms if the patient momentarily falls off the pad and then locks onto the pad within the set delay time.

#### CHANGING THE PAD

The usable life of this sensor pad is 365 days. For safety reasons, periodically check the expiration date on the sensor pad and replace the sensor pad as necessary.

To replace the sensor pad, remove the transmitter from the pad and connect the transmitter to the cord of the new sensor pad.

For safety reasons, periodically check the expiration date on the transmitter and replace transmitter when necessary.

When the sensor pad transmitter needs replacing, the red "Change Alarm" LED on the face of the transmitter will begin flashing.

#### CAUTION

- The transmitter and sensor pad should be checked prior to each use.
- SHARP BENDS OR FOLDING THIS PAD WILL CAUSE

#### REPAIRABLE DAMAGE:

- Keep the sensor pads flat at all times.
- Do not use the sensor pad if it has been immersed in liquid.

#### TROUBLESHOOTING

If your system does not properly function, please follow the steps below:

- Inspect your transmitter and pager. Change batteries if there's a "battery low" light and change your transmitter if there's a "Change Alarm" light.
- Check that the sensor pad is properly plugged into transmitter.
- Check and double on the sensor pad and transmitter, replace if necessary.

This sensor pad is antimicrobial and latex free.

#### Cleaning Instructions

- Use disinfectant wipe or antibacterial solution on a soft cloth to clean the exterior sensor pad.
- Do not fold or immerse in liquid.

#### WARNINGS ⚠

- This pad may not work with patients under 60 lbs.
- Test this pad with each new patient before use. Failure to do so could result in a fall and serious injury.
- Failure to replace the pad and transmitter in a timely manner could result in a fall and serious injury.
- The pager is able to communicate up to 150 feet away from the patient/resident in an open field. The actual communication distance (wireless range) in each building may vary. Test the actual wireless range in your building prior to putting the system into service and always keep the pager located within the wireless range.

#### SENSOR PAD IS VALID FOR 1 YEAR

START DATE:  EXPIRATION DATE:

www.vivehealth.com  
© 2014 Vive Health, Inc. All rights reserved.  
 10000 10th Ave, Suite 4, Austin, TX 78758  
 512.453.8888  
 1-800-368-3688  
 10000 10th Ave, Suite 4, Austin, TX 78758

vivehealth.com

## USER GUIDE

The Vive chair sensor pad is designed to alert caregivers of falls or unwanted movement by sounding an alert whenever pressure is removed from the sensor pad. The sensor pad can be placed on a chair or in a wheelchair to provide security and peace of mind that no movement goes unnoticed.

## SETTING UP THE SENSOR PAD

**Step 1:** Write the in-use date and expiration date on the pad with a permanent marker. The usable life of this pad is 365 days.

**Step 2:** Connect the transmitter to the sensor pad.

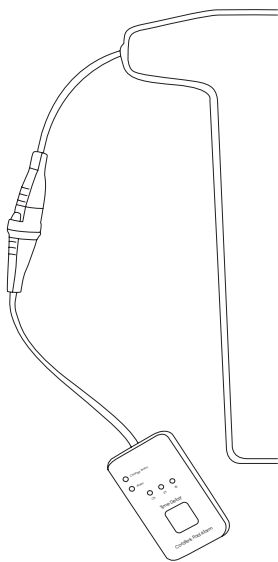

**Step 3:** Place the sensor pad on the desired location. Make sure the transmitter is mounted where the caregiver can access it conveniently.

**Step 4:** Proceed to programming your transmitter to your wireless pager if not already complete.

## PROGRAMMING THE TRANSMITTER TO A WIRELESS PAGER

**Step 1:** Open the battery door of the pager and insert two AA batteries as shown. Close the battery door.

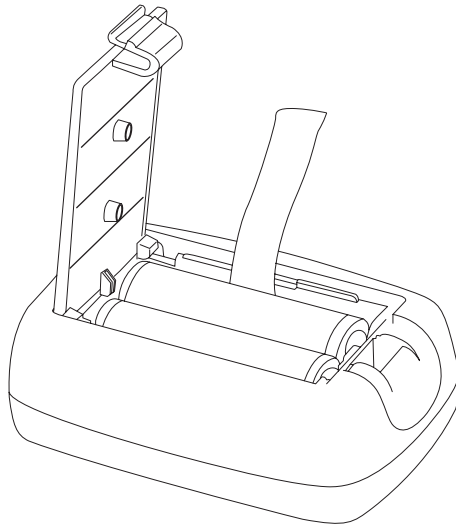

**Step 2:** On the pager, press and hold both UP and DOWN arrows for 5 seconds. You will see the number "1" is blinking in red, indicating that the pager is now in programming mode.

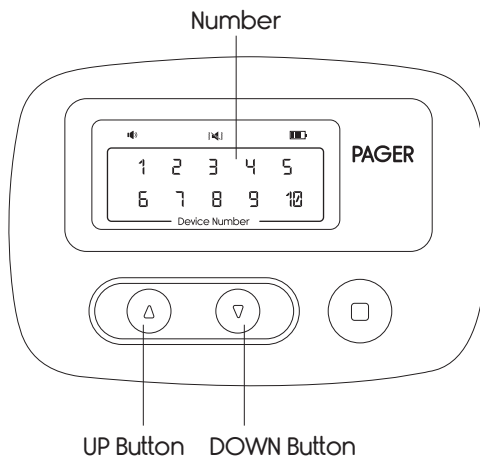

**Step 3:** There are 10 channels on the pager for programming up to 10 individual wireless devices. Select a number for programming by pressing the UP or DOWN arrow on the front of the pager.

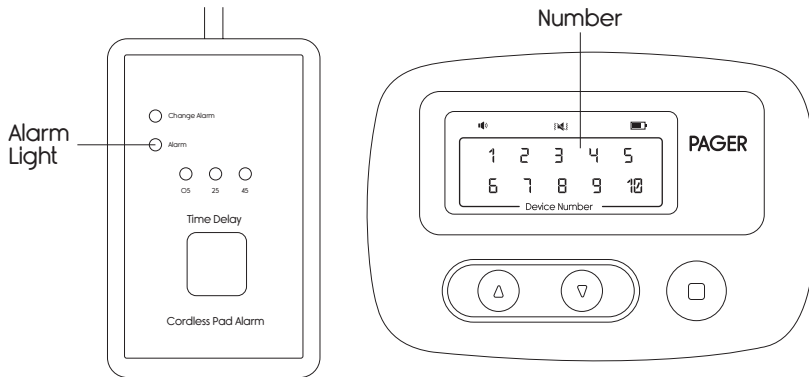

**Step 4:** While the pager is in pairing mode, a red light should flash over the device number (#1-10) that you are attempting to pair the alarm with. While this light is flashing, press the button on the transmitter once to wake it up, then hold for 5 seconds until the alarm light on the transmitter flashes orange. Then release the button on the transmitter.

**Step 5:** The pager will beep to signal a successful connection. Then it will re-enter programming mode in case you need to connect other wireless devices. If you do not need to connect more devices press and hold both the UP and DOWN arrows on the front of the pager to exit programming mode.

**Step 6:** Test the connection by sitting down on the sensor pad and standing up. The alarm should sound on the pager and the connected channel number should flash in red while the alarm sounds. To silence the alarm press the STOP button on the pager. If this does not occur follow these steps again from the beginning or contact us for help.



**Note:** The wireless pager sounds the alerts given from the sensor pad. The pager is sold separately.

## NOTIFICATION MODES FOR THE WIRELESS PAGER



### Step 1: Set notification mode for the WPG

The WPG has three notification modes.

Notification Mode	Notification	Sign
Audible notification	Beeps	🔊
Vibration notification	Vibration	📳
Audible + Vibration notification	Audible and Vibration	🔊 📳

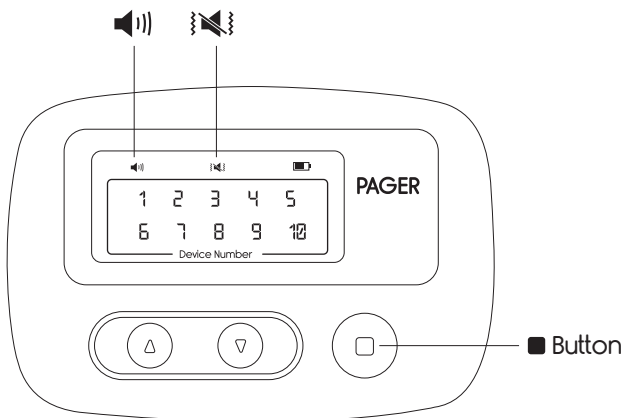
To set the notification modes, press and hold down both  Button on the front of the WPG for more than 5 seconds until the  image is blinking.



To select another notification mode, press and release the UP Button or DOWN Button on the front of the WPG. The next notification light  will start blinking. Continue to press and release the Up or Down buttons until the desired notification light is selected. Once you've landed on your desired notification light, press and release the  Button, you will hear a 1 second beep and/or feel a 1 second vibration. This means the current notification mode is recorded to the WPG.

**Step 2: Exit programming mode:** Press and hold both the UP and Down

buttons on the WPG for more than three seconds until you see the number light turn off. The WPG has now exited programming mode.

## ADJUSTING THE TRANSMITTER TIME DELAY

Press and release the time delay button on the front face of the transmitter until desired time delay setting is selected. Options are 0 seconds, 2 seconds and 4 seconds.

Note: This function can reduce false alarms if the patient momentarily shifts off the pad and then back onto the pad within the set delay time.

## TEST THE CHAIR ALARM TRANSMITTER

It is important to test the chair alarm before using with a patient. To test, apply pressure on the chair pad and release. If working correctly, the alarm light will flash one time and the programmed receiving devices will alarm. Press the button on the front of each receiving device to silence alarm.

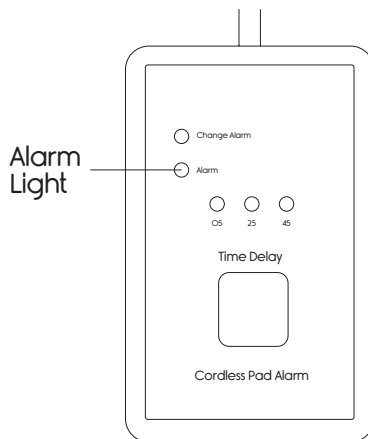

## CHANGING THE TRANSMITTER

The usable life of this chair alarm transmitter is 24 months. Actual life depends on how frequently the transmitter is used. When the transmitter needs

replacing, the red "Change Alarm" light will flash. To replace the transmitter, remove the transmitter from the pad and connect a new transmitter to the pad.

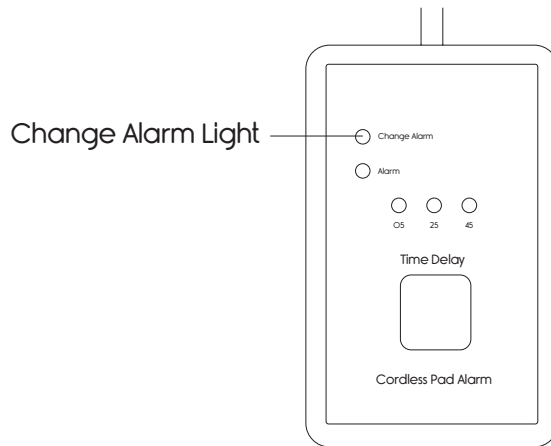

## WARNINGS

This device will not prevent a fall or injury. It is a supplemental part of an overall fall management program.

Failure to follow all product instructions may result in the failure or improper function of the product.

The WPG is able to communicate up to 150 feet away from the patient in open field. The actual communication distance or wireless range will vary from building to building. Test the wireless range in your building prior to putting the system into service. Always keep the pager located within the wireless range.

The pad, transmitter and any other devices should be checked prior to each use for proper functioning.

## TROUBLESHOOTING

When your system is not properly functioning, please follow these steps.

Step 1. Change the batteries if the "Change Alarm" light is lighted

Step 2: Change the transmitter if the "Change Alarm" light is lighted.

Step 3. Check that the pad is properly plugged into transmitter

Step 4: Check on how long the WPG and the pad have been in use. They may have run out of usual life.

Step 5: To determine which piece of equipment is at fault, follow the steps below:

- a. Take a new working transmitter and connect with the original pad.
- b. If the system works properly, the problem is with the original transmitter.
- c. If the system still does not work properly, the problem is with the original pad.



# ACTIVATE YOUR GUARANTEE



You are protected by Vive Health's industry leading guarantees and customer service:

If you did not purchase through [vivehealth.com](https://vivehealth.com), please register at [vivehealth.com/register](https://vivehealth.com/register) to validate your guarantee.

**Product Code: LVA1074CHR**

✉ [service@vivehealth.com](mailto:service@vivehealth.com)

☎ 1-800-487-3808  
Monday - Friday 9am - 5pm EST