

vive[®]
PRECISION



**BLOOD PRESSURE MONITOR
COMPATIBLE WITH
SMART DEVICES**

Owner's Manual
DMD10A7

vivehealth.com

INTRODUCTION

Thank you for purchasing the Vive Precision Blood Pressure Monitor Compatible with Smart Devices. With proper care and use, your monitor will provide you with many years of reliable readings.

The device is easy-to-use and good for home users and healthcare professionals. It applies the non-invasive oscillometric method which can measure your blood pressure and pulse rate quickly and easily, and it saves the data automatically to let you review the average and measured data at any time.

Automatic digital blood pressure monitors use the oscillometric method to electronically measure your blood pressure. The monitor detects your blood's movement through the artery in your arm and converts the movements into a digital reading. The oscillometric method does not require a stethoscope, making the monitor ideal for home use.

Blood pressure readings determined with the device are equivalent to measurements obtained by a trained healthcare professional using the cuff/stethoscope auscultation method, within the limits prescribed by the American National Standard for Electronic or Automated Sphygmomanometers.

We are constantly answering questions and recording helpful videos to make using your Vive Precision Blood Pressure Monitor Compatible with Smart Devices as easy as possible. Check out the included links and QR codes to help you through the process.



To see all FAQs in one place
visit vhealth.link/olu

INDICATIONS FOR USE

This device is for use by medical professionals or home users. It is intended to measure the systolic and diastolic blood pressure on an adult individual by using a non-invasive technique, in which an inflatable cuff is wrapped around the upper arm.

COMPLIANCE



This device conforms to European Medical Device Directive 93/42/EEC.







This device complies with:

- EN ISO 81060 standard relating to non-invasive sphygmomanometers
 - Part 1: Requirements and test methods for non-automated measurement types and EN 1060 standard relating to non-invasive sphygmomanometers.
 - Part 3: Supplementary requirements for electro-mechanical blood pressure measuring systems.

- EN 60601 standard relating to medical electrical equipment
 - Part 1-2: General requirements for basic safety and essential performance - Collateral standard: Electromagnetic compatibility - Requirements and tests.
- EN 1060-4:2004 standard relating to non-invasive sphygmomanometers
 - Part 4: Test procedures to determine the overall system accuracy of automated non-invasive sphygmomanometers.
- ISO 81060-2:2013 standard relating to non-invasive sphygmomanometers
 - Part 2: Clinical validation of automated measurement type.
- IEC 80601-2-30:2009+A1:2013 standard relating to medical electrical equipment
 - Part 2-30: Particular requirements for the basic safety and essential performance of automated type non-invasive sphygmomanometers.

SYMBOLS

Symbol	Function/Meaning
	WARNING/ATTENTION Indicates a potentially hazardous situation which, if not avoided, could result in death or serious injury.
	PRECAUTION/IMPORTANT INFORMATION

SN	Serial Number
	Manufacturer
	Type BF: Device, cuff and tubing are designed to provide special protection against electrical shocks.
SYS	Systolic Blood Pressure in mmHg
DIA	Diastolic Blood Pressure in mmHg
PUL	Pulse
	ED Directive Medical Device Label
	WEEE label
	Refer to instruction manual/booklet
	Keep dry

DEVICE DESCRIPTION



For a video demonstration,
check out: vhealth.link/xp4

Main Unit

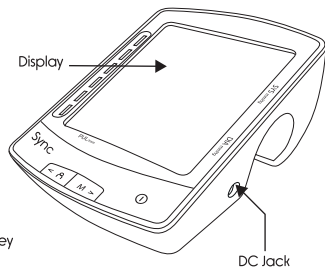
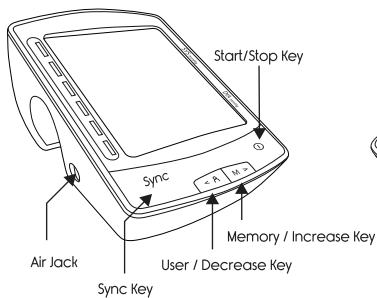

Arm Cuff

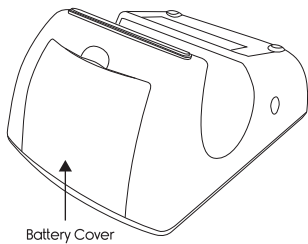
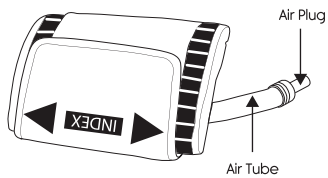

Information on the Display :

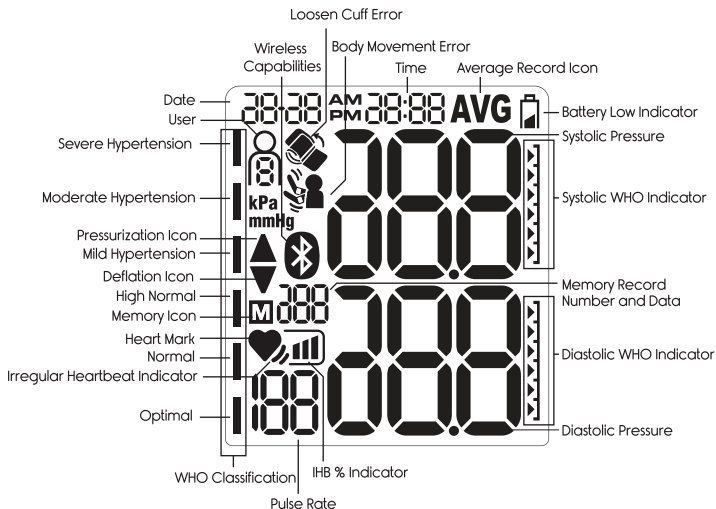

INSTALLING THE BATTERIES

1. Remove the battery cover.



2. Remove the used batteries and insert new batteries.

- a. Use AA alkaline batteries.
- b. Make sure the battery polarities (+) and (-) match the markings on the battery compartment.



- c. Insert the batteries starting with the bottom-most battery slot.

3. Close the battery cover.

Battery Level Indicator

When the battery level is getting low, the low battery symbol and "E6" will appear on the display. Replace all used batteries with new batteries.

Battery Specific Warnings and Precautions

Batteries may cause a choking hazard to children. Store the batteries out of the reach of children.

In case battery fluid leaks, do not touch the battery fluid. Avoid skin contact (e.g. put on protective gloves) and clean the battery compartment with dry cloth.

Remove the batteries from the battery compartment if the device will not be used for a long period.

Use only 1.5V alkaline batteries. Do not use other types of batteries, such as rechargeable batteries. This may damage the device.

Replace all batteries at the same time. Do not mix used and new batteries. Use of same brand and model of batteries is recommended.

Battery life may vary with ambient temperature and may be shorter at low temperature.

USE THE AC ADAPTER

1. Connect the AC adapter to the device
 - a. Insert the AC adapter output plug into the DC jack on the right side of the main unit.
 - b. Plug the AC adapter into an AC outlet.
 - c. The device will turn on and enter date and time setting mode. See the "Set the Pressure Unit / Date / Time / Smart Phone Connection" for instructions on how to do this.
2. Disconnecting the AC adapter from the device
 - a. Unplug the AC adapter from the AC outlet.
 - b. Remove the AC adapter output plug from the DC jack of the main unit.

AC Adapter Specific Warnings and Precautions

- Use AC adapter which complies with the requirements of IEC 60601-1 standard.
- Use only the authorized AC adapter specified by dealers. Other AC adapters may vary in output voltage and polarities, and may cause harm to the user or damage the device.
- Make sure that the AC adapter input voltage and plug type is matching the outlet voltage and type before connecting.
- Do not plug or unplug the AC adapter to the electrical outlet with wet hands.
- When the AC adapter is in use, the main unit does not draw power from the batteries.

SET THE PRESSURE UNIT / DATE / TIME / SMART PHONE CONNECTION

1. When new batteries are installed

- a. "mmHg" will blink on the display. Press M to select between "mmHg" and "kPa" to set the pressure unit.

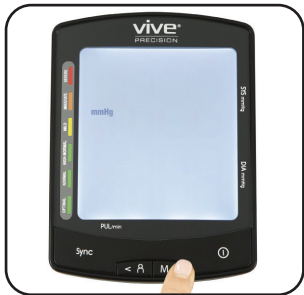

- b. Press sync key to confirm and then "YEAR" will start to blink. Press m+ or user - to set the current year.



- c. Press sync key to confirm and then "MONTH" will start to blink. Press or key to set the current Month.



- d. Press sync key to confirm and then "DAY" will start to blink. Press or key to set the current Day.



- e. Press sync key to confirm and then "HOUR" will start to blink. Press or key to set the current Hour.



- f. Press sync key to confirm and then "MINUTE" will start to blink. Press or key to set the current Minute.



- g. Press sync key to confirm and then phone icon will start to blink. Press or key to turn the smart phone connection on or off.



- h. Press power button to confirm and setting is completed.

BEFORE TAKING A MEASUREMENT

- Before using the device, check your upper arm circumference and make sure it matches the cuff circumference range.
- Keep record of your blood pressure and pulse rate. A single measurement does not provide an accurate indication of your true blood pressure.
- To ensure comparable data, measure your blood pressure at the same time of the day for consistency.
- Measurement should be taken in a quiet and comfortable indoor environment.
- To ensure a reliable measurement, follow these recommendations:
 - Avoid eating, drinking alcohol or caffeinated beverages, smoking, exercising, or bathing for 30 minutes before taking a measurement.
 - Rest for at least 5 minutes before taking measurements during stressful conditions.
 - Avoid taking measurement while you are physically tired or exhausted.
 - Remain still and do not talk during the measurement.
 - Position the cuff at heart level throughout the measurement.
- Relax and sit comfortably on a chair. Lay your feet flat on the floor. Do not cross your feet. Keep your back straight.

APPLYING THE ARM CUFF

1. Bare your left upper arm. Make sure that the blood circulation in your arm is not constricted by any clothing that is too tight.
2. Put your left arm through the cuff loop. Turn your palm upward. Position the cuff approximately $\frac{1}{2}$ inch or 1-2cm above your elbow. The air tube runs down the inside of the arm and aligns with the middle finger. Do not place the arm cuff over any clothing such as a sleeve.
3. Pull the end of the cuff and fasten the velcro. Make sure that the cuff is wrapped firmly around your upper arm, but should not constrict blood circulation.
4. Place your elbow steadily on a table or at a position so that the cuff is level with your heart.
5. Insert the cuff air plug into the air jack of the main unit. Make sure that the air plug is securely inserted.

PERFORMING BLOOD PRESSURE MEASUREMENT

1. Press the power button to activate the device.
2. Press the user button to select user memory 1, 2, 3, or 4. Confirm selection by pressing the power button. Then press the power button to start the measurement.
3. The cuff starts to inflate. It is normal for the cuff to feel very tight. A pressure bar indicator is displayed during measurement.

- Once the pulse is detected, the blinks with each pulse beat indicating that the measurement is in progress.
- When the measurement is complete, the systolic and diastolic pressure and pulse rate are displayed and stored.

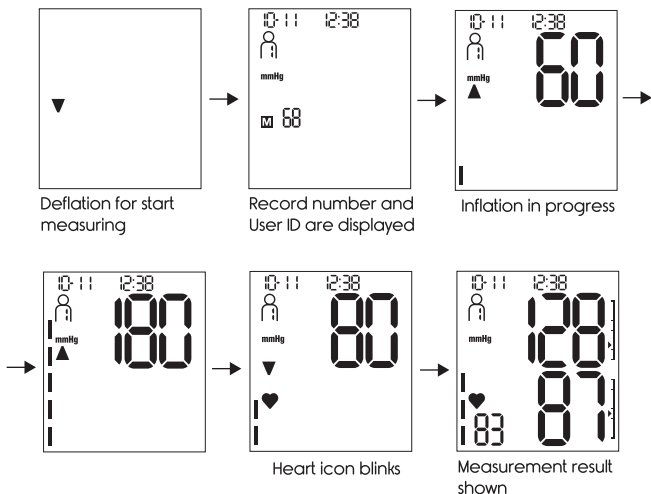

RECALL AVERAGE AND PREVIOUS MEASUREMENT DATA

The device has a memory capability to store the measurement data for up to 4 users - User 1, 2, 3, and 4. Every time you complete the measurement, the device automatically stores the measurement result. You can view the average data of all previous measurement data in the memory, and the AM/PM average data of the measurement data from the last 7 days.



For a video demonstration,
check out: vhealth.link/nfd

1. Press the M button in standby mode to enter the memory mode. The average value of all measurements of the selected user will display.
2. Press the M button to view average data for last 7 days AM record (5:00 - 9:00 am).
3. Press the M button to view average data for last 7 days PM record (6:00 - 8:00 pm).
4. Press the M button to view the latest measurement record.
5. Continue to press the M button to view older measurement records.
6. Press the M button to view previous measurement records.

DELETE MEASUREMENT DATA

While you are viewing the average or previous measurement data of the selected user:

1. Press and hold the and keys for about 5 seconds until 'CL' and 'OO' appear on the display. All measurement data memories of the selected user are deleted.
2. The device returns to Clock Mode.

TRANSFER MEASUREMENT DATA TO SMART DEVICE

1. Ensure that you have downloaded the free “Vive Precision” app onto your smart device.



2. Open the “Vive Precision” app on your smart device and sign up for a new account or login to your existing account.
3. Turn on the Sync feature of the smart device.
4. Make sure the Sync feature of the monitor is on. To turn on/off the sync feature of the monitor: Press and hold the button to enter the setting mode. Press to turn the sync feature ON and OFF.
5. Go to Device Setup in the menu.
6. Choose your device and follow the on-screen instructions to connect your device.
7. Click the *sync* button on the monitor to transfer data from the device to the app.

TRANSFER MEASUREMENT DATA TO SMART DEVICE

1. Make sure the monitor is within 5m of your smart device and the “Vive Precision” app is active.
2. Make sure the Auto-Sync feature of the monitor is on and press the sync button to activate the Sync communication.

3. Press the sync button again to transfer data.

Notes:

- If data transmission fails, error code "E7" will be shown. Check the Sync feature of the monitor and your smart device.
- The monitor comes with the Sync already turned on as default. Please turn off the Sync feature in the monitor in the areas where use of wireless equipment is prohibited.

PRESSURE BAR INDICATOR

During the blood pressure and pulse rate measurement, the Pressure Bar Indicator illustrates the cuff pressure condition.

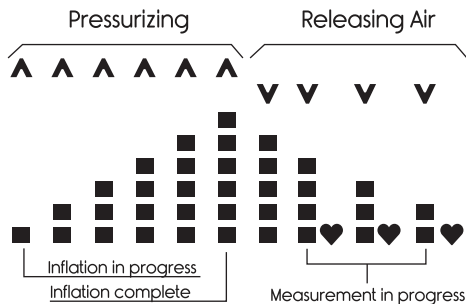

WHO CLASSIFICATION INDICATOR

The World Health Organization (WHO) has established the following chart as a standard to assess high blood pressure, regardless of age.

Reference Material: Journal of Hypertension 1999, Vol 17 No.2

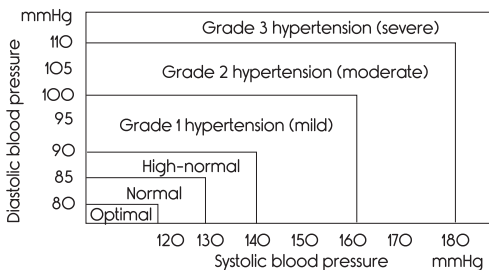

The WHO Classification Indicator is a feature which provides a snapshot of your blood pressure classification based on your measurements. This will help you to understand what your blood pressure values mean. Each segment of the bar indicator corresponds to the WHO blood pressure classification.

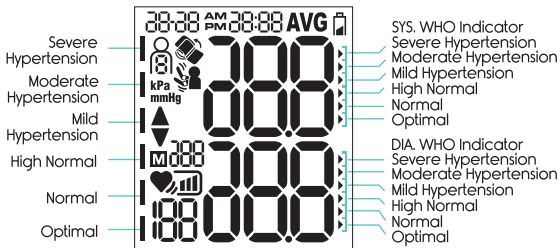

ABOUT IRREGULAR HEARTBEAT [IHB]

An irregular heartbeat is defined as a heartbeat that varies by 25% from the average of all heartbeats during the blood pressure measurement. When the device detects an irregular heartbeat two or more times during the measurement, the Irregular Heartbeat indicator will appear on the display.

It is important that you are sitting relaxed, still, and quiet during measurement.

ABOUT IHB % INDICATION

IHB % Indicator is only enabled when showing average results of the data (All AVG, AM AVG and PM AVG).

Calculation of IHB %	
ALL	AVG IHB % = $\frac{\text{Number of detected IHBs in memory}}{\text{Total number of measurements}} \times 100\%$
ALL	AVG IHB % = $\frac{\text{Number of detected IHBs in latest 7 days morning}}{\text{Total number of measurements in latest 7 days morning}} \times 100\%$
PM	AVG IHB % = $\frac{\text{Number of detected IHBs in latest 7 days night}}{\text{Total number of measurements in latest 7 days night}} \times 100\%$

Frequency of IHB



Normal



Irregular Heartbeat Indicator (frequency of IHB 0-24%)



Irregular Heartbeat Indicator (frequency of IHB 25-49%)



Irregular Heartbeat Indicator (frequency of IHB 50-74%)



Irregular Heartbeat Indicator (frequency of IHB 75-100%)

⚠ CAUTION: If the irregular heartbeat indicator  displays frequently after the measurement, you are recommended to consult your physician.

ABOUT BLOOD PRESSURE

WHAT IS BLOOD PRESSURE?

Blood pressure is the force exerted by blood against the walls of the arteries. Systolic pressure occurs when the heart expands. Blood pressure is measured in millimeters of mercury (mmHg). One's natural blood pressure is represented by the fundamental pressure, which is measured first thing in the morning while one is still at rest and before eating.

WHAT IS HYPERTENSION AND HOW IS IT CONTROLLED?

Hypertension, an abnormally high arterial blood pressure, if left unattended, can cause many health problems including stroke and heart attack. Hypertension can be controlled by

by altering one's lifestyle, avoiding stress, and with medication under a doctor's supervision. To prevent hypertension or to keep it under control:

- Do not smoke
- Exercise regularly
- Reduce salt and fat intake
- Have regular physical checkups
- Maintain proper weight



WARNINGS AND PRECAUTIONS

- DO NOT use this device on newborns, infants, children, toddlers, or persons who cannot express their intentions. The device is designed for use on adults only.
- DO NOT self-diagnose from the measurement results and attempt treatment by yourself.
- DO NOT adjust medication based on the measurement results.
- Consult your physician for specific information about your blood pressure.
- The Irregular Heartbeat detection function may help to detect potential cardiac arrhythmia at an early stage but it is not intended to replace cardiac examination.
- The "WHO Blood Pressure Classification" chart is a guide for reference and is not intended to replace medical diagnosis.
- Use the device only as intended. Do not use the device for any other purpose.

- Do not apply the device on an arm with an unhealed wound or under medical treatment.
- Do not take measurements more than necessary. High measurement repetition rates may cause pain, numbness, temporary red marks or bruising to the arm due to blood flow interference.
- If you have any of the following medical conditions, you may get an inaccurate reading with the device. Please consult your physician before using the device.
 - Patients in shock
 - Cardiac arrhythmias
 - Atrial or ventricular premature beats
 - Atrial fibrillation
 - Arteriosclerosis
 - Poor perfusion
 - Vessel anomalies
 - Very low blood pressure
 - Pregnancy
 - Diabetes
 - Pre-eclampsia
 - Renal diseases
 - Underwent breast or axillary lymph node removal operation
 - With an arteriovenous shunt.
 - With an intravenous drip or blood transfusion.
 - With an implanted electrical device such as a cardiac pacemaker.
 - With other medical electrical equipment attached.
 - With condition that may compromise circulation.
 - Severe blood flow problems or blood disorders, as cuff inflation can cause bruising.
 - Trembling or shivering
- Do not use the device with other medical electrical equipment simultaneously.
- Do not use the device where high frequency surgical equipment, magnetic resonance imaging (MRI), computerized tomography (CT) scanner or X-ray machine is operating.

- Do not use the device near electromagnetic fields emission equipment such as cellular phones, microwave ovens, or televisions.
- Do not use the device where flammable gases (e.g. anesthetics gas, oxygen, and hydrogen) or flammable liquids (e.g. alcohol) are present.
- Do not use the device in a moving vehicle such as a car or an airplane.
- Do not use the device outside the specified environment. It may cause an inaccurate reading.
- The product contains small parts that may cause a choking hazard to infants and children. Keep the device and its parts out of reach of infants and children.
- Do not attempt to open, disassemble, repair, modify or adjust the device by yourself. It may cause an accident, damage the device, cause inaccurate measurement and void the user warranty.
- Do not subject the device to strong knocks (e.g. dropping the unit on the floor), extreme temperatures, high humidity, direct sunlight, dust or chemicals. This may damage the device.
- The device is not water resistant. Avoid water, rain, or sweat from infiltrating the device.
- Clean the device and cuff carefully with a dry, soft cloth, or a cloth dampened with water. Do not use aggressive solvents such as alcohol, benzene, thinner or other strong chemicals to clean the device.

- Do not fold the cuff tightly for a long period. Such conditions may shorten the life of the part.
- Dispose used equipment, parts, batteries, and optional accessories according to applicable local regulations. Unlawful disposal may cause environmental pollution.
- Do not wrap the cuff around body parts other than your upper left arm. Misuse represents a risk to your health.
- Packaging materials are a deadly hazard for children and can cause suffocation. Remove all packaging materials immediately and keep them away from children at all times.
- Proper cuff size is important for accurate measurements. Only use the device on adults who have the right upper arm circumference for this unit. See "TECHNICAL SPECIFICATION" for suitable arm circumferences.
- Batteries should not be charged or reactivated by any other means. The batteries may explode.
- Take extra precautions to keep a leaking battery away from fire as there is a risk of ignition or explosion.
- Do not use any cuffs or accessories other than those explicitly recommended by the manufacturer for use with this product. Cuffs and accessories not approved for use with this device may cause damage to your health and to the product.
- The tubing presents a strangulation hazard. Keep this product away from children and those who require close supervision, e.g. people with mental disorders.

- In case the cuff does not stop inflating, interrupt the measurement by pressing the ON/OFF button and open the cuff at once.
- Do not drape the tube around your own or anyone else's neck. This presents a strangulation hazard.
- Remove any kind of arm jewellery or the like before taking a measurement. This could cause bruises.
- Do not place the arm cuff over heavy clothing (e.g. a jacket or sweater sleeve) as the blood pressure monitor will not be able to take a proper measurement and there is an elevated danger of acquiring hematoma or skin marks during the course of the measurement.
- When applying the cuff, make sure there are no wrinkles in the cuff as this could cause bruises.
- Blood pressure measurements can lead to temporary marks on the skin at the site of the cuff placement. This is especially the case in high repetition rates. In rare cases, a mark may persist for a couple of days. Please contact your physician about these specific risks of cuff pressure in your specific case.
- Do not exert any kind of pressure on the hose during measurement, e.g. laying your arms or any other object on the hose. This could cause incorrect measurements.
- The device is designed and manufactured for a long service life. However, it is generally recommended to have the monitor inspected every 2 years to ensure proper functioning and accuracy. Please contact your dealer for maintenance.

- Do not drop or insert any object into any openings or hoses. This may damage the unit.
- Do not press the buttons with excessive force or with pointed objects.
- When storing the device, make sure that no heavy objects are placed on top of it.



TROUBLESHOOTING

Problem	Probable Cause	Correction
Nothing appears on the display, even when the power is turned on.	Batteries are drained.	Replace all used batteries with new batteries.
	Batteries are not installed in correct polarities.	Batteries are not installed in correct polarities.
ERROR code 1 (E1) appears	No pulse signal is detected. The cuff may not be applied correctly.	Reapply the cuff and fasten the cuff correctly.
ERROR code 2 (E2) appears	Noise is detected. Your arm or body is moving during the measurement.	Remain still and do not talk during the measurement.

<p>ERROR code 3 (E3) appears</p>	<p>No pressure is detected. The cuff may not be fastened properly or is too loose.</p>	<p>Reapply the cuff and fasten the cuff correctly.</p>
<p>ERROR code 4 (E4) appears</p>	<p>The device cannot measure the blood pressure correctly.</p>	<p>If the heartbeat is very weak or irregular, the device may not be able to measure the blood pressure. Reapply the cuff and fasten the cuff correctly. Sit comfortably and remain still during the measurement.</p>
<p>ERROR code 5 (E5) appears</p>	<p>The cuff is over inflated. Blood pressure over 300 mmHg.</p>	<p>It is recommended to consult your physician immediately.</p>
<p>ERROR code 6 (E6) appears</p>	<p>Low battery level.</p>	<p>Replace all used batteries with new batteries.</p>
<p>ERROR code 7 (E7) appears</p>	<p>Data transmission failure.</p>	<p>Check the connection of the device and the smart device.</p>
<p>The monitor keeps re-inflating</p>	<p>System lockup.</p>	<p>Restart the device. Remove the batteries, wait for 1 minute, and then re-install the batteries.</p>

TECHNICAL SPECIFICATION

Model No.	DMD1O47
Display	LCD Display
Measurement Method	Non-invasive, Oscillometric method
Measurement Range	Systolic Blood Pressure: 50–250 mmHg Diastolic Blood Pressure: 30–200 mmHg Pulse Rate: 40–180 beats/minute
Accuracy	Pressure: +/- 3 mmHg Pulse Rate: +/- 5% of reading
Resolution	Pressure: 1 mmHg Pulse Rate: 1 beat/minute
Memory	960 (240 x 4 users)
Dimensions	Approx. 4.6" x 6.1" x 3" (117 x 154 x 75mm)
Cuff Size / Arm Circumference Range	Standard: 9" - 14" (22cm-36cm) Large: 14" - 17" (35cm-44cm) Full Range: 9" - 17" (22cm-44cm)
Operating Temperature	41°F to 104°F (5°C to 40°C)
Operating Humidity	15 to 90% RH
Storage Temperature	-13°F to 158°F (-25°C to 70°C)
Storage Humidity	Up to 93% RH
Operation, storage and transport atmospheric pressure	700hPa to 1060hPa

Power Source	4 x 1.5V AA alkaline batteries (Optional AC Adapter: 6VDC@600mA)
Accessories	Cuff (Standard), Instruction Manual, Storage Pouch, Batteries
Classification	Application part Type BF
Key to symbols	Application part Type BF  Class II equipment symbol 

APPENDIX I

Guidance and manufacturer's declaration - electromagnetic emissions		
The Sphygmomanometer (DMD1O47) is intended for use in the electromagnetic environment specified below. The customer or user of the device should assure that it is used in such an environment.		
Conducted and radiated RF EMISSIONS	Compliance	Electromagnetic Environment Guidance
RF emissions CISPR11	Group 1	The device uses RF energy only for its internal function. Therefore, its RF emissions are very low and are not likely to cause any interference in nearby electronic equipment.

RF emissions CISPR11	Class B	The device is suitable in all establishments, other than domestic and those directly connected to the public low-voltage power supply network that supplies buildings used for domestic purposes.
----------------------	---------	---

APPENDIX II

Guidance and manufacturer's declaration - electromagnetic immunity			
The device is intended for use in the electromagnetic environment specified below. The customer or the user of the device should assure that it is used in such an environment.			
Immunity Test	IEC 60601 test level	Compliance level	Electromagnetic environment guidance
Electrostatic Discharge IEC 61000-4-2	M8 kV contact N. 15 kV air	M8 kV contact N. 15 kV air	Floors should be wood, concrete or ceramic tile. If floors are covered with synthetic material, the relative humidity should be at least 30%.

<p>Power frequency (50Hz / 60Hz) Magnetic field IEC 61000-4-8</p>	<p>30 A/m 50Hz/60Hz</p>	<p>30 A/m 50Hz/60Hz</p>	<p>Power frequency magnetic fields should be at levels characteristic of a typical location in a typical commercial or hospital environment.</p>
<p>Conducted RF IEC 61000-4-6</p>	<p>3 Vrms 0.15 MHz - 80 MHz 6 Vrms in ISM and amateur radio bands between 0.15 MHz and 80 MHz 80% AM at 1 kHz</p>	<p>3 Vrms 0.15 MHz - 80 MHz 6 Vrms in ISM and amateur radio bands between 0.15 MHz and 80 MHz 80% AM at 1 kHz</p>	<p>Portable and mobile RF communications equipment should be used no closer to any part of the Sphygmomanometer (DMD1047), including cables, than the recommended separation distance calculated from the equation applicable to the frequency of the transmitter. Recommended separation distance</p>
			<p>Recommended separation distance</p> $d = \left[\frac{6}{E} \right] \sqrt{P}$ <p>where P is the maximum output power rating of the transmitter in Watts (W), d is the minimum recommended separation distance in meters (m), and</p>

			<p>E is the immunity test level in V/m. Field strengths from fixed RF transmitters, as determined by an electromagnetic site survey, should be less than the compliance level in each frequency range. Interference may occur in the vicinity of equipment marked with the following symbol:</p> 
--	--	--	--

NOTE: These guidelines may not apply in all situations. Electromagnetic propagation is affected by absorption and reflection from structures, objects and people.

APPENDIX III

Recommended separation distances between portable and mobile RF communications equipment and the device.

The device is intended for use in an electromagnetic environment in which radiated RF disturbances are controlled. The customer or the user of the device can help prevent electromagnetic interference by maintaining a minimum distance between portable and mobile RF communications equipment (transmitters) and the device as recommended below, according to the maximum output power of the communications equipment.

Rated maximum output power of transmitter (W)	Separation distance according to frequency of transmitter (m)	
	3 Vrms	10 V/m
0.01	0.200	0.060
0.1	0.632	0.190
1	2.000	0.600
10	6.33	1.90
100	20.0	6.00

For transmitters rated at a maximum output power not listed above, the recommended separation distance d in meters (m) can be estimated using the equation applicable to the frequency of the transmitter, where P is the maximum output power rating of the transmitter in watts (W) according to the transmitter manufacturer.

NOTE: These guidelines may not apply in all situations. Electromagnetic propagation is affected by absorption and reflection from structures, objects and people.

APPENDIX IV

This equipment has been tested and found to comply with the limits for a Class B digital device, pursuant to part 15 of the FCC Rules. These limits are designed to provide reasonable protection against harmful interference in a residential installation. This equipment generates, uses, and can radiate radio frequency energy and, if not installed and used in accordance with the instructions, may cause harmful interference to radio communications. However, there is no guarantee that interference will not occur in a particular installation. If this equipment does cause harmful interference to radio or television reception, which can be determined by turning the equipment off and on, the user is encouraged to try to correct the interference by one or more of the following measures:

- Reorient or relocate the receiving antenna.
- Increase the separation between the equipment and receiver.
- Connect the equipment into an outlet on a circuit different from that to which the receiver is connected.
- Consult the dealer or an experienced technician for help.

WARNINGS

- To comply with the limits of the Class B digital device, pursuant to Part 15 of the FCC Rules, this device is comply with Class B limits. All peripherals must be shielded and grounded. Operation with non-certified peripherals or non-shielded cables may result in interference to radio or reception.
- Any changes or modifications not expressly approved by the grantee of this device could void the user's authority to perate the device.

GOT MORE QUESTIONS?

Check out our list of Frequently Asked Questions at vhealth.link/olu for helpful answers.



And if that doesn't answer your question, our customer service team would love to help! Feel free to connect with them by phone, e-mail, or chat on our website.

 service@vivehealth.com

 1-800-487-3808

 vivehealth.com

Distributed by

vive health

8955 Fontana Del Sol Way

Naples, FL 34109

1-800-487-3808

www.vivehealth.com