



THE COMPLETE HEAVY LOAD MOVING SOLUTIONS PROVIDER



OVER 65 YEARS OF EXCELLENCE

ENGINEERED
SOLUTIONS

WWW.HILMANROLLERS.COM

MADE IN USA 

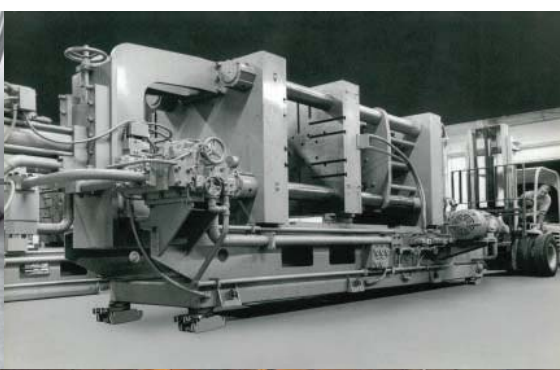

HILMAN

Hilman Inc. designs, engineers and manufactures high capacity rollers, powered heavy moving systems, and custom load moving solutions.

With more than 65 years of innovation and experience, Hilman has earned and maintained a reputation for offering its customers the highest standards of quality, consistency and value making us a world leader when it comes to heavy load moving solutions.

Our high capacity rollers are known throughout the world for their dependability, flexible design, and durability and have been the benchmark by which all other machinery rollers and load moving systems are

measured. In addition, we can design and fabricate custom load moving systems for heavy moving problems that require special attention.

We manufacture our products in the USA. Hilman Inc. is ISO-9001:2015 approved and can submit for the approval of Lloyd's, DNV and ABS as well as other third parties.

Hilman is always up for a challenge. If you have a specific project and would like to learn more about our custom load moving solutions, please contact us.



KITS & SETS



EASY TO CHOOSE, EASY TO USE

Hilman Rollers are high capacity, low profile roller dollies that utilize a recirculating chain design for moving, shifting or positioning heavy weights.

FT SERIES



Variety of Top Styles – versatile top configurations are built into the body of the roller. These steel chain action rollers are a great choice to move heavy equipment over ordinary concrete floors.

NYTON SERIES



Floor Protection – High impact synthetic Nylon rolls are used instead of steel for protection on delicate floor surfaces such as new concrete, epoxy coated surfaces, painted or sealed floors.

ERS SERIES



Lowest Height – Two-piece design features an open top base roller with serrated side plates to maintain a firm grip on moving loads plus detachable swivel attachments.

LIFT



SET



ROLL



ROLLER CONFIGURATIONS

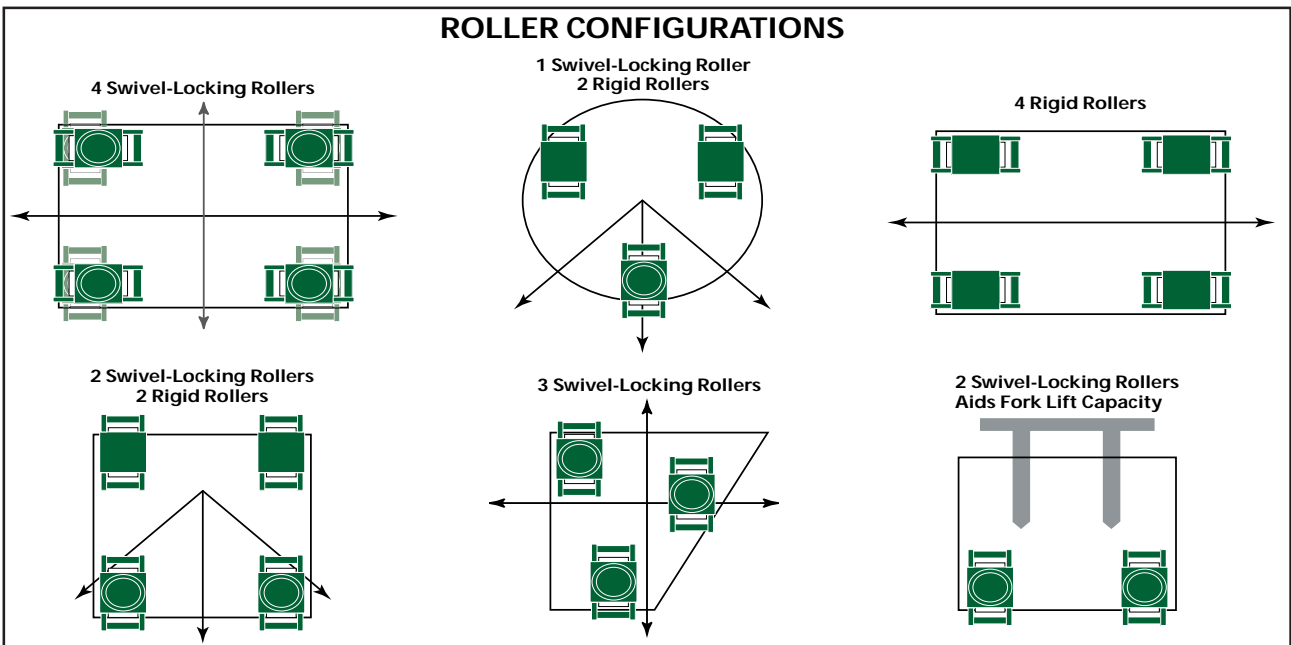

FT ADVANTAGES

Choose swivel for turning or rigid for straight line moving in a track or standalone.

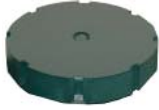

SMOOTH STEEL TOPS (S)
ideal for weld mounting the rollers to equipment or as a base unit for a variety of top modifications.



PADDED STEEL TOPS (P)
allow some compression and provide a non-slip surface for moving on less than perfect floors.



DIAMOND STEEL TOP (D)
spike-like steel grid able to grip into wood and provide a secure move for crated or palletized equipment.

VERSATILE TOP PLATES

LOCKING (OPTIONAL)
for added control on long straight moves. Unlock swivel for turning.

CAST STEEL FRAME
for high quality



LOW MAINTENANCE
chains require no bearings or additional lubrication

WIDE CHAIN TRACK
distributes load over a greater area

LOW FRICTION
Endless roller chain operates without axle or journal friction as they rotate about the load bearing frame plate. Each roll turns individually giving a friction-free creeping motion.

HARDENED, PRECISION GROUND CHAIN ROLLS
for durability and extra long life



HANDLE
for good grip and positioning

HIGH IMPACT NYLON CHAIN (NYTON)
for delicate floors



INDIVIDUAL

The FT Series offers the widest array of top configurations that are built right into the body of the roller. With six individual roller capacities, these steel chain action rollers are a perfect choice to move heavy equipment over ordinary concrete floors.



SP



SS



RP



RS



SLP



SLD



SLS



RD

Hilman Part #	Top Style	Capacity (tons)	Length (in) (mm)		Width (in) (mm)		Height (in) (mm)		Weight (lbs) (kg)		Contact Rolls
.75-SP	SWIVEL	0.75	6 1/2	165	3 5/8	92	3 5/16	84	9	4	5
2-SP	PADDED	2	6 1/2	165	4 1/8	92	3 15/16	79	15	4	5
.75-SS	SWIVEL	0.75	6 1/2	165	3 5/8	92	3 5/16	84	9	4	5
2-SS	SMOOTH	2	6 1/2	165	4 1/8	92	3 11/16	70	15	4	5
.75-RP		0.75	6 1/2	165	3 5/8	105	3 1/8	100	9	7	4
2-RP		2	6 1/2	165	4 1/8	105	3 5/8	92	15	7	4
3.75-RP		3.75*	10 1/2	267	5 3/4	146	4 3/16	106	29	13	5
7.5-RP	RIGID	7.5*	10 1/2	267	5 3/4	146	4 7/16	113	33	15	4
10-RP	PADDED	10*	10 1/2	267	5 3/4	146	4 7/16	113	33	15	4
15-RP		15	12 3/4	324	6 3/8	162	4 5/16	110	42	19	5
30-RP		30*	15	380	8	203	6 3/4	171	107	49	5
50-RP		50*	21	533	8	203	7 3/4	197	179	81	7
.75-RS		0.75	6 1/2	165	3 5/8	105	2 3/4	94	9	7	4
2-RS		2	6 1/2	165	4 1/8	105	3 1/4	83	15	7	4
3.75-RS	RIGID	3.75*	10 1/2	267	5 5/8	143	3 11/16	94	29	13	5
7.5-RS	SMOOTH	7.5*	10 1/2	267	5 5/8	143	3 15/16	100	32	15	4
10-RS		10*	10 1/2	267	5 5/8	143	3 15/16	100	32	15	4
15-RS		15	12 3/4	324	6 3/8	162	3 13/16	97	43	20	5
30-RS		30*	15	380	8	203	5 3/4	146	105	48	5
50-RS		50*	21	533	8	203	6 3/4	171	176	80	7
3.75-SLP		3.75*	10 1/2	267	5 3/4	146	5	127	34	15	5
7.5-SLP	SWIVEL	7.5*	10 1/2	267	5 3/4	146	5 1/4	133	38	17	4
10-SLP	LOCKING	10*	10 1/2	267	5 3/4	146	5 1/4	133	38	17	4
15-SLP	PADDED	15	12 3/4	324	6 3/8	162	5 1/8	130	49	22	5
30-SLP		30*	15	380	8	203	8	203	122	55	5
50-SLP		50*	21	533	8	203	8 5/16	227	193	88	7
3.75-SLD		3.75*	10 1/2	267	5 3/4	146	4 3/4	121	34	15	5
7.5-SLD	SWIVEL	7.5*	10 1/2	267	5 3/4	146	5	127	37	17	4
10-SLD	LOCKING	10*	10 1/2	267	5 3/4	146	5	127	37	17	4
15-SLD	DIAMOND	15	12 3/4	324	6 3/8	162	4 7/8	124	49	22	5
30-SLD		30	15	380	8	203	7 3/32	180	118	54	5
50-SLD		50	21	533	8	203	8 1/16	205	189	86	7
3.75-SLS		3.75*	10 1/2	267	6	152	4 5/8	117	35	16	5
7.5-SLS	SWIVEL	7.5*	10 1/2	267	6	152	4 7/8	124	38	17	4
10-SLS	LOCKING	10*	10 1/2	267	6	152	4 7/8	124	38	17	4
15-SLS	SMOOTH	15	12 3/4	324	6 3/8	162	4 3/4	121	50	23	5
30-SLS		30	15	380	8	203	6 31/32	177	119	54	5
50-SLS		50	20 7/8	530	8	203	7 15/16	202	191	87	7
3.75-RD		3.75*	10 1/2	267	5 3/4	146	4 1/16**	103	29	13	5
7.5-RD		7.5*	10 1/2	267	5 3/4	146	4 5/16**	110	32	15	4
10-RD	RIGID	10*	10 1/2	267	5 3/4	146	4 5/16**	110	32	15	4
15-RD	DIAMOND	15	12 3/4	324	6 3/8	162	4 3/32**	104	38	17	5
30-RD		30*	15	380	8	203	6 1/8**	156	105	48	5
50-RD		50*	21	533	8	203	7 1/8**	181	176	80	7

*Width dimension of top exceeds roller frame width

** Height to top of spike

KITS & SETS

Hilman Part #	Kit/Set Capacity	Kit / Set Include	Weight	
			(lbs)	(kg)
KRS-3-2S/2R	3	(2) 0.75-SP Rollers, (2) 0.75-RP Rollers, (2) 3-KH Handles , Case	55	25
RS-3-2S/2R	3	(2) 0.75-SP Rollers, (2) 0.75-RP Rollers, (2) 3-KH Handles	52	24
KRS-3-4S	3	(4) 0.75-SP Rollers, (2) 3-KH Handles, Case	55	25
RS-3-4S	3	(4) 0.75-SP Rollers, (2) 3-KH Handles	52	24
KRS-8-2S/2R	8	(2) 2-SP Rollers, (2) 2-RP Rollers, (2) 8-KH Handles, Case	85	39
RS-8-2S/2R	8	(2) 2-SP Rollers, (2) 2-RP Rollers, (2) 8-KH Handles	76	35
KRS-8-4S	8	(4) 2-SP Rollers, (2) 8-KH Handles, Case	85	39
RS-8-4S	8	(4) 2-SP Rollers, (2) 8-KH Handles	76	35
KRS-15-SLP	15	(4) 3.75-SLP Rollers; (2) KDH48F Handles; Case	203	92
RS-15-SLP	15	(4) 3.75-SLP Rollers; (2) H36F 36" Handles	156	71
KRS-15-SLD	15	(4) 3.75-SLD Rollers; (4) P-1 Preload Pads; (2) KDH48F Handles; Case	203	92
RS-15-SLD	15	(4) 3.75-SLD Rollers; (4) P-1 Preload Pads; (2) H36F 36" Handles	156	71
KRS-30-SLP	30	(4) 7.5-SLP Rollers; (2) KDH48F Handles; Case	215	98
RS-30-SLP	30	(4) 7.5-SLP Rollers; (2) H48F 48" Handles	172	78
KRS-30-SLD	30	(4) 7.5-SLD Rollers; (4) P-1 Preload Pads; (2) KDH48F Handles; Case	215	98
RS-30-SLD	30	(4) 7.5-SLD Rollers; (4) P-1 Preload Pads; (2) H48F 48" Handles	172	78
KRS-40-SLP	40	(4) 10-SLP Rollers; (2) KDH48F Kit Size Handles; Case	219	99
RS-40-SLP	40	(4) 10-SLP Rollers; (2) H48F 48" Handles	176	80
KRS-40-SLD	40	(4) 10-SLD Rollers; (4) P-1 Preload Pads; (2) KDH48F Handles; Case	219	99
RS-40-SLD	40	(4) 10-SLD Rollers; (4) P-1 Preload Pads; (2) H48F 48" Handles	176	80
KRS-60-SLP	60	(4) 15-SLP Rollers; (2) KDH48F Kit Size Handles; Case	255	116
RS-60-SLP	60	(4) 15-SLP Rollers; (2) H48F 48" Handles	212	96
KRS-60-SLD	60	(4) 15-SLD Rollers; (4) P-1 Preload Pads; (2) KDH48F Handles; Case	259	117
RS-60-SLD	60	(4) 15-SLD Rollers; (4) P-1 Preload Pads; (2) H48F 48" Handles	216	98
RS-120-SLP	120	(4) 30-SLP Rollers; (2) H60F 60" Handles	542	256
RS-120-SLD	120	(4) 30-SLD Rollers; (4) P-2 Preload Pads; (2) H60F 60" Handles	540	245
RS-200-SLP	200	(4) 50-SLP Rollers; (2) H60F 60" Handles	834	378
RS-200-SLD	200	(4) 50-SLD Rollers; (4) P-2 Preload Pads; (2) H60F 60" Handles	848	385



*All Kits 15 to 60 tons include- Steel Case Kit Box KB-D2: 27.75" (705mm) x 14.75" (375mm) x 9.63" (245mm)

*All Kits 3 to 8 tons include- Steel Case Kit Box KB-D1: 16" (406mm) x 12.375" (314mm) x 4.44" (113mm)

Hilman Part #	Fits	Fits	Description	Length		Weight	
				(in)	(mm)	(lbs)	(kg)
3-KH	FT 3 ton Kits	Nyton 2 ton Kits	One Part Kit Size Handle	15	381	3	1
8-KH	FT 8 ton Kits	Nyton 4 ton Kits	Two Part Kit Size Handle	30	762	6	3
KDH48F	FT 15 - 60 ton Kits	Nyton 8 - 24 ton Kits	Two Part Kit Size Handle	48	1219	12	5
H36F	FT 3.75 - 15 ton Rollers	Nyton 2 - 6 ton Rollers	One Part Handle	36	914	10	5



NYTON

The Nyton series is designed for heavy moving capabilities on delicate floor surfaces such as new concrete, epoxy coated surfaces, painted or sealed floors, and some properly supported tile and terrazzo floors.

Hilman Part #	Capacity (tons)	Length		Width		Height		Weight		Contact Rolls	Type	Top Style
		(in)	(mm)	(in)	(mm)	(in)	(mm)	(lbs)	(kg)			
N.5-SP	0.5	6 1/2	165	3 5/8	92	3 7/16	87	7	3	5	Swivel	Padded
N1-SP	1	6 1/2	165	4 1/8	105	3 15/16	100	12	5	4	Swivel	Padded
N2-SLP*	2	10 1/2	267	5 3/4	146	5	127	28	13	5	Swivel	Padded
N3-SLP*	3	10 1/2	267	5 3/4	146	5 1/4	134	29	13	4	Swivel	Padded
N6-SLP	6	12 3/4	324	6 3/8	162	5 1/8	130	36	16	5	Swivel	Padded
N10-SLP	10	15	381	8	203	7 31/32	202	100	45	5	Swivel	Padded
N.5-RP	0.5	6 1/2	165	3 5/8	92	3 1/8	80	6	3	5	Rigid	Padded
N1-RP	1	6 1/2	165	4 1/8	105	3 5/8	92	11	5	4	Rigid	Padded
N2-RP*	2	10 1/2	267	5 3/4	146	4 3/16	107	23	10	5	Rigid	Padded
N3-RP*	3	10 1/2	267	5 3/4	146	4 7/16	113	24	11	4	Rigid	Padded
N6-RP	6	12 3/4	324	6 3/8	162	4 5/16	110	31	14	5	Rigid	Padded
N10-RP	10	15	381	8	203	6 3/4	171	86	39	5	Rigid	Padded

*Width dimension of top exceeds roller frame width



Hilman Part #	Kit/Set Capacity (tons)	Kit/Set Include	Weight	
			(lbs)	(kg)
KNRS-2-2S/2R	2	(2) N.5-SP Rollers, (2) N.5-RP Rollers, (2) 3-KH Handles; Case	45	20
NRS-2-2S/2R	2	(2) N.5-SP Rollers, (2) N.5-RP Rollers, (2) 3-KH Handles	42	19
KNRS-2-4S	2	(4) N.5-SP Rollers, (2) 3-KH Handles; Case	47	21
NRS-2-4S	2	(4) N.5-SP Rollers, (2) 3-KH Handles	44	20
KNRS-4-2S/2R	4	(2) N1-SP Rollers, (2) N1-RP Rollers, (2) 8-KH Handles; Case	69	31
NRS-4-2S/2R	4	(2) N1-SP Rollers, (2) N1-RP Rollers, (2) 8-KH Handles	60	27
KNRS-4-4S	4	(4) N1-SP Rollers, (2) 8-KH Handles; Case	69	31
NRS-4-4S	4	(4) N1-SP Rollers, (2) 8-KH Handles	60	27
KNRS-8-SLP	8	(4) N2-SLP Rollers, (2) KD48F Kit Size Handles; Case	179	81
NRS-8-SLP	8	(4) N2-SLP Rollers, (2) KD48F Kit Size Handles	136	62
KNRS-12-SLP	12	(4) N3-SLP Rollers, (2) KD48F Kit Size Handles; Case	179	81
NRS-12-SLP	12	(4) N3-SLP Rollers, (2) KD48F Kit Size Handles	136	62
KNRS-24-SLP	24	(4) N6-SLP Rollers, (2) KD48F Kit Size Handles; Case	203	92
NRS-24-SLP	24	(4) N6-SLP Rollers, (2) KD48F Kit Size Handles	160	73
NRS-40-S;P	40	(4) N10-SLP Rollers, (2) H60F 60" Handles	458	208

*All Kits include- Steel Case Kit Box KB-D2: 27.75" (705mm) x 14.75" (375mm) x 9.63" (245mm)



ERS ADVANTAGES

The ERS Series features a two-piece design with a base roller with serrated side plates to maintain a firm grip on moving loads plus detachable swivel attachments. Manually situated on the Rollers, these optional attachments enhance maneuverability and add minimal height to the basic roller. It is especially valuable for tasks requiring a roller with low clearance.

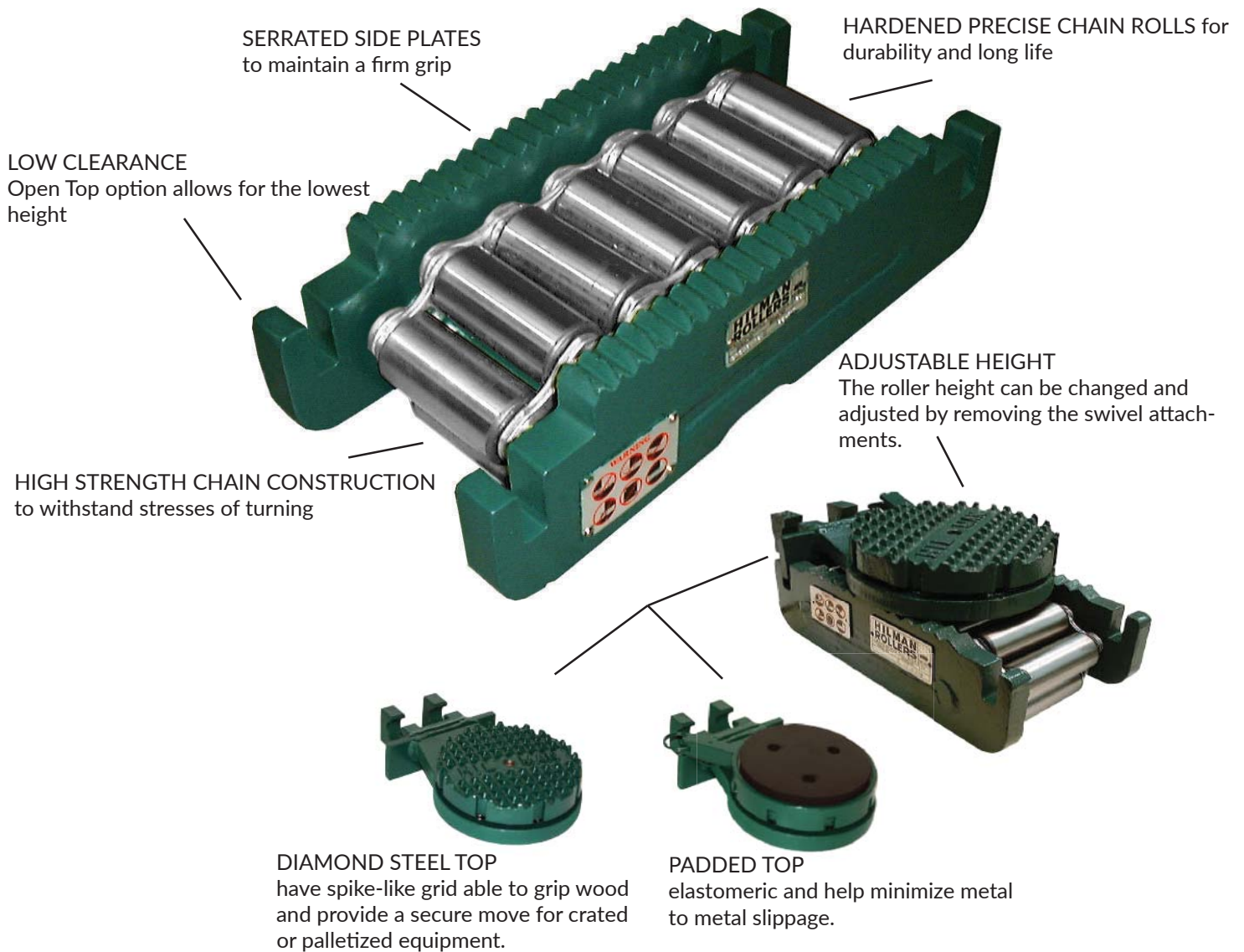

Hilman Part #	Capacity (tons)	Length		Width		Height		Weight		Contact Rolls
		(in)	(mm)	(in)	(mm)	(in)	(mm)	(lbs)	(kg)	
3.75-ERS	3.75	8 5/8	219	4 7/16	113	2 3/4	70	15	7	5
5-ERS	5	8 5/8	219	5 5/16	135	2 3/4	70	20	9	5
10-ERS	10	10 3/8	264	5 3/16	132	3 3/8	86	29	13	5
12.5-ERS	12.5	10 3/8	264	5 5/8	143	3 3/8	86	31	14	5
25-ERS	25	5 3/4	400	7 1/4	184	4 3/4	121	79	36	5
65-ERS	65	23	584	7 3/8	187	5 5/8	143	156	71	7
100-ERS	100	23	584	7 7/8	200	5 5/8	143	165	75	7

KITS & SETS



Hilman Part #	Kit/Set Capacity (tons)	Kit/Set Include	Weight	
			(lbs)	(kg)
KRS-15-ERSD	15	(4) 3.75-ERS Rollers, (4) T-3.75-LD Swivel Locking Diamond Attachments, (4) P-1 Preload Pads, (2) KDH48E Kit Size Handles; Case	181	82
RS-15-ERSD	15	(4) 3.75-ERS Rollers, (4) T-3.75-LD Swivel Locking Diamond Attachments, (4) P-1 Preload Pads, (2) H36E 36" Handles	130	59
KRS-20-ERSD	20	(4) 5-ERS Rollers, (4) T-5-LD Swivel Locking Diamond Attachments, (4) P-1 Preload Pads, (2) KDH48E Kit Size Handle; Case	201	91
RS-20-ERSD	20	(4) 5-ERS Rollers, (4) T-5-LD Swivel Locking Diamond Attachments, (4) P-1 Preload Pads, (2) H36E 36" Handles	150	68
KRS-40-ERSD	40	(4) 10-ERS Rollers, (4) T-10-LD Swivel Locking Diamond Attachments, (4) P-1 Preload Pads, (2) KDH48E Kit Size Handles; Case	241	109
RS-40-ERSD	40	(4) 10-ERS Rollers, (4) T-10-LD Swivel Locking Diamond Attachments, (4) P-1 Preload Pads, (2) H48E 48" Handles	196	89
KRS-50-ERSD	50	(4) 12.5-ERS Rollers, (4) T-12.5-LD Swivel Locking Diamond Attachments, (4) P-1 Preload Pads, (2) KDH48E Kit Size Handles; Case	249	113
RS-50-ERSD	50	(4) 12.5-ERS Rollers, (4) T-12.5-LD Swivel Locking Diamond Attachments, (4) P-1 Preload Pads, (2) H48E 48" Handles	204	93
RS-100-ERSD	100	(4) 25-ERS Rollers, (4) T-25-LD Swivel Locking Diamond Attachments, (4) P-2 Preload Pads, (2) H48E 48" Handles	514	233
RS-260-ERSD	260	(4) 65-ERS Rollers, (4) T-65-LD Swivel Locking Diamond Attachments, (4) P-2 Preload Pads, (2) H60E 60" Handles	870	395
RS-400-ERSD	400	(4) 100-ERS Rollers, (4) T-100-LD Swivel Locking Diamond Attachments, (4) P-2 Preload Pads, (2) H60E 60" Handles	906	411

Swivel Locking Diamond Top	Swivel Locking Padded Top	Fits Individual Roller Part #	Padded (P) Style Height*		Diamond (D) Style Height*		Attachment Width		Length*		Weight	
			(in)	(mm)	(in)	(mm)	(in)	(mm)	(in)	(mm)	(lbs)	(kg)
T-3.75-LD	T-3.75-LP	3.75-ERS	4 11/16	119	4 7/16	113	5 7/8	149	10 3/4	273	13	6
T-5-LD	T-5-LP	5-ERS	4 11/16	119	4 7/16	113	5 7/8	149	10 3/4	273	13	6
T-10-LD	T-10-LP	10-ERS	5 5/16	135	5 1/16	129	5 7/8	149	12 1/2	318	14	6
T-12.5-LD	T-12.5-LP	12.5-ERS	5 5/16	135	5 1/16	129	5 7/8	149	12 1/2	318	14	6
T-25-LD	T-25-LP	25-ERS	7 15/16	202	7 1/16	179	8	203	18 19/32	472	42	19
T-65-LD	T-65-LP	65-ERS	8 13/16	224	7 15/16	202	8 3/8	213	25 3/8	645	47	21
T-100-LD	T-100-LP	100-ERS	8 13/16	224	7 15/16	202	8 3/8	213	25 3/8	645	47	21

Hilman Part #	Fits	Description	Length		Weight	
			(in)	(mm)	(lbs)	(kg)
KDH48E	ERS Series 15 - 50 ton Kits	Two Part Kit Size Handles	48	1219	11	5
H36E	ERS Series Swivel Attachments to T - 25	One Part Handle	36	914	7	3
H48E	ERS Series Swivel Attachments to T - 65	One Part Handle	48	1219	10	5
H60E	All ERS Series Swivel Attachments	One Part Handle	60	1524	24	11

ROLLERS



ENDLESS POSSIBILITIES

Our OT, NT, T Series rollers can withstand high static loading over long periods of time, often carrying the full load weight for more than a year with no adverse effects. Because loads are spread over a wide area and carried by the load plate and the contact rolls, rollers are ideal for many applications requiring the frequent movement of heavy loads.

OT, NT, T



OT, NT, T Rollers are fabricated from high strength steel. Load plates of 37.5-ton and higher capacities undergo a special machine process to minimize side-to-side movement of chain. The rollers can also be used inverted, as static conveyors.

ERF



ERF Roller have no top plate and are often used where a trunnion mount is required, where an existing "foot pad" will become the roller's top plate, or where the load has a built-in cavity mount. Used upside down, the ERF Rollers become a heavy-duty conveyor allowing the load to slide with extremely low friction.

SHD



Super Heavy Duty Rollers are the highest capacity rollers that Hilman offers as standard models. 150 & 200 Ton frames come in Long (L) or Wide (W). Wide frame versions are offered with one complete (wide) chain or with two individual chains with a center plate (C) dividing them.

LOW COEFFICIENT OF FRICTION

The combination of a hard steel load plate and the chain of concentrically ground and hardened steel rolls offer the ultimate in low friction under the proper conditions. Ideal conditions would be an evenly centered load on the rollers with a hardened steel rolling surface that is smooth, level and clear of debris. In such instances, our rollers have been tested and are between 1 and 2% coefficient of friction.



SUPERIOR WEIGHT DISTRIBUTION

This roller design creates an even load bearing area or footprint. The wide footprint spans gaps in running plates and small cracks in a floor surface, allowing for an uninterrupted move. Due to the multi-rolled concept, if a roll should break, the load won't fall because there are other contact rolls on the chain to compensate.

ADVANTAGES

These rollers come in a variety of capacities, frame and top styles. They can easily be modified for any application.

- OT** OVERSIZED TOP
Overhang side to side
- NT** NARROW TOP
Overhang front to back
- T** FLUSH TOP
Add extra strength to the frame and offer a variety of mounting capabilities
- ERF** NO TOP PLATE
Lower height and lighter weight

TOP STYLES

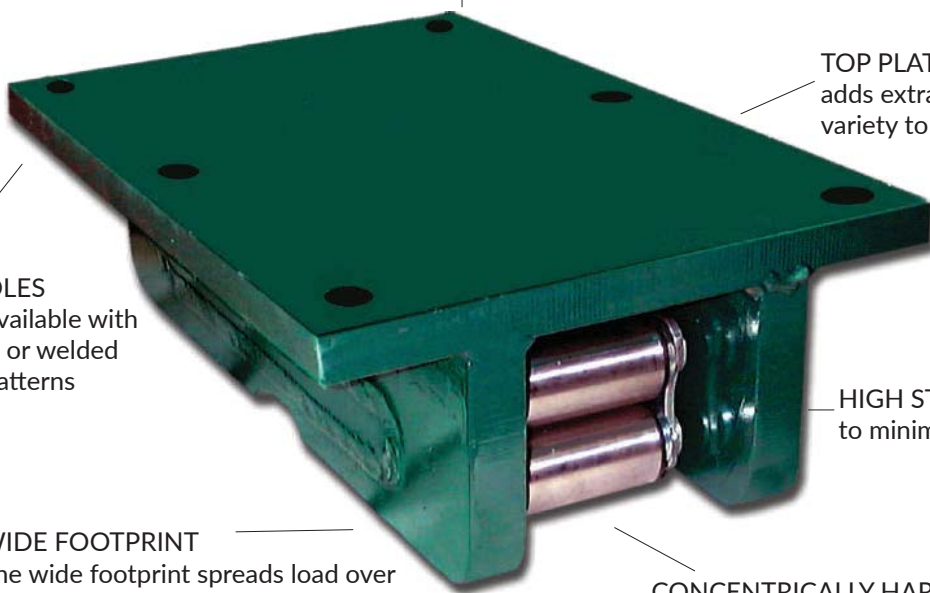

TOP PLATE
adds extra strength to the frame and variety to mounting capabilities

MOUNTING HOLES
OT and NT are available with standard bolt-on or welded mounting hole patterns

HIGH STRENGTH STEEL FRAME
to minimize side-to-side movement

WIDE FOOTPRINT
The wide footprint spreads load over greater area

CONCENTRICALLY HARDENED STEEL ROLLS
offer the ultimate in low friction under the proper conditions

EASILY MODIFIED

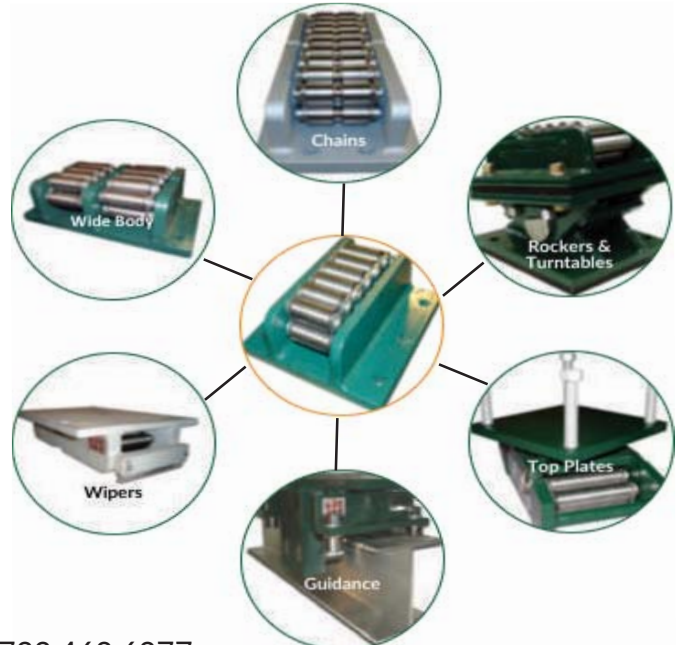

The Super Heavy Duty Rollers are the highest capacity rollers that Hilman offers as standard models. 150 & 200 Ton frames come in Long (L) or Wide (W). Wide frame versions are offered with one complete (wide) chain or with two individual chains with a center plate (C) dividing them.

XOT • XOTL • XOTW • XOTWC



	Capacity Metric Tons	<<<<<<Body Dimensions>>>>>>			<<<<<<Top Plate Dimensions>>>>>>			Contact Rolls	<<<<<<Footprint>>>>>>		Weight Lbs.(kgs)
		Length	Height	Width	Thickness	Width	Length		Roll Dia.	Roll Width	
		<<<<<<Inches (mm)>>>>>>			<<<<<<Inches (mm)>>>>>>				<<<<Inches (mm)>>>>		
100-XOT	100-tons	21.0 (533)	6.75 (171)	7.875 (200)	1.00 (25)	14.0 (356)	21.0 (533)	7	1-15/16 (49)	3-5/8 (92)	250 (113)
150-XOTL	150-tons	32.0 (813)	6.75 (171)	7.875 (200)	1.00 (25)	14.0 (356)	32.0 (813)	11	1-15/16 (49)	3-5/8 (92)	381 (172)
150-XOTW	150-tons	21.0 (533)	6.75 (171)	9.875 (251)	1.00 (25)	16.0 (406)	21.0 (533)	14	1-15/16 (49)	2-3/4 (70)	299 (136)
200-XOTL	200-tons	36.0 (914)	6.75 (171)	7.875 (200)	1.00 (25)	14.0 (356)	36.0 (914)	14	1-15/16 (49)	3-5/8 (92)	443 (201)
200-XOTW	200-tons	21.0 (533)	6.75 (171)	11.5625 (294)	1.00 (25)	21.0 (533)	21.0 (533)	14	1-15/16 (49)	3-5/8 (92)	364 (165)
200-XOTWC	200-tons	21.0 (533)	6.75 (171)	14.5 (368)	1.00 (25)	21.0 (533)	21.0 (533)	14	1-15/16 (49)	3-5/8 (92)	423 (192)
300-XOT	300-tons	34.0 (864)	10.0 (254)	10.75 (273)	1.50 (38)	21.0 (533)	34.0 (864)	8	2-15/16 (74)	5 (127)	849 (385)
500-XOT	500-tons	34.0 (864)	10.0 (254)	20.0 (508)	1.50 (38)	30.0 (762)	34.0 (864)	16	2-15/16 (74)	5 (127)	1430 (649)
750-XOT	750-tons	34.0 (864)	10.0 (254)	27.5 (699)	1.50 (38)	37.5 (953)	34.0 (864)	24	2-15/16 (74)	5 (127)	2044 (927)
1000-XOT	1000-tons	*****CONSULT FACTORY FOR SPECIFICATIONS AND WEIGHT*****									

XNT • XNTL • XNTW • XNTWC



	Capacity Metric Tons	<<<<<<Body Dimensions>>>>>>			<<<<<<Top Plate Dimensions>>>>>>			Contact Rolls	<<<<<<Footprint>>>>>>		Weight Lbs.(kgs)
		Length	Height	Width	Thickness	Width	Length		Roll Dia.	Roll Width	
		<<<<<<Inches (mm)>>>>>>			<<<<<<Inches (mm)>>>>>>				<<<<Inches (mm)>>>>		
100-XNT	100-tons	21.0 (533)	6.75 (171)	7.875 (200)	1.00 (25)	7.875 (200)	27.0 (686)	7	1-15/16 (49)	3-5/8 (92)	228 (103)
150-XNTL	150-tons	32.0 (813)	6.75 (171)	7.875 (200)	1.00 (25)	7.875 (200)	38.0 (965)	11	1-15/16 (49)	3-5/8 (92)	341 (155)
150-XNTW	150-tons	21.0 (533)	6.75 (171)	9.875 (251)	1.00 (25)	9.875 (251)	27.0 (686)	14	1-15/16 (49)	2-3/4 (70)	280 (127)
200-XNTL	200-tons	36.0 (914)	6.75 (171)	7.875 (200)	1.00 (25)	7.875 (200)	42.0 (1067)	14	1-15/16 (49)	3-5/8 (92)	396 (180)
200-XNTW	200-tons	21.0 (533)	6.75 (171)	11.5625 (294)	1.00 (25)	11.5625 (294)	27.0 (686)	14	1-15/16 (49)	3-5/8 (92)	333 (151)
200-XNTWC	200-tons	21.0 (533)	6.75 (171)	14.5 (368)	1.00 (25)	14.5 (368)	27.0 (686)	14	1-15/16 (49)	3-5/8 (92)	408 (185)
300-XNT	300-tons	34.0 (864)	10.0 (254)	10.75 (273)	1.50 (38)	10.75 (273)	42.0 (1067)	8	2-15/16 (74)	5 (127)	739(335)
500-XNT	500-tons	34.0 (864)	10.0 (254)	20.0 (508)	1.50 (38)	20.0 (508)	42.0 (1067)	16	2-15/16 (74)	5 (127)	1355 (615)
750-XNT	750-tons	34.0 (864)	10.0 (254)	27.5 (699)	1.50 (38)	27.5 (699)	42.0 (1067)	24	2-15/16 (74)	5 (127)	2009 (911)
1000-XNT	1000-tons	*****CONSULT FACTORY FOR SPECIFICATIONS AND WEIGHT*****									

XT • XTL • XTW • XTWC



	Capacity Metric Tons	<<<<<<Body Dimensions>>>>>>			<<<<<<Top Plate Dimensions>>>>>>			Contact Rolls	<<<<<<Footprint>>>>>>		Weight Lbs.(kgs)
		Length	Height	Width	Thickness	Width	Length		Roll Dia.	Roll Width	
		<<<<<<Inches (mm)>>>>>>			<<<<<<Inches (mm)>>>>>>				<<<<Inches (mm)>>>>		
100-XT	100-tons	21.0 (533)	6.75 (171)	7.875 (200)	1.00 (25)	7.875 (200)	21.0 (533)	7	1-15/16 (49)	3-5/8 (92)	217 (98)
150-XTL	150-tons	32.0 (813)	6.75 (171)	7.875 (200)	1.00 (25)	7.875 (200)	32.0 (813)	11	1-15/16 (49)	3-5/8 (92)	329 (149)
150-XTW	150-tons	21.0 (533)	6.75 (171)	9.875 (251)	1.00 (25)	9.875 (251)	21.0 (533)	14	1-15/16 (49)	2-3/4 (70)	265 (120)
200-XTL	200-tons	36.0 (914)	6.75 (171)	7.875 (200)	1.00 (25)	7.875 (200)	36.0 (914)	14	1-15/16 (49)	3-5/8 (92)	384 (174)
200-XTW	200-tons	21.0 (533)	6.75 (171)	11.5625 (294)	1.00 (25)	11.5625 (294)	21.0 (533)	14	1-15/16 (49)	3-5/8 (92)	313 (142)
200-XTWC	200-tons	21.0 (533)	6.75 (171)	14.5 (368)	1.00 (25)	14.5 (368)	21.0 (533)	14	1-15/16 (49)	3-5/8 (92)	387 (175)
300-XT	300-tons	34.0 (864)	10.0 (254)	10.75 (273)	1.50 (38)	10.75 (273)	34.0 (864)	8	2-15/16 (74)	5 (127)	706 (320)
500-XT	500-tons	34.0 (864)	10.0 (254)	20.0 (508)	1.50 (38)	20.0 (508)	34.0 (864)	16	2-15/16 (74)	5 (127)	1290 (585)
750-XT	750-tons	34.0 (864)	10.0 (254)	27.5 (699)	1.50 (38)	27.5 (699)	34.0 (864)	24	2-15/16 (74)	5 (127)	1892 (858)
1000-XT	1000-tons	*****CONSULT FACTORY FOR SPECIFICATIONS AND WEIGHT*****									

OTB, NTB, TB

You can purchase a standard OTB/NTB/TB Series roller for which a separate, bolt-on style Accu-Roll Guidance System may be added at some point in the future. Note that these models do not come standard with any guidance system. These models can be particularly handy for users who frequently need to change the type of track that the rollers will ride upon. The NTB models have longer top plates than their NT counterparts to prevent interference when mounting the load to the top plate.

These Accu-Roll System B, bolt onto a backing block attached to a Hilman Roller (OTB, NTB, AND TB Series). This gives users the flexibility to adapt to more than one track or channel, or to remove the Accu-Roll entirely. There are adjustable version, quick-release versions and versions that are available in different materials to fit almost every application requirements.

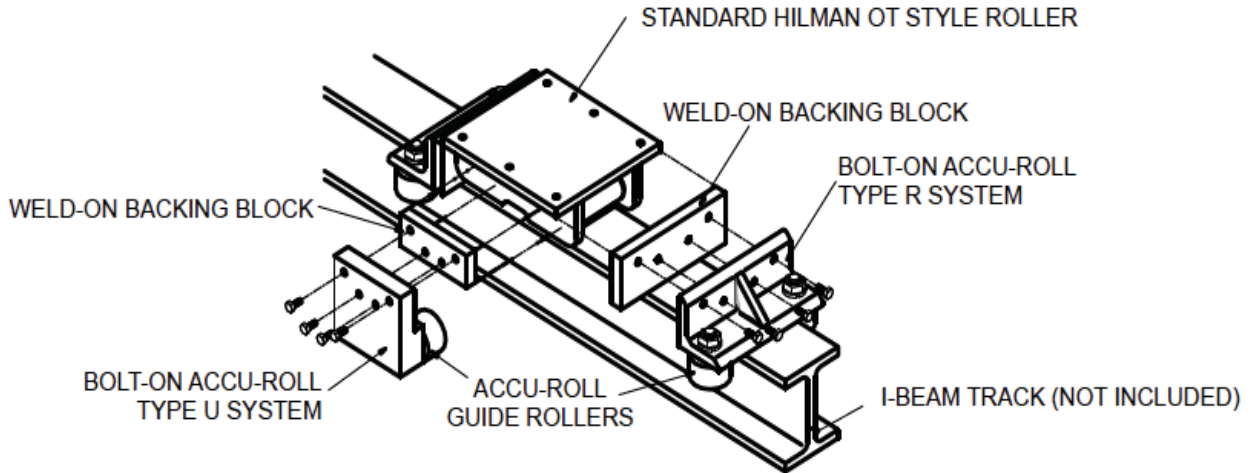

OTB



NTB



TB



	Capacity Metric Tons	Body Dimensions			Top Plate Dimensions			Contact Rolls	Footprint		Weight lbs.(kgs)
		Length	Height*	Width	Thickness	Width	Length		Roll Dia.	Roll Width	
		Inches (mm)			Inches (mm)				Inches (mm)		
5-OTB	5-tons	9.0 (229)	3.125 (79)	4.5625 (116)	.375 (10)	8.0 (203)	8.0 (203)	5	0.9375 (24)	2.4375 (62)	24 (11)
8-OTB	8-tons	9.0 (229)	3.125 (79)	5.3125 (135)	.375 (10)	8.0 (203)	8.0 (203)	5	0.9375 (24)	3.3125 (84)	27 (12)
15-OTB	15-tons	12.125 (308)	3.875 (98)	5.3125 (135)	.625 (16)	10.0 (254)	10.625 (270)	5	1.1875 (30)	2.75 (70)	52 (24)
20-OTB	20-tons	12.125 (308)	3.875 (98)	6.5625 (167)	.625 (16)	10.0 (254)	10.625 (270)	5	1.1875 (30)	4.0 (102)	60 (27)
37.5-OTB	37.5-tons	17.0 (432)	5.5 (140)	7.25 (184)	.75 (19)	12.0 (305)	15.0 (381)	5	1.625 (41)	3.5 (89)	132 (60)
50-OTB	50-tons	20.5 (521)	5.5 (140)	7.25 (184)	.75 (19)	12.0 (305)	18.5 (470)	7	1.625 (41)	3.5 (89)	166 (75)
75-OTB	75-tons	23.0 (584)	6.75 (171)	7.375 (187)	1.00 (25)	14.0 (356)	21.0 (533)	7	1.9375 (49)	3.625 (92)	250 (113)
5-NTB	5-tons	9.0 (229)	3.125 (79)	4.5625 (116)	.375 (10)	4.5 (114)	14.25 (362)	5	0.9375 (24)	2.4375 (62)	24 (11)
8-NTB	8-tons	9.0 (229)	3.125 (79)	5.3125 (135)	.375 (10)	5.0 (127)	14.25 (362)	5	0.9375 (24)	3.3125 (84)	28 (13)
15-NTB	15-tons	12.125 (308)	3.875 (98)	5.3125 (135)	.625 (16)	5.0 (127)	17.25 (438)	5	1.1875 (30)	2.75 (70)	49 (22)
20-NTB	20-tons	12.125 (308)	3.875 (98)	6.5625 (167)	.625 (16)	6.5 (165)	17.25 (438)	5	1.1875 (30)	4.0 (102)	62 (28)
37.5-NTB	37.5-tons	17.0 (432)	5.5 (140)	7.25 (184)	.75 (19)	7.0 (178)	24.5 (622)	5	1.625 (41)	3.5 (89)	131 (59)
50-NTB	50-tons	20.5 (521)	5.5 (140)	7.25 (184)	.75 (19)	7.0 (178)	28.0 (711)	7	1.625 (41)	3.5 (89)	161 (73)
75-NTB	75-tons	23.0 (584)	6.75 (171)	7.375 (187)	1.00 (25)	7.5 (191)	31.5 (800)	7	1.9375 (49)	3.625 (92)	235 (107)
5-TB	5-tons	9.0 (229)	3.125 (79)	4.5625 (116)	.375 (10)	4.5 (114)	8.0 (203)	5	0.9375 (24)	2.4375 (62)	21 (10)
8-TB	8-tons	9.0 (229)	3.125 (79)	5.3125 (135)	.375 (10)	5.0 (127)	8.0 (203)	5	0.9375 (24)	3.3125 (84)	25 (11)
15-TB	15-tons	12.125 (308)	3.875 (98)	5.3125 (135)	.625 (16)	5.0 (127)	10.625 (270)	5	1.1875 (30)	2.75 (70)	43 (20)
20-TB	20-tons	12.125 (308)	3.875 (98)	6.5625 (167)	.625 (16)	6.5 (165)	10.625 (270)	5	1.1875 (30)	4.0 (102)	54 (24)
37.5-TB	37.5-tons	17.0 (432)	5.5 (140)	7.25 (184)	.75 (19)	7.0 (178)	15.0 (381)	5	1.625 (41)	3.5 (89)	117 (53)
50-TB	50-tons	20.5 (521)	5.5 (140)	7.25 (184)	.75 (19)	7.0 (178)	18.5 (470)	7	1.625 (41)	3.5 (89)	147 (67)
75-TB	75-tons	23.0 (584)	6.75 (171)	7.375 (187)	1.00 (25)	7.5 (191)	21.0 (533)	7	1.9375 (49)	3.625 (92)	213 (97)

*Height includes Top Plate Thickness

SHDB Series rollers (XOTB, XOTLB, XOTWB, XOTWC, XNTB, XNTLB, XNTWB, XNTWCB, TB, XTB, XTLB, XTWB, XTWCB) are also available. Please contact us for specifications.

ACCU-ROLL

Hilman's Accu-Roll Guidance System is a positive external alignment system. Most often used on OT/NT/T and SHD Series Hilman Rollers, Accu-Roll can be added to any Hilman Roller and custom designed to interface with almost any type of track. Common tracks are I-beams, Wide-flanged beams, channels, rails, steel flat bars, tubes and trenches. Accu-Roll Systems are an ideal solution where load alignment is critical, a close tolerance must be maintained, where load movement is repetitive or where dynamic uplift prevention is desired.

Because there are virtually thousands of possibilities with regards to tracks, each Accu-Roll System is custom designed and built to fit the chosen track. Once the track size has been selected and the preferred width and depth locations for the Accu-Roll guides known; drawings are prepared for customer approval.

Accu-Roll Systems may have one to four or more guide rolls per roller to guide on the track or to insure that the rollers follow the intended path of travel. Normally designed to withstand a maximum of 20% of the vertical load in side-force; higher or lower capacities can be designed.



Type R - Type U



Type C



Type U

Track Type	Accu-Roll Type	Application Guidelines
<ul style="list-style-type: none"> • I-Beam • Tube • Bar • Rail 	<p>Type R</p> <p>STRAIGHT ANGLE</p>	<ul style="list-style-type: none"> • Most common system for guidance on OUTSIDE of track • Can consist of one to four Accu-Rolls, mounted to Roller • Ideal for any system, permanent or temporary Flat bar mounted to factory floor provides low height, accessible rolling system with minimal floor surface obstacles
<ul style="list-style-type: none"> • Fabricated Track • Channel 	<p>Type C</p> <p>STRAIGHT ANGLE</p>	<ul style="list-style-type: none"> • Common System for Guidance INSIDE a track or a track imbedded in concrete floor • Can consist of one to four Accu-Rolls; two can be installed on one end or on one side, or in center of Roller frame side • Track can be standard channel, inside flanges of H-Beam, fabricated track from back-to-back angles, etc.
<ul style="list-style-type: none"> • Uplift 	<p>Type RU</p> <p>STRAIGHT ANGLE</p>	<ul style="list-style-type: none"> • Most often added to Type R System • Can consist of one or more Accu-Rolls per side • Prevents UPLIFT in dynamic condition • Resistance against wind and buoyancy • Protection against overturning moment • Aids in moving top-heavy or eccentrically loaded equipment

MODIFICATIONS

TOP MODIFICATIONS

Modifications to the top plates of Hilman Rollers can range greatly. Some relatively simple top modifications might be special drilled and tapped hole patterns, connecting studs or tops machined to close tolerances. Top clamps, hinged adaptations or container fittings can be added to the rollers, as well as other types of attachments, for the purpose of mounting to a specific type of footing or pad. Below are several examples.



CHAIN MODIFICATIONS

There are several different modifications that Hilman can do to the chains. Tapered roller chains allow Hilman Rollers to follow a fixed radius. Keyway chains are an internal guidance feature to maximize chain life. In highly repetitive applications or where rollers encounter bursts of speed; the Keyway feature keeps the chain centered in the roller frame. Concave and Convex chain and frame solutions are also possible. Hilman can even design specially contoured chain where the rolls are machined to match the contour of crowned rails, ensuring sufficient contact area.



FRAME MODIFICATIONS

Roller frames and tops can be modified in any number of ways to suit specific requirements. Special materials can be used for corrosive resistant or non sparking applications. Mounting surfaces can have custom hole patterns or machined finishes.

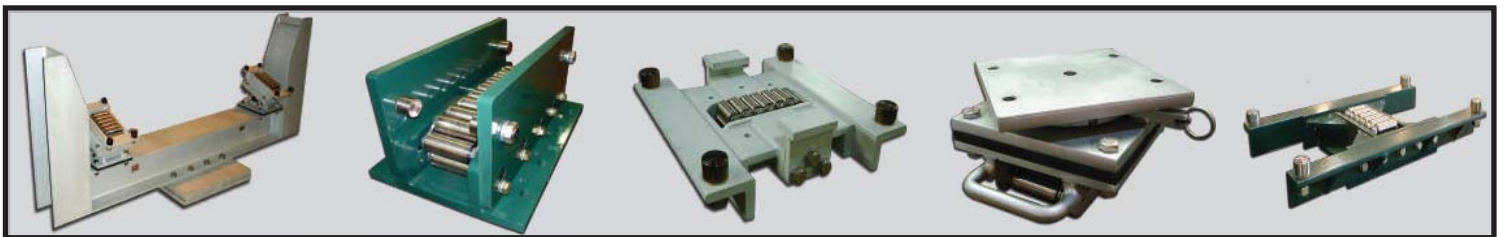

TRACK WIPERS OR DIRT SHIELDS

Many wiper and shield styles can be added to Rollers for use in extremely dirty or abusive conditions to minimize the exposure of dirt and dust to the roller chain.



MODIFICATIONS

SPECIAL MATERIALS & COATINGS

Many different alloys and coatings are available for making Hilman rollers meet the requirements of different applications. Alloys to resist varying levels of corrosion, high heat, and non-sparking conditions are just some of what is available for the chain assembly. Special coatings, paint finishes, galvanizing processes or platings can be applied to help in a variety of environments. Hilman typically uses the highest grade alloys and stainless steels available to insure that the rollers operate continuously in the manner intended.



OTHER MODIFICATIONS

Hilman's extensive experience in custom modifications of rollers and rolling systems design covers a broad spectrum of applications. Below are some of our more elaborate modifications.



TRACKMATE



TRACKMATE

Hilman TrackMate dollies are an excellent method for increasing productivity in assembly and manufacturing applications, where heavy loads are moved from station to station for various stages of build-up.

TRACKMATE



Dual flanged, self-guiding Dolly that is an ideal solution for frequent load moving in many assembly and production line operations. Suited for applications requiring repetitive straight-line load moves.

Low Profile. Self-Guided.

The rolls carry the full load during movement, while dual flanges guide along the outer edges of a flat bar steel track, to ensure proper alignment. Their low profile keeps the workplace safe and their low friction means a smoother move with less downtime.



Custom Tops, Frames & Turntables

Dollies can be easily modified in any number of ways, including custom tops for mounting/fastening to the load, brush-wiper systems to clear debris from the track and custom shaped steel frames to suit your application requirements. Hilman can also design and supply the steel flat bar tracks, and track-turntables in case you need to make turn, for a complete system. Turntables can be integrated directly into an assembly line track system. The turntables are utilized to accommodate 90 degree turns in the path of production and potentially divert a module to an additional set of workstations. Manual and automated turntables are both available design options.



ADVANTAGES

With capacities up to 20-tons, standard TrackMate Dollies are offered in rectangular shape, with two types of tops; Swivel or Rigid.

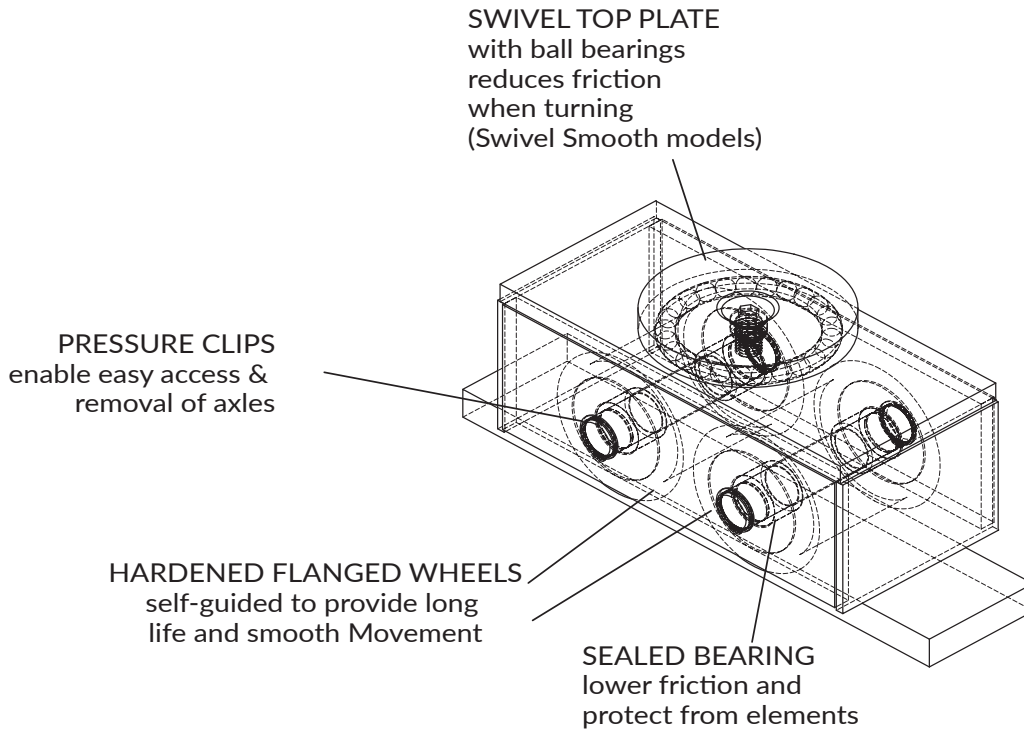

Specifications

TMS TrackMate Swivel Smooth Rectangle

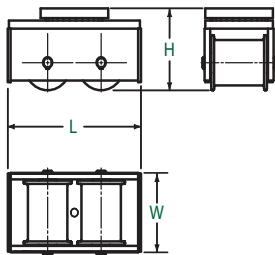

TMR TrackMate Rigid Smooth Rectangle

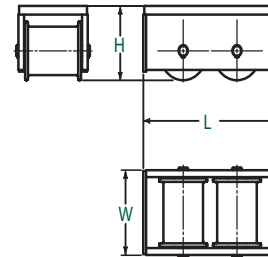

Swivel Style					
Product	Capacity	Height	Width	Length	Weight
2.5-TMS	2.5-tons	4.53" / 115 mm	6.13" / 156 mm	9.31" / 237 mm	29 lb / 13 kg
5-TMS	5-tons	6.32" / 161 mm	6.13" / 156 mm	11.81" / 300 mm	63 lb / 29 kg
10-TMS	10-tons	6.82" / 174 mm	6.13" / 156 mm	13.31" / 338 mm	76 lb / 34 kg
20-TMS	20-tons	7.69" / 196 mm	6.63" / 168 mm	15.56" / 395 mm	119 lb / 54 kg
Rigid Style					
Product	Capacity	Height	Width	Length	Weight
2.5-TMR	2.5-tons	3.60" / 92 mm	6.13" / 156 mm	9.31" / 237 mm	28 lb / 13 kg
5-TMR	5-tons	5.38" / 137 mm	6.13" / 156 mm	11.81" / 300 mm	57 lb / 26 kg
10-TMR	10-tons	5.88" / 150 mm	6.13" / 156 mm	13.31" / 338 mm	70 lb / 32 kg
20-TMR	20-tons	6.75" / 172 mm	6.63" / 168 mm	15.56" / 395 mm	113 lb / 51 kg

BULL DOLLY



BULL DOLLY

The Hilman Bull Dolly Series are a lightweight, cost effective solution for moving heavy equipment such as large safes, chillers, condensers and other machinery.

1-6 TONS



Lightweight, Cost Effective- Offers different wheel options to protect floors and a variety of top styles for straight moving or turning.

9-18 TONS



Higher Capacity, Large Footprint - allows user to spread the load over greater area up to 18 tons!

4-72 TON KITS



Prepackaged Kits - come equipped with everything needed to move heavy equipment with ease!



FLOOR PROTECTION

Polyurethane and Nylon wheel options are non-marking and can be used on a variety of floor surfaces.

MAINTENANCE FRIENDLY

Our dollies have very few moving parts minimizing maintenance requirements.

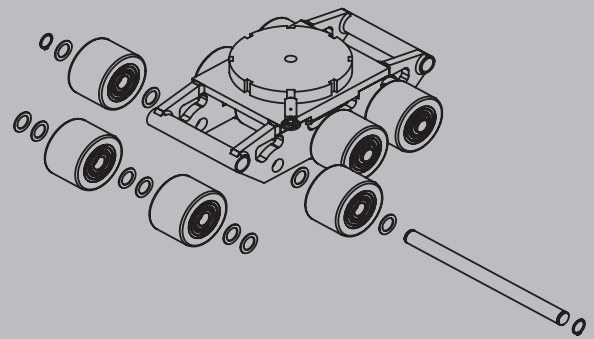

EASY TO MANEUVER

Bull Dollies are ideal for positioning and moving heavy loads either in a straight line or where turns are needed.

ADVANTAGES

Choose Rigid for straight or Swivel for easy turning.

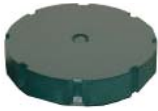

SMOOTH STEEL TOPS (S)
ideal for weld-mounting the rollers to equipment or as a base unit for a variety of top modifications.



PADDED STEEL TOPS (P)
allow some compression and provide a non-slip surface for moving on less than perfect floors.



DIAMOND STEEL TOP (D)
spike-like steel grid able to grip into wood and provide a secure move for crated or palletized equipment.

VERSATILE TOP PLATES



LOW PROFILE

NON-MARKING WHEELS

LOCK
enables the units to be used as swivel or rigid top dollies

MAINTENANCE FRIENDLY
wheel & axle design has very few moving parts for easy maintenance

WHEEL OPTIONS



NYLON WHEELS
for good floor protection and favorable wear. They will not "set" if left under load (static) for a period of time



POLY WHEELS
are a softer wheel that provide excellent floor protection on tile floors



STEEL WHEELS
provide the best wear characteristics and are great for durable floors

LARGER FOOTPRINT
to spread the load over greater area and offers stability and ease of turning



MULTI-FUNCTIONAL HANDLE
for pulling

HANDLE & ALIGNMENT BAR
larger models have a handle for pulling or you can use a standard 1 inch alignment bar to stabilize heavy loads or connect multiple dollies



KITS

Lightweight, Cost Effective – easy to maneuver heavy equipment such as large safes, chillers, condensers and machinery.

KBSP-24P



KBSS-12S



KBSD-4N



Product Number	Kit Capacity	Dolly Capacity	Top Style Description	Roller Material	Kits Include	Weight lbs.	Weight kgs.
KBRD-4N	4 ton	1 ton	Rigid Diamond	Nylon	(4) BRD-1N Dollies, (2) Handles, (4) Pre-load pads	75	34
KBRD-4P	4 ton	1 ton	Rigid Diamond	Polyurethane	(4) BRD-1P Dollies, (2) Handles, (4) Pre-load pads	75	34
KBRD-4S	4 ton	1 ton	Rigid Diamond	Steel	(4) BRD-1S Dollies, (2) Handles, (4) Pre-load pads	75	34
KBSP-4N	4 ton	1 ton	Swivel Padded	Nylon	(4) BSP-1N Dollies, (2) Handles	85	39
KBSP-4P	4 ton	1 ton	Swivel Padded	Polyurethane	(4) BSP-1P Dollies, (2) Handles	85	39
KBSP-4S	4 ton	1 ton	Swivel Padded	Steel	(4) BSP-1S Dollies, (2) Handles	85	39
KBSD-4N	4 ton	1 ton	Swivel Diamond	Nylon	(4) BSD-1N Dollies, (2) Handles, (4) Pre-load pads	83	38
KBSD-4P	4 ton	1 ton	Swivel Diamond	Polyurethane	(4) BSD-1P Dollies, (2) Handles, (4) Pre-load pads	83	38
KBSD-4S	4 ton	1 ton	Swivel Diamond	Steel	(4) BSD-1S Dollies, (2) Handles, (4) Pre-load pads	83	38
KBRD-12N	12 ton	3 ton	Rigid Diamond	Nylon	(4) BRD-3N Dollies, (2) Handles, (4) Pre-load pads	91	41
KBRD-12P	12 ton	3 ton	Rigid Diamond	Polyurethane	(4) BRD-3P Dollies, (2) Handles, (4) Pre-load pad	91	41
KBRD-12S	12 ton	3 ton	Rigid Diamond	Steel	(4) BRD-3S Dollies, (2) Handles, (4) Pre-load pads	91	41
KBSP-12N	12 ton	3 ton	Swivel Padded	Nylon	(4) BSP-3N Dollies, (2) Handles	100	45
KBSP-12P	12 ton	3 ton	Swivel Padded	Polyurethane	(4) BSP-3P Dollies, (2) Handles	100	45
KBSP-12S	12 ton	3 ton	Swivel Padded	Steel	(4) BSP-3S Dollies, (2) Handles	100	45
KBSD-12N	12 ton	3 ton	Swivel Diamond	Nylon	(4) BSD-3N Dollies, (2) Handles, (4) Pre-load pads	102	46
KBSD-12P	12 ton	3 ton	Swivel Diamond	Polyurethane	(4) BSD-3P Dollies, (2) Handles, (4) Pre-load pads	102	46
KBSD-12S	12 ton	3 ton	Swivel Diamond	Steel	(4) BSD-3S Dollies, (2) Handles, (4) Pre-load pads	102	46
KBSS-12N	12 ton	3 ton	Swivel Smooth	Nylon	(4) BSS-3N Dollies, (2) Handles	102	46
KBSS-12P	12 ton	3 ton	Swivel Smooth	Polyurethane	(4) BSS-3P Dollies, (2) Handles	102	46
KBSS-12S	12 ton	3 ton	Swivel Smooth	Steel	(4) BSS-3S Dollies, (2) Handles	102	46
KBRD-24N	24 ton	6 ton	Rigid Diamond	Nylon	(4) BRD-6N Dollies, (2) Handles, (4) Pre-load pads	196	89
KBRD-24P	24 ton	6 ton	Rigid Diamond	Polyurethane	(4) BRD-6P Dollies, (2) Handles, (4) Pre-load pads	196	89
KBRD-24S	24 ton	6 ton	Rigid Diamond	Steel	(4) BRD-6S Dollies, (2) Handles, (4) Pre-load pads	196	89
KBSP-24N	24 ton	6 ton	Swivel Padded	Nylon	(4) BSP-6N Dollies, (2) Handles	216	98
KBSP-24P	24 ton	6 ton	Swivel Padded	Polyurethane	(4) BSP-6P Dollies, (2) Handles	216	98
KBSP-24S	24 ton	6 ton	Swivel Padded	Steel	(4) BSP-6S Dollies, (2) Handles	216	98
KBSD-24N	24 ton	6 ton	Swivel Diamond	Nylon	(4) BSD-6N Dollies, (2) Handles, (4) Pre-load pads	21	98
KBSD-24P	24 ton	6 ton	Swivel Diamond	Polyurethane	(4) BSD-6P Dollies, (2) Handles, (4) Pre-load pads	216	98
KBSD-24S	24 ton	6 ton	Swivel Diamond	Steel	(4) BSD-6S Dollies, (2) Handles, (4) Pre-load pads	216	98
KBSS-24N	24 ton	6 ton	Swivel Smooth	Nylon	(4) BSS-6N Dollies, (2) Handles	213	97
KBSS-24P	24 ton	6 ton	Swivel Smooth	Polyurethane	(4) BSS-6P Dollies, (2) Handles	213	97
KBSS-24S	24 ton	6 ton	Swivel Smooth	Steel	(4) BSS-6S Dollies, (2) Handles	213	97

INDIVIDUAL

Bull Dollies are ideal for positioning and moving heavy loads either in a straight line or where turns are needed.

Offers different wheel options to protect floors and a variety of top styles for straight moving (Rigid) or turning (Swivel).

Rigid Diamond



Product Number	Roller Capacity	Top Style Description	Roller Material	Height inches	Height mm	Width inches	Width mm	Length inches	Length mm	Weight lbs.	Weight kg
BRD-1N	1 ton	Rigid Diamond	Nylon	4	102	4.43	113	6.5	165	9	4
BRD-1P	1 ton	Rigid Diamond	Polyurethane	4	102	4.43	113	6.5	165	9	4
BRD-1S	1 ton	Rigid Diamond	Steel	4	102	4.43	113	6.5	165	9	4
BRD-3N	3 ton	Rigid Diamond	Nylon	4.36	111	5.23	133	8	203	13	6
BRD-3P	3 ton	Rigid Diamond	Polyurethane	4.36	111	5.23	133	8	203	13	6
BRD-3S	3 ton	Rigid Diamond	Steel	4.36	111	5.23	133	8	203	13	6
BRD-6N	6 ton	Rigid Diamond	Nylon	4.45	113	10	254	11	279	34	15
BRD-6P	6 ton	Rigid Diamond	Polyurethane	4.45	113	10	254	11	279	34	15
BRD-6S	6 ton	Rigid Diamond	Steel	4.45	113	10	254	11	279	34	15

Swivel Diamond



BSD-1N	1 ton	Swivel Diamond	Nylon	4.43	113	4.43	113	6.5	165	11	5
BSD-1P	1 ton	Swivel Diamond	Polyurethane	4.43	113	4.43	113	6.5	165	11	5
BSD-1S	1 ton	Swivel Diamond	Steel	4.43	113	4.43	113	6.5	165	11	5
BSD-3N	3 ton	Swivel Diamond	Nylon	4.79	122	5.23	133	8	203	16	7
BSD-3P	3 ton	Swivel Diamond	Polyurethane	4.79	122	5.23	133	8	203	16	7
BSD-3S	3 ton	Swivel Diamond	Steel	4.79	122	5.23	133	8	203	16	7
BSD-6N	6 ton	Swivel Diamond	Nylon	5.1	129	10	254	11	279	39	18
BSD-6P	6 ton	Swivel Diamond	Polyurethane	5.1	129	10	254	11	279	39	18
BSD-6S	6 ton	Swivel Diamond	Steel	5.1	129	10	254	11	279	39	18

Swivel Padded



BSP-1N	1 ton	Swivel Padded	Nylon	4.99	127	4.43	113	6.5	165	12	5
BSP-1P	1 ton	Swivel Padded	Polyurethane	4.99	127	4.43	113	6.5	165	12	5
BSP-1S	1 ton	Swivel Padded	Steel	4.99	127	4.43	113	6.5	165	12	5
BSP-3N	3 ton	Swivel Padded	Nylon	5.35	136	5.23	133	8	203	15	7
BSP-3P	3 ton	Swivel Padded	Polyurethane	5.35	136	5.23	133	8	203	15	7
BSP-3S	3 ton	Swivel Padded	Steel	5.35	136	5.23	133	8	203	15	7
BSP-6N	6 ton	Swivel Padded	Nylon	6.6	142	10	254	11	279	39	18
BSP-6P	6 ton	Swivel Padded	Polyurethane	6.6	142	10	254	11	279	39	18
BSP-6S	6 ton	Swivel Padded	Steel	6.6	142	10	254	11	279	39	18

Swivel Smooth



BSS-3N	3 ton	Swivel Smooth	Nylon	4.79	122	5.23	133	8	203	16	7
BSS-3P	3 ton	Swivel Smooth	Polyurethane	4.79	122	5.23	133	8	203	16	7
BSS-3S	3 ton	Swivel Smooth	Steel	4.79	122	5.23	133	8	203	16	7
BSS-6N	6 ton	Swivel Smooth	Nylon	4.85	123	10	254	11	279	38	17
BSS-6P	6 ton	Swivel Smooth	Polyurethane	4.85	123	10	254	11	279	38	17
BSS-6S	6 ton	Swivel Smooth	Steel	4.85	123	10	254	11	279	38	17

Note: All Swivel Top Styles Include Locks

HIGH CAPACITY

9, 12 and 18 ton models have a larger footprint to spread the weight of the load over greater area.



INDIVIDUAL

Product Number	Roller Capacity	Top Style Description	Roller Material	Height		Width		Length		Weight	
				inches	mm	inches	mm	inches	mm	lbs.	kg
BRD-9P	9 ton	Rigid Diamond	Polyurethane	5.755	146	8.125	206	18.32	465	76	34
BSS-9P	9 ton	Swivel Smooth	Polyurethane	6.75	171	8.125	206	18.32	465	84	38
BSP-9P	9 ton	Swivel Padded	Polyurethane	6.75	171	8.125	206	18.32	465	85	39
BRD-12P	12 ton	Rigid Diamond	Polyurethane	5.755	146	8.125	206	18.32	465	87	39
BSS-12P	12 ton	Swivel Smooth	Polyurethane	6.75	171	8.125	206	18.32	465	95	43
BSP-12P	12 ton	Swivel Padded	Polyurethane	6.75	171	8.125	206	18.32	465	96	44
BRD-18P	18 ton	Rigid Diamond	Polyurethane	5.755	146	8.125	206	18.32	465	111	50
BSS-18P	18 ton	Swivel Smooth	Polyurethane	6.75	171	8.125	206	18.32	465	118	54
BSP-18P	18 ton	Swivel Padded	Polyurethane	6.75	171	8.125	206	18.32	465	120	54



SETS

Product Number	Set Capacity	Dolly Capacity	Top Style Description	Roller Material	Set Includes
RS-BRP-36P	36 ton	9 ton	Swivel Padded	Polyurethane	(4) BSP-9P Dollies, (2) Handles
RS-BSP-48P	48 ton	12 ton	Swivel Padded	Polyurethane	(4) BSP-12P Dollies, (2) Handles
RS-BSP-72P	72 ton	18 ton	Swivel Padded	Polyurethane	(4) BSP-18P Dollies, (2) Handles

Our larger dollies also feature a multi-functional carrying handle that can not only be used to position the unit, but can also fit an optional standard 1 inch alignment bar to stabilize heavy loads.



MODIFIED

Bull Dollies can be modified in a number of ways to meet specific project needs. From frame size to wheel elevation, Hilman can make a complete solution for you.

WIPERS & BRUSHES



FRAMES & HOLE PATTERNS



ACCU-ROLL GUIDANCE



HYDAULIC CYLINDERS



SPECIAL TOPS



ROCKER TOPS



TRI-GLIDE



TRI-GLIDE

3-POINT MOVING SYSTEM

Placing the dollies in a 3-point configuration can stabilize the rollers and prevent them from slipping out, even under pulling and tugging forces.



Using Center of Gravity, the front unit is placed under then load.



Placing the dollies where support is needed ensures the rear dollies will be kept parallel in order to track properly when moving.

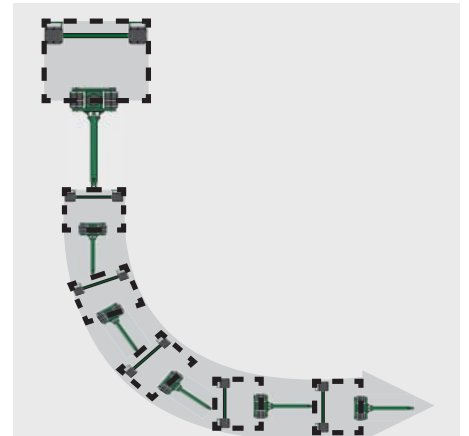

As the load is steered with the front unit, the rear dollies will follow, providing the user with a wide range of mobility.

CONFIGURATIONS

The Hilman Tri-Glide System is versatile in that the front and rear units can be combined and configured to further stabilize bulky loads.

4-Point Moving Solution
Two Rear Units with Spreader Bars

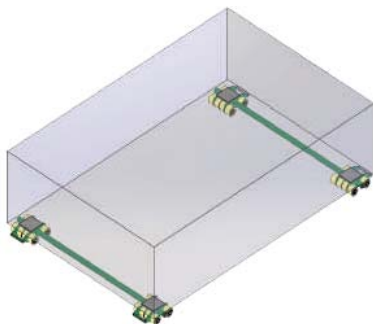

3-Point Moving Solution
One Front Unit
One Rear Unit with Spreader Bar

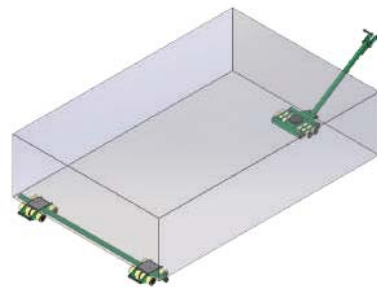

4-Point Moving Solution
Two Front Units
One Rear Unit with Spreader Bar

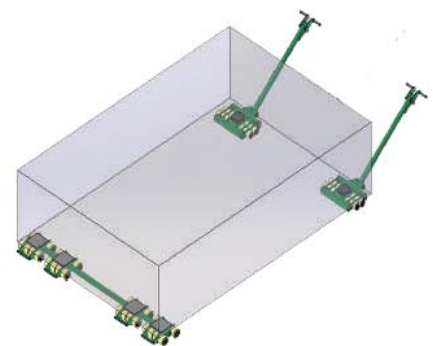

*Images are for representation purposes only. Actual product configuration and support points will differ based on the load.

ADVANTAGES

The Hilman Tri-Glide provides a stable, efficient solution for moving heavy loads. It is designed with a large footprint to spread the weight of the load over a greater area. Our Polyurethane and Nylon rollers are non-marking and can be used on a variety of floor surfaces.

Easy Maneuverability, Maintenance Friendly, Easy to Assemble, No Tools Required!

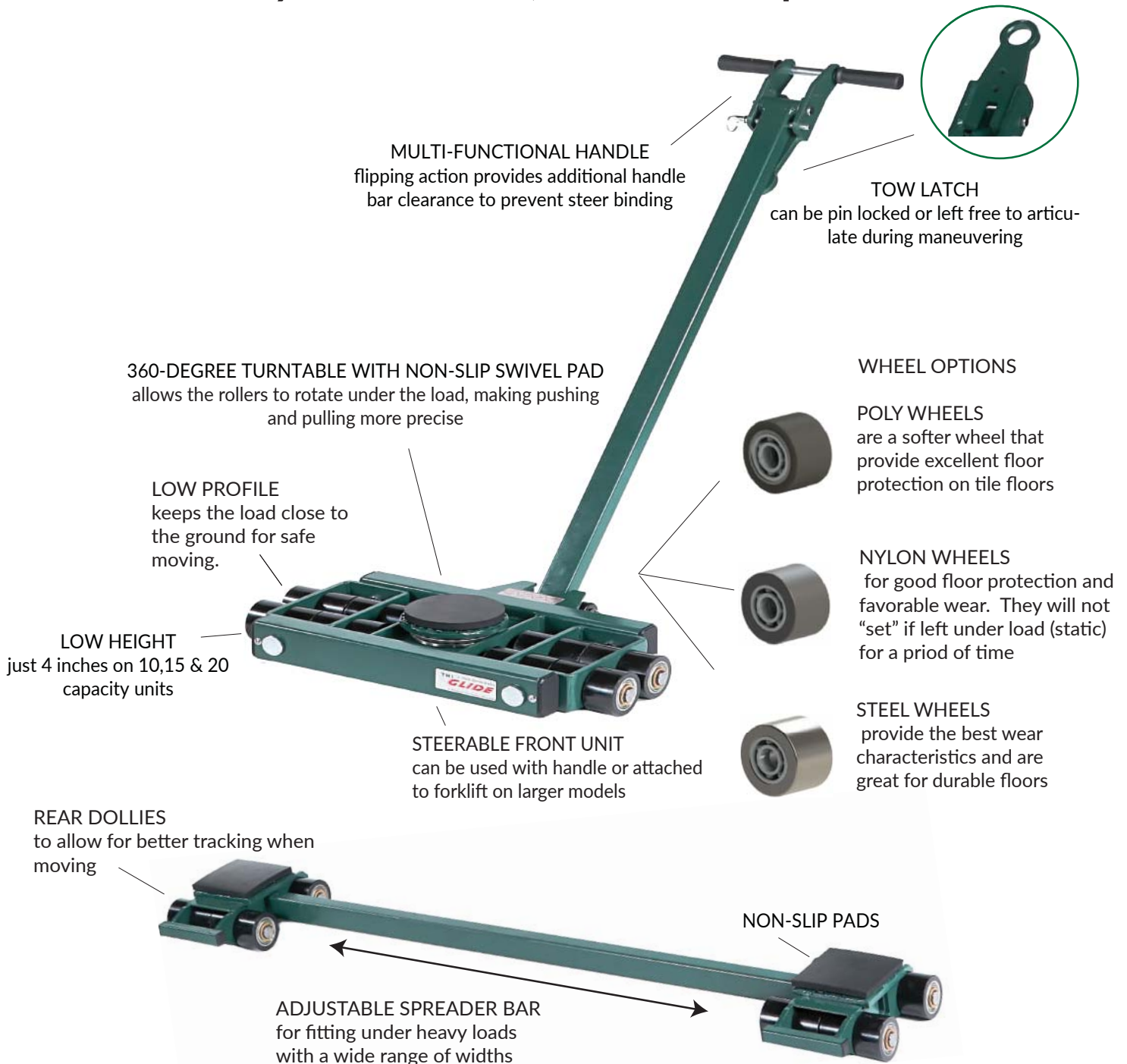

10, 15 & 20 TON

Hilman Tri-Glide components can be purchased individually to accommodate user preference. All units come with non-slip pads for the front unit and rear dollies.

LOW HEIGHT
FLOOR PROTECTION
EASY 3 POINT SYSTEM

Wheel Options



Kits

All kits include: (1) Front Unit with Handle and (2) Rear Dollies with a Spreader Bar

Hilman Part #	Capacity	Wheel Type	Wheel Count	Height (w/pad)	Height (w/o pad)	Weights (lbs.)	Handle Length	Alignment Bar
KTG-10N	10 Ton	Nylon	8/8	4.5" (114mm)	4" (102mm)	155	49.5" (1257mm)	60" (1524mm)
KTG-10P	10 Ton	Poly	8/8	4.5" (114mm)	4" (102mm)	161	49.5" (1257mm)	60" (1524mm)
KTG-10S	10 Ton	Steel	8/8	4.5" (114mm)	4" (102mm)	193	49.5" (1257mm)	60" (1524mm)
KTG-15N	15 Ton	Nylon	12/12	4.5" (114mm)	4" (102mm)	168	49.5" (1257mm)	60" (1524mm)
KTG-15P	15 Ton	Poly	12/12	4.5" (114mm)	4" (102mm)	181	49.5" (1257mm)	60" (1524mm)
KTG-15S	15 Ton	Steel	12/12	4.5" (114mm)	4" (102mm)	236	49.5" (1257mm)	60" (1524mm)
KTG-20N	20 Ton	Nylon	16/16	4.5" (114mm)	4" (102mm)	184	49.5" (1257mm)	60" (1524mm)
KTG-20P	20 Ton	Poly	16/16	4.5" (114mm)	4" (102mm)	198	49.5" (1257mm)	60" (1524mm)
KTG-20S	20 Ton	Steel	16/16	4.5" (114mm)	4" (102mm)	260	49.5" (1257mm)	60" (1524mm)

Individual Front

Includes: (1) Front Unit with a Multi-functional Handle for pulling or towing

Hilman Part #	Capacity	Type	Width (in.)	Height (w/o pad)	Height (w/pad)	Wheel Size	Roller Type	Weight (lbs)
TG-F5N	5 Ton	Front	17.875"	4" (102mm)	4.5" (114mm)	Ø3.13" (79mm)	Nylon	96
TG-F5P	5 Ton	Front	17.875"	4" (102mm)	4.5" (114mm)	Ø3.13" (79mm)	Poly	99
TG-F5S	5 Ton	Front	17.875"	4" (102mm)	4.5" (114mm)	Ø3.13" (79mm)	Steel	115
TG-F7.5N	7.5 Ton	Front	22.6875"	4" (102mm)	4.5" (114mm)	Ø3.13" (79mm)	Nylon	106
TG-F7.5P	7.5 Ton	Front	22.6875"	4" (102mm)	4.5" (114mm)	Ø3.13" (79mm)	Poly	113
TG-F7.5S	7.5 Ton	Front	22.6875"	4" (102mm)	4.5" (114mm)	Ø3.13" (79mm)	Steel	145
TG-F10N	10 Ton	Front	26.6875"	4" (102mm)	4.5" (114mm)	Ø3.13" (79mm)	Nylon	113
TG-F10P	10 Ton	Front	26.6875"	4" (102mm)	4.5" (114mm)	Ø3.13" (79mm)	Poly	120
TG-F10S	10 Ton	Front	26.6875"	4" (102mm)	4.5" (114mm)	Ø3.13" (79mm)	Steel	151

Individual Rear

Includes: (2) Rear Dollies with a Spreader Bar

Hilman Part #	Capacity	Type	Width (in.)	Height (w/o pad)	Height (w/pad)	Wheel Size	Roller Type	Weight (lbs)
TG-R5N	5 Ton	Rear	6.25"	4" (102mm)	4.5" (114mm)	Ø3.13" (79mm)	Nylon	59
TG-R5P	5 Ton	Rear	6.25"	4" (102mm)	4.5" (114mm)	Ø3.13" (79mm)	Poly	62
TG-R5S	5 Ton	Rear	6.25"	4" (102mm)	4.5" (114mm)	Ø3.13" (79mm)	Steel	78
TG-R7.5N	7.5 Ton	Rear	7.6875"	4" (102mm)	4.5" (114mm)	Ø3.13" (79mm)	Nylon	62
TG-R7.5P	7.5 Ton	Rear	7.6875"	4" (102mm)	4.5" (114mm)	Ø3.13" (79mm)	Poly	68
TG-R7.5S	7.5 Ton	Rear	7.6875"	4" (102mm)	4.5" (114mm)	Ø3.13" (79mm)	Steel	91
TG-R10N	10 Ton	Rear	9.6875"	4" (102mm)	4.5" (114mm)	Ø3.13" (79mm)	Nylon	71
TG-R10P	10 Ton	Rear	9.6875"	4" (102mm)	4.5" (114mm)	Ø3.13" (79mm)	Poly	78
TG-R10S	10 Ton	Rear	9.6875"	4" (102mm)	4.5" (114mm)	Ø3.13" (79mm)	Steel	109

24-80 Tons



Kits

All kits include: (1) Front Unit with Handle and (2) Rear Dollies with a Spreader Bar

Hilman Part #	Capacity	Wheel Type	Wheel Count	Height (w/pad)	Height (w/o pad)	Weight (lbs)	Handle Length	Alignment Bar
KTG-24P	24 Ton	Poly	8/8	5.5" (140mm)	5.25" (133mm)	384	43.75" (1162mm)	72" (1829mm)
KTG-40P	40 Ton	Poly	16/16	5.5" (140mm)	5.25" (133mm)	467	43.75" (1162mm)	72" (1829mm)

Individual Front

Includes: (1) Front Unit with a Tow Handle

Hilman Part #	Capacity	Type	Width (in.)	Height (w/pad):	Height (w/o pad):	Wheel Size	Roller Type	Weight (lbs)
TG-F12P	12 Ton	Front	26.875	5.5" (140mm)	5.25" (133mm)	Ø4.25" (108mm)	Poly	24
TG-F20P	20 Ton	Front	39.1875	5.5" (140mm)	5.25" (133mm)	Ø4.25" (108mm)	Poly	286

Individual Rear

Includes: (2) Rear Dollies with a Spreader Bar

Hilman Part #	Capacity	Type	Width (in.)	Height (w/pad):	Height (w/o pad):	Wheel Size	Roller Type	Weight (lbs)
TG-R12P	12 Ton	Rear	8.25	5.5" (140mm)	5.25" (133mm)	Ø4.25" (108mm)	Poly	135
TG-R20P	20 Ton	Rear	14.1875	5.5" (140mm)	5.25" (133mm)	Ø4.25" (108mm)	Poly	181



Kits

All kits include: (1) Front Unit with Handle and (2) Rear Dollies with a Spreader Bar

Hilman Part #	Capacity	Wheel Type	Wheel Count	Height (w/pad):	Height (w/o pad):	Weight (lbs)	Handle Length	Alignment Bar
KTG-60P	60 Ton	Poly	24/24	7.75" (197mm)	7.00" (178mm)	981	45.125" (1146mm)	96" (2438mm)
KTG-80P	80 Ton	Poly	32/32	7.75" (197mm)	7.00" (178mm)	1095	45.125" (1146mm)	96" (2438mm)

Individual Front

Includes: (1) Front Unit with a Tow Handle

Hilman Part #	Capacity	Type	Width (in.)	Height (w/pad):	Height (w/o pad):	Wheel Size	Roller Type	Weight (lbs)
TG-F30P	30 Ton	Front	48.0625	7.75" (197mm)	7.00" (178mm)	Ø5.51" (140mm)	Poly	603
TG-F40P	40 Ton	Front	56.0625	7.75" (197mm)	7.00" (178mm)	Ø5.51" (140mm)	Poly	667

Individual Rear

Includes: (2) Rear Dollies with a Spreader Bar

Hilman Part #	Capacity	Type	Width (in.)	Height (w/pad):	Height (w/o pad):	Wheel Size	Roller Type	Weight (lbs)
TG-R30P	30 Ton	Rear	17.25	7.75" (197mm)	7.00" (178mm)	Ø5.51" (140mm)	Poly	378
TG-R40P	40 Ton	Rear	21.0625	7.75" (197mm)	7.00" (178mm)	Ø5.51" (140mm)	Poly	428

Higher Tonnage available on request.

MODIFICATIONS

The Hilman Tri-Glide can be modified in a number of ways to accommodate your specific application requirements. Custom turntables and special hole patterns, on the contact points, are just a couple of examples where users have made the Hilman Tri-Glide System a perfect fit. Hilman also manufactures completely custom Tri-Glide Solutions to meet specific performance requirements.

DIAMOND SWIVEL LOCKING TOPS



LOCATOR PINS FOR REAR DOLLIES



SPECIAL CONFIGURATIONS



CUSTOM ATTACHMENTS



CARTS



HYDRAULIC CYLINDERS



OMNI-SKATE



OMNI-SKATE

The Hilman OMNI-SKATE is a multi-directional load skate capable of traveling in any direction and rotating on axis. Designed, engineered and manufactured in the USA, the OMNI-SKATE optimizes your move while being the most reliable and rugged solution in the industry.

6, 8 & 10 TONS



Omni-Skates - 360 Degree
Maneuverability - Move heavy loads in
tight spaces and around sharp corners in
any direction.

LIFT. SET. ROLL

Lift up the back end of the load first using one or two toe jacks. You can do this manually or with a hydraulic pump. If you use just one jack, lift the load directly next to the front dolly. You can also use 4 toe jacks to lift entire load simultaneously. Roll the rear dollies under the load then lower the load onto the dollies. Repeat for front dollies, remove toe jacks and you are ready to move!

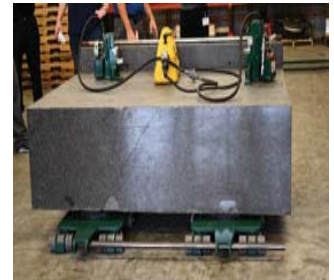

FEATURES

The Hilman OMNI-SKATE is available in capacities of 6, 8 and 10 tons. They can also be combined into sets of 4 for capacities up to 40 tons!



SPECIFICATIONS



	OMNI-6	OMNI-8	OMNI-10
LOAD CAPACITY	6 ton	8 ton	10 ton
WHEEL TYPE	NYLON	NYLON	NYLON
HEIGHT	4.63 in	4.63 in	4.63 in
WIDTH	24.125"	22.9375"	31.4375"
LENGTH	30.125"	31.375"	38.75"
WHEEL DIAMETER	Ø 3.13	Ø 3.13	Ø 3.13
NUMBER OF WHEELS	9	12	15
PAD DIAMETER	Ø 8"	Ø 8"	Ø 8"
WEIGHT	111 lb/50 kg	139 lb/63 kg	185 lb/84 kg

ACCESSORIES

Handle for pulling



Alignment Bar with Coupling



OMNI-SKATE

The Hilman Omni-Skate provides a stable, efficient solution for moving heavy loads.

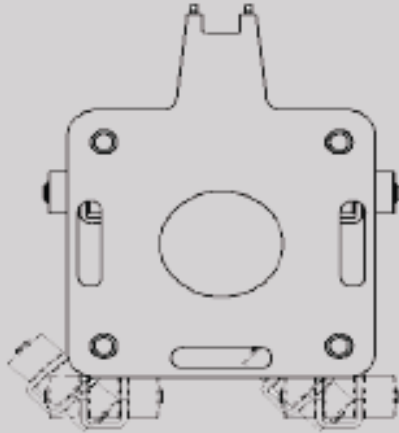

360 DEGREE ROTATION



ALIGNMENT BAR

Combine dollies into pairs using an adjustable alignment bar.



CONFIGURATIONS

Our dollies can be configured in a number of ways including attaching them to the Powerattack or using them in conjunction with our TK-EVO or Trakspporter.

Images are for representation purposes only. Actual product may differ.

TOE JACKS

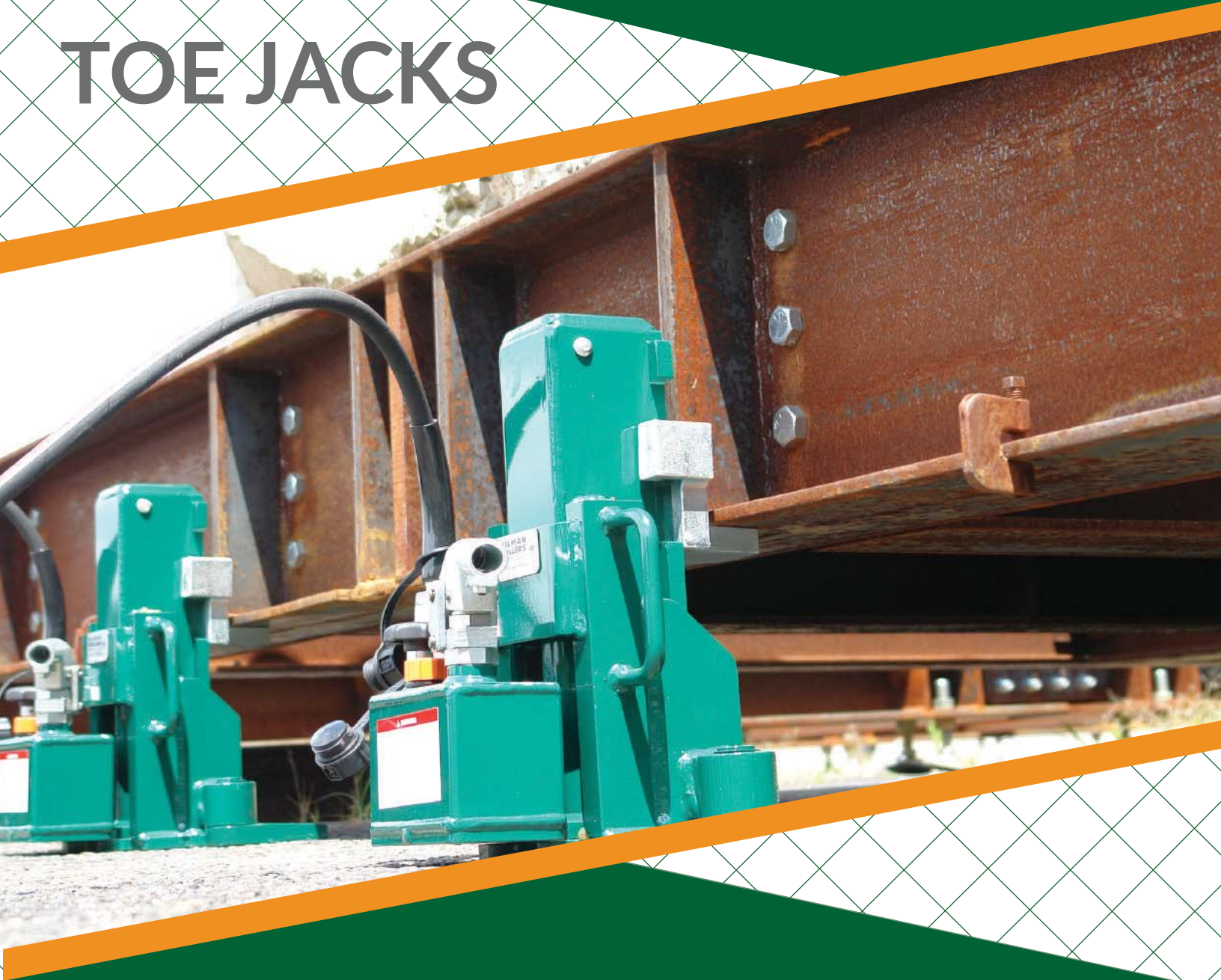

TOE JACKS

Hilman Toe Jacks allow you to get under and lift equipment. Since there are lifting points on both the toe and the top of the jack these are the perfect complement to our chain action rollers and dollies..

5 & 10 TON



10 & 25 DELUXE



20 & 50 TON KITS



LOW GROUND CLEARANCE

-Our Toe Jacks can lift equipment with just over 1" of ground clearance (1.06" to be exact).

HIGH QUALITY LIFTING TOE

-Hilman Deluxe Jacks feature a high quality lifting toe that can be adjusted to several heights to accommodate different lift points.

HYDRAULIC PUMP

- our quality toe jacks kits include hydraulic pumps and have everything you need to lift equipment safely and efficiently

**EASY LIFTING!
USE MANUALLY OR CONNECT TO PUMP!**

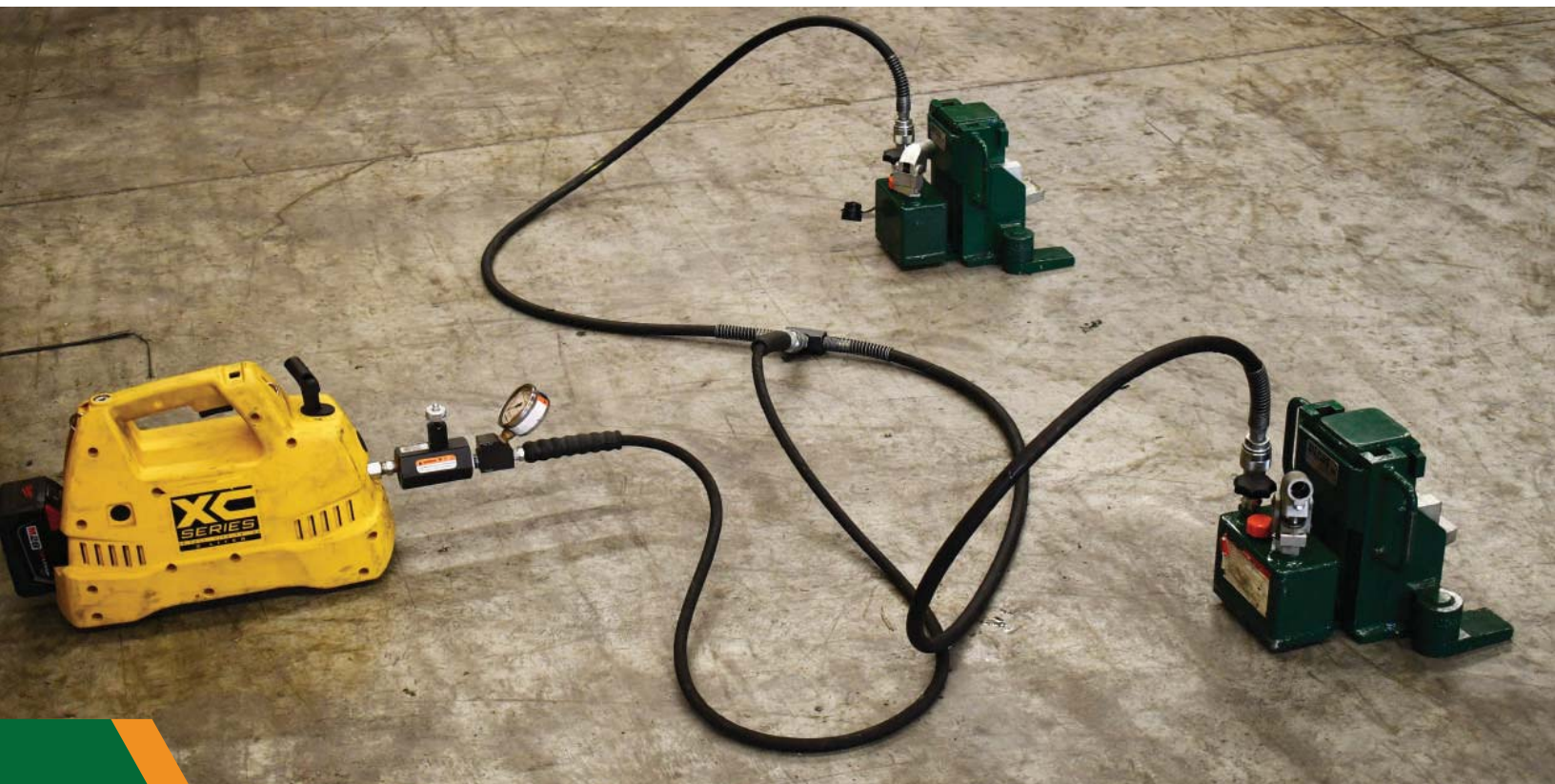

TOE JACKS

LOW CLEARANCE

Our Toe Jacks can lift equipment with just over 1" of ground clearance (1.06" to be exact).

MOVE EASILY

Our 5 & 10 models can operate both vertically and horizontally. Since the base, toe and pump swivel independently of each other, you can fit the jack in confined spaces.

Our Toe Jacks comply with ASME B30.1 standards.



TOE JACKS

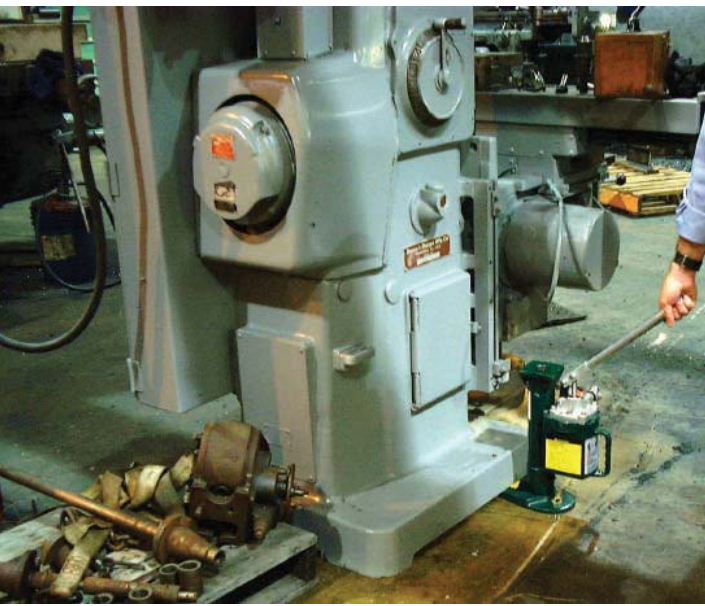

MODEL	CAPACITY	MAXIMUM LIFTING HEIGHT		PICKING UP POSITION HEIGHT		TOE DEPTH (D)	HANDLE LENGTH (H)	FORCE ON LEVER AT MAXIMUM LOAD	WEIGHT
		At Base (A)	At Top (S)	At Base (B)	At Top (T)				
		inches (mm)	inches (mm)	inches (mm)	inches (mm)	inches (mm)	inches (mm)	lb. (N)	lb. (kg)
HTJ5	5 TON	8 (206)	22.5 (574)	1 (25)	14.5 (368)	2.0 (55)	17.75 (451)	85.5 (380)	54 (24.5)
HTJ10	10 TON	9 (233)	25.5 (646)	1 (25)	16.25 (413)	2.0 (55)	17.75 (451)	90.0 (400)	76 (34.5)

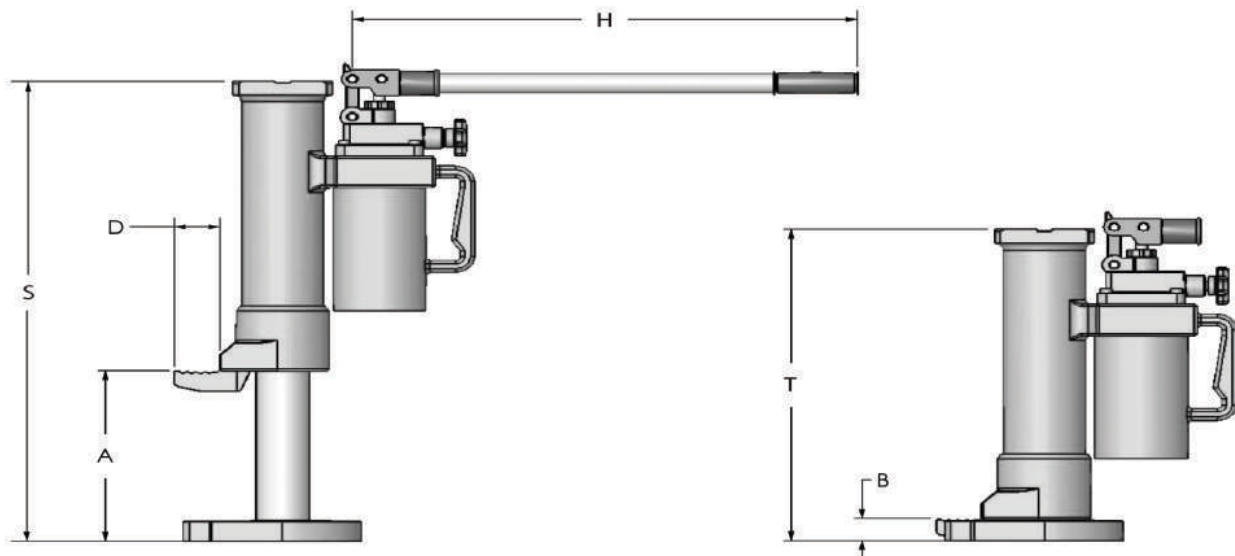

DELUXE JACKS

HIGH QUALITY LIFTING TOE

Hilman Deluxe Jacks feature a high quality lifting toe that can be adjusted to several heights to accommodate different lift points. Strong lift legs and a release valve combine to make stable lifting and smooth lowering of heavy objects.

HYDRAULIC PUMP

Deluxe Jacks come with an external hose coupler that allows the user to attach an external hand or electric hydraulic pump for easy and safe positioning.

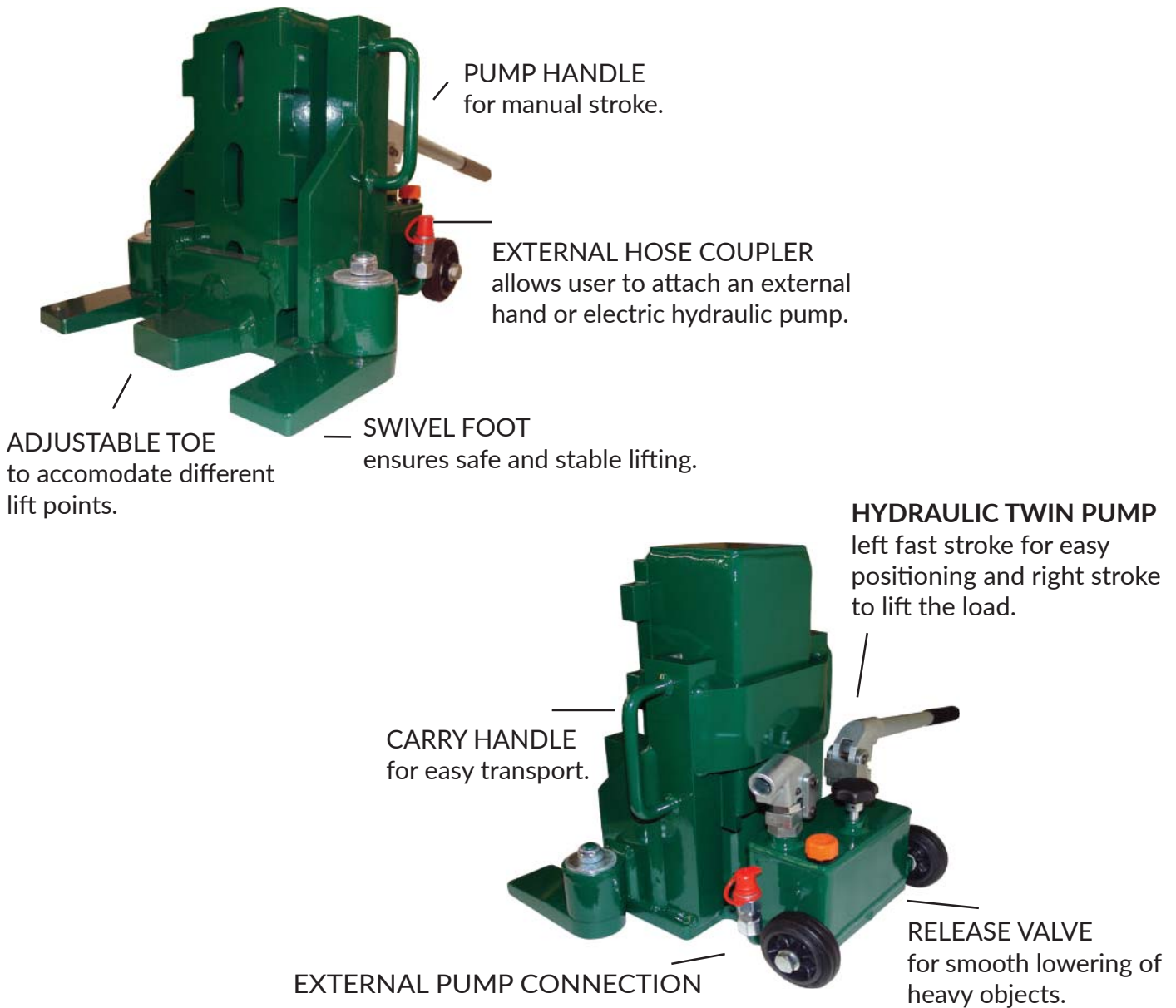

DELUXE

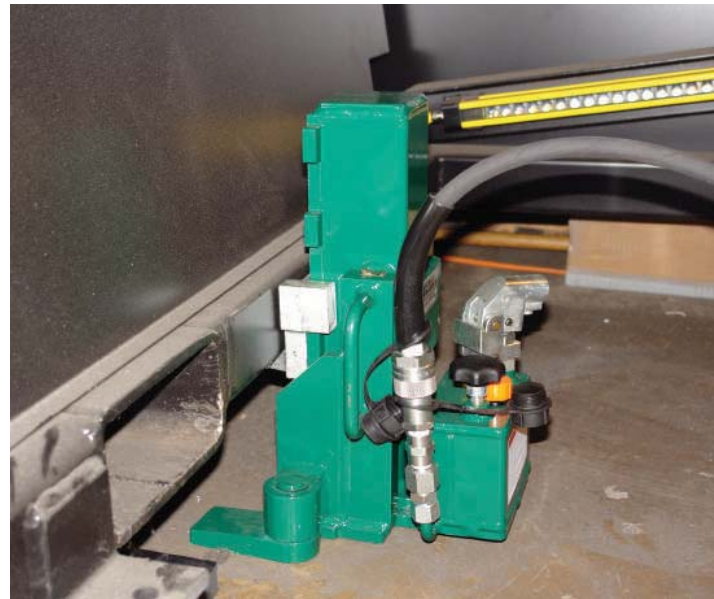

MODEL	CAPACITY	CLAW HEIGHT	ADJUSTABILITY	STROKE	LENGTH (L)	WIDTH (W)	HEIGHT (H)	WEIGHT
		inches (mm)	inches (mm)	inches (mm)	inches (mm)	inches (mm)	inches (mm)	lb. (kg)
HTJ-10D	10 TON	0.79" (20)	3 x 3.19" (3 x 81)	5.5" (140)	10.67 (271)	10.9 (277)	9.8 (250)	62 (28)
HTJ-25D	25 TON	1.18" (30)	3 x 3.94" (3 x 100)	5.5" (140)	15.28 (388)	15.24 (387)	13.0 (330)	159 (72)

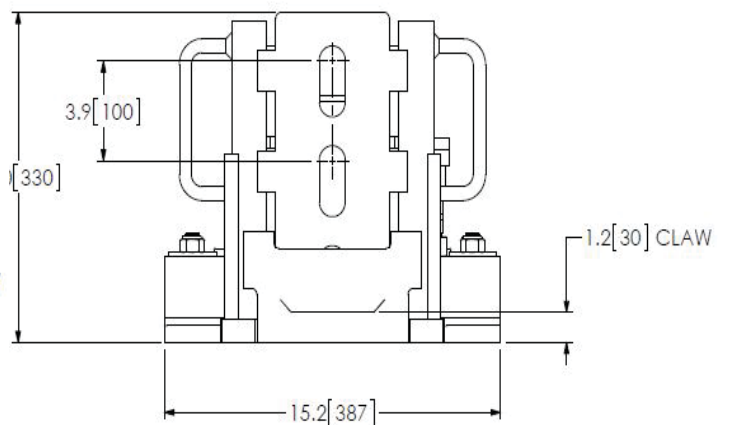
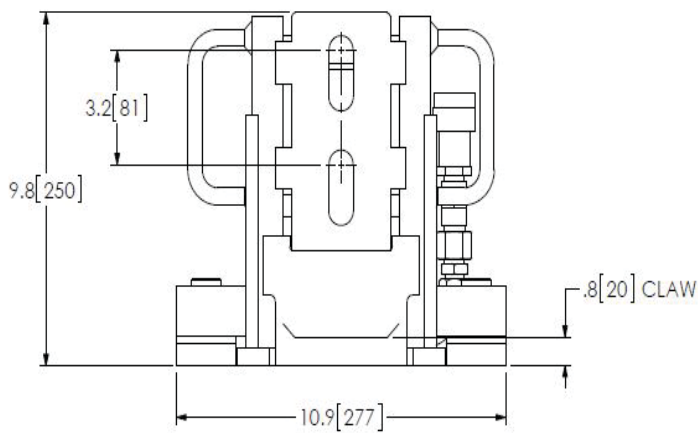

KITS

Everything you need to lift your load with minimal effort. This complete kit features battery powered hydraulic pump, optional manual operation of jacks, adjustable toe, stabilizing feet, release valve for smooth lowering. System comes complete with two 10 ton deluxe hydraulic jacks (manual or automatic operation), portable hydraulic battery powered pump and hydraulic hose assembly with 10' of hose for each jack. Available in 20 & 50 tons. Custom hose length also available.

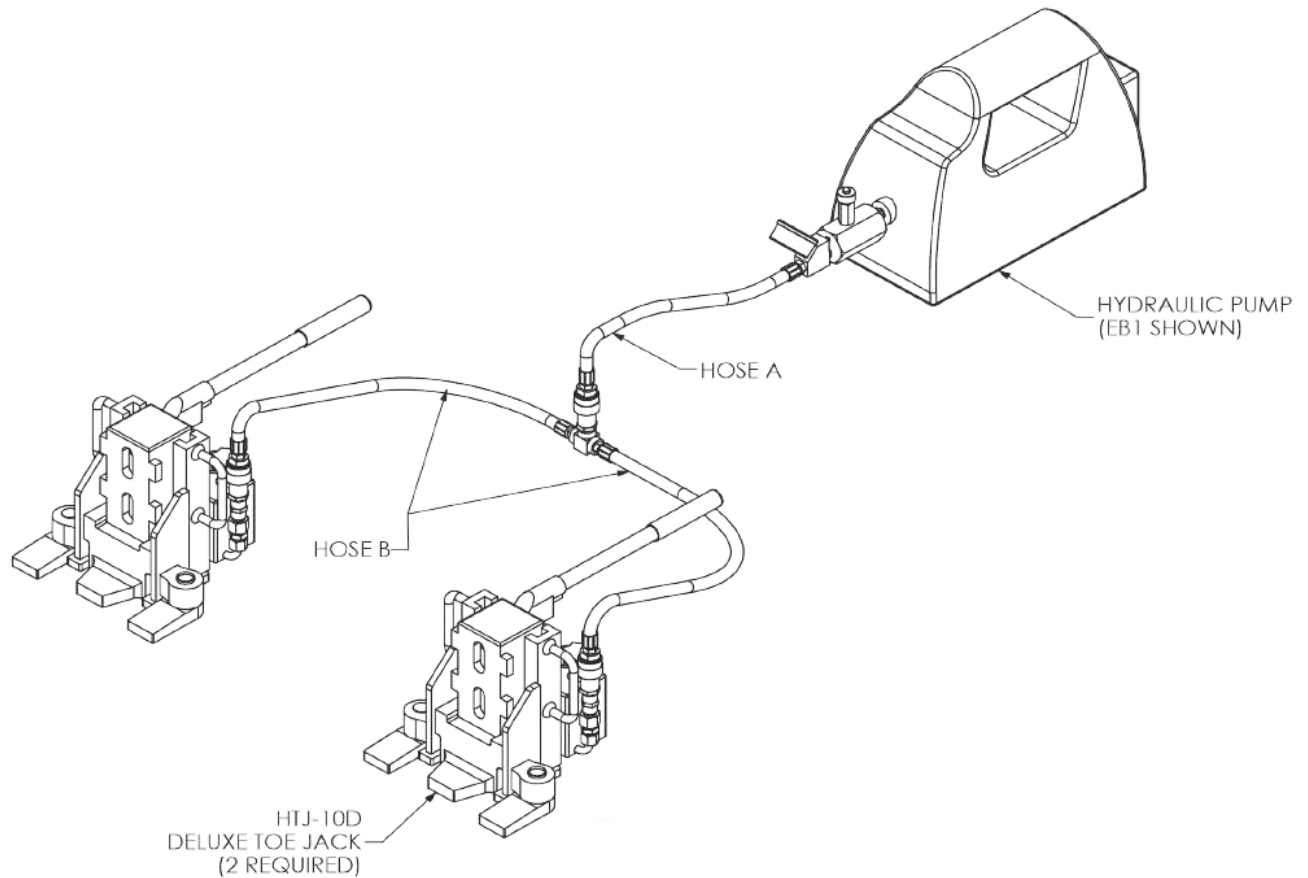

POWERATTACK



POWERATTACK

The PowerAttack is an innovative way to move loads on skates or trolleys up to 30 tons instead of forklifts!

Reliable, Powerful, Easy to Maneuver!

PA25C



Corded-25 Ton Capacity

Powered by an electric cable either with 110V or 230V (PA-25C-230V) drive motor

PA30CC



Battery Powered-30 Ton Capacity

Powered by a 24V synchronous motor with 1kw output, generating 800Nm to drive-wheels

APPLIED MECHANICS

The PowerAttack uses lever and traction to move heavy loads while it is attached to a steerable skate such as the Hilman Tri-Glide with an adaptor. Rear dollies are used for good grip. The handle extends to provide ample leverage giving traction to the powered wheels. The PowerAttack can push or pull up to 30 tons.

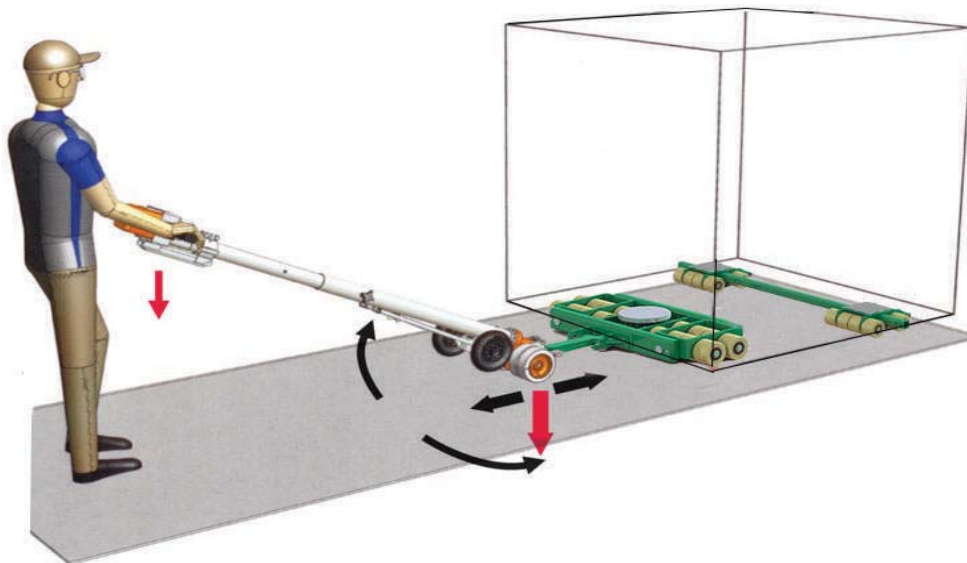

*Images are for representation purposes only. Actual product configuration and support points will differ based on the load.

FEATURES



CLEAN ROOM MOVING

The Battery PowerAttack is a great option for clean room moving or in spaces where emissions is an issue. The soft polyurethane wheels are non-marking and prevent damage to floors.

CUSTOM ATTACHMENTS

The PowerAttack can be used in combination with other Hilman items such as the Tri-Glide. Custom attachments are also available if needed for a specific application.



ADVANTAGES

Each Powerattack comes with an adjustable load toe, an L Adaptor and an adaptor to connect to a front skate. The battery version also includes 2 batteries and charge unit.



Hilman Part #	PA-25C	PA-25C-230V	PA-30CC
Total Capacity	25 tons	25 tons	30 tons
Telescopic Length	65" (1650 mm) - 84" (2150 mm)	65" (1650 mm) - 84" (2150 mm)	65" (1650 mm) - 84" (2150 mm)
Width	15" (380 mm)	15" (380 mm)	15" (380 mm)
Weight	110 lbs (50 kg)	110 lbs (50 kg)	165 lbs (75 kg)

*Loads can be moved up to 30 tons depending on floor surface, types of skates, etc.

UNIVERSAL MACHINERY MOVING KITS

This versatile and easy to use 3 point moving system is designed to meet the majority of your load moving requirements. The kit includes everything you need to move loads easily, effectively and safely.

- Jacking package allows easy lifting of load
- Three-point machine skates provide a stable rolling platform
- Powered load mover makes it easy to move your load into its new position with the push of a button
- Poly wheels offer durability and floor protection



Essential Package

Great Value for Efficient Load Moving!

Includes:

- (1) Corded Power Load Mover
- (1) 3 Point Moving Dolly
- (2) Rear Dollies with Adjustable Spreader Bar
- (2) 10 Ton Manual Toe Jacks

Deluxe Package

Cordless, Easy to Use!

Includes:

- (1) Battery Powered Load Mover
- (2) Batteries
- (1) Charger
- (1) 3 Point Moving Dolly
- (2) Rear Dollies with Adjustable Spreader Bar
- (2) 10 Ton Hydraulic Jacks
- (2) 10 ft Hoses
- (1) Battery Powered Hydraulic Pump



TK-EVO



TK-EVO

Move heavy loads without cords and hazardous exhaust fumes! It is great for use on special flooring including clean rooms, healthcare facilities, microchip and manufacturing plants and more!



The TK-EVO has a low profile height of just 6.4" (163mm) without pad and compact size of 41" (1041mm) x 36" (914mm) with the battery attached. This allows it to fit into tighter spaces and store easily.

POWERED 3-POINT MOVING

The TK-EVO can be used in a 3 point configuration with a pair of rear dollies for easy and safe moving. The TK-EVO can also be used in combination with our other products such as omni-skates which allow for 360 degree rotation.

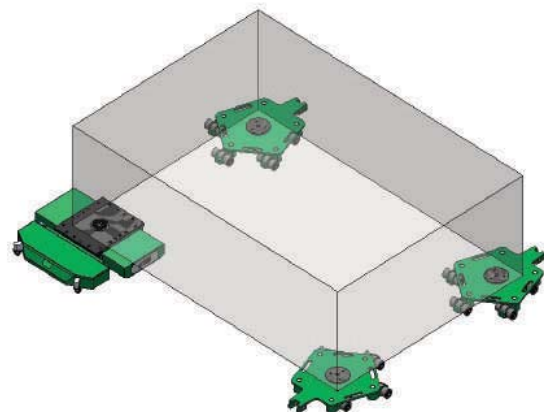
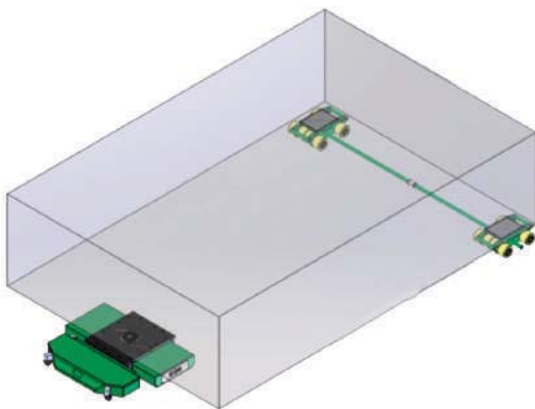

*Images are for representation purposes only. Actual product configuration and support points will differ based on the load.

FEATURES

Typical battery life under working conditions is up to 2 hours. Charge time per battery is up to 3 hours with standard 110V single phase outlet.

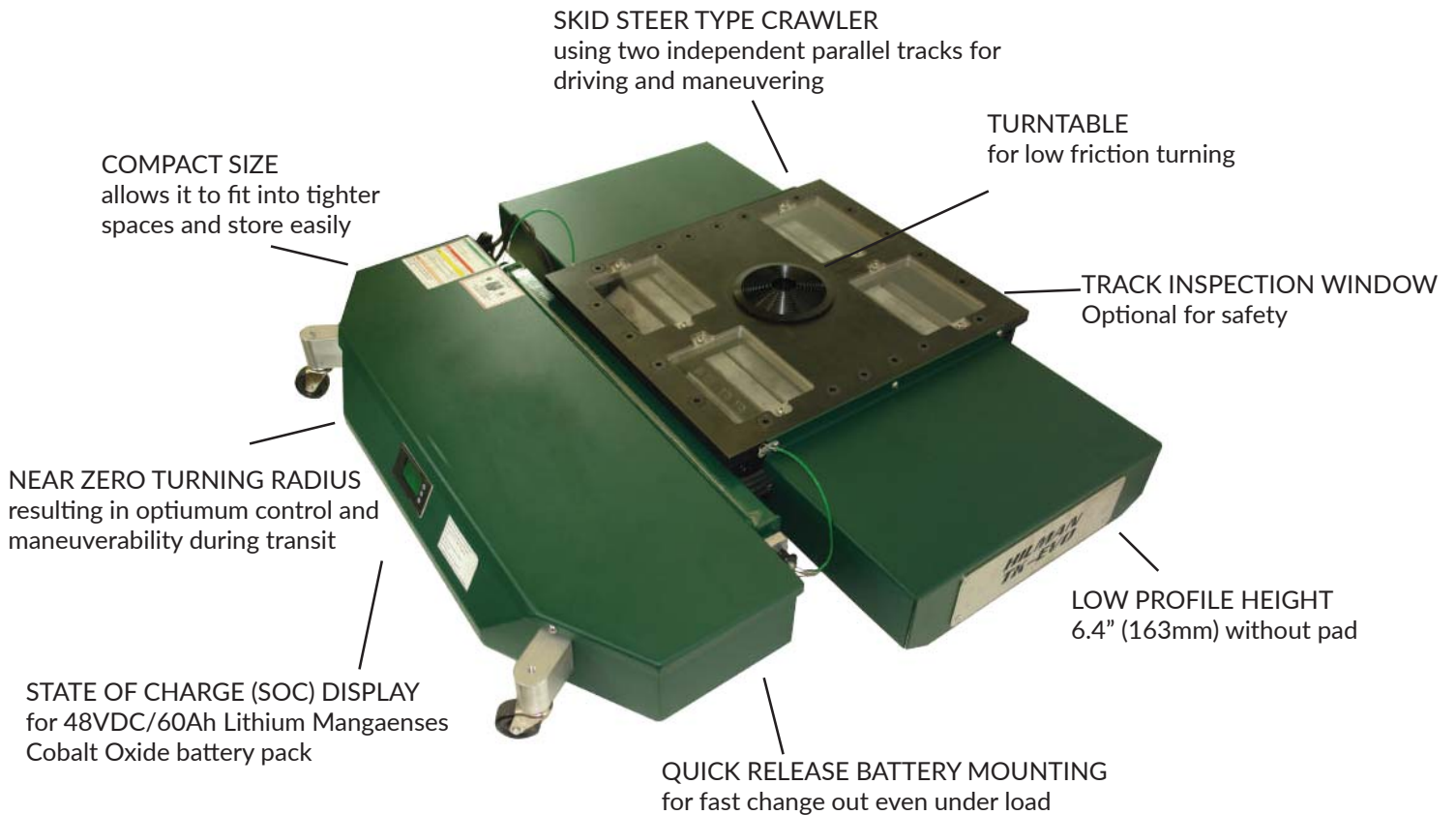

Dimensions	
Length	41" (1041mm)
Width	36" (914mm)
Height	6.4" (163mm) without pad
Capacity*	
Crawler Only	20 tonne (44,100 lb)
Trailer Only	20 tonne (44,100 lb)
Combined Load	40 tonne (88,200 lb)

*Based on flat level riding surface

BENEFITS



NO CORDS. NO EMISSIONS

- No cords eliminate tripping hazards for crew members
- No hazardous exhaust fumes from a IC engine to limit areas for operation
- Quiet operation eliminates the need for ear protection while improving crew communication

PERFORMANCE

- 2 Speed settings with proportional control forward and reverse
 - o High Speed: 12 fpm
 - o Low Speed 8 fpm
- Near zero crawler turning radius
- 48VDC/60Ah with State of Charge (SOC) display
 - o Expected Run Time: > 120 minutes
 - o Recharge Time: < 3 hours with standard 110V single phase outlet



CUSTOM SOLUTION

The TK-EVO can be customized to meet the needs of a specific project. Inspection windows can be added for safety. It can also be combined with other product to make a complete custom moving solution.

PACKAGES

The TK-EVO is offered in a basic package that includes (1) TK-40E with battery and charger and more!



BASIC PACKAGE

Includes:

- (1) TK-EVO Crawler with Battery
- (1) Remote Control
- (1) Spare 48VDC/60Ah Battery
- (1) Battery Charger
- (2) 10 Ton Capacity Dollies
- (1) 8 ft Alignment Bar
- (4) Preload Pads

Training is also included with this package (8 hours max and includes no more than 4 groups-max 8 people per group). For more information please contact us.

CUSTOM OPTIONS

Custom options are available for your specific application including track inspection windows, attachments, turtlebacks and turntables, and rear dolly modifications.

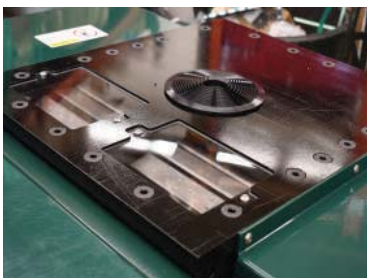

TRAKSPORTER



TRAKSPORTER

Hilman Trakporter is a remote controlled self-propelled crawler system designed to move heavy machinery or other heavy objects safely, easily and efficiently.

The Trakporter consists of two essential parts, the Crawler and the Power Unit.

CRAWLER



A remote controlled hydraulic steering and drive mechanism that is used to direct the movement of whatever is being moved.

POWER UNIT



Provides power to the Crawler through a 23hp LPG powered Kubota engine that can also be custom designed to run on a 25hp electric motor.

POWERED 3-POINT MOVING SYSTEM

The Hilman Trakporter integrates a three point moving system where the front steerable unit is fully powered and operated by remote control allowing the operator to monitor the various contact points while moving resulting in more control. It is used in conjunction with a pair of unpowered rear dollies that allow the tracks to follow the contour of the concrete and help distribute the load evenly.

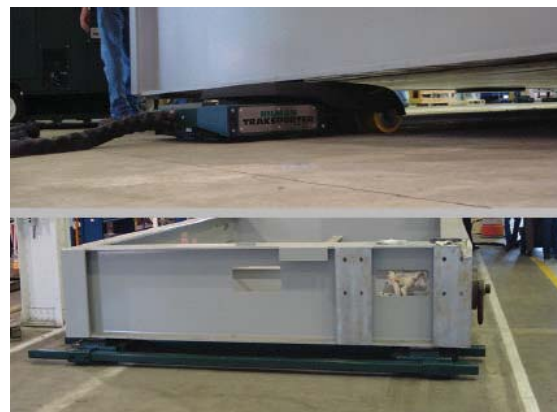

PACKAGES

The Trakporter comes in a variety of packages that provide you with all the tools needed for an easy move. Additional options such as trailers, custom jacking systems and complete tool carts are also available.



All Basic & Deluxe packages include (1) 130-BP Trakporter with 30 Ton Capacity Remote-Controlled Crawler.

BASIC

TK50 BASIC (50 TON)	TK75 BASIC (75 TON)	TK100 BASIC (100 TON)
Includes:	Includes:	Includes:
(2) 12 Ton Capacity Dollies	(4) 12 Ton Capacity Dollies	(4) 12 Ton Capacity Dollies
(1) 8 ft. Roller Alignment Bar	(1) 8 ft. Roller Alignment Bar	(1) 8 ft. Roller Alignment Bar
(4) Rubber Pads	(4) Rubber Pads	(4) Rubber Pads
	(4) Plywood Pads	(4) Plywood Pads
	(2) 1.25 inch Spreader Plate	(2) 1.25 inch Spreader Plate
		(1) Turtleback

DELUXE

TK75 DELUXE (75 TON)	TK100 DELUXE (100 TON)
Includes:	Includes:
(1) Tool Cart	(1) Tool Cart
(4) 12 Ton Capacity Dollies	(4) 12 Ton Capacity Dollies
(4) Roller Alignment Bars (4 ft., 6 ft., 8 ft., & 10 ft. long)	(4) Roller Alignment Bars (4 ft., 6 ft., 8 ft., & 10 ft. long)
(2) 1.25 inch Roller Spreader Plates	(2) 1.25 inch Roller Spreader Plates
(4) Rubber Pads	(4) Rubber Pads
(4) Plywood Pads	(4) Plywood Pads
(8) Oak Wedges	(8) Oak Wedges
(4) 10 Ton Toe Jacks	(4) 10 Ton Toe Jacks
(2) Battery Powered Cordless Pumps (w 6 ft. Hose)	(2) Battery Powered Cordless Pumps (w 6 ft. Hose)
(2) 30 Ton Cylinders	(2) 30 Ton Cylinders
(2) 10 foot Splitter Hoses	(2) 10 foot Splitter Hoses
(2) Floor Plates (.1875 inch x 16 inch x 60 inch)	(2) Floor Plates (.1875 inch x 16 inch x 60 inch)
	(1) Turtleback

Training is also included with this package (8 hours max and includes no more than 4 groups-max 8 people per group). For more information please contact us.

MODIFICATIONS

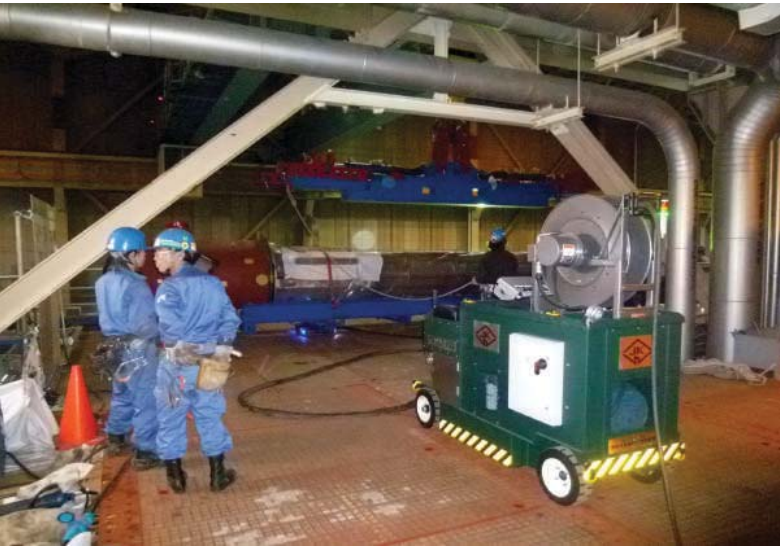

ELECTRIC MOTOR

The Trakporter can be made in an Electric version using a 25hp electric motor for applications where combustible fuels are not allowed.

UPGRADEABLE

Any Hilman Trakporter system is upgradeable to 100 tons moving capacity utilizing our Hilman Turtleback option. It has a direct load capacity of 55 tons (110,000 lbs). It features (5) 6" diameter wheels with continuous shaft that can be easily changed to optional nylon wheels with shaft and a turntable. Rear dollies can also be upgraded to match capacity.



CUSTOM SOLUTION

The Trakporter can be customized into a complete load moving solution including carts, rollers and hydraulics etc.

FEATURES

Trasporter is intended to be operated on level floors, preferably concrete. Trasporter systems can be configured in 50 ton, 75 ton, 100 ton, and 200 ton layouts to handle heavy load moving through challenging haul paths (tight turns, exact final set locations, etc).

POWER UNIT
provides power to the Crawler



ENGINE
runs on a 23hp LPG powered Kubota engine that can also be custom designed to run on a 25hp electric motor

UMBILICAL CORD
30-foot long cord that houses the hydraulic lines to the Crawler

STORAGE
for the crawler

CRAWLER
low profile remote controlled hydraulic steering and drive mechanism

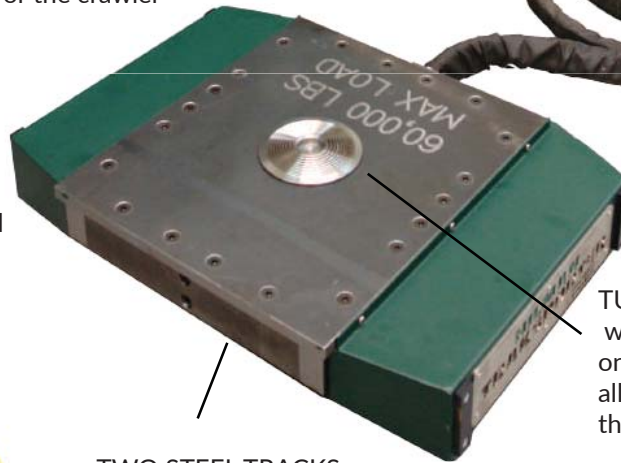

TURNTABLE
with aggressive anti-slip pattern on top and bearings underneath allow the crawler to rotate under the machine being moved

TWO STEEL TRACKS
controlled via joystick on the remote control allow the crawler to push, pull and turn 360 degrees



OPTIONAL TOOL CART
can supply a full complement of accessories such as jacks, pumps, hoses, wedges, pads, cylinders, etc.

REMOTE CONTROL
with bidirectional joystick to control each track pad



BENEFITS

Move heavy objects in tight areas where it is difficult or impossible to use a forklift or other means.



SELF-CONTAINED/SELF-PROPELLED

- No additional equipment is required to move the Trakporter.
- Eliminate the need to push or pull the object with a forklift and reposition to make corners.
- Provide smooth continuous power to navigate corners non-stop and with maximum control.
- Stores easily inside the Power Cart

BETTER USE OF MANPOWER

- Reduce the need to transport heavy forklifts and multiple vehicles to jobsites. To move equipment to site only requires a pick-up truck and a trailer.
- Less effort and faster. No longer the need to bump and push the object with forklifts.
- Quickness of the move with minimal disruption to their operation.



SPECIFICATIONS

Size of Power Unit	Length 65" x Width 30" x Height 44"
Weight	1500 lbs. (operating)
Engine	WG750B Kubota 45 cu in. Displ. 23hp Propane (emissions certified) liquid cooled, 12 volt.
Solid rubber tires	13.5" x 4.5"
Hydraulic steering and drive	
Crawler is stored in its own compartment self loading and unloading.	
Top storage area with 2" rail for tools, blocks, rollers etc.	
Capacity	30 ton directly on crawler turntable
Pulling Capacity	75 ton
Speed	Adjustable 0-25 fpm
Turning Radius	Zero turn
Size of crawler unit	26" L x 31" W x 6.375" H
Weight.	540 lb
Power supply hose	30' long (protected by nylon sleeve)
Track Packs	Solid steel (smooth face)

ENGINEERED SOLUTIONS



A PERFECT FIT

CUSTOMER SPECIFIC ENGINEERING

No matter how complex or time-sensitive your project is, Hilman will develop a solution custom-built for your unique application. Bring us your most challenging requirements and let our experienced team of engineers help solve the issues that are impacting your performance.



CAPABILITIES

Our team is a group of thinkers, innovators and problem solvers that partner with our customers throughout each phase of a project – design, engineering, manufacturing and installation - to ensure quality standards and customer expectations are met or exceeded.

Our customer support system is unparalleled in the industry and we continually strive to make improvements in every department to ensure quality and customer satisfaction.

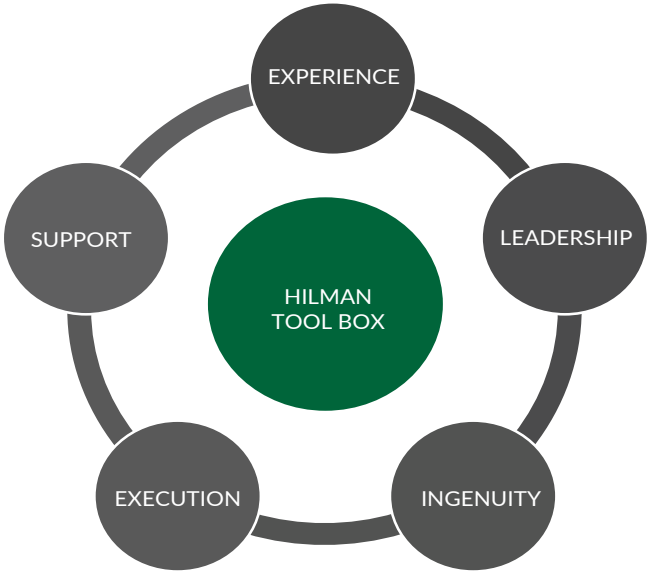

OUR PROCESS

Hilman designs, engineers and fabricates custom solutions for your project needs. Our engineers work closely with you and your team to ensure the optimal moving experience.

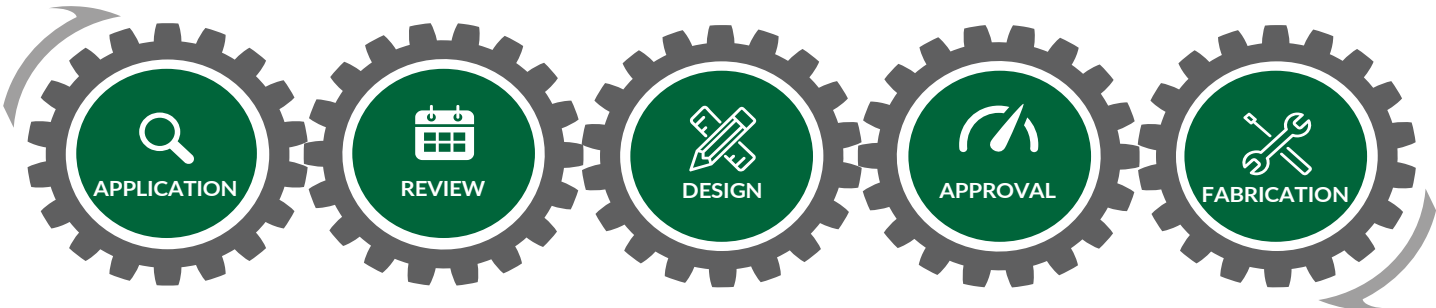

APPLICATIONS

Hilman provides custom engineered solutions to industries around the world.

BRIDGE CONSTRUCTION

- Casting Yard Transfer
- Casting Machines
- Segment launching
- Roll-in entire spans
- Launching trusses
- Traveling formwork
- Segmental bridge forms
- Incremental Bridge Launching



OIL & GAS

- BOP, Xmas Tree Handling
- Cantilever Drill Skidding
- Deck & Jacket Loadout
- Module Installation
- Land Rig Skidding
- Lift and Roll Systems



OEM



- Quick Die Change Carts
- Bridge Arms - Cart to Press
- Storage Racks
- Just in Time Automation Systems
- Prestaging carts
- Transfer Systems
- Coil Handling Equipment
- Die Lift Rollers
- Die Separators

POWER/NUCLEAR



- Transfer Cradles and Carts
- Transformer Installation
- Turntable Systems
- Decommissioned Vessels
- Thermal Expansion
- Switchgear
- Steam Generators
- Wind Power Machines
- Spent Fuel Conveying
- Hazardous Waste Casks

BUILDINGS & STRUCTURES

- Essential Rigger and Millwright equipment
- Advancing Scaffolding
- Building Moves
- Large Monuments & Historical Structures
- Sliding Roofs
- Rolling Grandstands
- Container Cranes
- Draglines
- Specialized Gantry Cranes



INDUSTRIAL MACHINERY



- Heavy, Bulky Machinery
- Machine Servicing & Installation
- Assembly & Transfer Carts
- Heavy Materials Handling
- Displays
- Heavy Product Demonstrations
- Heavy Conveying

AEROSPACE/RESEARCH



- Radiation Shield Doors
- Magnets
- Reactors
- Submarines
- Wind Tunnels
- Space Rocket Transfer
- Cryostats
- Detectors & Modules
- Launch Towers

SHIP/MARINE

- Drydock & Ship Transfer
- Ship and Barge Launch
- Yard Transfer
- Pipe & Cable Laying
- Ship Transfer Cradles



MOTORIZED ROLLER

The Hilman Motorized Roller is a low-profile, high-capacity custom solution for permanent, repetitive movement of heavy objects.



LOW PROFILE, HIGH CAPACITY

The motorized chain roller assembly is compact, self-sufficient, has a high load carrying capacity. It reduces the time and machinery necessary to transport heavy loads.

SELF-PROPELLED

A motorized chain roller includes a frame, a special endless roller chain assembly and two powered sprockets. Hydraulic or electric motors spin the sprockets pulling the chain resulting in smooth forward and back movement.

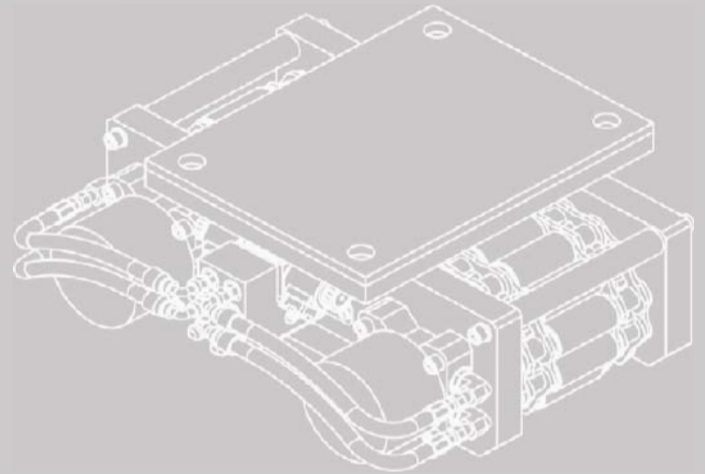

FULL SYSTEMS

Hilman can design, fabricate and supply complete load moving systems with steel track, power unit and Motorized Rollers for your next move. Some custom options include load, speed and the option to have an electric or hydraulic motor.

SWIVEL RAM ROLLER

Hilman Swivel Ram Rollers are a safe, efficient, cost-effective custom rolling system for moving heavy loads requiring frequent direction changes and precise load positioning.



360° ROTATION

Equipped with dual roller chains and an integrated lifting cylinder in a single moving unit, Hilman Rollers Swivel Ram Rollers function conventionally, the rollers contact the rolling surface and the load moves easily.

When a change in direction or course adjustment is required, the cylinder simply lifts the load from the rollers, temporarily parking the load. Once parked, the rollers can pivot 360 degrees to allow precise selection of a new direction of travel. Retracting the cylinder lowers the load back onto the rollers and the load is now ready to travel in its new direction.

APPLICATIONS

They can be used in many applications including Die Changes, X-Y Transfers, Track Intersection, Cart Transfers, Modular Moves, Heavy Rigging, Bridge Construction, Tight Areas and more!



ACCU-ROLL

In certain instances, Hilman Swivel Ram Rollers can also be equipped with Hilman Rollers Accu-Roll Guidance Systems for traveling on Rail, I-beam, Flat-bar, or Channel, providing even greater control and flexibility for precision moves. Locking blocks and cylinders with various stroke sizes are also available.

CARTS

Hilman can supply custom steel fabrications for a variety of components to be integrated, or used in conjunction, with our heavy-duty rollers. We have designed and built several heavy-duty carts that utilize our rollers to move heavy equipment and materials.

PRODUCTION, MANUFACTURING, DIE HANDLING

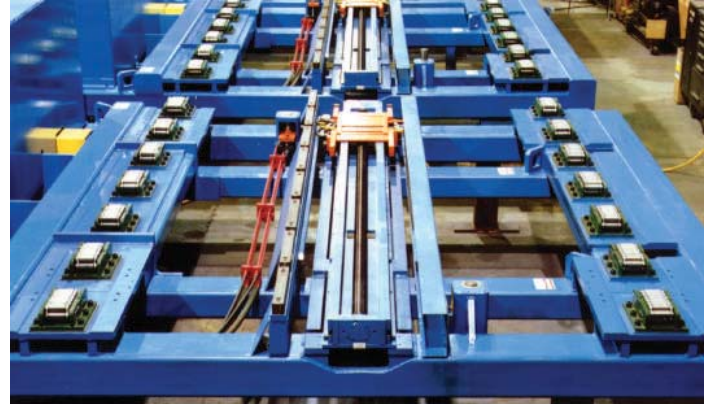

LOW PROFILE TRANSPORTERS



POWERED SYSTEMS



HYDRAULIC INTEGRATION

Hilman can integrate hydraulic cylinders, either as motive force or to lift a load for a specific reason; or both. Motive Force can be applied in any number of ways. Solid chain-drive systems and/or hydraulic push-pull cylinders are just a couple of the solutions that Hilman has supplied with complete control systems for easy user interface.



EXPERIENCE

Hilman designs, engineers and manufactures complete turnkey custom solutions tailor-made to your project needs. Our engineers work closely with our customers on unique projects around the world to supply them with products that integrate seamlessly into their applications for a perfect move!

1000'S OF PROVEN DESIGNS





HILMAN INC.
12 Timber Lane
Marlboro, New Jersey 07746
USA
Phone: +1-732-462-6277
E-mail: sales@hilmanrollers.com
Website: www.hilmanrollers.com

ISO 9001