

# Viking Quick Mount Saddlebag for Triumph Street / Speed Twin 900:



## Parts:

i	Mounting Bracket	x2
ii	Street Twin / Scrambler Bracket	x2
iii	Street Cup Bracket	x2
iv	Roundhead Screw - M8 x 20	x2
v	Round-Head Screw - M8 x 16	x4
vi	Roundhead Screw with Flange - M8 x 16	x4
vii	Spacers	x4

## Note:

- i. The installation shows mounting on one side only, you can follow the same steps for the other side.

## Parts Diagram:

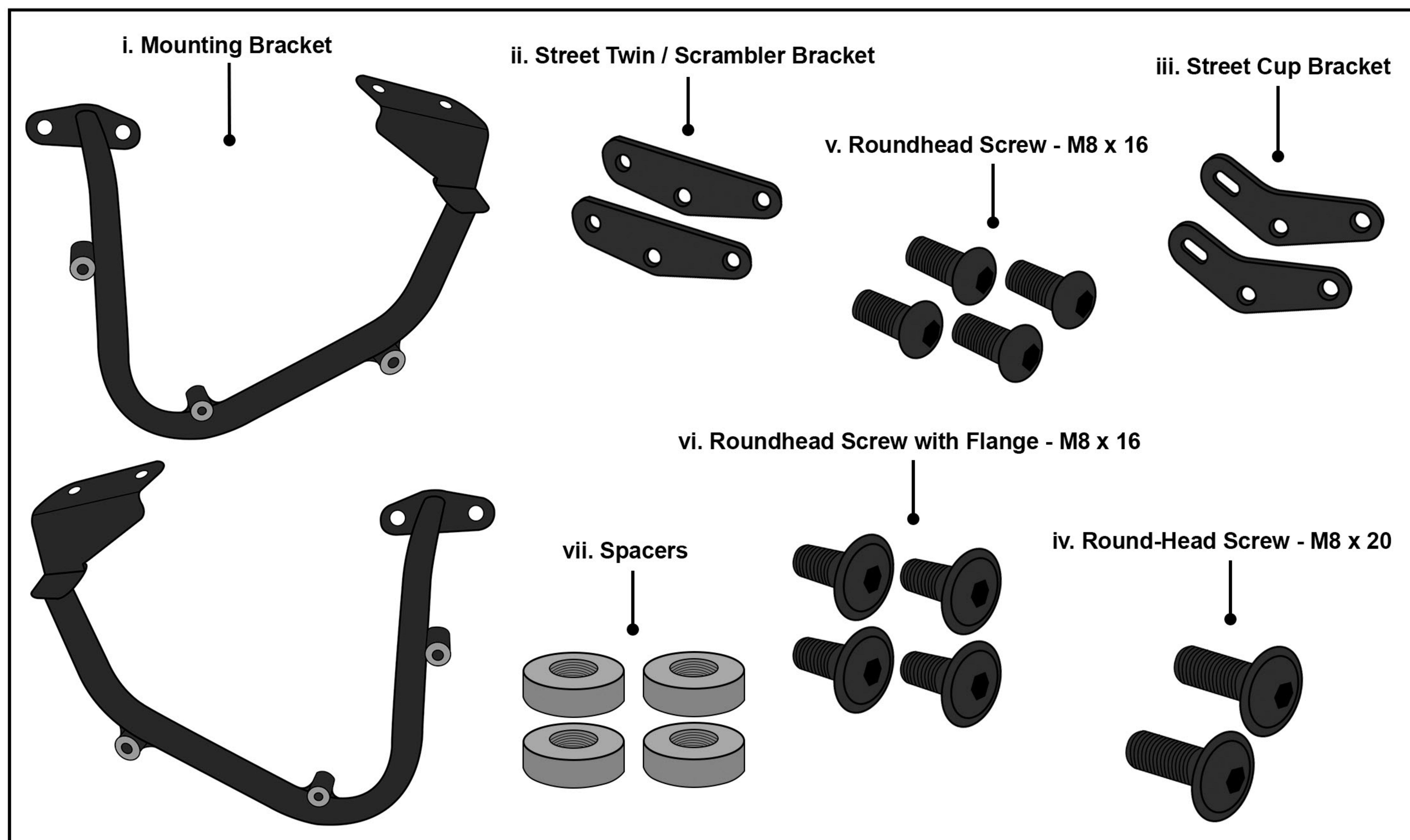

## Installation Instructions:

### Step 1:

**Street Scramble:** Remove the passenger seat and remove the 4 OEM rear screws as shown in figure 1.

**Street Twin / Street Cup:** Remove the passenger seat from you motorcycle.

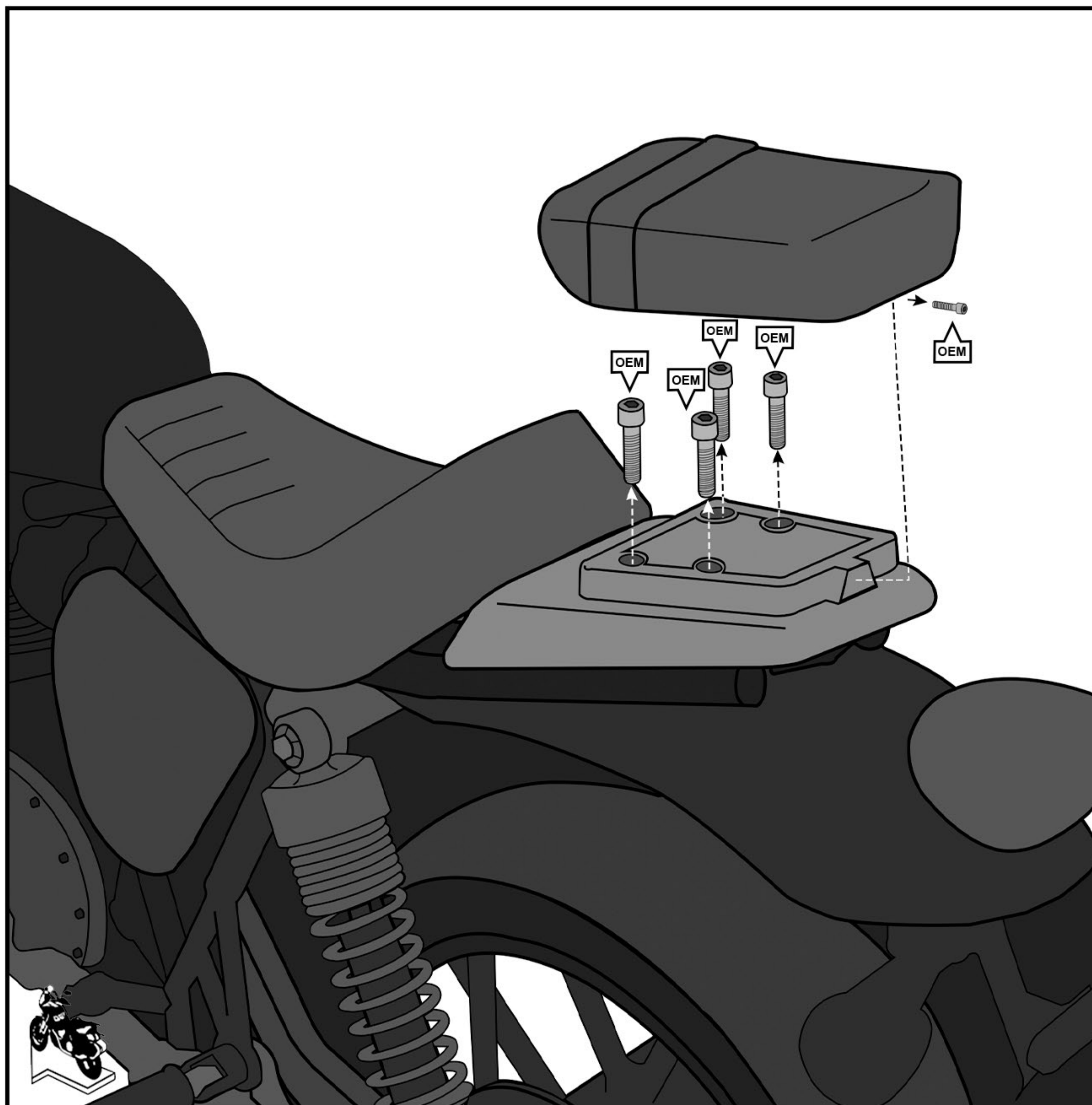

**Fig 1. Removing the Seat**

## Step 2:

Depending on your bike, attach the Street Twin/ Scrambler Bracket (ii) or Street Cup Bracket (iii) behind the shock using the provided roundhead screw (iv). Note that you must only install one of the 2 brackets, based on your bike model.

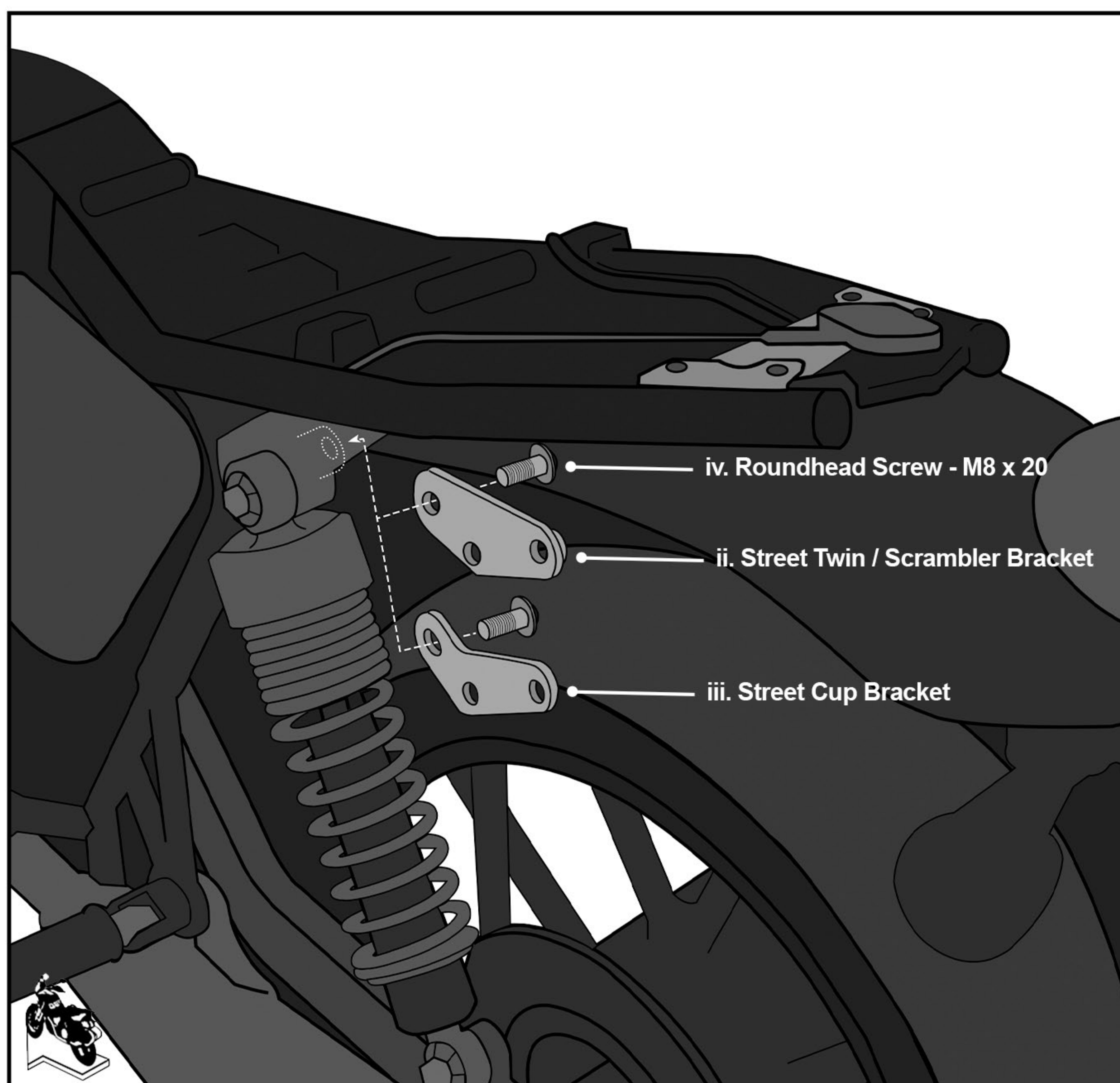

**Figure 2. Installing the Bike-Specific Bracket**

## Step 3:

This step is for Street Twin. Skip to step 4 for Scrambler and Street Cup Models.

Attach the mounting bracket (i) to the bike using the provided screws (v and vi). Note that the mounting bracket attaches to the bike using 2 holes on the frame of the bike and 2 holes in the previously installed bike-specific bracket. See Figure 3.

Use the medium thread locker and tighten to 20 N-m.

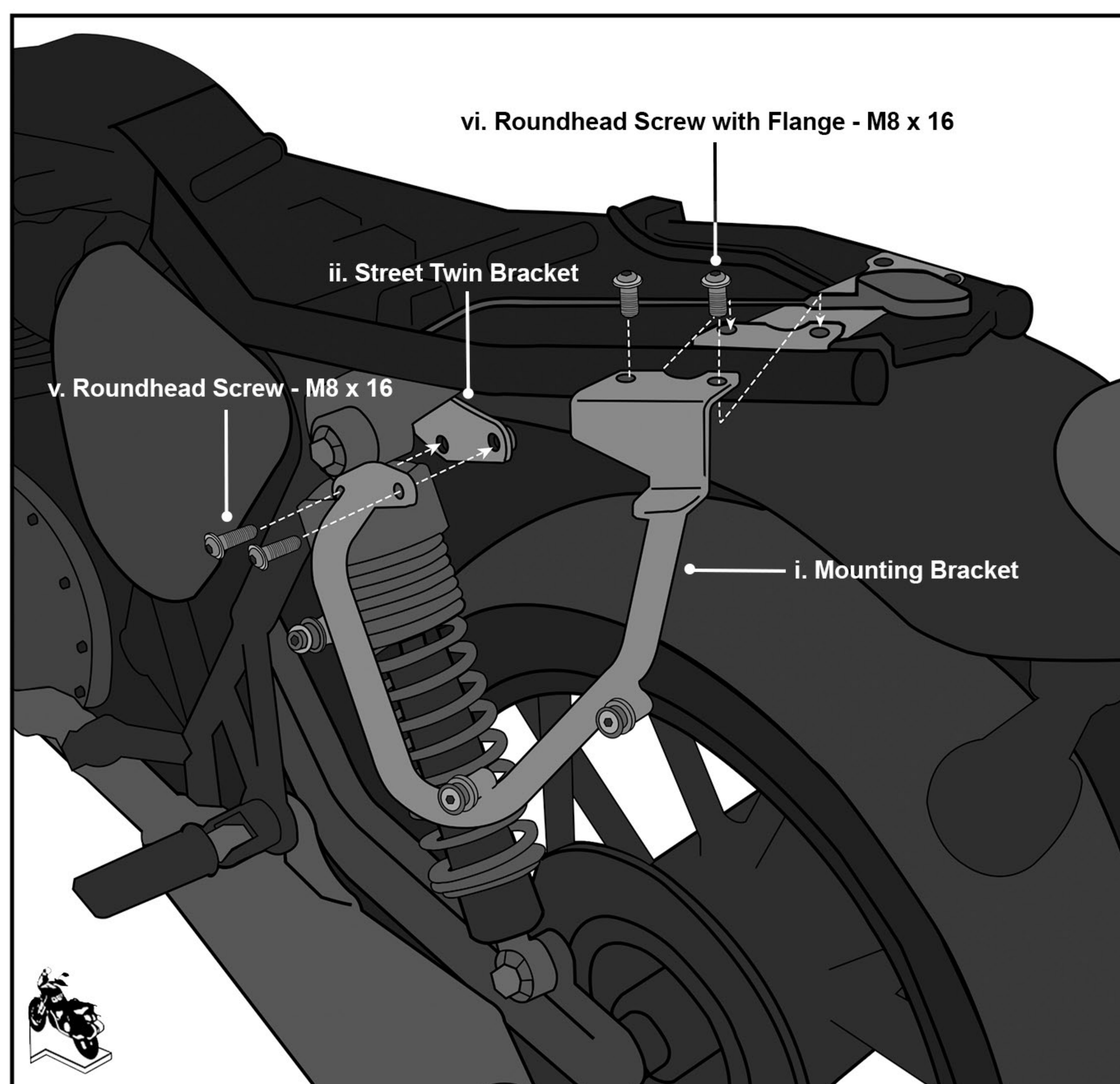

**Figure 3. Installation for Street Twin**

## Step 4:

This step is for Scrambler and Street Cup models only.

Attach the mounting bracket (i) to the bike using the provided screws (v and vi). Note that the mounting bracket attaches to the bike using 2 holes on the frame of the bike and 2 holes in the previously installed bike-specific bracket.

For Scrambler models, use the two provided spacers (vii) on the opposite end to keep the seat level. See Figure 4.

For Street Cup models, use the provided spacers (vii) under the seat locking assembly. See Figure 5.

Use the medium thread locker and tighten to 20 N-m.

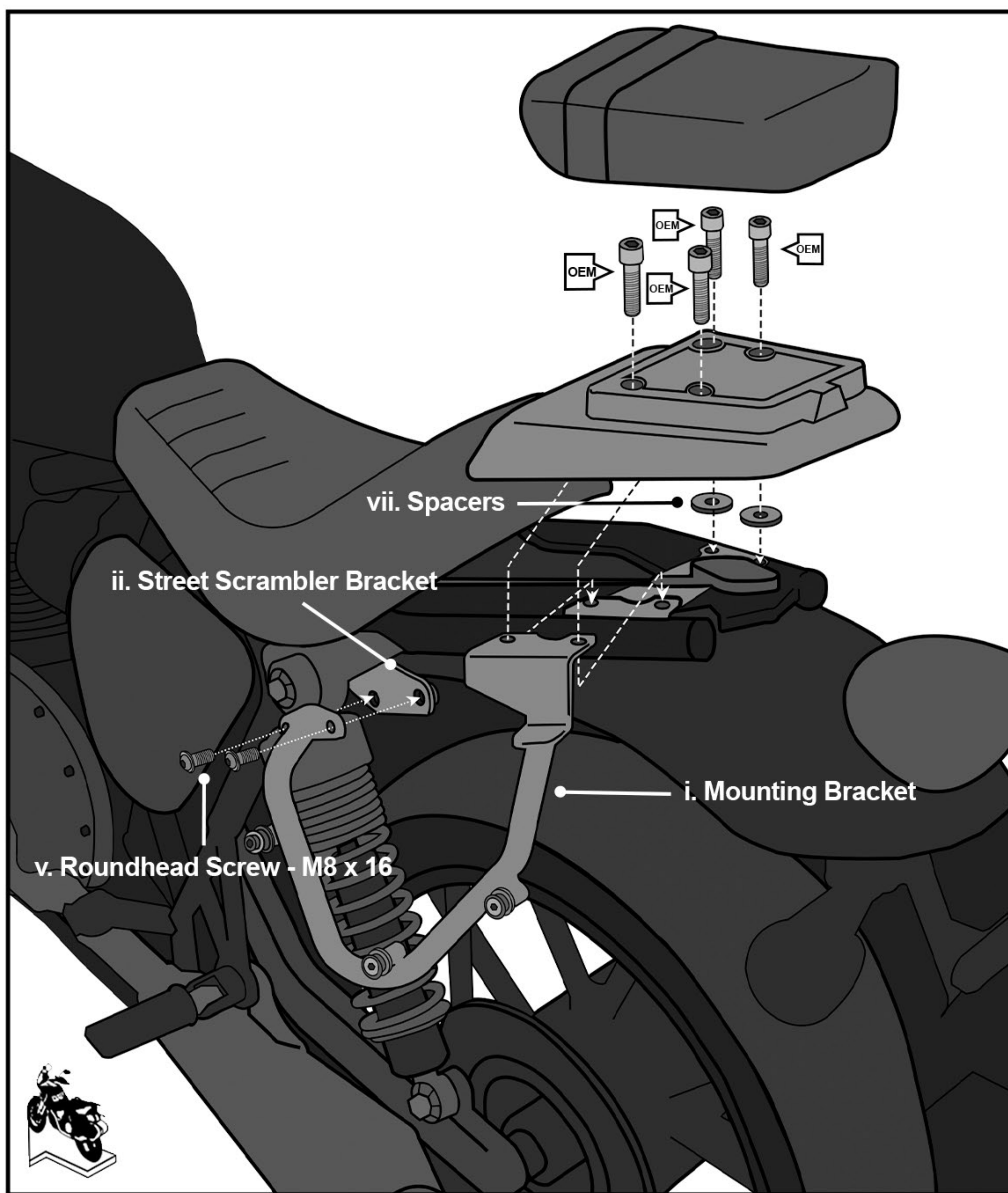

Figure 4. Installation on Scrambler Models

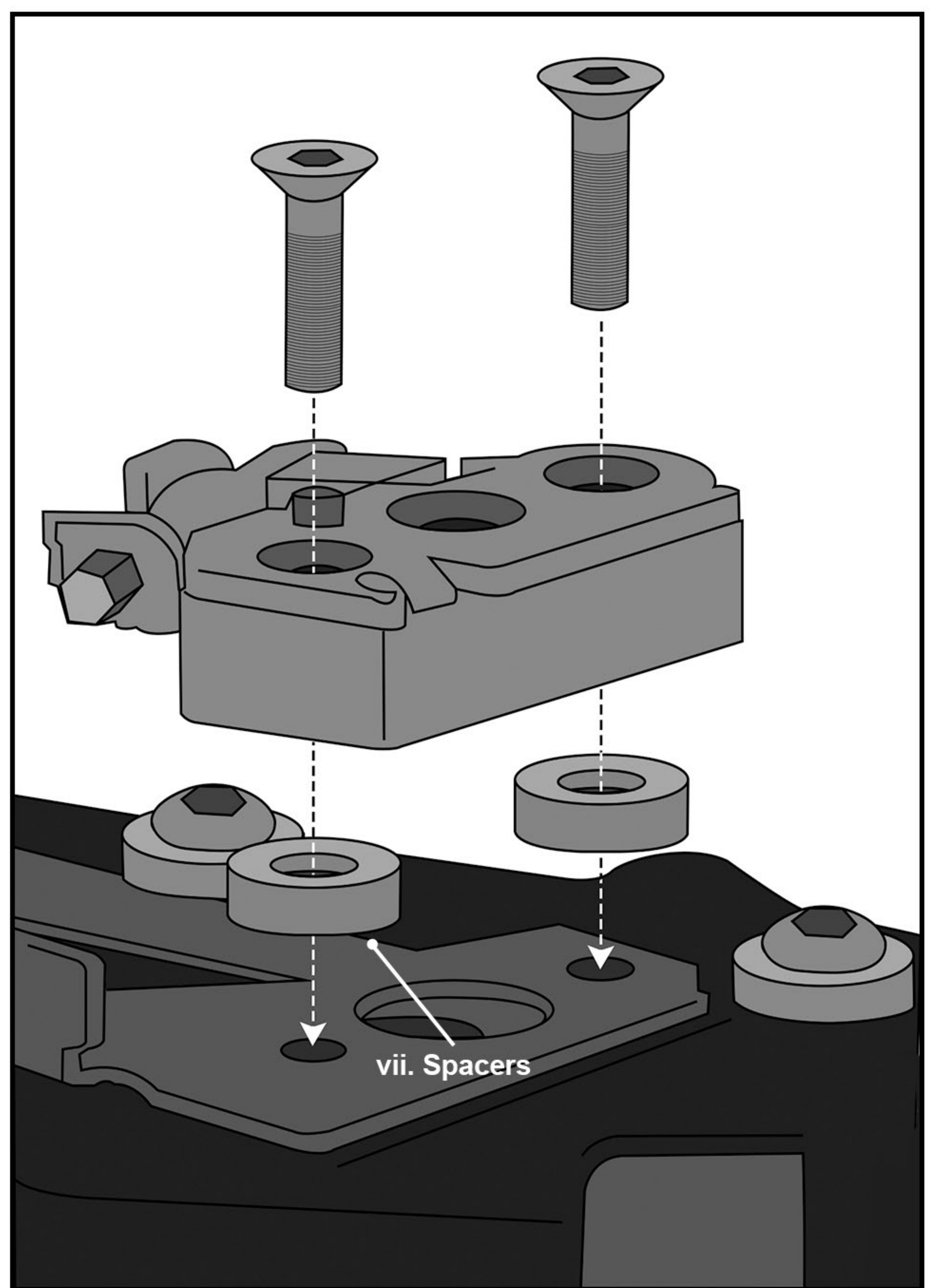

Figure 5. Installation on Street Cup Models

## Step 5:

The back of the bag comes equipped with a quick disconnect bracket.

Attach the bag to the mounting bracket by aligning the holes in the quick disconnect bracket with the 3 docking posts. Push the bag downwards so that the docking posts engage with the grooves in the bracket and the bag locks in. See Figure 6.

Pull the lever to disengage the lock and remove the bag.

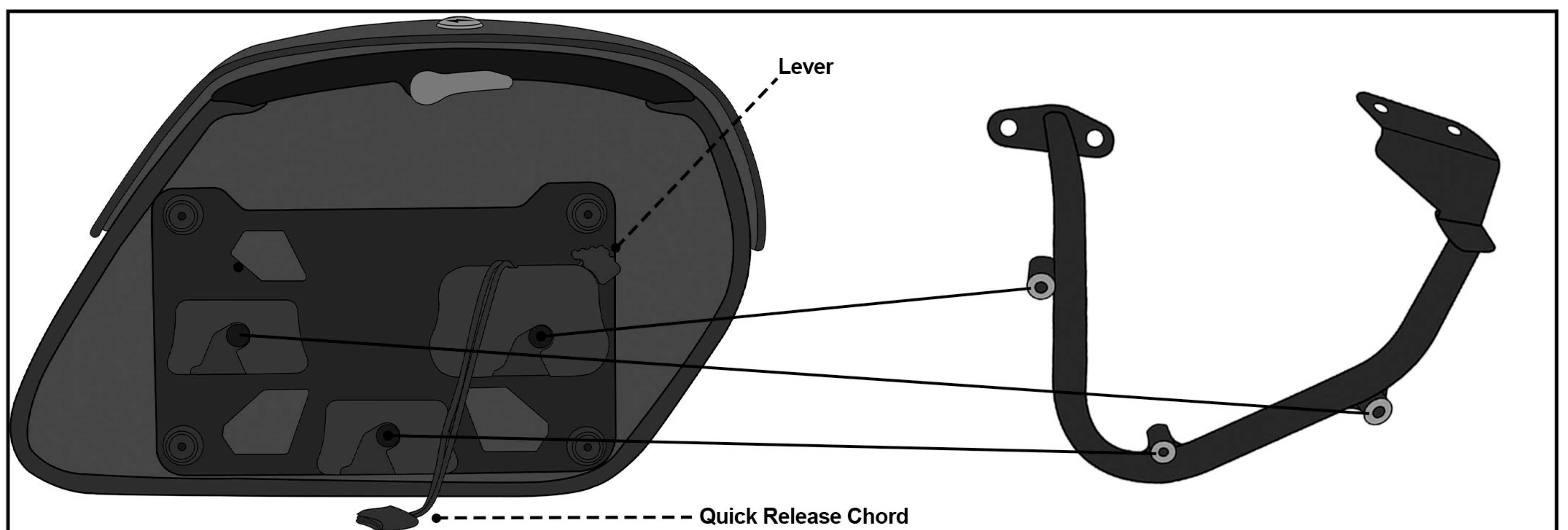
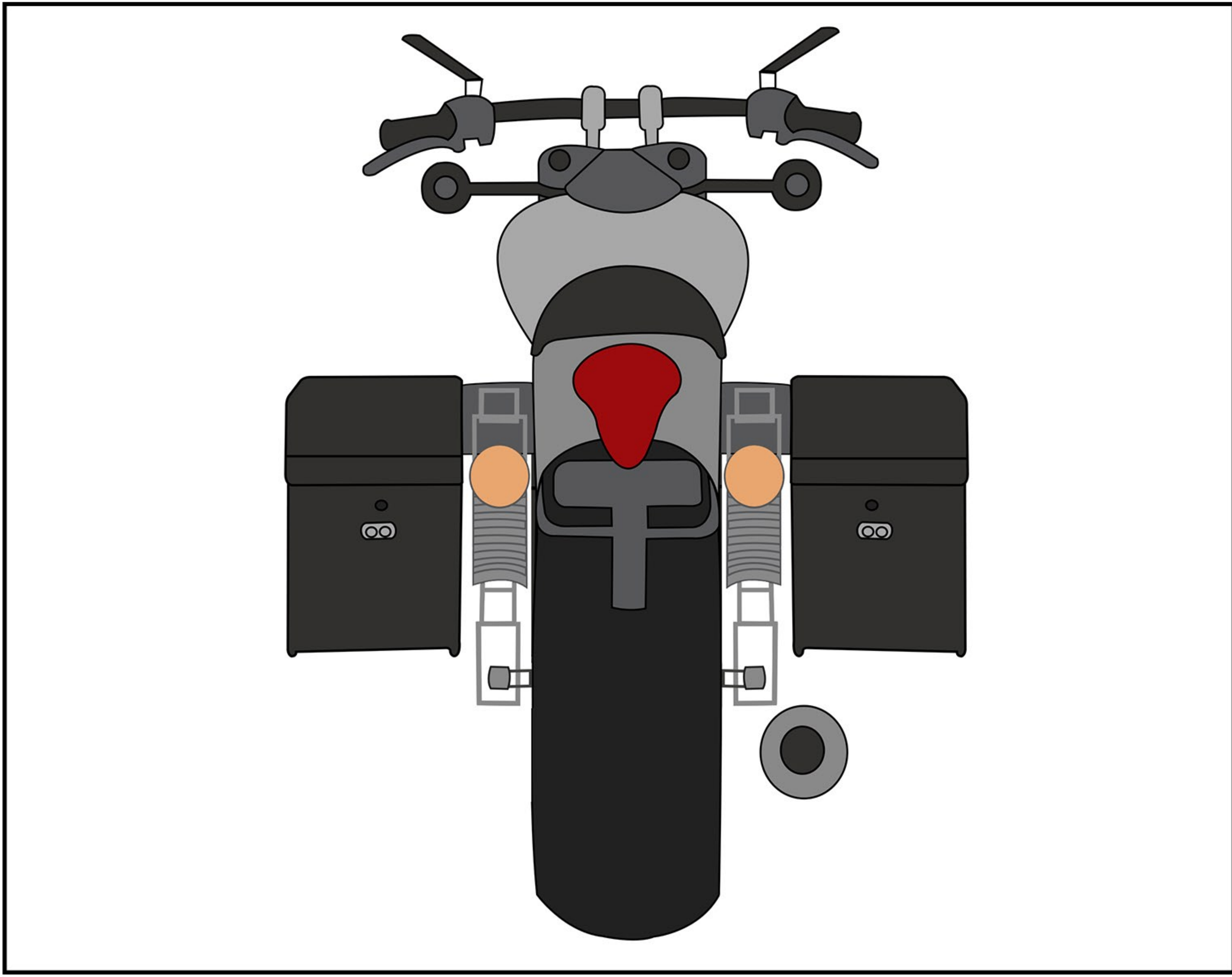

Fig 6. Attaching the Saddlebag



**Fig 3. Both Saddlebags Installed**

**Tip:**

The quick disconnect system is key lockable. Lock / unlock the quick disconnect system from inside the bag to secure your bag against theft.

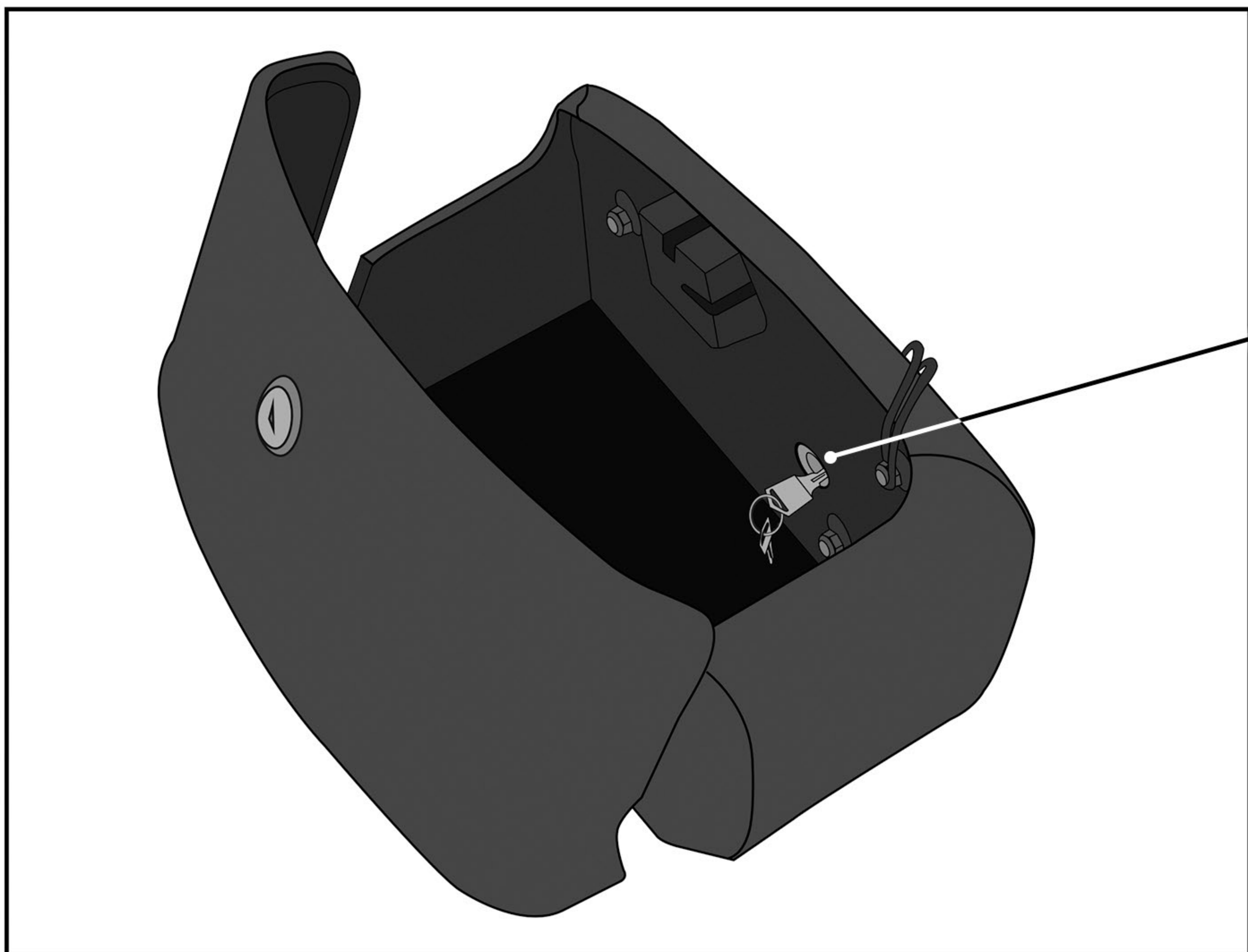

**Locking System**

**Locking System**

# Congratulations, your Viking Quick Mount SaddleBag is installed and you are ready to ride!

## Warnings!

- Do not install if any of the mounting hardware are damaged or impaired.
- If you have any questions or concerns about the installation, call Viking Bags or consult your local mechanic
- Ensure no part of the bag constructs any of the moving parts of the bike
- Viking Bags is not liable for any damage or malfunctions caused to your motorcycle during the installation process
- Improper loading can cause vehicle handling problems leading to death or severe injury.
- Periodically check the bolts on your bike for tightness.