

Viking ADX Tank Bag With Hydration Pack Installation:



Parts:

- | | | |
|-----|------------------------|-----|
| i | Zip Lock Ties | x 4 |
| ii | Rain Cover | x 1 |
| iii | 2 Liter Hydration Pack | x 1 |

Note:

- When looping the harness, ensure that no wires or cables are clipped. Make sure that the harness does not shift the handlebars from one side to the other to obstruct steering. Check that the harness does not constrict any wires, cables, or hoses as the handlebars are turned.
- If you adjust the front harness once. Even if the tank bag is removed, it does not need to be adjusted for the following rides.
- In some cases, the front of the tank bag may come into contact with the handlebar, which is fine as long as it does not interfere with the motorcycle's controls.
- When wrapping the zip tie for the rear strap make sure it is not in contact with the exhaust of the motorcycle.
- After installation is complete make sure the straps are long enough to go around your waist when the tank bag is transformed into a backpack. It is not necessary to cut the strap because the Velcro keeper will secure any extra strap length.

Instructions:

Step 1

Use the included harness (Fig 1.) to strap around the front frame of the bike. The buckles should be facing the rear of the bike (Fig 2.)

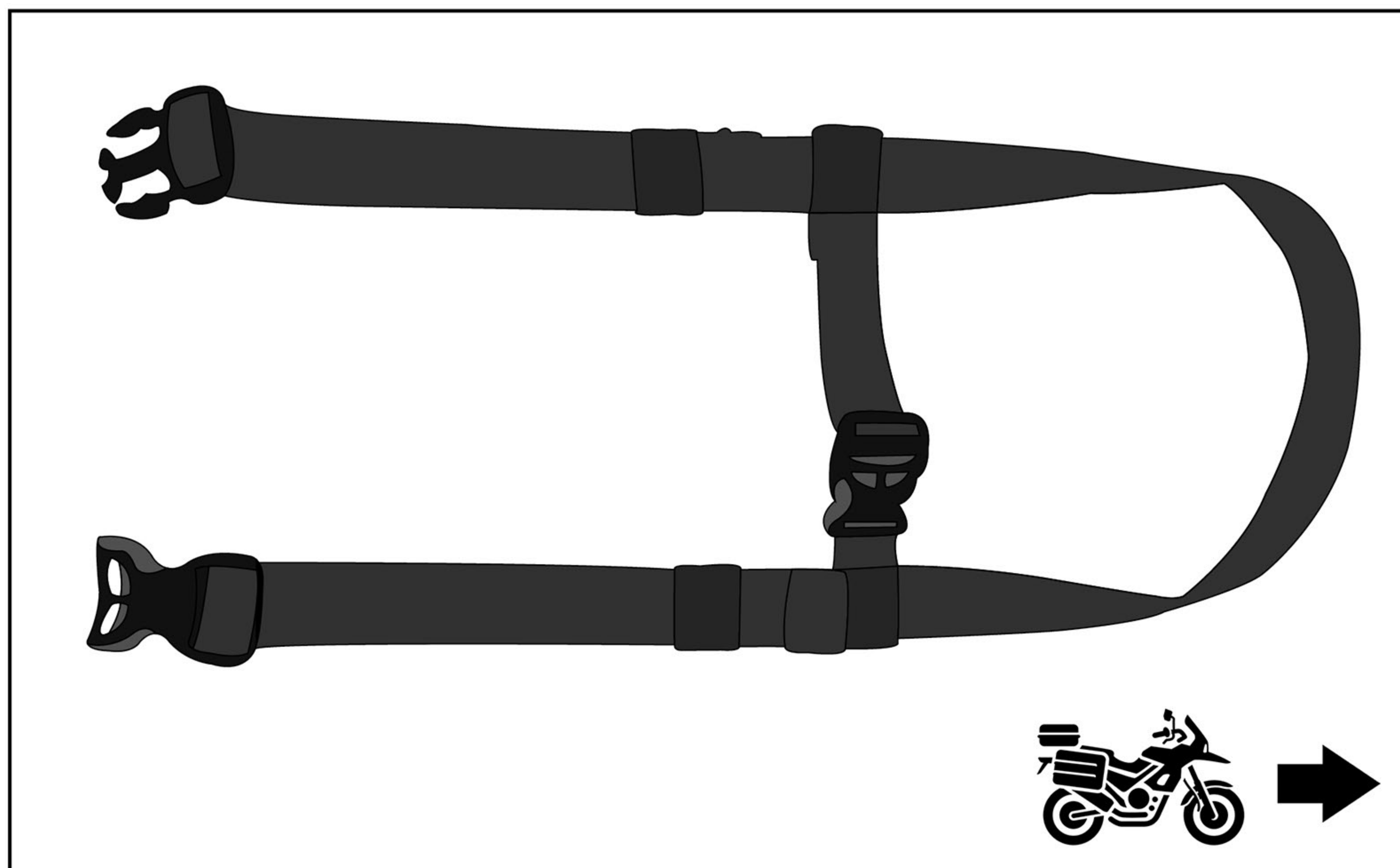

(Fig 1) Front Harness

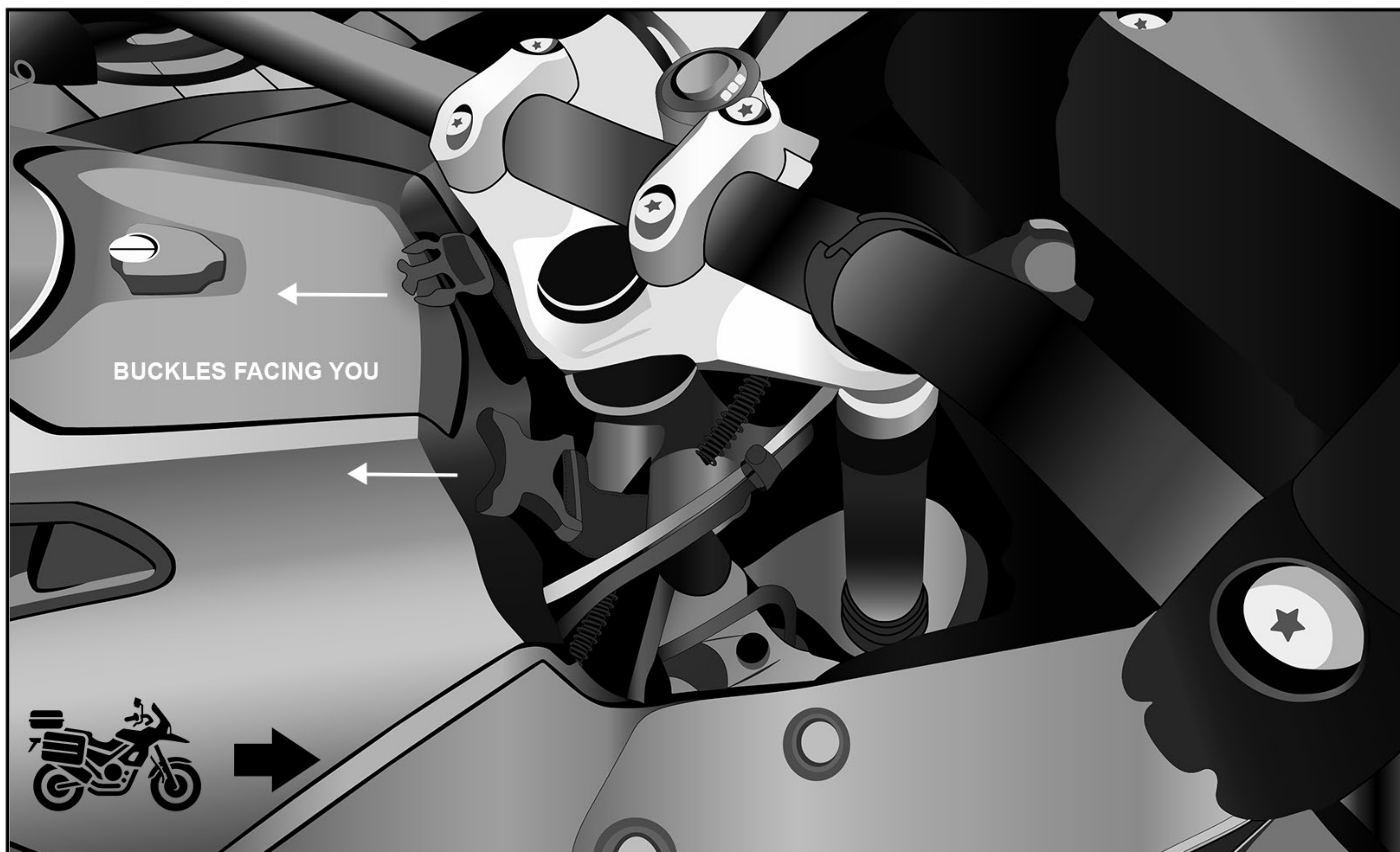

(Fig 2) Front harness mounted

Step 2

Now loosen the straps and attach the tank bag to the front harness. Tighten both straps until you find a suitable position for the tank bag.

Step 3

Pick a mounting point on the lower frame of the motorcycle that is close to where the rear straps fall. Wrap a zip tie around the mounting point, being careful not to clench any wires or cables. (See Fig 3.) Use 2 zip ties to secure the mount and cut off the excess zip tie with a plier (Fig 4.)

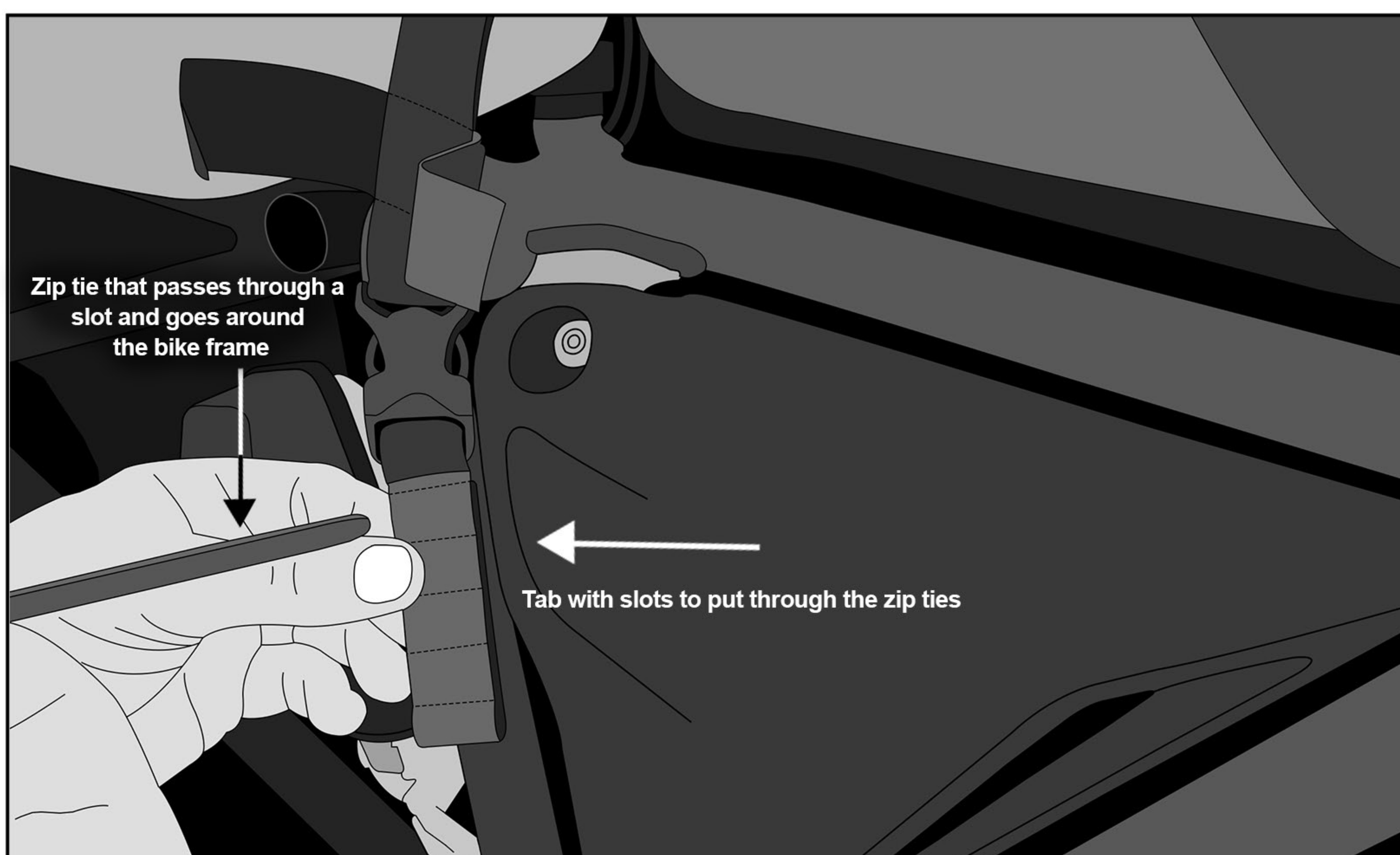

(Fig 3) Wrapping the zip tie around the motorcycle frame

Step 4

Repeat the same for the other side.

Step 5

Adjust the length of both the rear straps, pull them tight and close the velcro. To secure the extra strap length, fasten the velcro keeper at the bottom of the strap.



(Fig 4) Once both zip ties are tight and secure, cut off the access zip ties that are hanging

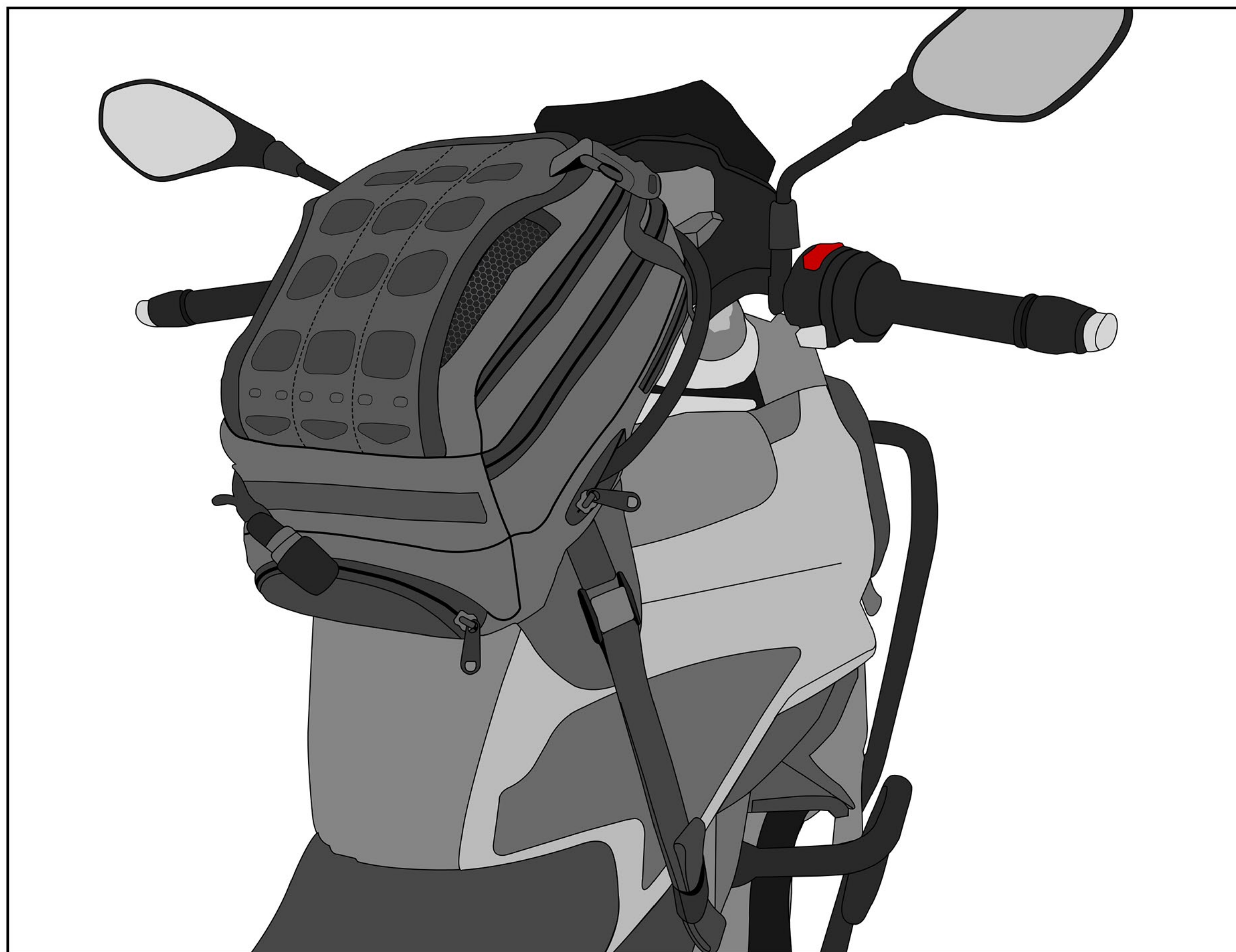

(Fig 5) Viking ADX Tank Bag Mounted

Congratulations! You have installed The Viking ADX Tank Bag with Hydration Pack

Warnings !

- Avoid using any mounting part that is impaired or not working properly.
- Periodically check the installed product to ensure all bolts are tight.
- Do not install the product if you are unsure about any of the installation steps.
- Viking Bags is not responsible for any damage caused by improper use of the product.
- No part of the product should obstruct the functioning of your bike.