

Viking Quick Disconnect Saddlebag for Triumph Speed Twin 900:



Parts:

i	Mounting Bracket	x1
ii	Docking Post	x3
iii	Locking Bolt	x1
iv	Socket Head Screw - M6 x 20	x1
v	Flathead Screw - M6 x 20	x2
vi	Street Twin / Scrambler Bracket	x1
vii	Street Cup Bracket	x1
viii	Roundhead Screw - M8 x 20	x1
ix	Round-Head Screw - M8 x 16	x2
x	Roundhead Screw with Flange - M8 x 16	x2
xi	Spacers	x2

Note:

- i. The installation steps are identical for left or right mounting bracket and saddlebags. The illustrations in this manual show left side installation.

Parts Diagram:

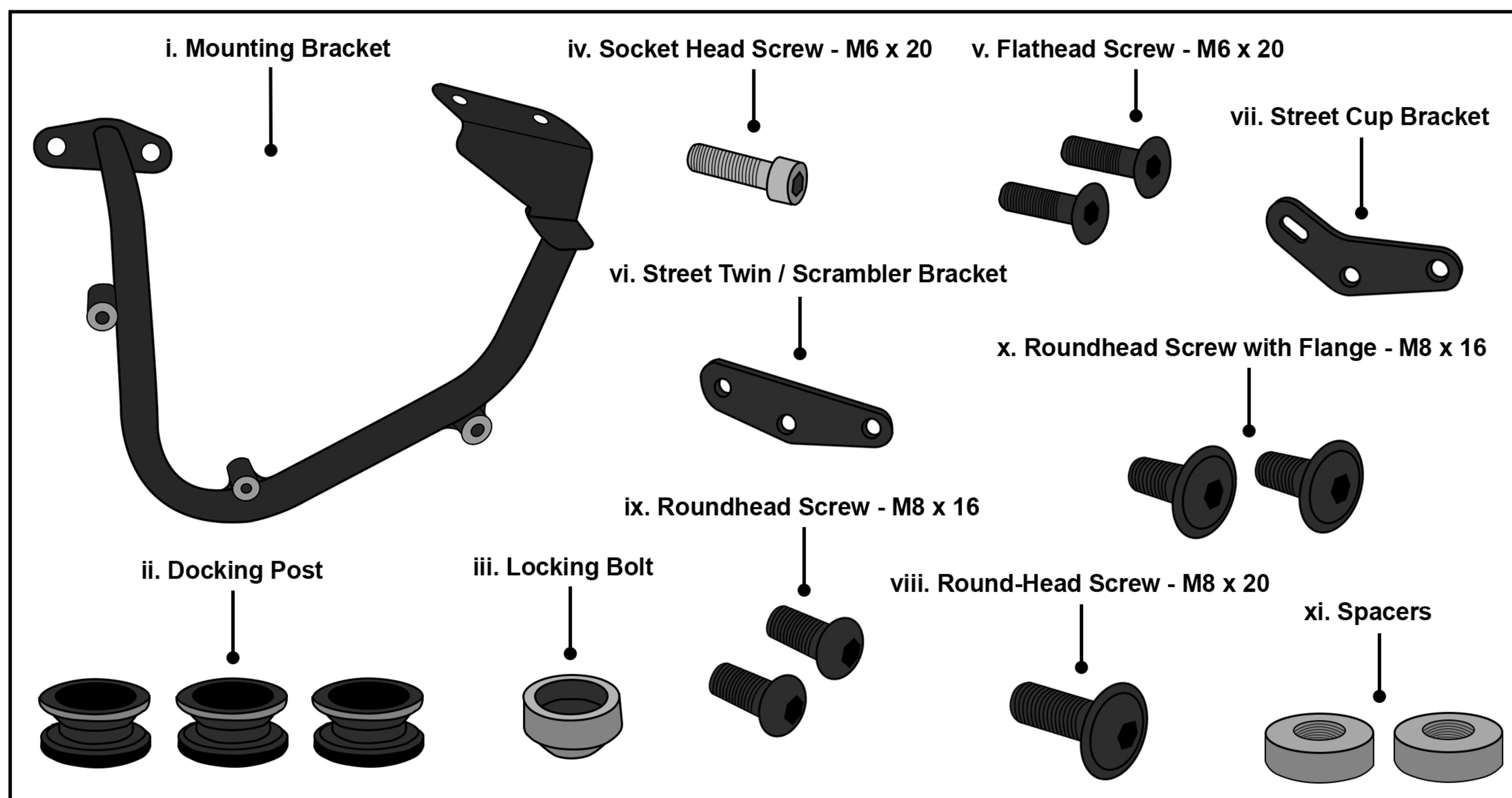

Installation Instructions:

Step 1:

Install the 3 Docking Posts (ii) and the Locking Bolt (iii) to the mounting bracket as shown in Figure 1. We recommend using blue loctite for securing the screws. Use medium thread locker (loctite) & tighten to 7 N-m.

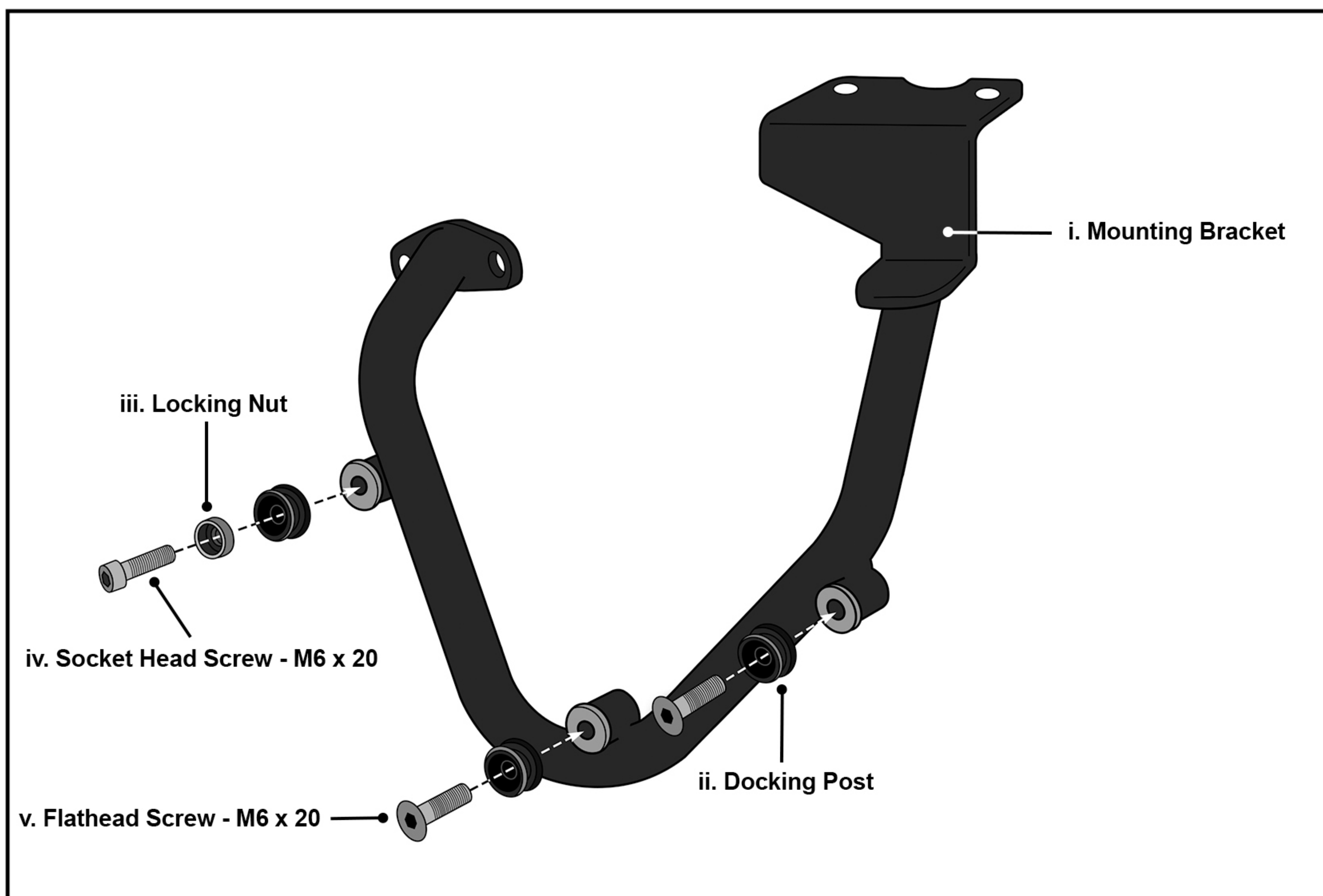

Fig 1. Assembling the Mounting Bracket

Step 2:

Street Scramble: Remove the passenger seat and remove the 4 OEM rear screws as shown in figure 2.

Street Twin / Street Cup: Remove the passenger seat from you motorcycle.

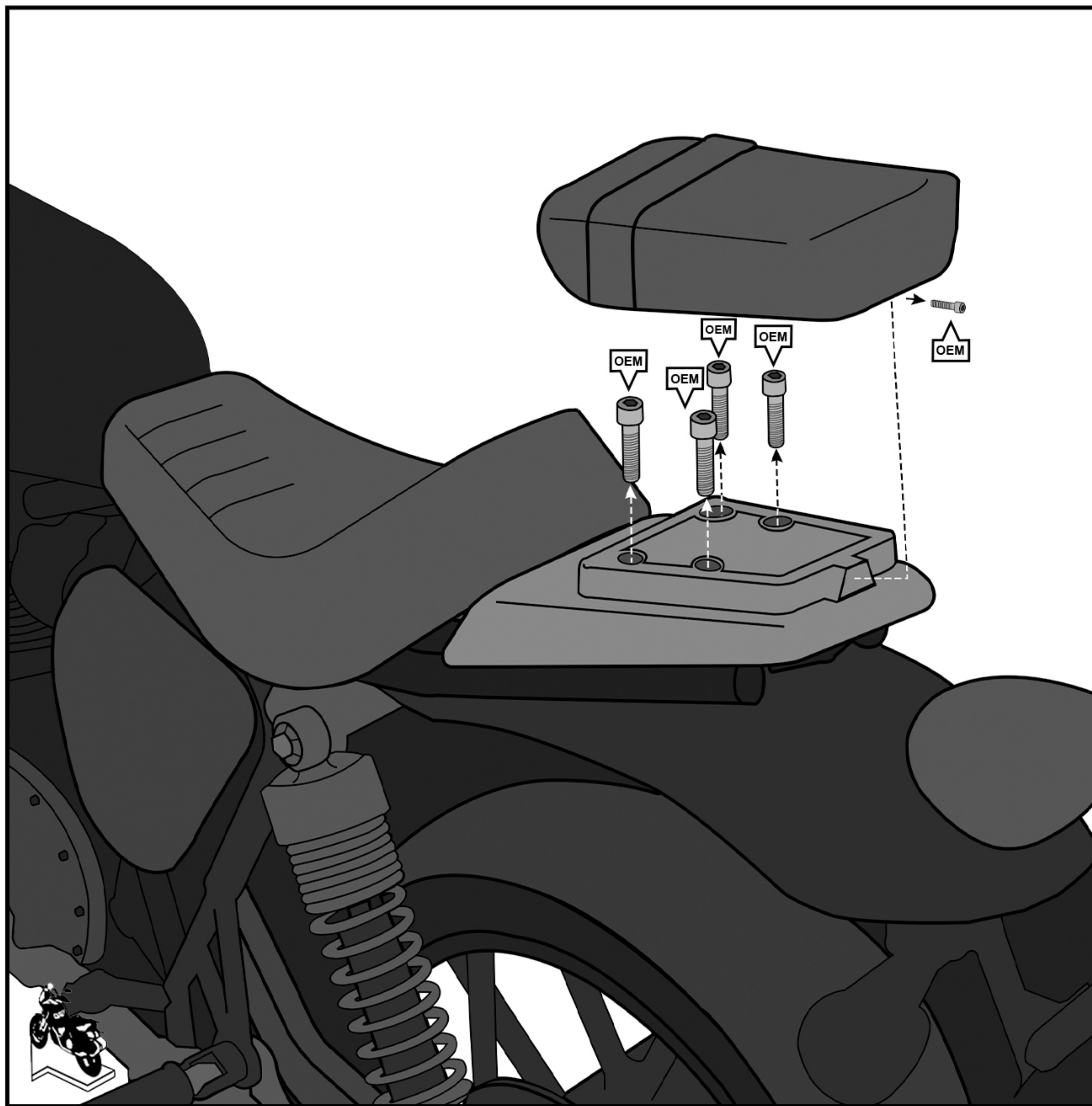

Fig 2. Removing the Seat

Step 3:

Depending on your bike, attach the Street Twin/ Scrambler Bracket (vi) or Street Cup Bracket (vii) behind the shock using the provided roundhead screw (viii). Note that you must only install one of the 2 brackets, based on your bike model.

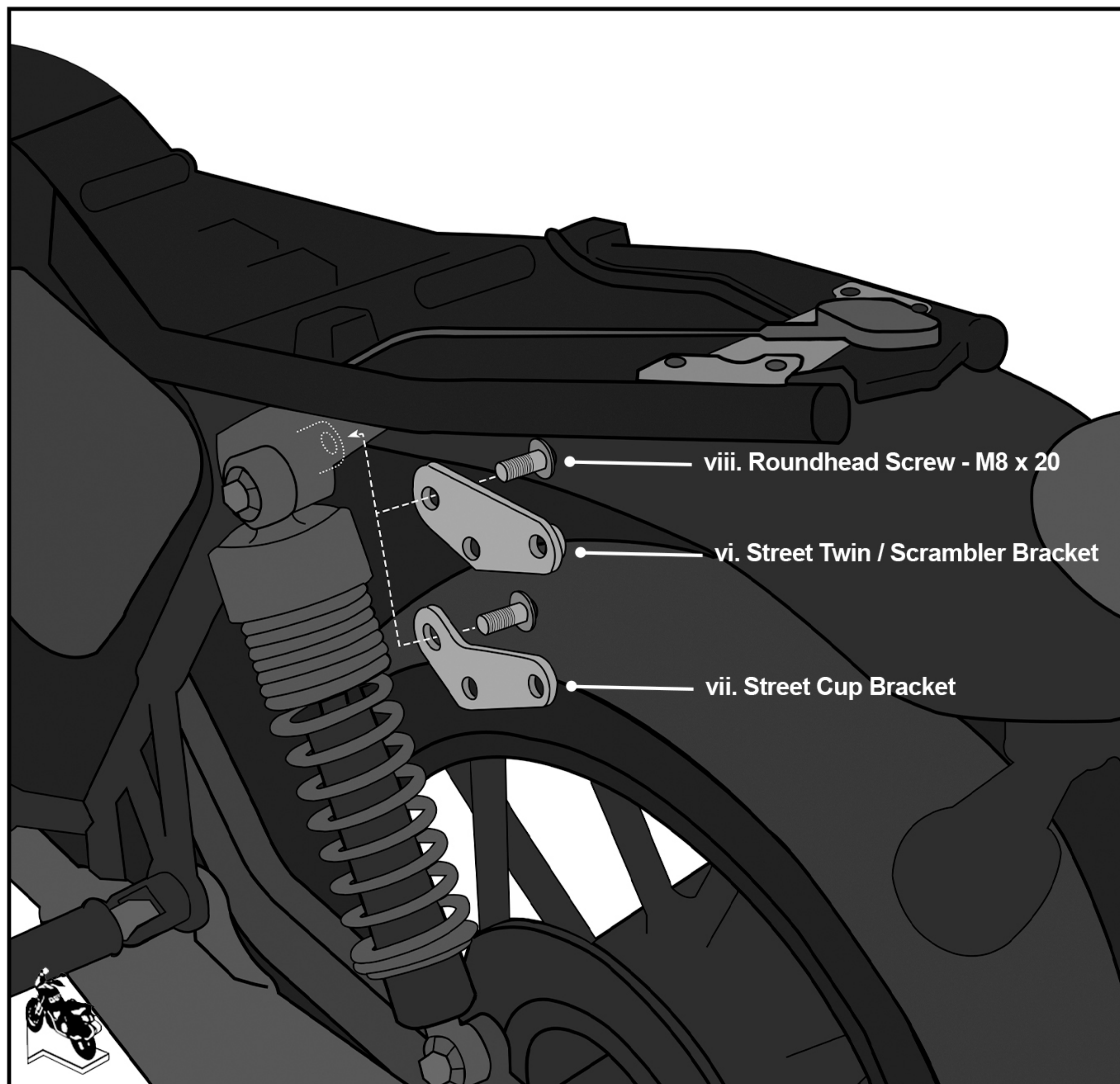

Figure 3. Installing the Bike-Specific Bracket

Step 4:

This step is for Street Twin. Skip to step 5 for Scrambler and Street Cup Models.

Attach the mounting bracket (i) to the bike using the provided screws (ix and x). Note that the mounting bracket attaches to the bike using 2 holes on the frame of the bike and 2 holes in the previously installed bike-specific bracket. See Figure 4.

Use the medium thread locker and tighten to 20 N-m.

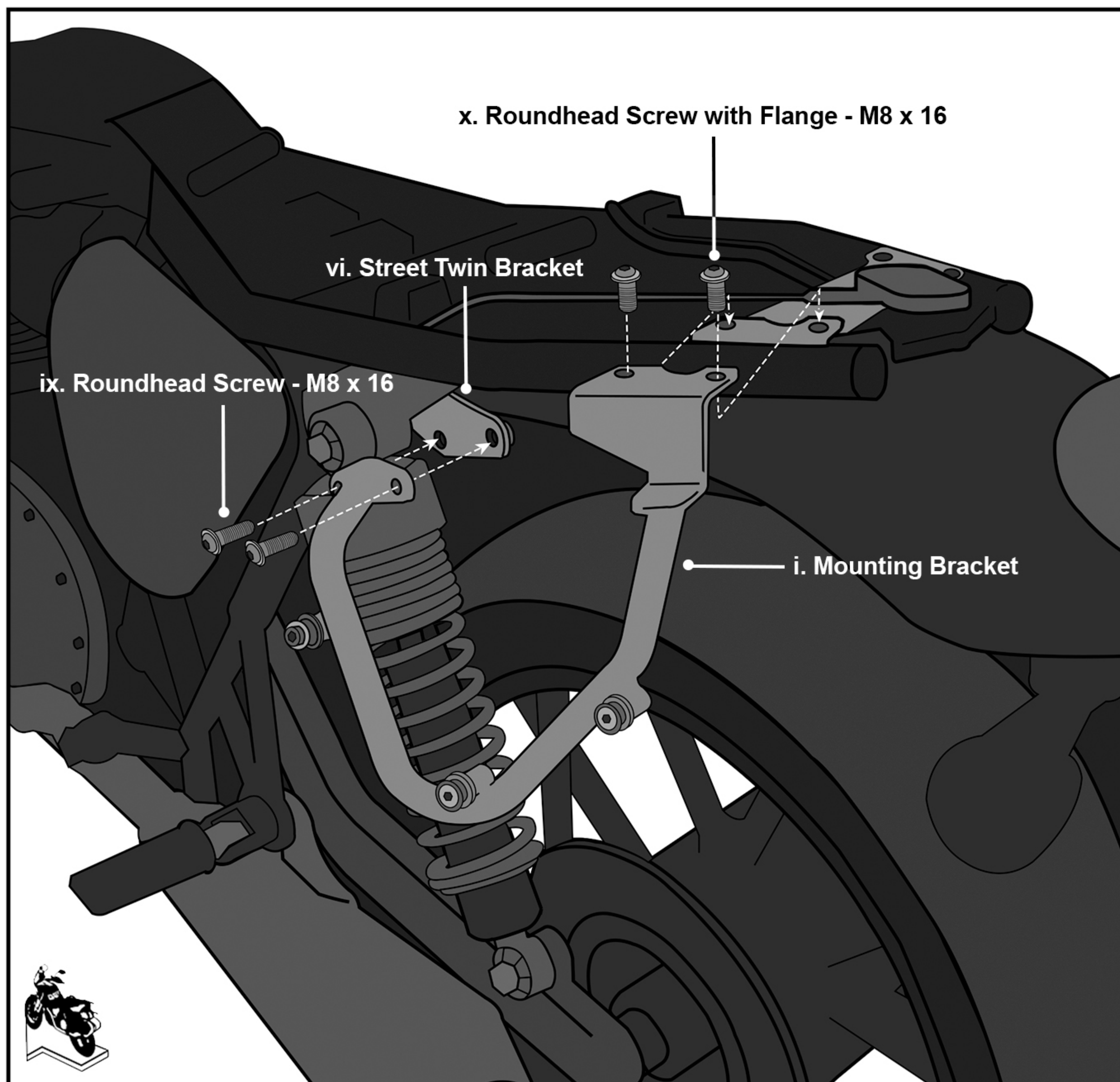

Figure 4. Installation for Street Twin

Step 5:

This step is for Scrambler and Street Cup models only.

Attach the mounting bracket (i) to the bike using the provided screws (ix and x). Note that the mounting bracket attaches to the bike using 2 holes on the frame of the bike and 2 holes in the previously installed bike-specific bracket.

For Scrambler models, use the two provided spacers (xi) on the opposite end to keep the seat level. See Figure 5.

For Street Cup models, use the provided spacers (xi) under the seat locking assembly. See Figure 6.

Use the medium thread locker and tighten to 20 N-m.

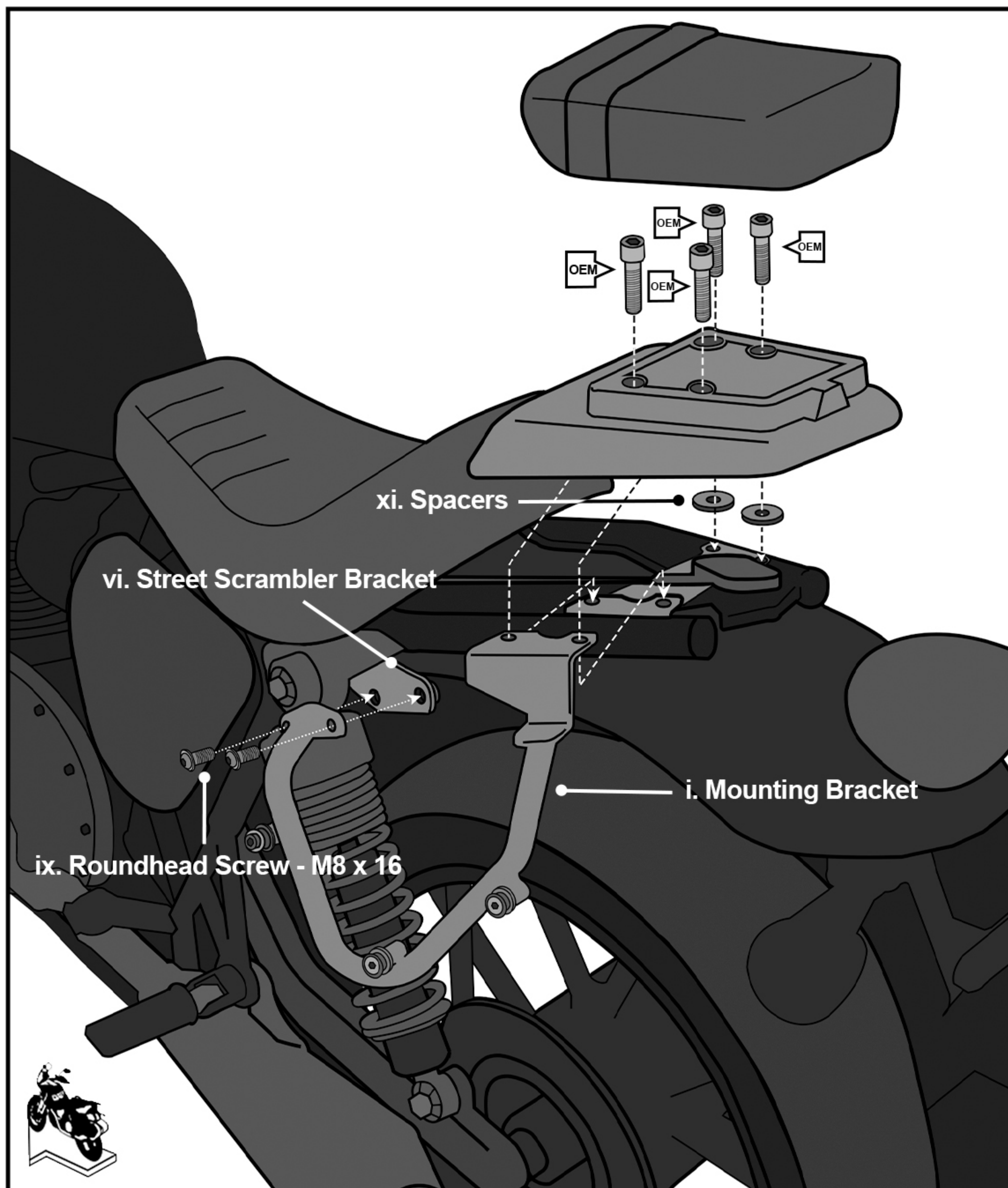

Figure 5. Installation on Scrambler Models

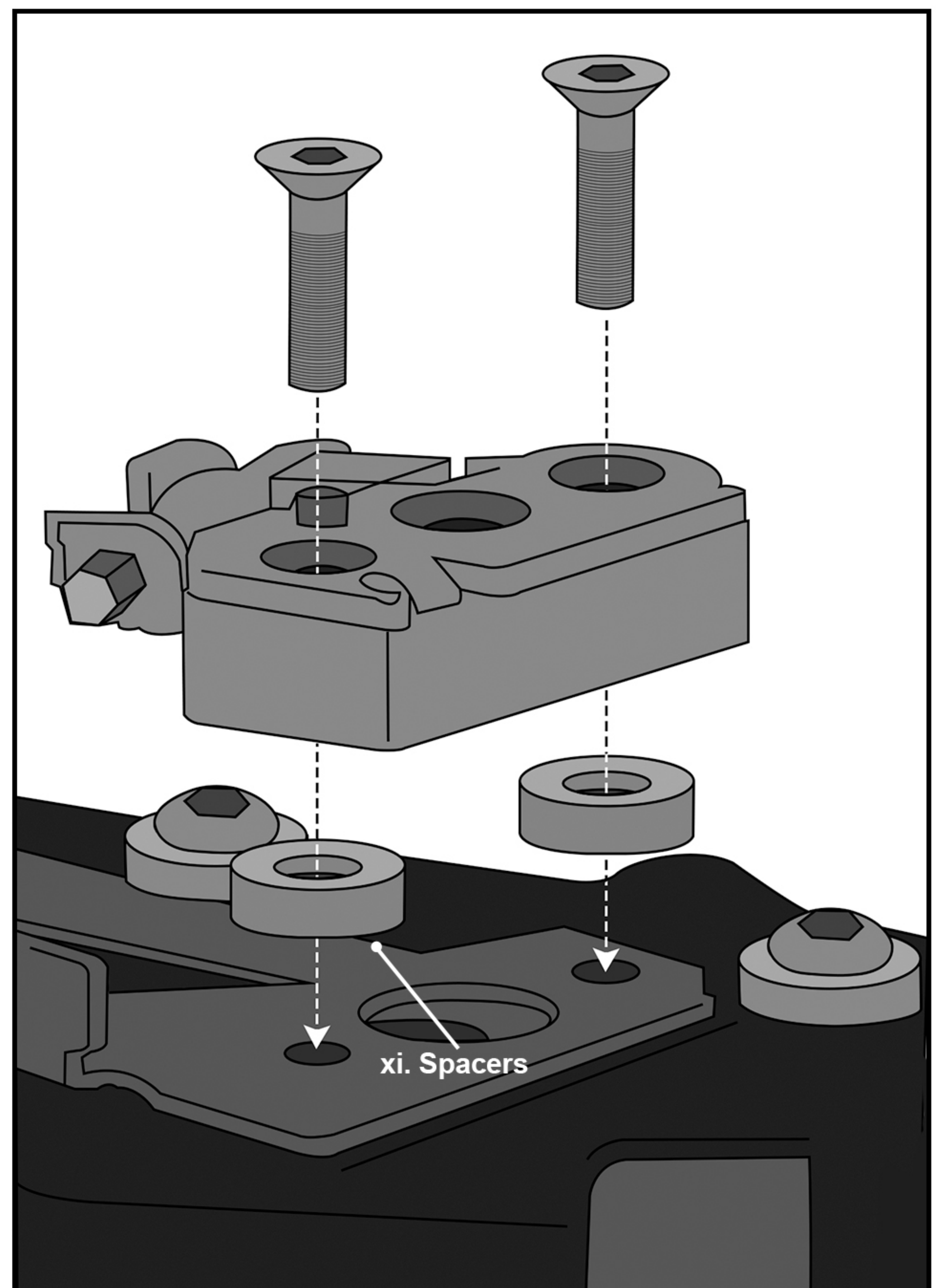

Figure 6. Installation on Street Cup Models

Step 6:

The back of the bag comes equipped with a quick disconnect bracket.

Attach the bag to the mounting bracket by aligning the holes in the quick disconnect bracket with the 3 docking posts. Push the bag downwards so that the docking posts engage with the grooves in the bracket and the bag locks in.

Pull the lever to disengage the lock and remove the bag.

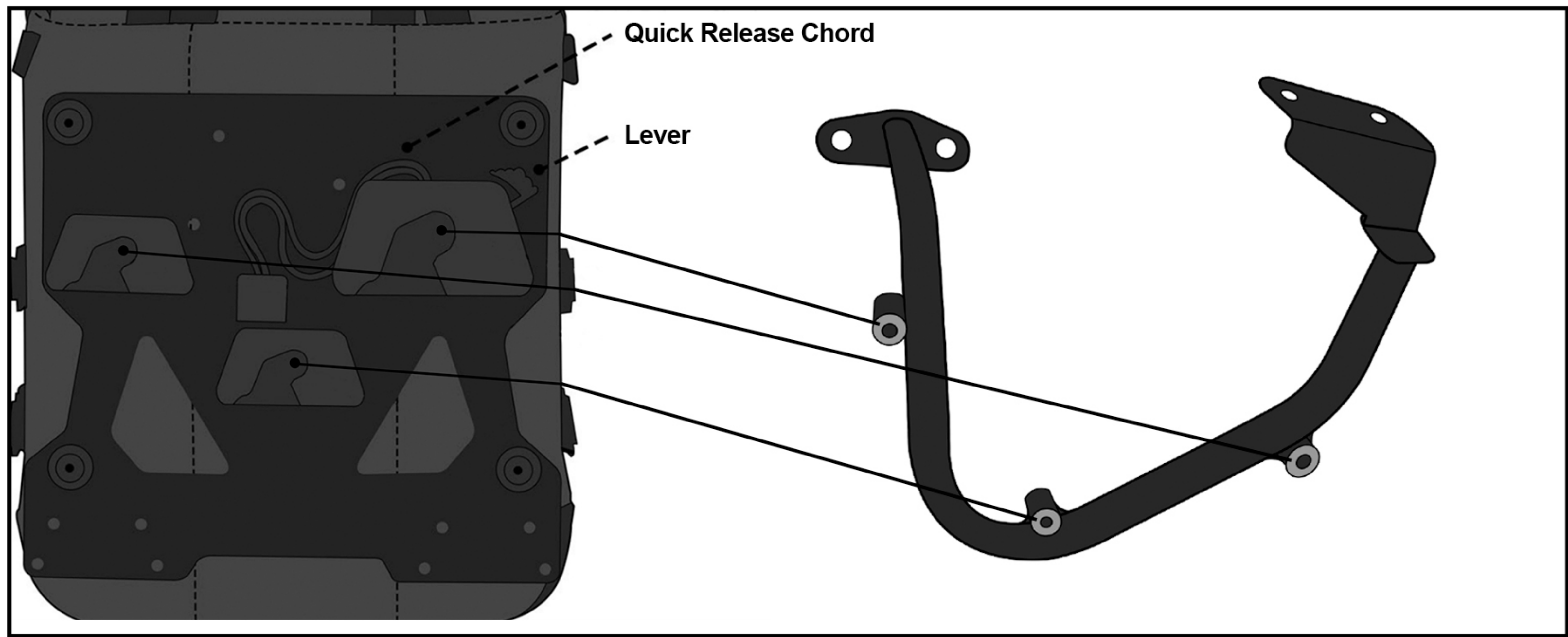

Tip:

The quick disconnect system is key lockable. Lock / unlock the quick disconnect system from inside the bag to secure your bag against theft.

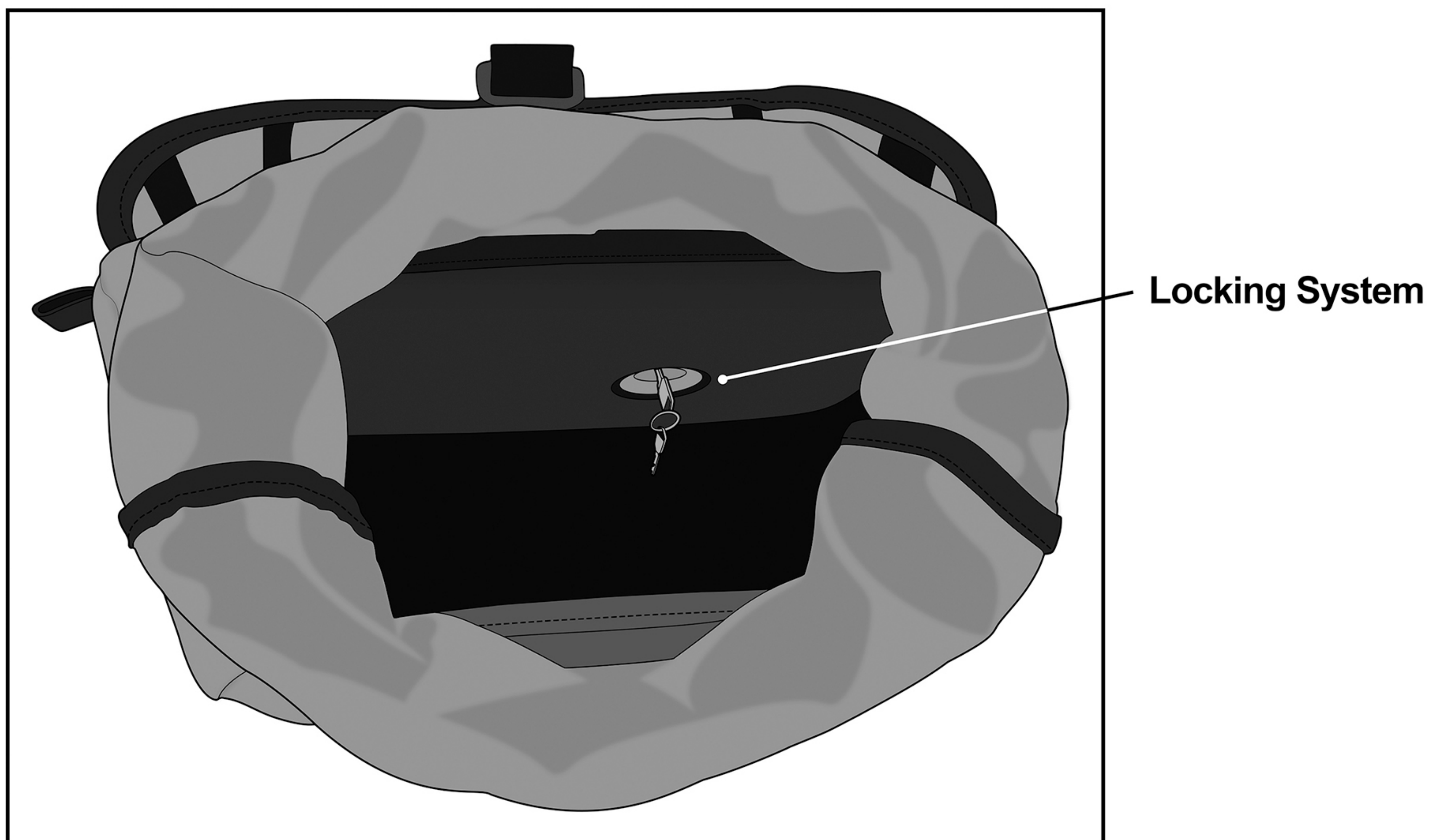

locking system located below the waterproof liner

Congratulations, your Viking Incognito Solo Bag is installed and you are ready to ride!

Warnings!

- Do not install if you are unsure about any of the installation steps.
- No part of the bag or mounting bracket should obstruct any of the moving parts of the bike such as the wheels or drive-train.
- Viking Bags is not responsible for any damage or injury caused by improper installation or use of the product.