

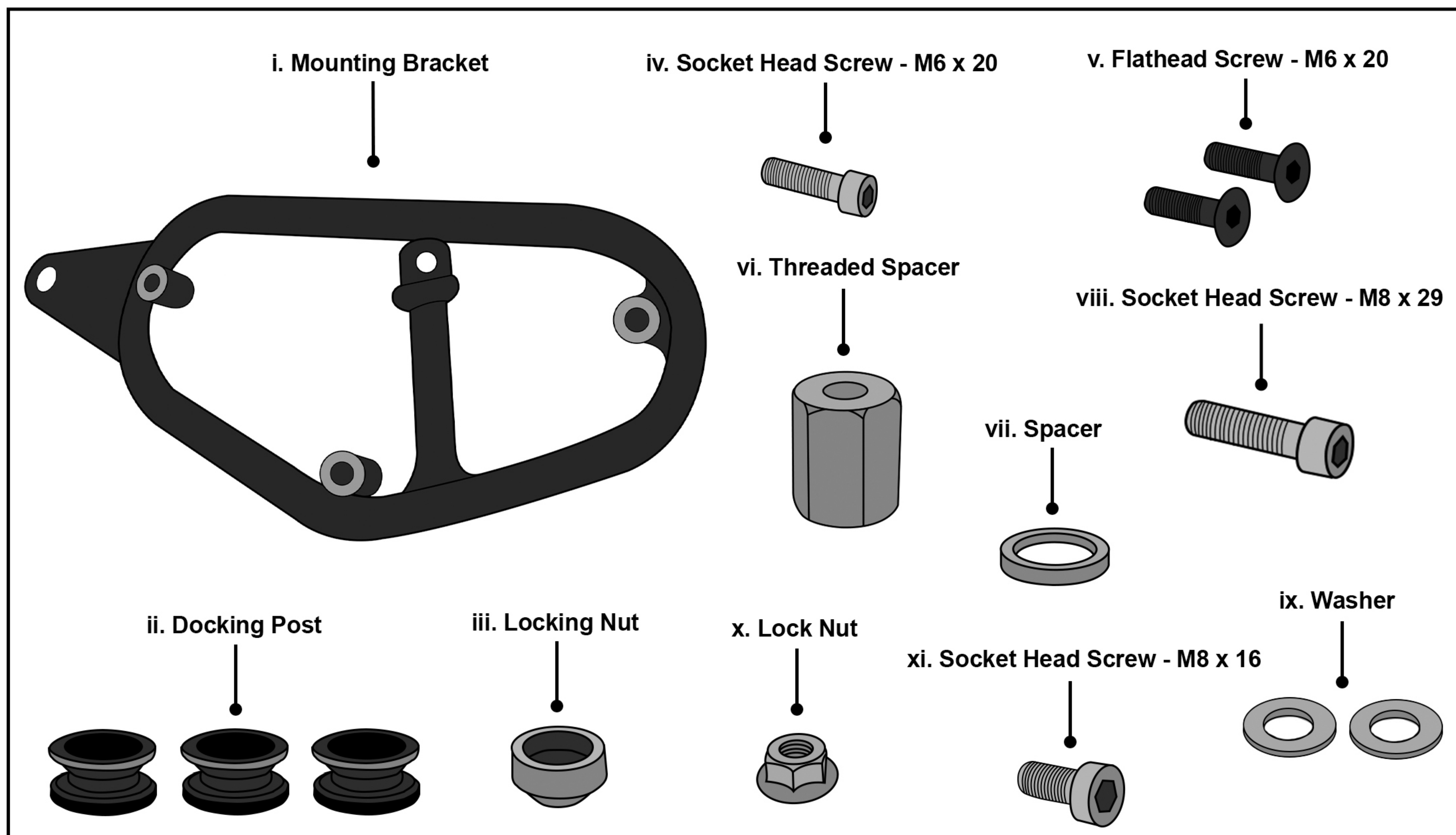
# Viking Quick Detachable Saddlebag Installation for Kawasaki W800, W650:



## Parts:

|      |                             |    |
|------|-----------------------------|----|
| i    | Mounting Bracket            | x1 |
| ii   | Docking Posts               | x3 |
| iii  | Locking Bolt                | x1 |
| iv   | Socket Head Screw - M6 x 20 | x1 |
| v    | Flathead Screw - M6 x 20    | x2 |
| vi   | Threaded Spacer             | x1 |
| vii  | Spacer                      | x1 |
| viii | Socket Head Screw - M8 x 29 | x1 |
| ix   | Washer                      | x2 |
| x    | Lock Nut                    | x1 |
| xi   | Socket Head Screw - M8 x 16 | x1 |

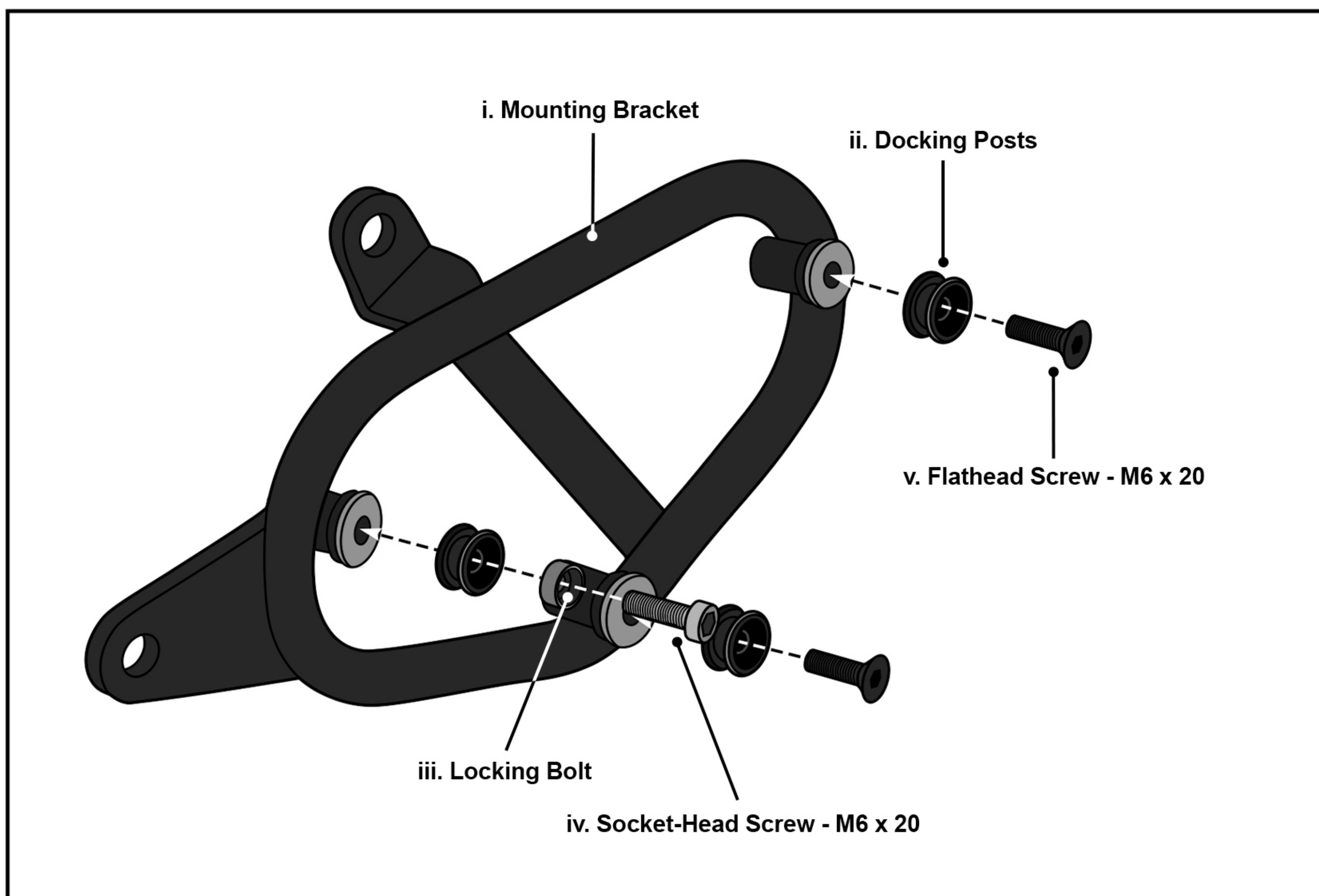
## Parts Diagram:



## Installation Instructions:

### Step 1:

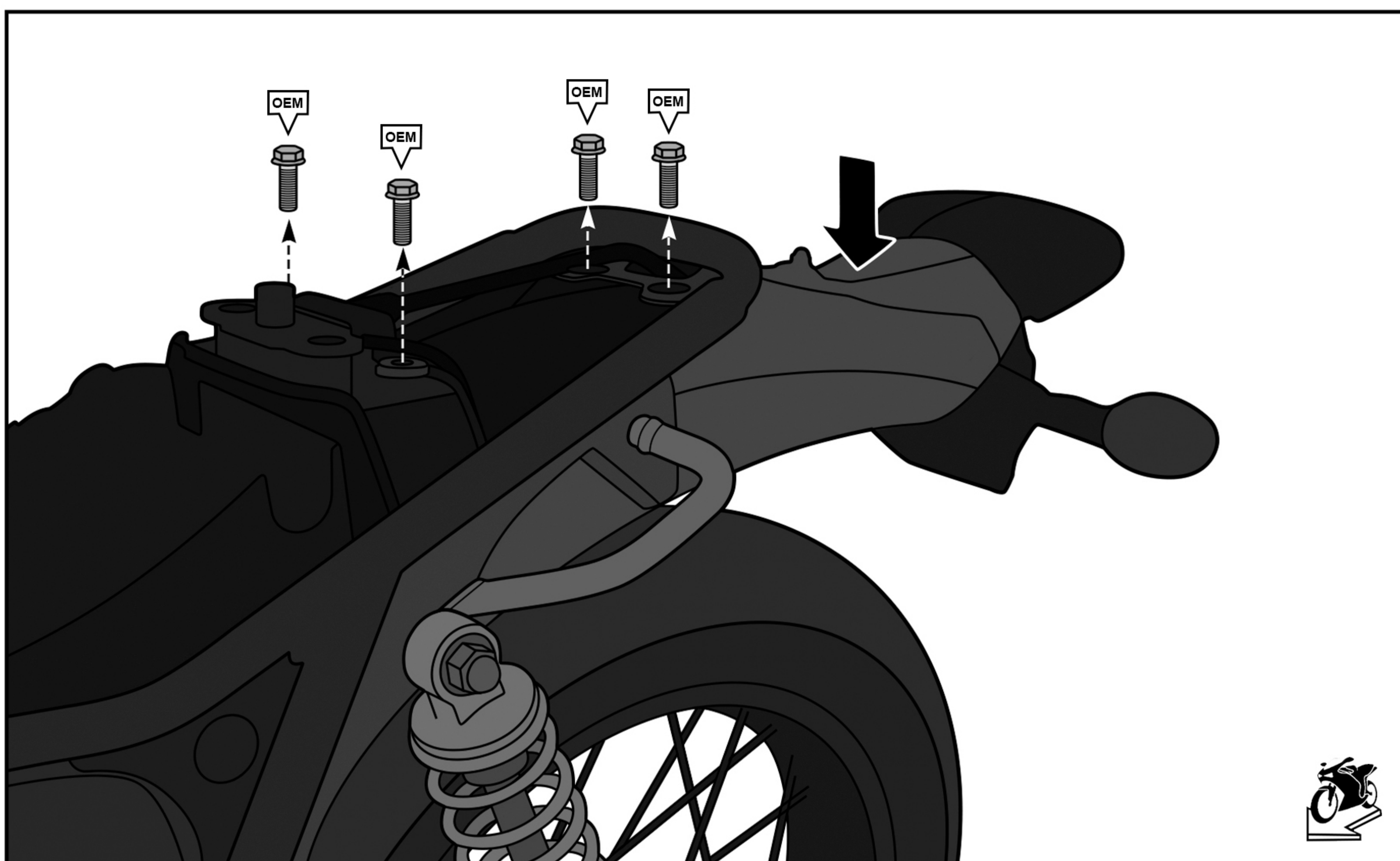
Install the 3 Docking Posts (ii) and the locking nut (iii) to the mounting bracket as shown in Figure 1. Use Flat-head screws (v) to mount the docking posts and Socket-Head Screw (iv) to mount the locking nut. Apply medium thread locker and tighten to 8 N-m of torque.



**Fig 1. Assembling the Mounting Bracket**

## Step 2:

Remove the rear seat and the 4 screws holding the mudguard to the frame. See Figure 2.



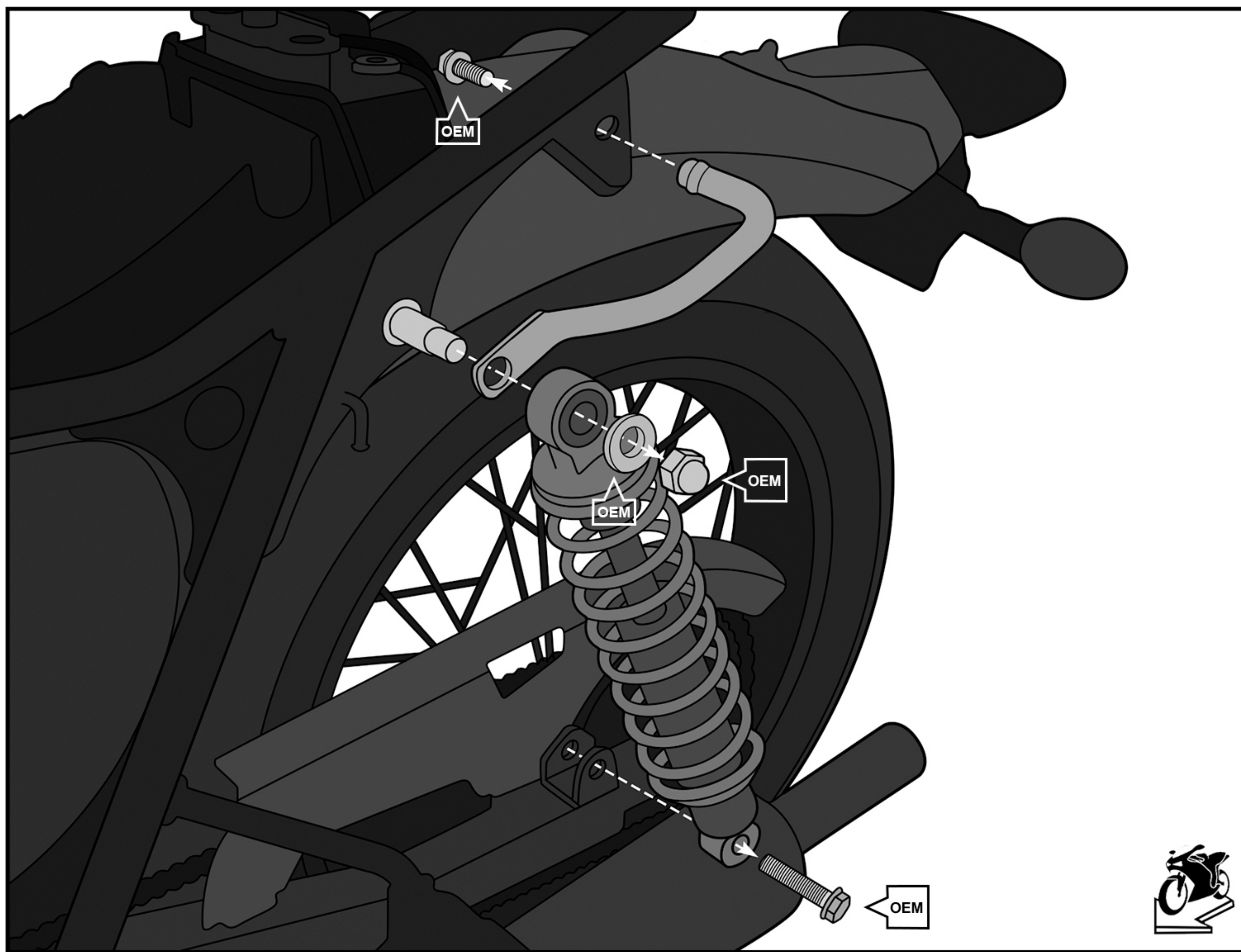
**Fig 2. Removing Mudguard**

## Step 3:

Raise your motorcycle using a jack so the weight is off the rear tire.

Remove the rear shock and the passenger grip from your motorcycle. See Figure 3.

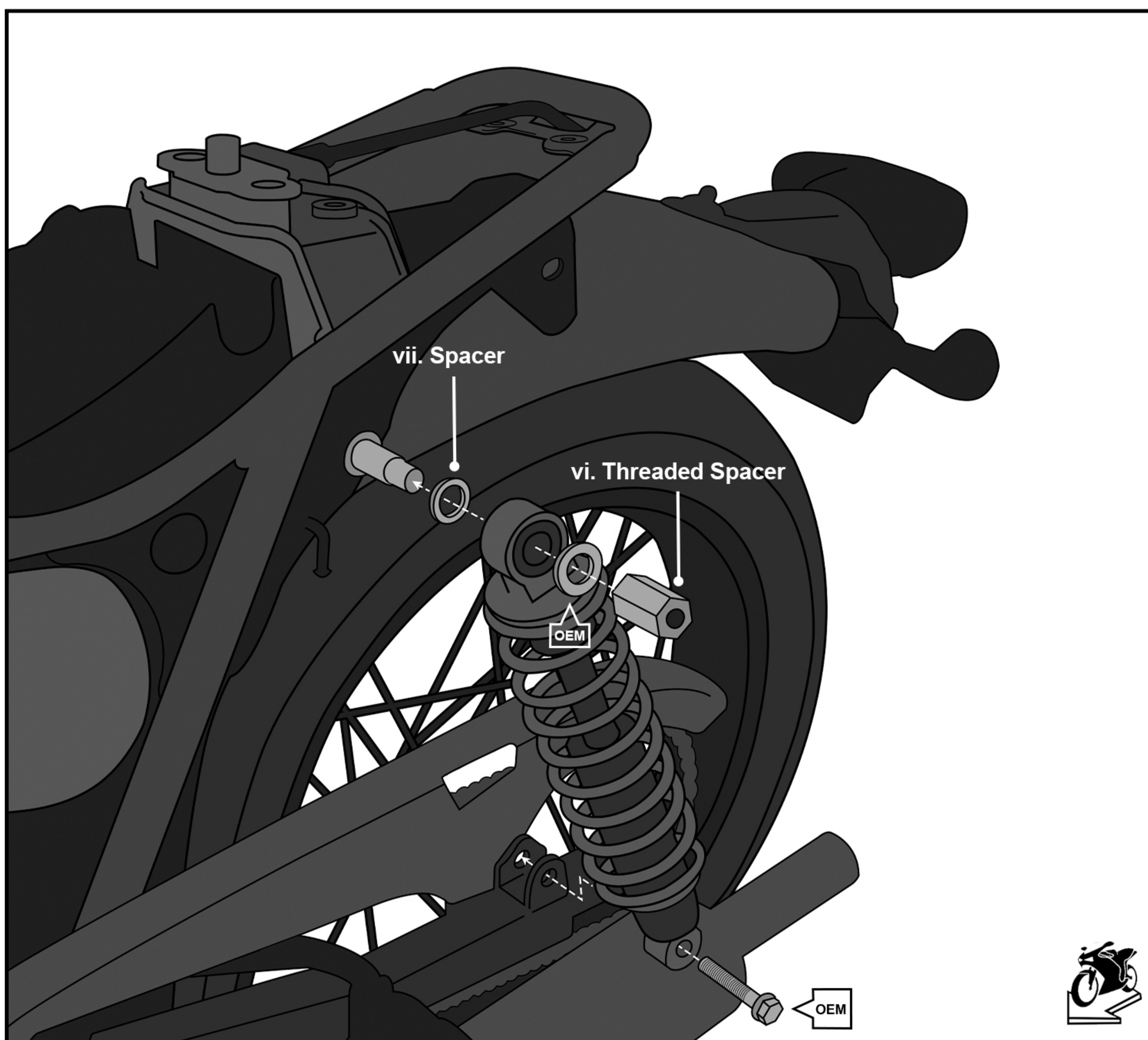




**Fig 3. Removing Rear Shock and Passenger Grip**

**Step 4:**

Reinstall the shock with the provided spacer (vii) and the provided thread spacer (vi) - Figure 4.



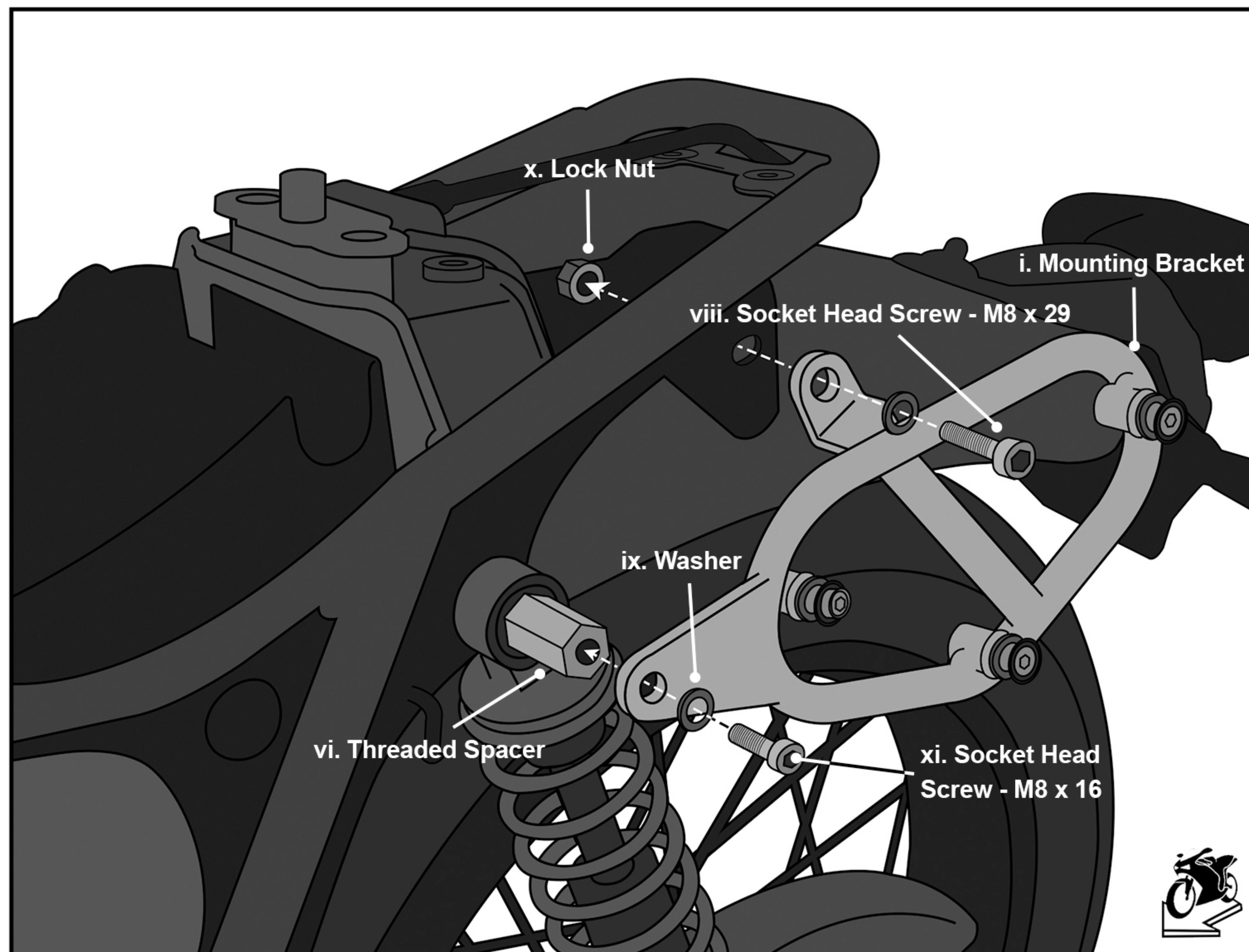
**Fig 4. Reinstalling the Shock**

**Step 5:**

Attach the mounting bracket to the motorcycle using the provided M8 bolts (viii & xi) and washers. Note that the longer bolt goes in the rear and the shorter bolt goes in the front. See Figure 5..



Apply medium thread locker and tighten screws to 22 N-m.



**Fig 5. Attaching the Mounting Bracket**

### **Step 6:**

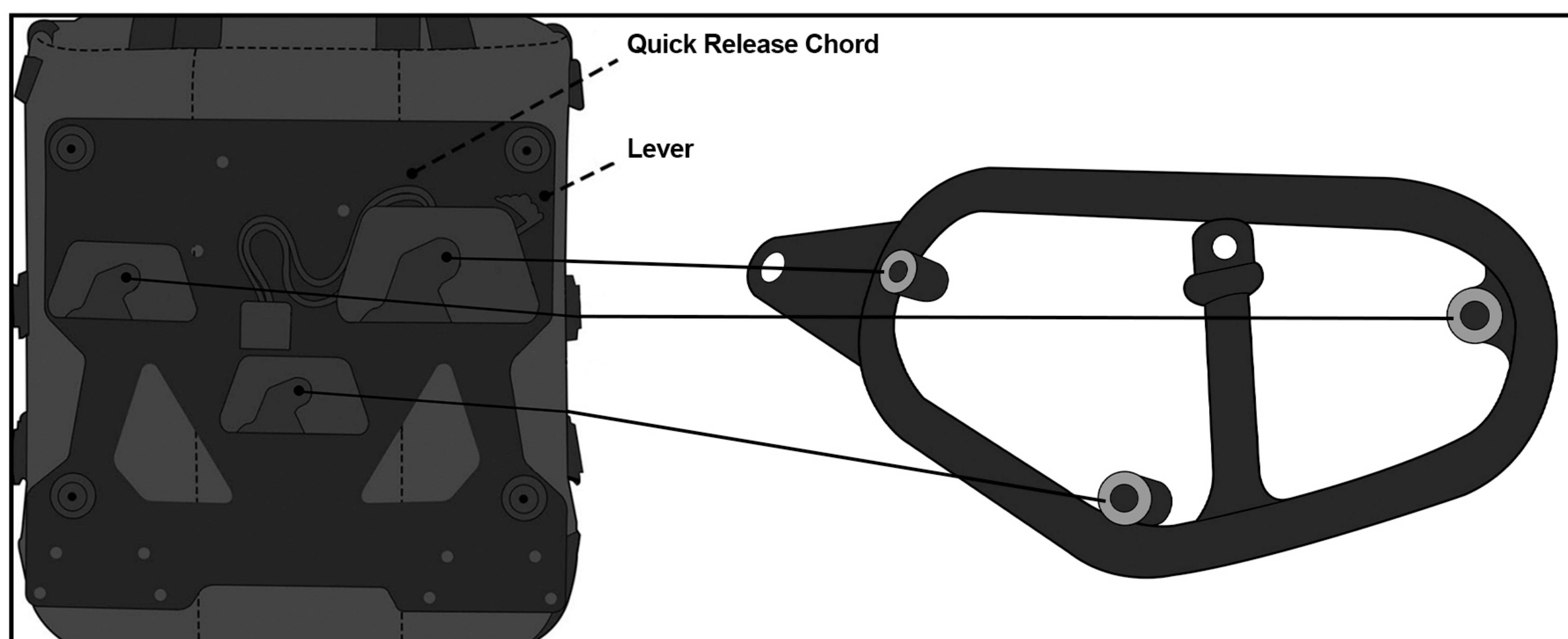
Reinstall the mudguard using the 4 OEM bolts removed in step 2.

### **Step 7:**

The back of the bag comes equipped with a quick disconnect bracket.

Attach the bag to the mounting bracket by aligning the holes in the quick disconnect bracket with the 3 docking posts. Push the bag downwards so that the docking posts engage with the grooves in the bracket and the bag locks in. See Figure 4.

Pull the lever to disengage the lock and remove the bag.

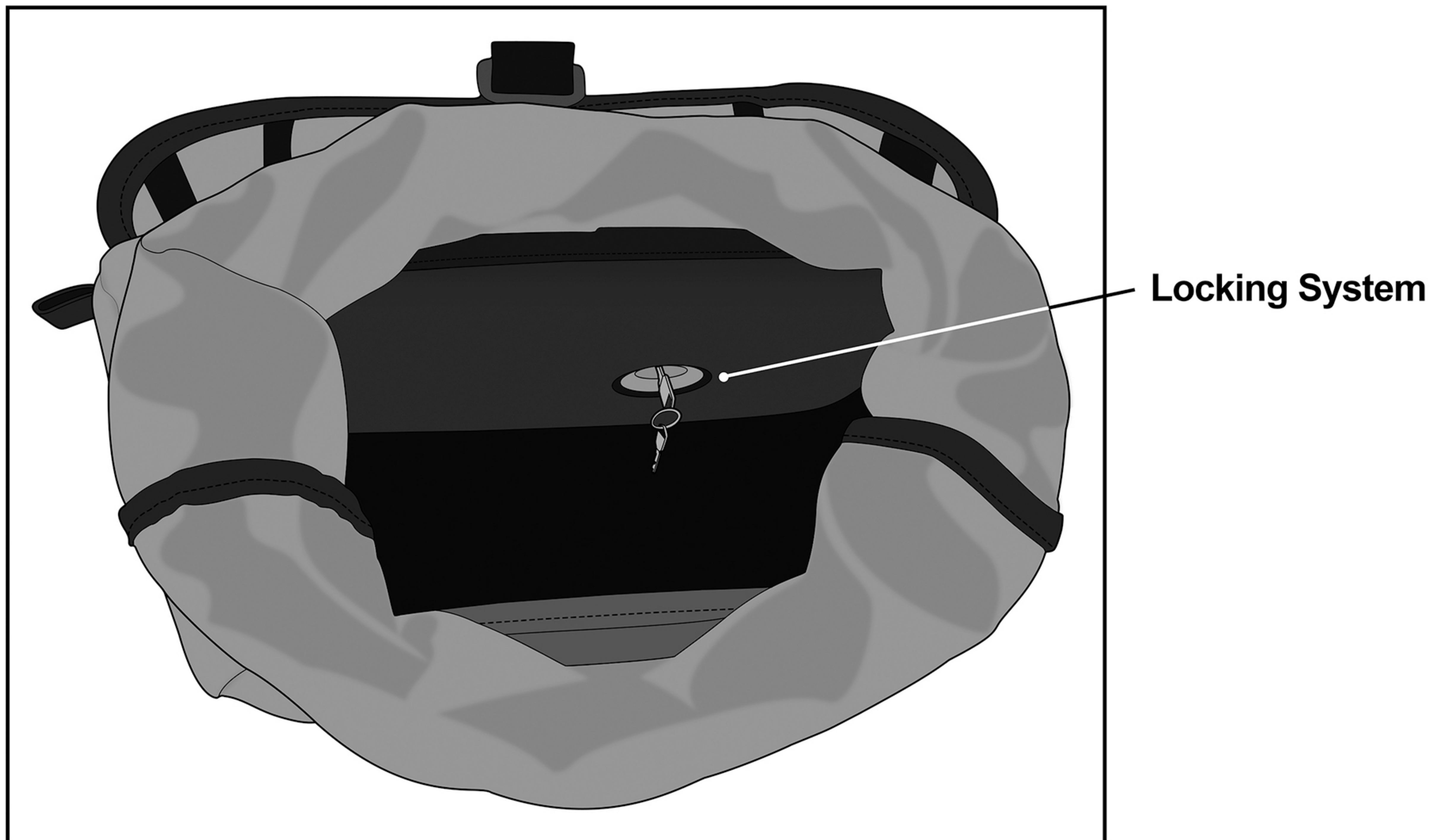


**Fig 6. Attaching the Saddlebag**



## Tip:

The quick disconnect system is key lockable. Lock / unlock the quick disconnect system from inside the bag to secure your bag against theft.



locking system located below the waterproof liner

**Congratulations, your Viking Incognito Solo Bag is installed and you are ready to ride!**

## Warnings!

- Do not install if you are unsure about any of the installation steps.
- No part of the bag or mounting bracket should obstruct any of the moving parts of the bike such as the wheels or drive-train.
- Viking Bags is not responsible for any damage or injury caused by improper installation or use of the product.