

paua

paua ValkBox

Halterung

Montageanleitung



Index

Disclaimer	Page 3
Required ballast	Page 4
Safety instructions	Page 5
Required ballast per country	Page 6 - 17
Components	Page 18
Mounting the clevis	Page 19
Mounting the curved supports	Page 19
Mounting panel options	Page 20
Placing the rubber tiles	Page 21
Position the ballast	Page 21
Tighten hinge bolts B1	Page 22
Finish fitting the cables	Page 22
Position the rows one behind each other	Page 22

Pay attention

- This manual is not project specific.
- This manual is not legally binding.
- No rights may be derived from this installation manual.
- See **datasheet ValkCableCare** for cable management.
- The system is placed in the middle zone of the roof.





Disclaimer

This installation manual composed with the greatest possible care and contains specific information for correct and safe installation of the solar mounting system, including installation drawings and ballast tables, calculated according to the Eurocode regulations. The standard values used for input of these calculations, always need to be checked in advance by the installer for correctness. In case values are different, a project case specific calculation needs to be made. Please contact Van der Valk Solar Systems in this situation.

At all times all currently applicable structural, safety and building regulations must be observed prior to installation of the solar mounting system. The building in question will be subject to a load as a result of the solar mounting system installed/mounted. Solar mounting systems installed on roofs will be exposed to wind and snow loads. Therefore, you are at all times responsible to obtain and use a design calculation to establish whether or not the building will be able to withstand the (extra) load at all times. Where necessary, modifications need to be made by you. Van der Valk will not accept any form of liability upon you not having obtained and used such a required design calculation.

Mounting systems for PV-panels placed on flat roofs should either be mechanically attached to the roof or need to be supported by ballast, to make sure that the solar mounting system is unable to be lifted, tipped over or slide. The required ballast weight per system shown in the tables in this manual ensures that the mounting system can be installed and used safely. In case the inclination of the roofs is 5 degrees or more, the PV-mounting system must always be mechanically fixed to the construction of the roof.

The calculations do not take into account obstacles in the near surrounding such as, for example, high buildings, cliffs and mountains. Restrictions also apply for the position of the solar mounting system on a roof. The solar panels must be installed at a certain distance from the edge of the roof: the middle zone.

The standard warranty is 10 years, which can be extended under certain conditions. The warranty provided is subject to the warranty conditions stated in the general terms and conditions stipulated by Van der Valk Solar Systems B.V. Our terms and conditions shall apply to all our products at all times and can be found on our website: www.valksolarsystems.com

Van der Valk Solar Systems B.V. does not accept any liability for any direct and/or indirect consequences of any act (or omission) ensuing from the information in or failure to observe the instructions provided in this installation manual. The use of the installation manual will at all times be subject to Dutch law.

Van der Valk Solar Systems holds the right to amend this document without further notice.



Safety instructions

The ValkBox3 mounting system is installed on roofs and will be exposed to wind and snow. The building in question will be subject to a greater load as a result of the PV system. A design calculation must be used to establish whether or not the building in question will be able to withstand the extra load. Where necessary, modifications will then need to be made.

When installing the ValkBox3 mounting system, the instructions provided in this user manual must be observed at all times. Read this manual carefully and keep it in a safe place. Also follow the instructions stated in the manuals for the other system components that form part of the overall PV system. All current structural, safety and building regulations must be observed. Van der Valk Solar Systems B.V. will never be liable for any direct and/or indirect intangible or consequential loss ensuing from or connected to the failure to observe the instructions provided in this manual.

Starting points

The following starting points apply for the ValkBox3 mounting system:

The standards applied (if applicable for specific solar mounting system)

NEN-EN 1990:	Eurocode – Basis of structural design
NEN-EN 1991-1-4:	Eurocode 1: Actions on structures - Part 1-4: General actions – Wind actions
NEN7250:	Solar energy systems – Integration in roofs and facades – Constructional aspects
BS EN 1991-1-4:	British Standard

Type of solar panel

The ValkBox3 mounting system is a universal mounting system for solar panels. The following starting points apply:

Design panels:	Standard solar panels with an aluminium frame, with mounting holes for M6 bolts.
Length panels:	Up to max 2280 mm
Width panels:	926 - 1150 mm

Type of roofs

The ValkBox3 mounting system can be used to mount panels on flat roofs. The following starting points apply:

Type of roof covering: bitumen, EPDM and concrete



Before installing the ValkBox3 mounting system, make sure that you carefully sweep the roof area. The ValkBox3 mounting system (see later in this manual) may only be placed on flat roofs or ground surface up to a maximum pitch of 5 degrees. The system can not be placed on steeper roofs or surfaces.

Ballast

The ValkBox3 mounting system needs to be supported by ballast, to make sure that the system is unable to move, lift or tip over. This manual indicates how much ballast should be placed on the system based on maximum panel dimensions, wind area and roof height. The number of tiles specified (30 x 30 x 4.5 cm) per position will be vital to ensure that the mounting system can be used safely.



To achieve this, follow the required ballast instructions later in this manual.

Position

Restrictions also apply for the position of the system on a roof. The system must be installed at a certain distance from the edge of the roof, in the so called "middle zone".



According to the Eurocode for wind loads EN1991-1-4, the edge zone of the roof is 1/5th of the roof height. So for example: if the roof height is 6 meters, a free edge zone of 1,2 meters must be maintained.

Required ballast | Germany

General

The ValkBox3 mounting system must be ballasted by means of tiles, which must be placed on the indicated ballast foundations. In three steps you can easily determine the required ballast;

- Find the correct wind area for your location on the wind map
- Use the wind area in combination with the building height for the ballast table
- Select the required ballast for G1 and G2 in kg and/or number of tiles

Note 1: Min. extra ballast in G1 & G2 has to be 2 x 1 tile (2 x 9 kg).

Note 2: The ballast in G1 & G2 must be equally divided over the rubber ballast carriers.

Note 3: At maximum 17 tiles (30x30x4.5 cm) can be placed on the tile carriers. 4 tiles in G1 and 13 (2x6.5) tiles in G2. This represents a ballast weight of 153 kg).

Environmental factors

Roof zone

Terrain category

Height above sea level

Exclusief North German Lowland

Roofing materials

Middle zone

IV (city)

350 m

Bitumen, EPDM
or concrete

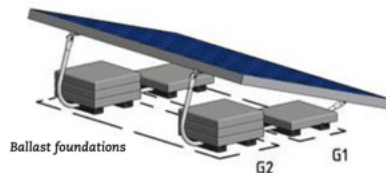

Windmap Germany

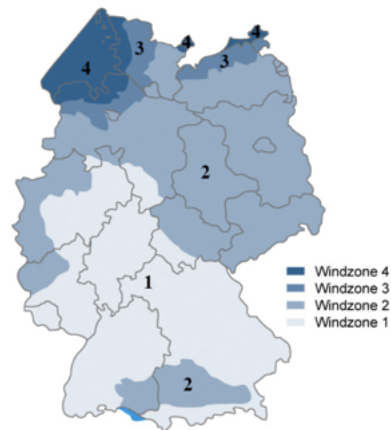

Panel: maximum dimensions 1800x1150 mm

Building height	0 - 5 meter		5 - 7 meter		7 - 9 meter		9 - 12 meter		12 - 15 meter		
	G1	G2	G1	G2	G1	G2	G1	G2	G1	G2	
1 (22,5 m/s)	36	41	36	41	36	41	36	41	36	41	kg
	4	5	4	5	4	5	4	5	4	5	tiles
2 (25 m/s)	36	56	36	56	36	56	36	56	36	56	kg
	4	6,5	4	6,5	4	6,5	4	6,5	4	6,5	tiles
3 (27,5 m/s)	36	72	36	72	36	72	36	72	36	72	kg
	4	8	4	8	4	8	4	8	4	8	tiles
4 (30 m/s)	36	89	36	89	36	89	36	89	36	89	kg
	4	10	4	10	4	10	4	10	4	10	tiles

Panel: maximum dimensions 2280x1150 mm

Building height	0 - 5 meter		5 - 7 meter		7 - 9 meter		9 - 12 meter		12 - 15 meter		
	G1	G2	G1	G2	G1	G2	G1	G2	G1	G2	
1 (22,5 m/s)	36	55	36	55	36	55	36	55	36	55	kg
	4	6,5	4	6,5	4	6,5	4	6,5	4	6,5	tiles
2 (25 m/s)	36	74	36	74	36	74	36	74	36	74	kg
	4	8,5	4	8,5	4	8,5	4	8,5	4	8,5	tiles
3 (27,5 m/s)	36	94	36	94	36	94	36	94	36	94	kg
	4	10,5	4	10,5	4	10,5	4	10,5	4	10,5	tiles
4 (30 m/s)	X	X	X	X	X	X	X	X	X	X	kg
	X	X	X	X	X	X	X	X	X	X	tiles

X = the required ballast is higher than will fit under the system. The system must be mechanically attached to the roof. Please contact Van der Valk Solar Systems.

* If you use tiles of different sizes and thus another weight, you need to adjust the number of tiles to get the right weight.

Components

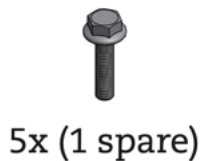
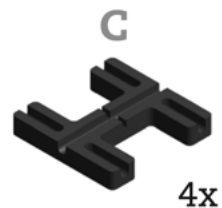
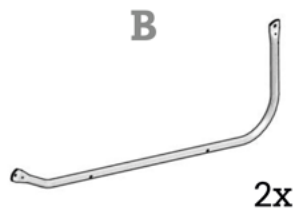
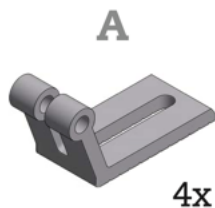

Step 1: Mounting the clevis

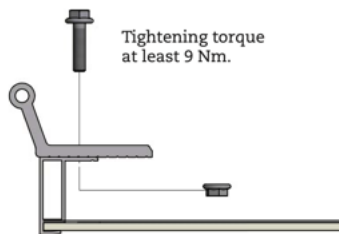
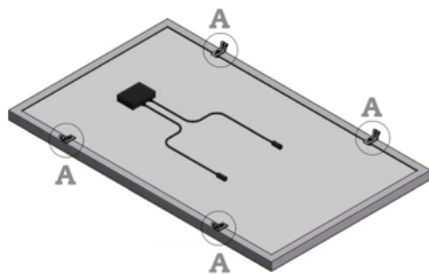

Step 2: Mounting the curved supports

The curved aluminum supports are suitable for panels with a width of 926 - 1150 mm.

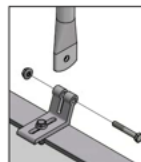
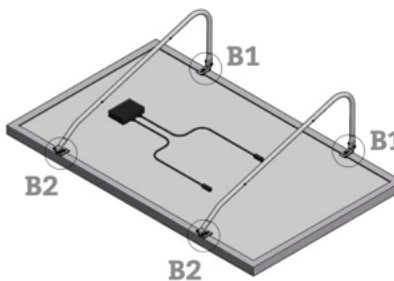

Depending on the panel width, the clamps B1 and B2 must be positioned inwards or outwards. The correct orientation for each panel width is shown on the next page.

Tighten the hinge bolts B1 by hand. These must be removed temporarily at step 4.

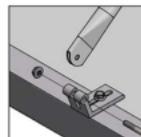

Tighten the hinge bolts B2 firmly, with a tightening torque of at least 9 Nm, until there is no more play.

Option 1: Mounting panel

For panel width 926 - 990 mm

Center to center mounting holes (panel frame): 896 - 970 mm

Under lip
turned inwards

C (1 : 4)



Top lip facing
inwards

D (1 : 4)



Option 2: Mounting panel

For panel width 991 - 1070 mm

Center to center mounting holes (panel frame): 970 - 1050 mm

Under lip
turned inwards

F (1 : 4)



Top lip facing
out

E (1 : 4)



Option 3: Mounting panel

For panel width 1071 - 1150 mm

Center to center mounting holes (panel frame): 1050 - 1124 mm

Under lip facing
outwards

A (1 : 4)



Top lip facing
out

B (1 : 4)



Step 3: Placing the rubber tiles

Turn over the panel and place it on the rubber tile carriers.

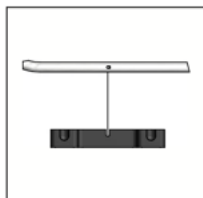
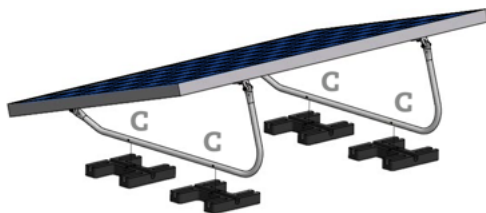

The projections on the curved aluminium supports must be placed in the grooves on the rubber tiles.

Step 4: Position the ballast

Remove the top hinge bolts B1 and place the panel in a vertical position. Make sure that you have some form of support in place or someone to hold the panel temporarily.

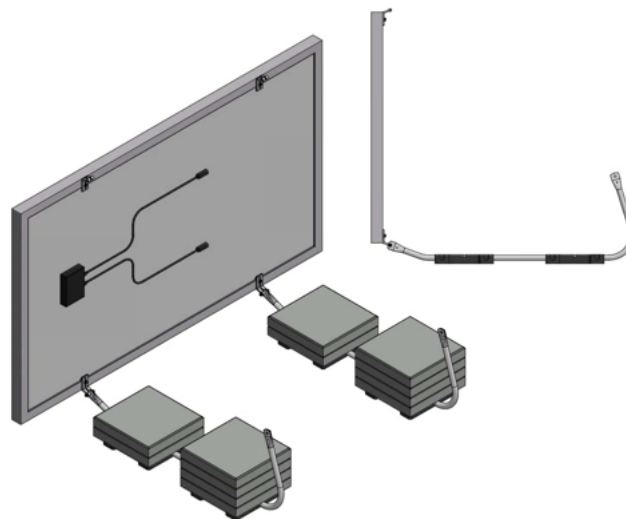

Position the ballast required.

Step 5: Tighten hinge bolts B1

Attach the panel to the curved supports again and tighten hinge bolts B1.

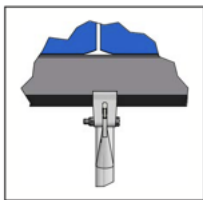
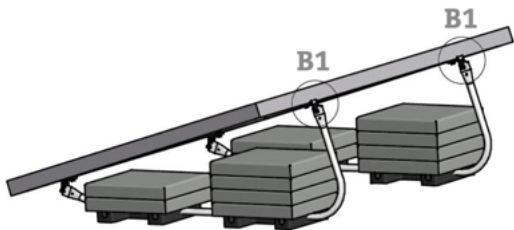

Tighten hinge bolts B1 tightly, with a tightening torque of at least 9 Nm, until there is no more play.

Step 6: Finish fitting the cables

The loose cables can be secured to the edge of the panel. Using the cable clamps supplied.

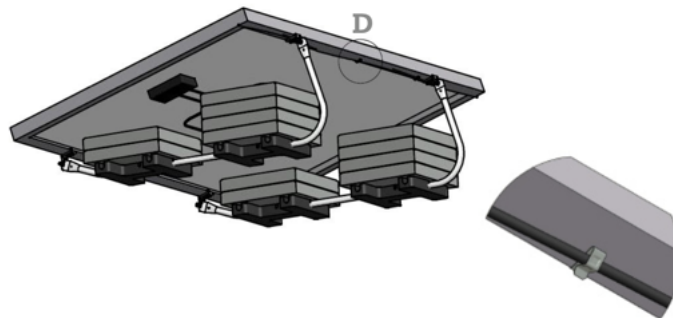

Step 7: Position the rows one behind each other

If a number of rows of panels are to be positioned one behind the other, we advise that an optimal pitch measure of 2.20 metres is observed; this will avoid any unwanted shadow. Optimal performance will be achieved if this pitch measure is used. Based on sun angle of 15 degrees.



