



IMPORTANT

Prior to installing Data Drive™, you must make sure to back up all your files so they can be transferred to your new hard drive. Data not backed up prior to new installation will be lost. Refer to http://manuals.playstation.net/document/en/ps4/settings/data_usb.html for the info and procedure for backing up data.

B SHEET

DATA BANK™

NYKO®

Enclosure Installation Procedure

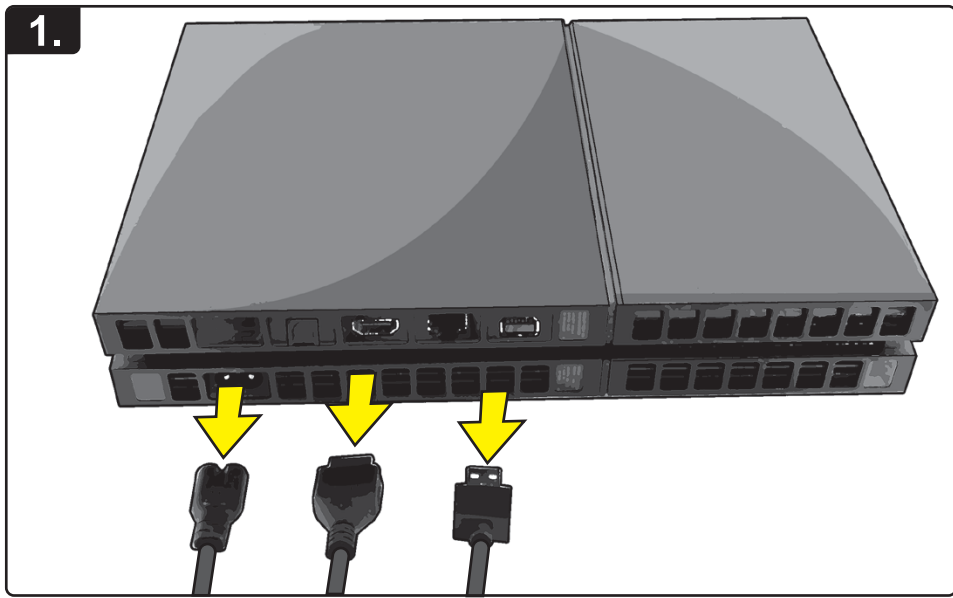

1. Turn off PS4 completely (not rest mode). Unplug all cables.

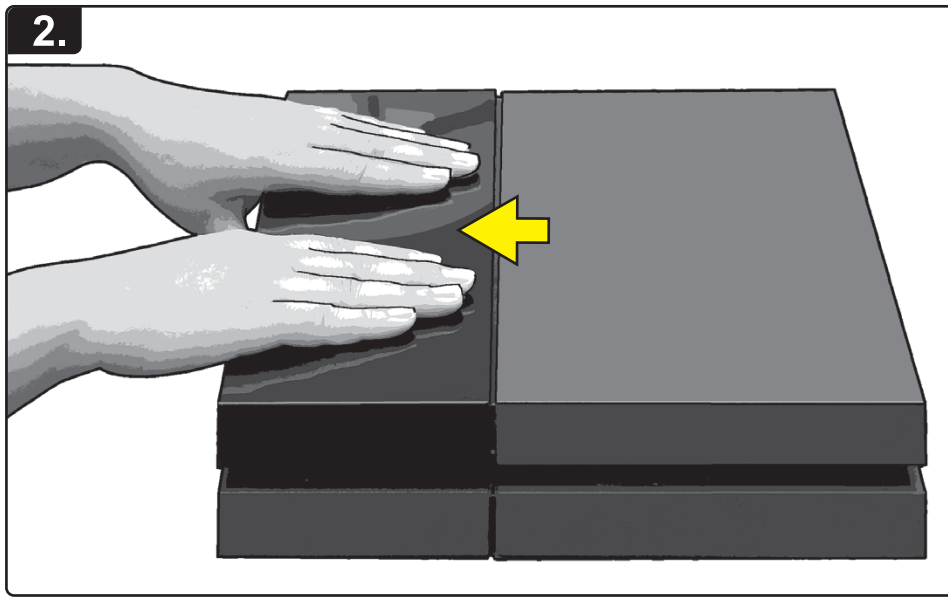

2. Gently slide off cover and store in a safe place for future use.

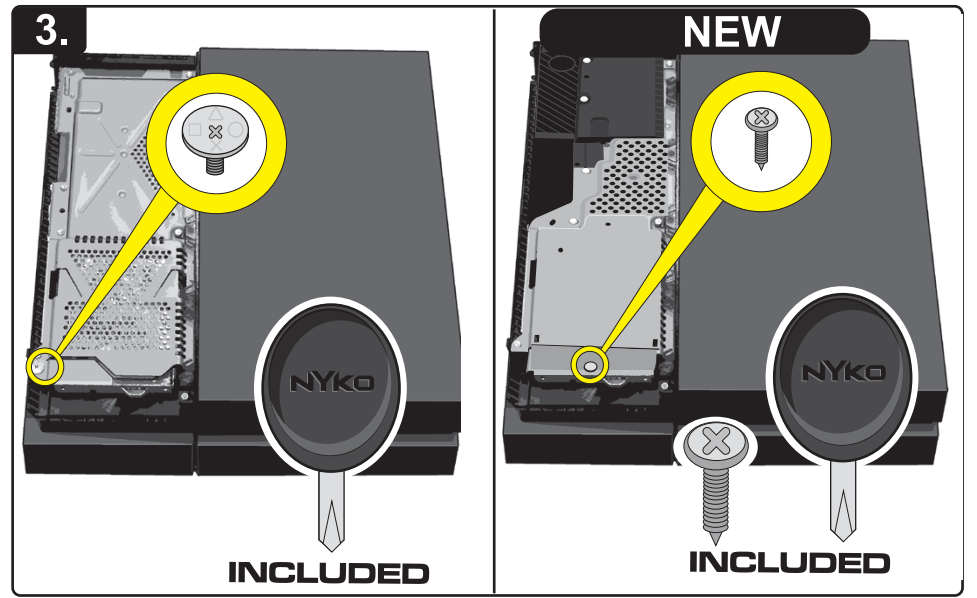

3. Use included screwdriver to remove the single screw

Use included screwdriver to remove the single screw of bottom left of the hard drive enclosure.

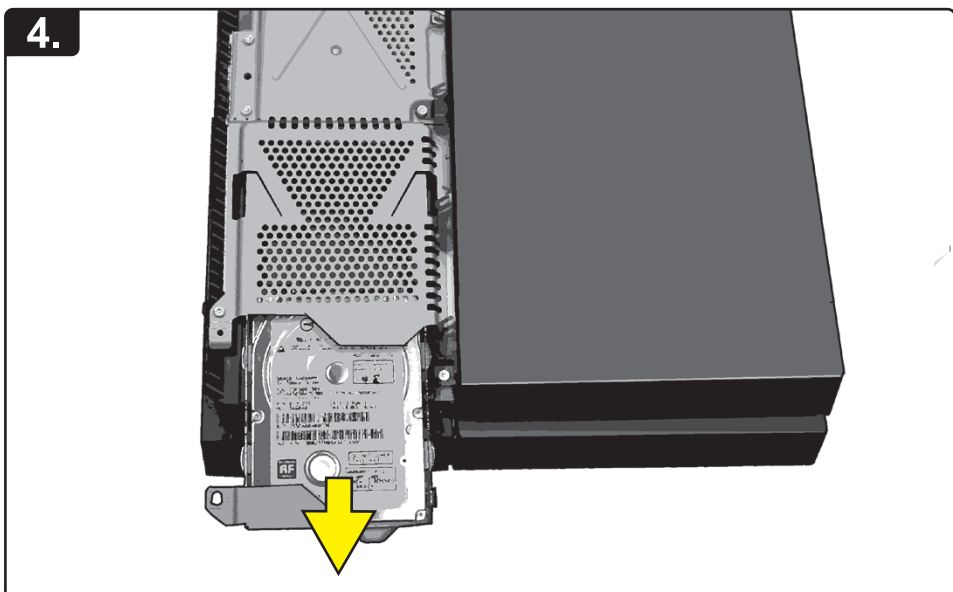

4. Once unscrewed, store screw in a safe place for later use. Slide hard drive tray out and store.

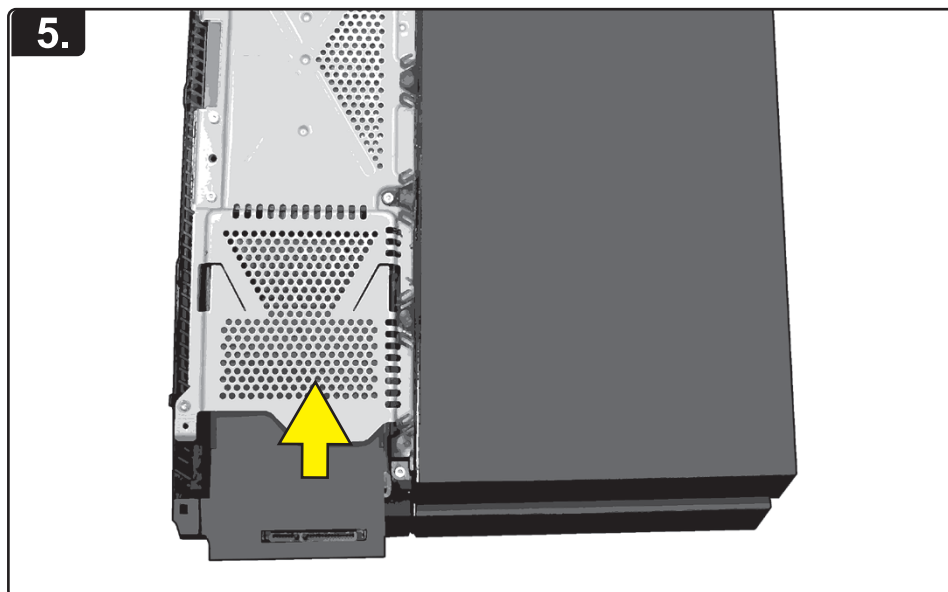

5. Insert the Data Bank's SATA Adaptor in place of the old HD.

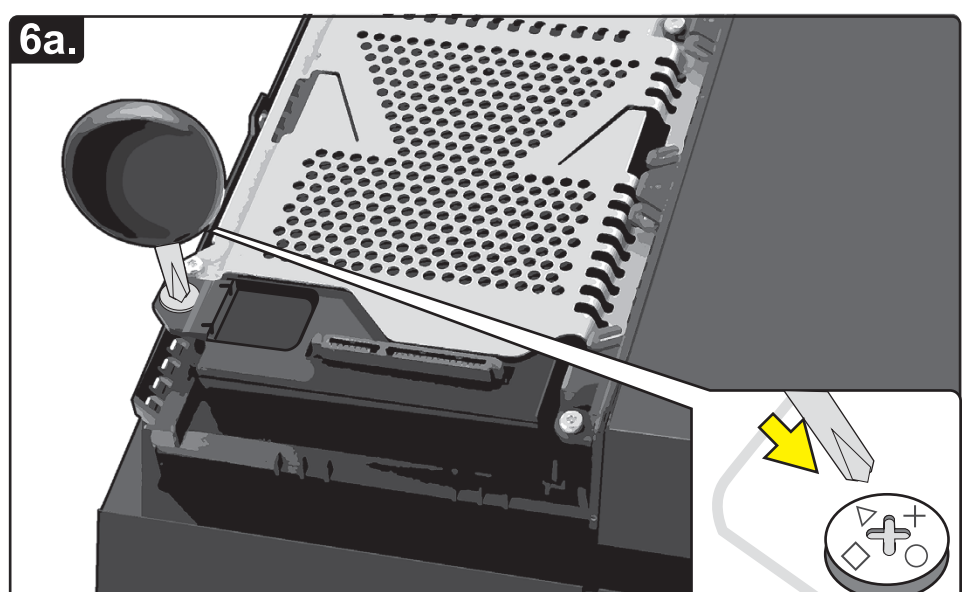

6a. Use the included screwdriver to secure the SATA adaptor in place with the screw you removed earlier.

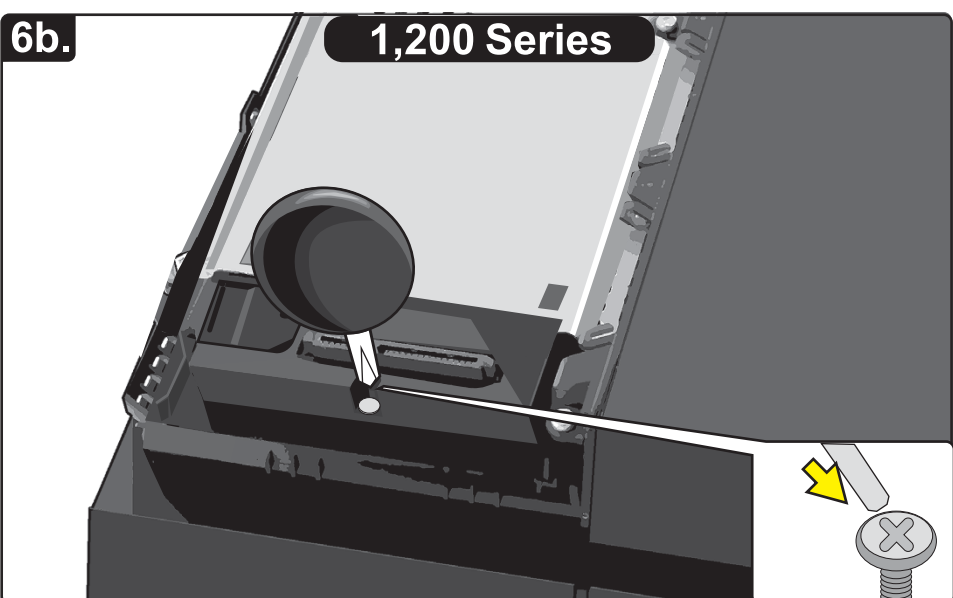

6b. Use the included screwdriver to secure the SATA adaptor in place with the provided screw.

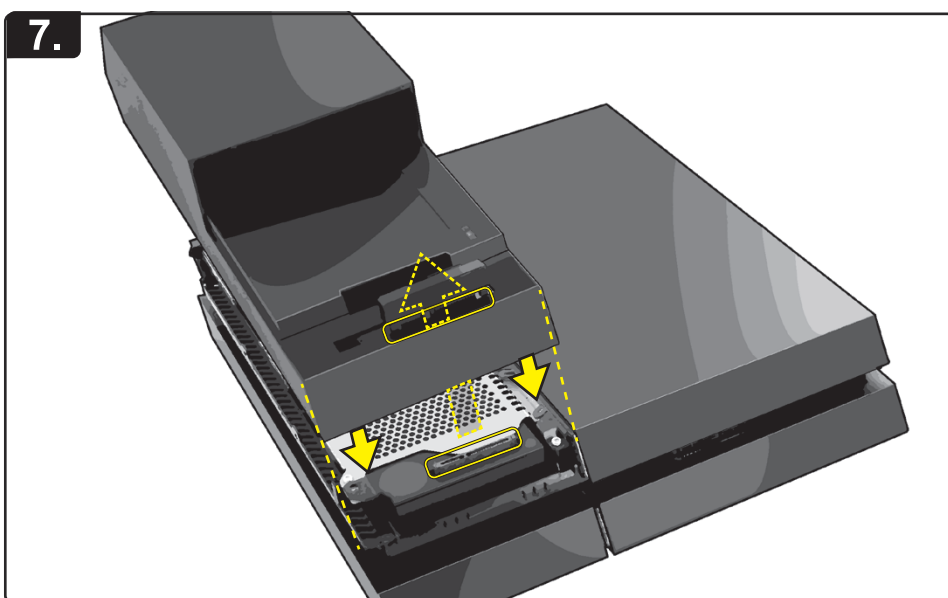

7. Gently lower the hood onto the PS4 making sure the connection port on the data adaptor goes through the hole.

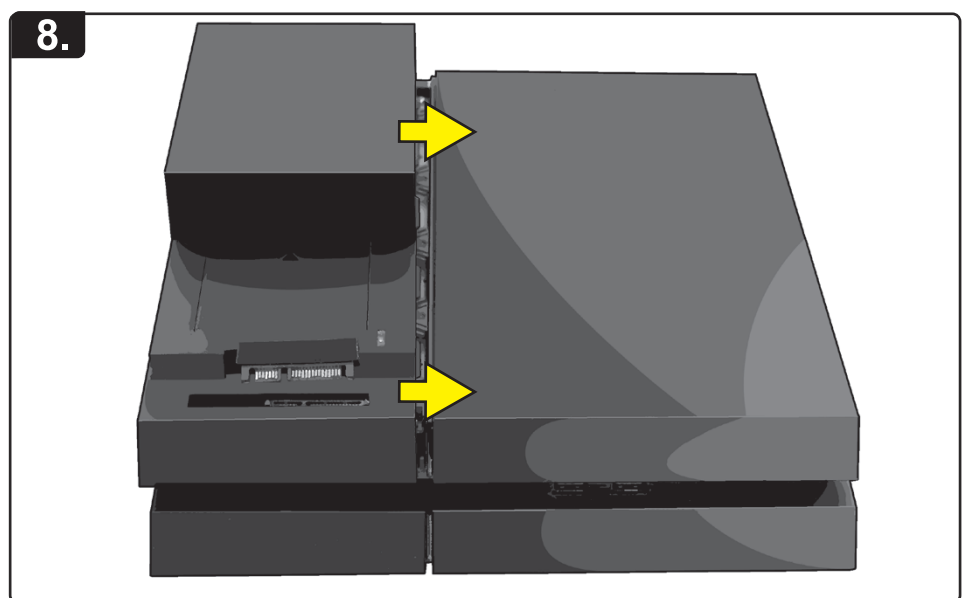

8. Slide hood gently to lock Data Bank cover into locked position.

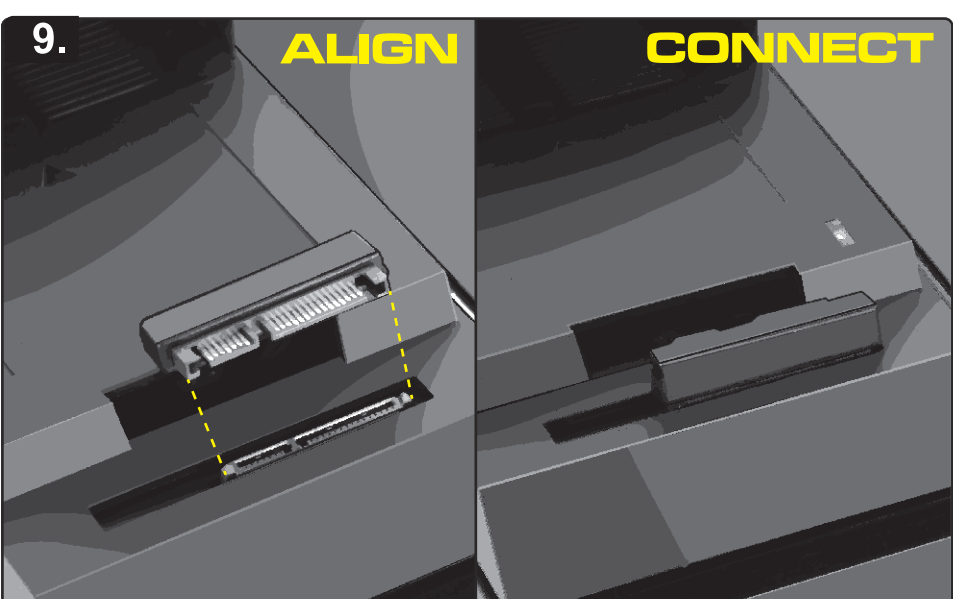

9. Align and connect the Data Bank cable to the exposed connection port on your SATA adaptor.

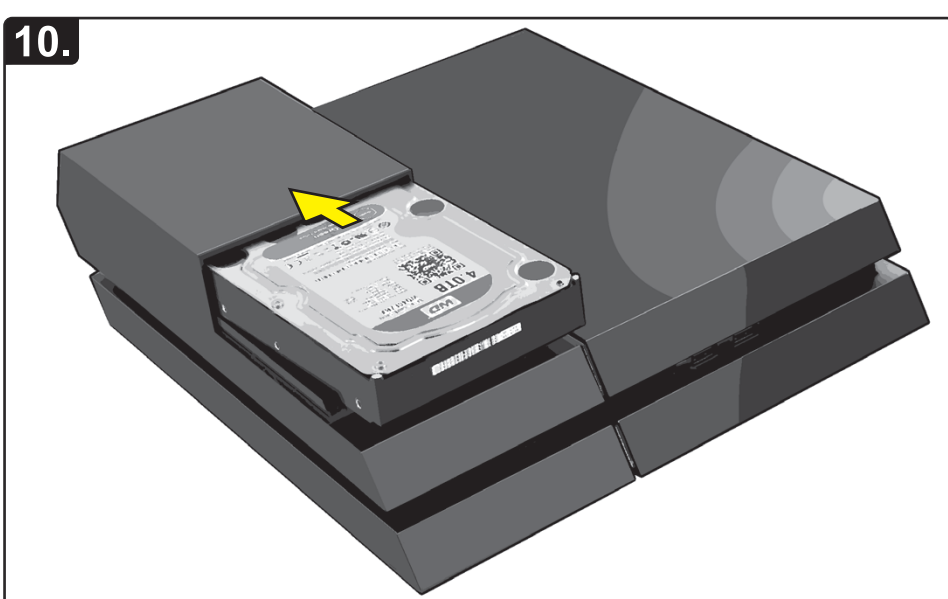

10. Gently slide a 3.5 hard drive (not included) into the port on the Data Bank.

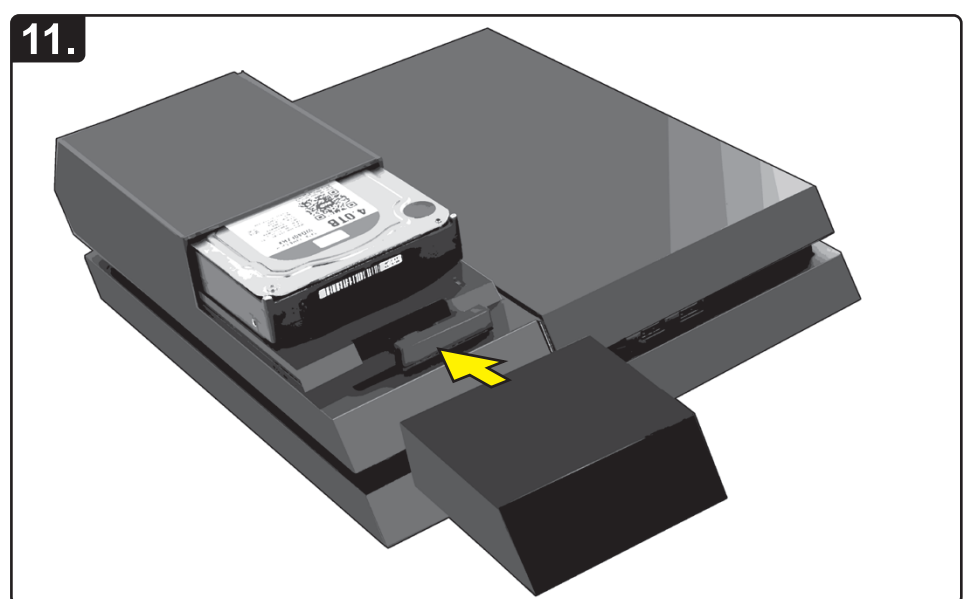

11. Gently cover the exposed HD by gliding the Data Bank hood onto the Data Bank.

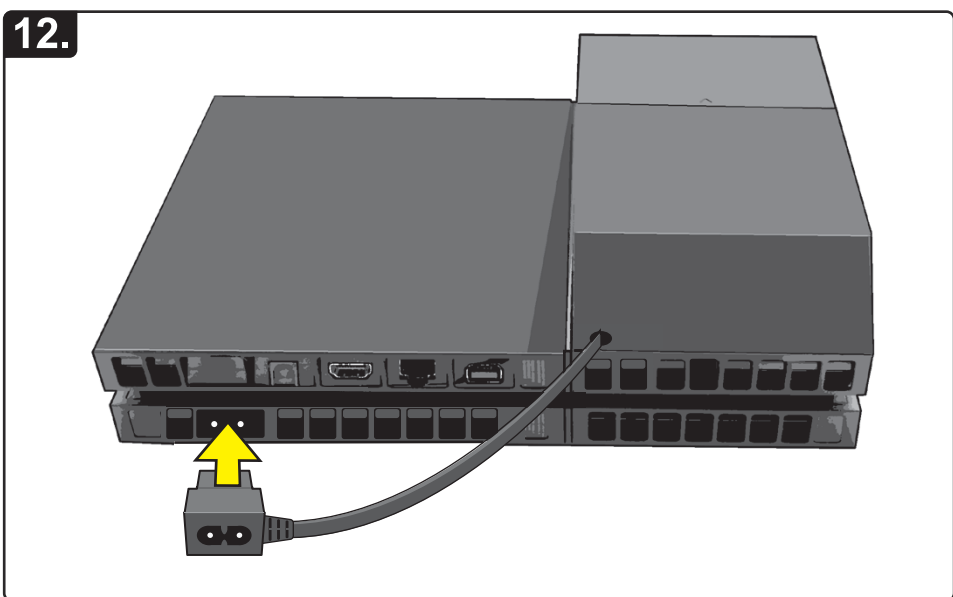

12. Once successfully installed, connect the Data Bank's power cable

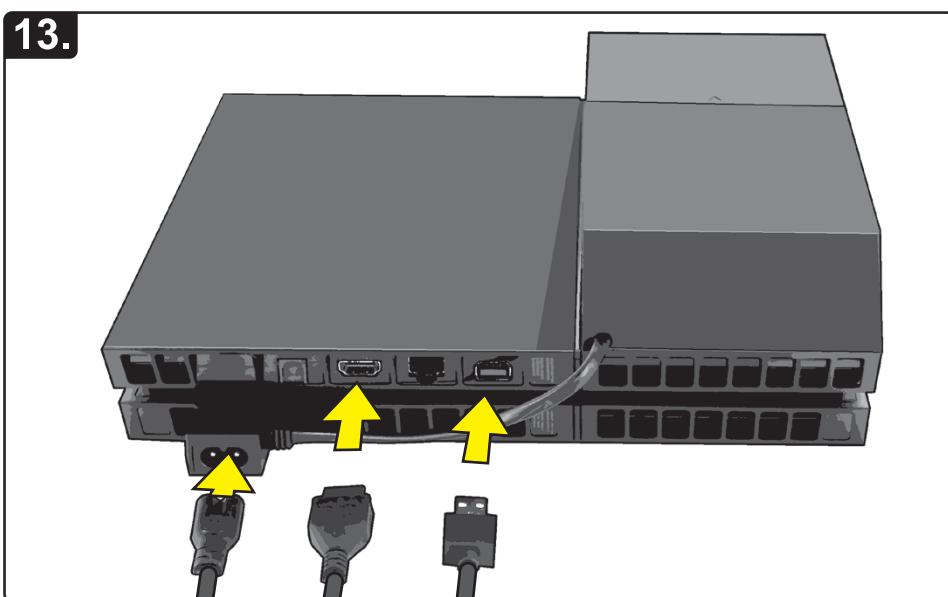

13. Reattach all cables.

NYKO®

Register this product online:
www.nyko.com

If you are experiencing difficulties, please contact us:
Email: customersupport@nyko.com
Phone: +1-888-400-6956

Nyko Product Limited Warranty:

This Nyko product is warranted to the original purchaser for the product's normal intended use for a period of ninety (90) days from the date of purchase. If a defect covered under this warranty occurs, Nyko will replace or repair the product or its defective parts, at Nyko's option, at no charge. This warranty does not apply to defects resulting from misuse or modification of the product. The product should be returned with proof of purchase, a brief statement of the claimed defect, and the purchaser's contact information, to: Nyko Technologies, Inc., 1990 Westwood Blvd., 3rd Floor, Los Angeles, CA 90025, with freight charges prepaid. Please allow 3-4 weeks for processing.