

THERMOFLOC[®]

Intelligent Insulation System



FLOOR INSULATION

Reduce energy costs and improve the indoor environment.

Outstanding natural loose-fill insulation!

Loose-fill insulation is an insulating material which is loosely poured or compacted. It is used mainly for heat and sound insulation in wooden beam ceilings, under screed slabs or for filling hard-to-reach cavities with insulation that is or is not resistant to compression.

THERMOFLOC offers two product versions as a loose-fill insulating material. On the one hand, THERMOFLOC floor filling as a cellulose insulation that is not resistant to compression and on the other hand, THERMOFLOC insulation pellets as cellulose granules that are resistant to compression.



THERMOFLOC floor filling
as cellulose insulation not resistant to compression



THERMOFLOC insulation pellets
as cellulose granules resistant to compression



BORATE-FREE FLOOR FILLING



THERMOFLOC floor filling – the do-it-yourself version of insulation

For decades, companies employing specially trained staff to operate blowing machines have been successfully using loose insulating materials made from cellulose fibres to insulate walls, floors, ceilings and roofs.

Peter Seppel Gesellschaft m.b.H. has now obtained a European Technical Assessment (ETA) for the manual processing of THERMOFLOC floor filling so that floors and ceilings can be insulated without the use of blowing machines. This means that now the top floor ceiling and floors can also be insulated manually between the beams of the structure using insulation that is not resistant to compression, without sacrificing the advantages of joint-free thermal insulation. As a result, the advantages of loose insulation made from cellulose fibres can also be brought to bear using the manual process.

Easy to handle and calculate accurately!

Floor insulation made easy!

THERMOFLOC floor filling is not only easy to handle but also ingenious. This version of floor filling does not have to be laboriously cut to size first, as the desired insulation thickness is simply tipped in manually and then levelled off flat. So there's no waste. Furthermore, it's possible to calculate the material required in advance.

Consumption is approximately 35 kg/m³.

Dämmstärke	offen auf Betondecke 160 mm	Balkenlage mit 11 % Balkenanteil, Heraklith 35 mm und Putz 15 mm	Materialverbrauch kg/m ²
100 mm	0,35 W/(m ² K)	0,36 W/(m ² K)	3
120 mm	0,29 W/(m ² K)	0,31 W/(m ² K)	3,6
140 mm	0,25 W/(m ² K)	0,27 W/(m ² K)	4,2
160 mm	0,22 W/(m ² K)	0,25 W/(m ² K)	4,8
180 mm	0,20 W/(m ² K)	0,22 W/(m ² K)	5,4
200 mm	0,18 W/(m ² K)	0,20 W/(m ² K)	7
220 mm	0,17 W/(m ² K)	0,18 W/(m ² K)	7,7
240 mm	0,15 W/(m ² K)	0,17 W/(m ² K)	8,4
260 mm	0,14 W/(m ² K)	0,16 W/(m ² K)	9,1
280 mm		0,14 W/(m ² K)	9,8



A tub, a drill, a paint stirrer and a rake are required to process the THERMOFLOC floor filling.

The compressed insulating material is broken up into coarse pieces and placed in the tub.



The insulating material is loosened up using a drill and a paint stirrer until a loose fluffy filling is formed. The insulating material is then tipped into the structure and spread out evenly without gaps throughout the structure using a rake.





BORATE-FREE FLOOR FILLING

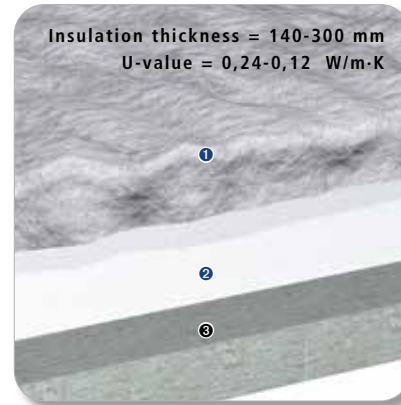
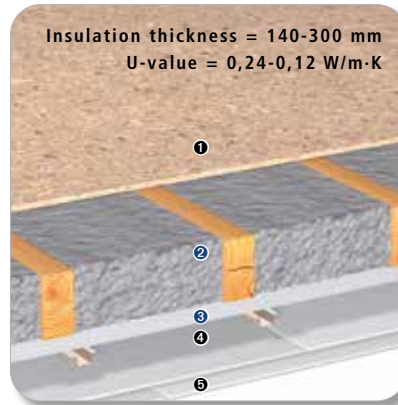
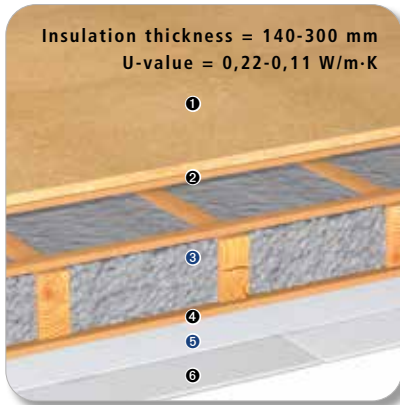

Floor construction DB1

Tie-beam insulation

- ① Wood wool panel
- ② Subfloor/unfinished floor
- ③ Tie-beam/THERMOFLOC floor filling
- ④ Battening
- ⑤ THERMOFLOC vapour-proof lining
- ⑥ Plasterboard

Floor construction DB3

Ceiling

- ① OSB/plywood
- ② Beam/THERMOFLOC floor filling
- ③ THERMOFLOC vapour-proof lining
- ④ Spring rails
- ⑤ Plasterboards 2-layer

Insulation

Top storey ceiling

- ① Beam/THERMOFLOC floor filling
- ② THERMOFLOC vapour-proof lining
- ③ Concrete ceiling

Technical details	Composition	Newspaper fibres, additives <10%
	Approvals / certificates	ETA - 18/0816
	Installation thickness	33 - 48 kg/m ³
	Fire behaviour	Class E ≥ 40 mm
	Resistance to mould growth	Class 0
	Sound absorption	$\alpha_w = 1,00 / d \geq 100 \text{ mm}$
	Rated value of thermal conductivity	$\lambda_{D(23,50)} = 0,038 \text{ W/m}\cdot\text{K}$
	Design value of thermal conductivity	$\lambda_B = 0,040 \text{ W/m}\cdot\text{K}$
	Water vapour diffusion resistance DIN EN ISO 10456	$\mu \leq 2$
	Metal corrosion	Class CR
Settling	$S_v = 7,0 \% / 33,4 \text{ kg/m}^3$ $S_{cyc} = 22,9 \% / \text{Class SH 25}$	
Water absorption	$W_p = 26,79 \text{ kg/m}^2 / 45 \text{ kg/m}^3$	

Insulation pellets as a load-bearing floor structure

THERMOFLOC insulation pellets are used as floor filling. The granules are simply poured in to the desired installation depth and then levelled off flat. This means that subfloor structures with an installation height of 30 to 80 mm can be produced quickly.

Due to their high bulk density, they are ideally suited as a load-bearing insulation layer. With THERMOFLOC insulation pellets, you also achieve excellent sound insulation values.

It's also possible to accurately calculate the material required in advance. A filling depth of 40 mm requires 40 l per m². Our THERMOFLOC insulation pellets are available in 40 l bags, with 36 bags to a pallet.

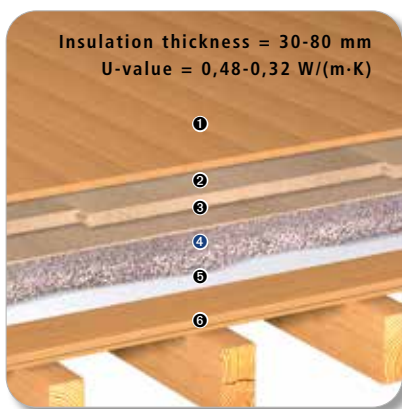

Floor construction DB7

Ceiling

- ① Wooden floorboards
- ② Soft fibre N+F
- ③ Soft fibre cover panel
- ④ THERMOFLOC insulation pellets
- ⑤ Trickle protection
- ⑥ Fire-resistant panelling

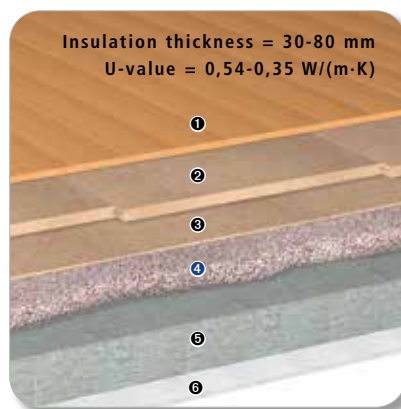

Floor construction DB14

Ceiling

- ① Wooden floorboards
- ② Soft fibre N+F
- ③ Soft fibre cover panel
- ④ THERMOFLOC insulation pellets
- ⑤ Concrete ceiling
- ⑥ Ceiling plaster

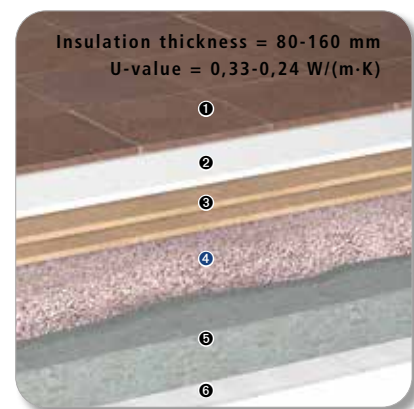

Floor construction DB15

Ceiling

- ① Ceramic tiles
- ② Gypsum plasterboard
- ③ Soft wood fibreboard
- ④ THERMOFLOC insulation pellets
- ⑤ Concrete ceiling
- ⑥ Ceiling plaster



INSULATION PELLETS



Flexible-use insulation pellets

Whether concrete ceiling or timber beam ceiling, THERMOFLOC insulation pellets can significantly improve the insulating properties of both types of construction. Insulation pellets can also be used as a levelling fill or as a base for dry screeds.

Technical details	Rated value of thermal conductivity	$\lambda_{D(23/50)} = \lambda_D = 0,108 \text{ W/m}\cdot\text{K}$
	Construction material class	E
	Bulk density (mean value)	$P_b = 455 \text{ kg/m}^3$
	Dynamic stiffness, nominal thickness 50 mm (mean value)	$s' = 52 \text{ MN/m}^3$
	Dynamic stiffness, nominal thickness 80 mm (mean value)	$s' = 32 \text{ MN/m}^3$
	Compressibility for a pour thickness of 80 mm	$c = 5 \text{ mm}$
	Impact sound reduction for cement screed	$\Delta L_w = 19,8 - 25,2 \text{ dB}$
	Impact sound reduction for dry screed	$\Delta L_w = 15,9 - 20,2 \text{ dB}$
Water vapour diffusion resistance	$\mu = 2,7$	

Non-crushable and soundproof!

THERMOFLOC®

Intelligent Insulation System

FLOOR FILLING



INSULATION PELLETS



EN

THERMOFLOC-Partner:

[Empty dashed box for partner information]

Peter Seppel Gesellschaft m.b.H.

Bahnhofstraße 79 | A-9710 Feistritz/Drau | Tel.: +43 4245 6201 | Fax: +43 4245 6336