



**WACKER
NEUSON**

Operator's Manual

Dumpers

DW60

DW90

DW100



Machine type	D18-01/D18-02/D18-03
Edition	1.1
Order no	5100015363
Language	us



5 1 0 0 0 1 5 3 6 3

Documentation	Language	Order no.	Documentation	Language	Order no.
Operator's manual	us	5100015363			
Spare parts list	DW 60 [de en fr]	1000333050	Spare parts list	DW 100 [de en fr]	1000333064
	DW 60 [it es en]	1000333061		DW 100 [it es en]	1000333065
	DW 90 [de en fr]	1000333062			
	DW 90 [it es en]	1000333063			

Legend

Original Operator's Manual	x
Translation of original Operator's Manual	–
Edition	1.1
Date	02/2016
Document	BA D18 us*

Copyright © 2014 Wacker Neuson Linz GmbH, Hörsching

Printed in Austria

All rights reserved, in particular the copyright, the right of reproduction and the right of distribution applicable worldwide.

No part of this publication may be reproduced, translated or used in any form or by any means – graphic, electronic or mechanical including photocopying, recording, taping or information storage or retrieval systems – without prior permission in writing from the manufacturer.

No reproduction or translation of this publication, in whole or part, without the written consent of Wacker Neuson Linz GmbH.

Violations of legal regulations, in particular of the copyright protection, will be subject to civil and criminal prosecution.

Wacker Neuson Linz GmbH keep abreast of the latest technical developments and constantly improve their products. For this reason, we may from time to time need to make changes to figures and descriptions in this documentation which do not reflect products that have already been delivered and that will not be implemented on these machines.

Technical data, dimensions and weights are only given as an indication. Non-metric weights and measurements are approximate. Responsibility for errors or omissions not accepted.

The cover features the machine with possible optional equipment.

Photographs and graphics are symbolic representations and may differ from the actual products.

Wacker Neuson is authorized to reprint the copyright-protected material of Perkins Engines Company Ltd contained in this document. Translation of original Operator's Manual.

The Operator's Manual and any amendments to it must always be available at the place of use of the machine. Possible amendments are included at the end of the Operator's Manual.



Wacker Neuson Linz GmbH

Flughafenstr. 7

A-4063 Hörsching

Phone: +43 (0) 7221 63000

Fax: +43 (0) 7221 63000-2200

E-mail: office.linz@wackerneuson.com

www.wackerneuson.com

Table of contents

1 Foreword	
1.1 Operator's Manual	1-1
1.2 Warranty and liability	1-7
2 Safety	
2.1 Safety symbols and signal words	2-1
2.2 Qualification of operating personnel	2-2
2.3 Conduct	2-3
2.4 Operation	2-4
2.5 Lifting gear applications	2-8
2.6 Trailer operation	2-10
2.7 Attachment operation	2-10
2.8 Towing, loading and transporting	2-11
2.9 Maintenance	2-13
2.10 Measures for avoiding risks	2-17
3 Introduction	
3.1 Machine overview	3-1
3.2 Brief description of machine	3-3
3.3 Information and regulations on use	3-4
3.4 Labels	3-5
4 Putting into operation	
4.1 Cabin/control stand	4-1
4.2 Overview of control elements	4-17
4.3 Indicator lights and warning lights (overview)	4-24
4.4 Preparatory work	4-29
4.5 Starting and stopping the engine	4-34
5 Operation	
5.1 Steering system	5-2
5.2 Accelerator actuation	5-3
5.3 Brakes	5-4
5.4 Machine travel	5-9
5.5 Differential lock	5-15
5.6 Lights/signaling system	5-16
5.7 Wiper/wash system (option)	5-20
5.8 Heating, ventilation and air conditioning system	5-21
5.9 Operating hydraulics	5-22
5.10 Attachments	5-24
5.11 Work operation	5-24
5.12 Emergency lowering	5-29
5.13 Options	5-29
5.14 Putting out of operation/back into operation	5-32
5.15 Permanently putting out of operation	5-34
6 Transportation	
6.1 Towing the machine	6-1
6.2 Loading the machine	6-5
6.3 Transporting the machine	6-9

7	Maintenance	
7.1	Information on maintenance	7-1
7.2	Maintenance overview	7-2
7.3	Fluids and lubricants	7-10
7.4	Maintenance accesses	7-13
7.5	Cleaning and maintenance	7-16
7.6	Lubrication work.....	7-19
7.7	Fuel system	7-19
7.8	Engine lubrication system.....	7-25
7.9	Cooling system	7-28
7.10	Air filter.....	7-32
7.11	V-belt	7-33
7.12	Hydraulic system	7-33
7.13	Electrical system.....	7-37
7.14	Heating, ventilation and air conditioning system.....	7-39
7.15	Washer system	7-39
7.16	Axles	7-39
7.17	Braking system	7-39
7.18	Tires.....	7-40
7.19	Maintenance of attachments.....	7-41
7.20	Maintenance of options.....	7-41
7.21	Exhaust gas treatment.....	7-42
7.22	Machine preservation	7-48
8	Malfunctions	
8.1	Engine warning lights.....	8-1
8.2	Engine and engine oil indicator lights	8-2
8.3	Malfunctions (display element/multifunctional display)	8-2
8.4	General malfunctions.....	8-4
9	Technical data	
9.1	Model designations and trade names.....	9-1
9.2	Engine.....	9-1
9.3	Traveling drive/axles	9-2
9.4	Brakes.....	9-3
9.5	Tires.....	9-4
9.6	Steering system	9-4
9.7	Operating hydraulics	9-4
9.8	Electrical system	9-5
9.9	Tightening torques	9-9
9.10	Coolant	9-10
9.11	Noise emissions.....	9-10
9.12	Vibration.....	9-11
9.13	Weight.....	9-14
9.14	Payload.....	9-15
9.15	Dimensions	9-16
	Index	
	Index	S-1

EC Declaration of Conformity**Manufacturer**

Wacker Neuson Linz GmbH, Flughafenstr. 7, 4063 Hörsching, Austria

**Product**

Machine designation	Compact Dumper
Model/version	D18-01
Trade name	DW60
Serial number	--
Output in kW	55
Measured sound power level dB(A)	101
Guaranteed sound power level dB(A)	101

Declaration of conformity

Notified body according to Directive 2006/42/EC, appendix XI:
DGUV Test-, Prüf- und Zertifizierungsstelle
Fachausschuss Bauwesen, Landsberger Str. 309, 80687 Munich, Germany
Distinguishing EU number 0515

Notified body involved in procedure

TÜV SÜD Industrie Service GmbH
Westendstr. 199
D-80686 Munich

Directives and standards

We hereby declare that this product corresponds to the relevant regulations of the following Directives and standards:
2006/42/EC, 2004/108/EC, 2005/88/EC, 2000/14/EC;
DIN EN ISO 12100:2010, DIN EN 474-1:2006+A1:2009, DIN EN 474-6:2010, DIN EN ISO 3471:2010

Authorized representative for the compilation of technical documentation

Thomas Köck, team leader technical documentation
Flughafenstr. 7
4063 Hörsching
Austria

Johannes Mahringer,
Managing director

The indications specified above correspond to the existing information at time of going to press. They have possibly changed in the meantime (refer to the original declaration of conformity supplied with the machine). Applies to EU countries, and countries with legislation similar to that of the EU. Applies to all machines with CE marks that have not been modified without authorization since the product was placed on the market.

EC Declaration of Conformity

Manufacturer

Wacker Neuson Linz GmbH, Flughafenstr. 7, 4063 Hörsching, Austria

**Product**

Machine designation	Compact Dumper
Model/version	D18-01
Trade name	DW60
Serial number	--
Output in kW	86
Measured sound power level dB(A)	101
Guaranteed sound power level dB(A)	103

Declaration of conformity

Notified body according to Directive 2006/42/EC, appendix XI:
 DGUV Test-, Prüf- und Zertifizierungsstelle
 Fachausschuss Bauwesen, Landsberger Str. 309, 80687 Munich, Germany
 Distinguishing EU number 0515

Notified body involved in procedure

TÜV SÜD Industrie Service GmbH
 Westendstr. 199
 D-80686 Munich

Directives and standards

We hereby declare that this product corresponds to the relevant regulations of the following Directives and standards:
 2006/42/EC, 2004/108/EC, 2005/88/EC, 2000/14/EC;
 DIN EN ISO 12100:2010, DIN EN 474-1:2006+A1:2009, DIN EN 474-6:2010, DIN EN ISO 3471:2010

Authorized representative for the compilation of technical documentation

Thomas Köck, team leader technical documentation
 Flughafenstr. 7
 4063 Hörsching
 Austria

 Johannes Mahringer,
 Managing director

The indications specified above correspond to the existing information at time of going to press. They have possibly changed in the meantime (refer to the original declaration of conformity supplied with the machine). Applies to EU countries, and countries with legislation similar to that of the EU. Applies to all machines with CE marks that have not been modified without authorization since the product was placed on the market.

EC Declaration of Conformity**Manufacturer**

Wacker Neuson Linz GmbH, Flughafenstr. 7, 4063 Hörsching, Austria

**Product**

Machine designation	Compact Dumper
Model/version	D18-02
Trade name	DW90
Serial number	--
Output in kW	55
Measured sound power level dB(A)	99
Guaranteed sound power level dB(A)	99

Declaration of conformity

Notified body according to Directive 2006/42/EC, appendix XI:
DGUV Test-, Prüf- und Zertifizierungsstelle
Fachausschuss Bauwesen, Landsberger Str. 309, 80687 Munich, Germany
Distinguishing EU number 0515

Notified body involved in procedure

TÜV SÜD Industrie Service GmbH
Westendstr. 199
D-80686 Munich

Directives and standards

We hereby declare that this product corresponds to the relevant regulations of the following Directives and standards:
2006/42/EC, 2004/108/EC, 2005/88/EC, 2000/14/EC;
DIN EN ISO 12100:2010, DIN EN 474-1:2006+A1:2009, DIN EN 474-6:2010, DIN EN ISO 3471:2010

Authorized representative for the compilation of technical documentation

Thomas Köck, team leader technical documentation
Flughafenstr. 7
4063 Hörsching
Austria

Johannes Mahringer,
Managing director

The indications specified above correspond to the existing information at time of going to press. They have possibly changed in the meantime (refer to the original declaration of conformity supplied with the machine). Applies to EU countries, and countries with legislation similar to that of the EU. Applies to all machines with CE marks that have not been modified without authorization since the product was placed on the market.

EC Declaration of Conformity

Manufacturer

Wacker Neuson Linz GmbH, Flughafenstr. 7, 4063 Hörsching, Austria

**Product**

Machine designation	Compact Dumper
Model/version	D18-02
Trade name	DW90
Serial number	--
Output in kW	86
Measured sound power level dB(A)	103
Guaranteed sound power level dB(A)	103

Declaration of conformity

Notified body according to Directive 2006/42/EC, appendix XI:
 DGUV Test-, Prüf- und Zertifizierungsstelle
 Fachausschuss Bauwesen, Landsberger Str. 309, 80687 Munich, Germany
 Distinguishing EU number 0515

Notified body involved in procedure

TÜV SÜD Industrie Service GmbH
 Westendstr. 199
 D-80686 Munich

Directives and standards

We hereby declare that this product corresponds to the relevant regulations of the following Directives and standards:
 2006/42/EC, 2004/108/EC, 2005/88/EC, 2000/14/EC;
 DIN EN ISO 12100:2010, DIN EN 474-1:2006+A1:2009, DIN EN 474-6:2010, DIN EN ISO 3471:2010

Authorized representative for the compilation of technical documentation

Thomas Köck, team leader technical documentation
 Flughafenstr. 7
 4063 Hörsching
 Austria

 Johannes Mahringer,
 Managing director

The indications specified above correspond to the existing information at time of going to press. They have possibly changed in the meantime (refer to the original declaration of conformity supplied with the machine). Applies to EU countries, and countries with legislation similar to that of the EU. Applies to all machines with CE marks that have not been modified without authorization since the product was placed on the market.

EC Declaration of Conformity**Manufacturer**

Wacker Neuson Linz GmbH, Flughafenstr. 7, 4063 Horsching, Austria

**Product**

Machine designation	Compact Dumper
Model/version	D18-03
Trade name	DW100
Serial number	--
Output in kW	55
Measured sound power level dB(A)	99
Guaranteed sound power level dB(A)	99

Declaration of conformity

Notified body according to Directive 2006/42/EC, appendix XI:
DGUV Test-, Prüf- und Zertifizierungsstelle
Fachausschuss Bauwesen, Landsberger Str. 309, 80687 Munich, Germany
Distinguishing EU number 0515

Notified body involved in procedure

TÜV SÜD Industrie Service GmbH
Westendstr. 199
D-80686 Munich

Directives and standards

We hereby declare that this product corresponds to the relevant regulations of the following Directives and standards:
2006/42/EC, 2004/108/EC, 2005/88/EC, 2000/14/EC;
DIN EN ISO 12100:2010, DIN EN 474-1:2006+A1:2009, DIN EN 474-6:2010, DIN EN ISO 3471:2010

Authorized representative for the compilation of technical documentation

Thomas Köck, team leader technical documentation
Flughafenstr. 7
4063 Horsching
Austria

Johannes Mahringer,
Managing director

The indications specified above correspond to the existing information at time of going to press. They have possibly changed in the meantime (refer to the original declaration of conformity supplied with the machine). Applies to EU countries, and countries with legislation similar to that of the EU. Applies to all machines with CE marks that have not been modified without authorization since the product was placed on the market.

EC Declaration of Conformity

Manufacturer

Wacker Neuson Linz GmbH, Flughafenstr. 7, 4063 Hörsching, Austria

**Product**

Machine designation	Compact Dumper
Model/version	D18-03
Trade name	DW100
Serial number	--
Output in kW	86
Measured sound power level dB(A)	103
Guaranteed sound power level dB(A)	103

Declaration of conformity

Notified body according to Directive 2006/42/EC, appendix XI:
 DGUV Test-, Prüf- und Zertifizierungsstelle
 Fachausschuss Bauwesen, Landsberger Str. 309, 80687 Munich, Germany
 Distinguishing EU number 0515

Notified body involved in procedure

TÜV SÜD Industrie Service GmbH
 Westendstr. 199
 D-80686 Munich

Directives and standards

We hereby declare that this product corresponds to the relevant regulations of the following Directives and standards:
 2006/42/EC, 2004/108/EC, 2005/88/EC, 2000/14/EC;
 DIN EN ISO 12100:2010, DIN EN 474-1:2006+A1:2009, DIN EN 474-6:2010, DIN EN ISO 3471:2010

Authorized representative for the compilation of technical documentation

Thomas Köck, team leader technical documentation
 Flughafenstr. 7
 4063 Hörsching
 Austria

 Johannes Mahringer,
 Managing director

The indications specified above correspond to the existing information at time of going to press. They have possibly changed in the meantime (refer to the original declaration of conformity supplied with the machine). Applies to EU countries, and countries with legislation similar to that of the EU. Applies to all machines with CE marks that have not been modified without authorization since the product was placed on the market.

1 Foreword

1.1 Operator's Manual

Information on this Operator's Manual

The Operator's Manual is stored in the document box under the seat.

This Operator's Manual contains important information on how to work safely, correctly and economically with the machine. Therefore, it aims not only at new personnel, but it also serves as a reference for experienced personnel.

This is why the Operator's Manual must be kept at hand in the machine. The operator must carefully read and understand the Operator's Manual before starting up, servicing or repairing the machine.

This Operator's Manual will help to familiarize yourself more easily with the machine, thereby enabling you to use it more safely and efficiently.

This Operator's Manual does not include special superstructures.

Please contact your dealer if you require more information on the machine or the Operator's Manual.

Explanation of symbols and abbreviations

Explanation of symbols

- Identifies a list
 - Identifies a subdivision of a list
 - Description of a result
- 1. Identifies an activity
Follow the order of the activity!
- 2. Continuation of an activity
Follow the order of the activity!
- A** Identifies an alphabetical list
- B** Continuation of an alphabetical list
- Cross references: see page [1-1](#) (page)
- Cross references: **7** (pos. no. or table no.)
- Cross references: [fig. 3](#) (fig. no. 1)
- Cross references: – see [chapter “5 Operation” on page 5-1](#)
(see chapter)
- Cross references: – see [“Operation” on page 5-1](#) (– see text)



Information

Identifies an information that, when followed, provides for a more efficient and economical use of the machine.



Environment

Failure to observe the instructions identified by this symbol can cause damage to the environment.

Abbreviations (in alphabetic order)

Fig.	Figure
o/h	Operating hours
approx.	approximately
PCM	particulate matter catalysts
FGPS	Front Guard Protective Structure
FOPS	Falling Objects Protective Structure
if nec.	if necessary
max.	maximum
min.	minimum
Pos.	Position
ROPS	Roll Over Protective Structure (without losing contact with the ground)
TOPS	Tip Over Protective Structure
e.g.	for example

Definitions

Towing	The dumper tows another vehicle on public roads, or is towed itself.
Towing	The dumper is towed out of an immediate danger zone (for example a railroad crossing or job site).
Operating company/person	A company (or person) operating the machine. This can be a construction company, for example.
Operators	Person performing machine travel or operation.
Machine	Unless otherwise specified, the term “ machine ” refers to the dumpers described in this Operator’s Manual.
Machine operation	All work (for example machine travel, moving material, daily maintenance) an operator is allowed to or has to perform in connection with the machine. The term “ machine operation ” does not include maintenance only a Wacker Neuson service center is allowed to perform.
Visual aids	Visual aids are, for example, rearview mirrors, cameras, but also persons assisting the operator during machine operation.
Tier III/Tier IV (exhaust-gas standards)	The machine can be equipped with an Tier III or Tier IV engine, depending on the destination country. Both engine variants are described separately if there are engine-specific differences (for example regarding operation).

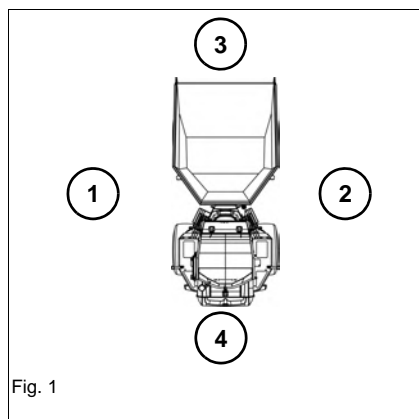

Right/left/front/rear

These terms are used as seen by the operator on the seat.

- 1: left
- 2: right
- 3: front
- 4: rear

Fig. 1

Target-group definition

This Operator's Manual is intended both for professional personnel on construction sites accustomed to handling construction machines, and also for private persons, for example, renting and operating a construction machine.

The Operator's Manual has been written in a way that allows machine operation by trained private persons without any special knowledge. As far as possible, no technical terms specific to construction machines are used.

This Operator's Manual must be fully read and understood both by private persons and the professional personnel on construction sites.

A dealer or person renting the machine must instruct the operator and have this confirmed in writing.

Operator qualification and requirements for safe operation

Among other things, safe machine operation depends on the following points:

- Machine model and equipment.
- Machine maintenance.
- Work and travel speed.
- Nature of ground and work environment.

The most important points are the operator's qualification and power of judgement. A well-trained operator following the Operator's Manual and maintenance plan ensures a long service life and durability of the machine.

Specific training enables the operator to acquire, among other things, the following skills:

- Correct assessment of work situations.
- Feeling for the machine.
- Recognition of possible risk situations.
- Safe working by making the correct decisions for man, machine and the environment.

The operator is at risk if the machine is not operated correctly.

Follow the operating procedures and instructions described for the machine.

Access to the machine or machine operation is prohibited for children and persons under the influence of alcohol, drugs or medicine.

Conversion table

The rounded imperial values are indicated in brackets, for example 1060 cm³ (64.7 in³).

Volume unit	
1 cm ³	(0.061 in ³)
1 m ³	(35.31 ft ³)
1 ml	(0.034 US fl.oz.)
1 l	(0.26 gal)
1 l/min	(0.26 gal/min)
Unit of length	
1 mm	(0.039 in)
1 m	(3.28 ft)
Weight	
1 kg	(2.2 lbs)
1 g	(0.035 oz)
Pressure	
1 bar	(14.5 psi)
1 kg/cm ²	(14.22 lbs/in ²)
Force/output	
1 kN	(224.81 lbf)
1 kW	(1.34 hp)
1 PS	(0.986 hp)
Torque	
1 Nm	(0.74 ft.lbs.)
Speed	
1 kph	(0.62 mph)
Acceleration	
1 m/s ²	(3.28 ft/s ²)

1.2 Warranty and liability

Exemption from warranty and liability

Warranty

Warranty claims can be made only if the conditions of warranty have been observed. They are included in the General Conditions of Sales and Delivery for new machines and spare parts sold by the dealers of Wacker Neuson Linz GmbH. Furthermore, all instructions in this Operator's Manual must be observed.

Have the maintenance, delivery inspection and the entries in the service booklet performed by a Wacker Neuson service center, otherwise warranty claims will not be acknowledged.

Exemption from liability

- Modifying Wacker Neuson products and fitting them with additional equipment not included in our delivery program requires Wacker Neuson's written authorization, otherwise warranty and product liability for possible damage caused by these modifications shall not be applicable.
- The safety of the machine can be negatively affected by performing machine modifications without proper authority and by using spare parts, equipment, attachments and optional equipment that have not been checked and released by Wacker Neuson GmbH. Warranty and product liability for possible damage caused by these modifications shall not be applicable.
- Wacker Neuson Linz GmbH shall not be liable for injury or damage to property that can be caused by failure to observe the safety instructions and the Operator's Manual, and by the negligence of the duty to exercise due care when:
 - handling
 - operating
 - servicing and performing maintenance and
 - repairing the machine. This is also applicable in those cases in which special attention has not been drawn to the duty to exercise due care, in the safety instructions as well as in the Operator's and maintenance manuals.
 - Read and understand the Operator's Manual before starting up, servicing or repairing the machine. Observe all safety instructions.

Notes:

2 Safety

2.1 Safety symbols and signal words

Explanation

The following symbol identifies safety instructions. It is used for warning against potential personal risk or danger.

DANGER

DANGER identifies a situation causing death or serious injury if it is not avoided.

Consequences in case of non-observance.

- ▶ Avoidance of injury or death.
-

WARNING

WARNING identifies a situation that can cause death or serious injury if it is not avoided.

Consequences in case of non-observance.

- ▶ Avoidance of injury or death.
-

CAUTION

CAUTION identifies a situation that can cause injury if it is not avoided.

Consequences in case of non-observance.

- ▶ Avoidance of injury.
-

NOTICE

NOTICE identifies a situation that causes damage to the machine if it is not observed.

- ▶ Avoidance of damage to property.
-

2.2 Qualification of operating personnel

Owner's duties

- Only allow specifically authorized, trained and experienced persons to operate, drive and perform maintenance on the machine.
- Do not allow persons to be trained or instructed by anyone other than an authorized and experienced person.
- Have persons to be trained or instructed practice under supervision until they are familiar with the machine and its behavior (for example with the steering and braking behavior).
- Access to the machine or machine operation is prohibited for children and persons under the influence of alcohol, drugs or medicine.
- Clearly and unequivocally define the responsibilities of the operating and maintenance personnel.
- Clearly and unequivocally define the responsibilities on the job site, also in view of traffic regulations.
- Give the operator the authority to refuse instructions by other persons that are contrary to safety.
- Have the machine serviced and repaired only by a Wacker Neuson service center.

Required knowledge of operator

- The operator is responsible for other persons.
- Avoid any operational mode that might be prejudicial to safety.
- The specific national driving license is required.
- The machine may only be operated by authorized and safety-conscious persons who are fully aware of the risks involved in operating the machine.
- The operator and owner are obligated to operate the machine only in a safe and working condition.
- All persons working on or with the machine must have read and understood the safety instructions in this Operator's Manual before starting work.
- Follow, and instruct the operator in, legal and other mandatory regulations relevant to accident prevention.
- Observe and instruct the operator in regulations regarding road traffic and environmental protection.
- Use only the defined accesses for getting on and off the machine.
- Be familiar with the emergency exit of the machine.

Preparatory measures for the operator

- Before starting, check the machine whether it can be driven and operated safely.
- Tie back long hair and remove all jewelry.
- Wear close-fitting work clothes that do not hinder movement.

2.3 Conduct

Prerequisites for operation

- The machine has been designed and built in accordance with state-of-the-art standards and the recognized safety regulations. Nevertheless its use can cause danger to the operator or other persons, or damage to the machine.
- Store this Operator's Manual in the place provided for this in or on the machine. Immediately replace a damaged or illegible Operator's Manual and any supplements to it.
- The machine must only be operated in accordance with its designated use and the instructions set forth in this Operator's Manual.
- The operator and owner are obligated not to put into operation or operate a damaged or malfunctioning machine.
 - If a damage or malfunction occurs during operation, put the machine out of operation immediately and secure it against restart.
 - Have all malfunctions jeopardizing the safety of the operator or other persons immediately repaired by a Wacker Neuson service center.
- Do not put the machine into operation or operate it after an accident; have it inspected for damage by a Wacker Neuson service center.
 - Have the seat belt replaced by a Wacker Neuson service center after an accident, even if there is no visible damage.
 - Cabin and protective structures
- Remove all dirt, snow and ice from climbing aids (for example from the handholds, footholds, handrails).
- The owner is responsible for requiring the operating and maintenance personnel to wear protective clothing and equipment as required by the circumstances.

2.4 Operation

Preparatory measures

- Operation is only allowed with correctly installed and intact protective structures.
- Keep the machine clean. This reduces injury, accident and fire hazards.
- Safely store objects you carry with you in the places provided for this (for example in the storage compartment, drinks holder).
- Do not carry objects with you that protrude into the operator's work space. They can create another danger in case of an accident.
- Observe all safety, warning and information labels.
- Start and operate the machine only with the seat belt fastened and only from the place provided for this.
- Check the condition and the fastening of the seat belt. Have malfunctioning seat belts and mounting hardware replaced by a Wacker Neuson service center.
- Before starting work, adjust the seating position so that all control elements can be reached and fully operated.
- Perform the personal adjustment at machine standstill only (for example of the operator seat, steering column).
- Ensure that all safety devices are properly installed and functional before starting work.
- Before starting work or after interrupting work, ensure that the brake, steering, signaling and light systems are functional.
- Before putting the machine into operation, ensure that nobody is in the danger zone.

Job site

- The operator is responsible for other persons.
- Before starting work, familiarize yourself with the job site. This applies to, for example:
 - Obstacles in the job site and machine travel area
 - Any barriers separating the job site from public roads
 - Soil weight-bearing capacity
 - Existing overhead and underground lines
 - Special operating conditions (for example dust, steam, smoke, asbestos)
- The operator must know the maximum dimensions of the machine and the attachment – see “Technical data”.
- Maintain a safe distance (for example from buildings, edges of building pits).
- During work in buildings or in enclosed areas, look out for:
 - Height of the ceiling/clearances
 - Width of entries/passages
 - Maximum load of ceilings and floors
 - Sufficient room ventilation (for example risk of carbon monoxide poisoning)
- Use existing visual aids to stay aware of the danger zone.
- In conditions of darkness and poor visibility, switch on existing work lights and ensure that motorists are not blinded by these lights.
- If the existing lights of the machine are not sufficient for performing work safely, ensure additional lighting of the job site.
- Due to hot machine parts, maintain a safe distance from easily flammable material (for example from hay, dry leaves).

Danger zone

- The danger zone is the area in which persons are in danger due to the movements of the machine, attachment and/or load.
- The danger zone also includes the area that can be affected by falling material, equipment or by debris that is thrown out.
- Extend the danger zone sufficiently in the immediate vicinity of buildings, scaffolds or other elements of construction.
- Seal off the danger zone should it not be possible to keep a sufficient safety distance.
- Stop machine operation immediately if persons do not stay clear of the danger zone.

Carrying passengers

- Carrying passengers with the machine is PROHIBITED.
- Carrying passengers on/in attachments/tools is PROHIBITED.
- Carrying passengers on/in trailers is PROHIBITED.

Mechanical integrity

- The operator and owner are obligated to operate the machine only in a safe and working condition.
- Operate the machine only if all protective and safety-oriented equipment (for example protective structures such as a cabin or rollbar, removable safety devices) is installed and functional.
- Check the machine for visible damage and defects.
- In case of damage and/or unusual behavior, put the machine out of operation immediately and secure it against restart.
- Have all malfunctions jeopardizing the safety of the operator or other persons immediately repaired by a Wacker Neuson service center.

Starting the engine of the machine

- Start the engine only according to the Operator's Manual.
- Observe all warning and indicator lights.
- Do not use any liquid or gaseous starting aids (for example ether or starting fuel).

Machine operation

- Start and operate the machine only with the seat belt fastened and only from the place provided for this.
- Put the machine into operation only if visibility is sufficient (have another person guide you if necessary).
- Operation on slopes:
 - Travel/work only uphill or downhill.
 - Avoid machine travel across a slope, observe the machine's permissible inclination (and of the trailer if necessary).
 - Keep loads on the uphill side of the machine and as close as possible to it.
 - Keep attachments/work equipment close to the ground.
- Adapt the travel speed to the circumstances (for example the ground conditions, weather conditions).
- There is increased danger during backward machine travel. Persons in the blind spot of the machine cannot be seen by the operator.
 - Ensure that nobody is in the danger zone when you change the travel direction.
- Never get on a moving machine and never jump off the machine.

Machine travel on public roads/sites

- The specific national driving license is required.
- Observe the national regulations (for example the road traffic regulations) during machine travel on public roads/sites.
- Ensure that the machine is in compliance with the national regulations.
- In order not to blind other motorists, using the existing work lights during machine travel on public roads/site is prohibited.
- When crossing underpasses, bridges, tunnels, for example, ensure that the clearance height and width is sufficient.
- The attachment fitted onto the machine must be certified for travel on public roads/sites (see for example the registration documents).
- The attachment fitted onto the machine must be empty and in transport position.
- The attachment fitted onto the machine must be equipped with the mandatory lights and protective equipment.
- Take measures against unintentional operation of the operating hydraulics.
- If the machine has different steering modes, ensure that the mandatory steering mode is selected.

Stopping the engine of the machine

- Stop the engine only according to the Operator's Manual.
- Before stopping the engine, lower the work equipment/attachment to the ground.

Stopping and securing the machine

- Unbuckle the seat belt only after stopping the engine.
- Before leaving the machine, secure it to prevent it from rolling away (for example with the parking brake, suitable wheel chocks).
- Remove the starting key and secure the machine against unauthorized operation.

2.5 Lifting gear applications

Requirements

- Have loads fastened and the operator guided by a qualified person having specific knowledge of lifting gear applications and the usual hand signals.
- The person giving instructions to the operator must stay in visual contact with the operator when fastening, guiding or removing the load (maintain visual contact).
- If this not be possible, ask one more person with the same qualifications to guide.
- The operator may not leave his seat as long as the load is raised.

Fastening, guiding and removing loads

- Follow the applicable specific regulations for fastening, guiding and removing a load.
- Wear protective clothing and equipment when fastening, guiding and removing loads (for example a hard hat, safety glasses, protective gloves, safety boots).
- Do not place lifting and fastening gear over sharp edges or rotating parts. Loads must be fastened so as to prevent them from slipping or falling.
- Move loads only on horizontal, level and firm ground.
- Move loads close to the ground.
- In order to avoid oscillating movements of loads:
 - Perform smooth, slow movements with the machine.
 - Use cables to guide the load (do not use hands to guide).
 - Bear in mind the weather conditions (for example the wind force).
 - Keep a minimum safety distance from objects.
- The operator may allow the load to be fastened and removed only if the machine and its work equipment are not being moved.
- Danger zones must not overlap with the work zones of other machines.

Lifting gear applications

- The machine must be certified for lifting gear applications.
- Observe the national regulations for lifting gear applications.
- Lifting gear applications are procedures involving raising, transporting and lowering loads with the help of lifting and fastening gear.
- The help of an accompanying person is necessary for fastening, guiding and removing the load.
- There must be nobody under the load.
- Stop the machine immediately and stop the engine if persons enter the danger zone.
- Use the machine for lifting gear applications ONLY if the mandatory lifting gear (for example a joint rod and load hook) and safety equipment (for example optical and acoustic warning devices, hose burst valve, stability table) is installed and functional.
- Use only lifting and fastening gear certified by a test/certification body, observe the inspection intervals (Use only chains and shackles. No belts, slings or cables).
- Do not use any lifting and fastening gear that is dirty, damaged or not of sufficient size.
- Do not interrupt the work process with a load attached.

2.6 Trailer operation

Trailer operation

- The machine must be certified for trailer operation.
- Observe the national regulations for trailer operation.
- The specific national driving license is required.
- Carrying passengers on/in trailers is PROHIBITED.
- Observe the maximum permissible vertical and trailer load.
- Do not exceed the permissible trailer speed.
- Trailer operation with the towing gear of the machine is prohibited.
- Trailer operation changes the machine's operating behavior, the operator must be familiar with this and act accordingly.
- Bear in mind the machine's steering mode and the trailer's turning circle.
- Before hitching/unhitching the trailer, secure it to prevent it from rolling away (for example with the parking brake, suitable wheel chocks).
- There must be nobody between the machine and the trailer when hitching a trailer.
- Hitch the trailer onto the machine correctly.
- Ensure that all equipment works correctly (for example the brakes, lights).
- Before starting machine travel, ensure that nobody is between the machine and the trailer.

2.7 Attachment operation

Attachments

- Use only attachments that are certified for the machine or its protective equipment (for example a shatter protection).
- All other attachments require the machine manufacturer's release.
- The danger zone and the work zone depend on the attachment used – see the Operator's Manual of the attachment.
- Secure the load.
- Do not overload attachments.
- Check the correct position of the lock.

Operation

- Carrying persons on/in an attachment is prohibited.
- Installing a work platform is prohibited.
 - Exception: The machine is certified and equipped with the necessary safety equipment.
- Attachments and counterweights modify handling, as well as the steering and brake capability of the machine.
- The operator must be familiar with these modifications and act accordingly.
- Before starting work, operate the attachment to check that it works correctly.
- Before putting the attachment into operation, ensure that nobody is in danger.
- Lower the attachment to the ground before leaving the operator seat.

Removing and fitting attachments

- Before uncoupling or coupling hydraulic connections:
 - Stop the engine
 - Releasing the pressure in the operating hydraulics
- Picking up and lowering attachments to the ground requires special care:
 - Pick up and safely lock the attachment in accordance with the Operator's Manual.
 - Lower the attachment only to firm, level ground and secure it to prevent it from tipping over or rolling away.
- Put the machine and the attachment into operation only if:
 - The protective equipment has been installed and is functional.
 - The connections for the lights and the hydraulic system have been established and are functional.
- Perform a visual check of the lock after locking the attachment.
- There must be nobody between the machine and the equipment when picking up or lowering an attachment to the ground.

2.8 Towing, loading and transporting

Towing

- Seal off the danger zone.
- Ensure that no one is near the towing bar or cable. The safety distance is equal to 1.5 times the length of the towing equipment.
Use a towing cable for machines with a total weight of up to 4.0 tons.
Use a towing bar for machines with a total weight of over 4.0 tons.
- Observe the mandatory transport position, permissible speed and itinerary.
- A tractor vehicle of the same weight category must be used as a minimum. Furthermore, the tractor vehicle must be equipped with a safe braking system and sufficient tractive power.
- Use only towing bars or cables certified by a test/certification body, observe the inspection intervals.
- Do not use any towing bars or cables that are dirty, damaged or not of sufficient size.
- Fasten towing bars or cables only at the defined points.
- Tow away only in accordance with this Operator's Manual to avoid damage to the machine.
- Observe the national regulations (for example the light regulations) when towing on public roads/sites.

Crane-lifting

- Seal off the danger zone.
- The crane and the lifting gear must have suitable dimensions.
- Observe the machine's overall weight – see "Technical data".
- Wear protective clothing and equipment when fastening, guiding and removing the machine (for example a hard hat, safety glasses, safety boots).
- Use only lifting and fastening gear certified by a test/certification body (for example cables, belts, hooks, shackles), observe the inspection intervals.
- Do not use any lifting and fastening gear that is dirty, damaged or not of sufficient size.
- Perform a visual check to ensure that all slinging points are neither damaged nor worn (no widening, no sharp edges, no cracks).
- Have loads fastened and crane operators only guided by experienced persons.
- The person guiding the crane operator must be within sight or sound of him.
- Observe all movements of the machine and lifting gear.
- Secure the machine against unintentional movement.
- Raise the machine only after it is safely attached and the person attaching the machine has given his approval.
- Use only the slinging points provided for fastening the lifting gear (for example cables, belts).
- Do not attach the machine by twining the lifting gear (for example cables, belts) around it.
- Ensure an even load distribution (center of gravity!) when fastening the lifting gear.
- Ensure that no one is in, on or under the machine when loading the machine.
- Observe the national regulations (for example "Merkheft Erdbau-maschinen", leaflet on earth moving machines of the German employers' liability insurance association for construction engineering).
- Load the machine only in accordance with this Operator's Manual to avoid damage to the machine.
- Do not raise a machine that is stuck or frozen onto the ground, for example.
- Bear in mind the weather conditions (for example the wind force, visibility conditions).

Transportation

- For the safe transportation of the machine:
 - The transport vehicle must have a sufficient load capacity and platform – see “Technical data”
 - The maximum weight rating of the transport vehicle must not be exceeded.
- Use only lifting and fastening gear certified by a test/certification body, observe the inspection intervals.
- Do not use any lifting and fastening gear that is dirty, damaged or not of sufficient size.
- In order to secure the machine on the platform, use only the fastening points provided for this purpose.
- Ensure that nobody is in or on the machine during transportation.
- Observe the national regulations (for example “Merkheft Erdbau-maschinen”, leaflet on earth moving machines of the German employers’ liability insurance association for construction engineering).
- Bear in mind the weather conditions (for example ice, snow).
- Ensure the minimum load on the steering axle(s) of the transport vehicle, and ensure an even load distribution.

2.9 Maintenance

Maintenance

- Observe the intervals prescribed by law and those specified in this Operator’s Manual for routine checks/inspections and maintenance.
- For inspection and maintenance, ensure that all tools and service center equipment are adapted to the performance of the task described in this Operator’s Manual.
- Do not use any damaged or malfunctioning tools.
- Have hydraulic hoses replaced within stipulated intervals even if no visual defects can be detected.
- The machine and the engine must be stopped during maintenance.
- Once maintenance is over, correctly install safety equipment again that has been removed.
- Wait for the machine to cool down before touching components.

Personal safety measures

- Avoid any operational mode that might be prejudicial to safety.
- Wear protective clothing and equipment (for example a hard hat, protective gloves, safety boots).
- Tie back long hair and remove all jewelry.
- If maintenance on a running engine cannot be avoided:
 - Only work in groups of two.
 - Both persons must be authorized and trained for the operation of the machine.
 - One person must be seated on the operator seat and stay in contact with the second person.
 - Keep a safe distance from rotating parts (for example from fan blades, belts).
 - Keep a safe distance from hot parts (for example from the exhaust system).
 - Perform maintenance only in well-ventilated rooms or rooms with an exhaust-gas suction system.
- Safely lock/support machine components before starting work.
- Apply special care when working on the fuel system due to the increased fire hazard.

Preparatory measures

- Attach a warning label to the control elements (for example “Machine being serviced, do not start”).
- Before performing assembly work on the machine, support the areas to be serviced and use suitable lifting and supporting equipment for the replacement of parts over 9 kg (20 lbs.).
- Perform maintenance only if:
 - the machine is positioned on firm and level ground
 - the machine is secured to prevent it from rolling away (for example with the parking brake, wheel chocks), and if all attachments/the work equipment is lowered to the ground
 - the engine is stopped
 - the starting key has been removed
 - the pressure in the operating hydraulics has been released
- If maintenance has to be performed under a raised machine/attachment, support the machine/attachment (for example with a lift platform, trestles) ensuring safety and stability.
- Hydraulic cylinders or jacks alone do not sufficiently secure a raised machine/attachment.

Measures for performing maintenance

- Perform only the maintenance described in this Operator’s Manual.
- All work that is not described in this Operator’s Manual must be performed by qualified and authorized technical personnel.
- Follow the maintenance plan – see “Maintenance plan”.
- Always use specially designed or otherwise safety-oriented ladders and working platforms to perform overhead maintenance. Do not use machine parts or attachments as a climbing aid.
- Do not use attachments/work equipment as a lift platform for persons.
- Remove all dirt, snow and ice from climbing aids (for example from the handholds, footholds, handrails).
- Disconnect the negative terminal of the battery before working on the electrical system.

Modifications and spare parts

- Do not modify the machine and the work equipment/attachment (for example the safety equipment, lights, tires, straightening and welding work).
- Modifications must be approved by the manufacturer and performed by a Wacker Neuson service center.
- Use only original spare parts.

Protective structures

- The cabin, rollbar and protective screen are tested protective structures and may not be modified (for example no drilling, bending, welding).
- Perform a visual check according to the maintenance plan (for example check fastenings for damage).
- If damage or defects are detected, have them immediately checked and repaired by a Wacker Neuson service center.
- Have retrofitting work only performed by a Wacker Neuson service center.
- Replace self-locking fasteners (for example self-locking nuts) by new ones after removing them.

2.10 Measures for avoiding risks

Tires

- Have repair work on the tires only performed by trained technical personnel.
- Check the tires for correct pressure and visible damage (for example cracks, cuts).
- Tighten the wheel nuts to the specified tightening torque. (see chapter 7.18 Tires/tracks).
- Use only approved tires.
- The machine must have identical tires (for example profile, revolutions per mile).

Tracks

- Repair work on tracks may only be performed by trained technicians.
- Check the tracks for correct tension and visible damage (for example cracks, cuts).
- Proceed with extreme care on slippery ground (for example on steel plates, ice), increased slipping hazard.
- Use only approved tracks.

Hydraulic and compressed-air system

- Check all lines, hoses and threaded fittings regularly for leaks and visible damage.
- Splashed oil can cause injury and fire.
- Leaking hydraulic and compressed-air lines can cause the full loss of the brake effect.
- Have damage and leaks immediately repaired by a Wacker Neuson service center.
- Have hydraulic hoses replaced by a Wacker Neuson service center within stipulated intervals even if no visual defects can be detected.

Electrical system

- Use only fuses with the specified current rating.
- In case of damage or malfunction in the electrical system:
 - Put the machine out of operation immediately and secure it against restart
 - Disconnect the battery or operate the battery master switch
 - Have the malfunction repaired
- Ensure that work on the electrical system is only performed by trained technical personnel.
- Have the electrical system checked regularly and malfunctions repaired immediately (for example loose connections, scorched cables).
- The operating voltage of machine, the attachment and the trailer must be the same (for example 12 V).

Battery

CALIFORNIA

Proposition 65 Warning

Battery posts, terminals and related accessories contain lead and lead compounds, chemical known to the State of California to cause cancer and reproductive harm. Wash hands after handling.

- Batteries contain caustic substances (for example sulfuric acid). When handling the battery observe the specific safety instructions and regulations relevant to accident prevention.
- A volatile oxyhydrogen mixture forms in batteries during normal operation and especially during charging. Always wear gloves and eye protection when working with batteries.
- Do not perform battery maintenance near open flames.
- Perform battery maintenance only in well-ventilated areas (for example due to vapors harmful to health, explosion hazard).
- Starting the machine with battery jumper cables is dangerous if performed improperly. Observe the safety instructions regarding the battery.

Safety instructions regarding internal combustion engines

CALIFORNIA

Proposition 65 Warning

Engine exhaust, some of its constituents, and certain vehicle components contain or emit chemicals known to the State of California to cause cancer and birth defects or other reproductive harm.

- Internal combustion engines present special hazards during operation and fueling.
- Failure to follow the warnings and safety instructions can cause serious injury or death.
- Keep the area around the exhaust system free of flammable materials.
- Check the engine and fuel system for leaks (for example loose fuel lines). Do not start or let the engine run in case of leaks.
- Breathing the exhaust fumes causes death very quickly.
- Engine exhaust contains gases you cannot see or smell (for example carbon monoxide and dioxide).
 - Never operate the machine in enclosed premises or areas (for example in pits), if there is no suitable ventilation (for example exhaust-gas filters, suction systems).
- Do not operate the machine in potentially explosive areas.
- Do not touch the engine, exhaust system and cooling system as long as the engine is still running or has not cooled down yet.
- Do not remove the radiator cap when the engine is running or hot.
- The coolant is hot, under pressure and can cause serious burns.

Bleeding the fuel system and refueling

- Do not bleed the fuel system or refuel near open flames.
- Bleed the fuel system and refuel only in well-ventilated areas (for example due to vapors harmful to health, explosion hazard).
- Wipe away fuel spills immediately (for example due to fire hazard, slipping hazard).
- Firmly close the fuel tank cap, replace a malfunctioning fuel tank cap.

Handling oil, grease and other substances

- When handling oil, grease and other chemical substances (for example the battery electrolyte, coolant), observe the safety data sheets.
- Wear appropriate protective equipment (for example protective gloves, safety glasses).
- Be careful when handling hot consumables – burn hazard.
- In polluted environment (dust, vapors, smoke, asbestos), work only with appropriate personal protective equipment (for example with a breathing mask).
- Do not use machine in radioactive, biological or chemical contaminated areas.

Fire hazard

- Fuel, lubricants and coolants are flammable.
- Do not put the machine into operation if there is a fire hazard.
- Do not use flammable detergents.
- Keep the area around the exhaust system free of flammable materials.
- Due to hot machine parts, maintain a safe distance from easily flammable material (for example from hay, dry leaves).
 - Stop and park the machine only in fire-protected areas.
- If the machine is equipped with a fire extinguisher, have it installed in its specific location.
- Keep the machine clean to reduce the fire hazard.

Working near electric supply lines

- Before performing any work, the operator must check whether there are any electric supply lines in the job site.
- If there are electric supply lines, only a machine with cabin may be used (Faraday cage).
- Keep a safe distance from existing electric supply lines.
- If this is not possible, the operator must take other safety measures (for example switching off the current) in agreement with the operating company or owner of the supply lines.
- If supply lines are exposed, they must be fastened, supported and secured accordingly.
- If live supply lines are touched nevertheless:
 - Do not leave/touch the cabin (Faraday cage)
 - If possible, drive the machine out of the danger zone
 - Warn others against approaching and touching the machine
 - Have the live wire de-energized
 - Do not leave the machine until the supply lines that have been touched or damaged have been safely de-energized

Working near non-electric supply lines

- Before performing any work, the operator must check whether there are any non-electric supply lines in the job site.
- If there are non-electric supply lines, the operator must take safety measures (for example switching off the supply line) in agreement with the operating company or owner of the supply lines.
- If supply lines are exposed, they must be fastened, supported and secured accordingly.

Behavior during thunderstorm

- Stop machine operation if a thunderstorm is gathering, stop the machine, secure and leave it, and avoid being near it.

Noise

- Observe the noise regulations (for example during applications in enclosed premises).
- Bear in mind external sources of noise (compressed-air hammer, concrete saw).
- Do not remove the sound baffles of the machine/attachment.
- Have damaged sound baffles immediately replaced (for example an insulating mat, muffler).
- Before starting work, get informed on the noise level of the machine/attachment (for example on the adhesive label) – wear ear protectors.
- Do not wear ear protectors during machine travel on public roads/sites.

Cleaning

- Injury hazard from compressed air and high-pressure cleaners.
 - Wear appropriate protective clothes.
- Do not use any dangerous and aggressive detergents.
 - Wear appropriate protective clothes.
- Operate the machine only in a clean condition.
 - Remove all dirt, snow and ice from climbing aids (for example from the handholds, footholds, handrails).
 - Keep the cabin glazing and visual aids clean.
 - Keep the light system and reflectors clean.
 - Keep the control elements and indicators clean.
 - Keep the safety, warning and information labels clean, and replace damaged and missing labels by new ones.
- Perform cleaning work only if the engine is stopped and cooled down.
- Bear in mind sensitive components and protect them accordingly (for example electronic control units, relays).

3 Introduction

3.1 Machine overview

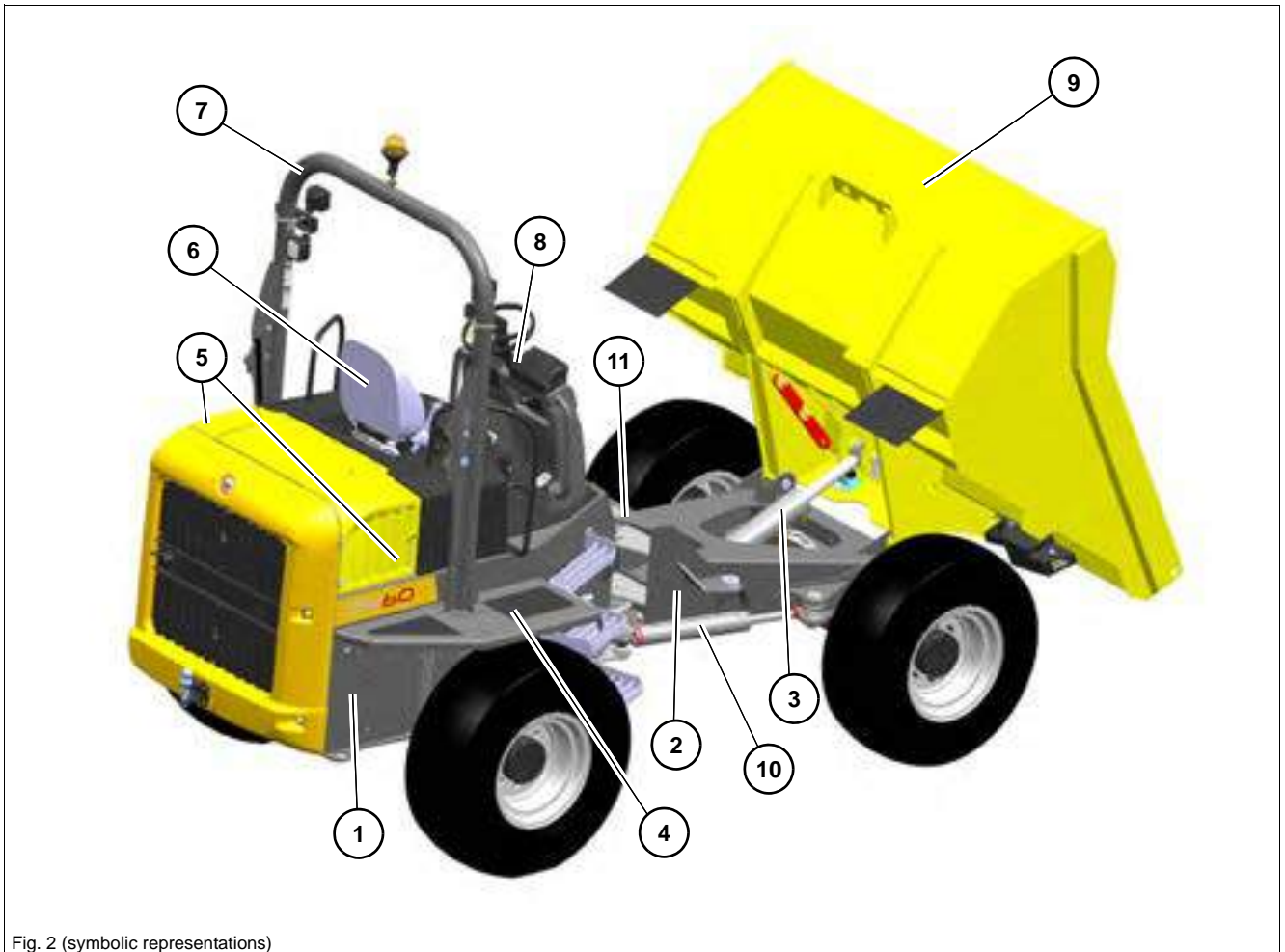

Fig. 2 (symbolic representations)

No.	Designation	No.	Designation
1	Rear chassis	7	Rollbar
2	Front chassis	8	Control stand
3	Tilt cylinder	9	Skip
4	Mudguard	10	Steering cylinder
5	Engine cover/ maintenance flap on left und right	11	Articulated joint
6	Operator seat		

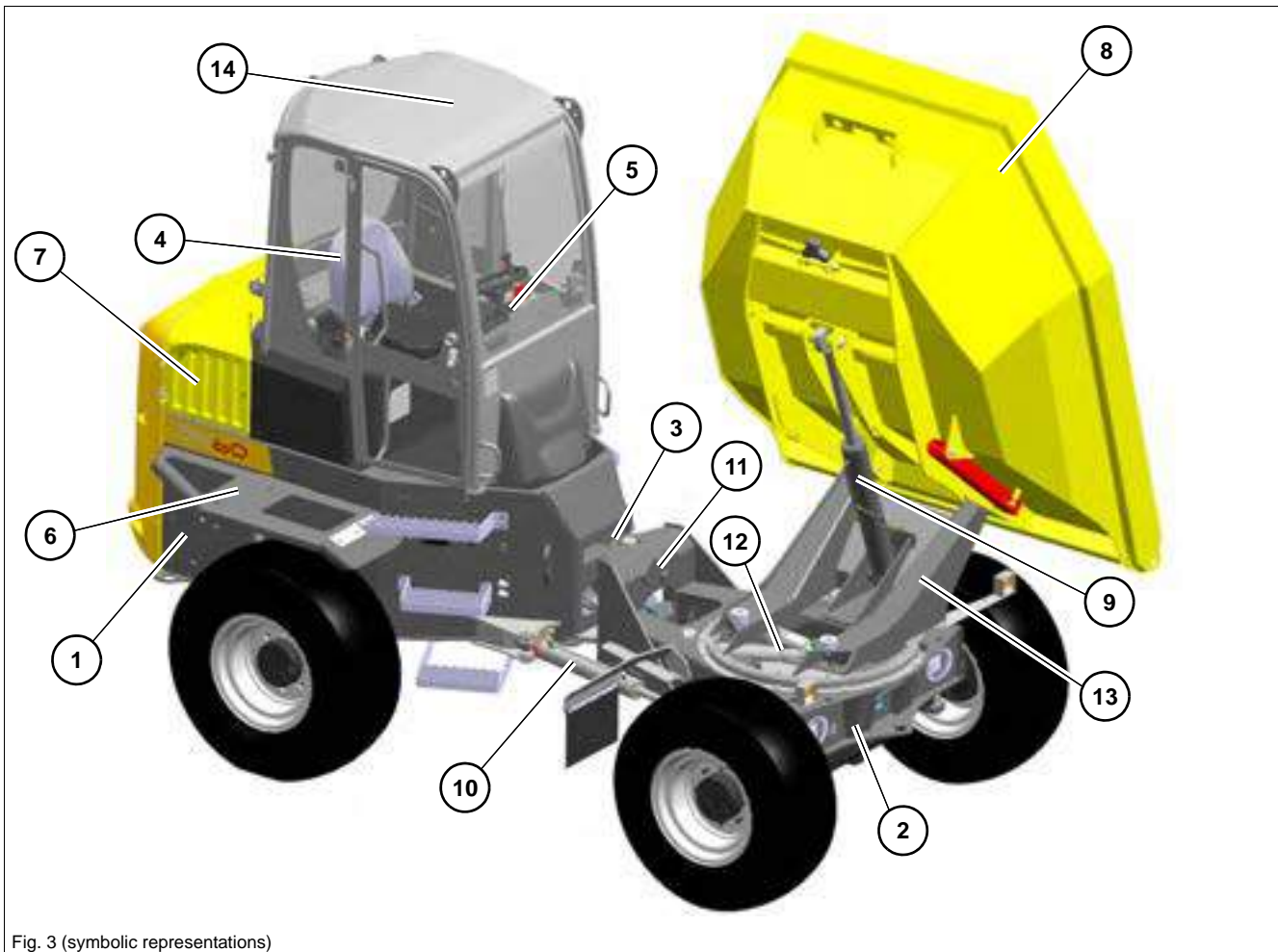

Fig. 3 (symbolic representations)

No.	Designation	No.	Designation
1	Rear chassis	8	Skip
2	Front chassis	9	Tilt cylinder
3	Articulated joint	10	Steering cylinder
4	Operator seat	11	Swivel centring
5	Control stand	12	Swiveling cylinder
6	Mudguard	13	Swiveling console
7	Engine cover/ maintenance flap on left und right	14	Cabin

3.2 Brief description of machine

Overview of models and trade names

Machine model/machine designation	Trade name
D18-01	DW60
D18-02	DW90
D18-03	DW100

The Wacker Neuson model D18 dumpers are self-propelled work machines.

These powerful, highly flexible and efficient construction machines with minimum environmental impact are mainly used for moving earth, gravel and rubble on construction sites.

Follow the relevant national and regional regulations.

The main components of the machine are:

- Sturdy steel sheet chassis
- Front skip or swivel skip (option)
- Rollbar or cabin (option)
- Four-cylinder Perkins diesel engine 55 kW/62.5 kW/86 kW
- Articulated machine
- 2 rigid axles
- Permanent 4 wheel drive



Information

The machine can be equipped with the **Telematic** option (for transmitting operating data, location, etc. via satellite).

Rollbar

- The rollbar has been specially designed for protection in case of an accident.
- TOPS/ROPS tested rollbar.

Cabin (option)

The cabin has been specially designed for protection in case of an accident.

- ROPS/TOPS tested cabin.
- The cabin complies with the FOPS level II requirements according to EN ISO 3449:2008.

3.3 Information and regulations on use

Designated use

- The machine is intended for:
 - Moving earth, gravel, coarse gravel or ballast and rubble.
Every other use is regarded as not designated for the use of the machine. Wacker Neuson will not be liable for damage resulting from use other than mentioned above. The operator/machine owner alone will bear the risk.
 - Designated use also includes observing the instructions set forth in the Operator's Manual and observing the maintenance and service conditions.
- Follow the national regulations for machine travel on public roads.

Earth moving machinery on public roads

Earth moving machines may be used on public roads only if they are equipped according to the road traffic regulations of your country.

Equipment

Austrian road traffic regulations, for example §53 StVO, require to have the following equipment on board:

- 1 warning vest according to ÖNORM EN 471
- 1 warning triangle with design certification
- 1 warning light with design certification
- 1 first-aid kit in accordance with the legal regulations of your country

Driving license

Earth moving machinery may be driven on public roads only if the operator has a driving license as stipulated by national road traffic regulations for a specific machine.

15, 20 or 25 kph

The design-specific maximum speed of 25 kph requires driving license category 5 (European driving license category L without weight limitation).

30 kph

A category 2 driving license (European driving license category C) is required for a design-specific maximum speed of over 25 kph and a gross weight rating of over 7.5 tonnes.

Machine inspections

All employer's liability insurance associations require a safety-specific inspection of the machine according to VBG 40 §50, which must be performed once a year by an expert (test report).

In addition, an inspection tag must be affixed to the machine to remind the operator when the next inspection by an expert is due.

Observe the legal regulations of your country for recurrent inspections.

Documents

- Driving license
- Test report according to VBG 40 §50

3.4 Labels

WARNING

Injury hazard due to missing or damaged labels!

Missing or incomplete warning and information labels can lead to situations with serious injury or death.

- ▶ Do not remove warning and information labels.
 - ▶ Immediately replace damaged warning and information labels.
-

Information

Type, quantity and position of the labels depend on options, country and machine.

Type labels



Fig. 4

Serial number

The serial number is stamped on the machine chassis. It is also located on the type label.

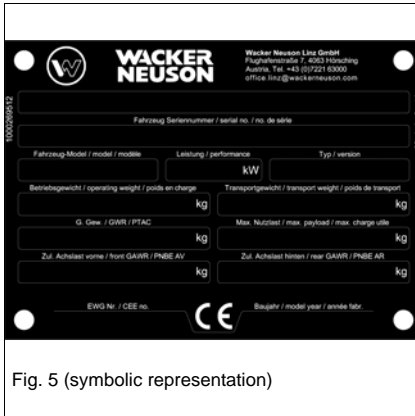

Type label

The type label is located at the front on the machine chassis.

Description of attachment	COMPACT DUMPER
Fahrzeug Seriennummer/serial no./no. de série	Machine serial number
Fahrzeug Modell/model/modèle:	Machine designation
Leistung/performance:	Engine power
Typ/version:	Machine model
Betriebsgewicht/operating weight/poids en charge:	Operating weight
Transportgewicht/ transport weight/ poids en transport:	Transport weight
G. Gew./GWR/PTAC:	Permissible maximum weight
Max. Nutzlast/max. payload/max. charge utile:	Maximum payload
Zul. Achslast vorne/front GAWR/PNBE AV:	Front gross axle weight rating
Zul. Achslast hinten/rear GAWR/PNBE AR:	Rear gross axle weight rating
EWG Nr./CEE no.:	EEC check number
Baujahr/model year/année fabr.:	Year of construction

Fig. 5 (symbolic representation)

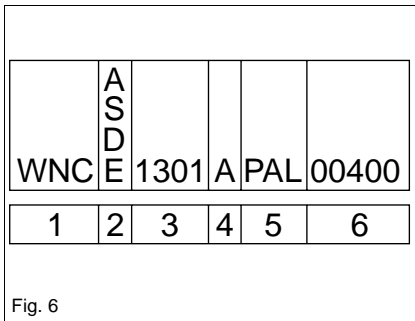

Fig. 6

17-digit serial number

For easier machine identification, Wacker Neuson introduced a 17-digit serial number for compact equipment (for example for excavators). This serial number includes additional data, for example the manufacturer code and the production site.

Position	Description
1	Manufacturer code
2	Machine model
A	Unit
S	Compact loader
D	Dumper
E	Excavator
3	Internal model designation
4	Check letter
5	Production site
6	Serial number

i Information

Wacker Neuson components (for example Easy Lock, tilt bucket, rollbar) have numeric serial numbers only.

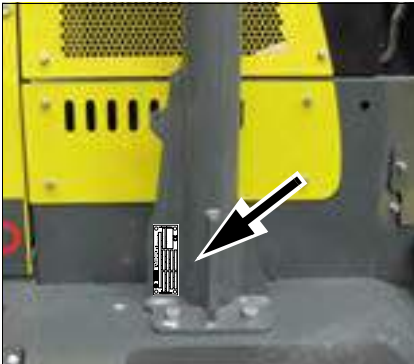

Fig. 7 (symbolic representation)

Rollbar type label

The type label is located on the right on the rollbar.



Fig. 8 (symbolic representation)

Cabin type label (option)

The type label is located on the B pillar on the left.

Warning labels

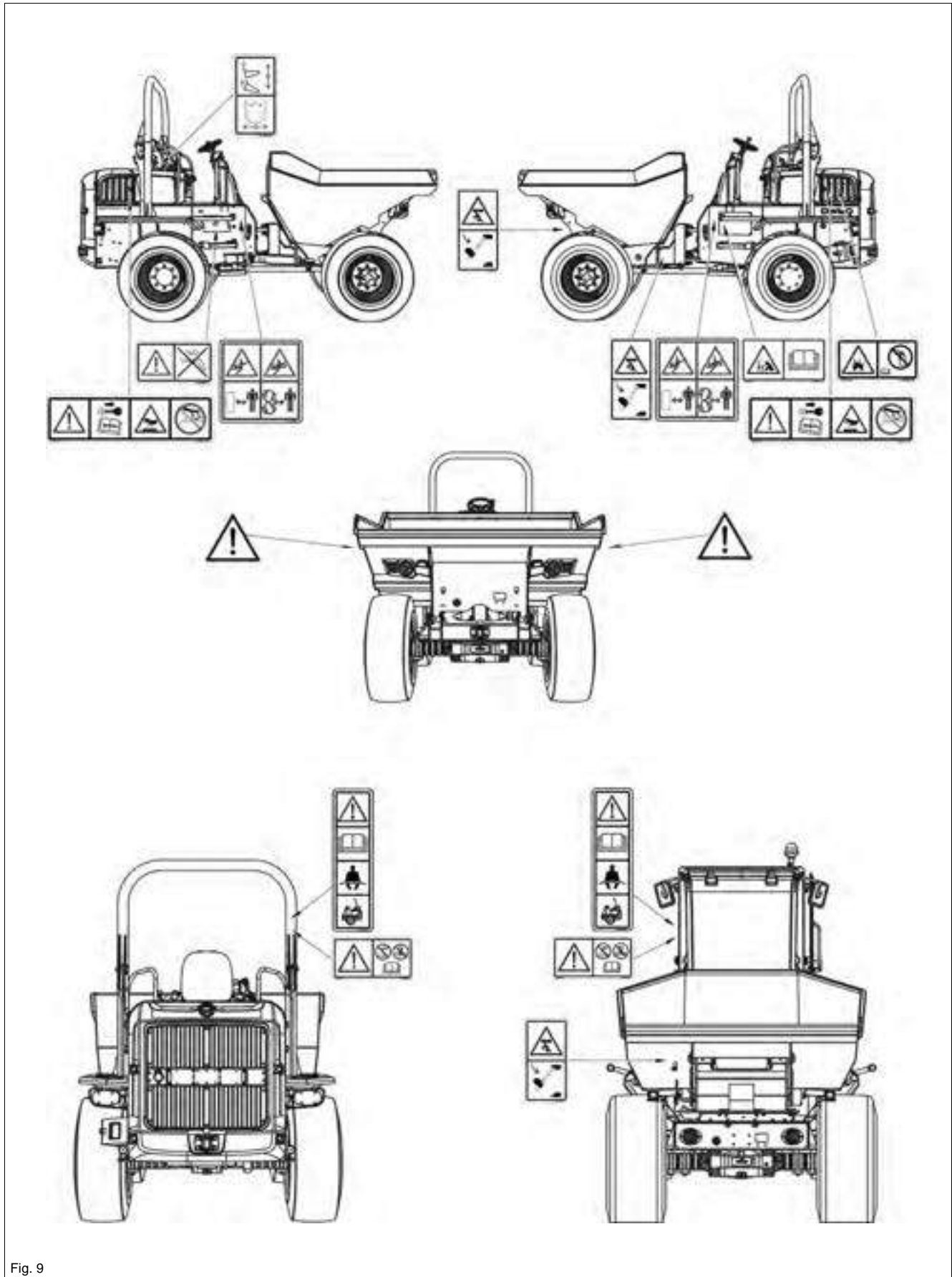

Fig. 9

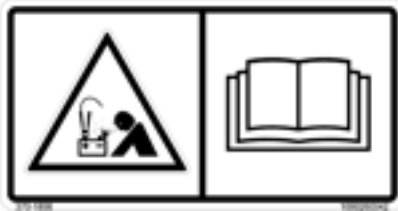

Fig. 10

Meaning

Explosion hazard due to wrong connection of battery jumper cables.
Battery acid is caustic.

Position

Next to the battery.



Fig. 11

Meaning

Modifications to the structure (for example welding, drilling), retrofitting and incorrect repairs affect the protective effect of the cabin or ROPS bar, and can cause serious injury and even death.

Position

On the B pillar (cabin) or on the ROPS bar on the left.

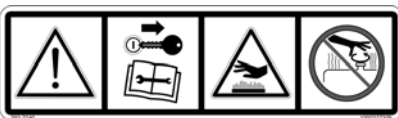

Fig. 12

Meaning

Read the Operator's Manual before starting the machine.

Remove the starting key and carry it with you.

Injury hazard due to rotating parts.

- Open the maintenance flap only at engine standstill.

Burn hazard due to hot parts.

- Let the engine cool down.

Burn hazard due to hot fluid.

Injury hazard due to fluid escaping under pressure.

- Let the engine cool down.
- Release the pressure in the hydraulic system and open the covers carefully.

Position

On the engine cover.

Meaning

Injury hazard due to swiveling or tilting movement of skip.

Position

On the skip on the left and right.



Fig. 13



Fig. 14

Meaning

Maintenance prop/center-pivot prop

Secure the skip before performing maintenance/install the center-pivot prop before lifting the machine.

Position

Near the center-pivot prop and the maintenance prop of the skip.



Fig. 15

Meaning

Do not use starting-aid sprays.

Position

On the outside left of the engine cover.

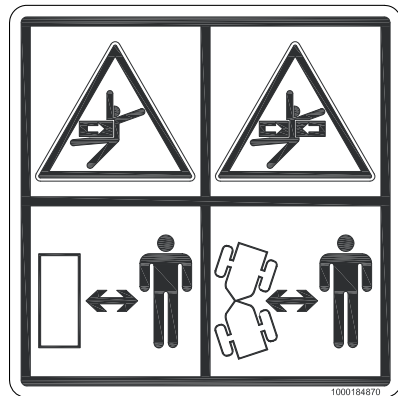

Fig. 16

Meaning

Distance/articulation range

Keep a safe distance from the machine during operation.

Position

On either side of the rear chassis.

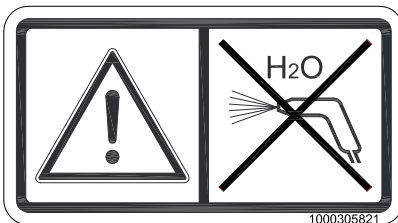

Fig. 17

Meaning

Do not point water jets directly at the cover.

Position

On the fuse box.

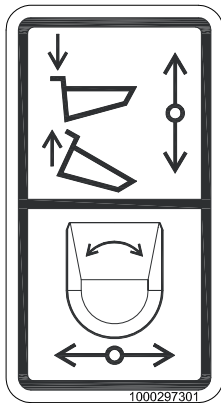

Fig. 18

Meaning

Raising/lowering and turning the skip (swivel skip option)

Position

On the right beside the operator seat.

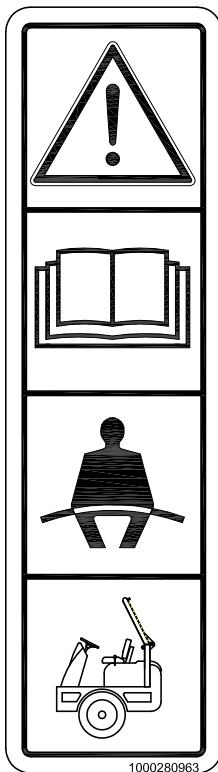

Fig. 19

Meaning

Machine operation is only allowed if the rollbar is raised and locked, and if the seat belt is fastened.

Position

On the B pillar (cabin) or on the ROPS bar on the right.

Information labels

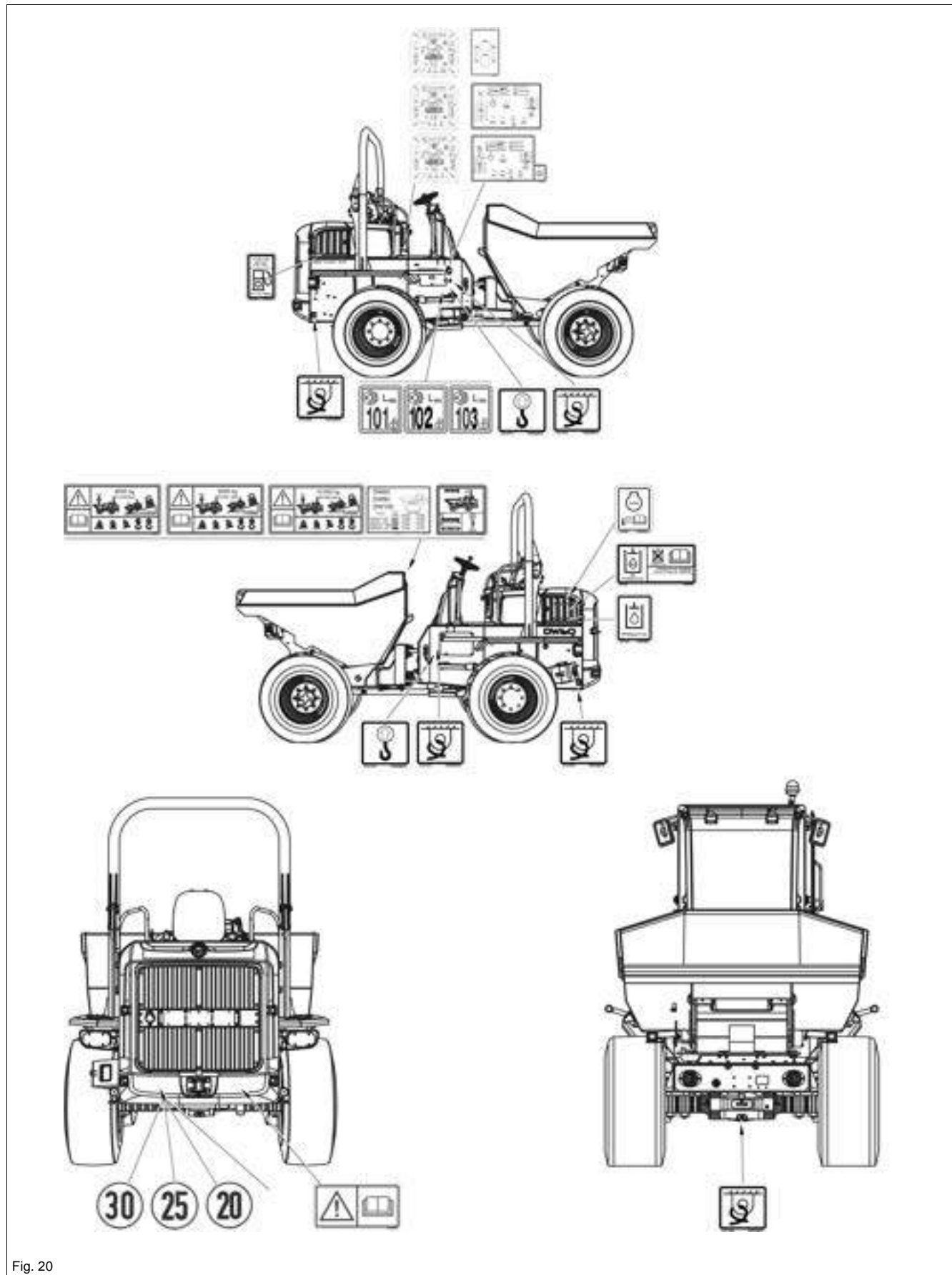

Fig. 20

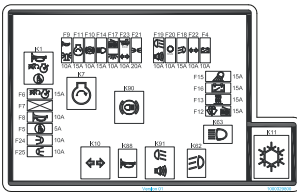

Fig. 21

Meaning

Fuses and relays

Position

Inside the fuse cover.

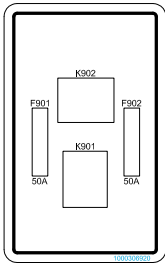

Fig. 22

Meaning

Main fuses and relays

Position

Inside the fuse cover.



Fig. 23

Meaning

Machine lifting points

Position

At the lifting eyes.



Fig. 24

Meaning

Machine tie-down points

Position

At the tie-down points.



Fig. 25

Meaning

Only refuel with diesel fuel with a sulfur content of less than mg/kg (=als15 0.0015 %).

Position

Next to the fuel tank filler inlet.



Fig. 26

Meaning

The reservoir contains hydraulic oil.

Position

Next to the filler inlet of the hydraulic oil reservoir.

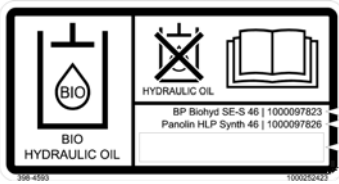

Fig. 27

Meaning (option)

The reservoir contains biodegradable hydraulic oil.
This label is notched on the side depending on the biodegradable hydraulic oil used.

Position

Next to the filler inlet of the hydraulic oil reservoir.



Fig. 28 (symbolic representation)

Meaning

Indication of sound power level produced by the machine.
 L_{WA} = sound power level.

The sound power level depends on the machine.

Position

On the rear frame on the right.

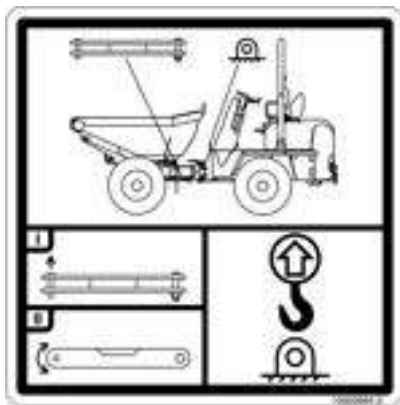

Fig. 29

Meaning

This label explains how to lift the machine with a crane.

Position

At the rear of the skip.

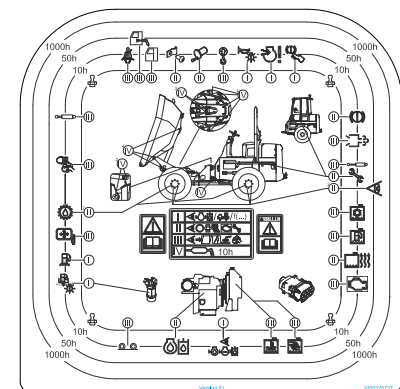

Fig. 30 (symbolic representation)

Meaning

Indication of maintenance intervals.

Position

On the seat console on the right.

Information

The maintenance labels depend on machine equipment and destination country.



Fig. 31 (symbolic representation)

Meaning

Identifies the design-specific machine speed.

Position

At the rear left of the machine and on the machine frame on the left and the right.

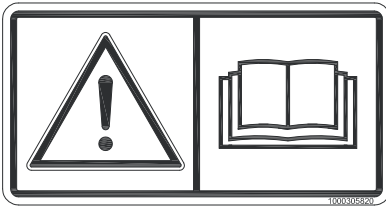

Fig. 32

Meaning

Trailer coupling

Position

On the rear part of the machine on right.

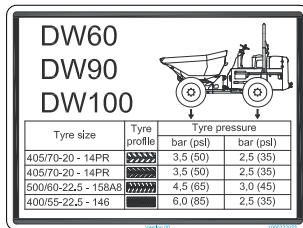

Tyre size	Tyre profile	Tyre pressure	
		bar (psi)	bar (psi)
405/70-20 - 14PR		3,5 (50)	2,5 (35)
405/70-20 - 14PR		3,5 (50)	2,5 (35)
500/60-22,5 - 158A8		4,5 (65)	3,0 (45)
400/55-22,5 - 146		6,0 (85)	2,5 (35)

Fig. 33

Meaning

Tire pressure

Position

At the rear of the skip.

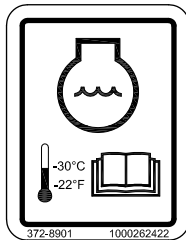

Fig. 34

Meaning

Thermal stability of coolant.

Position

On the radiator in the engine compartment.

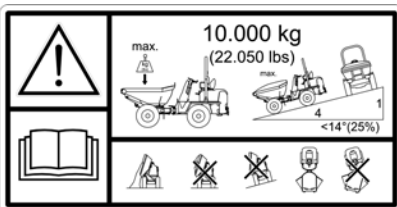

Fig. 35 Symbolic representation

Meaning

This label shows the following information/regulations:

- Maximum payload of machine.
- Tilt out the raised skip only on horizontal ground.
- Tilt out only in straight machine position.
- Maximum slope inclination allowed for tilting out downhill
- Maximum permissible angle of inclination during machine travel across a slope.
- Do not tilt out the skip if material is stuck in the skip.

Position

At the rear of the skip.

ANSI label (option)

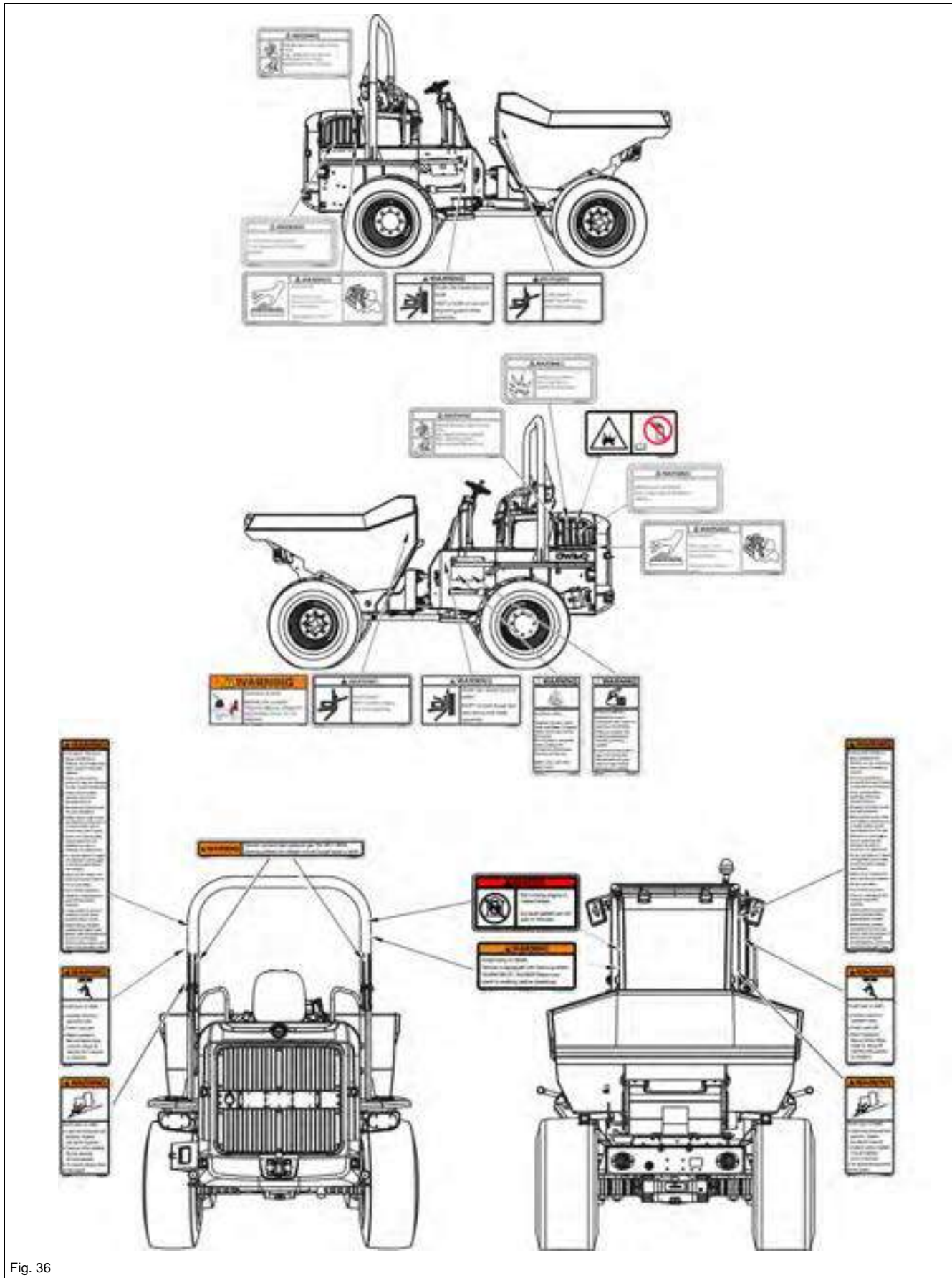

Fig. 36



Fig. 37

Position

On the air filter in the engine compartment.

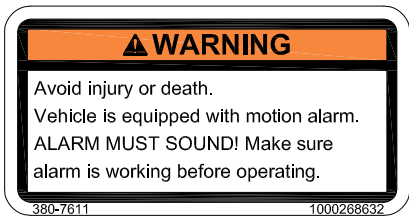

Fig. 38

Position

On the B pillar (cabin) or on the ROPS bar on the right.



Fig. 39

Position

On the air filter in the engine compartment.



Fig. 40

Position

At the rear of the skip.

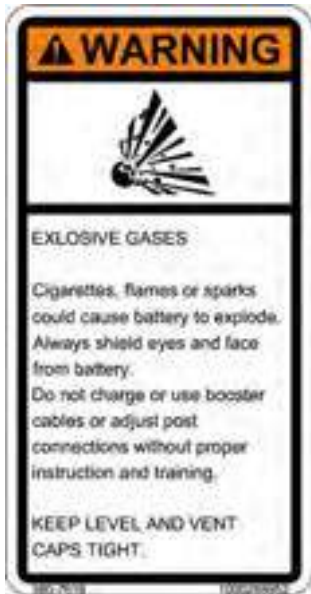

Fig. 41

Position
On the battery cover.



Fig. 42

Position
On the battery cover.



Fig. 43

Position
On the skip on the left and right.

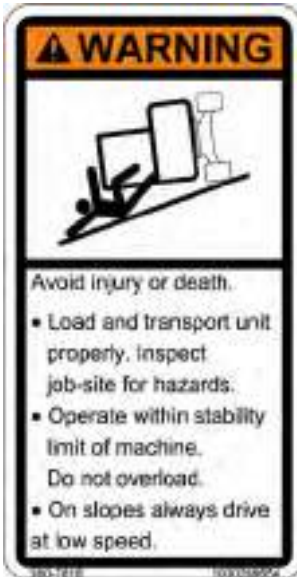

Fig. 44

Position

On the B pillar on the left.



Fig. 45

Position

On the B pillar on the left.



Fig. 46

Position

On the B pillar on the left.



Fig. 47

Position

On the inside of the engine cover.



Fig. 48

Position

On the maintenance flap on the left and right.



Fig. 49

Position

On the maintenance flap on the left.

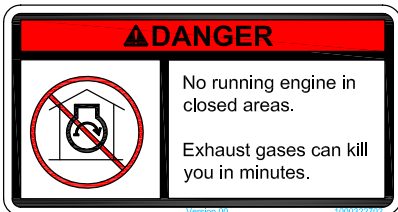

Fig. 50

Position

On the B pillar (cabin) or on the ROPS bar on the right.

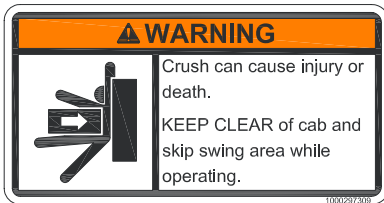

Fig. 51

Position

On the machine frame on the left and right.



Fig. 52

Position

On the ROPS bar.

Notes:

4 Putting into operation

4.1 Cabin/control stand

CAUTION

Injury hazard when entering or exiting!

Entering or exiting incorrectly can cause injury.

- ▶ Keep the mandatory climbing aids **A** and handholds **B** clean and only use them for entering and exiting.
- ▶ Face the machine as you enter and leave it.
- ▶ Have damaged climbing aids replaced immediately. Do not operate the machine.

CAUTION

Crushing hazard due to unlocked cabin door!

Unlocked cabin doors can cause crushing.

- ▶ Lock the cabin door.
- ▶ Use the handholds for closing.

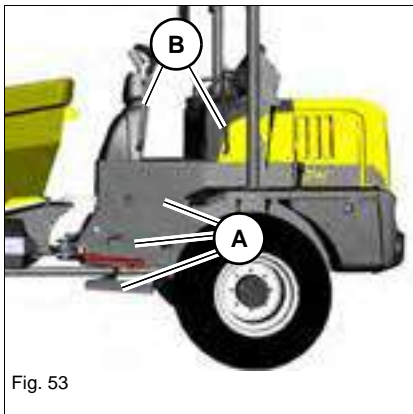

Entry and exit

Use the climbing aids **A** and handholds **B**, and do not hold onto the control elements.

Entry and exit is possible on either side.

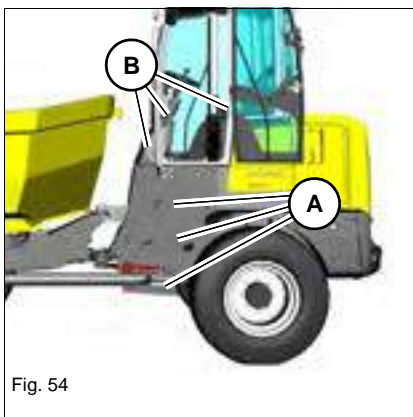

Cabin entry and exit (option)

Use climbing aid **A** and handholds **B**, and do not hold onto the control elements.

Entry and exit is possible on either side.

Information

When entering or leaving the cabin, the door must be locked in the arrester.

Unlocking and locking the door (option)

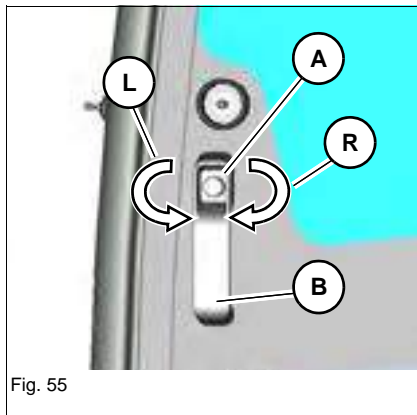

Fig. 55

Both cabin doors are equipped with locks.

Unlocking

Turn the starting key in door lock **A** anticlockwise (**L**).

Lock

Turn the starting key in door lock **A** clockwise (**R**).

Opening the door

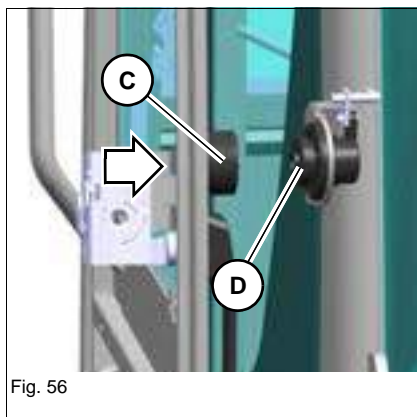

Fig. 56

Outside

Press door lock **A** and pull handle **B**. To keep the door in the open position, let door arrester **C** engage in lock **D**.

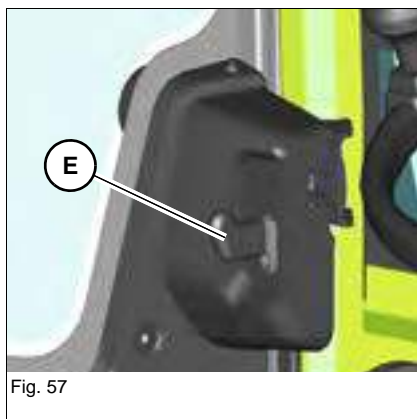

Fig. 57

Inside

Press lever **E** on the door lock downward.

Closing the door

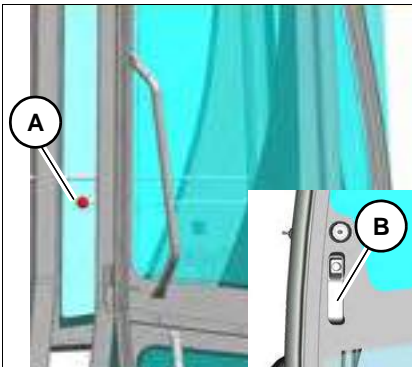

Fig. 58

Outside

Release the door from the arrester by pressing ball handle **A** and closing it with handle **B** outside until it engages.

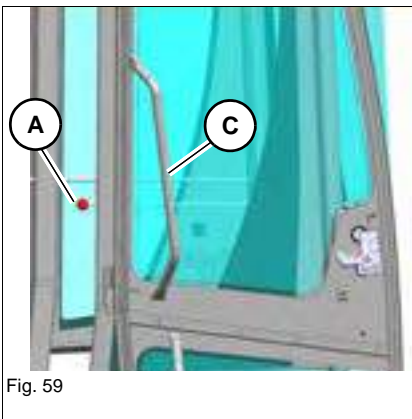

Fig. 59

Inside

Release the door from the arrester by pressing ball handle **A** and close it with handle **C** until it engages.

Opening the door to a gap

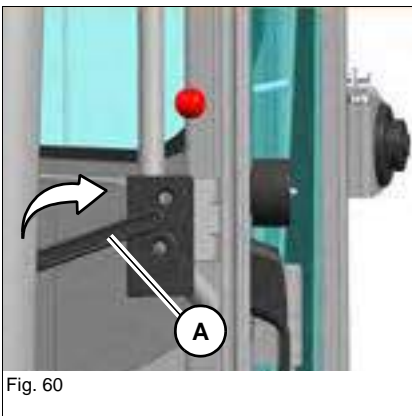

Fig. 60

The door can be opened to a gap during machine operation with the door arresters at the front left and right in the cabin.

1. Turn door opener **A** outward.
2. Let the door engage in door arrester **A**.
 - ➔ The door is opened to a gap during machine operation.

Emergency exit

The cabin has doors on the left and right. One side can therefore always be used as an exit in case of an emergency.

Seat adjustment

WARNING

Accident hazard due to seat adjustment during machine operation!

Adjusting the operator seat during machine operation can cause serious injury or death.

- ▶ Adjust the operator seat before putting the machine into operation.
 - ▶ Ensure that the levers are locked into place.
-

WARNING

Spinal cord injury due to incorrect seat adjustment!

An incorrect weight adjustment can cause injury to the spinal cord.

- ▶ Ensure that the seat is correctly adjusted to the operator's weight before machine travel or operation.
 - ▶ Machine operation is prohibited for operators weighing less than 50 kg (110 lbs) or more than 140 kg (309 lbs).
-

Information

The operator seat can be fitted with an optional operator presence switch. The traveling drive shifts to neutral as soon as the operator is not seated for more than 25 seconds.

Functional check of operator presence switch (option)

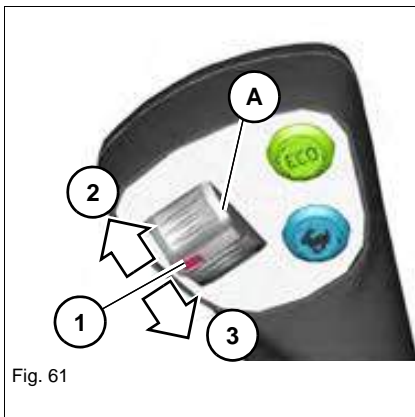

Perform a functional check once a day.

1. Start the machine.
2. Sit down on the operator seat.
3. Put slide switch **A** in position **2** or **3** and check whether machine travel starts.
4. Remove the weight off the operator seat for at least five seconds.
5. Carefully bring slide switch **A** to position **2** or **3**.
 - ▶ The machine must not start moving.

Contact a Wacker Neuson service center immediately if the machine starts.

Operator seat

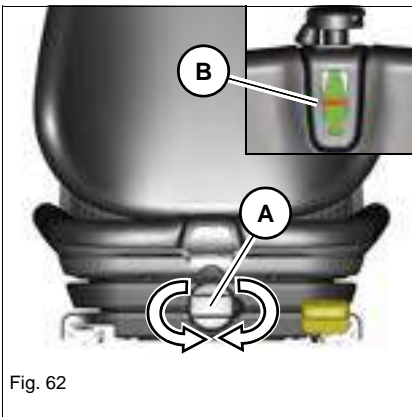

Fig. 62

Adjusting the weight

1. Sit down on the operator seat.
2. Fold out and turn crank **A** until the red scale is in the middle of indicating instrument **B** (on the seat surface).

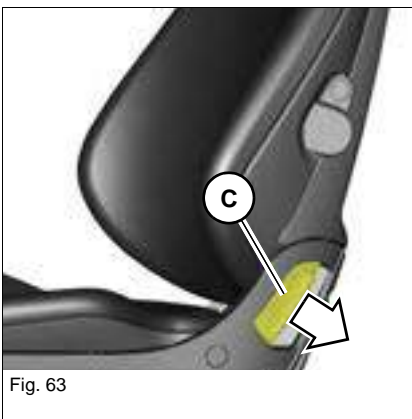

Fig. 63

Adjusting the backrest

1. Sit down on the operator seat.
2. Push handle **C** in the direction of the arrow and move the backrest to the required position at the same time.
3. Release handle **C**.

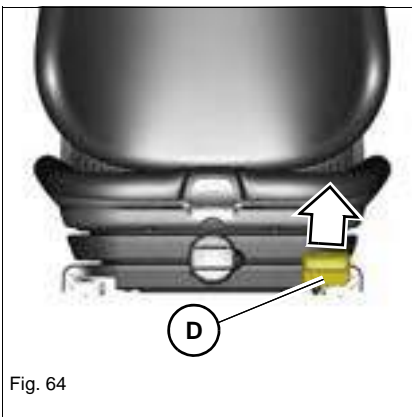

Fig. 64

Horizontal adjustment

1. Sit down on the operator seat.
2. Pull handle **D** upward and at the same time lock the seat in the required position.

Retracting seat belt

WARNING

Injury hazard if the seat belt is not fastened correctly or not at all!

Fastening the seat belt incorrectly, or not at all, can cause serious injury or death.

- ▶ Firmly fasten your seat belt over your hips before starting machine operation.
 - ▶ Do not fasten a twisted seat belt, and do not place it over hard, edged or fragile items in your clothes.
 - ▶ Ensure that the buckle is inserted (pull test).
 - ▶ Do not use seat belt extensions.
-

WARNING

Injury hazard due to damaged or dirty seat belt!

A damaged or dirty seat belt can cause serious injury or death.

- ▶ Keep the seat belt and buckle clean, and check them for damage.
 - ▶ Have a damaged seat belt and buckle immediately replaced by a Wacker Neuson service center.
 - ▶ Have the seat belt immediately replaced after every accident and the bearing capacity of the fastening points and seat fixtures checked by a Wacker Neuson service center.
-

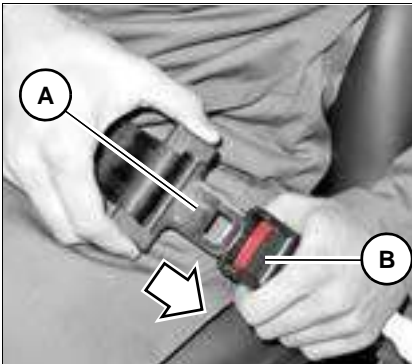

Fig. 65

Fastening the seat belt

Insert buckle latch **A** into seat belt buckle **B** until it engages.

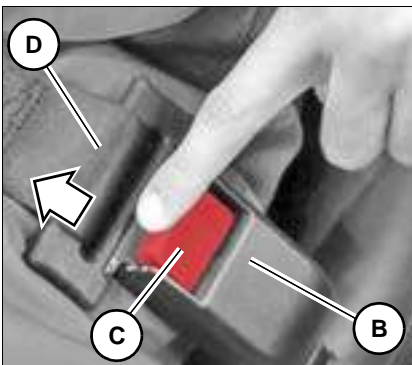

Fig. 66

Unfastening the seat belt

Press the red push button switch **C** on seat belt buckle **B** until the buckle latch comes out.

➤ Seat belt **D** is automatically retracted.

Adjusting the mirrors (option)

WARNING
Injury hazard to persons in the danger zone!

Persons in the danger zone are possibly not seen when reversing the machine. This can cause accidents with serious injuries or death.

- ▶ Adjust the existing visual aids (for example the rearview mirrors) correctly.
- ▶ Interrupt work immediately if persons enter the danger zone.
- ▶ Pay attention to the movements and changing positions of persons.

WARNING
Accident hazard due to restricted field of vision on the job site!

Accidents resulting in serious injury or death can be caused by a restricted field of vision.

- ▶ Do not allow anyone to stay in the danger zone.
- ▶ Use suitable visual aids if necessary (for example a camera, mirrors, guide).
- ▶ Additional equipment must not be installed if it impairs visibility.

WARNING

Accident hazard due to incorrect adjustment of visual aids!

Incorrectly adjusted visual aids can cause serious injury or death.

- ▶ Before starting work, ensure that all visual aids are clean, functional and adjusted in accordance with the instructions in this Operator's Manual.
- ▶ Immediately replace damaged or broken visual aids.
- ▶ Curved mirrors enlarge, reduce or distort the field of view.
- ▶ The operator must follow the national and regional regulations.

- Use safety-oriented ladders and work platforms for adjustment work on the machine.
- Do not use machine components as a climbing aid.
- Set the skip to travel position before adjusting the mirrors.

Adjusting the outside rearview mirrors on left and right

- Ensure sufficient visibility from the operator seat onto the job site.
- Ensure maximum visibility to the rear.
- Ensure visibility of the rear left edge of the machine in the mirror on the left.
- Ensure visibility of the rear right edge of the machine in the mirror on the right.

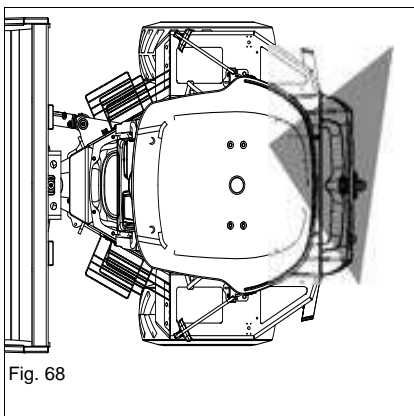
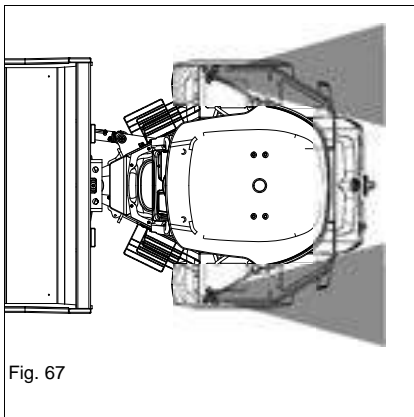

Adjusting the inside mirror

- Ensure sufficient visibility from the operator seat onto the job site.

Camera (option)

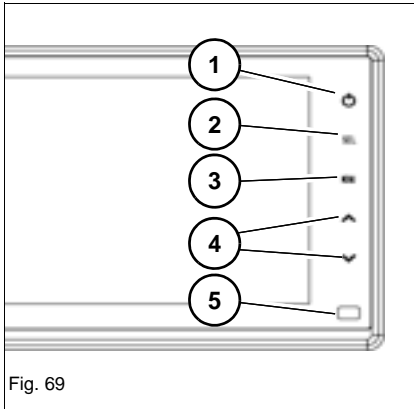

Fig. 69

The camera display is protected with a transparent flap. Raise the flap to operate the display.

1. ON/OFF switch
2. SEL
For selecting pages in the menu.
3. Menu
For activating the menu. The menu list is hidden after seven seconds if no selection is made.
4. Buttons
For modifying a value.
5. Day/night sensor
Automatic brightness adjustment

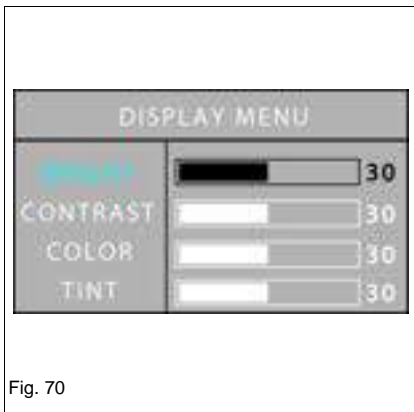

Fig. 70

Setting the display

The following settings can be made:

- Brightness
 - Contrast
 - Color
 - Color
1. Press the **Menu** button.
 2. Select the required setting with the buttons.
 3. Press the **SEL** button.
 4. Select the required setting with the buttons.
 5. Confirm with the **SEL** button.
 6. Press the **menu** button to exit the settings menu.

Setup menu – adjusting the camera

The camera is preset at the factory. For additional details contact a Wacker Neuson service center.

Visual range

The camera has a vertical visual range of 66°.

The camera has a horizontal visual range of 88°.



Information

The camera's field of vision is restricted if the skip is tilted.

Fire extinguisher



Fig. 71

A fire extinguisher is not available from Wacker Neuson.

Contact a Wacker Neuson service center for the installation of a fire extinguisher (NFPA).



Information

Ensure that the fire extinguisher is firmly fastened during machine operation. Inspect the holder and the fire extinguisher regularly. Observe the manufacturer's indications.

Protective structures

Protective structures are additional elements that protect the operator against hazards. These elements can be installed later on or as standard equipment.

DANGER

Accident hazard due to modified cabin or protective structures!

Modifications (for example drilling) weaken the structure and causes serious injury or death.

- ▶ No drilling, cutting or grinding.
 - ▶ Do not install any brackets.
 - ▶ No welding, straightening or bending.
 - ▶ Replace the complete protective structure if it is damaged, deformed or cracked.
 - ▶ Contact a Wacker Neuson service center in case of doubt.
 - ▶ Retrofit, assembly and repair work may only be performed by a Wacker Neuson service center.
 - ▶ Replace self-locking fasteners.
 - ▶ Screws to which an adhesive has been applied must be cleaned with a suitable cleanser before they are re-used.
-

Information

Machine operation is only allowed with a correctly installed and intact rollbar or correctly installed and intact cabin.

For additional protection, only use correctly installed and intact Wacker Neuson protective structures that have been released for the machine.

Responsibility for machine equipped with protective structures

The decision regarding the necessary protective structures (type and level I or II) must be made by the company/person operating the machine and depends on the specific work situation.

The operating company of the machine must observe the national regulations and he must inform the operator on the protective structure to be used in a specific work situation.

FOPS level II cabin (option)



DANGER

Crushing hazard due to falling objects!

Causes serious injury or death.

- ▶ Install a protective FOPS structure in areas with danger of falling objects.
-



Information

The cabin complies with the FOPS level II requirements according to EN ISO 3449:2008

- ▶ The machine owner must ensure that the hazard situation is evaluated and that the national regulations are observed.
 - ▶ The machine owner must ensure that only work is performed that does not require any higher protection.
 - ▶ Accidents cannot be fully avoided despite equipping a machine with protective structures.
-

Rollbar

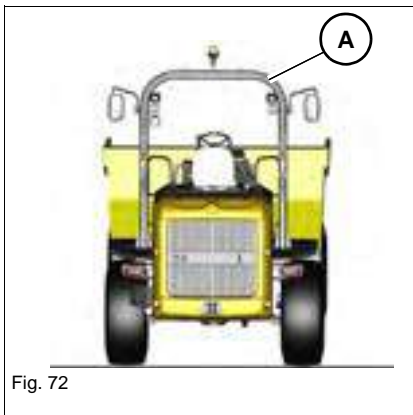

Rollbar **A** is included in the machine's standard equipment.

DANGER

Accident hazard due to falling objects!

Causes serious injury or death.

- ▶ Machine operation is only allowed if the rollbar is raised and locked, and if the seat belt is fastened.
- ▶ Wear protective equipment (for example protective clothing, safety glasses).
- ▶ Operation in areas involving a risk of falling objects is prohibited.
- ▶ Operation in areas with fragments flying around is prohibited.

Machine travel with a lowered rollbar

In case of a low clearance height, the rollbar can be lowered if machine travel is limited to a short distance through a passage.

DANGER

Accident hazard during machine operation with a lowered rollbar!

Can cause serious injury or death.

- ▶ Perform machine travel only on absolutely level ground.
- ▶ Do *not* fasten the seat belt in order to be able to leave the machine immediately in an emergency.
- ▶ Wear protective equipment (for example protective clothing, safety glasses).

However, the following conditions must be fulfilled:

- Obtain the approval of the appropriate national authority.
- Working with a lowered rollbar is prohibited under all circumstances.
- The machine must make no tipping movement.

Information

The rollbar weight is about 100 kg (220 lb) depending on the model. A gas strut is installed to support raising and lowering. However, in spite of the rollbar being equipped with a gas strut, only lower it with two qualified persons from the side of the machine.

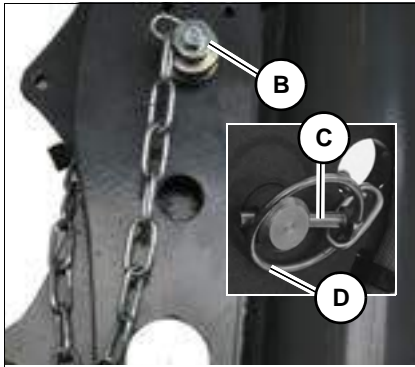

Fig. 73

Lowering the rollbar

1. Park the machine on level ground.
2. Raise ring **D**.
3. Remove split pin **C** from lock pin **B**.
4. Remove lock pin **B**.
5. Slowly lower rollbar **A** with the help of a second qualified person from the side of the machine.

Raising the rollbar

1. Park the machine on level ground.
2. Raise the rollbar with the help of a second qualified person.
3. Secure the rollbar with lock pins **B**.
4. Secure lock pins **B** with split pins **C**.
5. Lower ring **D**.

Sun visor (option)

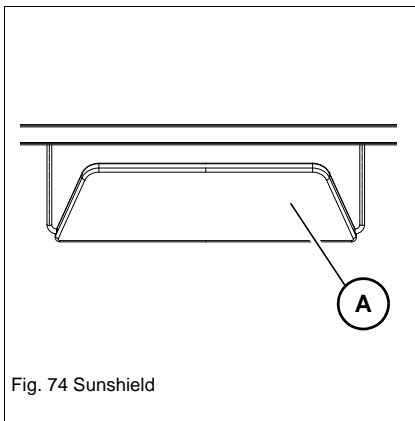

Fig. 74 Sunshield

The sun visor can increase road safety. It is located at the upper edge of the cabin. Fold down the sun visor as required. Adjust the sun visor so that the machine travel and operating range is not covered.

Sunshield (option)

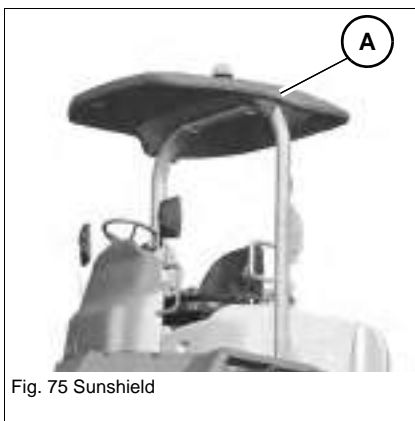

Fig. 75 Sunshield

Sunshield **A** protects against excessive sun.



Information

Do not remove protection **B** if a sunshield is installed. It prevents the sunshield from hitting the engine cover when the rollbar is lowered.

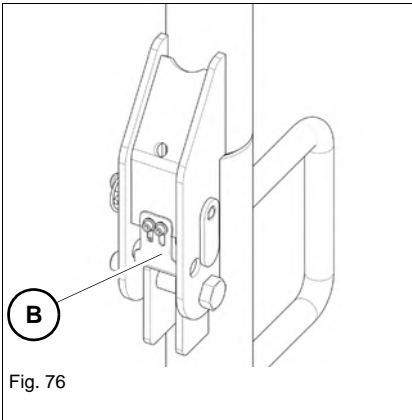

Protection (on left and right of rollbar).

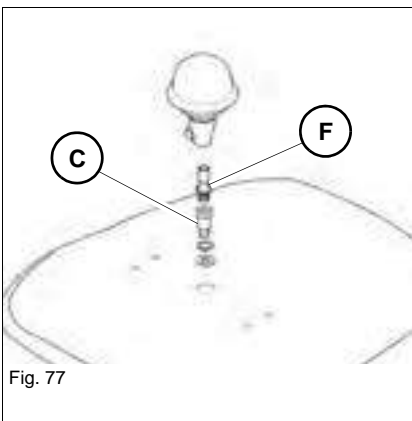

Assembly:

Install the sunshield with at least two qualified persons.

1. Remove the rotating beacon.
2. Route the cable for the rotating beacon through the opening in the roof.

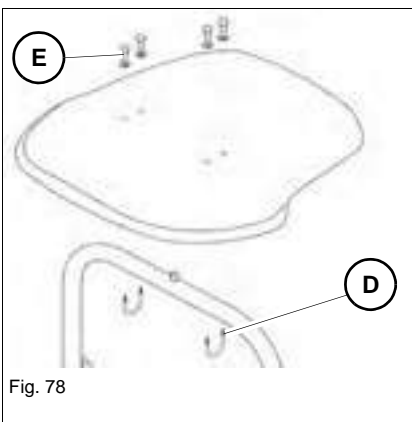

3. Insert the assembly brackets **D** through the openings in the roof and tighten screws **E** to 87 Nm (64 ft.lbs).
4. Insert extensions **C** through the openings in the roof and tighten them to 130 Nm (96 ft.lbs) on the rollbar.
5. Tighten bracket **F** on extension **C**.
6. Install the rotating beacon.

Skip grid (option)

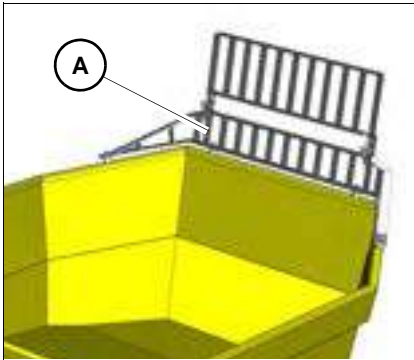

Fig. 79 Symbolic representation

Skip grid **A** protects the cabin and the operator's compartment against falling material or against an excavator bucket penetrating the cabin during loading.

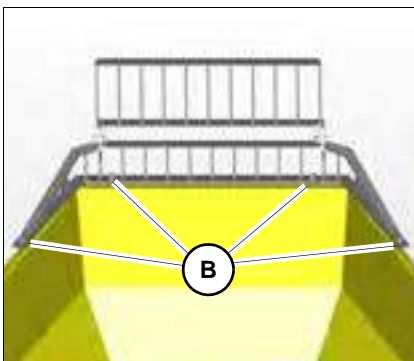

Fig. 80

Assembly:

Skips delivered from quarter 4/2015 have a threaded fitting for fastening the skip grid with screws.

1. Stop and park the machine. Stop the engine – see *“Preparing lubrication” on page 7-8.*
2. Put the skip grid on the assembly points with at least two persons. Use suitable external climbing aids.
3. Tighten the four screws **B** to 410 Nm (302 ft.lbs).

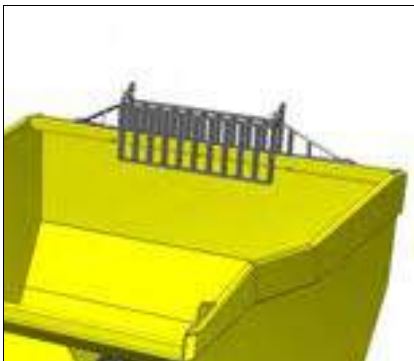

Fig. 81

Lowering/raising the skip grid

The skip grid must be lowered during machine travel on public roads.

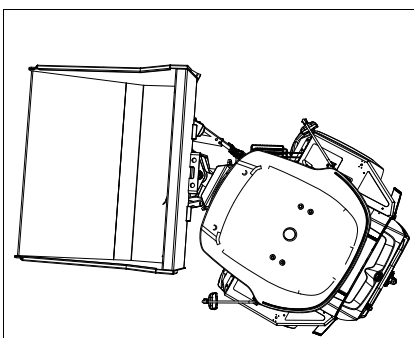
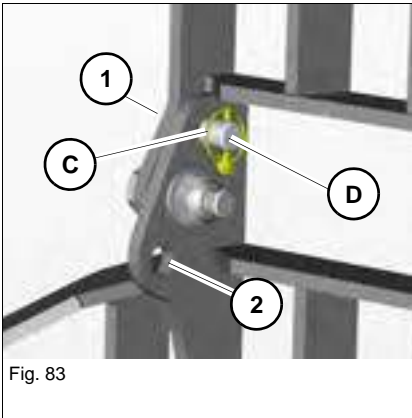

Fig. 82

1. Steer the machine as shown in *Fig. 82.* Stop the engine.
2. Remove split pin **C** from pin **D** on the side with the smaller angle.
3. Remove it from the hole
4. Lower the grid.
5. Insert pins **D** in the holes and secure them with split pin **C**.
6. Steer the machine to the other side.
7. Perform steps 2 to 5 on the side with the smaller angle.



Function	Position
Raise	Insert and secure the pin in hole 1
Lower	Insert and secure the pin in hole 2

Document box

The Operator's Manual is stored in the document box under the seat.

12 V connection

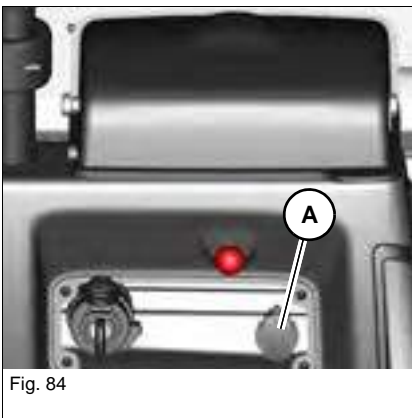

A 12 V power outlet **A** is located beside the starter.

4.2 Overview of control elements

This chapter describes the controls, and contains information on the function and handling of the indicator lights and controls.

The pages stated in the table refer to the description of the controls.

Control stand

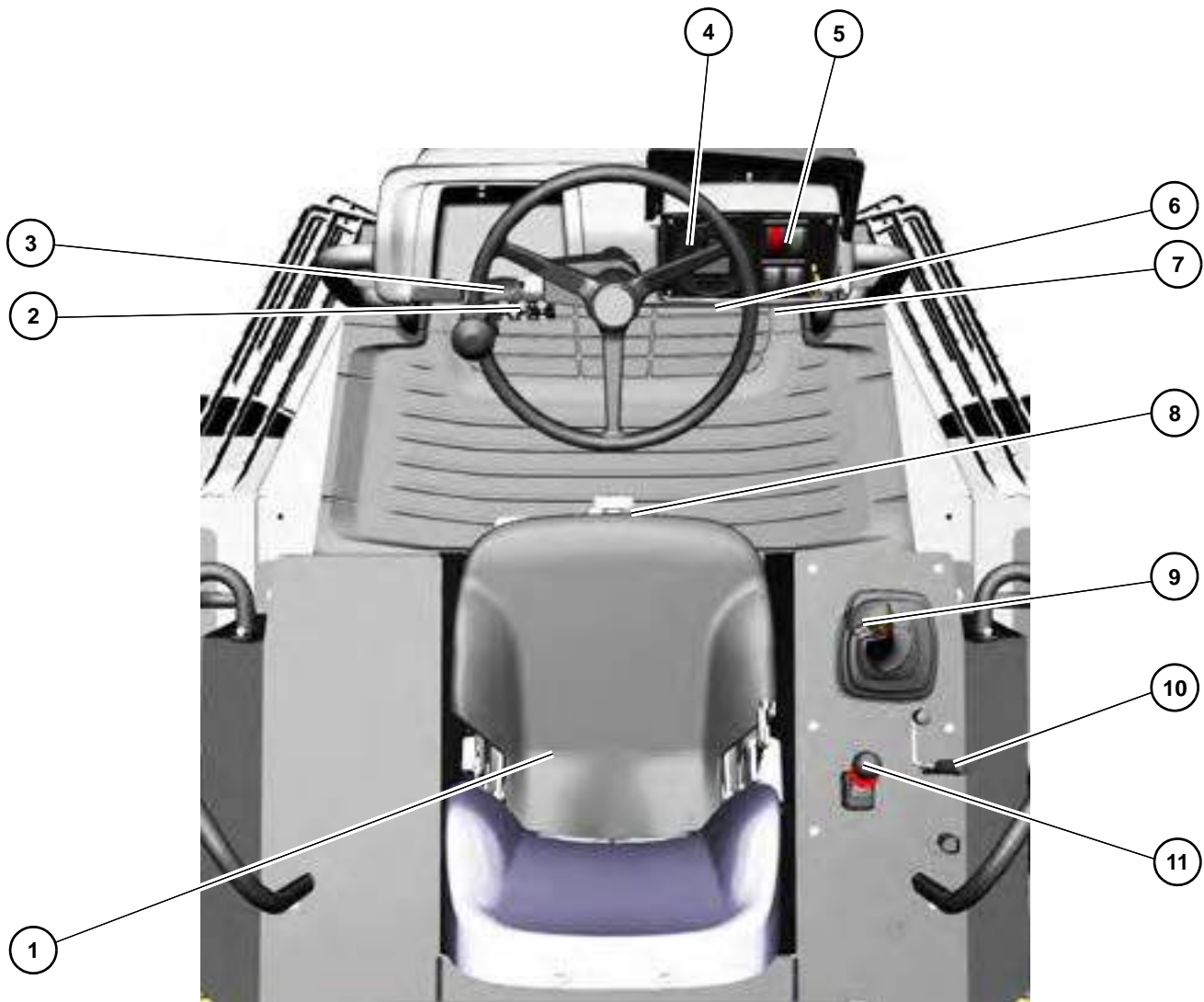

Fig. 85 Overview of control elements

Designation	See page
1 Operator seat and seat belt	4-4; 4-6
2 Service brake	5-4
3 Steering-column lever (option for Austrian road traffic regulations StVZO)	4-22
4 Display element	4-24
5 Switch panel	4-22
6 Accelerator pedal	5-3
7 12 V connection	4-17
8 Document box	4-17
9 Control lever	5-3
10 Operating hydraulics lock lever	5-10
11 Parking brake	5-4

Cabin (option)

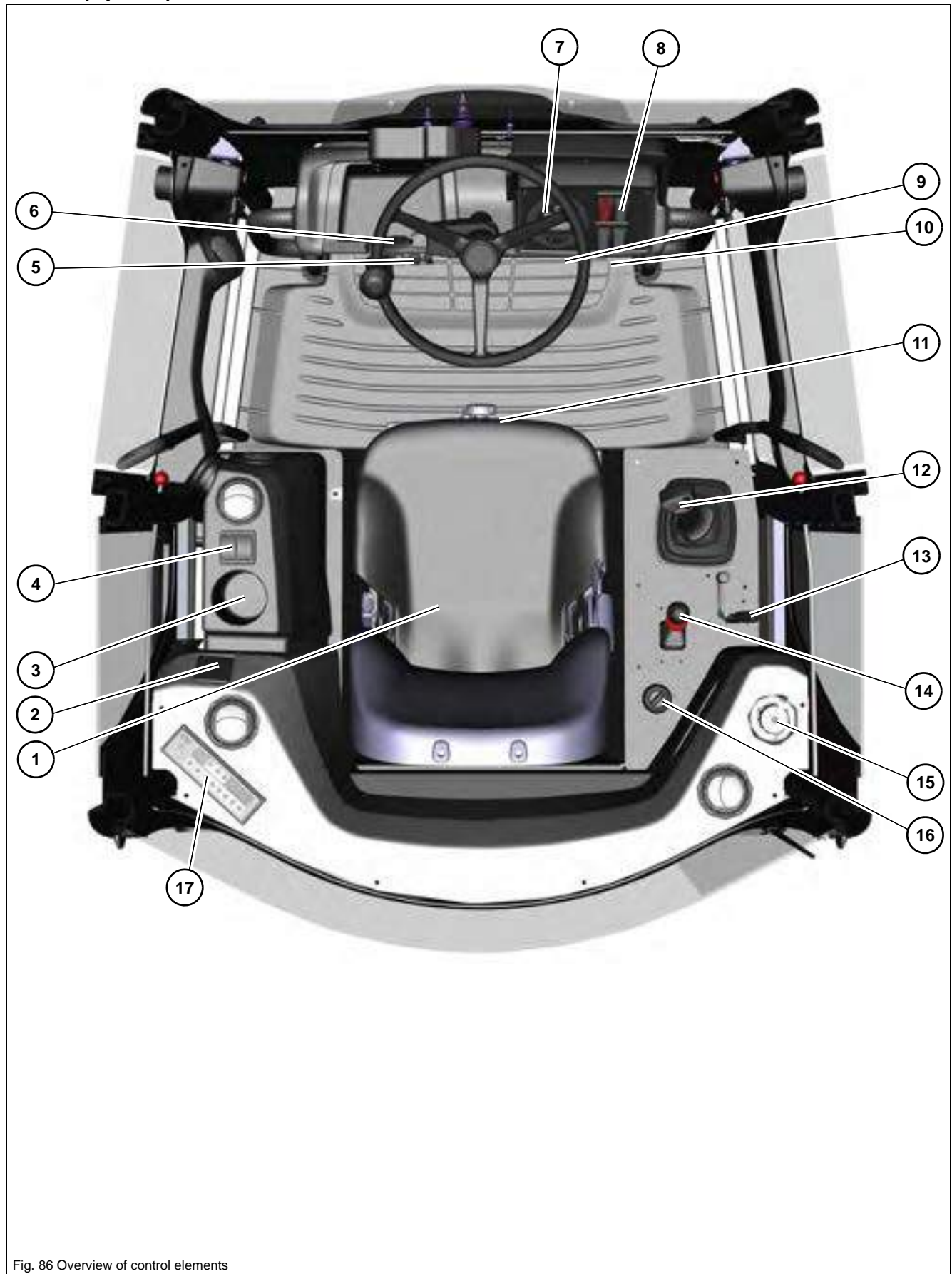

Fig. 86 Overview of control elements

Designation	See page
1 Operator seat and seat belt	4-4; 4-6
2 Rear left switch panel (option)	4-22
3 Drinks holder	--
4 Switch panel on left (option)	4-22
5 Service brake	5-4
6 Steering-column lever (option for Austrian road traffic regulations StVZO)	4-22
7 Display element	4-24
8 Switch panel	4-22
9 Accelerator pedal	5-3
10 12 V connection	4-17
11 Document box	4-17
12 Control lever	5-3
13 Operating hydraulics lock lever	5-10
14 Parking brake	5-4
15 Washer fluid reservoir (cabin option)	5-20
16 Temperature controller (cabin option)	5-21
17 Radio (option)	--

Control elements and switches

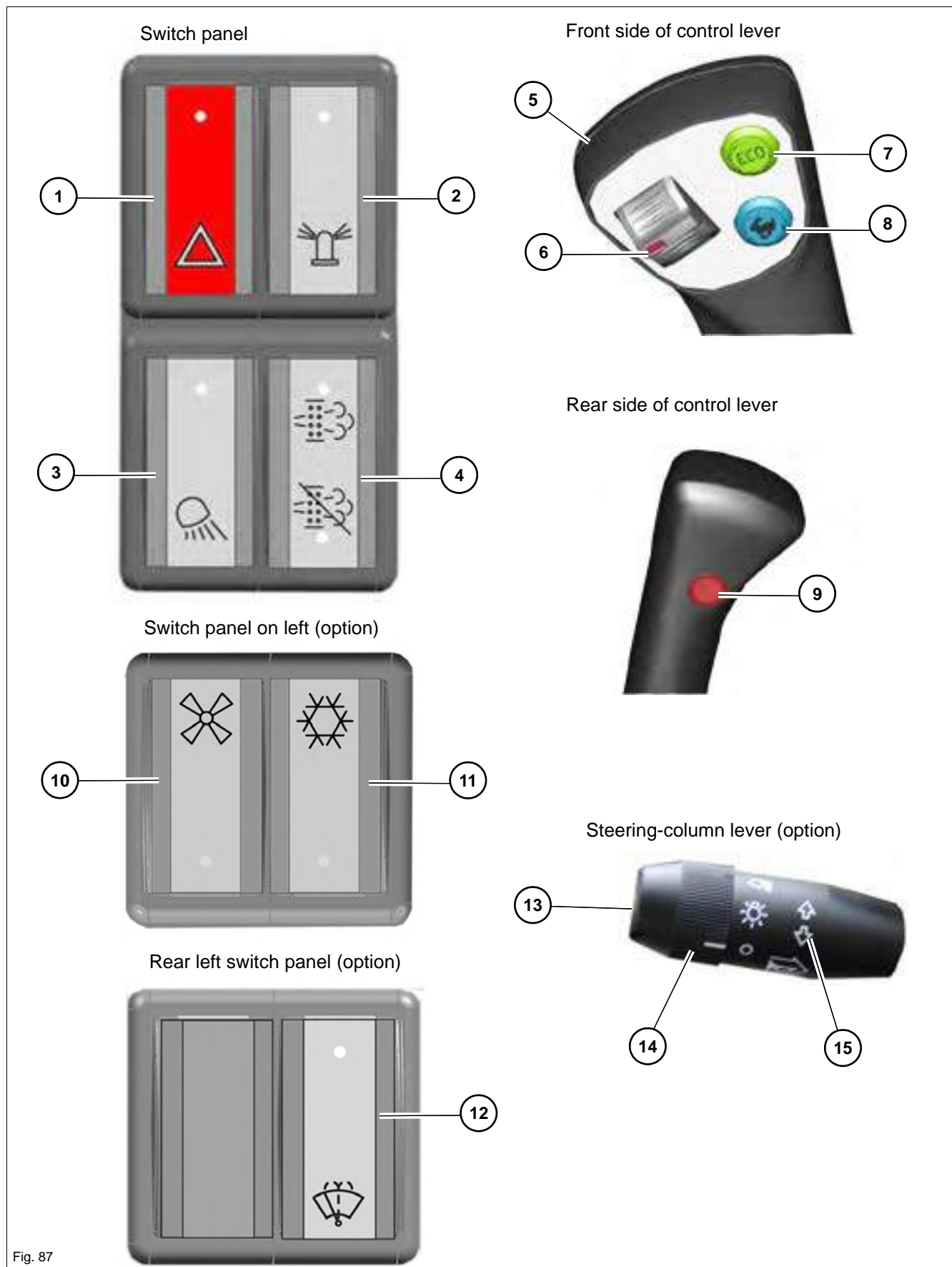

Fig. 87

Designation	See page
1 Hazard warning system (option)	5-19
2 Rotating beacon (option)	5-18
3 Working lights (option)	5-16
4 Particulate matter catalyst (Tier IV engine only)	7-42
5 Operating hydraulics	5-22
6 Selection of travel direction	5-11
7 Eco push button	5-3
8 Speed changeover (no function for DW 60)	5-3
9 Horn	5-18
10 Ventilation (option)	5-21
11 Air conditioning (option)	5-21
12 Wiper/wash system (option)	5-20
13 Horn (option)	5-18
14 Road travel lights (option)	5-17
15 Turn indicators (option)	5-19

4.3 Indicator lights and warning lights (overview)









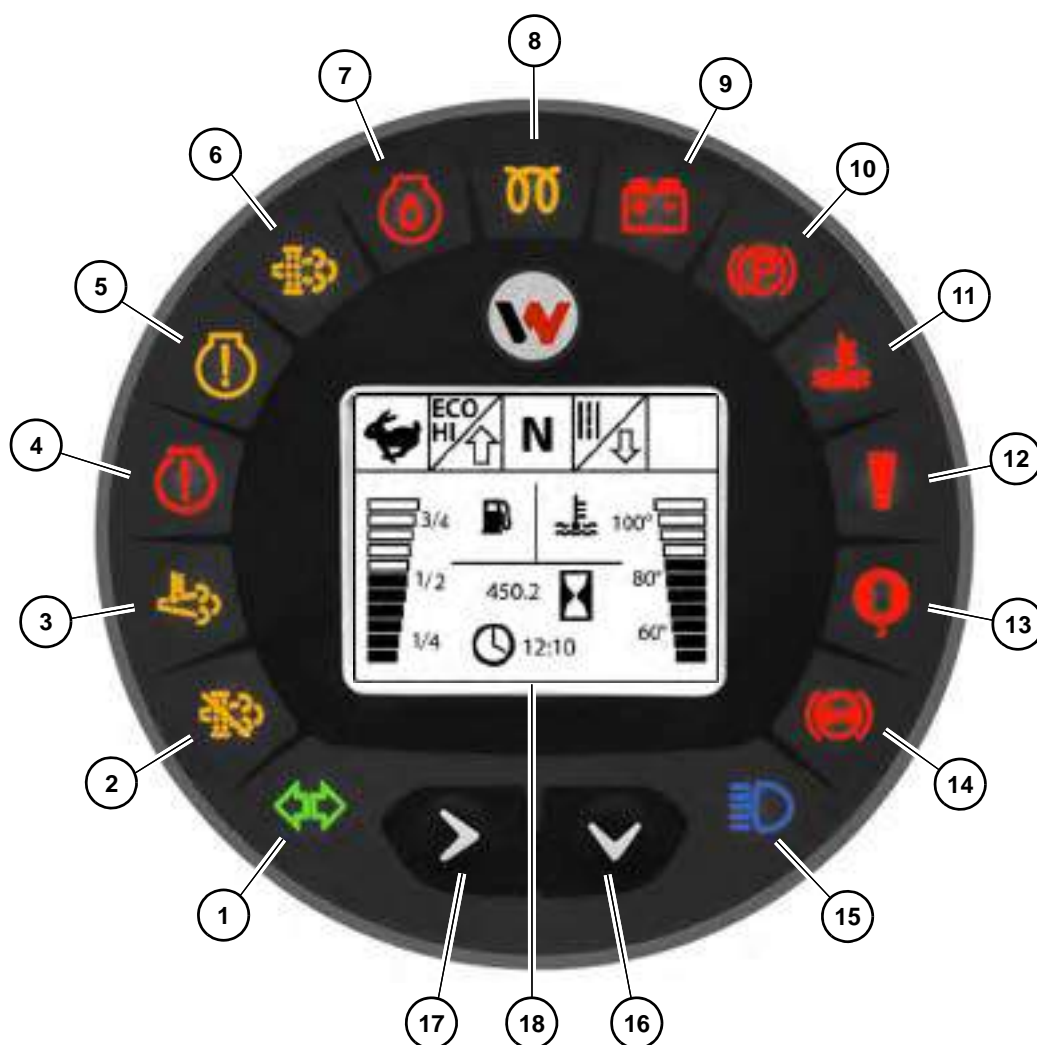









Display element

The display element and the multifunctional display informs the operator of the operating states, required maintenance or possible machine malfunctions.













i **Information**

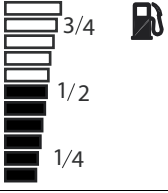
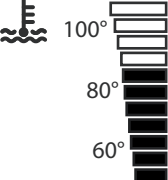









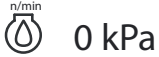



After switching on the starter, the indicator lights are checked during the first 2 seconds and the current reading of the maintenance meter is displayed. Then the operating hours are automatically displayed.

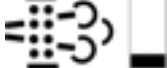

No.	Symbol	Color	Designation	See
1		Green	Turn indicators Flashes when the steering-column lever is actuated	5-19
2		Yellow	PCM regeneration disabled/interrupted	7-42
3		Yellow	High exhaust-gas temperatures	7-42
4		Red	Engine stop	8-1, 8-2, 7-48
5		Yellow	Engine warning	8-1, 8-2, 7-48
6		Yellow	PCM regeneration	7-42
7		Red	Engine oil pressure	8-2
8		Yellow	Preheating	4-35
9		Red	Charge indicator light	8-2
10		Red	Parking brake	5-4
11		Red	Coolant temperature	8-2 8-4
12		Red	General malfunction	8-2
13		Red	(not assigned)	--
14		Red	(not assigned)	--
15		Blue	High beam (Austrian road traffic regulation StVZO option)	--
16		---	Selector button (multifunctional display)	5-7
17		---	To next menu page/set (multifunctional display)	5-7
18		---	Multifunctional display	5-3, 5-6,8-2, 8-4

Meaning of displays and symbols

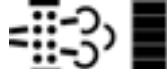
Symbol	Designation	Page
	Speed range 1	5-3
	Speed range 2 (DW90/100 only)	
450.2 	Hour meter	4-28
49.8 	Operating hours to next maintenance	
 12:10	Time	5-7
800 rpm	Engine speed	
	Fuel tank capacity	4-28
	Coolant temperature	8-2; 8-4
	Engine error	8-6
 ECU	Machine error	
	Engine data	--
 ECU	Machine data	--
	Particulate matter catalyst (without exclamation mark from software version 3.3)	7-42; 8-6
	No malfunction	--
 35 °C	Detailed coolant temperature	--
 800 rpm	Detailed engine speed	--

Symbol	Designation	Page
	Detailed engine oil pressure	--
	Engine number	--
	Setting of display brightness	5-7
	Setting of display contrast	
	Setting of time/date	
	Pilot control pressure	
	Replace the hydraulic oil filter	8-2
	Dirty air filter	
	Dirty hydraulic oil radiator	
	Charge indicator light	
	PCM: low load	
	PCM: medium load	
	PCM: highest load	
	Symbol flashes: PCM regeneration required	
	Symbol illuminates: PCM regeneration active	

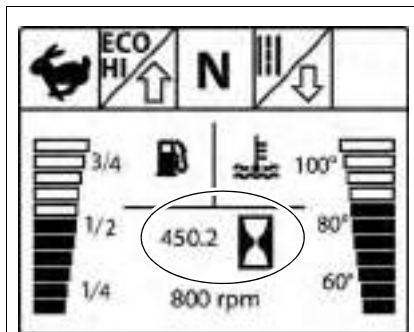

Fig. 88

Hour meter

Counts the engine operating hours with the engine running.

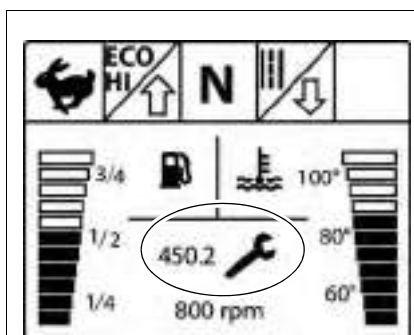

Fig. 89

Maintenance meter

Counts the engine operating hours until the next maintenance.

The maintenance meter starts at 500.0 hours. It counts down to 0.0 hours. The wrench symbol then starts to flash.

The maintenance meter keeps on counting down (-0.1 hours, -0.2 hours, etc.)

Information

After 500 operating hours the output of the Tier IV diesel engine is reduced by 25 % if maintenance is not performed.

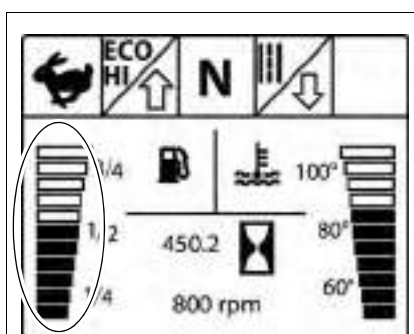

Fig. 90

Fuel level indicator

Indicates the remaining amount of fuel in the tank.

Refuel if the segments reach the low range.

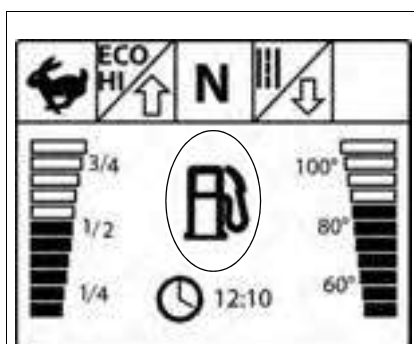

Fig. 91

Add fuel if the highlighted symbol appears in the main menu.

4.4 Preparatory work

Important information before putting the machine into operation

Perform a visual check before starting work:

- There must be no leaks.
- There must be no damaged or loose parts.
- Do not allow anyone to stay in the danger zone.

Before putting the machine into operation, the operator must familiarize himself with the position of the controls and instruments.

Only operate the machine from the seat with the seat belt fastened.

Before using the machine in work operation for the first time, Wacker Neuson recommends trying out the machine on open ground without any obstacles.

When using the machine, check the surroundings constantly in order to identify potential hazards in time.

Before starting work or when changing operators, ensure that all visual aids (for example the mirrors) work correctly, that they are clean and adjusted in accordance with the instructions in this Operator's Manual.

The operator must follow the national and regional regulations.

Do not make any modifications that impair visibility. The machine does not meet the requirements for conformity and registration.

Follow the safety instructions in the safety chapter – *see chapter "2.4 General Conduct and Safety Instructions for Operator's and Service Personal" on page 2-2.*

Requirements and information for the operating personnel

Read, understand and follow this Operator's Manual and all other Operator's Manuals supplied with the machine.

The machine may only be put into operation by authorized personnel that has been instructed – *see chapter "2.7 Staff Qualifications and Basic Responsibilities" on page 2-9.*

The operator must know and bear in mind the requirements and risks at the work place.

Perform daily maintenance according to the lubrication and maintenance plan – *see chapter "7.2 Maintenance overview" on page 7-2.*

Face the machine as you enter and exit it, and only use the mandatory climbing aids for entering and exiting.

Keep the footholds and the handholds clean to ensure a safe hold at all times. Immediately remove dirt, oil, snow, etc.

Always use the mandatory climbing aids when entering and exiting the machine.

Do not get on a moving machine, or jump off it.

Do not operate the machine if the standard protective equipment (for example the cabin) has been removed.

Watch the material as you tilt out the skip. Material stuck in the skip can cause a tipping hazard. Remove stuck or frozen material from the skip with a suitable tool.

No parts of the body or clothes may protrude outside the machine during operation.

Check lists

The checklists below assist you in checking and monitoring the machine before, during and after operation.

Wacker Neuson does not claim those lists to be exhaustive.

If the answer to one of the following questions is **No**, first rectify the cause of the error (or have it rectified) before starting or continuing work.

The checking and monitoring work listed below is described in greater detail in the following chapters.

Start-up checklist

Check and observe the following points before putting the machine into operation or starting the engine:

No.	Question	Page
1	Enough fuel in the tank?	7-20
2	Correct engine oil level?	7-26
3	Coolant level OK?	7-28
4	Hydraulic oil level correct?	7-33
5	Correct brake fluid level?	7-39
6	Glass cleaner in washer reservoir OK?	7-39
7	Lubrication points greased?	7-9
8	Tires checked for cracks, cuts, etc. ?	7-40
9	Light system, signaling, warning and indicator lights operational?	--
10	Windows, mirrors, lights, steps, all pedals and control levers clean and correctly adjusted?	--
11	All control levers and pedals in neutral position?	5-11
12	Maintenance flaps on left und right locked? Filler cap locked?	7-13
13	Especially after cleaning, maintenance or repair work: Rags, tools and other loose objects removed?	--
14	Seating position adjusted correctly?	4-4
15	Seat belt fastened?	4-6
16	Before putting the machine into operation, ensure that nobody is in the danger zone.	5-24

Operation checklist

Check/observe the following before beginning operation or after starting the engine:

No.	Question	Page
1	Are there any persons or objects in the danger zone of the machine?	5-24
2	Indicator light for engine oil pressure and alternator charge function gone out after a few seconds?	8-2
3	Has a brake test been performed?	5-5
4	Coolant temperature of engine in normal range?	8-2 8-4
5	Indicator lights for hydraulic oil filter and air filter do not illuminate?	8-2
6	Does the control lever work correctly?	5-22

Parking checklist

Check and observe the following points when parking the machine:

No.	Question	Page
1	Skip lowered?	5-15
2	Cabin locked, especially if the machine cannot be supervised?	4-2
3	Parking brake applied?	5-4

When parking on public roads:

4	Machine appropriately secured? Machine additionally secured with chocks under the wheels to prevent it from rolling away?	5-15
---	--	------

When parking on slopes:

5	Machine additionally secured with chocks under the wheels to prevent it from rolling away?	5-15
---	--	------

Putting into operation for the first time and running-in period

Before putting the machine into operation for the first time, check whether the equipment supplied with the machine is complete.

- Check the fluid levels according to chapter “**Maintenance**”.

Each machine is correctly adjusted and checked before it is delivered.

Handle the machine carefully during its first 50 operating hours.

- Do not load a cold engine.
- Warm up the machine at low engine speed and little load, do not warm it up at a standstill.
- Do not change engine speed abruptly.
- Avoid using the machine under heavy loads or at high speeds.
- Avoid abrupt acceleration, braking and changing travel direction.
- Do not run the engine at high speed for extended periods.
- Observe the maintenance plans – *see chapter “7.2 Maintenance overview” on page 7-2.*

Equipment for Austrian road traffic regulations StVZO (option)

Information

Observe the national and regional regulations during machine travel on public roads.

Scope of delivery of option **Equipment for Austrian road traffic regulations StVZO**:

- Headlights and rear lights
- Turn indicators and clearance lights
- Rotating beacon
- Horn on steering-column lever
- Outside rearview mirrors on left and right
- Numberplate bracket and lights
- Wheel chock

The rear light unit **A** can be folded in for protection during machine operation on non-public sites.

1. Remove lock pin **B** from the lock.
2. Fold the rear light unit **A** under the protection.
3. Insert lock pin **B** back into the lock.

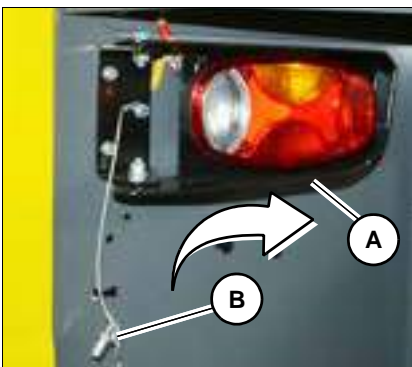
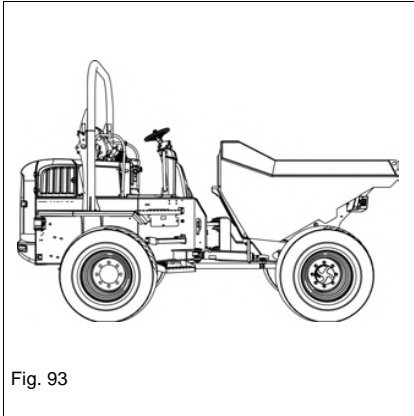

Fig. 92

Machine travel on public roads



1. Ensure that all legal requirements for machine travel on public roads are fulfilled. This applies both to the machine and to the operator (for example a corresponding driving license).
2. Lower the skip completely. If the machine is equipped with a swivel skip, ensure in addition that the skip is in the middle position.
3. Lock the control lever – see *“Enabling/disabling the operating hydraulics”* on page 5-10.

4.5 Starting and stopping the engine

Preparations for starting the engine

WARNING

Accident hazard due to unintentional operation of the machine!

Unintentional operation can cause serious injury or death.

- ▶ Only operate the machine from the seat with the seat belt fastened.

The starter cannot be actuated if the engine is already running (start repeat interlock).

Do not run the starter for more than 30 seconds.

Wait two minutes so the battery can recover and the starter does not overheat before trying again.

Information

Ensure sufficient ventilation during operation in enclosed premises.

Information

All controls must be within easy reach.

Starter

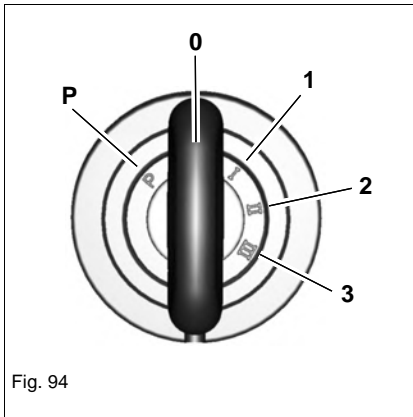

Position	Function	
P	Park position	Insert or remove the starting key
0	Stop position	
1	Position for accessories	All electric functions are enabled
2	Preheats the engine	Preheater active
3	Starts the engine	Starter is actuated

Starting the engine

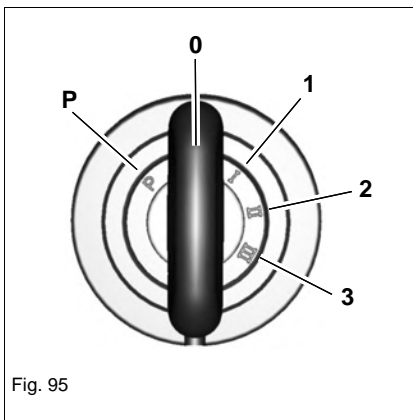

1. Switch off all electric consumers.
2. Insert the starting key.
3. Turn the starting key to position **1**.
4. All indicator lights illuminate for two seconds.
 - Have malfunctioning indicator lights immediately replaced.
5. Turn and hold the starting key in position **2** until indicator light **A** (preheating) goes out.
 - Indicator light **B** (alternator charge) illuminates.
 - Indicator light **C** (engine oil pressure) illuminates.
6. Turn and hold the starting key in position **3** until the engine starts.
 - Release the starting key.
 - All indicator lights go out.

If the engine does not start after 30 seconds:

Interrupt the start procedure and repeat it after two minutes.

If the engine still does not start after a few tries, contact a Wacker Neuson service center.

Warm-up phase

After starting the engine, let it warm up at slightly increased idling speed until it reaches its operating temperature.

Check for unusual noise, exhaust color, leaks, malfunctions or damage.

In case of malfunctions, damage or leaks:

Secure the machine, park it and find out the cause for the damage and have it repaired.

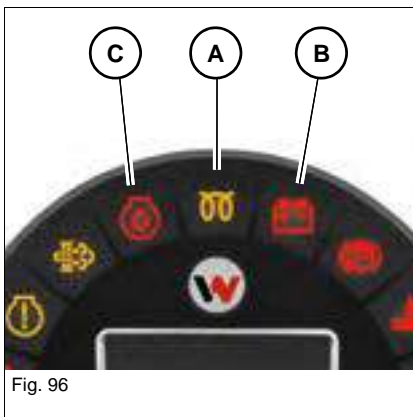

Starting the engine at low ambient temperatures

Start the engine as described in chapter **Starting the engine**.

Warm-up phase at low ambient temperatures

- Let the engine run below 1800 rpm until the coolant reaches its operating temperature.
- Avoid fast movements of the operating hydraulics.
- Check for unusual noise, exhaust color, leaks, malfunctions or damage.

In case of malfunctions, damage or leaks:

Secure the machine, park it and find out the cause for the damage and have it repaired.

Notices on the warm-up phase

- After reaching the operating temperature, the engine can be operated under full load.
- The engine reaches its operating temperature more quickly at low engine speed and under load. This is more efficient than operation at low engine speed without any load.
- Avoid excess idling. This causes carbon deposits or an increased soot load of the particulate matter catalyst, for example.



WARNING

Crushing hazard during operation with cold hydraulic oil!

Cold hydraulic oil can cause uncontrolled machine movements. This can cause serious injury or death.

- ▶ The hydraulic oil is still cold even if the engine has reached its operating temperature.
 - ▶ If possible, run the machine warm on wide and open terrain.
 - ▶ Operate the control lever especially carefully if the hydraulic oil is cold.
-

Starting aid

 **WARNING****Explosion hazard in case of incorrect handling of battery!**

Incorrect battery handling can cause serious injury or death.

- ▶ Wear protective equipment.
 - ▶ Fire, open flames and smoking is prohibited.
 - ▶ Do not jump start the engine if the battery is malfunctioning or frozen, or if the acid level is too low.
-

 **WARNING****Burn hazard due to hot surfaces!**

Can cause serious burns or death.

- ▶ Stop the engine and let it cool down.
 - ▶ Wear protective equipment.
-

 **WARNING****Injury hazard due to rotating parts!**

Rotating parts can cause serious injury or death.

- ▶ Open the maintenance flap only at engine standstill.
-

NOTICE

Damage to machine due to electrical short-circuit or overvoltage.

- ▶ Do not bring the positive terminal of the starting battery into contact with electrically conductive vehicle parts.
 - ▶ The vehicles must not touch each other during the starting aid.
 - ▶ If the engine still does not start despite a starting aid, contact a Wacker Neuson service center.
-

NOTICE

Possible damage due to wrong battery voltage.

- ▶ Only use batteries with the same voltage (12 V).
-

NOTICE

Possible damage to machine with empty battery due to voltage peaks.

NOTICE

Damage to battery jumper cables when placing them near rotating parts.



Information

Use only authorized battery jumper cables which conform to national and regional safety requirements.

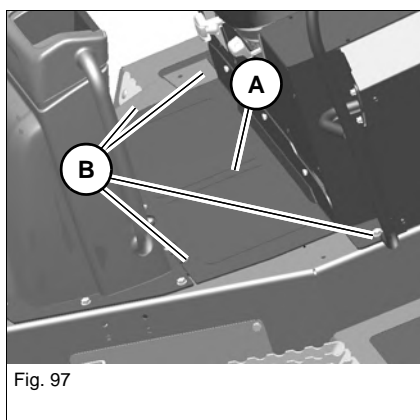
Designations/symbols	Meaning
X	Machine with empty battery
Y	Vehicle with full battery
C	Positive/machine X
D	Positive/vehicle Y
E	Negative/vehicle Y
F	Negative/machine X
	Full battery

**Connections**

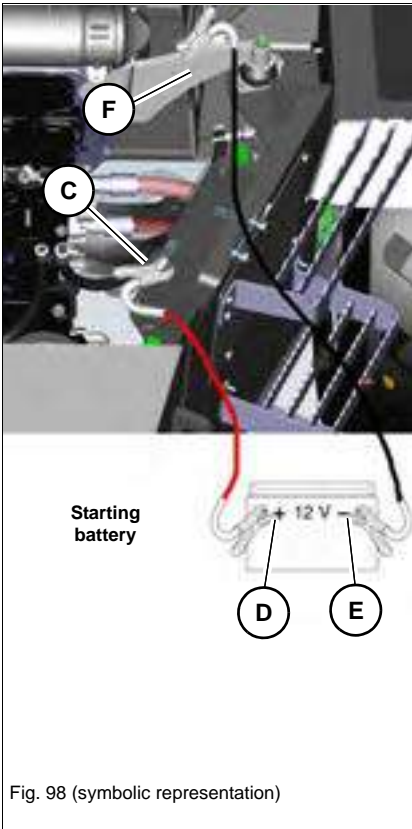
1. Move vehicle **Y** close to machine **X** so that the length of the battery jumper cables is sufficient.
2. Let the engine of vehicle **Y** run.
3. Remove rubber mat **A**.
4. Remove screws **B**.
5. Remove the base cover.



6. Open the engine cover.
7. Connect the battery jumper cables in the following order: **C-D-E-F**.
8. Wait five minutes for the empty battery to be charged a little.

 **WARNING**

Injury hazard due to open base cover!

Can cause serious injury and death.

- ▶ Ensure a secure footing when you get on the machine with the base cover open.

9. Start the engine of machine **X**.
10. Disconnect the battery jumper cables in the following order: **F-E-D-C**.
11. Install the base cover again and secure it with the screws.
12. Fit rubber mat **A**.

Low-load operation

NOTICE

Possible damage to the engine due to low-load operation.

- ▶ Run the engine at idling speed or at high engine speed at over 20 % engine load.

Possible consequences of low-load operation are:

- Increased engine oil consumption
- Engine contamination due to engine oil in exhaust system
- Blue smoke in exhaust gas
- Shorter particulate matter catalyst regeneration cycles (only in case of Tier IV)
- Reduced engine-oil replacement intervals

Stopping the engine

NOTICE

Possible damage to the engine when it is stopped after running under high load.

- ▶ Letting the engine run at idling speed before stopping it avoids engine damage and increases the engine's service life.

-
1. Let the engine run at idling speed for five minutes without any load.
 2. Turn the starting key to "0" and remove it.

Information

After stopping the engine, wait two minutes before disconnecting the battery or actuating the battery master switch to avoid damage to the control electronics.

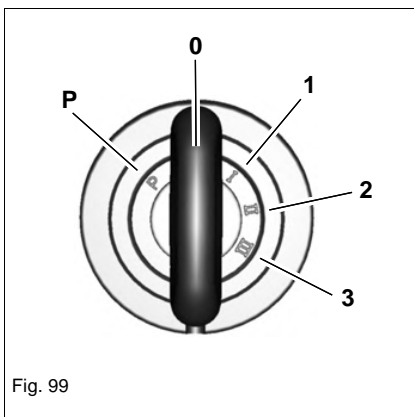

Fig. 99

5 Operation

Instrument panel cover

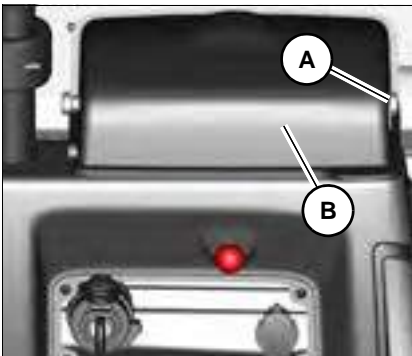

Fig. 100

Before putting the machine into operation, open lock **A** with the starting key and slide back instrument panel cover **B** until it locks into place.

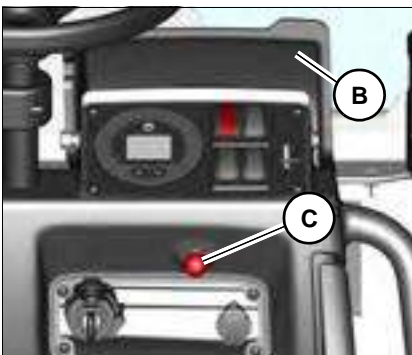

Fig. 101

Leave instrument panel cover **B** open during operation.

To lock instrument panel cover **B**, disengage it from the lock, close it and lock it with ball handle **C**.

Tarp (option)

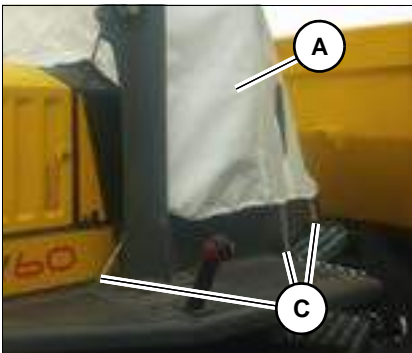

Fig. 102

In the case of machines without cabin, the control stand can be protected with a tarp.

Fasten tarp **A** with hooks **B** on the machine.

5.1 Steering system

The machine is steered with a steering wheel. The mechanical actuation is transmitted to a travel cylinder. Steering is therefore not performed by means of a steering axle, but with the steering joint.

Function	Machine movement
Steering wheel turned to the left	Machine is steered to the left and turns left
Steering wheel turned to the right	Machine is steered to the right and turns right

Emergency steering features

The machine can still be steered if the engine or the pump unit breaks down, however this requires more muscle strength. Take this into account especially when towing the machine.

5.2 Accelerator actuation

Accelerator pedal

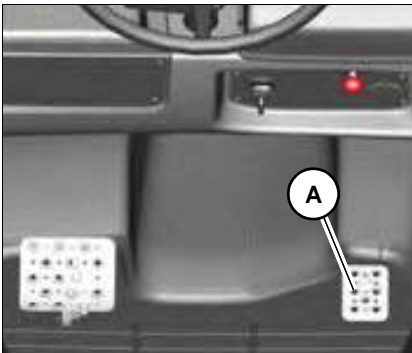

Fig. 103

Accelerator pedal **A** is located on the right in the leg room. Speed is set continuously with accelerator pedal **A**.

Speed changeover

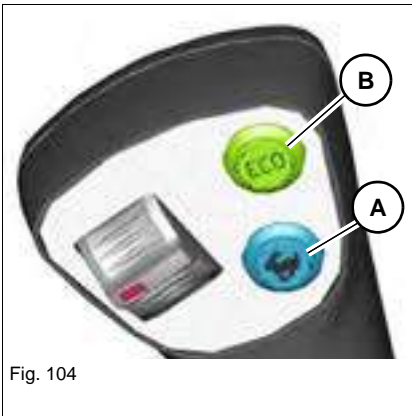

Fig. 104

Models DW90 and DW100 have two speed ranges that can be selected with push button **A** on the control lever. The Eco mode is selected with push button **B**. Fuel-saving operation is selected with this mode, and maximum speed is reduced – see *“Maximum speed” on page 9-5*.

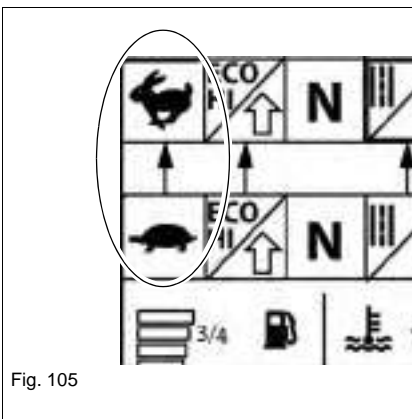

Fig. 105

Indication of speed ranges in multifunctional display

Function	Machine movement
Speed range 1	Turtle
Speed range 2	Hare

Keep the service brake pressed to change over. The machine must be at a standstill.

5.3 Brakes

Service brake

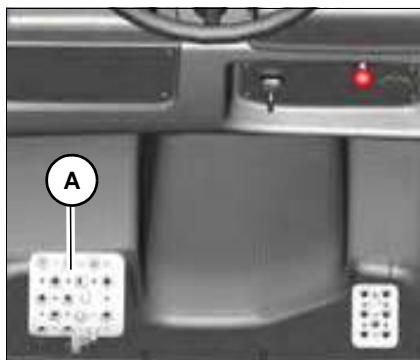

Fig. 106

The service brake is located on the left in the leg room. Reduce the travel speed progressively with service brake **A**.

If the accelerator pedal is not pressed, the travel speed is reduced until the machine comes to a standstill, but very slowly.



Information

Reduce the travel speed with service brake **A**.

Parking brake

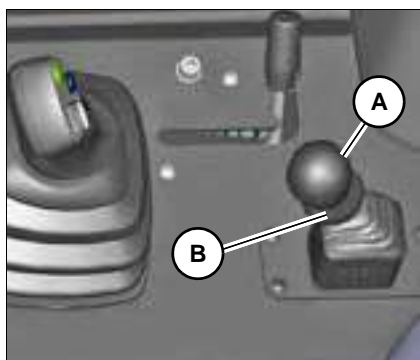

Fig. 107

Parking brake lever **A** is located on the right.



WARNING

Accident hazard! Do not operate the unlocking device during machine travel!

Can cause serious injury or death.

► Use the parking brake only at machine standstill.

Function	Position
Applies the parking brake	Pull unlocking device B upward and press parking brake lever A backward
Release the parking brake	Pull unlocking device B upward and press parking brake lever A forward

The parking brake may be used briefly in case of a service brake malfunction. Pull the parking brake backward only to the notch for this. Do not operate the lock lever under any circumstances. Contact a Wacker Neuson service center.



Information

The parking brake responds with a certain delay, but then with a strong braking effect.

Brake test

Information

Do not put the machine into operation if a brake test gives a negative result or if there are doubts as to the correct brake function. Contact a Wacker Neuson service center and have the malfunction rectified.

The following tests help check the brake function. If possible, always park the machine without any load and on level ground, and secure it with suitable means (for example chocks).

Perform the brake tests once a day on firm, level and horizontal ground. First perform the test for the parking brake, then the one for the service brake.

Parking brake test

Information

The parking brake test may not last longer than 30 seconds. The machine automatically disables the traveling drive after 30 seconds if the parking brake is applied.

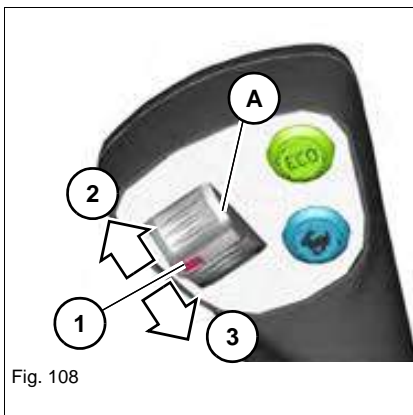

Fig. 108

1. Lower the skip.
2. Apply the parking brake.
3. Start the machine.
4. Set the forward-reverse control **A** to position **1**.
5. Set the engine speed to a minimum 1300 revolutions with the accelerator pedal and hold it for 5 seconds.
 - The machine must not move, or only very slowly.
 - The pressure increase in the machine-travel hydraulics must be clearly audible.
 - The travel direction must be displayed on the multifunctional display.

Service brake test

1. Start the machine.
2. Lower the skip.
3. Press the service brake with a foot strength of more than 40 kg and hold it with this strength.
4. Select the 1st speed range
5. Press and hold the accelerator pedal at least 5 seconds.
 - The brake pedal must not give way.
 - The machine must not move.

Multifunctional display

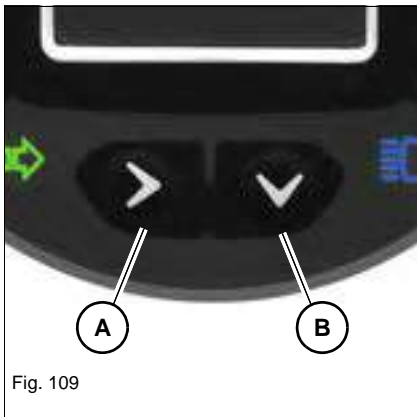
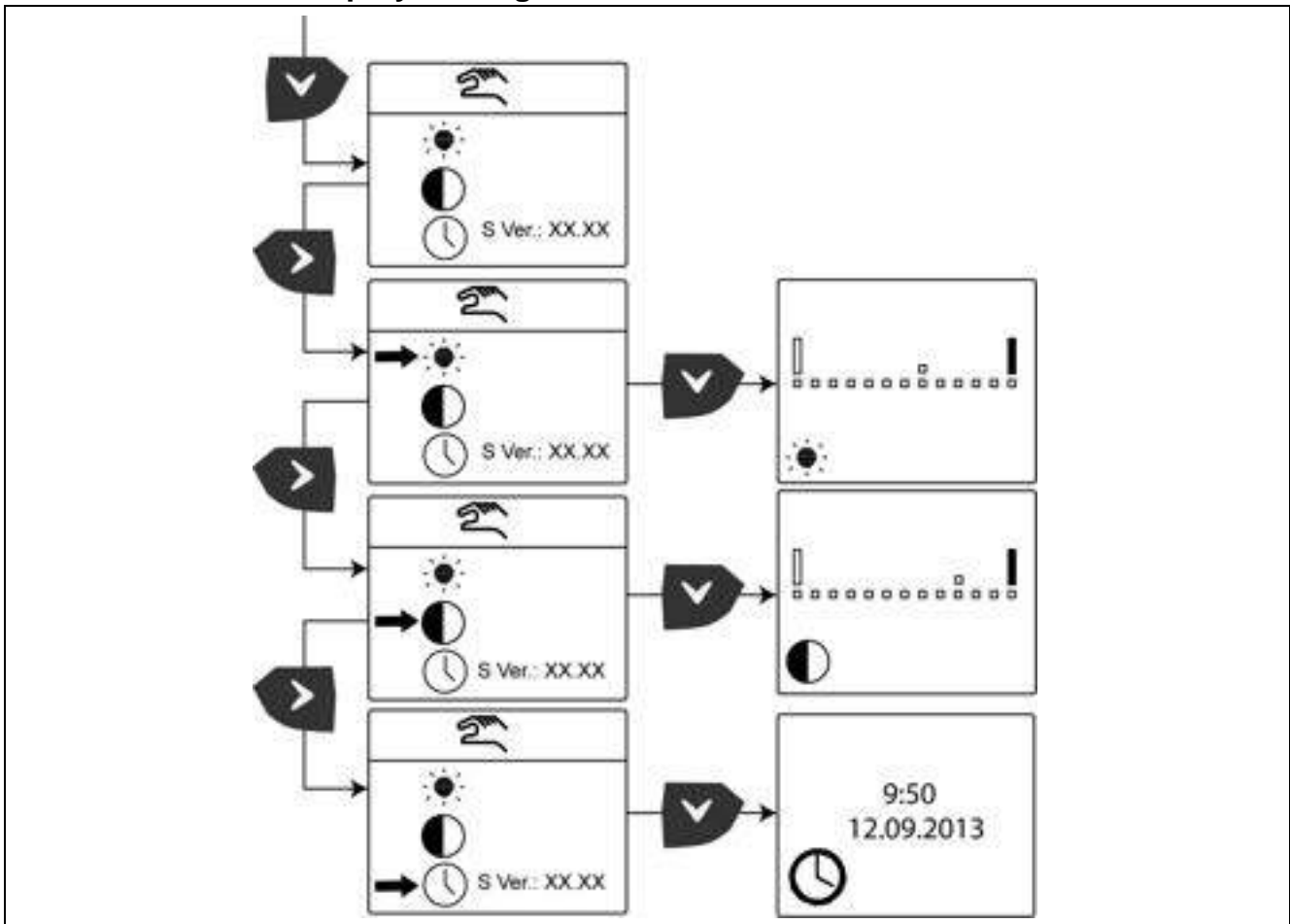

Fig. 109

Display element buttons

- A: selection button
- B: to next menu page/set

Menu structure of display setting



i Information

The software version number is displayed from version 3.3.

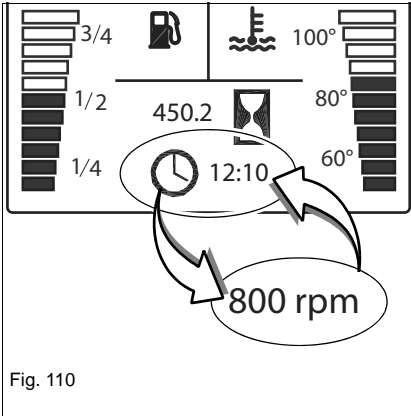

Fig. 110

Time/engine speed changeover

Change over between engine speed and time with push button **A**.

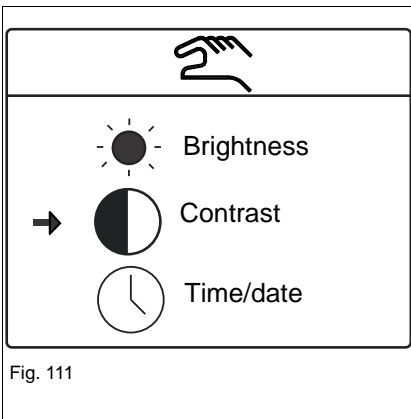

Fig. 111

Display adjustment menu

The selected menu level is marked with an arrow.

Press push button **A** 1 x: brightness

Press push button **A** 2 x: contrast

Press push button **A** 3 x: time/date

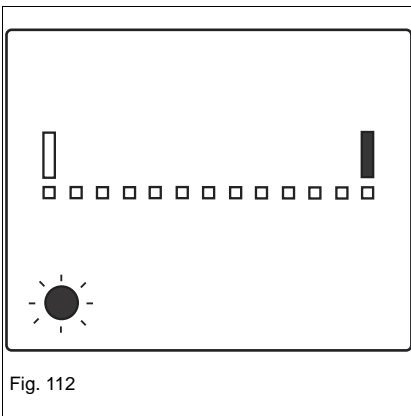
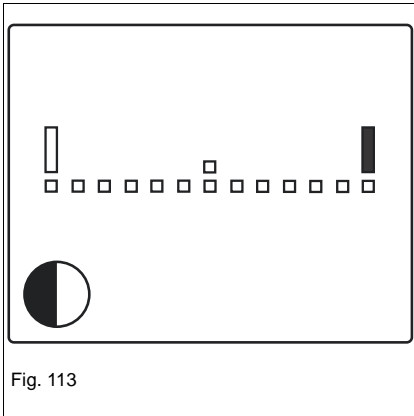

Fig. 112

Adjusting brightness

Press push button **B** to access the adjustment mode.

Press push button **A** to adjust brightness.



Adjusting contrast

Press push button **B** to access the adjustment mode.

Press push button **A** to adjust the contrast.

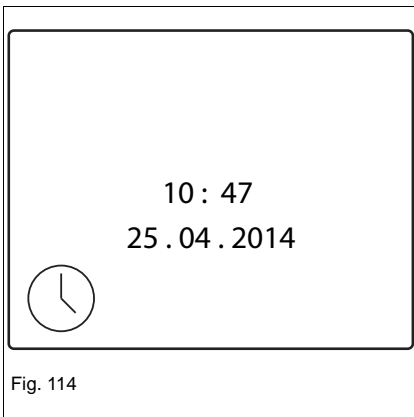

Setting the time or date

Adjustment sequence: year/month/day/hours/minutes

Press push button **B** to access the adjustment mode.

Press push button **A** to set or to access the next setting (month, day, etc.).

Press push button **A** until the display adjustment menu appears again.

Otherwise the selected modifications are not saved.

5.4 Machine travel

 **WARNING**

Accident hazard due to incorrect adjustment of travel direction!

Can cause serious injury and death.

- ▶ Ensure that the surrounding area is clear.
 - ▶ Set the forward-reverse control to the required position before starting machine travel.
-

 **WARNING**

Accident hazard due to machine rolling away under its own weight!

Can cause serious injury and death.

- ▶ Change over the travel direction only if the machine is at a standstill and if the service brake is actuated.
-

 **WARNING**

Accident hazard due to travel direction changeover during machine travel!

Can cause serious injury and death.

- ▶ Change over the travel direction only if the machine is at a standstill and if the service brake is actuated.
-

Road-travel position

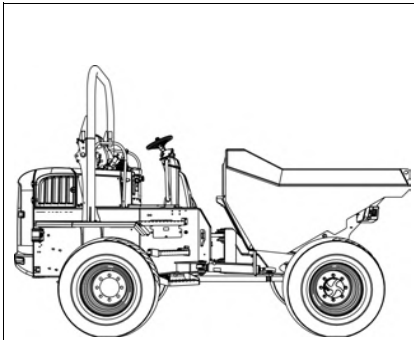

Fig. 115

Lower the skip and secure it against unintentional operation with lock lever **A**.

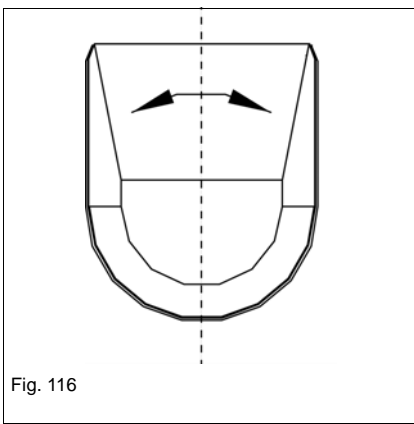

Fig. 116

If the machine is equipped with a swivel skip, ensure that it is in the middle position.

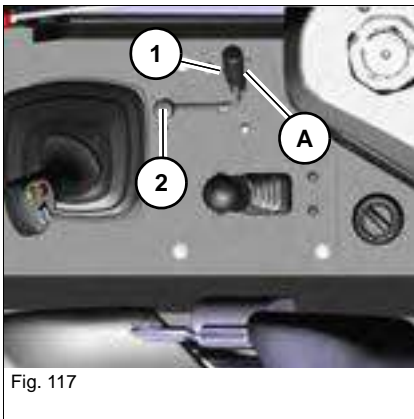
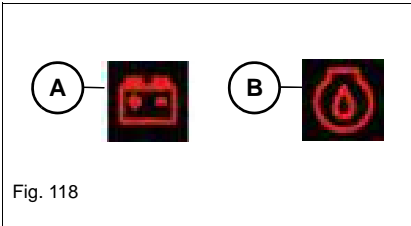

Fig. 117

Enabling/disabling the operating hydraulics

Function	Position
Disables the operating hydraulics (road-travel position)	Put lock lever A in position 1
Enables the operating hydraulics (work position)	Put lock lever A in position 2

Starting machine travel and stopping



Starting machine travel

- Start the engine.
 - ➔ Indicator lights **A** (charge indicator light) and **B** (engine oil pressure) go out.
- Press the service brake.

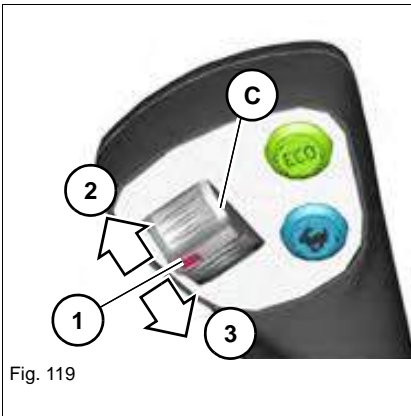

Selecting a travel direction

After starting the engine, position 1 has to be selected otherwise the machine cannot be moved forward for safety reasons.

- Set forward-reverse control **C** to the required position before starting machine travel:
 - 1: Neutral position
 - 2: Forward
 - 3: Reverse
- Release the parking brake.
- Press the accelerator pedal.
 - ➔ Machine travel starts.

Stopping

During machine travel:

- Do not actuate the accelerator pedal any more.
 - ➔ If the accelerator pedal is not pressed, the travel speed is reduced until the machine comes to a standstill, but very slowly.
- Press the service brake.
 - ➔ The machine stops.

Operating temperature range

Operate the machine only at ambient temperatures between -15 °C (5 °F) and $+45\text{ °C}$ ($+113\text{ °F}$).

Machine travel on slopes

WARNING

Crushing hazard due to tipping over of machine!

A tipping machine can cause serious injury or death.

- ▶ Set the machine to travel position.
 - ▶ Perform machine travel on slopes only on firm ground.
 - ▶ Adapt the travel speed to the prevailing conditions.
 - ▶ Avoid sudden travel movements.
 - ▶ Pay attention to persons and obstacles.
 - ▶ Pay attention to the stability limits of the machine (maximum gradient angle 25 %, maximum lateral angle of inclination 25 %).
 - ▶ Perform uphill and downhill machine travel only in speed range 1.
 - ▶ Ensure that no parts of the body protrude outside the machine.
 - ▶ Do not exceed the permissible payloads.
 - ▶ Do not turn or tilt out a full skip during uphill or downhill machine travel.
 - ▶ Tilt out the skip on slopes only on the uphill side of the machine.
 - ▶ Diagonal machine travel is prohibited.
-

Stones and the humidity in the upper layer of the ground can affect machine traction and stability.

The machine can slip sideways on gravel or loose, rocky soil. The stability of the machine can be reduced on rough terrain.

On soft ground, the machine sinks into it or the wheels dig into it. This increases the machine angle (maximum gradient angle and maximum lateral angle of inclination), and the machine can tip over.

If the engine dies during uphill or downhill machine travel, immediately put the forward-reverse control in neutral position and start the engine again.

The machine can slip even on gentle slopes if it travels across for example grass, leaves, humid metal surfaces, frozen ground or ice.

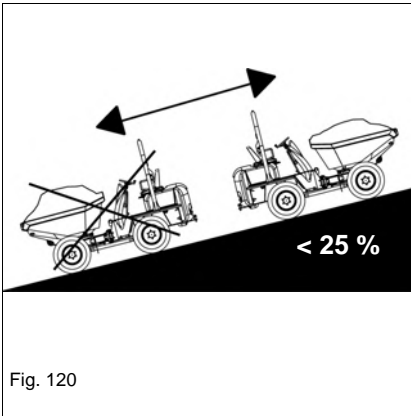
**Machine travel on slopes with a loaded skip**

When performing machine travel on slopes with a loaded skip, the front side of the machine must always face the uphill side of the slope whichever the travel direction. Do not perform machine travel on slopes steeper than 25 %.

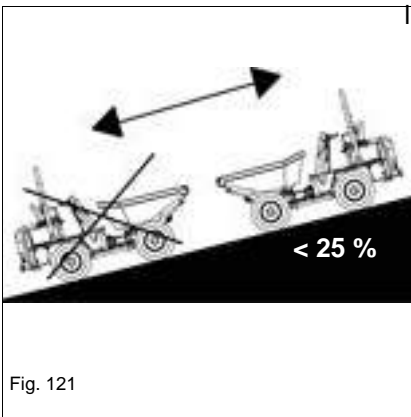
**Machine travel on slopes with an unloaded skip**

When performing machine travel on slopes with an unloaded skip, the front side of the machine must always face the downhill side of the slope whichever the travel direction. Do not perform machine travel on slopes steeper than 25 %.

**Information**

The engine brake does not have enough effect at a certain engine speed during downhill travel. Reduce engine speed.

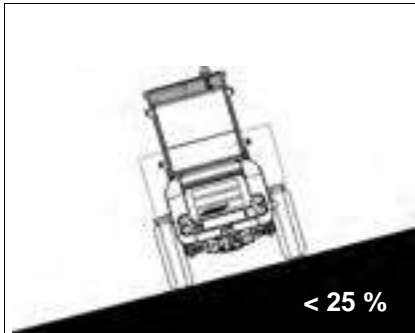

Fig. 122

Machine travel across slopes

Do not perform machine travel on slopes with a lateral angle of inclination over 25 %.

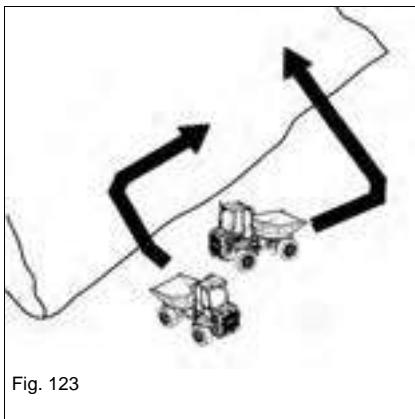

Fig. 123

Change position on level ground and then perform straight-ahead machine travel onto the slope.

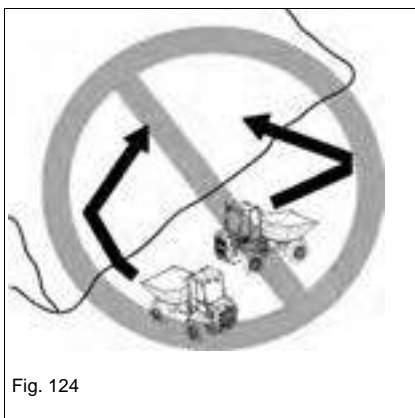

Fig. 124

Diagonal machine travel is prohibited.

Parking the machine

WARNING

Crushing hazard due to machine rolling away under its own weight after parking it!

Serious injury or death can be caused by not securing the machine.

- ▶ Lower the skip. At near-freezing temperatures, park the machine with the skip tilted to prevent material from freezing or ice from forming in the skip. Secure the skip with the maintenance prop.
- ▶ Secure the machine accordingly (for example with chocks).

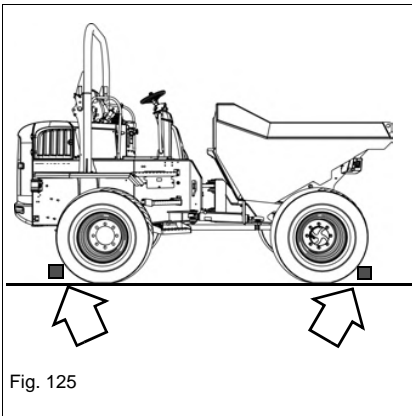

1. Park the machine on firm, level and horizontal ground. The machine may be parked on a slope only if it cannot be avoided. Park the machine only transversely to the slope as you do so.
2. Lower the skip.
3. Stop the engine.
4. Apply the parking brake.
5. Remove the starting key and carry it with you.
6. Close and lock all covers and the door (option).
7. Secure the wheels accordingly (for example with chocks, blocks).

Information

In order to prevent the formation of condensation water, fully fill up the fuel tank at the end of each working day.

5.5 Differential lock

Not available.

5.6 Lights/signaling system

Working lights (option)

The switch is located on the right of the steering wheel.

WARNING

Motorists can be blinded by bright lights on the job site!

Working lights can blind motorists. This can cause serious injury or death.

- ▶ Stop machine operation if motorists are blinded.
- ▶ Only take up work again if sufficient illumination of the job site can be ensured without blinding other motorists.

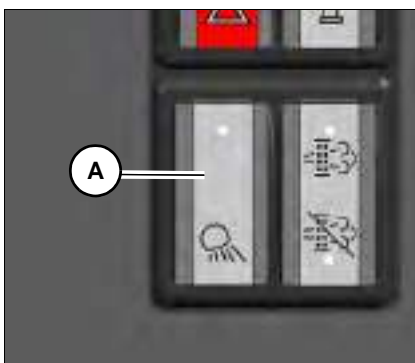

Fig. 126

Function	Position
Switch off the working lights	Press switch A all the way up
Switch on the front working lights B	Press switch A to the first position
Switch on the front B and rear C working lights	Press switch A to the second position

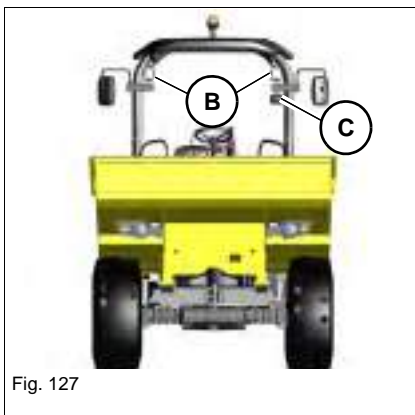

Fig. 127

Information

Turn on the working lights in conditions of poor visibility. If illumination still is not sufficient, use external lights. If this still does not illuminate the job site sufficiently, stop machine operation and take it up again only when sufficient illumination is ensured.

Road travel lights (option)

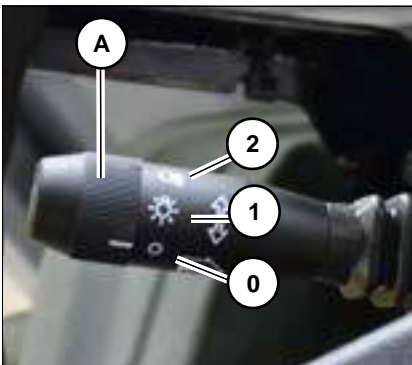

Fig. 128

The steering-column lever is located on left of the steering wheel. Ring **A** is located on the steering column lever.

Function	Position
Switch off the lights	Turn ring A to position 0
Switch on clearance lights (B) and rear lights (C)	Turn ring A to position 1
Switch on headlights (D)	Turn ring A to position 2

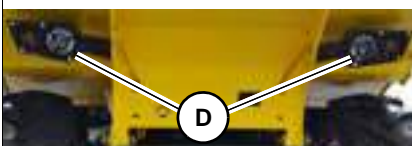
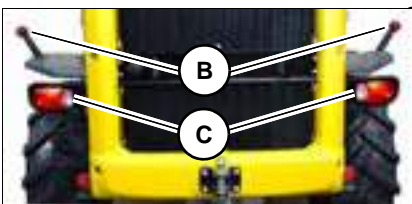

Fig. 129

Clearance lights **B**, rear lights **C** and headlights **D**.

Interior light (option)

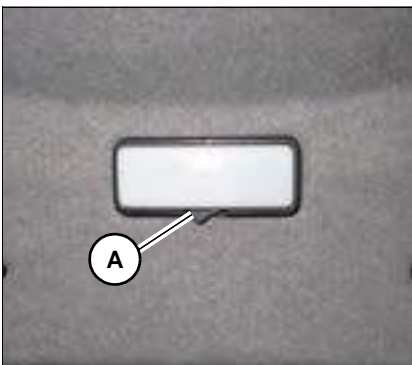
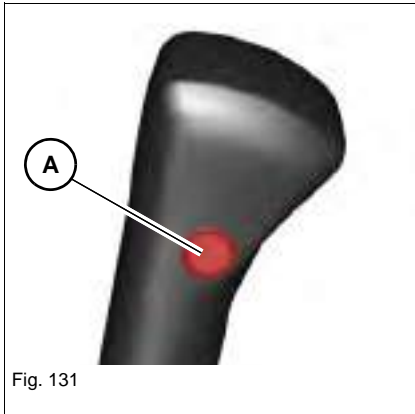

Fig. 130

Switch **A** is located on the interior light.

Function	Position
Switch off the interior light	Press switch A to the middle position or to the right
Switch on the interior light	Press switch A to the left

Horn



Press push button **A** on the rear side of the control lever.

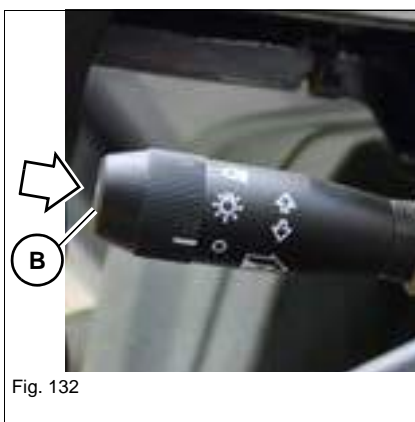

Press push button **B** on the steering column lever (option for Austrian road traffic regulations StVZO).

Rotating beacon (option)

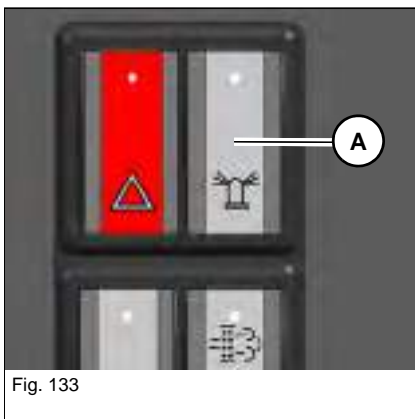

Switch **A** is located on the right of the steering wheel.

Function	Position
Switch off rotating beacon B	Press switch A upward
Switch on rotating beacon B	Press switch A down

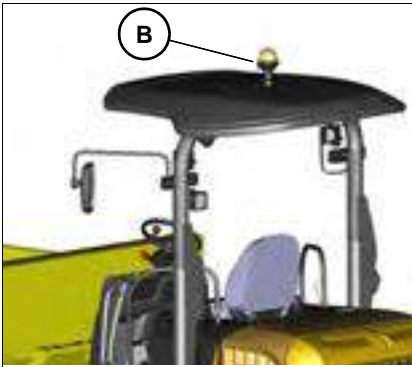

Fig. 134

i **Information**

Follow the national and regional regulations concerning rotating beacon operation.

Turn indicators (option)

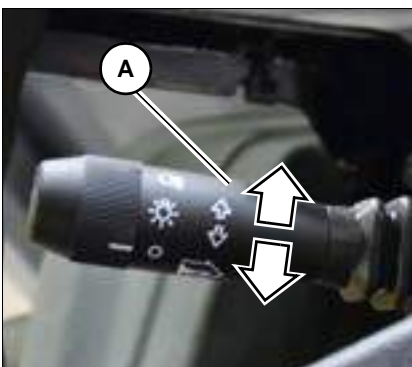

Fig. 135

The steering-column lever is located on left of the steering wheel. Operating the turn indicators on the steering column lever.

Function	Position
Turn indicators on the left flash	Press steering column lever A down
Turn indicators on the right flash	Press steering column lever A up

Hazard warning system (option)

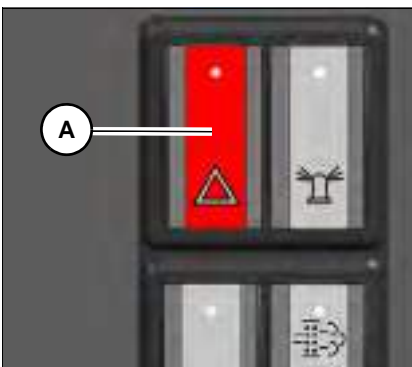

Fig. 136

The switch is located on the right of the steering wheel.

Function	Position
Switch off the hazard warning system (B)	Press switch A upward
Switch on the hazard warning system (B)	Press switch A down

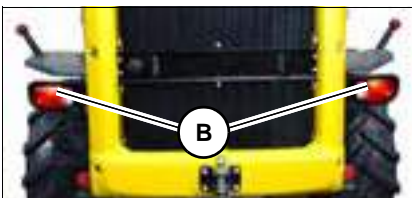

Fig. 137

Reversing signal (option)

The reversing signal sounds during backward machine travel.

DANGER

Accident hazard during forward/backward machine operation!

Serious crushing hazard causing death or serious injury.

- ▶ Do not allow anyone to stay in the danger zone.
- ▶ Do not rely on the reversing signal under any circumstances.
- ▶ If the reversing signal does not sound, stop machine operation immediately and contact a Wacker Neuson service center. Follow the national and regional regulations.

5.7 Wiper/wash system (option)

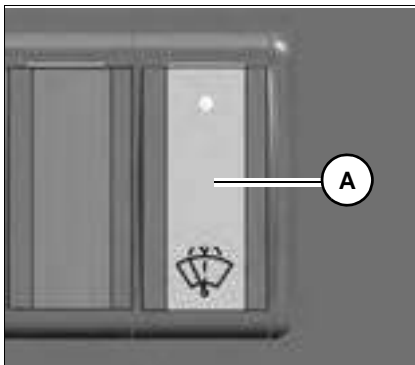

Fig. 138

The switch is located on the rear left beside the operator seat.

Function	Position
Switch off the wiper	Press switch A backward
Wiper function	Press switch A to the first position
Wiper and spraying function	Press and hold switch A in the second position

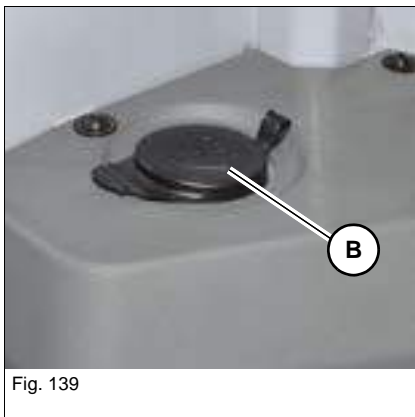

Fig. 139

Reservoir **B** for the cleaning solution of the washer system is located on the right in the cabin.

NOTICE

Damage to pump if the reservoir is empty.

- ▶ Do not actuate the washer system if the reservoir is empty.
- ▶ Check the level in the reservoir and add a cleaning solution (glass cleaner) if necessary.

5.8 Heating, ventilation and air conditioning system

Heating/ventilation (option)

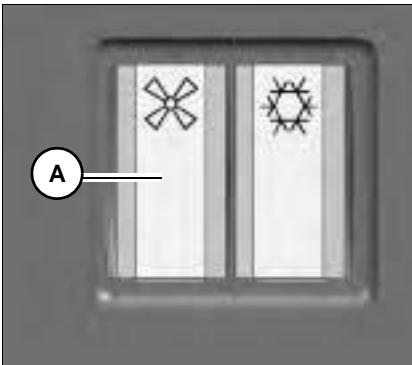

Fig. 140

Switch **A** is located on the left beside the operator seat.

Function	Position
Switch off the fan	Press switch A all the way up
Fan in 1st speed	Press switch A to the first position
Fan in 2nd speed	Press switch A to the second position

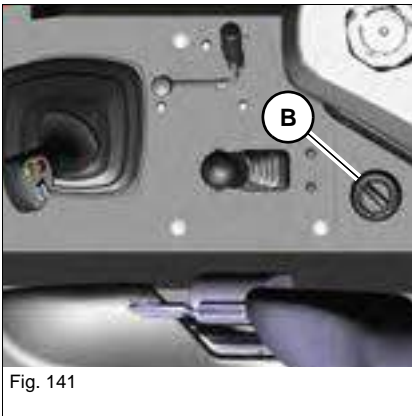

Fig. 141

Temperature setting

Regulator **B** is located on the right beside the operator seat.

Function	Position
Heating	Turn regulator B anticlockwise
Ventilation	Turn regulator B clockwise

Air conditioning (option)

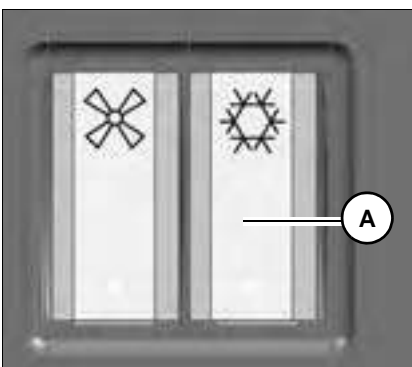

Fig. 142

Switch **A** is located on the left beside the operator seat

Function	Position
Switch off the air conditioning	Press switch A to the front
Switch on the air conditioning	Press switch A backward

Information

Switch on the air conditioning system once a month for at least 10 – 15 minutes to ensure its full function and efficiency.

5.9 Operating hydraulics

Skip operation

Operate the skip with the control lever.

 **WARNING**

Accident hazard during machine travel with a tilted-out skip!

Can cause serious injury or death.

- ▶ Machine travel with a tilted-out skip is prohibited.
 - ▶ Tilt out material that sticks in the skip only to the front in the straight position of the machine.
 - ▶ Keep a safe distance (for example from buildings, edges of building pits) as you tilt out the skip.
 - ▶ Perform machine travel only on firm ground.
-

 **WARNING**

Crushing hazard due to machine tipping over!

Tilting out the skip very quickly can cause the machine to tip over. Serious injury or death can be caused by a tipped-over machine.

- ▶ Lower the skip slowly.
-

NOTICE

Lowering the skip very quickly onto the chassis can cause damage to the machine.

Front skip operation



Fig. 143

During skip operation, always put forward-reverse control **B** for the travel direction in neutral position **1**.

Function	Operation
Tilt out the skip	Press control lever A forward
Lower the skip	Pull control lever A backward

Swivel skip operation

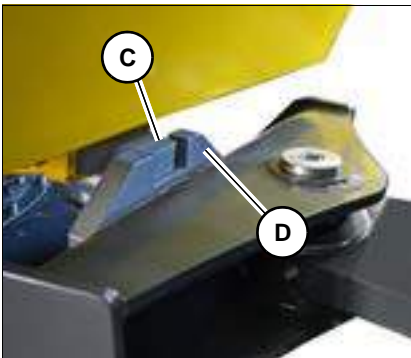

Fig. 144

In order to turn the skip, raise it with control lever **A** until lock **C** is raised from guide **D**.

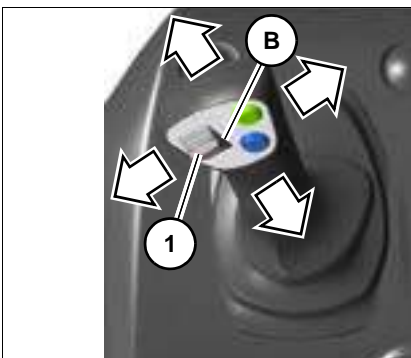

Fig. 145

During skip operation, always put slide switch **B** for the travel direction in neutral position **1**. Lower the skip only in the straight position to avoid damage to the lock.

Function	Operation
Tilt out the skip	Press control lever A forward
Lower the skip	Pull control lever A backward
Skip is turned to the left	Push control lever A to the left
Skip is turned to the right	Push control lever A to the right

5.10 Attachments

Not available.

5.11 Work operation

Danger zone

- The danger zone is the area in which persons are in danger due to the movements of the machine or load.
- The danger zone also includes the area that is affected by falling material, equipment or by debris that is thrown out.
- The danger zone on a slope is different from the one on a level surface (secure the load). Stop machine operation immediately as soon as someone enters the danger zone – *see chapter “Machine travel on slopes” on page 5-12.*
- Seal off the danger zone should it not be possible to keep a sufficient safety distance.
- Extend the danger zone sufficiently in the immediate vicinity of buildings, scaffolds or other elements of construction.

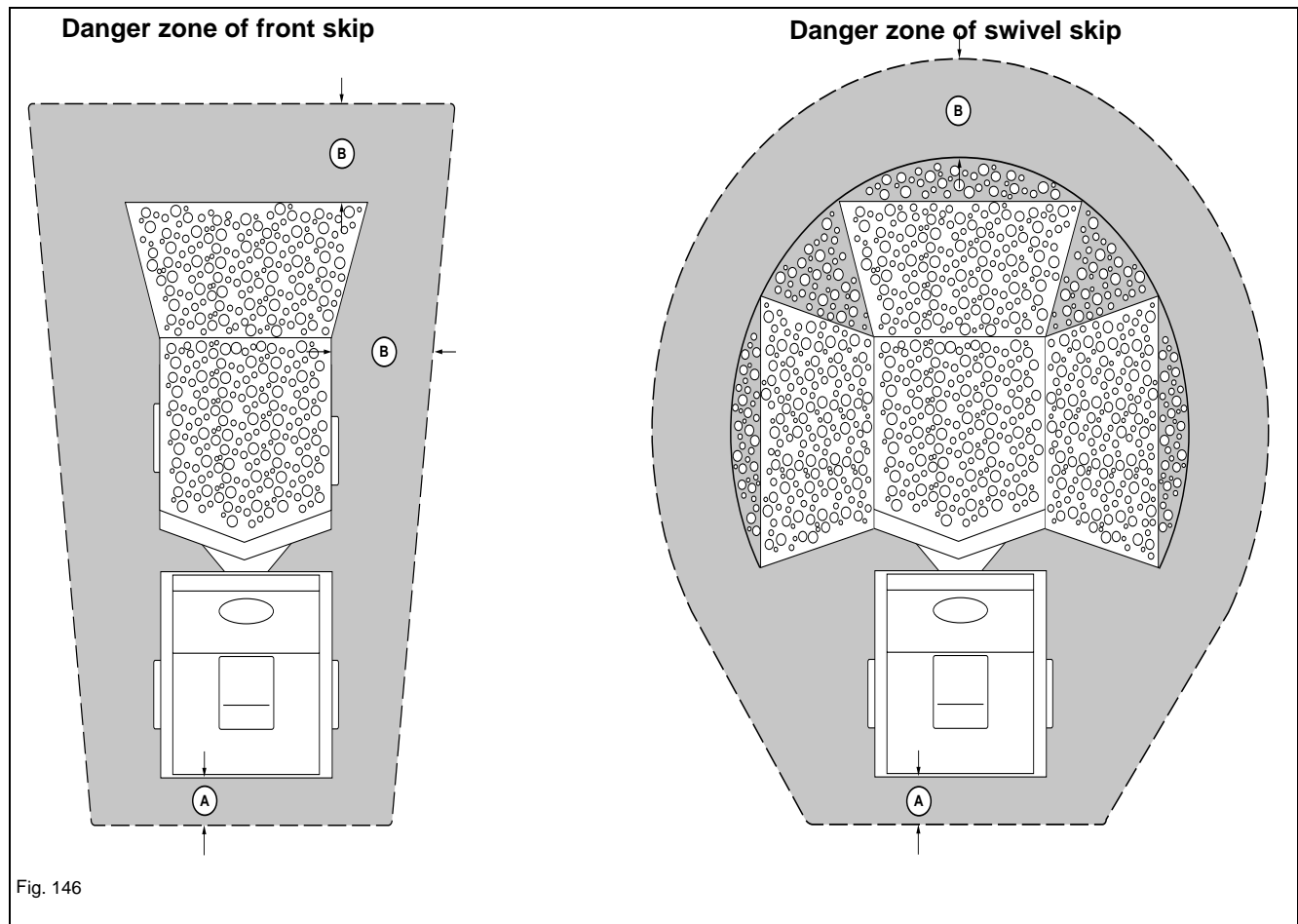

Fig. 146

Symbol	Description
----	Danger zone
(A)	Safety distance of 1.5 m (59 in)
(B)	Safety distance of 2.5 m (98 in)

- Do not travel up to the edge of an unsecured pit – danger of cave-in.
- Do not perform machine travel and operation under projecting earth. Stones or the projecting earth can fall onto the machine.
- Before working on roofs or similar structures, check the resistance and the structure itself before starting work. The building can collapse, causing serious injury and damage.
- The hydraulic system of the machine is still pressurized even when the engine is not running. Release the pressure in the hydraulic system before starting repair work.
- Before tilting out the skip next to an excavation, secure the machine with suitable wheel chocks or other auxiliary means.
- Watch the material as you tilt out the skip. Material stuck in the skip can cause a tipping hazard. Remove stuck or frozen material from the skip with a suitable tool.
- Do not unload the load on sloping ground.
- Do not transport any persons or animals in the skip.
- Performing machine travel with a tilted-out skip is prohibited.

Loading



WARNING

Injury hazard when loading the machine

Can cause serious injury or death.

Leave the machine before loading it, and get onto it again only after it is completely loaded.



Information

Incorrect loading causes serious damage to the machine.

- ▶ Do not exceed the payload.
 - ▶ Ensure that the operator's visibility is not impaired.
-

Before loading

1. Lower the skip.
2. Move the control lever to neutral.
3. Apply the parking brake.
4. Stop the engine.
5. Leave the machine and the danger zone.

Once loading is over

1. Remove dirt, debris, dust, etc. from the control elements.
2. Remove loose material.

Transporting with a full skip



WARNING

Accident hazard when transporting with a full skip!

Can cause serious injury or death.

- ▶ Put a full skip to transport position before performing machine travel.
 - ▶ Observe the national and regional regulations when transporting with a full skip.
-

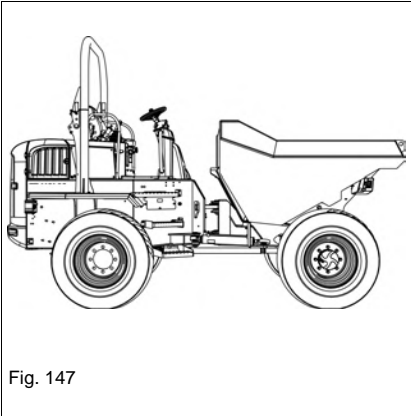
**Transport position**

Lower the skip completely. If the machine is equipped with a swivel skip, ensure in addition that the skip is in the middle position.

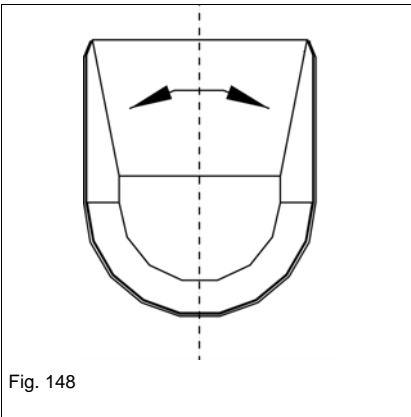

Middle position of swivel skip.

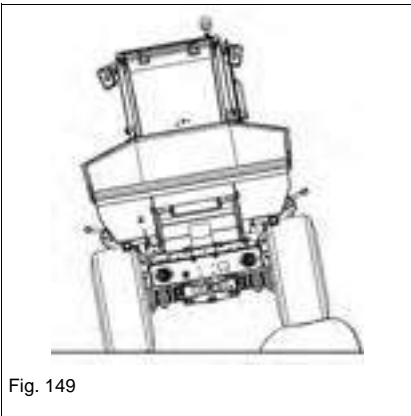
General information regarding work operation**Speed range 1**

Perform machine travel slowly on rough terrain and avoid starting machine travel and stopping abruptly as well as changing direction suddenly. Avoid machine travel over obstacles if possible, otherwise go over them at low speed.

Speed range 2

The DW90 and DW100 machines are equipped with an additional 2nd speed range. This speed range makes it possible to perform machine travel at higher speeds depending on the ground and the surroundings.

**Information**

Follow the applicable national and regional regulations.

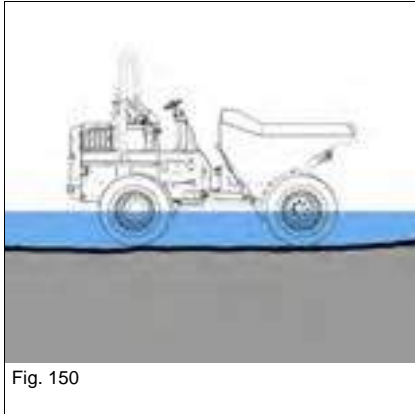

Operation in water

Do not immerse the machine in water any farther than to the middle of the axles.

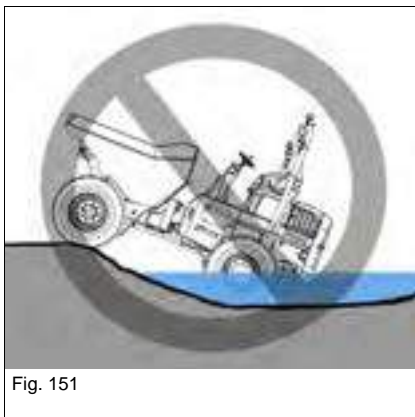

Information

Operation in salt water is prohibited.

When leaving the water, take special care not to immerse the rear end of the machine in the water, in particular the exhaust system.

After using the machine in water, have the axles checked by a Wacker Neuson service center.

5.12 Emergency lowering

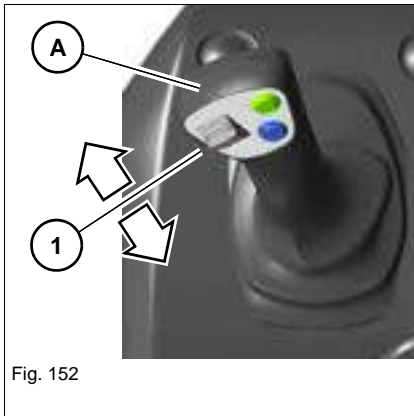

DANGER

Crushing hazard when lowering the skip!

Causes serious crushing or injury resulting in death.

- ▶ Do not allow anyone to stay in the danger zone.
- ▶ Stop all work movements immediately if someone enters the danger zone.

Information

Lower the skip immediately after stopping the engine.

Lower the skip in case of an engine or hydraulic system malfunction.

The skip can also be lowered if the starter is disengaged. To do this: pull control lever **A** backward.

5.13 Options

Operator presence switch

Performing a functional check of the operator presence switch.

– see chapter “*Functional check of operator presence switch (option)*” on page 4-4

Immobilizer (option)

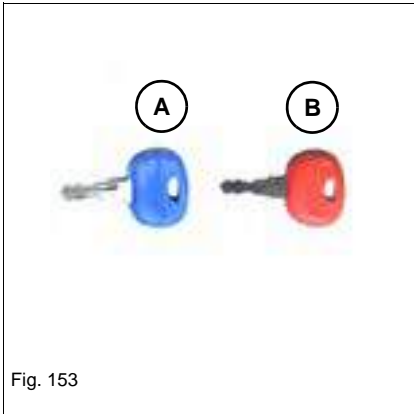

Fig. 153

A = starting key (blue)

For starting the machine. Scope of delivery includes 2 keys.

B = master key (red)

i Information

Store the master key in a safe place. It can only be used for coding new starting keys.

A new immobilizer must be installed if the master key is lost.

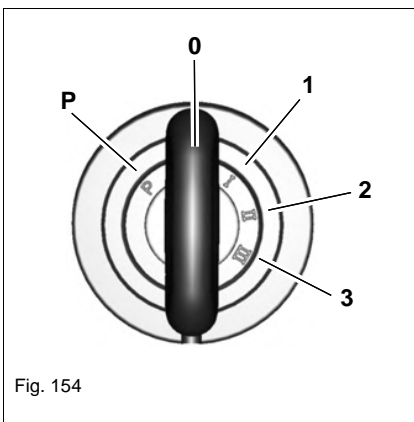

Fig. 154

The machine can be started without performing any further settings.

Coding new starting keys

1. Insert master key **B** in the starter and turn it to position **1** for a maximum five seconds.
2. Remove master key **B**.
3. Keep master key **B** at least 50 cm (19.68 in) away from the starter.
4. Within 15 seconds, turn keys requiring coding to position **1** for at least one second.
5. Repeat step 4 if more starting keys require coding.

➔ The keys are coded now.

Coding can be performed for a maximum of 10 starting keys.

i Information

The procedure is automatically cancelled if no key requiring coding is detected by the system within 15 seconds.

Deleting coded keys

Deleting all coded keys is necessary whenever a coded key is lost.

The master key code is not deleted during deletion.

1. Insert master key **B** in the starter and turn it to position **1** for at least 20 seconds.
2. Code the starting keys.

Maneuvering operation (option)

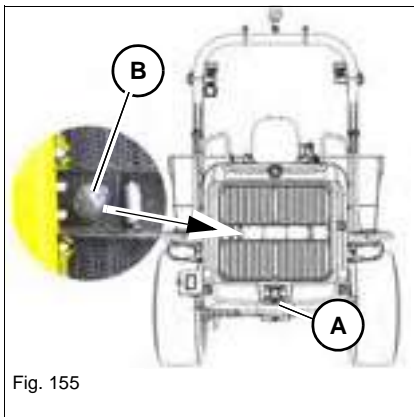

The machine is equipped with a towing gear **A**. However, it is not a tractor vehicle and may not be used as such in difficult terrain.

- If the machine is used on construction sites for towing trailers, weight the skip with 25 % of the payload. The towed equipment including the weight in the skip may not exceed the machine's payload.
- Secure the towing pin of the towing gear with a split pin.
- Counterweights affect handling and the machine's steering capability.
- and couple them only with the specially required towing gear.
- Secure the trailer to prevent it from rolling away (for example with wheel chocks, blocks).
- During maneuvering operation, check whether all lights and indicator lights are functional. Socket **B** is installed at the upper left of towing gear **A** to ensure power supply for additional equipment.

i **Information**

Observe the national and regional regulations.

5.14 Putting out of operation/back into operation

The specified measures refer to putting the machine out of operation and back into operation after more than 30 days.

Putting out of operation temporarily

Store the machine indoors if possible.

Park the machine only on firm ground (for example concrete) outdoors. Tilt the skip to prevent material from freezing or ice from forming in the skip.

1. Park the machine – *see “Parking the machine” on page 5-15.*
2. Clean the engine with a high-pressure cleaner in a suitable place – *see chapter “7.5 Cleaning and maintenance” on page 7-16.*
3. Check the machine for leaks and loose nuts, screws and connections.
4. Carefully clean and dry the entire machine.
5. Spray an anticorrosion agent onto bare metal parts of the machine (piston rods of hydraulic cylinders, for example).
6. Apply grease to all lubrication points.
7. Fill the fuel tank completely.
8. Check the hydraulic oil, antifreeze and coolant levels, and add hydraulic oil, antifreeze and coolant if necessary.
9. Change engine oil.
10. Operate the battery master switch.
11. Remove the battery and store it in a safe place. Charge the battery and perform battery maintenance at regular intervals.
12. Close the air-intake openings of the air filter system and exhaust pipe.

Putting back into operation

Information

If the machine was out of operation over a longer period of time without performing the specified steps, contact a Wacker Neuson service center before putting back into operation.

1. Perform a general visual check of the damage on the electric cables, connectors, fuel lines, corrosion, etc. on the engine and particulate matter catalyst.
 2. Start the engine once a month to ensure optimal lubrication.
 3. Remove anticorrosion agents from bare metal parts.
 4. Charge, install and connect the battery.
 5. Open the air-intake openings of the air filter system and exhaust pipe.
 6. Check the condition of the air filter elements and have them replaced by a Wacker Neuson service center if necessary.
 7. Bleed the fuel system – *see chapter “Bleeding the fuel system” on page 7-22.*
 8. Check the machine for leaks.
 9. Lubricate the machine according to the lubrication plan.
 10. Check all engine/machine fluids in the units or reservoirs, and add fluids if necessary.
 11. If the machine was out of service for over six months, change the oil in the gearbox, engine, hydraulic oil reservoir and other units.
 12. Have the hydraulic oil filters (return and breather filters) replaced by a Wacker Neuson service center if the machine was out of operation for over six months.
 13. Switch on the starter and check whether there are any malfunctions – *see chapter “8.1 Engine warning lights” on page 8-1.* In case of malfunctions, contact a Wacker Neuson service center and have the malfunction rectified.
 14. Start the engine.
 15. Let the engine run at idling speed at least 15 minutes without load.
 16. Stop the engine.
 17. Check the oil levels in all units and add oil if necessary.
 18. Check the machine for leaks.
 19. Start the machine and ensure that all functions and warning systems work correctly.
- Avoid operation at maximum engine speed or load for an hour.

5.15 Permanently putting out of operation

Disposal

All fluids, lubricants, material, etc., used on the machine are subject to specific regulations. Dispose of different materials and consumables separately and in an environmentally friendly manner.

Have only a Wacker Neuson service center ensure machine disposal. Observe the national guidelines regarding disposal.



Environment

Do not allow environmentally damaging wastes to get into the ground or stretches of water and dispose of them in an environmentally friendly manner.

If the machine is no longer used according to its designated use, ensure that it is put out of operation and disposed of according to national and regional regulations.

- Machine disposal must be performed in accordance with state-of-the-art standards that apply at the time of disposal.

6 Transportation

6.1 Towing the machine

 **WARNING****Accident hazard due to incorrect towing!**

Incorrect towing can cause accidents and serious injury or death.

- ▶ Tow the machine away only from the immediate danger zone until it can be loaded.
- ▶ Never tow downhill.
- ▶ Only tow the machine using suitable towing equipment in connection with suitable towing facilities, such as a towing hooks, eyes, etc.
- ▶ There must be nobody between the vehicles during towing. The lateral safety distance is equal to 1.5 times the length of the towing equipment.
- ▶ Do not tow the machine if it is stuck or on a slope. Load the machine.
- ▶ The machine cannot be steered when the hydraulic oil reservoir is empty.
- ▶ Allow the traveling drive to cool down.
- ▶ Wear protective equipment.
- ▶ Start machine travel and tow away slowly.

 **WARNING****Burn hazard due to hot surfaces!**

Higher towing speeds and longer towing distances cause significant heat to develop. This can cause serious injury or death.

- ▶ Only tow the machine out of the immediate danger zone until it can be loaded. Do not tow the machine farther than 20 meters (66 ft).
 - ▶ Tow the machine as slowly as possible – under no circumstances faster than walking speed.
 - ▶ Wear protective equipment.
-

! WARNING

Crushing hazard due to machine rolling away under its own weight after parking it!

Serious injury or death can be caused by not securing the machine.

- ▶ The machine may only be towed on level ground or uphill.
 - ▶ Secure the machine at the tie-down points with slings of sufficient dimensions.
 - ▶ Secure the machine with chocks to prevent it from rolling.
-

NOTICE

The machine can be damaged during towing.

- ▶ Tow the machine away only from the immediate danger zone until it can be loaded.
 - ▶ Do not tow the machine if it is stuck or on a slope. Load the machine.
 - ▶ Only tow the machine using suitable towing equipment in connection with suitable towing facilities, such as a towing hooks, eyes, etc.
 - ▶ A tractor vehicle of the same weight category must be used as a minimum.
In addition, the tractor vehicle must be equipped with a safe braking system and sufficient tractive power.
-

i Information

The manufacturer's warranty shall not apply to accidents or damage caused by towing.

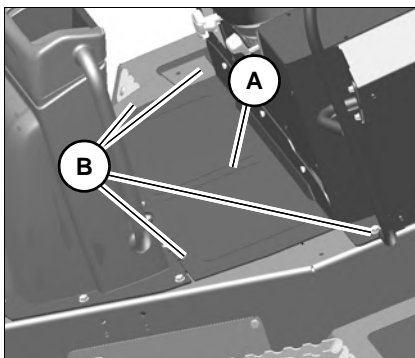

Fig. 156

1. Apply the parking brake.
2. Secure the machine with chocks to prevent it from rolling.
3. Remove rubber mat **A**.
4. Remove screws **B**.

Disabling the pressure limiting valves

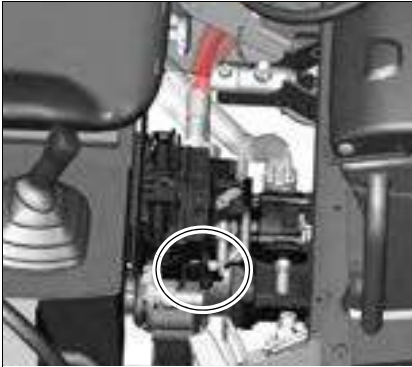

Fig. 157

Clean the area around the pressure limiting valves.

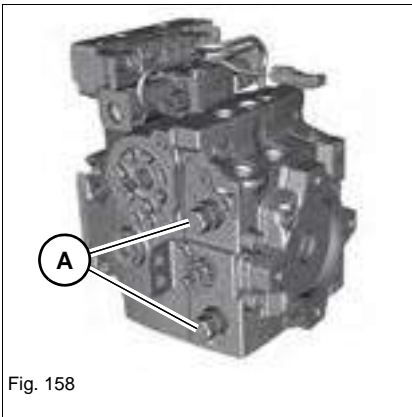

Fig. 158

Loosen screws **A** with exactly 3 revolutions.

Disabling the hydraulic parking brake

WARNING

Burn hazard due to hot surfaces!

Can cause serious burns or death.

- ▶ Stop the engine and let it cool down.
- ▶ Wear protective equipment.

NOTICE

Higher towing speeds and longer towing distances may cause severe damage to the machine.

- ▶ Tow the machine away only from the immediate danger zone.
- ▶ Do not tow the machine farther than 20 meters (66 ft).
- ▶ Wear protective equipment.

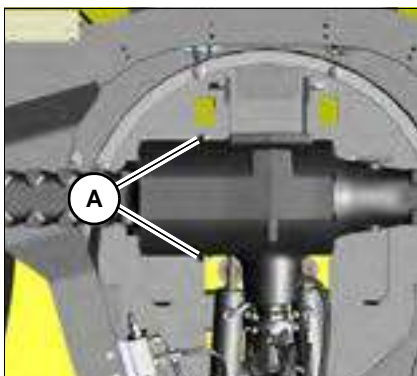

Fig. 159

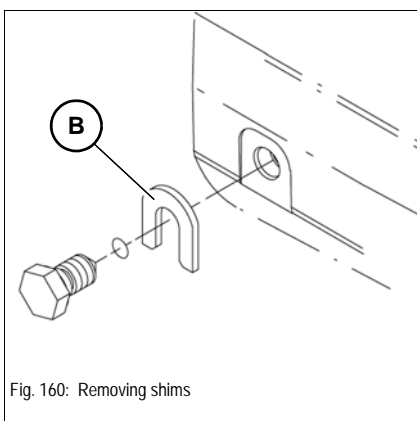

Fig. 160: Removing shims

1. Secure the machine with chocks to prevent it from rolling.
2. Secure the machine at the tie-down points with slings of sufficient dimensions.
3. Loosen unlocking screws **A** on the front axle.

4. Remove shims **B** on either side
5. Screw in the unlocking screw **A** alternately as far as they will go.
 - ▶ The hydraulic parking brake is disabled.
6. Perform towing.

Once towing is over, have repair work performed by an authorized service center.

Towing the machine on public roads

Do not tow other vehicles with the dumper, nor must the dumper be towed with another vehicle.

6.2 Loading the machine

WARNING

Accident hazard due to incorrect loading!

Incorrect loading can cause accidents and serious injury or death.

- ▶ Do not allow anyone to stay in the danger zone.
- ▶ Read the transport weight off the type label. Add the weight of subsequently installed equipment to the weight of the machine.
- ▶ Get off a transport vehicle only with the help of a person guiding you.

Tie-down points



Position	Position	Quantity
A	At front of skip	1
B	Operator's compartment on left and right	2
C	At rear left and right of machine	2

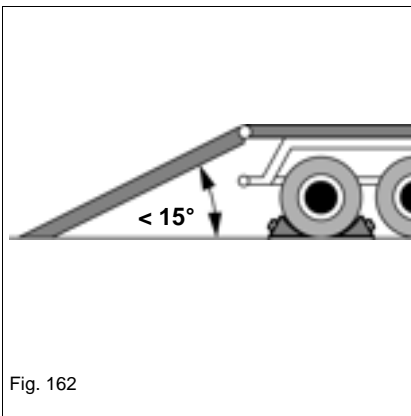

Preparations

1. – see chapter “2.9 Trailering and Transport” on page 2-12
2. Secure the transport vehicle with chocks to prevent it from rolling.
3. Position the ramps at the smallest possible angle. Ensure that the grade does not exceed 15° (27 %).
4. Use access ramps and transport surfaces with an antiskid surface only.
5. Ensure that the loading area is clear and access to it is not obstructed, for example by superstructures.

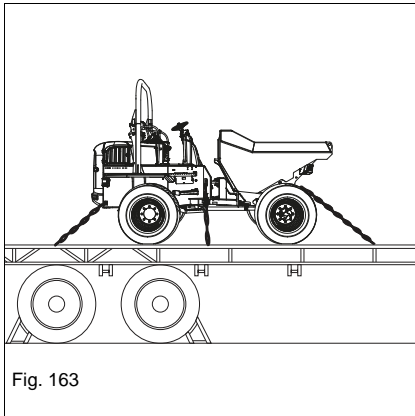

6. Start the engine.
7. Lower the skip.
8. Carefully travel the machine backward onto the middle of the transport vehicle.
9. Move the machine to transport position.
10. Apply the parking brake.
11. Stop the engine.
12. Remove the starting key and carry it with you.
13. Leave the control stand. If the machine is equipped with a cabin (option), close and lock the door, windows and all covers.

Center-pivot prop

WARNING

Crushing hazard due to machine steered via the articulation!

Can cause serious injury or death.

- ▶ Install the center-pivot prop before lifting the machine.

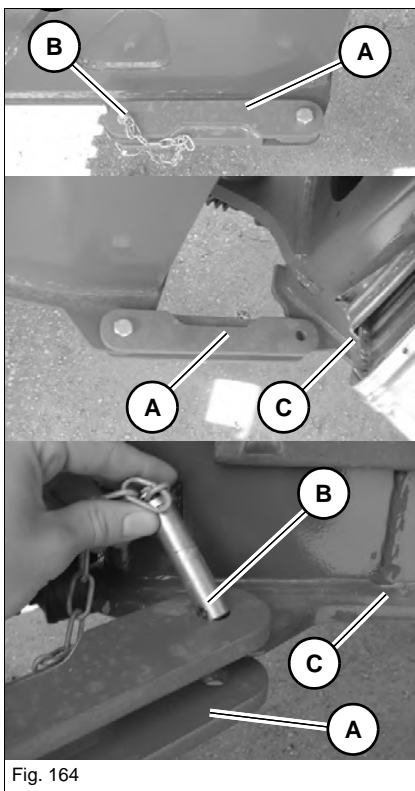

The center-pivot prop prevents the machine from being steered.

1. Remove pin **B**.
2. Rotate center-pivot prop **A** toward rear chassis **C**.
3. Insert pin **B**.

Information

Install the center-pivot prop back onto the front chassis before putting the machine into operation again.

Lifting

WARNING

Accident hazard due to incorrect loading!

Incorrect loading can cause accidents and serious injury or death.

- ▶ Do not allow anyone to stay in the danger zone.
 - ▶ Read the transport weight off the type label. Add the weight of subsequently installed equipment to the weight of the machine.
 - ▶ The machine may only be raised with suitable lifting gear.
-

Information

Use OSHA-rated and approved lifting devices capable lifting the machine, attachments, options and accumulated debris. Refer to the general weight guidelines in the specification section of this manual.

Do not attempt to lift the machine with any type of crane including wheel loaders unless the crane operator is qualified to lift loads in craning operations. The crane operator shall be knowledgeable of OSHA 1910 craning regulations.

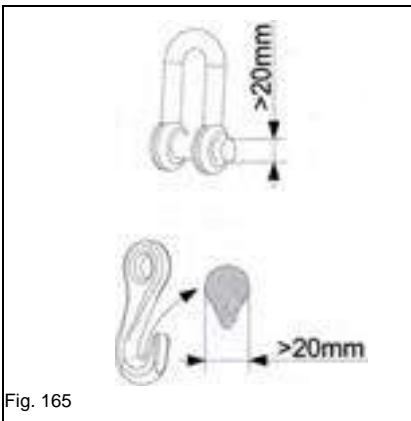

Fig. 165

NOTICE

Possible damage to lifting eyes due to wrong lifting gear.

- ▶ For lifting the machine, use only hooks or shackles with a minimum diameter of 20 mm (0.79 in).
-

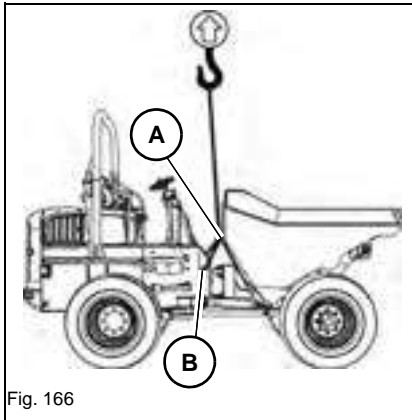

Fig. 166

1. Empty the skip and lower it to middle position.
2. Remove all dirt from the machine.
3. Park the machine on firm, level and horizontal ground.
4. Lock the control lever – *see chapter “Enabling/disabling the operating hydraulics” on page 5-10.*
5. Stop the engine.
6. Remove the starting key and carry it with you.
7. Machine with optional cabin:
 - Safely store all loose objects.
 - Close and lock all covers and the door.
8. The rollbar can be lowered to reduce the transport height – *see chapter “Rollbar” on page 4-13*
9. Put the center-pivot prop in place – *see “Center-pivot prop” on page 6-6.*
10. Use suitable lifting gear (chain, etc.).
11. Put the lifting gear through bracket **A** on the edge of the skip and fasten it on lifting eyes **B** on the left and right on the chassis with suitable slings.
12. Slowly raise the machine until there is no more contact with the ground.
13. Wait until the machine does not swing any more.
14. If the machine balance, and the condition and position of the slings is correct, slowly raise the machine to the required height and load it.

i Information

The manufacturer's warranty shall not apply to accidents or damage caused by loading or transporting.

6.3 Transporting the machine

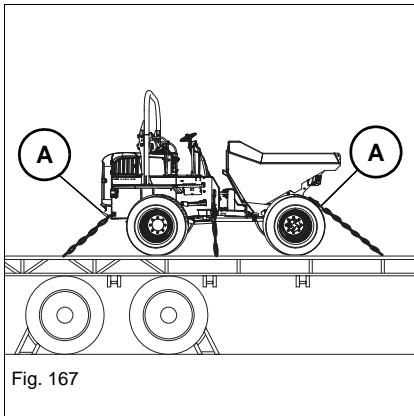

1. Install the center-pivot prop.
2. Firmly fasten the machine on the loading area with tie-down points **A** with slings of appropriate size. Observe the legal regulations.
3. Before transporting the machine through wet weather:
Close the exhaust pipe.
4. The driver of the transport vehicle must observe the following before departure:
 - Permitted overall height, width and weight of the transport vehicle including the dumper.
 - The legal regulations of the countries where transport is to take place.

i **Information**

Only use OSHA-approved lifting devices.

Use edge protectors to avoid damage both to the machine and the OSHA-approved lifting devices.

i **Information**

The manufacturer's warranty shall not apply to accidents or damage caused by loading or transporting.

Notes:

7 Maintenance

7.1 Information on maintenance

Responsibilities and prerequisites

The working order and the service life of machines are heavily dependent on maintenance.

Daily and weekly servicing and maintenance must be performed by specifically trained personnel.

Have the maintenance, delivery inspection and the entries in the service booklet performed by a Wacker Neuson service center, otherwise warranty claims will not be acknowledged. It is therefore in the interest of the machine owner to perform the mandatory maintenance. This ensures optimal machine operation.

Immediately repair or replace parts that are already damaged or not working correctly before they are due for replacement.

Have repair or replacement of safety-relevant parts performed only by a Wacker Neuson service center.

Use only original spare parts for repairs.

The manufacturer shall not be liable for damage to the machine or personal injury caused by failure to observe the specific information and descriptions.

Important safety instructions on maintenance

- Follow all safety instructions given in this Operator's Manual.
- Follow the instructions given in chapter **Safety, safety instructions on maintenance** and **qualification of the operating and maintenance personnel** in this Operator's Manual.
- Wear protective equipment (for example hard hat, safety glasses, protective gloves, safety boots).
- Observe the danger indications and safety instructions during maintenance.
- In order to avoid injury hazard, do not perform work on a hot and running engine.
- Use a suitable container to collect fluids and lubricants as they flow out and dispose of them in an environmentally friendly manner.
- Attach a warning label to the control elements (for example "**Machine being serviced, do not start**").
- Stop and park the machine. Stop the engine – see "[Preparing lubrication](#)" on page 7-8.
- In order to avoid damage to electronic components, do not perform welding work on the machine. Contact a Wacker Neuson service center.
- High engine load or a manual regeneration of the particulate matter catalyst can lead to shorter engine oil maintenance intervals. Output is reduced if the machine is used beyond the maintenance interval. If the machine is operated less than 500 hours per year the engine oil must be changed once a year.

7.2 Maintenance overview

Maintenance label

Maintenance that has to be performed by the operator is indicated on the maintenance label.

DW60 62.5 kW (83.8 hp)

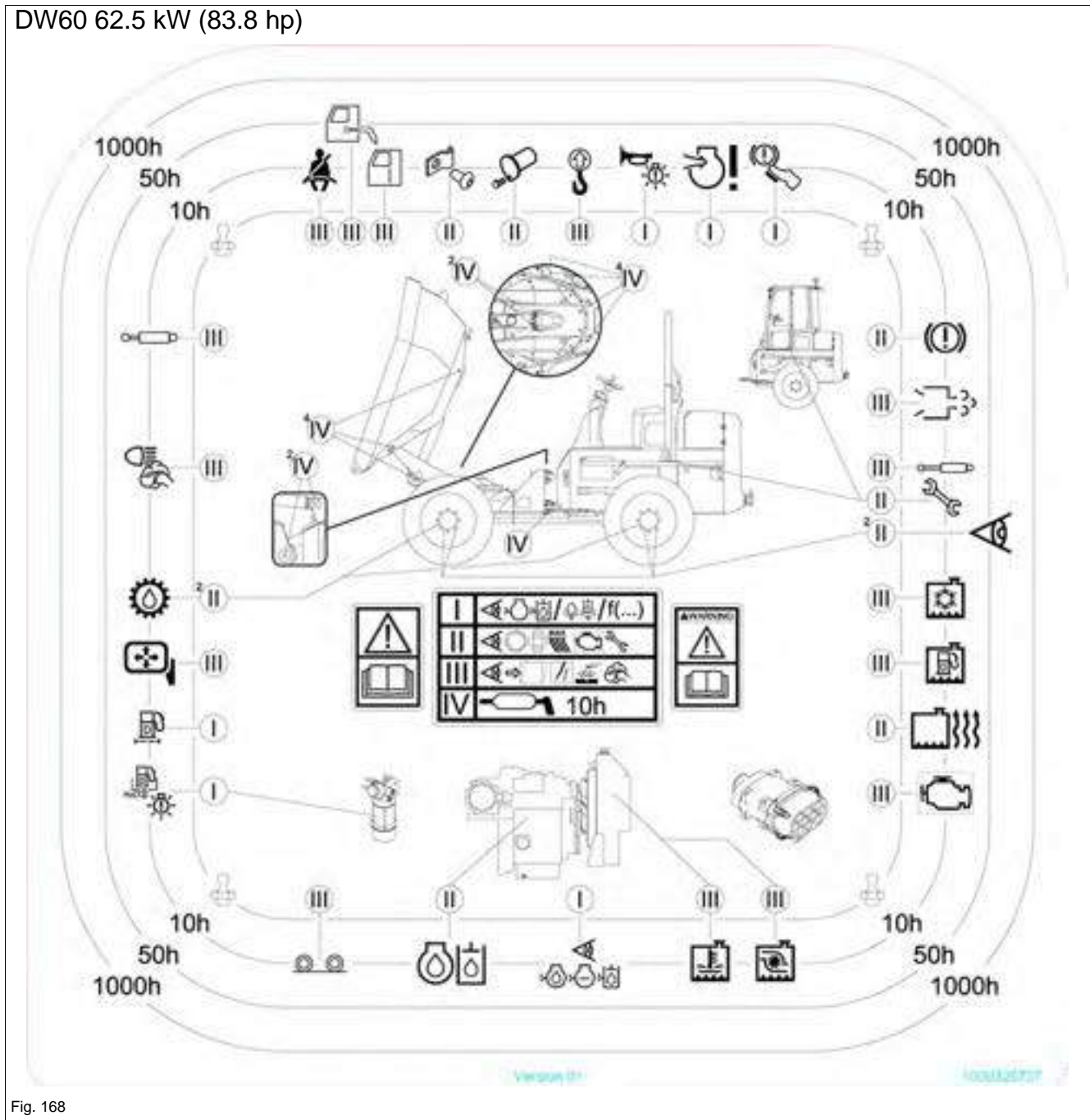

Fig. 168

- I Checking functions and levels, filling up and draining
 - II Checking wear parts, seals, hoses and threaded fittings
 - III Checking for damage, corrosion and dirt
 - IV Lubricate daily after the work shift
- Superscript numbers, for example ²: number of lubrication points

Maintenance that has to be performed by the operator is indicated on the maintenance label.

DW60, DW90, DW100 55 kW (73.8 hp)

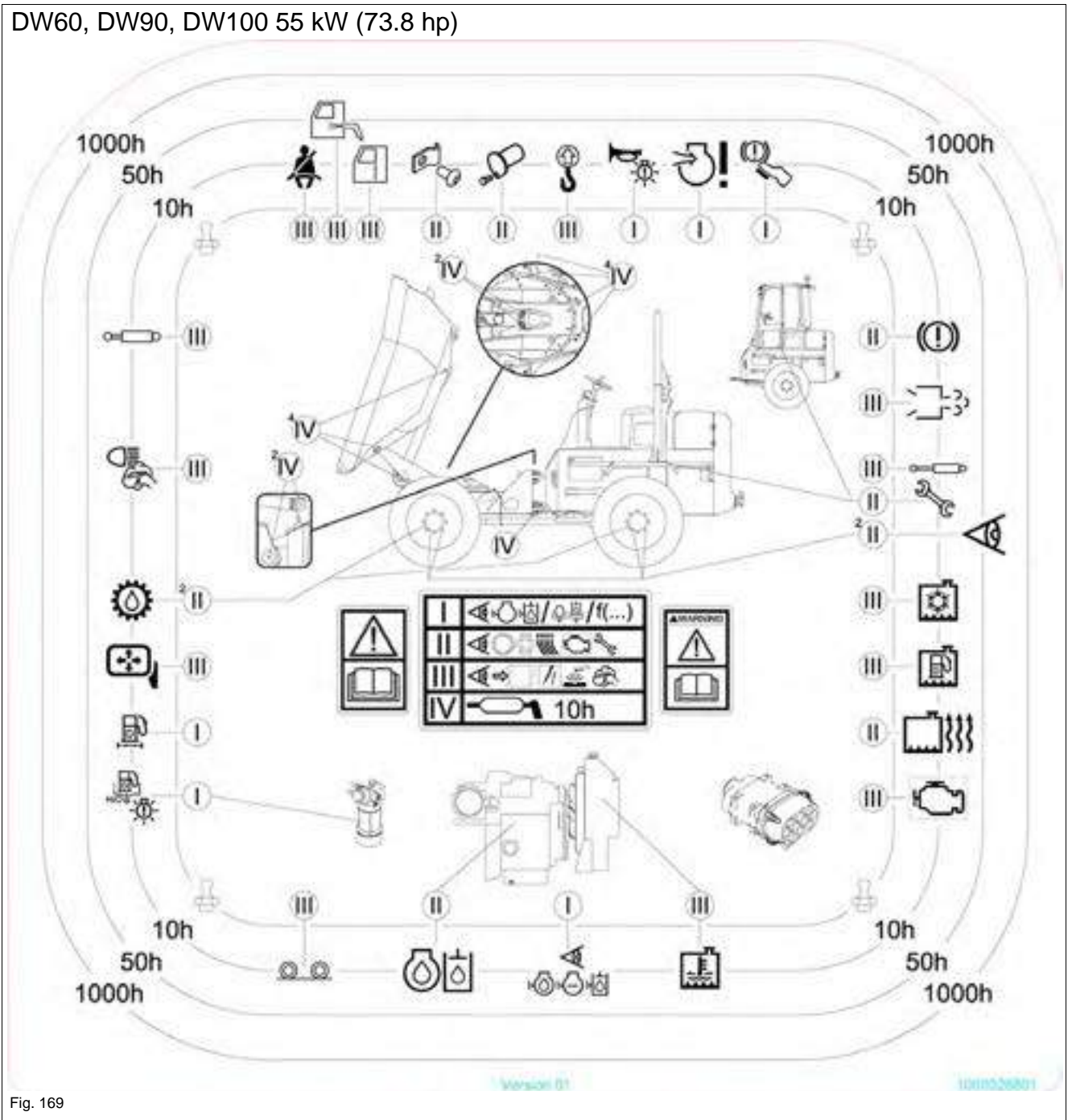

Fig. 169

- I Checking functions and levels, filling up and draining
 - II Checking wear parts, seals, hoses and threaded fittings
 - III Checking for damage, corrosion and dirt
 - IV Lubricate daily after the work shift
- Superscript numbers, for example ²: number of lubrication points

Maintenance that has to be performed by the operator is indicated on the maintenance label.

DW60, DW90, DW100 86 kW (115.3 hp)

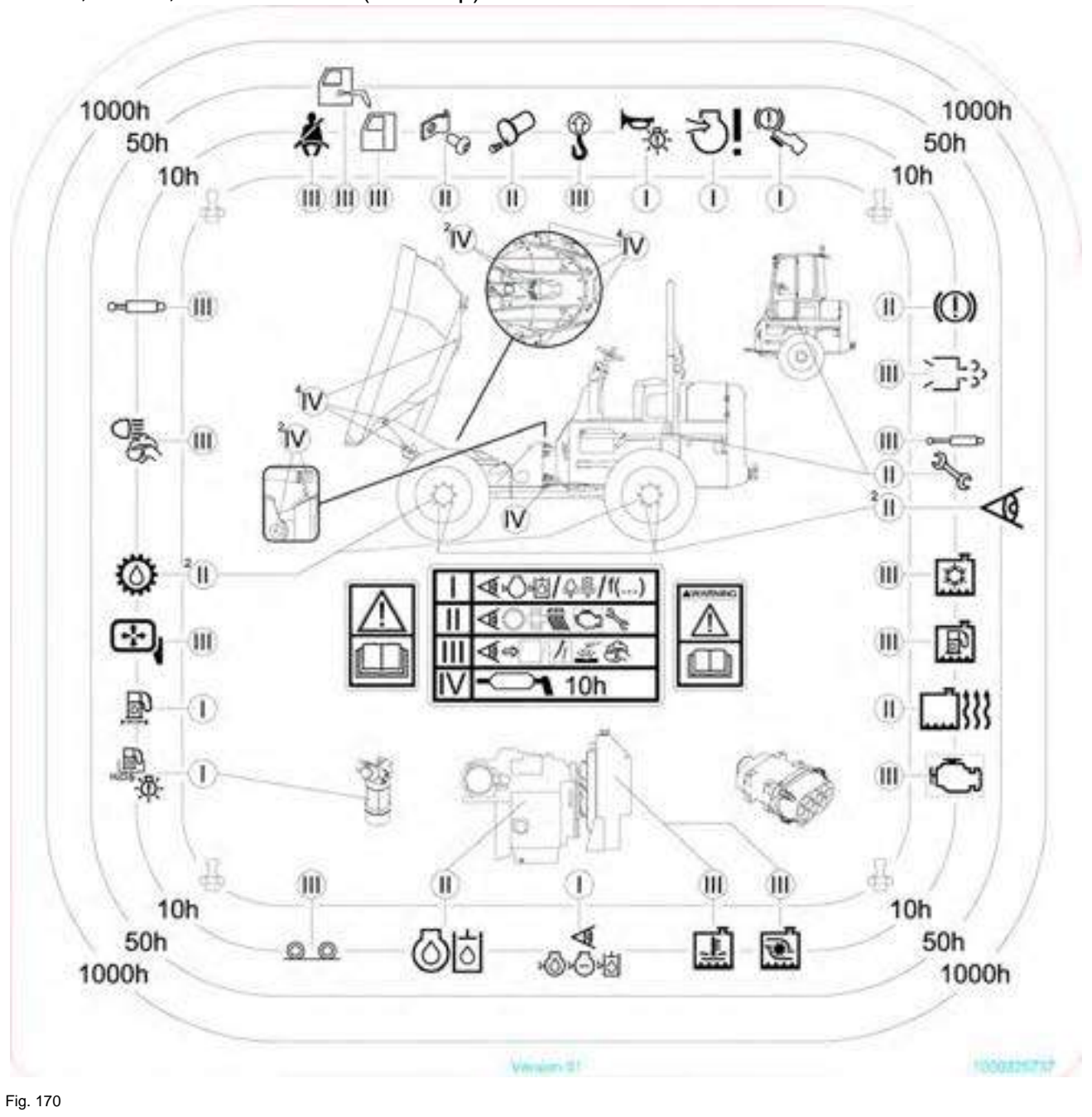































Fig. 170

- I Checking functions and levels, filling up and draining
 - II Checking wear parts, seals, hoses and threaded fittings
 - III Checking for damage, corrosion and dirt
 - IV Lubricate daily after the work shift
- Superscript numbers, for example ²: number of lubrication points

Maintenance plan

Daily maintenance (operator)		
Symbol	Inspection work (Check the following engine/machine fluids. Check the oil levels after a test run and add oil if necessary.)	Page
	Check the engine/machine fluids (engine oil, engine coolant, hydraulic oil, brake fluid)	7-26, 7-29, 7-34
	Check the radiator for dirt, clean it if necessary	7-30
	Check the charge-air cooler for dirt, clean it if necessary (only for 86 kW / 115.3 hp)	7-30
	Check the fuel radiator for dirt, clean it if necessary	7-30
	Lubricate the machine according to the lubrication plan	7-9, 7-9
	Check the water separator (prefilter) and the fuel filter at the sight glass (62.5 kW / 83.8 hp): drain water if necessary Interval according to indication for 55 kW (73.8 hp) and 86 kW (115.3 hp)	7-23
	Check the tires (damage, inflation pressure, tread depth)	7-40
	Check the engine air intake	7-32
	Check the pin locks	--
	Check line fixtures	--
	Check the indicator lights and acoustic warning devices	4-24
	Check the service and parking brake function	5-5
	Check the threaded fittings of the protective structures (for example the cabin, rollbar) for tightness	7-18
	Clean the lights/light system, signaling systems	--
Option		
	Adjust the mirrors correctly, clean them and check them for damage, check the fastening screws and tighten them if necessary	4-33

Daily maintenance (operator)		
	Check the condenser for dirt, clean it if necessary	7-30
Leakage check		
Check for tightness, leaks and chafing: pipes, flexible lines and threaded fittings of the following assemblies and components. Have them repaired if necessary.		
	Engine and hydraulic system	--
	Traveling drive, axles and transfer gearbox	--
	Braking system	
	Cooling systems, heating and hoses (visual check)	--
Visual check		
Check for correct function, deformations, damage, surface cracks, wear and corrosion.		Page
	Check the exhaust system for damage	--
	Check the insulating mats in the engine compartment for damage	--
	Check the cabin and protective structures for damage (for example the FOPS structure)	--
	Check the piston rods of the cylinders for damage	--
	Check the seat belt for damage	7-18
	Check the lifting eyes	--

Weekly maintenance (every 50 operating hours) (operator)		Page
All steps for previous maintenance intervals		--
	Lubricate the machine according to the lubrication plan	7-9, 7-19
	Check the axle mounting for tightness (visual check)	--
	Check the wheel nuts for tightness (visual check)	7-40
	Check accesses and exits for dirt	--
	Replace the air filter ¹	7-32

1. Air filter replacement according to the indicator light, every 1000 o/h or once a year at the latest. (Replace after 50 o/h when in extensive use in environments with acidic air, such as acid production facilities, steel and aluminum mills, chemical plants and other nonferrous-metal plants, independently of the indicator light. Contact a Wacker Neuson service center.)

Only once after the first 50 operating hours (Wacker Neuson service center)	Page
Replace the oil filter of the machine-travel hydraulics	--
Replace the oil filter of the operating hydraulics	--
Replace the gearbox oil in the traveling drive, axles and transfer gearbox	--
Check V-belt condition and tension (Tier III only)	--
Check the threaded fittings for tightness	--
Check labels and Operator's Manual for completeness and condition	--
Check the pressure of the primary pressure limiting valves	--
Retighten the axle mounting	--
Retighten the wheel nuts	--
Reset the maintenance meter	--
All steps for maintenance once a day and once a week	--

Other maintenance intervals (Wacker Neuson service center):

- Every 500 operating hours or annually
- Every 1000 operating hours
- Every 1500 operating hours
- Every 2000 operating hours
- Every 3000 operating hours



Information

Maintenance with the note **Wacker Neuson service center** must be performed only by the trained and qualified personnel of a Wacker Neuson service center.

Preparing lubrication

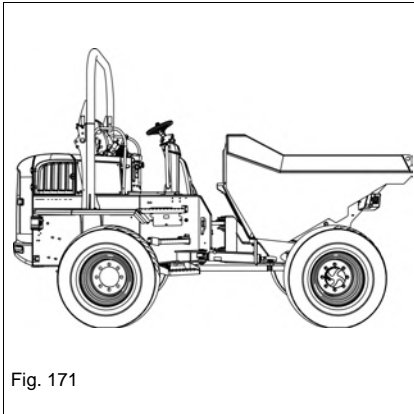

Fig. 171

1. Stop the machine on firm, level and horizontal ground.
2. Lower the skip. Check the middle position if the machine is equipped with a swivel skip [see page 5-27 "Middle position of swivel skip."](#)
3. Stop the engine.
4. Remove the starting key and carry it with you.
5. Safely store all loose objects.
6. Close the windows and doors (cabin option).
7. Close and lock all covers.
8. Attach a warning label to the control elements (for example "**Machine being serviced, do not start**").

Wait at least 10 minutes after stopping the engine.



Information

Keep all lubrication points clean and remove any escaping grease.

Lubrication plan

Lubricate the specified lubrication points once a day. Before starting maintenance, lower the red maintenance prop when the skip is raised and secure the skip with it.

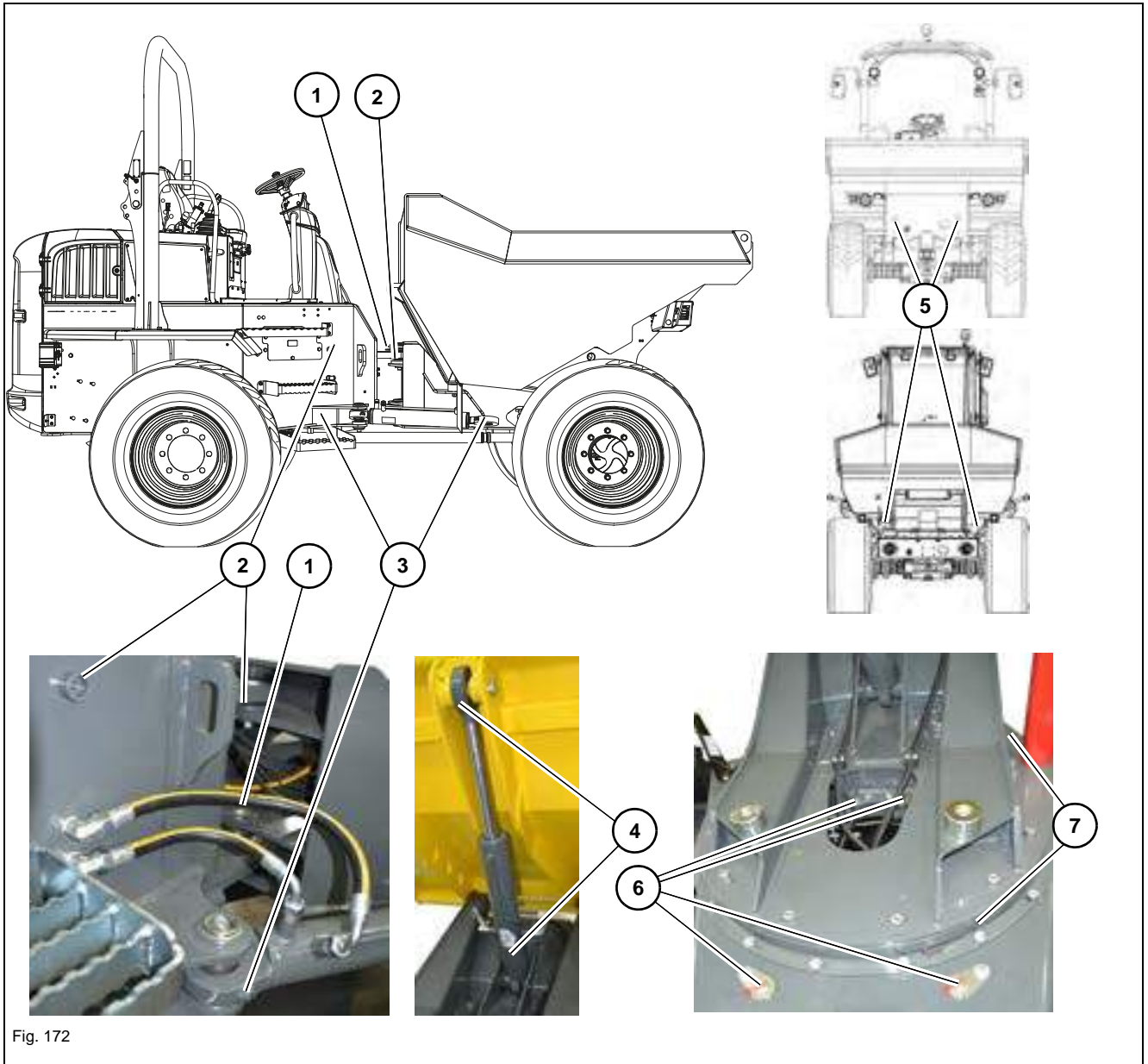

Fig. 172

Position	Lubrication point	Quantity
1	Articulated joint on left and right	2
2	Articulated joint (left side of joint, right side of machine)	2
3	Front and rear of steering cylinder	2
4	Top and bottom of steering cylinder	2
5	At front of skip	2
6	Swiveling cylinder ¹	4
7	Live ring ¹	4

1. Option for swivel skip

7.3 Fluids and lubricants

Application	Fluid/lubricant	Specification	Season/temperature	Capacities ¹
Engine (Tier III/Tier IV) ²	Diesel fuel	ASTM D975 grade 2D S15 (USA) ^{3,4}	Summer or winter diesel depending on outside temperatures	83 l (21.9 gal)
		EN 590 (EU) ^{4,5}		
		BS 2869:2010 class A2 (GB) ^{4,5}		
	Coolant	Distilled water and anti-freeze ASTM D6210	Year-round	16 l (4.2 gal)
Engine (Tier III)	Engine oil ⁶	API CH-4	-20 °C to +40 °C (-4 °F to 104 °F)	8.0 l (2.1 gal)
		ACEA E5		
		EMA-DHD-1		
Engine (Tier IV)	Engine oil ²	API CJ-4	-18 °C to +50 °C (0 °F to 122 °F)	7.2 l (1.9 gal)
		ACEA E9		
		ECF-3		
Hydraulic oil reservoir	Hydraulic oil	Eurolub HVLP 46 ⁷	Year-round ⁸	60 l (15.9 gal)
	Biodegradable hydraulic oil ⁹	Panolin HLP Synth 46		
Brake fluid	Hydraulic oil	Eurolub HVLP 46 ⁷	Year-round ⁸	200 ml (12.2 in ³)
Grease zerks	Grease	KPF 2 K-20 ¹⁰ ISO-L-X-BCEB 2 ¹¹	Year-round	As required
Battery terminals	Acid-proof grease ¹²	FINA Marson L2	Year-round	As required
Washer system	Cleaning solution	Glass cleaner and anti-freeze	Year-round	1.2 l (73 in ³)

- The capacities indicated are approximate values; the oil level check alone is relevant for the correct oil level.
Capacities indicated are no system fills
- Using biodegradable diesel fuel is prohibited.
- Tier III diesel engine: In countries without regulations on exhaust-gas emissions, diesel fuel with a sulfur content of up to 4000 ppm (0.4 %) can be used.
- Sulfur content up to 15 ppm (0.0015 %)
- Sulfur content up to 10 ppm (0.001 %)
- According to DIN 51511
- According to DIN 51524 section 3, ISO-VG 46
- Depending on local conditions – see “[Engine oil types](#)” on page 7-11
- Biodegradable hydraulic oil based on saturated synthetic esters with an iodine value of < 10, according to DIN 51524, section 3, HVLP, HEES
- According to DIN 51502, lithium-saponified grease
- According to DIN ISO 6743-9, lithium-saponified grease
- Standard acid-proof grease NGLI category 2

Engine oil types

Tier III engine				
Viscosity grade	Ambient temperature			
EMA LRG-1; API CH-4	min. °C	min. °F	max. °C	max. °F
SAE 0W20	-40	-40	10	50
SAE 0W30	-40	-40	30	86
SAE 0W40	-40	-40	40	104
SAE 5W30	-30	-22	30	86
SAE 5W40	-30	-22	40	104
SAE 10W30	-20	-4	40	104
SAE 15W40	-10	14	50	122

Tier IV engine				
Viscosity grade	Ambient temperature			
API CJ-4; ACEA E9; ECF-3	min. °C	min. °F	max. °C	max. °F
SAE 0W30	-30	-22	30	86
SAE 0W40	-30	-22	40	104
SAE 5W30	-25	-13	30	86
SAE 5W40	-25	-13	50	122
SAE 10W30	-18	0	40	104
SAE 10W40	-18	0	50	122
SAE 15W40	-10	14	50	122

Hydraulic oil types

Hydraulic oil types				
Viscosity grade	Ambient temperature			
HVLP 46¹	min. °C	min. °F	max. °C	max. °F
ISO VG32	-20	-4	30	86
ISO VG46	-5	23	40	104
ISO VG68	5	41	50	122

1. According to DIN 51524 section 3, ISO-VG 46.

Important information regarding operation with biodegradable hydraulic oil

- Use only the biodegradable oils that have been tested and released by Wacker Neuson.
- Add only biodegradable oil of the same type. In order to avoid misunderstandings, attach a label on the hydraulic oil filler inlet providing clear information regarding the type of oil currently used.
The joint use of two different biodegradable oils can affect the quality of one of the oil types. Therefore ensure that the remaining amount of biodegradable oil complies with the national and regional regulations as you replace it. Observe the manufacturer's indications.
- Do not add mineral oil – the content of mineral oil should not exceed 2 % of the system fill in order to avoid foaming problems and to ensure biological degradability.
- When running the machine with biodegradable oil, the same oil and filter replacement intervals are valid as for mineral oil.
- Always have the condensation water in the hydraulic oil reservoir drained by a Wacker Neuson service center before the cold season. The water content may not exceed 0.1 % by weight.
- The instructions in this Operator's Manual concerning environmental protection are also valid for the use of biodegradable oil.
- Subsequent change from mineral oil to biodegradable oil may only be performed by a Wacker Neuson service center.

7.4 Maintenance accesses

 **WARNING****Burn hazard due to hot surfaces!**

Can cause serious burns or death.

- ▶ Stop the engine and let hot surfaces cool down.
 - ▶ Wear protective equipment.
-

 **WARNING****Injury hazard due to rotating parts!**

Rotating parts can cause serious injury or death.

- ▶ Open the maintenance flap only at engine standstill.
-

 **CAUTION****Injury hazard due to open maintenance access!**

Can cause injury.

- ▶ Take care to avoid injuries when the maintenance access door is open.
-

Maintenance flaps

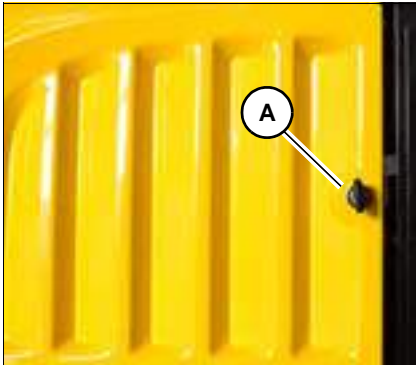

Fig. 173

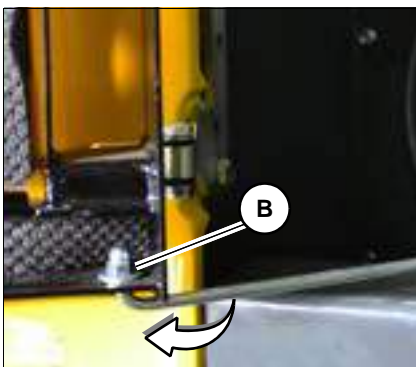

Fig. 174

Unlocking and locking

Function	Operation
Open the maintenance flap	Turn the starting key in lock A toward the rear of the machine
Lock the maintenance flap	Turn the starting key in lock A toward the skip

Open

Unlock the maintenance flap and open it completely until lock **B** engages. This secures it against unintentional closing.

Close

Slightly press the maintenance flap backward and at the same time, raise lock **B**. Lock the maintenance flap.

Fan grid



Fig. 175

The water/hydraulic oil radiator, the fuel cooler and the charge-air cooler (only machines with 86 kW / 115.3 hp engine) are located behind the fan grid. In order to avoid overheating, check the fan grid regularly for dirt and clean it if necessary – see [“Cleaning the radiator” on page 7-30](#).

Fuse box

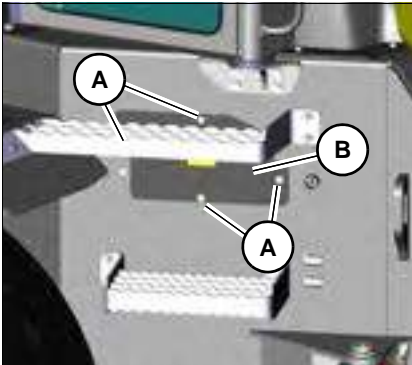

Fig. 176

The fuse box is located at the front right of the chassis.

Function	Operation
Opening the fuse box	Remove screws A and cover B
Close the fuse box	Install cover B and tighten screws A

Description of fuses – see chapter “Fuse box” on page 9-6

Battery case

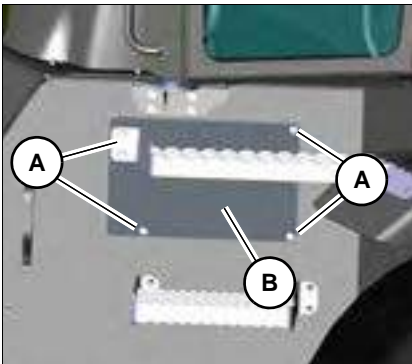

Fig. 177

The battery case is located at the front left on the chassis.

Function	Operation
Open the battery case	Remove screws A and cover B
Close the battery case	Install cover B and tighten screws A

7.5 Cleaning and maintenance

WARNING

Injury hazard due to rotating parts!

Rotating parts can cause serious injury or death.

- ▶ Open the maintenance flap only at engine standstill.
-

WARNING

Burn hazard due to hot surfaces!

Hot surfaces can cause serious burns or death.

- ▶ Stop the engine and let it cool down.
 - ▶ Wear protective equipment.
-

CAUTION

Health hazard due to cleaning agents!

Cleaning agents can be harmful to health

- ▶ Use only suitable cleaning agents.
 - ▶ Ensure sufficient ventilation.
-

NOTICE

Damage to rubber and electrical parts when cleaning with solvents.

- ▶ Do not use solvents, benzene or other aggressive chemicals.
-

NOTICE

Damage to electronics due to water jet.

- ▶ Do not point the water jet directly at electric components, and protect the electric components against humidity.
 - ▶ If water contacts electrical components, dry them with compressed air and apply contact spray to them.
-



Environment

In order to avoid damage to the environment, clean the machine only in wash bays and places provided to this effect.

Cleaning the machine is divided into three separate areas:

- Inside the cabin
- Exterior of the machine
- Engine compartment

Washing solvents

- Ensure sufficient room ventilation.
- Wear suitable protective clothing.
- Do not use flammable liquids, such as gasoline or diesel.

Compressed air

- Work carefully.
- Wear safety glasses and protective clothing.
- Do not aim the compressed air at the skin or at other people.
- Do not use compressed air for cleaning your clothing.

High-pressure cleaner

- Cover electric parts.
- Do not point the water jet directly at electric parts and damping material.
- Cover the breather filter on the hydraulic oil reservoir and the covers of the fuel tank and the hydraulic oil reservoir, etc.
- Protect the following components from moisture:
 - Electrical components (for example the alternator)
 - Control devices and seals
 - Air intake filters, etc.

Volatile and easily flammable anticorrosion agents and sprays:

- Ensure sufficient ventilation of the premises.
- Fire, open flames and smoking is prohibited.

Inside the cabin

Recommended aids:

- Broom
- Vacuum cleaner
- Moist cloths
- Brush
- Water with mild soap solution

Exterior of the machine

Recommended aids:

- High-pressure cleaner
- Steam jet

Engine compartment

1. Park the machine in a wash bay or place.
2. Stop the engine – see *“Preparing lubrication” on page 7-8.*
3. Clean the machine.

Seat belt

Always keep the seat belt clean, as coarse dirt can impair the proper functioning of the seat belt buckle.

Clean the seat belt (while it remains fitted in the machine) with a mild soap solution only. Do not use chemical agents as they can destroy the fabric.

Cleaning in a saline environment

1. Park the machine in a wash bay or place – see *“Preparing lubrication” on page 7-8.*
2. Check the machine for salt deposits or corrosion. Have corrosion removed by a Wacker Neuson service center.
3. Clean the machine with a high-pressure cleaner. Clean the machine ensuring that there are no salt deposits in places that are difficult to access.
Bear in mind the information on cleaning and maintenance.
4. Lubricate the machine according to the lubrication plan
5. Allow the machine to dry and check it again for salt deposits.

Loose threaded fittings and attachments

Retighten loose connections immediately, and have them immediately replaced by a Wacker Neuson service center if necessary.

7.6 Lubrication work

– see chapter “Preparing lubrication” on page 7-8.

7.7 Fuel system

Important information regarding the fuel system

NOTICE

Damage to injection pump due to air in the fuel system.

- ▶ Do not run the fuel tank completely dry.
-



Information

In order to prevent the formation of condensation water, fully fill up the fuel tank at the end of each working day.

Diesel fuel specification

NOTICE

Engine damage due to incorrect or dirty diesel fuel.

- ▶ Only use clean diesel fuel according to the **fluids and lubricants** list.
 - ▶ Do not use any diesel fuel with additives.
-

– see chapter “7.3 Fluids and lubricants” on page 7-10

Refueling

 **WARNING**

Explosion hazard due to flammable fuel/air mixtures!

Fuels develop explosive and flammable mixtures with air that can cause serious burns or death.

- ▶ Fire, open flames and smoking is prohibited.
 - ▶ Open tank lock carefully to release the pressure in the fuel tank.
 - ▶ Keep the maintenance area clean.
 - ▶ Do not refuel in closed rooms.
 - ▶ Do not add gasoline to diesel fuel.
 - ▶ Let the engine cool down.
-

 **CAUTION**

Health hazard due to diesel fuel!

Diesel fuel and fuel vapors are harmful to health!

- ▶ Avoid contact with the skin, eyes and mouth.
 - ▶ Seek medical attention immediately in case of accidents with diesel fuel.
 - ▶ Wear protective equipment.
-

 **CAUTION**

Fire hazard due to diesel fuel!

Diesel fuel gives off flammable vapors. This can cause injury.

- ▶ Fire, open flames and smoking is prohibited.
 - ▶ Adding gasoline is prohibited.
-

NOTICE

Do not refuel with cans in order to avoid dirt in the fuel.

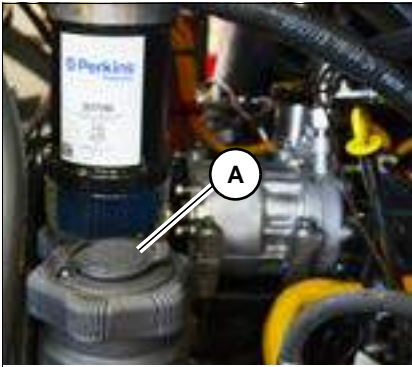

Fig. 178

Filler inlet **A** of the fuel tank is located behind the maintenance flap on the right.

1. Stop and park the machine. Stop the engine – see *“Preparing lubrication”* on page 7-8.
2. Open the maintenance flap on the right.
3. Unlock tank lock **A** with the starting key.
4. Open tank lock **A** carefully to release the pressure in the fuel tank.
5. Refuel.
6. Close and lock filler cap **A**.
7. Close and lock the maintenance flap on the right.

Stationary fuel pumps

Even the smallest particles of dirt can cause increased engine wear, malfunctions in the fuel system and reduced effectiveness of the fuel filters.

Refueling from barrels

If refueling from barrels cannot be avoided, note the following points:

- Barrels must neither be rolled nor tilted before refueling.
- Protect the suction pipe opening of the barrel pump with a fine-mesh screen.
- Immerse the suction pipe opening down to a max. 15 cm (6 in) above the bottom of the barrel.
- Only fill the tank using refueling aids (funnels or filler pipes) with integral microfilter.
- Keep all refueling containers clean.

Bleeding the fuel system

 **WARNING**

Burn hazard due to hot surfaces!

Can cause serious burns and death.

- ▶ Stop the engine and let hot surfaces cool down.
 - ▶ Wear protective equipment.
-

Bleed the fuel system in the following cases:

- After removing and fitting the fuel filter, prefilter or the fuel lines back on again.
- If the machine is put into operation after having been decommissioned for more than 30 days.

Tier III

1. Stop and park the machine. Stop the engine – see *“Preparing lubrication” on page 7-8.*
2. Fill up and close the fuel tank.
3. Turn the starting key to the first position.
4. Wait about five minutes while the fuel system bleeds itself automatically.
5. Start the engine.

If the engine runs smoothly for a while and then stops, or if it does not run smoothly:

1. Stop the engine.
2. Remove the starting key and carry it with you.
3. Bleed the fuel system again as described above.
4. Check for leaks after starting the engine.
5. Have a Wacker Neuson service center perform a check if necessary.

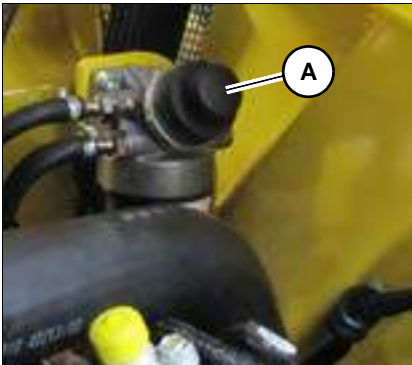

Fig. 179

Tier IV

1. Stop and park the machine. Stop the engine – see “*Preparing lubrication*” on page 7-8.
2. Open the maintenance flap on the right.
3. Unlock tank lock **A** with the starting key.
4. Open tank lock **A** carefully to release the pressure in the fuel tank.
5. Refuel.
6. Close and lock filler cap.
7. Press pump **A** several times until a firmer resistance can be felt.
8. Press pump **A** 5 x.
9. Close and lock the maintenance flap on the right.
10. Start the engine.

If the engine runs smoothly for a while and then dies, or if it does not run smoothly:

1. Stop the engine.
2. Remove the starting key and carry it with you.
3. Bleed the fuel system again as described above.
4. Check for leaks after starting the engine.
5. Have a Wacker Neuson service center perform a check if necessary.

Information

The fuel system can also be bled if the engine is warm.

Water separator

Fig. 180

The water separator is located behind the maintenance flap on the right in the engine compartment.

A water/fuel mixture is collected in the water separator during operation.

Emptying the water separator

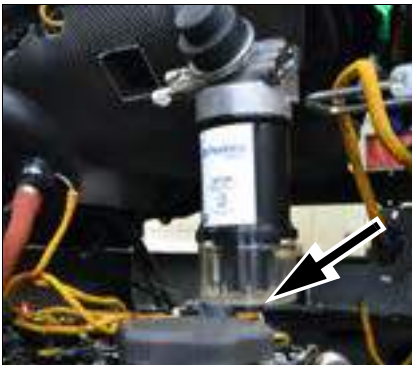
Information

Empty the water separator, if error message **SPN 97** (only Tier IV) appears in the multifunctional display.

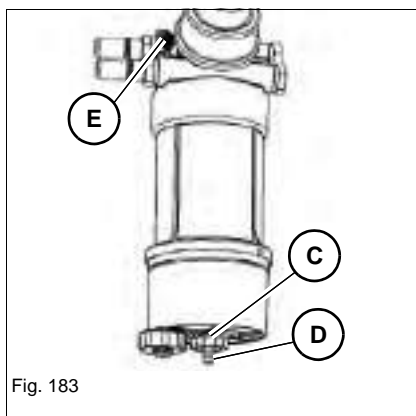
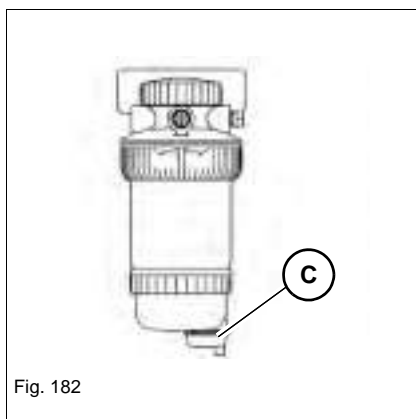
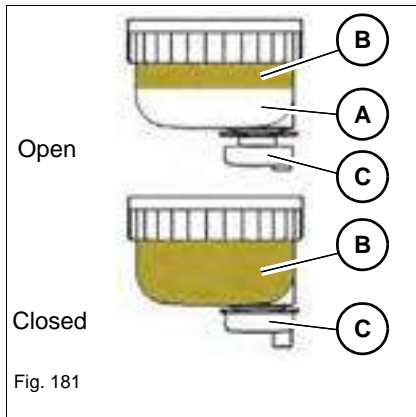

Drain the water/fuel mixture **(A)** until the sight glass contains only fuel **(B)**.

1. Stop the machine, stop the engine – see [“Preparing lubrication” on page 7-8](#).
2. Remove the starting key and carry it with you.
3. Allow the engine to cool down.
4. Open the maintenance flap on the right.
5. Place a suitable container under the water separator.

Tier III

1. Open drain valve **C**.
2. Drain the water/fuel mixture into the receptacle.
3. Close drain valve **C**.
4. Close and lock the maintenance flap on the right.

Tier IV

1. Connect a suitable hose to the drain device **D**.
2. Open drain valve **C**.
3. Loosen bleed screw **E** with a suitable tool.
 - Drain the water/fuel mixture into the receptacle.
4. Tighten bleed screw **E** with a suitable tool.
5. Close drain valve **C**.
6. Remove the hose.
7. Close and lock the maintenance flap on the right.

Environment

Use a suitable container to collect fluids and lubricants as they flow out and dispose of them in an environmentally friendly manner.

7.8 Engine lubrication system

Important information regarding the engine lubrication system

NOTICE

Possible engine damage due to incorrect engine oil level.

- ▶ The oil level must be between the MIN and MAX marks.
-

NOTICE

Damage due to wrong engine oil.

- ▶ Use engine oil according to the **Fluids and lubricants** list.
 - ▶ Have the oil changed only by a Wacker Neuson service center.
-

NOTICE

Possible engine damage due to adding engine oil too quickly.

- ▶ Add the engine oil slowly so it can go down without entering the intake system.
-

**Information**

Check the oil level once a day. Wacker Neuson recommends checking before starting the engine. Check the oil level not less than five minutes after stopping the engine.

Checking the engine oil level

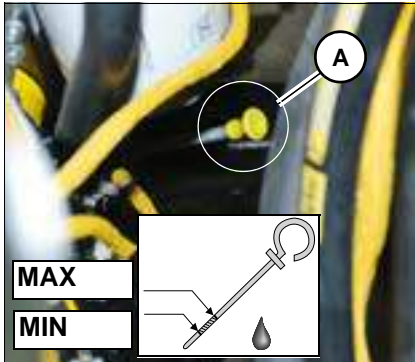

Fig. 184

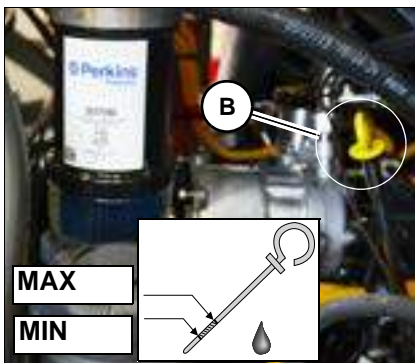

Fig. 185

1. Stop and park the machine. Stop the engine – see *“Preparing lubrication” on page 7-8.*
2. Open the maintenance flap on the right.
3. Clean the area around the oil dipstick with a lint-free cloth.
4. Pull out oil dipstick **A (Tier III)** or **B (Tier IV)** and clean it with a lint-free cloth.
5. Push oil dipstick **A** or **B** back in as far as possible.
6. Withdraw oil dipstick **A** or **B** again and read off the oil level.
 - The oil level must be between the MIN and MAX marks.
 - Add engine oil if necessary.
7. Slide in oil dipstick **A** or **B** completely.
8. Close and lock the maintenance flap on the right.

Adding engine oil



Fig. 186

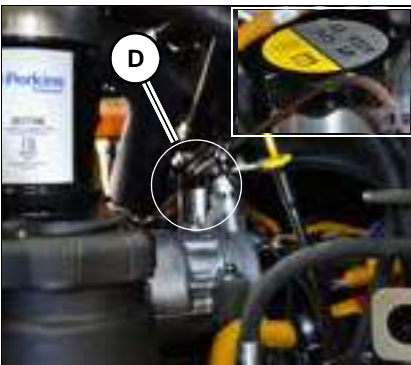

Fig. 187

1. Stop and park the machine. Stop the engine – see *“Preparing lubrication”* on page 7-8.
2. Open the maintenance flap on the right.
3. Clean the area around the oil filler cap with a lint-free cloth.
4. Open filler cap **C (Tier III)** or **D (Tier IV)**.
5. Raise oil dipstick **A** or **B** slightly to allow any trapped air to escape.
6. Add engine oil.
7. Wait 5 minutes until all the engine oil has run into the oil sump.
8. Check the oil level.
9. Add oil if necessary and check the oil level again.
10. Close filler cap **C** or **D**.
11. Push oil dipstick **A** or **B** back in as far as possible.
12. Close and lock the maintenance flap on the right.

7.9 Cooling system

Important information regarding the cooling system

 **WARNING**

Poisoning hazard due to hazardous substances!

Contact with hazardous substances can cause serious injury or death.

- ▶ Wear protective equipment.
 - ▶ Do not inhale or swallow coolant.
 - ▶ Avoid contact of the coolant or antifreeze with the skin and eyes.
-

 **WARNING**

Burn hazard due to coolant or antifreeze!

The coolant and antifreeze are easily flammable fluids that can cause serious burns or death if they are brought into contact with fire or open flames.

- ▶ Wear protective equipment.
 - ▶ Only perform maintenance on an engine that has cooled down.
 - ▶ Fire, open flames and smoking is prohibited.
-

 **WARNING**

Burn hazard due to hot coolant!

At high temperatures, the cooling system is under pressure and can cause burning of the skin.

- ▶ Wear protective equipment.
 - ▶ Let the engine cool down.
 - ▶ Carefully open the radiator cap.
-

NOTICE

Possible engine damage due to wrong coolant.

- ▶ Observe the fluid/lubricant or coolant compound table.
-

NOTICE

Possible engine damage due to low coolant level.

- ▶ Check the coolant level once a day.
-

Checking the coolant level

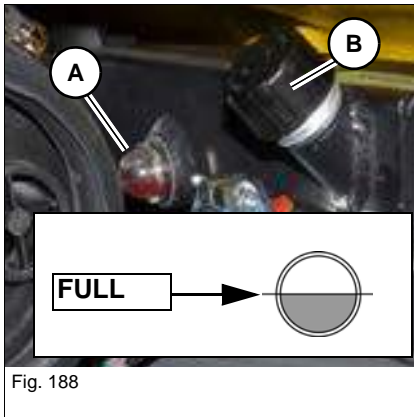

1. Stop and park the machine. Stop the engine – see *“Preparing lubrication” on page 7-8.*
2. Let the engine and the coolant cool down.
3. Open the maintenance flap on the left.
4. Check the coolant level on sight glass **A**.
 - If the coolant level is below the **FULL** mark:
 - Add coolant.
5. Close and lock the maintenance flap on the left.



Information

Check the coolant level once a day before starting the engine. Observe the coolant compound table.

Adding coolant

1. Stop and park the machine. Stop the engine – see *“Preparing lubrication” on page 7-8.*
2. Let the engine and the coolant cool down.
3. Open the maintenance flap on the left.
4. Carefully unscrew filler cap **B** and release the pressure.
5. Open filler cap **B**.
6. Add coolant up to the **FULL** mark.
7. Close filler cap **B**.
8. Start the engine and let it warm up for about 5 – 10 minutes.
9. Stop the engine.
10. Check the coolant level again on the sight glass.
11. If necessary, add coolant and repeat the procedure until the coolant level remains constant.
12. Close and lock the maintenance flap on the left.

Cleaning the radiator

 **WARNING**

Burn hazard due to hot surfaces!

Can cause serious burns or death.

- ▶ Stop the engine and let hot surfaces cool down.
 - ▶ Wear protective equipment.
-

NOTICE

Possible damage to diesel engine and hydraulic system due to dirt on the radiator fins.

- ▶ Check the radiator for dirt and if necessary clean it once a day.
 - ▶ In dusty or dirty work conditions, clean more frequently than indicated in the maintenance plan.
-

NOTICE

Damage to radiator fins during cleaning.

- ▶ Keep a safe distance from the radiator during cleaning.
 - ▶ Use oil-free compressed air (2 bar/29 psi max.) to clean.
-

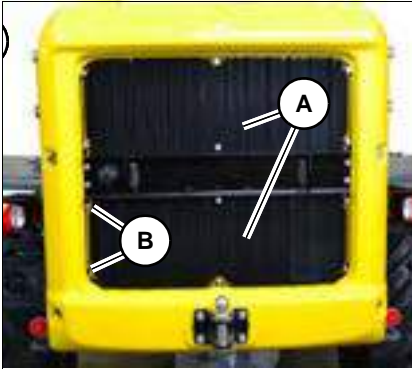

Fig. 189

Water/hydraulic oil radiator, fuel cooler, charge-air cooler

The water/hydraulic oil radiator, the fuel cooler and the charge-air cooler (option) are located behind fan grid **A**.

1. Stop and park the machine. Stop the engine – see *“Preparing lubrication” on page 7-8*.
2. Remove dust and other foreign bodies from the fan grid with compressed air.
3. In case of heavier dirt, remove the 12 screws **B** and fan grids **A**.
4. Carefully clean the radiator with unlubricated compressed air with a max. 2 bar (29 psi).

Install fan grids **A** again and fasten them with 12 screws **B**.

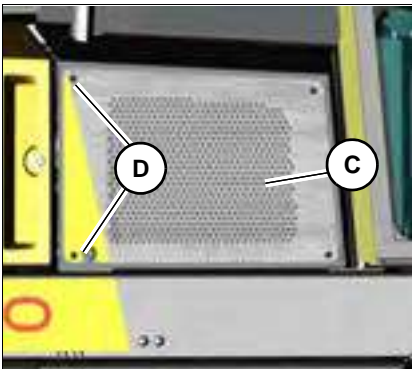

Fig. 190

Condenser (option)

The condenser is located behind cover **C** on the right.

1. Remove 4 screws **D** and cover **C**.

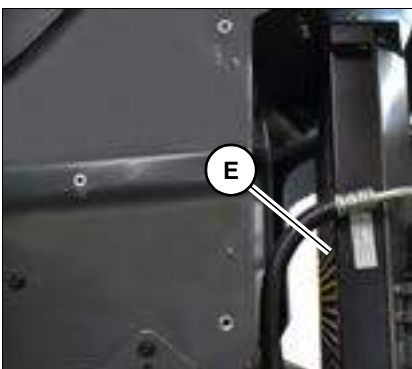

Fig. 191

2. Open the maintenance flap on the right.
3. Blow compressed air from the inside to the outside to remove dust and other foreign bodies from the fins of condenser **E**.
4. Close and lock the maintenance flap on the right.
5. Install cover **C**.

7.10 Air filter

Have maintenance performed only by a Wacker Neuson service center.

Checking the air intake

NOTICE

Possible engine damage due to intake of dirty air.

► Check once a day before putting the machine into operation.



Fig. 192

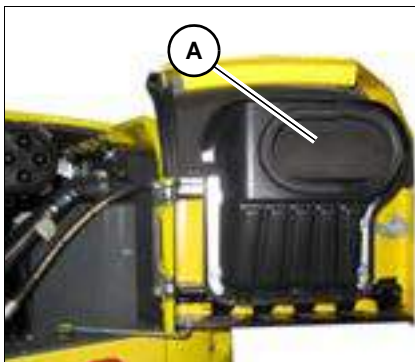

Fig. 193

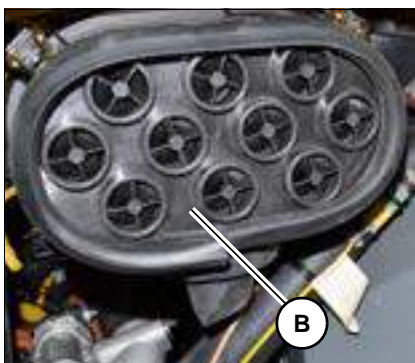

Fig. 194

1. Stop and park the machine. Stop the engine – see *“Preparing lubrication” on page 7-8.*
2. Remove dust and other foreign bodies on the outside of the ventilation grids on the maintenance flap on the left.
3. Open the maintenance flap on the left.

4. Blow unlubricated compressed air from the inside to the outside with a max. 2 bar (29 psi) to remove dust and other foreign bodies from filter **A** on the maintenance flap on the left.
5. Close and lock the maintenance flap on the left.

NOTICE

Even the smallest dirt particles penetrating into the air intake can cause machine damage.

► Have air filter **B** changed only by a Wacker Neuson service center.

7.11 V-belt

Have the V-belt tension checked and the V-belt retensioned only by a Wacker Neuson service center.

7.12 Hydraulic system

Important information on the hydraulic system

 **WARNING****Burn hazard due to hot hydraulic oil!**

Hot hydraulic oil can cause burning to the skin, serious injury or death.

- ▶ Release the pressure in the hydraulic system.
 - ▶ Let the engine cool down.
 - ▶ Wear protective equipment.
-

 **WARNING****Injury hazard due to fluid escaping under pressure!**

Hydraulic oil escaping under pressure can penetrate the skin and cause serious injury or death.

- ▶ Do not operate the machine with leaking or damaged hydraulic system components.
 - ▶ Open the breather filter carefully to slowly release the pressure inside the reservoir.
 - ▶ Wear protective equipment. If oil contacts the eye flush immediately with clean water and seek medical treatment.
 - ▶ Have damaged or leaky threaded fittings, hoses and pressure lines immediately repaired or replaced by a Wacker Neuson service center. Search for hydraulic leaks with a piece of cardboard.
-

NOTICE

Damage due to wrong hydraulic oil.

- ▶ Only use hydraulic oil according to **Fluids and lubricants**.
 - ▶ Have the hydraulic oil only changed by a Wacker Neuson service center.
-

NOTICE

Damage to hydraulic system due to incorrect hydraulic oil level.

- ▶ With a warm engine, the hydraulic oil must be about at the middle of the sight glass.
- ▶ Check the hydraulic oil level once a day.

NOTICE

Possible damage to hydraulic system due to dirty hydraulic oil.

- ▶ Always add hydraulic oil using the filling screen.
- ▶ Cloudy hydraulic oil in the sight glass is a sign of water or air in the hydraulic system. Contact a Wacker Neuson service center.
- ▶ Contact a Wacker Neuson service center if the filter of the hydraulic system is dirty.

Release the pressure in the hydraulic system

Operate the control lever repeatedly to release the pressure in the hydraulic system.

Checking the hydraulic oil level

Fig. 195

1. Stop and park the machine. Stop the engine – see *“Preparing lubrication” on page 7-8.*

2. Lower the skip.

3. Release the pressure in the hydraulic system.

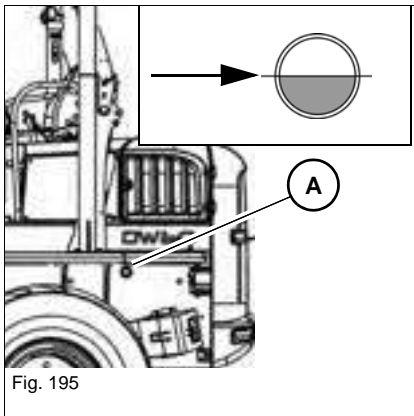
4. Remove the starting key and carry it with you.

5. Sight glass **A** is located at the rear left.

6. Check the oil level on sight glass **A**.

- ▶ If the engine is warm, the oil level must be approximately at the middle of sight glass **A**.

Add hydraulic oil if the oil level is below this mark.

Adding hydraulic oil

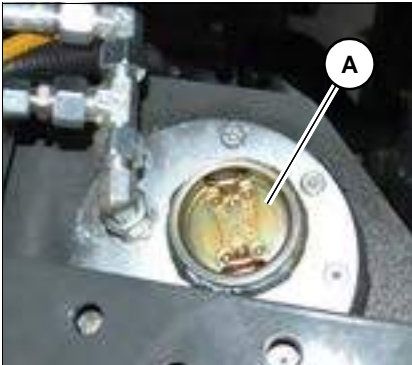

Fig. 196

The filler opening of the hydraulic oil reservoir is located behind the maintenance flap on the left.

1. Stop and park the machine. Stop the engine – see *“Preparing lubrication” on page 7-8.*
2. Release the pressure in the hydraulic system.
3. Open the maintenance flap on the left.
4. Clean the area around the filler opening of the hydraulic oil with a lint-free cloth.
5. Open cover **A** of the filler opening for the hydraulic oil slowly to release the pressure inside the hydraulic oil reservoir.
6. Add hydraulic oil until the oil level is approximately in the middle of the sight glass.
7. Put cover **A** into place and screw it on tightly.
8. Close and lock the maintenance flap on the left.



Environment

Use a suitable container to collect fluids and lubricants as they flow out and dispose of them in an environmentally friendly manner.

Checking the hydraulic system and hoses

Check the hydraulic system and hoses daily for leaks and general condition.

NOTICE

Leaks and damaged pressure lines must immediately be repaired or replaced by a Wacker Neuson service center. This not only increases the operating safety of the machine but also helps to protect the environment.

- ▶ Have damaged or leaky pressure lines immediately repaired or replaced by a Wacker Neuson service center.
- ▶ Have hydraulic hoses replaced every 6 years from the date of manufacture, even if they do not seem to be damaged.

-
- Do not operate the machine with leaking or damaged hydraulic system components.
 - Retighten leaking threaded fittings and hose connections only when the system is not under pressure. Release the pressure before working on pressure lines.
 - Do not weld or solder damaged or leaking pressure lines and threaded fittings, but have them replaced.
 - Wear protective equipment.

In this respect, Wacker Neuson recommends that you observe all the relevant safety regulations for hydraulic lines, as well as the safety regulations regarding accident prevention and occupational health and safety in your country. Also observe DIN 20 066, part 5.

The article number is marked on the clamping section, and the date of manufacture is indicated on the hose of each hose connection.

Have a line immediately replaced if one of the following problems is detected:

- Damaged or leaky hydraulic seals
- Worn or torn shells or uncovered reinforcement branches
- Expanded shells in several positions.
- Entangled or crushed movable parts
- Foreign bodies jammed or stuck in protective layers.

7.13 Electrical system

Important information regarding the electrical system

Maintenance and repair work on the electrical system may only be performed by a Wacker Neuson service center.

- Have malfunctioning components of the electrical system replaced by a Wacker Neuson service center.
- Light bulbs and fuses may be replaced by the operator.

Alternator

- Have malfunctioning charge indicator lights immediately replaced.
-



WARNING

Injury hazard due to malfunctioning batteries!

Batteries give off explosive gases that can cause deflagrations if ignited.

- ▶ Fire, open flames and smoking is prohibited.
 - ▶ Wear protective equipment.
 - ▶ Do not jump start the engine if the battery is malfunctioning or frozen, or if the acid level is too low.
 - ▶ Disconnect the grounding strap of the battery before starting repair work on the electrical system.
 - ▶ Do not place conductive articles on the battery – risk of short circuit.
-

NOTICE

Possible damage to electrical components or engine electronics.

- ▶ When connecting the battery leads, ensure that the poles are not inverted.
 - ▶ Do not place conductive articles on the battery – risk of short circuit.
 - ▶ Do not interrupt voltage-carrying circuits at the battery terminals because of the sparking hazard.
 - ▶ Do not disconnect the battery while the engine is running. Wait at least two minutes between removing the starting key and disconnecting the battery in order to avoid damage to the engine control unit.
 - ▶ After removing the starting key, wait at least two minutes before actuating the battery master switch in order to avoid damage to the engine control unit.
-



Environment

Dispose of old batteries in an environmentally friendly manner.

Fuses and relays

- Blown fuses indicate overloading or short circuits. Have the electrical system checked by a Wacker Neuson service center.
- Only use fuses with the specified amperage.

– see chapter “Fuse box” on page 9-6.

Battery state of charge

Have this checked only by a Wacker Neuson service center.

Charging the battery

Have this performed only by a Wacker Neuson service center.

Replacing the battery

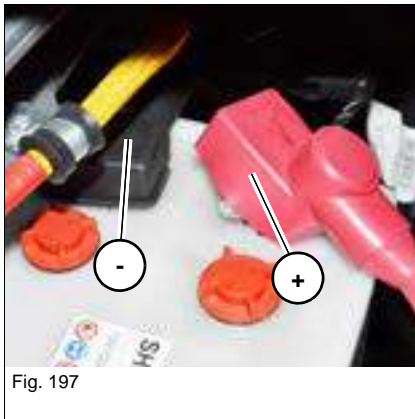

The battery is maintenance-free. However have the battery checked at regular intervals to ensure that the electrolyte level is between the MIN and MAX marks.

Checking the battery requires it to be removed and must be performed by a Wacker Neuson service center.

Follow the specific battery safety instructions.

NOTICE

In order to avoid damage to the engine electronics, do not disconnect the battery while the engine is running.

Battery master switch

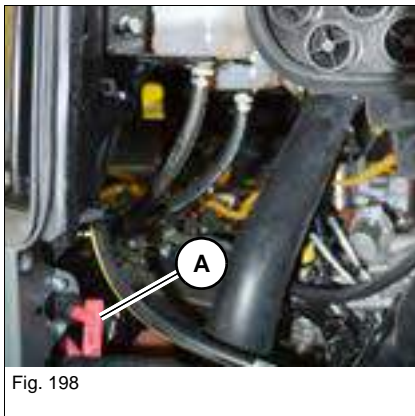

Battery master switch **A** is located behind the maintenance flap on the left. Immediately actuate battery master switch **A** in case of a short circuit. Contact a Wacker Neuson service center.

7.14 Heating, ventilation and air conditioning system

Checking/changing the cabin air filter

Have this performed only by a Wacker Neuson service center.

7.15 Washer system

Only use glass cleaner (with antifreeze if necessary) for refilling.

Checking the fluid level and adding fluid

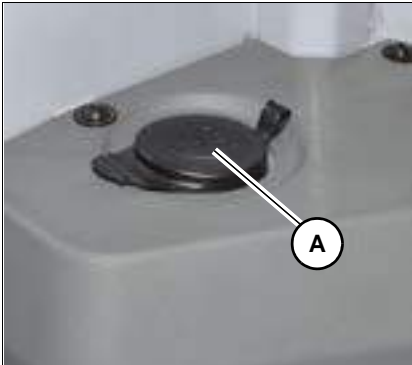

Fig. 199

Reservoir **A** is located on the right in the cabin.

1. Stop and park the machine. Stop the engine – see [“Preparing lubrication” on page 7-8](#).
2. Check the level in reservoir **A** and add a cleaning solution (glass cleaner) if necessary.

7.16 Axles

Have maintenance performed only by a Wacker Neuson service center.

7.17 Braking system

Have maintenance performed only by a Wacker Neuson service center.

Checking the brake-fluid level

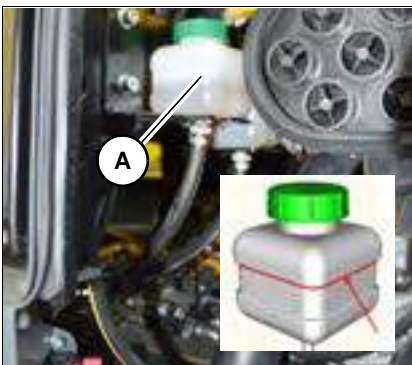

Fig. 200

Brake fluid reservoir **A** (DW90 and DW100 have two reservoirs) is located behind the maintenance flap on the left. The fluid level must reach the mark indicated. Check the fluid level once a day, add fluid if necessary – see [chapter “7.3 Fluids and lubricants” on page 7-10](#).

7.18 Tires



Information

Use only tires and rims released for the machine.

– see chapter “9.5 Tires” on page 9-4

WARNING

Accident hazard due to incorrect maintenance!

Can cause serious injury or death.

- ▶ Have repair work on wheels, tires, etc. performed only by a Wacker Neuson service center.
 - ▶ Use suitable assembly tools, for example covering sleeves for the studs, a jack.
-

Information

Depending on load, work and ground conditions, the extent of wear of the front and rear tires can be different. Therefore interchange the front and rear tires regularly to ensure identical rolling properties.

Information

If a damaged tire has to be replaced, then also replace the other one on the same axle.

Inspection work

Checking the tires at regular intervals increases operational safety and the service life of the tires, and reduces machine downtimes.

For the permissible tire types and pressures – see chapter “9.5 Tires” on page 9-4

Perform the following maintenance once a day:

- Visual check of the tire condition.
- Check the tire pressure.
- Check the tires and rims for damage and wear.
- Check the wheel nuts for tightness and retighten them if necessary.
- Remove foreign bodies from the tire tread.
- Remove dirt, debris, dust, etc. from the tires.

Wheel change



1. Park the machine on firm, level and horizontal ground.
2. Apply the parking brake.
3. Use wheel chocks to prevent the machine from rolling away.
4. Loosen the wheel nuts of the wheel you want to remove.
5. Place a jack with a lift capacity of 5,000 kg (11,023 lbs) under the axle mounting ensuring stability.
6. Raise the machine on the side where you want to change a wheel.
7. Check the machine is standing firmly.
8. Secure the machine with trestles in appropriate places.

i **Information**

Trestles must be positioned so as to avoid machine damage.

9. Loosen and remove the wheel nuts.
10. Remove the wheel.
11. Place the new wheel onto the wheel bolts.
 - ➔ Bear in mind the correct direction of rotation of the tires.
12. Tighten opposite wheel nuts alternately.
13. Remove the trestles.
14. Lower the raised side of the machine.
15. Tighten opposite wheel nuts alternately to 450 Nm (332 ft.lbs).

i **Information**

After changing a wheel, check the wheel nuts for tightness after 10 operating hours. Retighten the wheel nuts if necessary.

7.19 Maintenance of attachments

Not available.

7.20 Maintenance of options

– see chapter “7.2 Maintenance overview” on page 7-2

7.21 Exhaust gas treatment

The machine is equipped with a particulate matter catalyst for cleaning the exhaust gas (only Tier IV).

The soot produced by burning diesel fuel is collected and burned in the particulate matter catalyst at regular intervals. This process is called regeneration.

Regeneration takes about 30 minutes. The more often the automatic regeneration mode is corrected or modified, the longer regeneration takes.

If the dirt in the particulate matter catalyst reaches a critical value, engine power is reduced and machine operation has to be stopped.

Regeneration is only performed if the engine is at operating temperature.

WARNING

Health hazard due to exhaust gases!

Can cause serious health hazards or death.

- ▶ Do not inhale exhaust gases.
- ▶ Use exhaust-gas suction systems suitable for exhaust-gas temperatures of up to 600 °C (1,112 °F).
- ▶ Ensure sufficient ventilation during operation in enclosed premises.

WARNING

Burn hazard at the exhaust system!

During regeneration, the exhaust system develops exhaust-gas temperatures of about 600 °C (1,112 °F), even if the engine is running at idling speed, which can cause serious burns or death.

- ▶ Keep a safe distance from the exhaust system.

WARNING

Fire hazard during regeneration!

Hot exhaust gases in easily flammable environments cause serious injury and death.

- ▶ In environments with easily flammable material, disable the **automatic regeneration** mode.
 - ▶ Do not perform manual regeneration in environments with easily flammable material.
 - ▶ Use only exhaust-gas suction systems suitable for exhaust-gas temperatures of up to 600 °C (1,112 °F).
-

NOTICE

Possibly irreparable damage of the particulate matter catalyst.

- ▶ Perform regeneration as early as possible.
 - ▶ Do not ignore the **highest load** indication.
-

 **Information**

The load is the contamination level of the particulate matter catalyst. Among other things, this level depends on the load on the diesel engine:

- ▶ High engine load = low load.
 - ▶ Low engine load = high load.
-

 **Information**

Wacker Neuson recommends not to influence the automatic regeneration if possible. Should it be necessary to disable or interrupt regeneration, perform it again as soon as possible.



This increases the service life of the particulate matter catalyst and avoids unscheduled stops at the service center, for example with shorter engine-oil replacement intervals.

The particulate matter catalyst is a maintenance part since soot and ash particles cannot be completely removed for technical reasons.

 **Information**



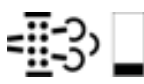
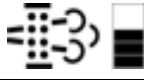
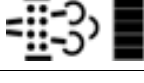

Have the particulate matter catalyst cleaned or replaced by a Wacker Neuson service center every 3000 operating hours.

Indication of load

Symbol ¹	Description	Effect
	Low load	Full engine power Automatic regeneration possible
	Medium load	Full engine power Automatic or manual regeneration is possible
	Highest load	Reduced engine power Only manual regeneration is possible
	Symbol flashes: PCM regeneration required	
	Symbol illuminates: PCM regeneration active	

1. The symbols are displayed from software version 3.3. In earlier software versions status messages (SPN 3701-001/3701-010/3701-011 or 3700-010/SPN 3700-001) appear in the multifunctional display.

Particulate matter catalyst indicator lights

Engine warning	Engine stop	Exhaust-gas temperature	Regeneration required	Regeneration disabled	Description
Yellow	Red	Yellow	Yellow	Yellow	
					
On	On	On	On	On	After switching on the starter, the indicator lights are checked during the first two seconds.
Off	Off	Off	Off	Off	No malfunction.
Off	Off	Off	On	Off	Regeneration is required.
Off	Off	On	On	Off	Active regeneration. Increased exhaust-gas temperatures.
Off	Off	On	Off	Off	Regeneration is completed. Increased exhaust-gas temperature. System is being cooled. The indicator light goes out one minute after the end of regeneration.
Off	Off	Off	Off	On	Regeneration is disabled or interrupted.
Flashes	Off	Off	On	Off	The load has reached the permissible value. Reduced engine power. Regeneration is required.
Flashes	On	Off	On	Off	The load has exceeded the permissible value. Reduced engine power. Travel the machine out of the area with easily-flammable matter. Stop the engine immediately. Contact a Wacker Neuson service center.

Regeneration push button

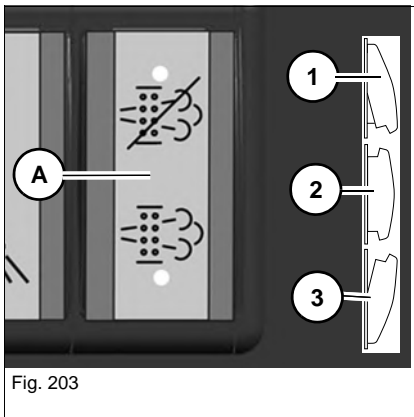

Fig. 203

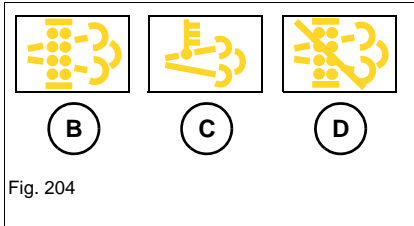

Fig. 204

Push button **A** is located on the right of the steering wheel.

Push button **A** is in the middle position and can be pressed either upward or downward, but does not engage.

The **automatic regeneration** mode is preset if the engine is stopped for at least 30 seconds.

Push button functions

- 1: disable/interrupt/re-enable regeneration
- 2: **automatic regeneration** mode (middle position)
- 3: Release of manual regeneration

Indicator lights

Three indicator lights indicate the regeneration status.

B: Regeneration required.

This indicator light illuminates if the amount of dirt has reached a specific value.

C: Increased exhaust-gas temperature

This indicator light illuminates during regeneration. It goes out once regeneration is over and the system has cooled down.

D: Regeneration disabled/interrupted

This indicator light illuminates if the push button is pressed to position **1**.

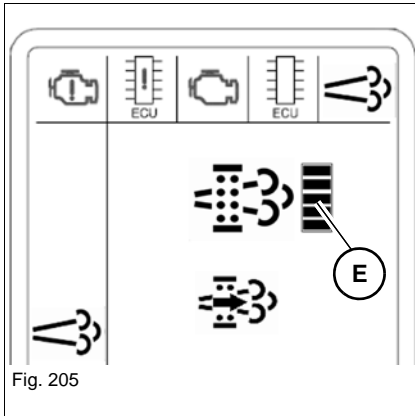

Fig. 205

Indication **E** in the multifunctional display changes depending on the contamination level (from software version 3.2).

Position	Effect	Indication
Lowest load	Automatic regeneration, no functional limitations. Indicator light D must not illuminate – see “Automatic regeneration mode” on page 7-47.	
Moderate load	Automatic or manual regeneration is possible. Indicator light D must not illuminate – see “Automatic regeneration mode” on page 7-47 or – see “Manual regeneration” on page 7-48.	
High load	Automatic regeneration is no longer possible. Engine power is reduced, manual regeneration is required – see “Manual regeneration” on page 7-48	

NOTICE

Possibly irreparable damage of the particulate matter catalyst.

- ▶ Perform regeneration as early as possible.
- ▶ Do not ignore the **high load** indication.

Automatic regeneration mode

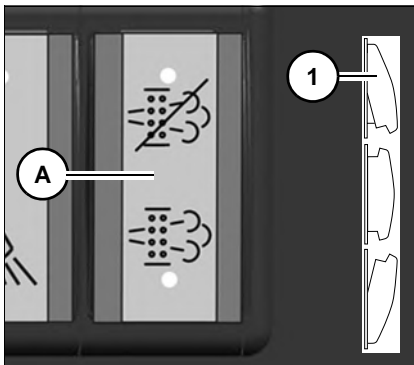

Fig. 206

The **automatic regeneration** mode is preset if the engine is stopped for at least 30 seconds.

NOTICE

Fire hazard at the exhaust system.

- ▶ There must be no easily flammable material in the direct vicinity of the muffler, in particular near the end pipe.
- ▶ In environments with easily flammable material, disable the **automatic regeneration** mode.

If the particulate matter catalyst has reached a certain contamination level, indicator light **B** illuminates and an automatic regeneration is performed soon. Indicator light **C** illuminates in addition during regeneration.



Information

The machine can be operated as usual during regeneration.

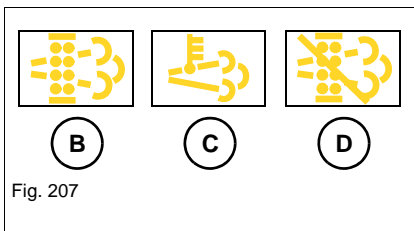

Fig. 207

Disabling/interrupting the **automatic regeneration** mode:

Press and hold push button **A** at least 3 seconds in position **1**.

- Indicator light **D** illuminates.

To re-enable the **automatic regeneration** mode:

Press and hold push button **A** at least 3 seconds in position **1**.

- Indicator light **D** goes out.



Information

Disabling regeneration increases the contamination level in the particulate filter.

Manual regeneration

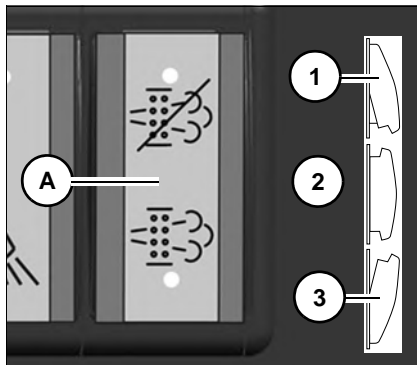

Fig. 208

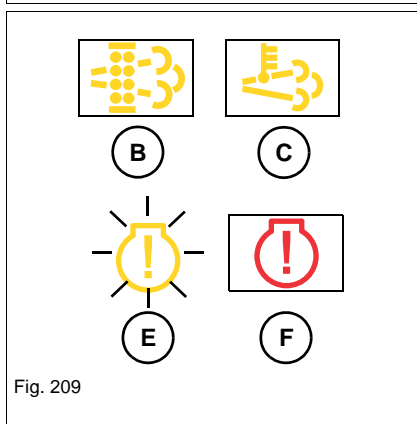

Fig. 209

Starting manual regeneration

Indicator light **B** illuminates and indicator light **E** flashes.

➔ Manual regeneration is possible only in this case and has to be started.

1. Travel the machine out of the danger zone and into a safe area.
2. Apply the parking brake.
3. Press and hold push button **A** at least 10 seconds in position **3**.

➔ Indicator lights **B** and **C** illuminate during regeneration.

Interrupting manual regeneration

Press and hold the **Regeneration** push button at least 3 seconds in position **1**.

NOTICE

Possible damage to engine or particulate filter.

- ▶ Perform a complete regeneration cycle.

NOTICE

Fire hazard at the exhaust system.

- ▶ There must be no easily flammable material in the direct vicinity of the exhaust system, in particular near the end pipe.
- ▶ Do not perform manual regeneration in environments with easily flammable material.



Information

Machine travel or operation is prohibited during manual regeneration.

- ▶ Do not leave the machine during regeneration.

Regeneration not performed – stopping the machine

Engine power is reduced if indicator lights **B** and **F** illuminate and if indicator light **E** flashes.

Stop the engine immediately and contact a Wacker Neuson service center.

7.22 Machine preservation



Machines are partly preserved at the factory (for example in the engine compartment). Operation in an aggressive environment (for example salt deposits) is prohibited.

8 Malfunctions



NOTICE

Contact a Wacker Neuson service center in case of malfunctions or signs that are not listed in the following tables or that persist after maintenance has been performed correctly.





8.1 Engine warning lights



Engine warning	Engine stop	Description
Yellow	Red	
		
On	On	All warning and indicator lights illuminate for a few seconds if the starting key is turned to position 1.
Off	Off	No malfunction.
On	Off	The engine runs correctly, but there is an error in the electronic engine management. Contact a Wacker Neuson service center.
Flashes	Off	The engine runs correctly, but a diagnosis or error code is issued causing a reduction of engine power. Contact a Wacker Neuson service center.
Flashes	On	Engine is about to be shut down, or is already shut down. Stop the engine immediately and contact a Wacker Neuson service center.
Flashes	Flashes	The engine runs but specific engine parameters are outside the permissible range. Stop the engine immediately and contact a Wacker Neuson service center.
On	On	Engine is about to be shut down, or is already shut down. Stop the engine immediately and contact a Wacker Neuson service center.

8.2 Engine and engine oil indicator lights

Engine warning	Engine stop	Oil pressure	Description
Yellow	Red	Red	
			
On	On	On	All warning and indicator lights illuminate for a few seconds if the starting key is turned to position 1. If the engine stop or oil pressure light does not illuminate, stop machine operation immediately and contact a Wacker Neuson service center.
Off	Off	Off	No malfunction.
On	On	On	Low oil pressure (if the oil pressure indicator light illuminates during operation). Check the oil level and add oil if necessary – see chapter “Adding engine oil” on page 7-27 . If the malfunction is still indicated, stop the engine and contact a Wacker Neuson service center.
Off	Off	Flashes	The engine oil and engine oil filter replacements are due within the next 20 operating hours.
On	Off	Flashes	The engine oil has reached the total operation time.
Flashes	On	Flashes	The engine oil has exceeded the total operation time. Contact a Wacker Neuson service center. The engine performance is reduced since the maintenance interval is exceeded.

8.3 Malfunctions (display element/multifunctional display)

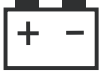
Symbol		Description	See
Display element	Multifunctional display		
Red	--		
		Buzzer sounds. Dirty air filter. Contact a Wacker Neuson service center.	7-32
		The battery is no longer charged. Possible alternator or V-belt malfunction. Note: Increase the engine speed. The electrical system is in working order if the charge indicator light goes out after about one minute. If the malfunction is still indicated, stop the engine immediately and contact a Wacker Neuson service center.	--

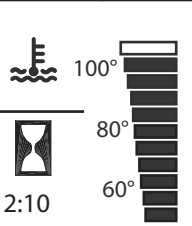
Symbol		Description	See
Display element	Multifunctional display		
Red	--		
		The battery is no longer charged Coolant temperature too high. Alternator or V-belt malfunction. Stop the engine immediately. Contact a Wacker Neuson service center.	--
		Buzzer sounds. Coolant temperature too high. Let the engine run at idling speed without any load. Wait until the temperature drops and the indicator light goes out. Stop the engine. Clean the radiator if necessary, or check the coolant level. If the malfunction is still indicated, stop the engine and contact a Wacker Neuson service center.	7-29 7-30
--	SPN 97	Indication only for machines equipped with Tier IV: water in fuel system. Empty the water separator.	7-23

8.4 General malfunctions

Malfunction	Possible cause	Remedy	See
Engine does not start or is not easy to start	Empty fuel tank	Refueling	7-20
	Malfunctioning or empty battery	Replace the battery	7-15
	Malfunctioning fuse	Check the fuse	9-6
	Electronic feed pump is not running	Contact a Wacker Neuson service center	--
Machine travel cannot be started	Parking brake applied	Release the parking brake	5-4
	No travel direction selected	Select a travel direction	5-3
	Engine speed too low	Press the accelerator pedal	5-3
	Malfunctioning operator presence switch (option)	Contact a Wacker Neuson service center	--
	Temperature of traveling drive is too low	Let the machine run warm	--
Reduced drive output	Technical malfunction	Contact a Wacker Neuson service center	--
	Oil temperature too low	Let the engine run warm	4-35
	Operating temperature too high	Let the engine cool down at idling speed and then contact a Wacker Neuson service center	--
	Maintenance not performed	Perform maintenance	--
Speed ranges cannot be changed	Service brake pressed too lightly	Press the service brake with more force	--
	Machine not at a standstill	Stop the machine to a complete standstill	--
	Malfunctioning fuse	Check the fuse	9-6
	Malfunctioning hydraulic system	Contact a Wacker Neuson service center	--
	Malfunctioning limit switch in gearbox	Contact a Wacker Neuson service center	--
Maximum travel speed is not reached	Eco function enabled	Disable the Eco function	5-11
	Speed range 1 selected	Select speed range 2 (DW90/100 only)	5-11
Engine starts, but does not run smoothly or dies	Air in fuel system	Bleed the fuel system	7-22
Black engine smoke (Tier III) or output loss (Tier IV)	Dirty air filter	Contact a Wacker Neuson service center	--
Blue engine smoke	Oil level too high	Contact a Wacker Neuson service center	--
Machine pulls to the right or left	Damaged steering cylinder	Contact a Wacker Neuson service center	--
	Uneven wear of the tires	Contact a Wacker Neuson service center	--

Malfunction	Possible cause	Remedy	See
None of the hydraulic functions can be operated	Mechanical lock enabled	Release the lock lever	5-10
	Control valve error	Contact a Wacker Neuson service center	--
Electrical components do not work	Malfunctioning fuse	Check the fuse	9-6
Fan does not run	Malfunctioning fuse	Check the fuse	9-6
	Electrical fault	Contact a Wacker Neuson service center	--
Reduced or no cooling capacity	Too much or not enough refrigerant in the system	Contact a Wacker Neuson service center	--
	Malfunctioning V-belt		
	Slack V-belt (Tier III)		
	Dirt on outside of condenser	Clean the condenser	7-30
Reduced heating output or none at all	Temperature controller set to heating	Set temperature controller to ventilation	5-21
	Dirt inside the fan grid	Clean the fan grid	5-21
	Malfunctioning thermostat	Contact a Wacker Neuson service center	--
	Temperature controller set to ventilation	Set temperature controller to heating	5-21
Loss of refrigerant	Loose hose connection	Contact a Wacker Neuson service center	--
	Leak in system		
	Malfunctioning radiator filler cap		
Very loud air conditioning/ventilation	Malfunctioning V-belt	Contact a Wacker Neuson service center	--
	Slack V-belt (Tier III)		
	Damaged air conditioning compressor		
	Damaged fan motor		

Engine error messages



Information

The traveling drive is throttled at low oil temperatures. Warm up the machine to operating temperature.

Observe the following if an error is displayed in the multifunctional display:

Machine travel or operation is prohibited in case of major errors

- Engine performance is reduced.
- The traveling drive is disabled.
- Stop and park the machine.
- Contact a Wacker Neuson service center and have the malfunction rectified.







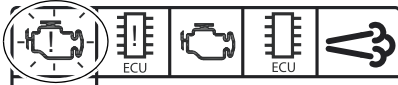

Machine travel and operation is possible in case of minor errors.

- Engine performance is not reduced.
 - The traveling drive is throttled.
 - Contact a Wacker Neuson service center and have the malfunction rectified.
-

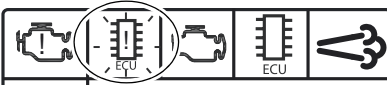

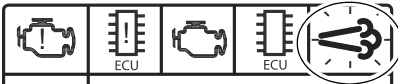
Information

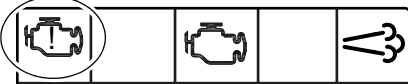
Possible errors are displayed in the multifunctional display for a few seconds when the machine is started.

Symbol	
 <p>SPN XXXXXX SPN XXXXXX SPN XXXXXX SPN XXXXXX SPN XXXXXX</p> 	<p>Engine error Indicates engine errors.</p>
 <p>SPN XXXXXX SPN XXXXXX SPN XXXXXX SPN XXXXXX SPN XXXXXX</p> 	<p>Machine error Indicates machine errors.</p>
 <p>SPN XXXXXX SPN XXXXXX SPN XXXXXX SPN XXXXXX SPN XXXXXX</p> 	<p>Particulate matter catalyst data Indicates particulate matter catalyst data.</p>
 <p>SPN XXXXXX</p>  	<p>No error If there is no error, the marked symbol appears in the service tool "Engine error/machine status/particulate matter catalyst data". The corresponding symbol flashes and is displayed at the bottom in addition.</p>

Notes:

9 Technical data

9.1 Model designations and trade names

Machine model	Trade name
D18-01	DW60
D18-02	DW90
D18-03	DW100

9.2 Engine

Engine	DW60 62.5 kW (83.8 hp)	DW60, DW90, DW100 55 kW (73.8 hp)	DW60, DW90, DW100 86 kW (115.3 hp)
Manufacturer	Perkins		
Type	1104D-44T	854F-E34TTF	854E-E34TAWF
Design	Water-cooled 4-cylinder diesel engine		
Intake system	Turbo-charging		Turbo-charging, charge air cooling
Fuel injection system	Direct injection		
Engine management	Mechanical	Electronic	
Displacement	4399 cm ³ (268 in ³)	3387 cm ³ (207 in ³)	
Nominal bore and stroke	105 x 127 mm (4.1 x 5 in)	99 x 110 mm (3.9 x 4.3 in)	
Output	62.5 kW at 2400 rpm (83.8 hp at 2400 rpm)	55 kW at 2500 rpm (73.8 hp at 2500 rpm)	86 kW at 2500 rpm (115.3 hp at 2500 rpm)
Max. torque	354 Nm at 1400 rpm (261 ft.lbs at 1400 rpm)	291 Nm at 1600 rpm (215 ft.lbs at 1600 rpm)	420 Nm at 1600 rpm (310 ft.lbs at 1600 rpm)
Max. engine speed with-out load	2200 +/- 25 rpm		
Idling speed	800 +/- 50 rpm		
Starting aid	Glow plugs (preheating time 15 seconds)	Sheathed-element heater plugs ¹	
Exhaust-gas treatment	--	Particulate matter catalyst	
Exhaust values according to	EU NRMM 97/68/EC Level 3A US EPA 40 CFR Part 89 Tier III UN/ECE-R120	EU NRMM 97/68/EC Level 3B US EPA 40 CFR Part 89 Tier IV final UN/ECE-R120	EU NRMM 97/68/EC Level 3B US EPA 40 CFR Part 89 Tier IV interim UN/ECE-R120

1. Preheating time controlled by engine control unit.

9.3 Traveling drive/axles

Traveling drive		DW60 62.5 kW (83.8 hp)/ DW60, DW90, DW100 55 kW (73.8 hp)	DW60, DW90, DW100 86 kW (115.3 hp)
Design		Infinitely variable axial piston pump with electric control	
Flow rate		152 l/min (40 gal/min)	171 l/min (45 gal/min)
Max. operating pressure		450 bar (6,527 psi)	
Starting speed		1300 rpm	
Oscillation	Center	11.1°	
	Right	9.2°	
	Left	10.1°	
Boost pump		DW60, DW90, DW100	
Design		Trochoid pump	
Flow rate		17 cm ³ /rev (1.04 in ³ /rev)	
Min. charging/boost pressure		20 bar (290 psi)	
Max. charging/boost pressure		35 bar (508 psi)	
Hydraulic motor		DW60	DW90, DW100
Design		Axial piston motor with bent axis	
Max. capacity		160 cm ³ /rev (9.76 in ³ /rev)	110 cm ³ /rev (6.71 in ³ /rev)
Flushed with flush valve		20 l/min at 16 bar (5.3 gal/min at 232 psi)	15 l/min at 16 bar (4.0 gal/min at 232 psi)
Transmission ratio	Speed range 1	2.37	3.29
	Speed range 2		1.62

9.4 Brakes

Service brake		DW60	DW90, DW100
Design		Single-circuit brake	Dual-circuit brake
		Wet multidisk brake on front and rear axles	
Location		Front axle center housing	Center housing of front and rear axles
Effect	Front wheels	Direct	Direct
	Rear wheels	Via cardan shaft	
Parking brake		DW60, DW90, DW100	
Design		Hydraulic parking brake	
Location		Front axle center housing	
Effect		Via cardan shaft on all 4 wheels, hydromechanical actuation	

9.5 Tires

Tire type/size		DW60		DW90, DW100	
Tire size		400/55R22.5	405/70-20 (16/70-20)		500/60-22.5
Model		Lawn	MPT01	MPT03	500
Tire pressure	Front axle	6.0 bar (87 psi)	3.5 bar (51 psi)		4.5 bar (65 psi)
	Rear axle	2.5 bar (36 psi)			3.0 bar (44 psi)
Load-bearing capacity		146J	149 B	145 G	158 A8

9.6 Steering system

		DW60	DW90	DW100
Design		Hydrostatic		
Steering mode		Chassis articulation steering		
Power supply		Via gear pump		
Steering angle		29°		28.3°
Outside turning radius	Front skip	6149 mm (20'-2")	6803 mm (22'-4")	6803 mm (22'-4")
	Swivel skip	5998 mm (19'-8")	6546 mm (21'-6")	--

9.7 Operating hydraulics

Operating hydraulics	DW60 62.5 kW (83.8 hp)/ DW60, DW90, DW100 55 kW (73.8 hp)	DW60 86 kW (115.3 hp)/ DW90, DW100
Hydraulic pump	69.2 cm ³ (4.22 in ³)	78.1 cm ³ (4.77 in ³)
Gear pump	31 cm ³ (1.89 in ³)	
Flow rate at 2200 rpm	68 l/min (18 gal/min)	
Max. operating pressure (travel operation)	450 bar (6,527 psi)	
Hydraulic oil radiator	Yes	
Hydraulic reservoir capacity (middle of sight glass)	55 l (14.53 gal)	
Hydraulic reservoir capacity	78.5 l (20.7 gal)	
Regulation method	Mech. controlled valve	
Max. operating pressure (operating hydraulics)	240 bar +/- 5 bar (3,481 psi +/- 73 psi)	
Filter	Pressure filter	
Braking system	DW60, DW90, DW100	
Service brake	Mechanically actuated brake, no hydraulic support	
Parking brake	Hydromechanically actuated brake	

Steering system	DW60, DW90, DW100
Flow rate at 2200 rpm	68 l/min (18 gal/min)
Max. operating pressure	180 bar +15 bar/-5 bar (2,611 psi +218 psi/-73 psi)
Secondary pressure protection	235 bar +15 bar/-5 bar (3,408 psi +218 psi/-73 psi)

Maximum speed

	DW60 62.5 kW (83.8 hp)	DW60 55 kW (73.8 hp)/ DW60 86 kW (115.3 hp)	DW60 86 kW (115.3 hp) (option)	DW90/100 55 kW (73.8 hp)	DW90/100 option 86 kW (115.3 hp)	DW90/100 86 kW (115.3 hp)
Speed range 1 ¹	25 kph (16 mph)		28 kph (17 mph)	14.5 kph (9 mph)		
Speed range 1 with Eco ON ¹	20 kph (12 mph)			12 kph (7.5 mph)		
Speed range 2 ¹	--		25 kph (16 mph) with load 28 kph (17 mph) without load	30 kph (19 mph)	25 kph (16 mph)	
Speed range 2 with Eco ON ¹	--		25 kph (16 mph)		20 kph (12 mph)	
Reverse speed range 1	20 kph (12 mph)			14.5 kph (9 mph)		
Reverse speed range 1 with Eco ON				12 kph (7.5 mph)		
Reverse speed range 2	--		20 kph (12 mph)			

1. Follow the national and regional legal regulations regarding maximum speed.

9.8 Electrical system

Electrical components	DW60 62.5 kW (83.8 hp)	DW60 55 kW (73.8 hp)	DW60 86 kW (115.3 hp)	DW90/ 100 55 kW (73.8 hp)	DW90/ 100 86 kW (115.3 hp)
Alternator	12 V/100 A	12 V/120 A			
Starter	12 V/3.2 kW				
Battery ¹	12 V/100 Ah				
Battery ²	12 V/120 Ah				
12 V socket	15 A max.				

1. According to DIN EN 50342, DIN IEC 60095-2
2. Higher-capacity battery as an option

Fuse box

Fuse box **A** is located at the front right of the chassis.

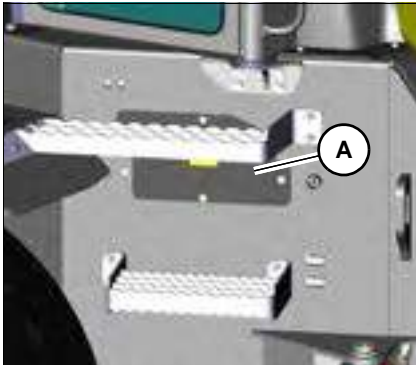

Fig. 210

Main fuses **B** are located on the right.

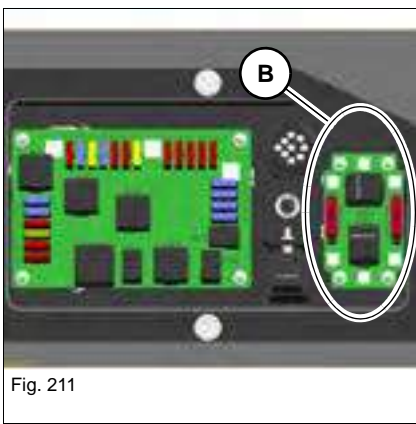

Fig. 211

Schematic fuse box assignment for all models

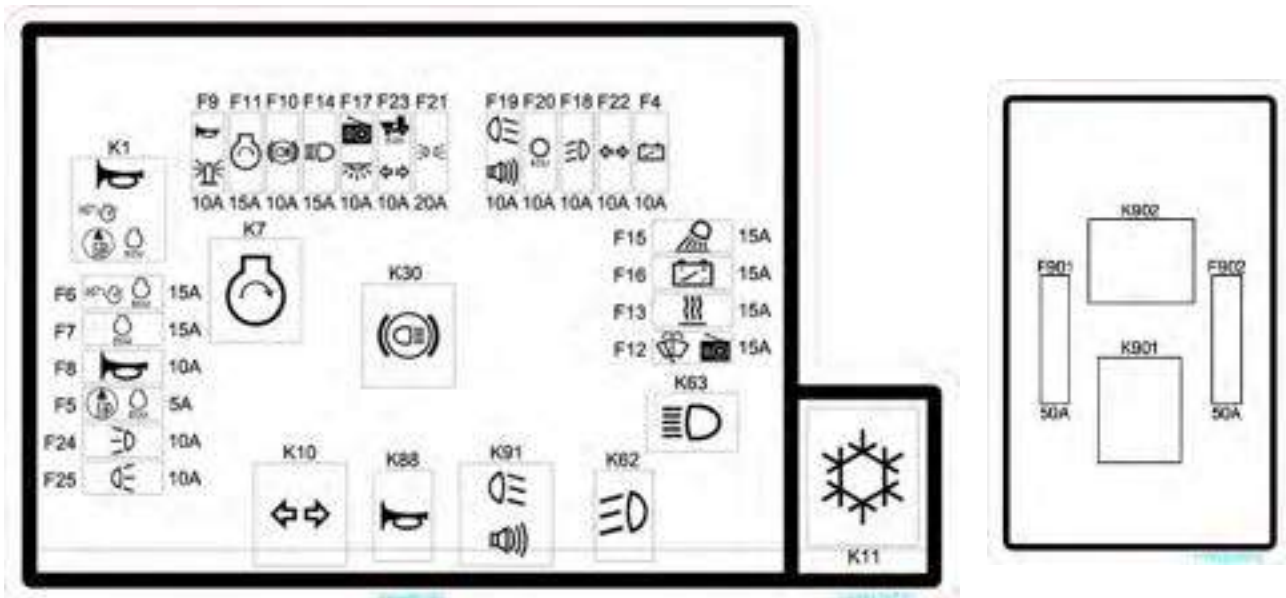

Fig. 212

Fuses/ relays	Rated cur- rent	Protected circuits Tier III	Protected circuits Tier IV
F901	50A	Fuel pump	Engine control unit
		Starter, machine control unit 12 V 30 and 12 V 15, lights, multifunctional display, radio, wiper ² , air conditioning, clearance lights ¹ , hazard warning system ¹	
F902	50A	---	Diagnosis connector
		Starter plus 12 V 15, preheating, cutoff solenoid, drive control unit, reversing light ¹ , reversing signal ¹ , low beam ¹ , high beam ¹ , turn indicators ¹ , air conditioning	
F4	10A	Cutoff solenoid	Diagnosis connector, water separator, PCM regeneration switch
		switched starter plus 12 V 15_1, fuse relay K1	
F5	5A	Fuel pump	Engine control unit
F6	15A	Additional start quantity	
F7	15A	---	
F8	10A	Horn ¹	
F9	10A	Horn ¹ , rotating beacon ¹	
F10	10A	Brake lights ¹	
F11	15A	Starter	
F12	15A	Wiper ² , radio 12 V 15 ²	
F13	15A	Heating ²	
F14	15A	High beam ¹	
F15	15A	Working light	
F16	15A	Diagnosis connector, camera display ³ , machine control unit 12 V 15, control lever push buttons, operator presence switch	
F17	10A	Radio 12 V 30 ² , interior light ²	
F18	15A	Low beam ¹	
F19	10A	Reversing lights, reversing signal ¹	
F20	10A	Drive control unit	
F21	20A	Clearance lights ¹	
F22	10A	Turn indicator 12 V 15 ¹	
F23	10A	Machine control unit 12 V 30, hazard warning system ¹	
F24	10A	Clearance lights (left) ¹	
F25	10A	Clearance lights (right) ¹	
K901	Relay	Switched starter plus 12 V 15_1	
K902	Relay	Preheating	Air conditioning ²

Fuses/ relays	Rated cur- rent	Protected circuits Tier III	Protected circuits Tier IV
K1	Relay	Fuel pump, additional start quantity, horn ¹	Engine control unit, horn ¹
K7	Relay	Starter	
K10	Relay	Turn indicators ¹	
K11	Relay	Air conditioning ²	---
K30	Relay	Brake lights ¹	
K62	Relay	Low beam ¹	
K63	Relay	High beam ¹	
K88	Relay	Horn ¹	
K91	Relay	Reversing lights ¹ , reversing signal ¹	

1. Austrian road traffic regulations StVZO package option.

2. Cabin or protective window option.

3. The red camera-display cable is fitted with an additional fuse.

Bulbs

	DW 60/90/100
Working lights/roof lights	H3 12 V/55 W
Interior light	Festoon lamp 12 V/5 W
Rotating beacon	H1 12 V/55 W
Front turn indicator and clearance light	P21W 12 V/5 W
Clearance light	P21W
Parking light and low beam	H4 12 V/55 W
Rear lights	R10W
Reversing light	P21W
Brake lights	P21W
Rear turn indicators	R10W

9.9 Tightening torques

General tightening torques

Property class	8.8	10.9	12.9	8.8	10.9
Screw dimensions	Screws according to DIN 912, DIN 931, DIN 933, etc.			Screws according to DIN 7984	
	Nm (ft.lbs.)	Nm (ft.lbs.)	Nm (ft.lbs.)	Nm (ft.lbs.)	Nm (ft.lbs.)
M5	5.5 (4)	8 (6)	10 (7)	5 (4)	7 (5)
M6	10 (7)	14 (10)	17 (13)	8.5 (6)	12 (9)
M8	25 (18)	35 (26)	42 (31)	20 (15)	30 (22)
M10	45 (33)	65 (48)	80 (59)	40 (30)	59 (44)
M12	87 (64)	110 (81)	147 (108)	69 (51)	100 (74)
M14	135 (100)	180 (133)	230 (170)	110 (81)	160 (118)
M16	210 (155)	275 (203)	350 (258)	170 (125)	250 (184)
M18	280 (207)	410 (302)	480 (354)	245 (181)	345 (254)
M20	410 (302)	570 (420)	690 (509)	340 (251)	490 (361)
M22	550 (406)	780 (575)	930 (686)	460 (339)	660 (487)
M24	710 (524)	1000 (738)	1190 (878)	590 (435)	840 (620)
M27	1040 (767)	1480 (1092)	1770 (1305)	870 (642)	1250 (922)
M30	1420 (1047)	2010 (1482)	2400 (1770)	1200 (885)	1700 (1254)

Tightening torques/fine-pitch thread					
Property class	8.8	10.9	12.9	8.8	10.9
Screw dimensions	Screws according to DIN 912, DIN 931, DIN 933, etc.			Screws according to DIN 7984	
	Nm (ft.lbs.)	Nm (ft.lbs.)	Nm (ft.lbs.)	Nm (ft.lbs.)	Nm (ft.lbs.)
M8X1.0	25 (18)	37 (28)	43 (32)	22 (16)	32 (24)
M10X1.0	50 (37)	75 (55)	88 (65)	43 (32)	65 (48)
M10X1.25	49 (36)	71 (52)	83 (61)	42 (31)	62 (46)
M12X1.25	87 (64)	130 (96)	150 (111)	75 (55)	110 (81)
M12X1.5	83 (61)	125 (92)	145 (107)	72 (53)	105 (77)
M14X1.5	135 (100)	200 (148)	235 (173)	120 (89)	175 (129)
M16X1.5	210 (155)	310 (229)	360 (266)	180 (133)	265 (195)
M18X1.5	315 (232)	450 (332)	530 (391)	270 (199)	385 (284)
M20X1.5	440 (325)	630 (465)	730 (538)	375 (277)	530 (391)
M22X1.5	590 (435)	840 (620)	980 (723)	500 (369)	710 (524)
M24X2.0	740 (546)	1070 (789)	1250 (922)	630 (465)	900 (664)
M27X2.0	1100 (811)	1550 (1143)	1800 (1328)	920 (679)	1300 (959)
M30X2.0	1500 (1106)	2150 (1586)	2500 (1844)	1300 (959)	1850 (1364)

9.10 Coolant

Compound table

Outside temperature ¹	Distilled water	Coolant ²
up to -37 °C (-34.6 °F)	50 % by volume	50 % by volume

1. Use the 1:1 concentration for warm outside temperatures, too, to ensure protection against corrosion, cavitation and deposits.
2. Do not mix the coolant with other coolants.

9.11 Noise emissions

	DW60 55 kW (73.8 hp)	DW60 55 kW (73.8 hp)	DW60 86 kW (115.3 hp)	DW90/100 86 kW (115.3 hp)
Measured sound power level L _{WA} ¹	101 dB(A)	102 dB(A)	101 dB(A)	103 dB(A)
Guaranteed sound power level L _{WA} ¹	101 dB(A)	102 dB(A)	103 dB(A)	103 dB(A)
Uncertainty factor K _{pA} ²	1.0	0.8	0.8	0.9
Operator-perceived sound pressure level L _{pA} (without cabin) ³	81 dB(A)	81 dB(A)	82 dB(A)	81 dB(A)
Operator-perceived sound pressure level L _{pA} (with cabin) ³	81 dB(A)	81 dB(A)	82 dB(A)	81 dB(A)

1. According to ISO 6395 (EC Directives 2000/14/EC and 2005/88/EC)
2. According to EN ISO 4871 (EC Directives 2000/14/EC and 2005/88/EC)
3. According to ISO 6394 (EC Directives 84/532/EEC, 89/514/EEC, 95/27/EEC)



Information

Measurements performed on asphalted surface.

9.12 Vibration

Vibration	
Effective acceleration value for the upper extremities of the body (hand-arm vibration)	< Trigger value < 2.5 m/s ²
Effective acceleration value for the body (whole-body vibration)	< 0.5 m/s ²

Vibration values indicated in m/s².

Directive 2002/44/EC of European Parliament and Council on minimum health and safety requirements regarding exposure of workers to risks arising from physical agents (vibration).

Indications on hand-arm vibration

Hand-arm vibration is less than 2.5 m/s² during correct machine operation.

Indications on whole-body vibration

Whole-body vibration is less than 0.5 m/s² during correct machine operation.

Uncertainty of measurement K has been taken into account for the specified values.

The degree of vibration is influenced by various parameters.

Some of them are listed below:

- Operator: training, behavior, working method and strain.
- Job site: organization, preparation, surroundings, weather conditions and material.
- Machine: version, seat quality, quality of suspension system, attachments and condition of attachments.

Precise indications on the vibration degrees cannot be made for the machine.

Determination of vibration level for the three vibration axes.

- Under typical operating conditions, use the average vibration values measured.
- In order to obtain the estimated vibration value for an experienced operator on level ground, subtract the factors from the average vibration value.
- In case of an aggressive working method or difficult terrain, add the environmental factors to the average vibration level in order to obtain the estimated vibration level.

Note:

For further vibration indications, refer to the indications in ISO/TR 25398 Mechanical Vibrations – Directive on Estimation of whole-body vibration during operation of earth moving machines. This publication uses measuring values of international institutes, organizations and manufacturers. It contains information on whole-body vibration for operators in earth moving machines. For more information on the vibration values of the machine, refer to Directive 2002/44/EC of European Parliament and Council on minimum health and safety requirements regarding exposure of workers to risks arising from physical agents (vibration).

It explains the values for vertical vibration under heavy operating conditions.

Directives on reduction of vibration values in earth moving machines:

- Perform correct adjustments and maintenance on the machine.
- Avoid jerky movements during machine operation.
- Keep slopes in a perfect condition.

Whole-body vibration can be reduced with the following guidelines:

- Use a machine and equipment of correct type and size.
- Follow the manufacturer's recommendations for maintenance:
 - Tire pressure
 - Brake and steering systems
 - Control elements, hydraulic system and linkage
- Keep the job site in good condition:
 - Remove large rocks or obstacles.
 - Fill up ditches and holes.
 - Provide a machine and enough time to keep the job site in good condition.
- Use an operator seat according to the ISO 7096 requirements. Keep the operator seat in good condition and adjust it correctly:
 - Adjust the operator seat and suspension to the operator's weight and size.
 - Check and maintain the seat adjustment and suspension.
- Perform the following activities smoothly without any jerks.
 - Steering
 - Braking
 - Acceleration
 - Shifting gears
- Move attachments without any jerks.
- Adapt your speed and the itinerary to minimize vibration:
 - Travel around obstacles and uneven ground.
 - Reduce your speed during machine travel across rough terrain.
- Reduce vibration to a minimum during long work cycles or during machine operation over long distances:
 - Use a machine with a suspension system (for example on the operator seat).
 - Enable the hydraulic oscillation damping if the machine is equipped with tracks.
 - If the machine is not equipped with hydraulic oscillation damping, reduce your speed to avoid bumps and jolts.
 - Load the machine on a truck or trailer to move between job sites.
- Other risk factors can affect travel comfort negatively. The following measures can improve travel comfort:
 - Adjust the operator seat and the control elements to a relaxed body posture.
 - Adjust the rearview mirrors to ensure optimal visibility so you can adopt an upright seating position.
 - Provide breaks to avoid sitting for long periods.
 - Do not jump off the cabin.
 - Picking up and raising loads repeatedly must be limited to a minimum.

Reference:

The vibration values and calculations are based on the indications made in ISO/TR 25398 Mechanical Vibrations – Guidelines for assessment of exposure to whole-body vibration during operation of earth moving machines.

The harmonized data comply with measurements made by international institutes, organizations and manufacturers. This publication offers information on the calculation of whole-body vibrations for operators of earth moving machines. This method is based on vibration measurements under real operating conditions for all machines. Read the original guidelines. This chapter summarizes part of the legal regulations. However, its aim is not to replace the original references. Other parts of this document are based on information of the United Kingdom Health and Safety Executive.

For more information on vibration, refer to Directive 2002/44/EC of European Parliament and Council on minimum health and safety requirements regarding exposure of workers to risks arising from physical agents (vibration).

Your Wacker Neuson dealer provides information on other machine functions reducing vibration and on safe operation.

9.13 Weight

Machine weights

Front skip ROPS	DW60 kg/lbs	DW90 kg/lbs	DW100 kg/lbs
Transport weight ¹	4532 (9,991)	5232 (11,534)	5277 (11,634)
Operating weight ²	4614 (10,172)	5314 (11,715)	5359 (11,815)
Front skip cabin	DW60 kg/lbs	DW90 kg/lbs	DW100 kg/lbs
Transport weight ¹	4732(10,432)	5432 (11,976)	5477 (12,075)
Operating weight ²	4814 (10,613)	5514 (12,156)	5559 (12,255)
Swivel skip ROPS	DW60 kg/lbs	DW90 kg/lbs	DW100 kg/lbs
Transport weight ¹	4919 (10,845)	5664 (12,487)	--
Operating weight ²	5001 (11,025)	5746 (12,668)	--
Swivel skip cabin	DW60 kg/lbs	DW90 kg/lbs	DW100 kg/lbs
Transport weight ¹	5119 (11,285)	5864 (12,928)	--
Operating weight ²	5201 (11,466)	5946 (13,109)	--

1. Transport weight: machine + 10 % fuel capacity.

2. Operating weight: machine + full fuel tank + skip + operator (75 kg/165 lbs).



Information

The weight specified here corresponds to the maximum configuration. The actual machine weight depends on the selected options and can be read off the type label.

Weight indications can vary by +/- 2 %.

Ground clearance

	DW60/LRC DW60/DW60 P	DW90/100 option
Ground clearance	369 mm (14.53 in)	406 mm (15.98 in)

9.14 Payload

Front skip	DW60	DW90	DW 100
Liquid capacity	1900 l (502 gal)	2400 l (634 gal)	2400 l (634 gal)
Skip capacity (struck)	2650 l (700 gal)	3750 l (991 gal)	4100 l (1083 gal)
Skip capacity (heaped)	3500 l (924 gal)	4550 l (1202 gal)	4750 l (1255 gal)
Swivel skip	DW60	DW90	DW60 3 m
Liquid capacity	1660 l (439 gal)	2060 l (544 gal)	1580 l (417 gal)
Skip capacity (struck)	2350 l (621 gal)	3300 l (872 gal)	2250 l (594 gal)
Skip capacity (heaped)	3200 l (845 gal)	4400 l (1162 gal)	3050 l (845 gal)
	DW60	DW90	DW100
Payload	6000 kg (13,228 lb)	9000 kg (19,842 lb)	10000 kg (22,046 lb)

NOTICE

Possible damage to property due to tipping over of machine. Do not exceed the weights indicated in the table.

Maneuvering coupling (optional)

		DW60/90/100
Drawbar load		200 kg (441 lb)
Traction force ¹	Trailer with overrun brake	3500 kg (7,716 lb)
	Unbraked trailer	2000 kg (4,409 lb)

1. The skip must be filled with a weight of 25 % of its possible payload.

NOTICE

The total tractor weight must not exceed the maximum permissible weight of the tractor.

		Values	DW60 standard mm (in)	DW90 mm (in)	DW100 mm (in)
A1	Height including rotating beacon	Rollbar	3350 (10'-12")	3405 (11'-2")	3595 (11'-10")
		Cabin	3215 (10'-7")	3270 (10'-9")	3460 (11'-4")
A2	Height without rotating beacon	Rollbar	3110 (10'-2")	3165 (10'-5")	3355 (11'-0")
		Cabin	2998 ((9'-10")	3055 ((10'-0")	3245 (10'-8")
A3	Height with lowered rollbar/ without cabin		2300 (91)	2355 (93)	2545 (8'-4")
A4	Height of lowered rollbar		2185 (86)	2240 (88)	2430 (96)
B1	Length without maneuvering coupling		4475 (14'-8")	4660 (15'-3")	
B2	Length with maneuvering coupling		4575 (15'-0")	4760 (15'-7")	
B3	Length with lowered rollbar		4945 (16'-3")	5550 (18'-3")	5130 (16'-10")
C1	Machine width		2250 (89)	2465 (97)	
C2	Skip width		2330 (92)	2495 (98)	2490 (98)
C3	Rollbar width/ cabin including outside mirrors	Rollbar	1520 (60)	1520 (60)	
		Cabin	1585 (62)	1585 (62)	
D	Track		1810 (71)	1920 (76)	
E	Wheelbase		2485 (98)	2700 (8'-10")	
F	Ground clearance		369 (15)	406 (16)	
G1	Tilt-out reach		610 (24)	555 (22)	
G2	Tail-end lateral projection		1190 (47)		
H1	Height of dump edge of skip (skip not tilted out)		1680 (661)	1745 (69)	
H2	Height of upper edge of skip (skip not tilted out)		2020 (80)	2250 (89)	2300 (91)
H3	Height of dump edge of skip (skip tilted out)		460(18)	495 (20)	
H4	Height of upper edge of skip (skip tilted out)		2490 (98)	2755 (9'-0")	
K1	Tilt angle		43°	47°	

Swivel skip with rollbar (overview)

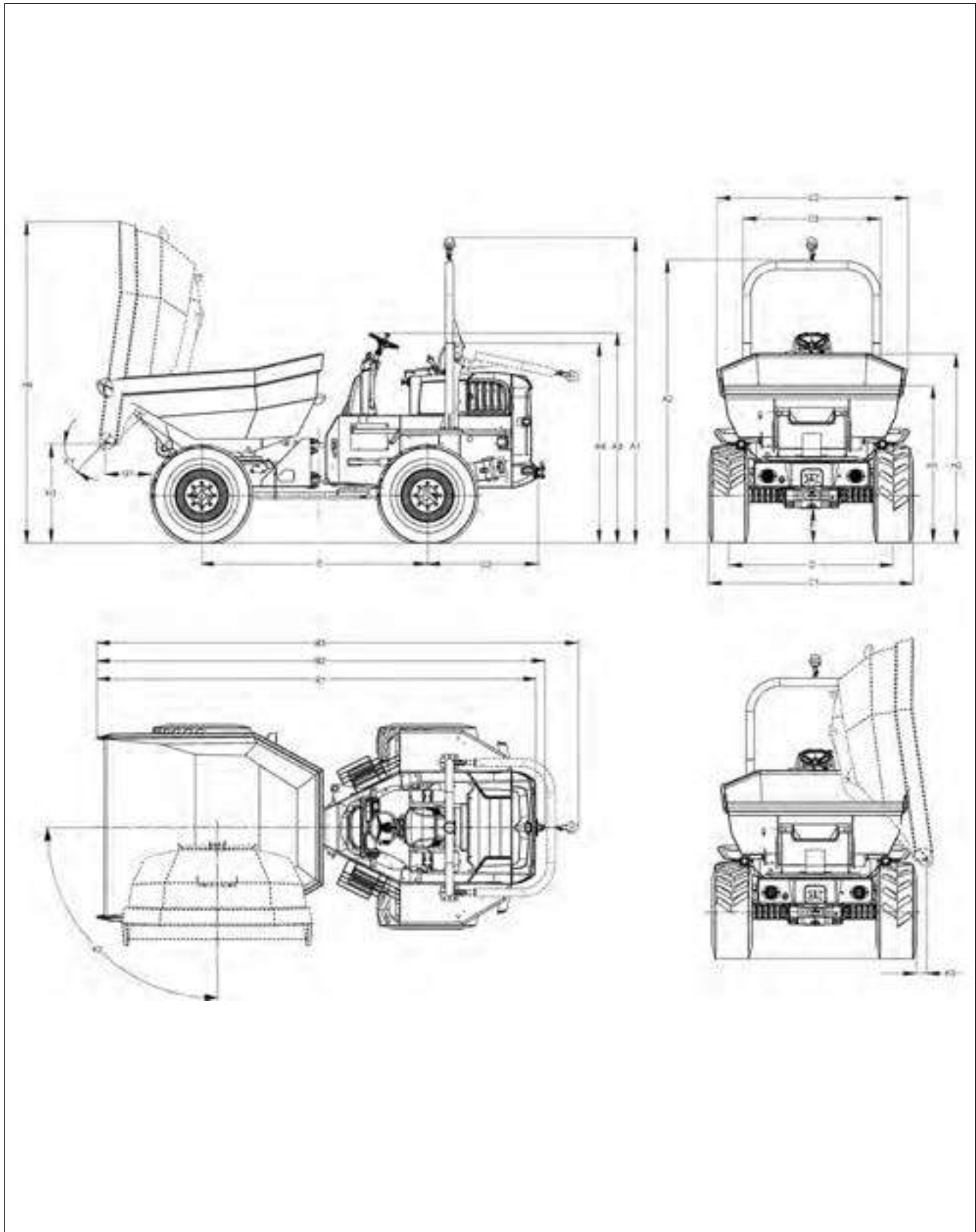

	Values	DW60 standard mm (in)	DW60 3 m skip ¹ mm (in)	DW90 mm (in)
A1	Height including rotating beacon	3350 (10'-12")		3595 (11'-10")
A2	Height without rotating beacon	3110 (10'-2")		3355 (10'-10")
A3	Height with lowered rollbar	2300 (91)		2545 (8'-4")
A4	Height of lowered rollbar	2185 (86)		2430 (96)
B1	Length without maneuvering coupling	4835 (15'-10")	4670 (15'-4")	5085 (16'-8")
B2	Length with maneuvering coupling	4935 (16'-2")	4770 (15'-8")	5185 (17'-0")
B3	Length with lowered rollbar	5300 (17'-5")	5135 (16'-10")	5550 (18'-3")
C1	Machine width	2250 (86)		2465 (97)
C2	Skip width	2090 (82)		2275 (90)
C3	Rollbar width	1520 (60)		
D	Track	1810 (71)		1920 (76)
E	Wheelbase	2485 (98)		2700 (8'-10")
F	Ground clearance	369 (15)		406 (16)
G1	Tilt-out reach	505 (20)	490 (19)	480 (19)
G2	Tail-end lateral projection	1190 (47)		
H1	Height of dump edge of skip (skip not tilted out)	1725 (68)	1730 (68)	1805 (71)
H2	Height of upper edge of skip (skip not tilted out)	2075 (82)		2305 (91)
H3	Height of dump edge of skip (skip tilted out)	1080 (43)	1175 (463)	1170 (46)
H4	Height of upper edge of skip (skip tilted out)	3525 (11'-7")		3865 (12'-8")
K1	Tilt angle	48°		40°
K2	Angle of rotation	90°		
K3	Lateral tilt-out reach	115 (5)	100 (4)	190 (7)

1. Legislation in some countries requires a specific distance between the center of the steering wheel and the front edge of the machine. This distance is maintained with the optional 3 m skip.

	Values	DW60 mm (in)	DW60 3 m skip ¹ mm (in)	DW90 mm (in)
A1	Height including rotating beacon	3215 (10'-7")		3460 (11'-4")
A2	Height without rotating beacon	2998 (9'-10")		3245 (10'-8")
A3	Height without cabin	2300 (91)		2545 (8'-4")
B1	Length without maneuvering coupling	4835 (15'-10")	4670 (15'-4")	5085 (16'-2")
B2	Length with maneuvering coupling	4935 (16'-2")	4770 (15'-8")	5185 (17'-0")
C1	Machine width	2250 (88.58)		2465 (97)
C2	Skip width	2090 (82.28)		2275 (90)
C3	Width including outside mirrors	1585 (62)		
D	Track	1810 (71)		1920 (76)
E	Wheelbase	2485 (98)		2700 (8'-10")
F	Ground clearance	369 (15)		406 (16)
G1	Tilt-out reach	505 (20)	490 (19)	480 (19)
G2	Tail-end lateral projection	1190 (47)		
H1	Height of dump edge of skip (skip not tilted out)	1725 (68)	1730 (68)	1805 (71)
H2	Height of upper edge of skip (skip not tilted out)	2075 (82)		2305 (91)
H3	Height of dump edge of skip (skip tilted out)	1080 (43)	1175 (46)	1170 (46)
H4	Height of upper edge of skip (skip tilted out)	3525 (11'-7")		3865 (12'-8")
K1	Tilt angle	48°		40°
K2	Angle of rotation	90°		
K3	Lateral tilt-out reach	115 (5)	100 (4)	190 (7)

1. Legislation in some countries requires a specific distance between the center of the steering wheel and the front edge of the machine. This distance is maintained with the optional 3 m skip.

Index

A		I	
Abbreviations	1-3	Information before putting into operation	4-29
Adding coolant	7-29	Information on this Operator's Manual	1-1
Air filter		L	
Checking the air intake	7-32	Labels	
B		Information labels	3-12
Battery	7-38	Warning labels	3-8
C		Lateral angle of inclination	5-14
Cabin number	3-7	Letting the engine warm up	4-35, 4-36
Camera	4-9	Loading the machine	6-5
Capacities	7-10	Low-load operation	4-40
Check lists		Lubrication	7-8
Operation	4-32	M	
Parking the machine	4-32	Machine inspections	3-4
Starting	4-31	Machine travel on slopes	5-12
Checking the coolant level	7-29	Maintenance flaps	7-14
Circuit breaker	7-38	Maneuvering coupling	9-15
Control elements	4-17	Maneuvering operation	5-31
Conversion table	1-6	Model designations and trade names	3-3
Coolant		Multifunctional display	
Adding coolant	7-29	Brightness	5-7
Checking the coolant level	7-29	Contrast	5-8
Crane-lifting	2-12, 6-7	Setting the time or date	5-8
D		O	
Danger zone	5-24	Operating temperature range	5-11
Declaration of conformity	EG-1	P	
Definitions		Parking the machine on slopes	5-15
Right/left/front/rear	1-4	Particulate matter catalyst	7-42
Designated use	3-4	Preheating	4-35
Diesel particulate filter	7-42	Preparations for starting the engine	4-34
Indication of load	7-44	Preparing lubrication	7-8
Indicator lights	7-44	Putting into operation for the first time and running-in period	4-33
Regeneration (automatic)	7-47	R	
Regeneration (manual)	7-48	Release the pressure in the hydraulic system	7-34
Driving license	3-4	Requirements for the operating personnel	4-30
E		Reversing signal	5-20
Emergency stop of power supply	7-38	Rollbar	4-13
Equipment	3-4	S	
Explanation of symbols	1-2	Seat adjustment	4-4
F		Seat belt	4-6
Fire extinguisher	4-10	Skip grid	4-16
Fluids and lubricants	7-10	Skip operation	5-22
Foreword	1-1	Starter	4-35
Functional checks		Starting aid	4-37
Brake test	5-5	Starting the engine	4-35
G		Stopping the engine	4-40
Ground clearance	9-14		

T

Tarp (option) 5-1

Technical data

- Brakes 9-3
- Bulbs 9-8
- Coolant compound table 9-10
- Electrical system 9-5
- Engine 9-1
- Front skip dimensions 9-16
- Fuses/relays 9-6
- Ground clearance/ground pressure 9-14
- Machine weights 9-14
- Maximum speed 9-5
- Noise emissions 9-10
- Operating hydraulics 9-4
- Swivel skip with cabin (dimensions) 9-20
- Swivel skip with rollbar (dimensions) 9-18
- Tightening torques 9-9
- Traveling drive/axles 9-2

Tires 9-4

Towing

- Towing the machine 6-4

Towing the machine 6-1

V

Visual range of camera 4-9

W

- Wading depth 5-28
- Warranty and liability 1-7
- Wheel change 7-41
- Wiper 5-20

Wacker Neuson Linz GmbH keep abreast of the latest technical developments and constantly improve their products. For this reason, we may from time to time need to make changes to figures and descriptions in this documentation which do not reflect products that have already been delivered and that will not be implemented on these machines.

Technical data, dimensions and weights are only given as an indication. Responsibility for errors or omissions not accepted.

No reproduction or translation of this publication, in whole or part, without the written consent of Wacker Neuson Linz GmbH.

All rights under the provision of the Copyright Act are reserved.

Wacker Neuson Linz GmbH

Flughafenstr. 7

A-4063 Hörsching

Austria

Important: For spare parts information, please see your Wacker Neuson Dealer, or visit the Wacker Neuson website at <http://www.wackerneuson.com/>.

Wichtig! Informationen über Ersatzteile erhalten Sie von Ihrem Wacker Neuson Händler oder besuchen Sie die Wacker Neuson Website unter <http://www.wackerneuson.com/>.

Important : Pour des informations sur les pièces détachées, merci de consulter votre distributeur Wacker Neuson, ou de visiter le site Internet de Wacker Neuson sur <http://www.wackerneuson.com/>.

Importante : Para saber más sobre las piezas de repuesto, póngase en contacto con su distribuidor de Wacker Neuson o acceda al sitio web de Wacker Neuson en <http://www.wackerneuson.com/>.

Importante : Per informazioni sui pezzi di ricambio, contattare il rivenditore Wacker Neuson o visitare il sito di Wacker Neuson all'indirizzo www.wackerneuson.com.

Viktigt : För information om reservdelar, kontakta din Wacker Neuson-leverantör eller besök Wacker Neusons webbplats på <http://www.wackerneuson.com/>.

Tärkeää : Pyydä varaosatietoja Wacker Neusonin jälleenmyyjältä tai vieraile Wacker Neusonin web-sivustolla osoitteessa <http://www.wackerneuson.com/>

Viktig : For informasjon om reservedeler, vennligst kontakt din Wacker Neuson-forhandler, eller besøk Wacker Neusons nettside på <http://www.wackerneuson.com/>.

Viktigt : Hvis du ønsker opplysninger om reservedele, bedes du kontakte din Wacker Neuson forhandler eller besøk Wacker Neuson websiden på <http://www.wackerneuson.com/>.

Belangrijk! Neem contact op met uw Wacker Neuson dealer of bezoek de website van Wacker Neuson op <http://www.wackerneuson.com/> voor meer informatie over reserveonderdelen.

Importante : Para obter informações sobre as peças sobresselentes, consulte o seu fornecedor da Wacker Neuson ou acesse ao site Web da Wacker Neuson em http://www.wackerneuson.com

Ważne : W celu uzyskania informacji na temat części zamiennych skontaktuj się z przedstawicielem firmy Wacker Neuson lub skorzystaj z witryny internetowej <http://www.wackerneuson.com/>.

Důležitě upozornění! Pro informace o náhradních dílech, prosím, kontaktujte svého Wacker Neuson dealera, nebo navštivte webové stránky <http://www.wackerneuson.com/>.

FONTOS: A pótalkatrészekre vonatkozó információkért kérjük, forduljon Wacker Neuson kereskedőjéhez vagy látogasson el a Wacker Neuson weboldalára a következő címen: <http://www.wackerneuson.com/>.

Важно! Для ознакомления с информацией о запасных частях, пожалуйста, обратитесь к местному торговому представителю компании Wacker Neuson или посетите веб-сайт <http://www.wackerneuson.com/>.

Σημαντικό : Για πληροφορίες σχετικά με τα ανταλλακτικά, μιλήστε με τον αντιπρόσωπό σας της Wacker Neuson, ή επισκεφθείτε τον ιστότοπο <http://www.wackerneuson.com/>.

Važno : Za rezervne dijelove obratite se svom Wacker Neuson prodavaču ili posjetite mrežne stranice tvrtke Wacker Neuson: <http://www.wackerneuson.com/>.

Önemli : Yedek parça bilgileri için Wacker Neuson Bayinize bakın veya Wacker Neuson web sitesini ziyaret edin. <http://www.wackerneuson.com/>

重要 交換部品の情報については、ワッカーノイゾンディーラーにお問い合わせ頂くか、ワッカーノイゾンウェブサイト <http://www.wackerneuson.com/> をご覧ください。

重要 有关备件信息，请咨询您的威克诺森经销商或访问威克诺森网站：
<http://www.wackerneuson.com/>。

Important : Pentru informații referitoare la piesele de schimb, vă rugăm să vă adresați distribuitorului Wacker Neuson sau să vizitați site-ul web Wacker Neuson la adresa <http://www.wackerneuson.com/>.

Важно : За информация относно резервни части, моля, обърнете се към местния дилър на Wacker Neuson или посетете уебсайта на Wacker Neuson на адрес <http://www.wackerneuson.com/>.

Wacker Neuson Produktion GmbH & Co. KG, Preußenstraße 41, D-80809 München,
Tel.: +49-(0)89-3 54 02-0 Fax: +49 - (0)89-3 54 02-390

Wacker Neuson Production Americas LLC, N92W15000 Anthony Ave., Menomonee Falls, WI. 53051
Tel.: (262) 255-0500 Fax: (262) 255-0550 Tel.: (800) 770-0957

Wacker Neuson Limited - Room 1701-03 & 1717-20, 17/F. Tower 1, Grand Century Place, 193 Prince Edward Road West, Mongkok, Kowloon, Hongkong. Tel: (852) 3605 5360, Fax: (852) 2758 0032