

Model

400

Three Way Valve

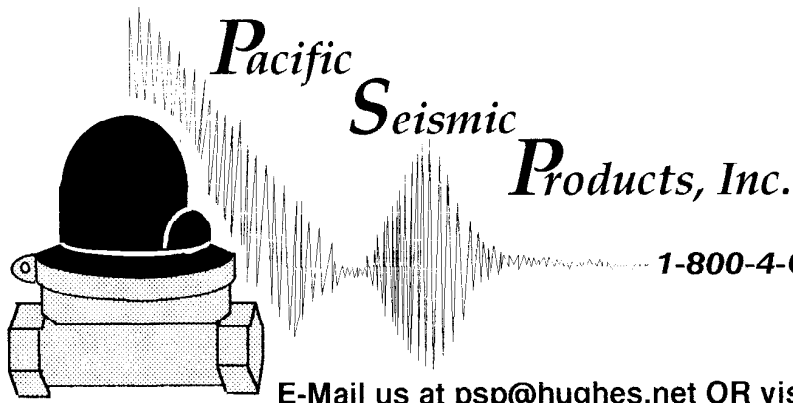

233 East Avenue H-8
Lancaster, CA 93535-1821
(661) 942-4499 • FAX (661) 942-0999

1-800-4-GAS-OFF

E-Mail us at psp@hughes.net OR visit our web site at www.psp4gasoff.com

The Koso/California Seismic Valves

Koso/California Seismic Valves are earthquake-sensitive gas shut-off valves. They are intended to close in the event of an earthquake to prevent gas flow into a structure where earthquake damage may have occurred. The valve reduces the potential for fire or explosion due to the release of natural gas into a structure where gas lines, gas fixtures, or gas appliances may have lost their integrity and may, therefore, allow an uncontrolled flow of gas following a major earthquake.

The valves do not use any source of internal or external electrical power. They are designed to remain closed until manually reset. The valves are intended to be mounted in the gas line upstream or downstream of the gas-line pressure regulator and gas meter outside of the structure. These valves do not replace the manual upstream shut-off valve provided in the gas service line located upstream of the gas meter.

The valve consists of a swing check valve arrangement with an acceleration-sensitive triggering mechanism. The trip mechanism consists of a steel ball resting on a tapered cup-shaped support. The horizontal motion

of an earthquake causes the ball to move from the center of the support. This allows the ball's mass to act upon the movable pipe of the trip mechanism, activating the valve, and initiating closure. Springs assist the valve-flapper to close and gas pressure assists in holding the valve disc in the closed position. The trip mechanism is factory set and sealed. A sight glass is provided so that the *Open* or *Closed* indicator can be seen, and the trip mechanism status of the valve can be easily determined.

The valve can be manually reset to the *Open* position by turning an exposed end of the reset shaft with the appropriate tool, depending on the model.

Installation instructions are provided with each valve.

Koso/Pacific Seismic Products, Inc. (PSP) has been manufacturing the **Koso/California Seismic Valve** since 1978. Serving residential, commercial, and industrial uses, thousands of the Koso/PSP automatic shut-off valves have been installed in California over the last two decades. Our complete line of valves has an outstanding and well-established record of reliability and durability.

Model numbers: 300, 301, 302, 303, 310, 311, 312, 313, 314, 315, 316, 314F, 315F, 316F, and 317F													
		Sizes Available										Ambient Temperature	
		NPT						Flanged					
		3/4"	1"	1 1/4"	1 1/2"	2"	3"	4"	2"	3"	4"	6"	
Maximum Pressures of Available Sizes	0.5 psi	✓	✓	✓	✓								UL: -40° to 150°F CA DSA: -10° to 150°F
	7 psi			✓	✓								
	20 psi	✓	✓	✓	✓	✓	✓	✓	✓	✓	✓		Fluid Natural gas LP gas
	60 psi	✓	✓	✓	✓	✓	✓	✓	✓	✓	✓		

Koso/PSP's California Seismic Valves are UL Listed in the USA and Canada; Certified by the California Division of the State Architect; Approved by the City of Los Angeles; and Warranted free of manufacturing defects for 30 years.

PSP

PACIFIC SEISMIC PRODUCTS, INC.

233 East Avenue H-8 • Lancaster, CA 93535-1821 • Ph: 805/942-4499 • Fax: 805/942-0999

MODEL 400 **EARTHQUAKE ACTUATED 3-WAY VALVE**

***** INSTRUCTIONS *****

OPENING and RESETTING

When you receive the valve it will be in the “Closed” position.

When the valve is closed the word “Closed” will be visible through the window in the visual valve position indicator located on the top of the valve just above the clamp band.

TO OPEN AND RESET THE VALVE

With a suitable wrench, apply light force to rotate reset shaft counter clockwise until the word “Open” is visible through the window.

Release pressure on the wrench, and the reset shaft will return to its original position. The word “Open” remains visible through the window.

The valve is now open, and the acceleration trigger mechanism is set to respond to seismic disturbances.

CAUTION: Resetting the valve requires only light force. Excess force can damage the valve.

PSP

PACIFIC SEISMIC PRODUCTS, INC.

233 East Avenue H-8 • Lancaster, CA 93535 • 805/942-4499 • Fax 805/942-0999

MODEL 400 EARTHQUAKE ACTUATED 3-WAY VALVE

WARNING: FOR USE WITH DRY AIR or NITROGEN ONLY (NO PLANT AIR)

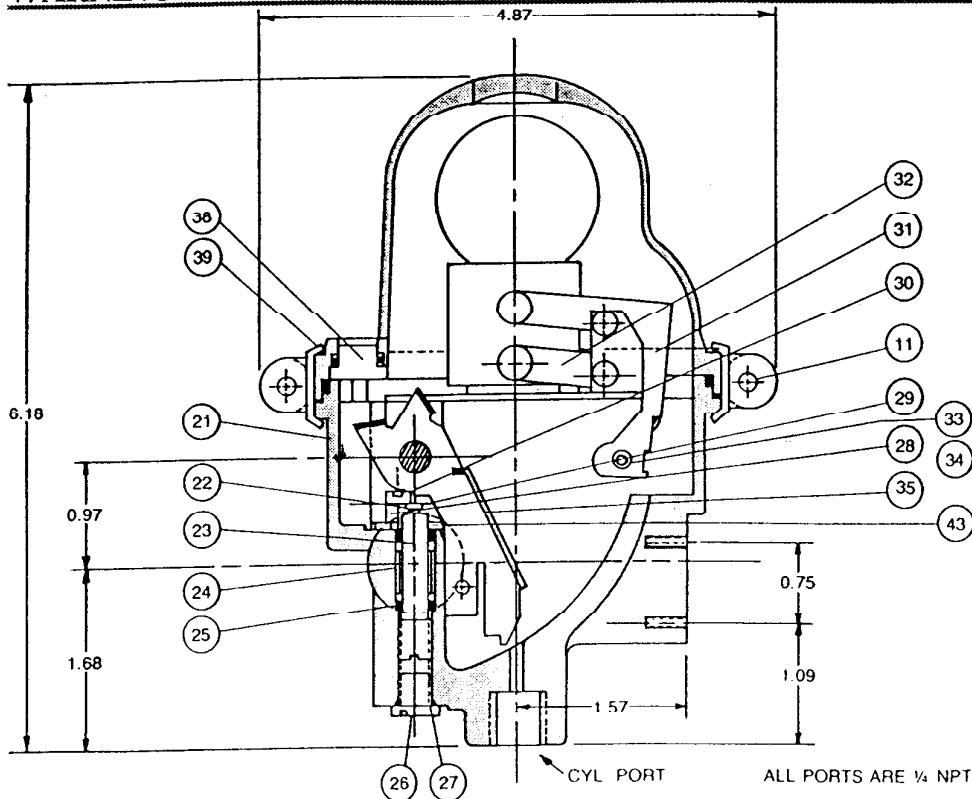

SPECIFICATIONS

EXTERNAL LEAKAGE: None with 100 psi internal pressure for 60 seconds, normally closed and normally open ports plugged. **INTERNAL LEAKAGE:** Tripped condition 80 psi internal pressure. No leakage through normally open port in 30 seconds. **NORMALLY CLOSED PORT LEAKAGE:** Latched condition 80 psi to normally closed port. No leakage through normally closed port in 60 seconds.

SEISMIC RESPONSE

With valve latched, 80 psi to normally closed port, apply 2.5 c.p.s. Sine Wave Displacement. Valve shall trip between 0.2G and 0.3G (opening normally closed port valve, and closing the normally open port). The test set-up shall prevent internal pressure from exceeding 80 psi.

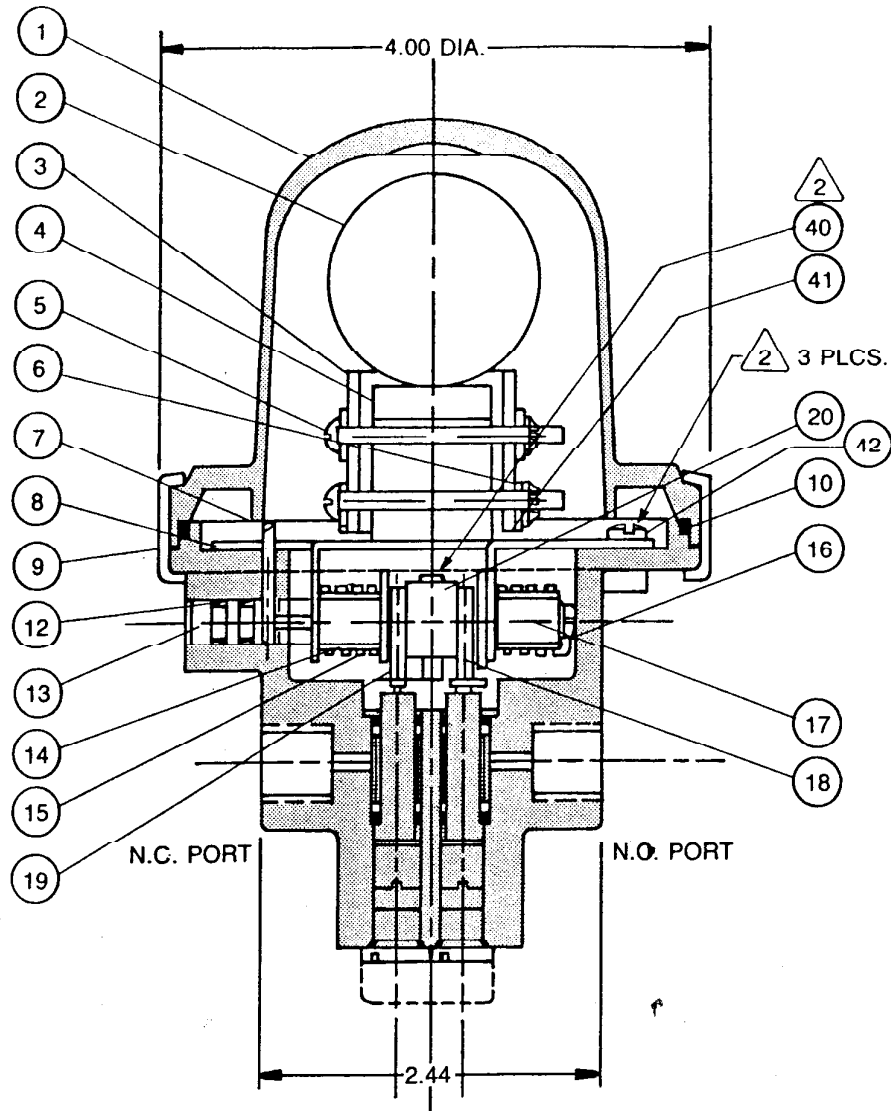

MATERIAL REFERENCE ONLY	NO.	PART NO.	NAME	QTY.
AL. AL.	1	DV77-101	COVER	1
STEEL	2	B-1½	BALL	1
AL. AL.	3	DV77-114	PIPE	1
AL. AL.	4	DV77-106	SUPPORT	1
ST. ST'L	5	DV77-118	PIN A	4
ST. ST'L	6	CSTW-3	PUSH NUT	4
STEEL	7	DV77-120	CLIP	1
STEEL	8	DV77-109	BASE	1
STEEL	9	DV77-110B	RING CLAMP	2
BUNA "N"	10	S90	"O" RING	1
ST. ST'L	11	RM4-4	RIVET	2
BUNA "N"	12	MY-5	MINI-Y PACKING	2
ST. ST'L	13	DV77-117A-2	RESET SHAFT	1
STEEL	14	SP8-11	SPACER	2
STEEL	15	DV77-121-1	SPRING A	1
STEEL	16	DV77-122	SPRING B	1
ST. ST'L	17	DV77-116	SWING SHAFT	1
GRAPHITE/NYLON	18	SAS 1001	CAM "A"	1
GRAPHITE/NYLON	19	SAS 1000	CAM "B"	1
AL. AL.	20	DV77-105-Z	CAM	1
AL. AL.	21	SPS0995-1	BODY	1
ASSY.	22	AM FLPW#406	VALVE CORE	2

MATERIAL REFERENCE ONLY	NO.	PART NO.	NAME	QTY.
BRASS	23	SAS1101	INSERT (RWK)	2
BRASS	24	SAS1100	SPACER "A"	2
BUNA "N"	25	PRA 6227-5	"O" RING	4
AL. AL.	26	SAS1102	CAP	2
BUNA "N"	27	PRA 6227-6	"O" RING	2
AL. AL.	28	SAS 1104	SPACER	1
BE. CU	29	SAS0999	SPRING "E"	1
STEEL	30	SAS1103	SCREW	1
STEEL	31	DV-77-107	TRIP ARM	1
STEEL	32	DV-77-111	GUIDE ARM	2
ST. ST'L	33	DV-77-119	PIN B	1
ST. ST'L	34	SPN1.5	PUSH NUT	2
STEEL	35	DV-77-108A	SWING ARM	1
BRASS	36	C83-60	CHAIN	2
STEEL	37	DV-77-113-(2)	LEVEL ARM	1
GLASS	38	DV-77-104G	WINDOW	1
BUNA "N"	39	DV-77-124	"O" RING	1
STEEL	40	WM4-5-U	SET SCREW	1
ST. ST'L	41	DV-77-115	PLATE SPRING	1
STEEL	42	CNS-10-U	SCREW	3
STEEL	43	SAS1102	PLATE	1

• Final User/Owner: Keep these instructions for future use; DO NOT DISCARD •

The Koso/California Seismic Valves

Models #300, 301, 302, 303, 310, 311, 312, 313, 314, 314F, 315, 315F, 316, 316F, 317F
Earthquake-actuated Automatic Gas Shut Off Valves

Pacific Seismic Products, Inc. • 233 East Avenue H-8 • Lancaster, CA, 93535 USA Installation & Maintenance Instructions

Installation and maintenance must be done to the requirements of the local building code or other governing agency requirements and must be performed by personnel having the qualifications required by law to install and service natural gas lines and equipment.

The valve must be installed in the gas line **before the line enters the protected structure**. Generally this is on the customer's side of the meter, or upstream of the meter when approved by the utility.

Install valve in upright position with the gas flow in the direction of the arrow on the valve body. The plumb chain in the level indicator on the side of the valve must be centered in the hole through which it passes in the bracket.

Warning - If the valve is installed so the gas flow is in the direction OPPOSITE FROM THE ARROW on the valve body, the valve WILL NOT OPERATE PROPERLY.

Valve Installation

The Valve installation must be rigidly mounted to the earth, to the foundation, or near the foundation of the protected structure, so that seismic movements will be transmitted to the acceleration trigger mechanism located within the valve assembly.

The valve should only be installed in gas lines which Maximum Pressure never exceeds the Maximum Pressure stamped on the valve's nameplate band. During installation when making pipe connections to the valve body the turning effort on the valve body pipe threads SHALL NOT EXCEED the figures on this chart:

Nominal Pipe Size	Turning Effort/lbch-Pounds
3/4" NPT	580
1" NPT	750
1-1/4" NPT	875
1-1/2" NPT	940
2" NPT	1190
3" NPT	1310
4" NPT	1500

After the installation is complete the gas service should be restored according to **Opening & Resetting of the Valve** (see next column).

Verification of Valve Operation

Local regulating and governing agencies may require periodic verification demonstration to prove the valve's readiness to shut off the gas flow during a seismic disturbance. Procedures specified by the local governing agency must be followed.

WARNING! Read and UNDERSTAND the following sections completely before attempting to reset valve.

Opening & Resetting of the Valve - Models 300, 301, 302, 303, 310, 311

When the valve is closed a Red Bar will be visible through the window in the visual valve position indicator located on the top of the valve just above the clamp band. To open the valve first verify that the main gas shutoff valve is closed, then gently rotate the Reset Shaft (located on the side of the valve) in the direction indicated by the "to open" arrow, until the Green Bar is visible through the window. Release the turning effort. If reset has occurred the Reset Shaft will return to its original position, and the Green Bar will remain visible through the window. The valve is now open, and the acceleration trigger mechanism set to respond to a seismic disturbance.

Opening & Resetting of the Valve- Models 312, 313, 314, 314F, 315, 315F, 316, 316F, and 317F

When the valve is closed a Red Bar will be visible through the window in the visual valve position indicator located on the top of the valve just above the clamp band. To open the valve, first verify that the main gas shutoff valve is closed, then gently rotate the Reset Shaft in the direction indicated by the "to open" arrow, which opens the pressure release poppet in the main valve disc. Hold in this position until pressure equalizes across the main valve disc, then with very little turning effort, continue rotating the Reset Shaft until a Green Bar is visible through the window. Release the turning effort. If reset has occurred the "Reset Shaft" will return to its original position and the Green Bar will remain visible through the window. The valve is now open, and the acceleration trigger mechanism set to respond to a seismic disturbance.

Warning - If the "Reset Shaft" does not return to its original position, or the valve remains closed and will not reset, the gas service must be shut off, and the valve replaced before service can be restored. If the valve will not reset, call for technical service at 800/442-7633.

After an Earthquake

The acceleration trigger mechanism within the valve has been factory tested to verify that the finished valve complies with federal, state, and local code requirements and/or specifications. Gas plumbing damage may have occurred during an earthquake or aftershock. If a gas leak exists, gas service should be turned off at the main shut off valve. Do not turn gas on again. You will be safer if you let authorized personnel restore service.

Note: On Models 314, 315, and 316 a Reset Shaft is located on both sides of the valve.