

# GR-SENS Adjustable Current Limiting Switch

15A Version

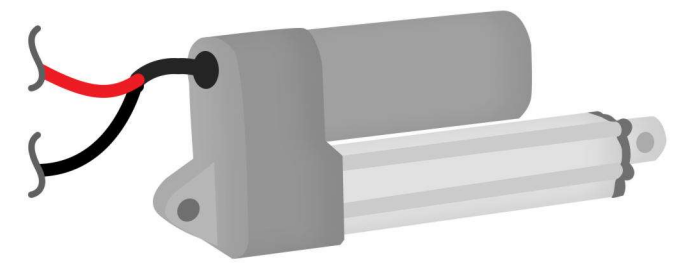

Version March 2020

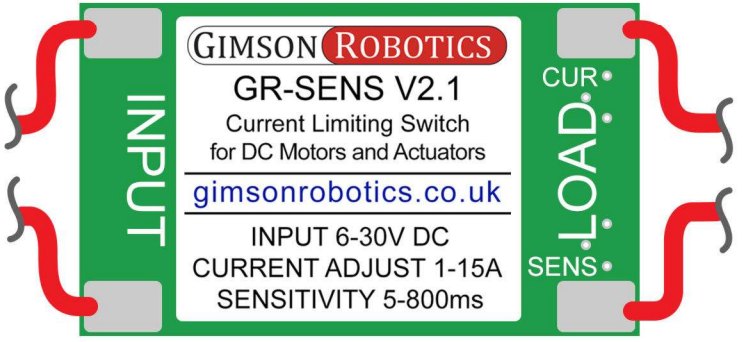
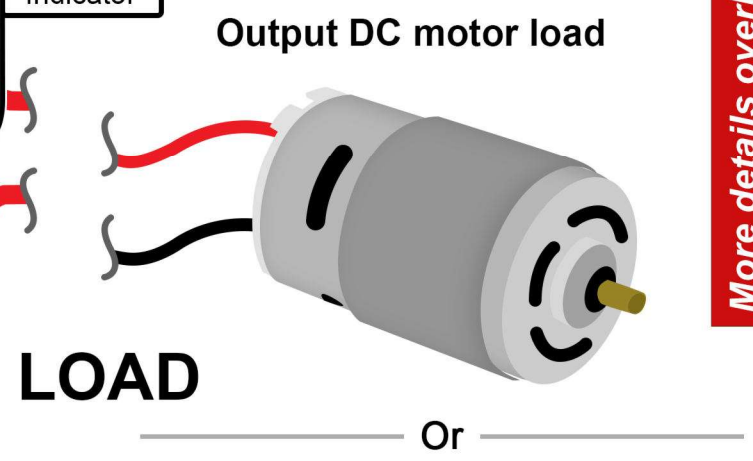
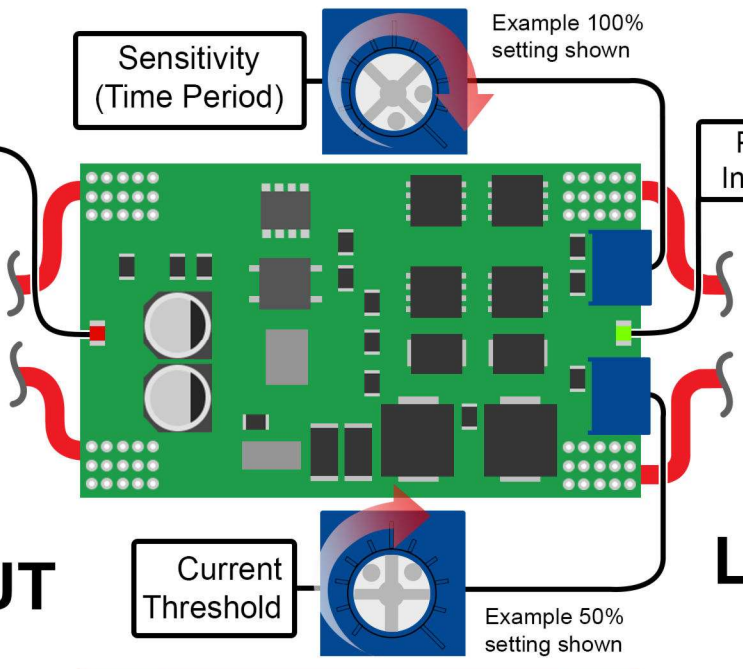
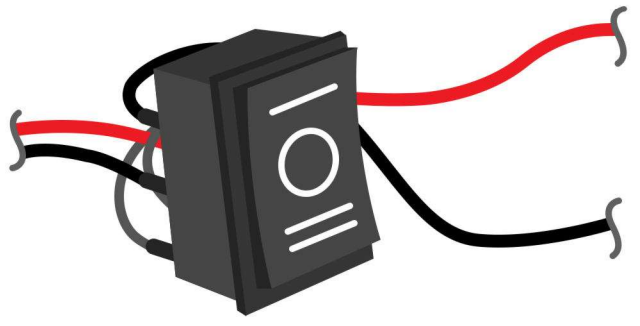
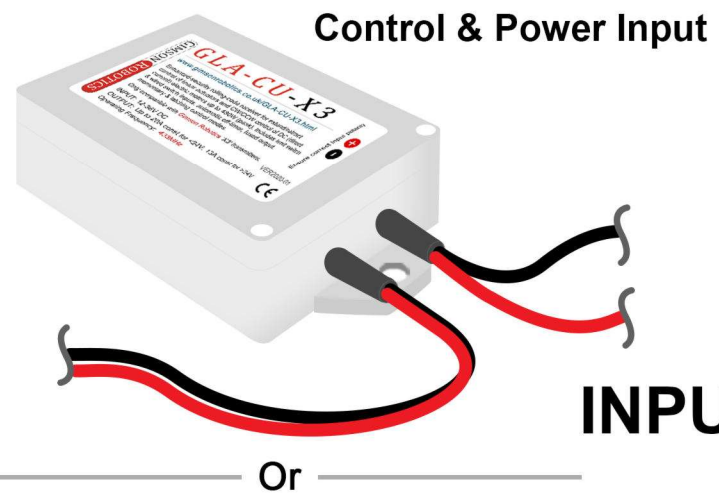

More details overleaf

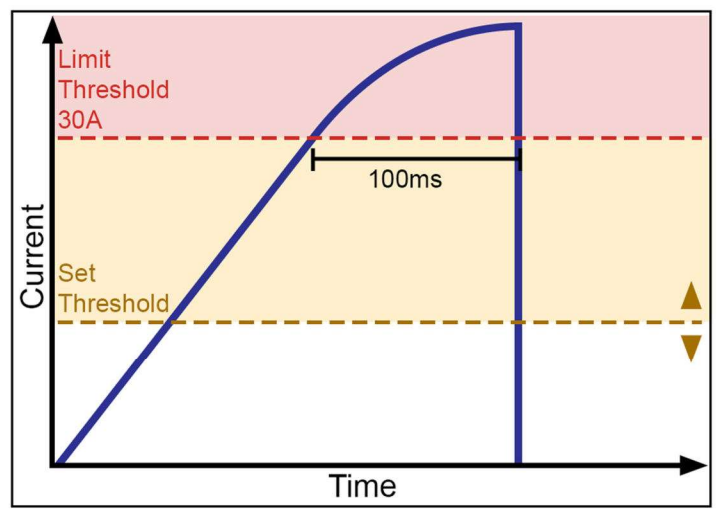
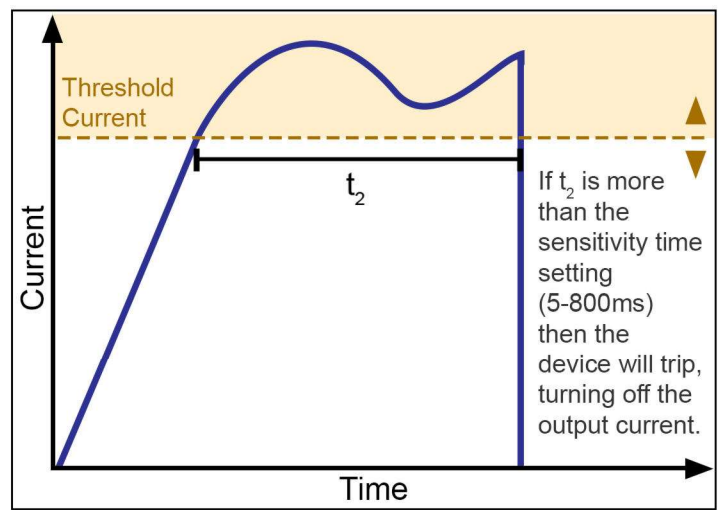
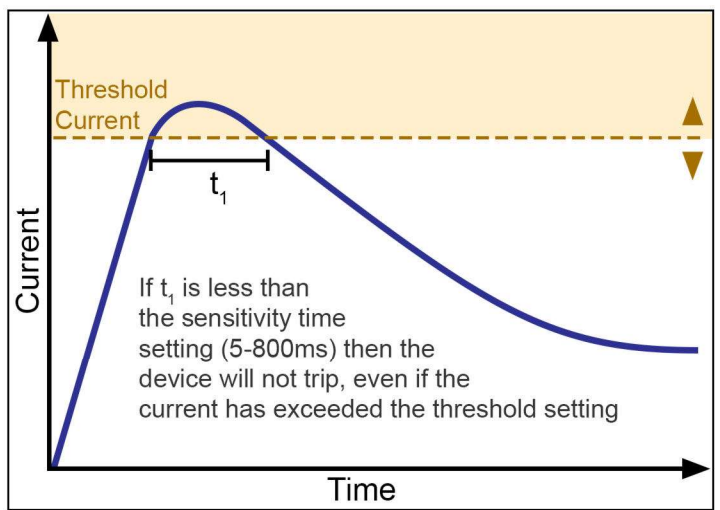



**Includes 30A 'micro' blade fuse**  
The 1-15A version of the GR-SENS features an in-line fuse as a failsafe, in case of hardware failure or damage only. It is a 'micro' size, also called type APS or ATT.



### Useful things to know

- When a DC (direct current) motor starts moving it demands a short spike (start-up surge) in current before stabilising, so for the GR-SENS your **Sensitivity Time** setting ought to be just-longer than this initial surge period so that you clear the start up hurdle whilst having a **Current Threshold** setting lower than the start-up current for maximum responsiveness.
- Motors do not enjoy being stalled or overloaded, if left in this condition for too long they can be permanently damaged. The GR-SENS is designed to help protect motors (and the driven assembly) in these situations but it is important that it is adjusted to appropriate values for your motor and load, in order to provide effective protection.

The process of calibrating your current limiter usually requires some trial and error, iterating towards the appropriate settings. We've described some example steps that you can take below:

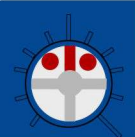

The area shown highlighted in red to the left, with two indented dots straddling a line, is the 'arrow' of each adjustment dial, indicating the position it is set to.

### Current Threshold (Amps)

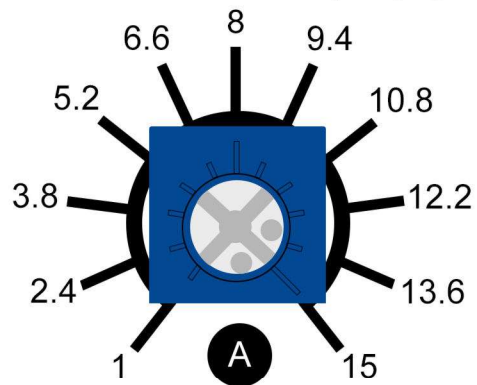

### STEP 1

**Set the current threshold value to a reasonable estimation of the limit required for the size of motor that you are using and the load it is under.**  
For example, if you have an actuator that is rated to demand 6A when under a 100kg load, but it is only pushing a 50kg load, then try starting with a current threshold setting of around 3A. It is better to under-estimate the value at this stage.

### Sensitivity Time (milliseconds)

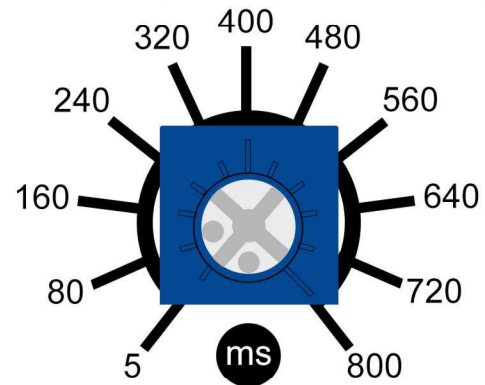

### STEP 2

**Set the sensitivity dial fully (or close to fully) anti-clockwise for high sensitivity.**

### STEP 3

**Test under the highest 'normal' expected load condition, if the device trips then adjust sensitivity gradually clockwise by small amounts at a time. If you're still getting interrupted operation then gradually adjust current limit clockwise (upwards) too, testing after each increment.**

### STEP 4

**Having found a combination of settings that works OK for your 'normal' load, try increasing the load beyond this intentionally to verify that the device trips as intended. If it is not sensitive enough, try adjusting the values down a little and testing again.**

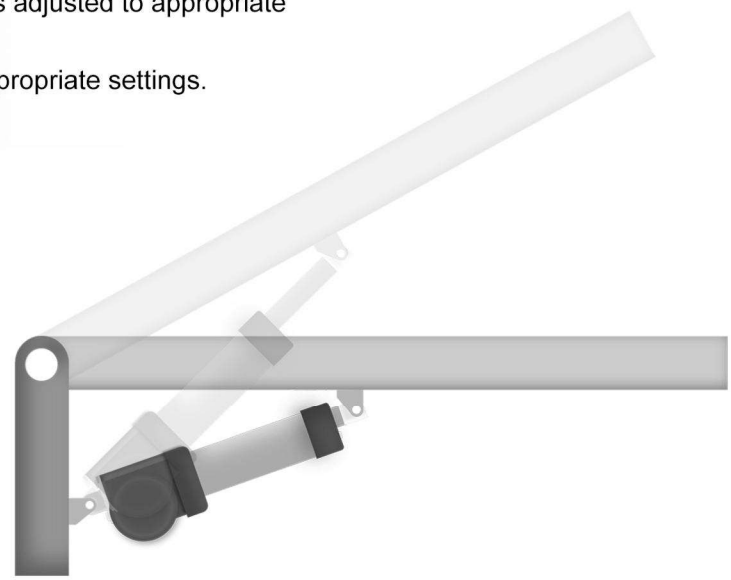

For example, a lifted hatch of the above layout usually puts greatest load on an actuator when first lifting from horizontal. If the **GR-SENS** is calibrated to *only-just* work (not trip) consistently at this peak load point then it should work OK through the rest of the travel while also being able to respond quickly to an overload.