

GLA3000-N 12V DC Actuator – Summary Specifications 2023

Updated 05.07.2023



Gimson Robotics Model	GLA3000-N 12V		
Motor	12V DC, brushed permanent magnet (24V option also available)		
Maximum Rated Load	3000N (305kg)		
No-load Speed, Current	9.5mm/s, 1 - 2A (no load current is greater during retraction)		
Speed, Current for Max. Load	4mm/s, 8A		
Stroke Length	Standard sizes: 100mm, 150mm, 200mm, 300mm, 400mm, 500mm Other sizes are available on a made-to-order basis		
Minimum Installation Length	Stroke Length + 200mm. Refer to drawing on page 2.		
Maximum Duty	10% (up-to 2 minutes continuous)		
Stall Current	~22A. Motor internal resistance 0.55Ohm. Sustained stall must be prevented, use overcurrent protection on input (current limiting via a controller, and/or a suitably rated fuse)		
Transmission	Single-stage low-noise (≤ 48 dB) worm-wheel gear reduction (39:1 ratio), driving a 7.5mm lead screw (2.5mm pitch, 3-start). Torsion spring on rear of screw to aid self-locking when in compression.		
Life Expectancy	30,000 strokes, nominal		
Weight	100mm stroke: 2180g 400mm stroke: 3000g	200mm stroke: 2450g 500mm stroke: 3280g	300mm stroke: 2730g
Materials, Enclosure Rating	Body: PA66+33%GF.	Rod and extruded sleeve: Aluminium.	IP54
Operating Temperature (Ta)	0°C ~ 40°C		
Cable	2m long 6-core lead (to connector), with 2 x 0.75mm ² cores (Brown and Blue, to motor) plus 4 x 0.25mm ² cores (to quadrature encoder), when the standard option is selected. Male 6-pin connector (5557) included, see connection diagram on page 2. Lead length and connectors can be customised		
Sensors	Internal quadrature encoder, 5V supply voltage, 15.6 pulses per channel per millimetre of travel (31.2 pulses/mm across both channels). The encoder signal allows this actuator model to have its position tracked, allowing multiple actuators to be synchronised, when used with a suitable controller		
Limit Switches	Built-in, microswitches and diodes to automatically turn motor current off, unidirectionally, at the 0mm and Stroke Length (full travel) positions		
Product Standards	EN 55014-1 EN 55014-2	RoHS Directive 2015/863 (RoHS 3) Be aware that EMC performance is dependent upon connected hardware	

Dimensioned Drawing. Note that 'Installation Length' = Stroke Length + 200mm

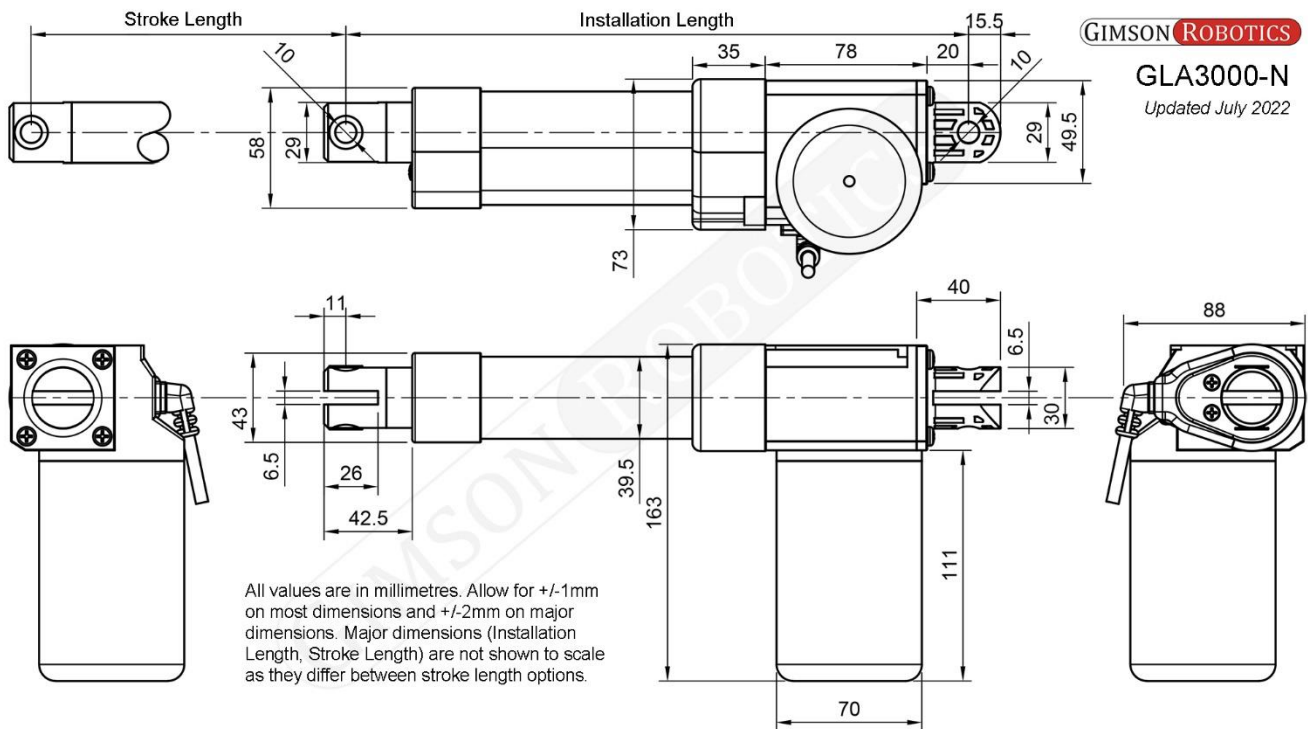

As indicated above, the standard mounting points at either end of the actuator are $\varnothing 10\text{mm}$ (diameter).

Mechanical & Electrical Characteristics

As with any brushed DC permanent magnet motor or actuator, there are some key principles that apply to the GLA3000-N, this includes the fact that:

- As load increases, travel speed decreases, this is an approximately linear relationship (see graph to right).
- As load increases, the current draw of the motor also increases, and this increase is also approximately linear between the no-load current up to the full load current.
- The level of measured current can help you to deduce the amount of mechanical load in the system.
- At a complete stall the peak current of the motor can be much greater than the normal load current (up to ~22A for the 12V version of GLA3000-N), in this condition the motor can rapidly overheat and be permanently damaged, and so overcurrent protection, and sensible mechanical design, should be used to avoid this.
- By changing the voltage reaching the actuator, the travel speed can be modified. When lower voltages (which can be via PWM duty cycling) are supplied, this does also mean that the current, and therefore the force, of the actuator also fall (e.g. approximately half-speed and half-force if the actuator were run at 6V). The actuator should not normally be overvolted, although as an exception a fully charged 12V battery is usually OK (which can be ~13.8V charged).

GLA3000-N 12V Force vs. Speed

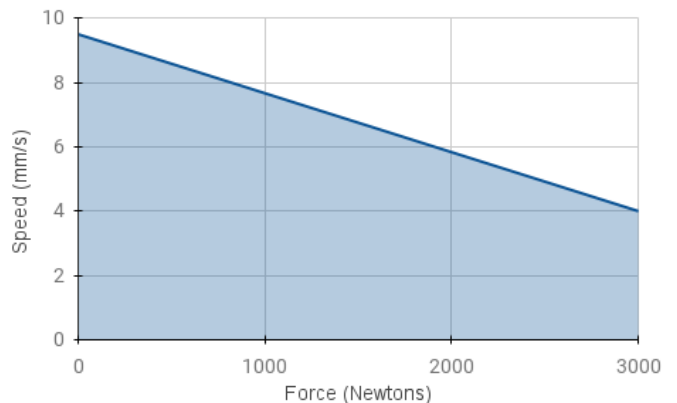

Further considerations, including those specific to the GLA3000-N, are that:

- This actuator is NOT suitable for bending/off-axis loading, and so in the case of a pivoting driven assembly, both ends of the actuator should be allowed to freely pivot with minimal friction, whereas in the case of a linearly-moving assembly, the assembly should be independently supported in the axial direction, in line with the actuator.
- Shock loads through the mounting points should be avoided (shock/impact loads may impart a force greater than the rated load through the actuator).
- The actuator is designed with an internal coil spring clutch, to increase the resistance to back-driving when subjected to compressive loads. This means, in practice, that at low loads the current draw of the actuator is greater when reversing compared to extending. If your application involves tension (pulling) loads, be aware that back-driving in this direction is possible below 3000N of tension.

Integrated Encoder, for position detection and synchronisation

The actuator has a hall-sensor based quadrature encoder built-in to the motor. The encoder is powered by two of the six cores of the main cable (+Vcc **Red**, -GND **Black**) and accepts a supply voltage of 5V. It has a dual-channel output (channel A **Yellow** lead, Channel B **Orange** lead), with each channel generating **15.6** pulses per millimetre of travel (3 complete pulses per motor revolution). One of the channels is out of phase with the other, as such it is possible to tell both the speed (from pulse frequency) and direction (by reading the pulses of one channel and comparing it to the other) of the motor. The nature of the signals that are generated is illustrated below. Given a maximum no-load travel rate of 9.5mm/s for the 12V motor (when run at 12V) the maximum pulse frequency would be **~148.2Hz** per encoder channel (the frequency rate would be greater than this if your controller is counting all rising/falling edges as opposed to only HIGH / LOW signal state changes). When used with the appropriate controller the encoder signals can be used for positional control with much greater accuracy and consistency than potentiometer-based actuator feedback systems.

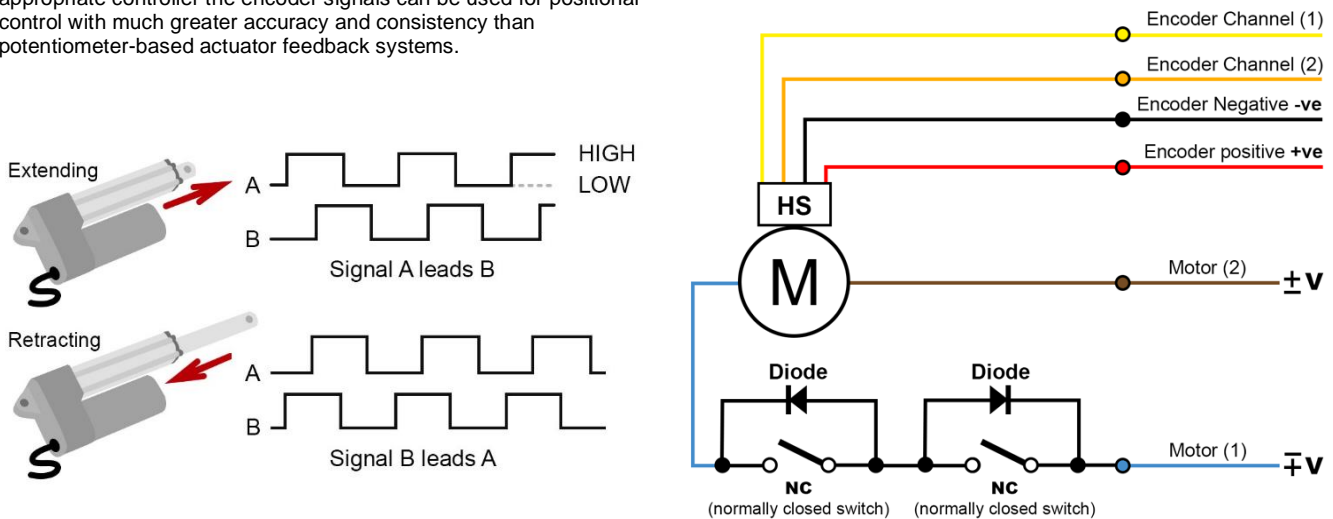

Connectors. A Male connector is included at the end of the standard actuator lead, Female connectors are available separately.

Male Connector

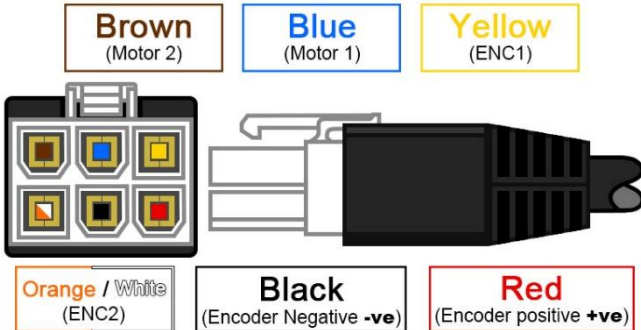

Female Connector

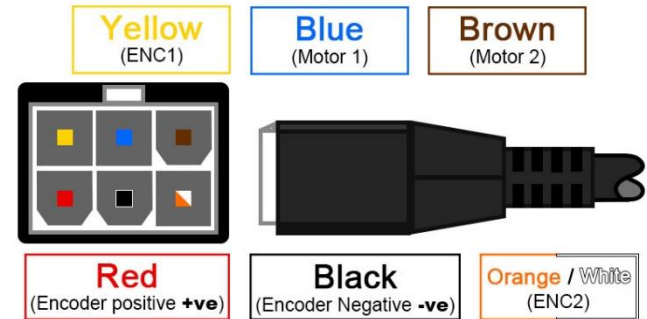

Safety Considerations

Linear actuators such as this model are low-voltage electromechanical components that are used in a wide variety of different applications. It is important that the safety of each installation is assessed according to its own requirements, construction, end user and environment.

To ensure that a system utilising these actuator(s) is safe here are some principles that should be followed (*this is not an exhaustive list*):

- i. The actuator should not be overloaded mechanically, or run above its specified duty cycle limit. Both it and any connected hardware should be designed with an appropriate safety factor (margin above the design load) for the application.
- ii. As actuators such as this are capable of generating a very large force, care should be taken to mitigate any possible entrapment or falling mass hazards that could be created by the assembly that you are installing them into.
- iii. Overcurrent protection must be used, ideally tuned to each system (current limiting), but at a minimum an appropriately rated fuse.
- iv. Power and control hardware should be appropriately specified to handle the load current required of the actuator.
- v. Mechanical overrides should be factored in to a design, where appropriate, due to the self-locking nature of the actuator.
- vi. End product and application-specific regulations should be checked, and appropriate risk assessments and compliance testing carried out on the basis of the planned usage.

If you have any questions, would like to place an order, or if you need help in determining the suitability of this item for your application, please contact us at support@gimsonrobotics.com