

# UltraTap

Filtered Boiling, Chilled or Hot Water Instantly



*Reliability through Simplicity*



## Simplicity

Instead of solenoids, level sensors and pumps we use the town water pressure to operate this simple and exceptionally reliable boiling and chilled drinking water system.

UltraTap series 2 further improves upon earlier technology and systems released into the market place over a decade ago.

### Boiling

No more waiting for the jug to boil or being late for the next meeting, adding convenience and efficiency.

### Chilled

Filtered, pure tasting chilled water on tap when you need it. Whether a glass or jug, it's instantly available. No more jugs in the fridge or changing the bottle on the water cooler.

### Hot

Hot water instantly available at the sink tap. No wasting water or time waiting for the hot water to arrive, adding efficiency to rinsing dishes and saving cost of additional water heaters and plumbing.

## Contents

Simplicity	3
Safety	4
Healthy	7
Energy Efficient and Green	8
Other Benefits	10
Warranty	13
Ultra Tap Models	14
Model Selection Table	22
Installation	24

## Safety

The UltraTap Series II is safer than any wall mounted boiler or kettle.



**Safety lock options** prevent the accidental dispensing of boiling water. You need to either press the red 'safety' button on the tap or press the remote safety before dispensing water.



**Total control over the flow rate delivered** avoiding splashes and spills from occurring. The tap features easy to operate levers so you can fill your cup or glass at just the right rate.



**Avoid the dangers of steam.** Simply lift the tap lever and boiling water comes out 'hands free' for any pre-set period of 5-60 seconds.





## Healthy

Having good quality clean, chemical free drinking water is not only good for you it is essential for quality tea and coffee.



**This leading technology water filter** removes up to 99.9% of chlorine, chloramines, cryptosporidium, giardia, asbestos, colour, taste and odour and other chemicals found in town water supplies.



**Every Ultra Tap system comes standard with a 5.0 micron water filter or upgrade to a 0.2 micron water filter** - the choice is up to you.



**The high capacity filters** are designed to last 12 months before changing is required meaning reduced service calls and reduced running costs.



**Filter change reminder.** We can send, call, SMS or email a friendly reminder when the filter is due to be replaced.



**The UltraTap filters last up to 10 times longer** and remove up to 14 times more than common carbon block filters found in other systems with a rated capacity of over 39,000 litres.



**All filtration options are globally certified by NSF International** against NSF/ANSI standard 42. The 0.2 micron option is certified against standard 42, 53 and P231.



**Hard water** found in many cities and rural towns significantly damages boiling water system through lime scale formation, requiring specialised filters to protect equipment. This protection comes standard with UltraTap filters.



**The sanitary quick change cartridge** makes changing as easy as changing a light bulb.

## Energy Efficient and Green

The UltraTap uses smart, reliable technology, saving on energy, water, time and money.



**In operational periods** the complete system uses less than 20% of the power used by one personal computer, a lot more efficient than a kettle.

When not in use the unit powers only the programmable timer at 17 watts per hour. Many devices in "sleep mode" or "standby mode" still use 30-40 watts of electricity every hour.

This energy saving results in lower CO<sub>2</sub> emissions and helps increase the performance rating of energy efficient buildings.



**The 7 day programmable timer** reduces energy consumption by shutting down the entire system when not in use. This reduces running costs and saves power.



**Heat transfer** from the hot system to the cold system is minimised through separate fully insulated boiling and chilled modules.



**No water wastage**, the system only dispenses water that is required at the set temperature preventing any water wastage running the tap until the temperature is right.



**The UltraTap is air cooled** avoiding water being wasted in cooling of the chilled water system. Some would say a more responsible use of a precious resource.



**Lower maintenance** and 12 month cartridge changes means less visits by technicians saving on CO<sub>2</sub> emissions and labour costs. The filters can be fully recycled.

This coupled with the lack of solenoids, sensors, circuit boards, wiring and pumps means we have the lowest carbon footprint.



### Energy Efficiency

This simple system costs less than \$1.50 per week to operate without water drawoff, based on a 12 hour operating cycle per day, 5 days a week.

The system maintains a boiling water temperature of 98°C and a chilled water temperature of 5°C during the operating cycle to allow instant usage.

Additional power cost of boiling filtered water is less than 0.5 cents per cup.

Additional cost of chilled filtered water is less than 0.2 cents per cup.

## Other Benefits



**Reliability through simplicity.** UltraTap is a combination of uncompromising quality, exceptional design leading to a level of reliability unmatched by our competitors with a warranty most could only dream about.



**Eliminating unnecessary** pumps, circuit boards, solenoids and sensors prevents down time and costly repairs.



**Infinitely adjustable flow rate** of the boiling and chilled water puts each tap operator in complete control of how fast the water is delivered. No more splashing or boiling water coming out too fast for some and too slow for others.



**Unlimited water** will be supplied for as long as the tap is held open, even if the rated capacity of the boiling and chilled water is exceeded, the system will still supply water.



**Modular compact design** provides the flexibility to be installed in the smallest of kitchens without compromising on features and can be tailored to suit the demands of any site now and in the future.



**The leak detection** device is simple, fail safe and installed under the sink on the supply valve to ensure your cupboards and floors will be protected 24/7 should a leak ever occur.



**Separate fully insulated boiling and chilled modules** minimises temperature drop in the hot tank and temperature rise in the cold tank. It also stops heat transfer from the hot system to the cold system.





## Warranty



**All UltraTap models** are covered by a 7 year warranty, 3 year full parts and labour warranty, plus an additional 4 year warranty on the boiling and chilled water tanks. Simply register online or call our customer care team on 1800 661 735. Filter cartridges are a consumable and are covered by a 30 day warranty.



**A 5 year, 60 month extended full parts and labour warranty** can be purchased for a nominal cost covering the complete unit for 5 years. This provides peace of mind and certainty in facility budgets.



Aqua Safe offers a **convenient 12 monthly filter replacement service** along with an **Australia wide service technician network** providing installation, repairs or maintenance to any UltraTap system.

## Industry Compliance

The UltraTap system complies with or exceeds all international and relevant Australian standards including various Environmental Choice performance guidelines.

The quality of design and engineering of the UltraTap system is reflected by our industry leading warranty, certification and standards.

These include NSF standard 42, 53, P231, Watermark, C-tick Approved, tested to AS3498 & AS4020, and complies with AS1428 requirements for disabled access.



watermark



c-tick compliant

# UltraTap Models

Aqua Safe has a comprehensive range of models to suit every application, whether it be your office kitchen, restaurant or showroom. Simply choose the required system, followed by the required capacity or refer to the model selection table on page 22 for more information.



## Boiling only, or Boiling+ Ambient

<b>Product Code</b>	78110	78112	78114	78116	78118
<b>Number of persons in office</b>	Up to 30	Up to 60	Up to 80	Up to 115	Up to 160
<b>Boiling water delivery - cups per hour</b>	110	130	150	190	260
<b>Ambient water delivery - glasses per hour</b>	unlimited	unlimited	unlimited	unlimited	unlimited
<b>Power supply (220-240 VAC GPO)</b>	10 Amp single	10 Amp single	10 Amp single	15 Amp single	20 Amp single







### Boiling and Chilled

<b>Product Code</b>	78120	78121	78122	78124	78126	78128
<b>Number of persons in office</b>	Up to 30	Up to 60	Up to 80	Up to 80	Up to 115	Up to 160
<b>Boiling water delivery - cups per hour</b>	110	130	150	150	190	260
<b>Chilled water delivery - glasses per hour</b>	65	65	65	120	120	155
<b>Power supply (220-240 VAC GPO)</b>	10 Amp single	10 Amp single	10 Amp single	10 Amp double	15 Amp single + 10 Amp single	20 Amp single + 10 Amp single



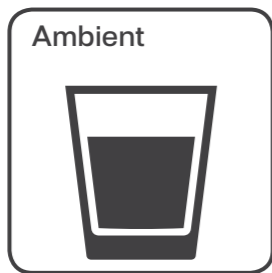

### Boiling, Hot and Cold (3-in-1)

Product Code	78140	78142	78144
Number of persons in office	Up to 80	Up to 115	Up to 160
Boiling water delivery - cups per hour	150	190	260
Ambient water delivery - glasses per hour	unlimited	unlimited	unlimited
Hot Water Delivery - 50°C litres per hour	55	70	100
Power supply (220-240 VAC GPO)	10 Amp single	15 Amp single	20 Amp single





### Boiling+Chilled, Hot and Cold (4-in-1)

Product Code	78130	78132	78134
Number of persons in office	Up to 80	Up to 115	Up to 160
Boiling water delivery - cups per hour	150	150	150
Chilled water delivery - glasses per hour	65	120	120
Hot Water Delivery - 50°C litres per hour	55	70	100
Power supply (220-240 VAC GPO)	10 Amp single	15 Amp single + 10 Amp single	15 Amp single + 10 Amp single









# Model Selection Table







Step 1 Choose the required system	Step 2 Choose the capacity (Persons in office)	Step 3 Select the Model		Initial Boiling Delivery (cups)	Boiling Delivery (cups/hr)	Chilled Delivery (glasses/hr)	Ambient Delivery	50°C Delivery (litres/hr)	Heating Element (KW)	Dimensions (mm H / W / D)		
		Product Code	Model							Boiling/Hot	Chilled	
<b>Boiling Only</b> <b>Boiling+Ambient</b>	1-30	78110	UB 110	15	110	-	Unlimited	-	1.8	335/ 180/ 150	-	10 Amp single
	30-60	78112	UB 130	23	130	-	Unlimited	-	2.4	325/ 245/ 290	-	10 Amp single
	60-80	78114	UB 150	47	150	-	Unlimited	-	2.4	480/ 245/ 290	-	10 Amp single
	80-115	78116	UB 190	47	190	-	Unlimited	-	3.0	480/ 245/ 290	-	15 Amp single
	115-160	78118	UB 260	47	260	-	Unlimited	-	4.8	480/ 245/ 290	-	20 Amp single
<b>Boiling+Chilled</b>	1-30	78120	UBC 110/65	15	110	65	-	-	1.8	335/ 180/ 150	295/ 200/ 390	10 Amp single
	30-60	78121	UBC 130/65	23	130	65	-	-	2.4	325/ 245/ 290	295/ 200/ 390	10 Amp single
	60-80	78122	UBC 150/65	47	150	65	-	-	2.4	480/ 245/ 290	295/ 200/ 390	11 Amp single
	60-80	78124	UBC 150/120	47	150	120	-	-	2.4	480/ 245/ 290	250/ 500/ 180	10 Amp double
	80-115	78126	UBC 190/120	47	190	120	-	-	3.0	480/ 245/ 290	250/ 500/ 180	15 & 10 Amp single
	115-160	78128	UBC 260/155	47	260	155	-	-	4.8	480/ 245/ 290	315/ 470/ 330	20 & 10 Amp single
<b>Boiling and Chilled, Hot and Cold (4-in-1)</b>	1-80	78130	UBCH 150/65/50	47	150	65	-	55	2.4	325/ 245/ 290	295/ 200/ 390	10 Amp single
	80-115	78132	UBCH 150/120/70	47	150	120	-	70	3.0	480/ 245/ 290	250/ 500/ 180	15 & 10 Amp single
	115-160	78134	UBCH 150/120/100	47	150	155	-	100	4.8	480/ 245/ 290	315/ 470/ 330	15 & 10 Amp single
<b>Boiling, Hot and Cold (3-in-1)</b>	1-80	78140	UBH 150/55	47	150	-	Unlimited	55	2.4	480/ 245/ 290	-	10 Amp single
	80-115	78142	UBH 190/70	47	190	-	Unlimited	70	3.0	480/ 245/ 290	-	15 Amp single
	115-160	78144	UBH 260/100	47	260	-	Unlimited	100	4.8	480/ 245/ 290	-	20 Amp single

## Step 4

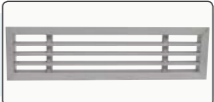
Select any options

Product Code	Name	
78170	Tap Mount Safety Switch	
78172	Remote Safety Switch	
78180	Integrated Round Font	
78182	Round Font	
78184	Square Font	
78186	Tap Extension - 85mm or nominate required height	
78188	Tubing Extension Kit - 1000mm	

Select any options

Product Code	Name	
78190	Kick board Vent; standard aluminium finish	
78192	Kick Board Vent Painted to Order - (see dulux.com.au for colour selection)	
78162	Disabled Tap with Right facing Spout	
78163	Disabled Tap with Left facing Spout	
78177	Disabled Tap Levers	
78178	Coloured Braille Pads for disabled tap levers	

# Installation

The boiler should be installed within 500mm of the tap or within 1000mm if using the tubing extension kit. All models should be installed with the nominated clearances on the sides and rear as shown on the drawings.

## Ventilation

Cupboard doors should be offset using the supplied 6-10mm buffers supplied or suitable ventilation holes or cut outs installed as shown on the drawings. Models with chiller units are supplied with auxiliary fan kits and silver or colour matched kick board vent to maintain efficiency.

For sink installation a 35mm-38mm hole diameter is required for the tap. For front installation, the hole size is dependent upon the chosen font.

## Disability Taps

Right angle taps are available for mobility impaired users or applications where the tap needs to be mounted near the front of the bench.

## Electrical

A twin 10amp GPO is required for models with a total rating of 2.4 kW or less. 3.0kW models require a 15amp and 10amp GPO. 4.8kW models require a 20amp GPO or can be hard wired through an isolator.

## 1. UltraTap Boiling Only and Boiling and Ambient models UB110, UB130, UB135

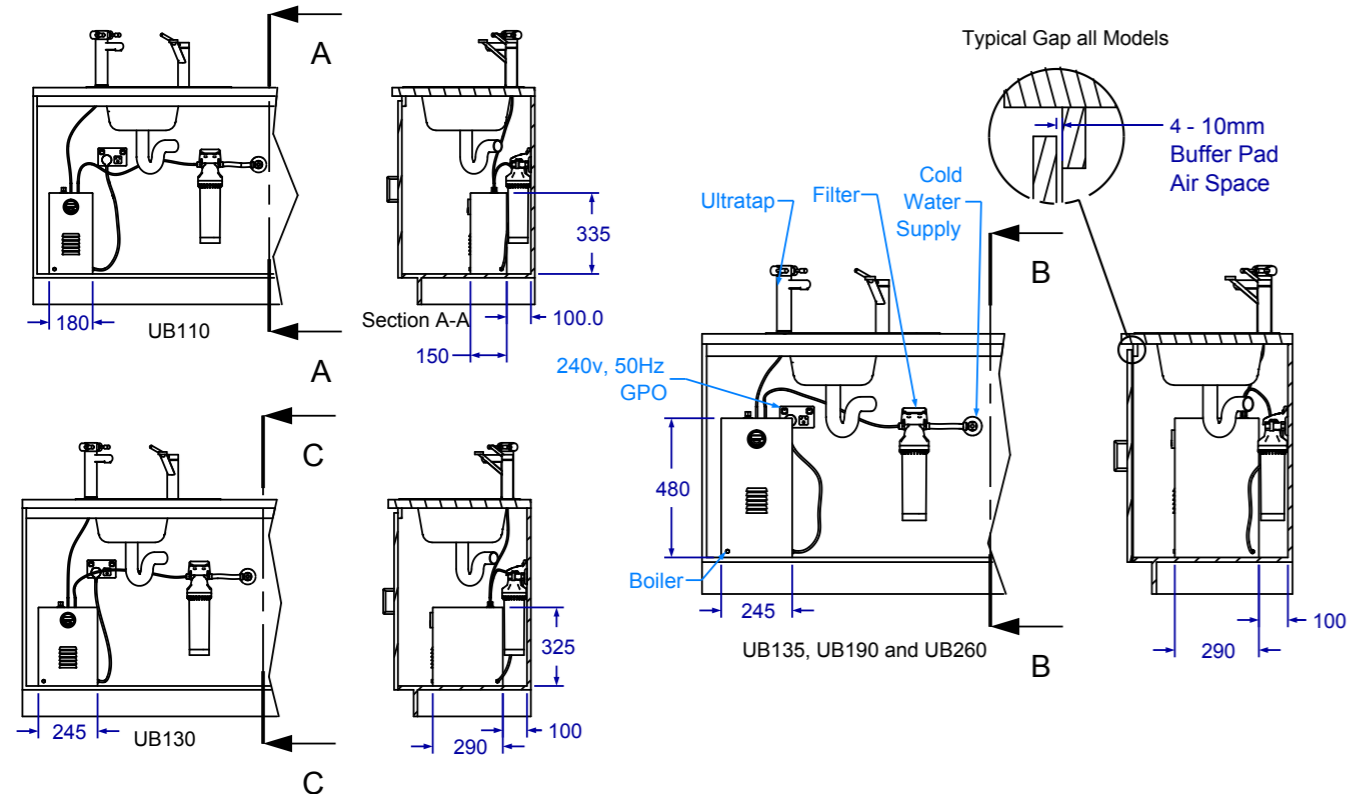

## 2. UltraTap Boiling and Chilled models UBC110-65, UBC130-65, UBC135-65

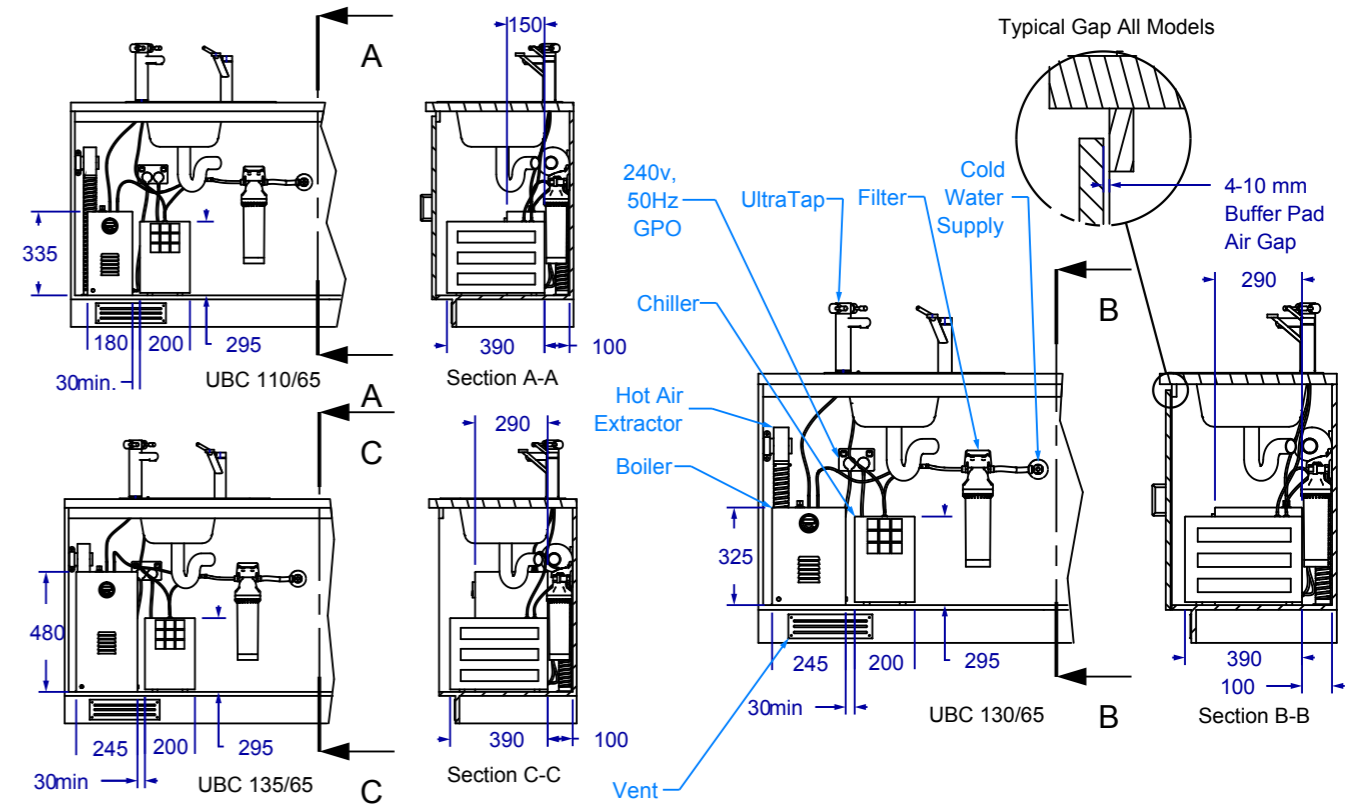

## 3. UltraTap Boiling and Chilled models UBC135-160, UBC190-160, UBC200-260

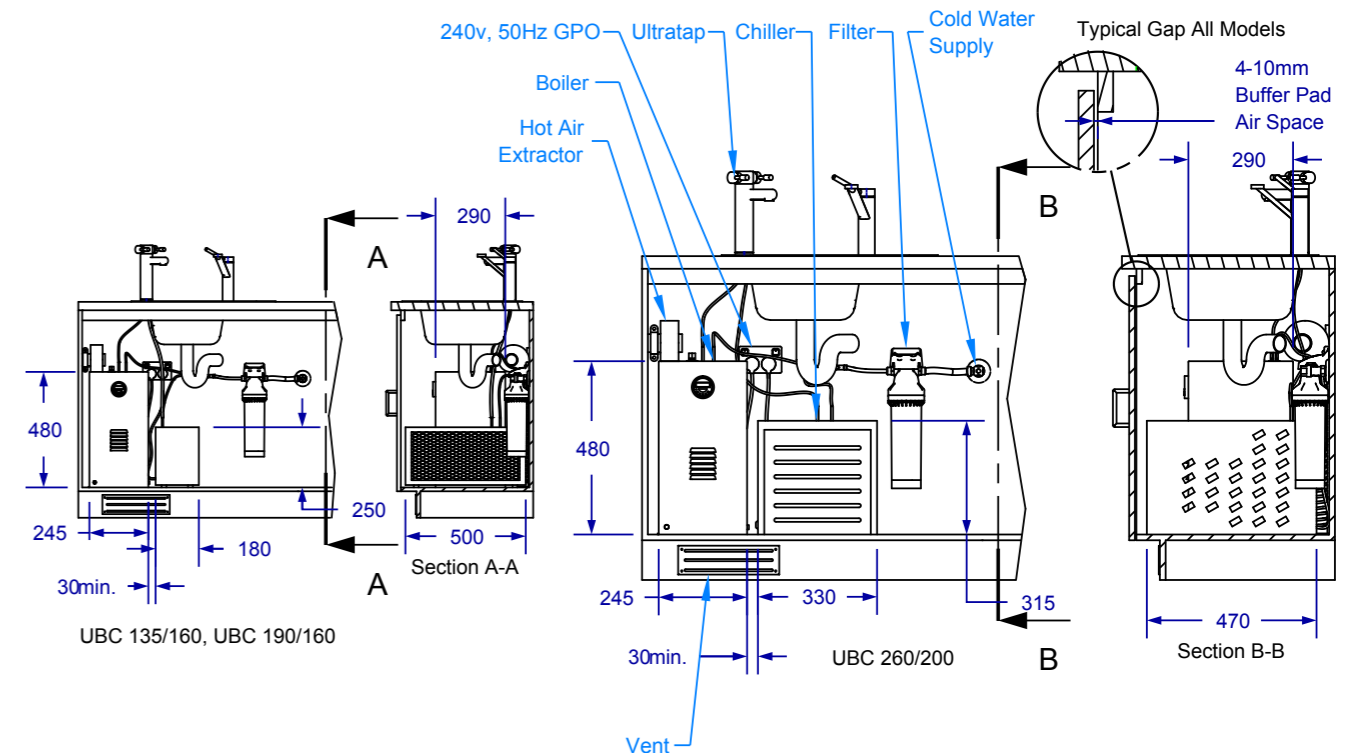

#### 4. UltraTap Boiling and Chilled, Hot and Cold (4-in-1) models UBCH135-12-160, UBCH190-12-160, UBCH260-12-200

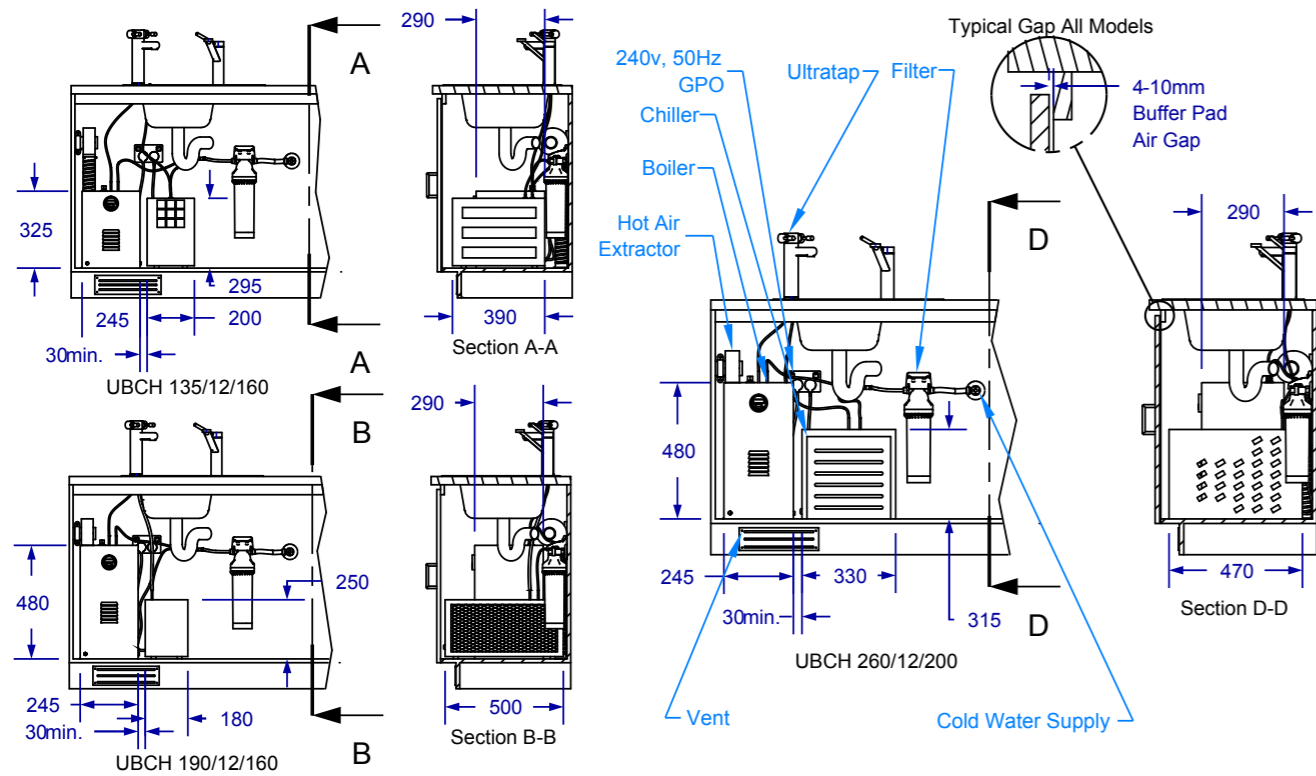

#### 6. UltraTap Font details

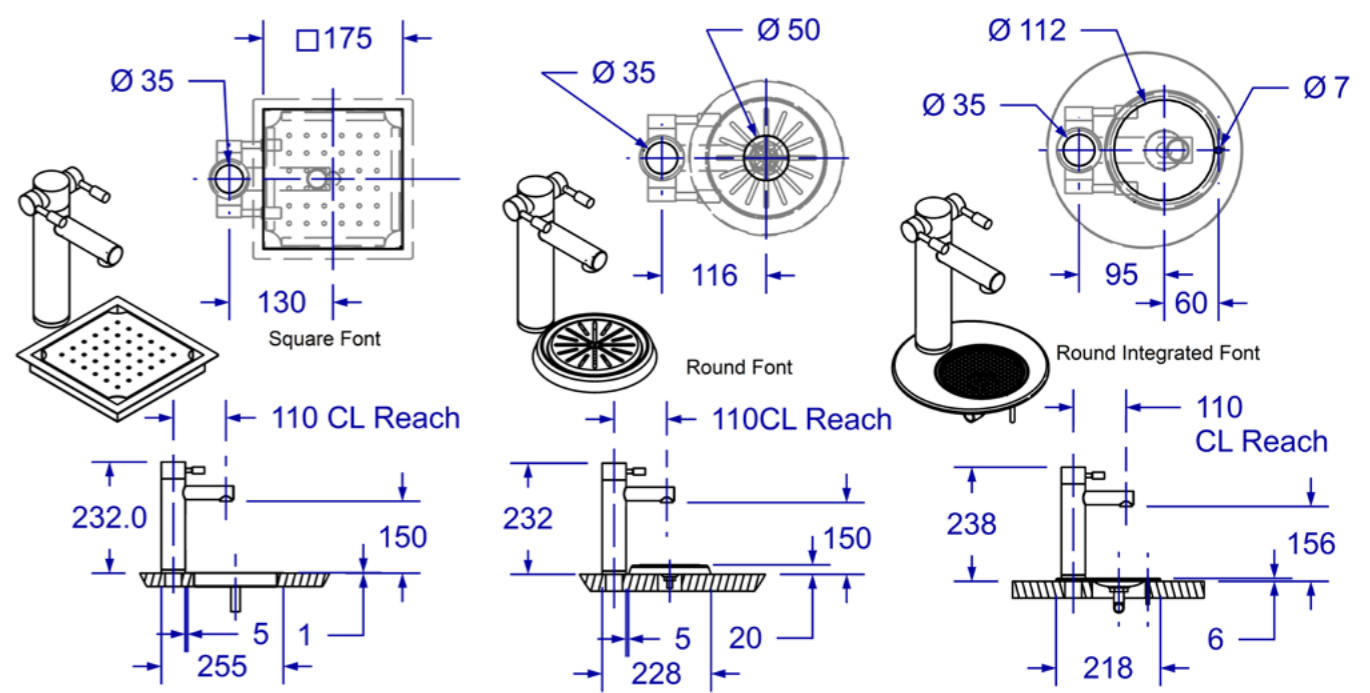

#### 5. UltraTap Boiling and Hot and Cold (3-in-1) models UBH135-12, UBH190-12, UBH260-12

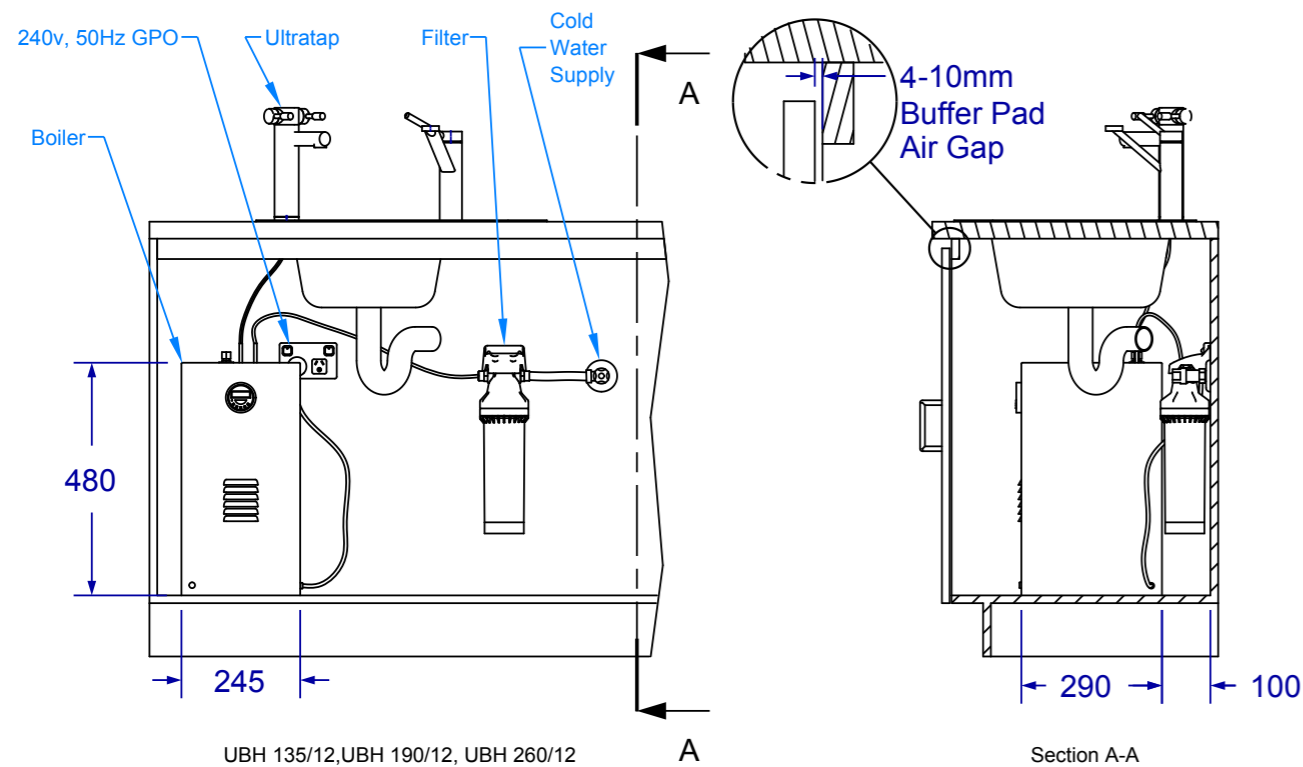

#### 7. UltraTap Disabled Tap details

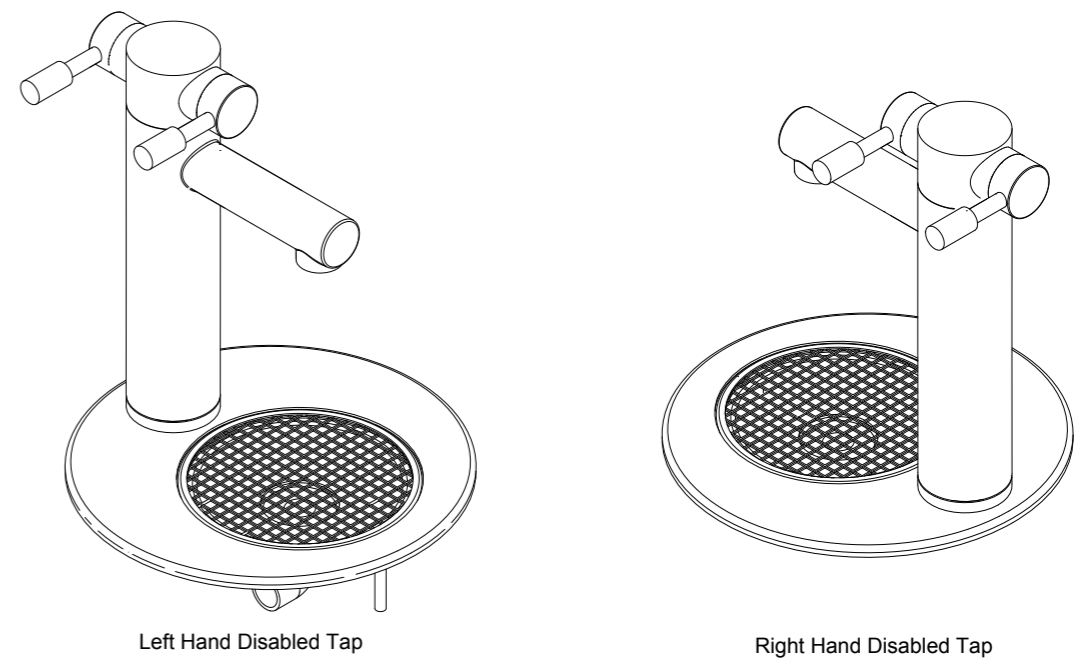

# UltraTap

Filtered Boiling, Chilled or Hot Water Instantly

Reliability through Simplicity

1300 661 735  
[www.aquasafe.com.au](http://www.aquasafe.com.au)

**Head Office**  
56 Wollongong Street, Fyshwick ACT 2609

