

LEGS MADE OF 1.5" THICK 2x10 MATERIAL
(SPRUCE, PINE OR FIR RECOMMENDED)
(4) TOTAL LEGS NEEDED

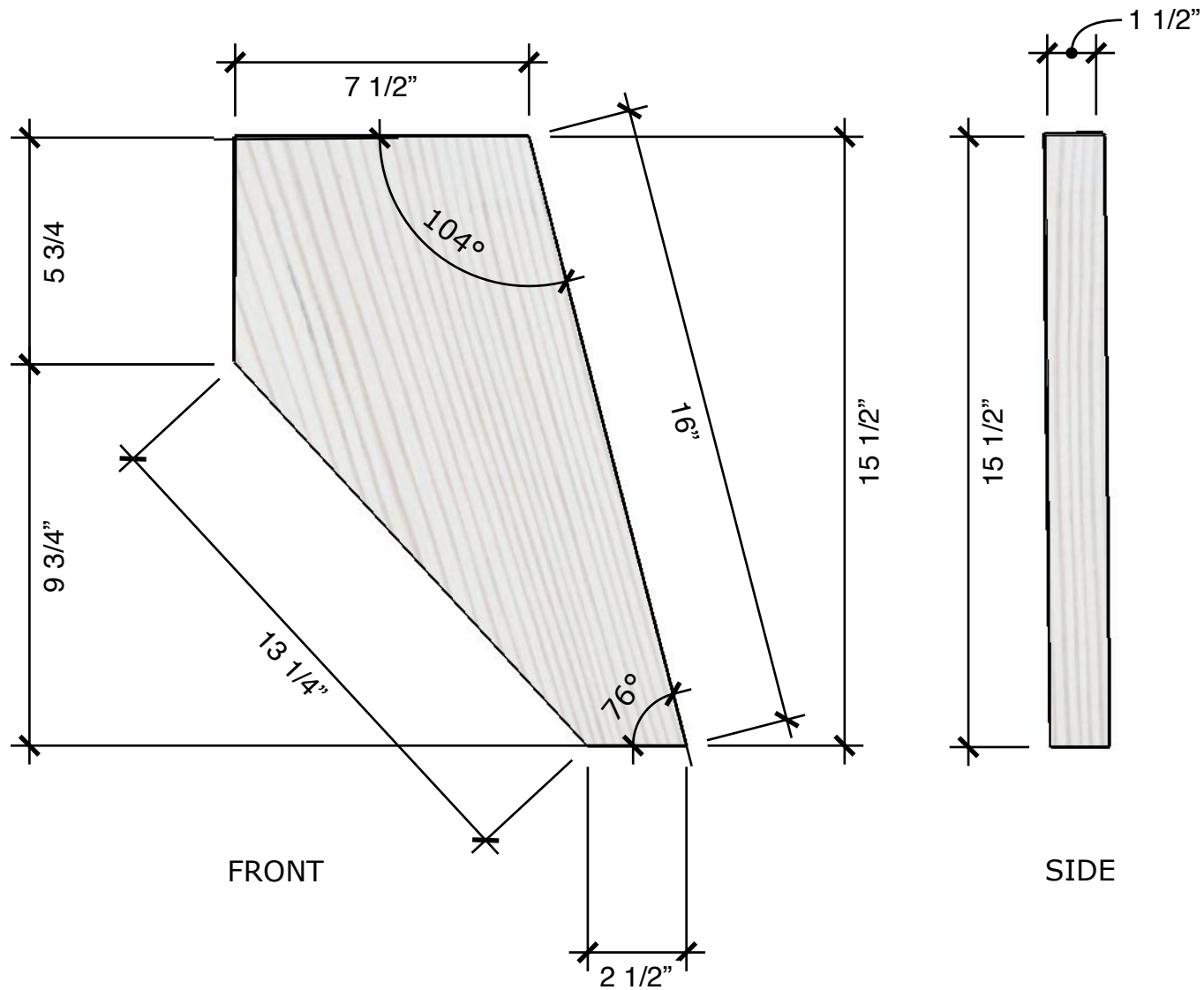

SEAT MADE OF 1.5" THICK 2x8 OR 2x10 MATERIAL
(SPRUCE, PINE OR FIR RECOMMENDED)
SEAT CONSISTS OF (2) 7" HALF CIRCLES

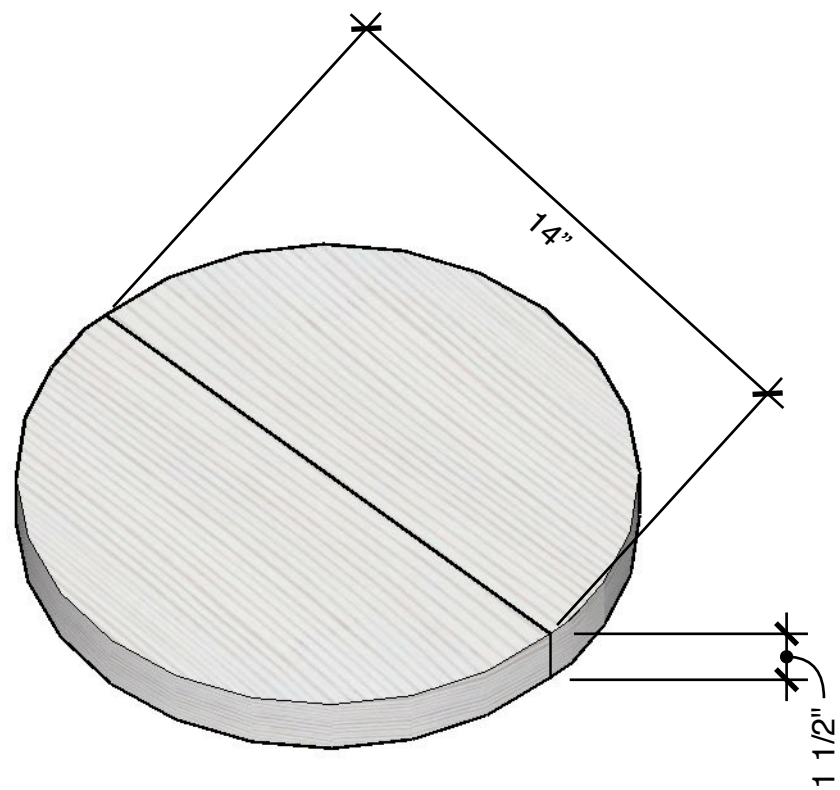

CENTER BLOCK MADE OF 1.5" THICK 2x8 OR 2x10 MATERIAL
1 NEEDED (SPRUCE, PINE OR FIR RECOMMENDED)

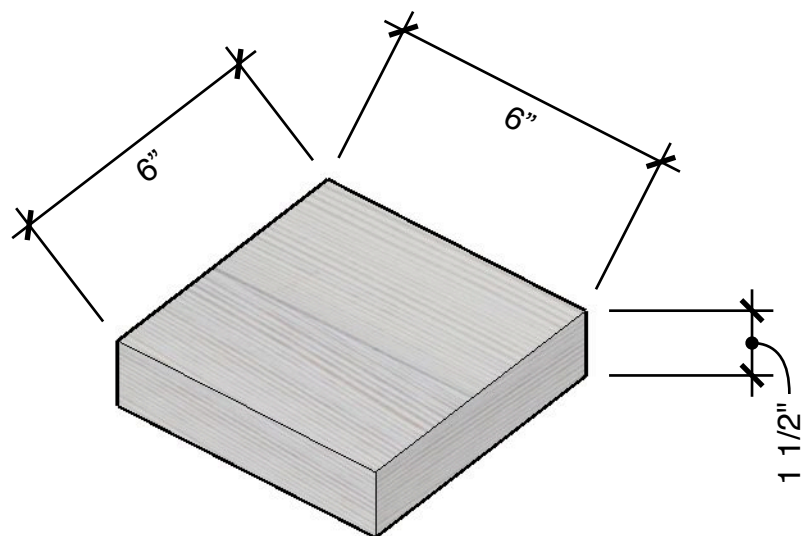

CENTER BLOCK
ALLOWS FOR EASE OF
ASSEMBLY



(6) 2 1/2" GRK WASHER
HEAD SCREWS ATTACH CENTER
BLOCK TO SEAT PIECES. ALIGN
DIAGONAL OF BLOCK ON SEAM
BETWEEN HALF CIRCLES

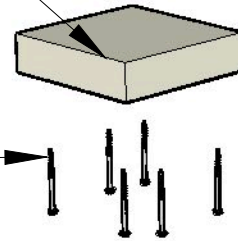

LEGS ATTACH TO CENTER BLOCK
WITH (4) 2 1/2" GRK WASHER
HEAD SCREWS

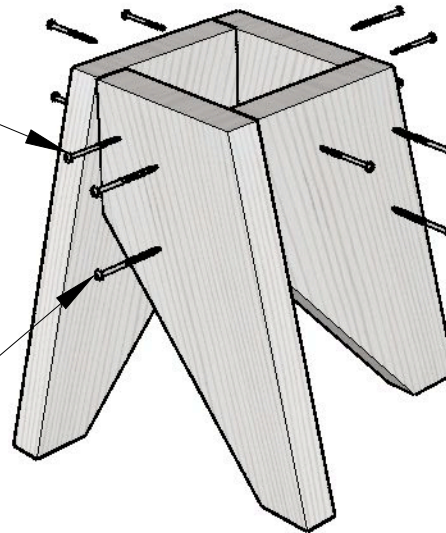

LEGS ATTACH TO EACH OTHER
WITH (8) 2 1/2" GRK WASHER
HEAD SCREWS.



BREAK/ ROUND OVER ALL
SHARP EDGES AND SAND TO
220

STOOL CAN BE LEFT RAW OR
FINISHED WITH WAX, STAIN,
PAINT OR POLYURETHANE.

