



# FORCE8

## DYNAMIC FX FAN

The Force 8 boasts exceptional wind strength and operates at a whisper-quiet volume, ensuring a silent yet highly efficient atmospheric effect. The Force 8's modular structure seamlessly integrates with all Master FX's products, extending the already synergetic Master FX ecosphere.

### TECHNICAL SPECIFICATIONS



**5 YEAR WARRANTY**



**HIGH VELOCITY WIND STRENGTH**



**MODULAR DESIGN**



### SPECIFICATIONS

- 1-100% Fan Speed Output Control
- 250W
- 50/60Hz
- Breaker: 15A 250V
- Voltage Detection
- 3000 CFM
- Max Noise Level: 72db at 3ft
- Fan Speed: 1550rpm
- Ambient Temperature Range: -4°F – 104°F
- 5 Pin DMX / 1CH
- Voltage Detection
- OLED Screen
- 5 Year Warranty
- Weight: 53lbs

### OVERVIEW + DIMENSIONS

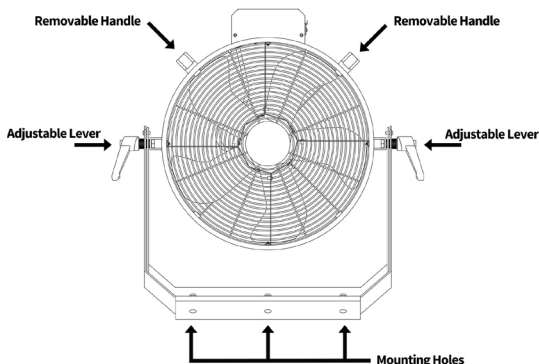
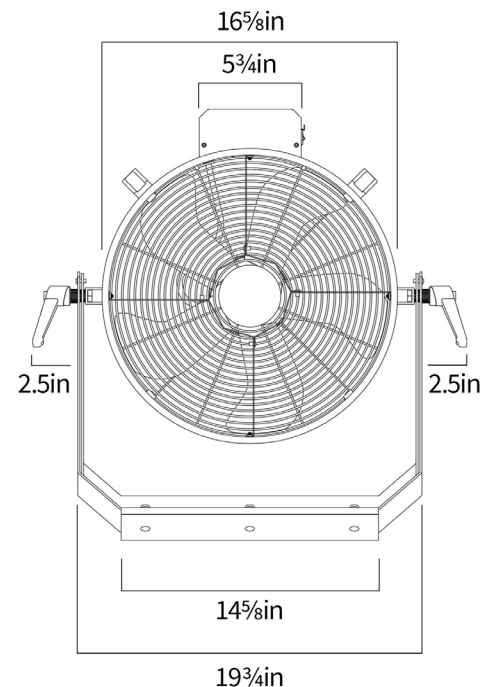
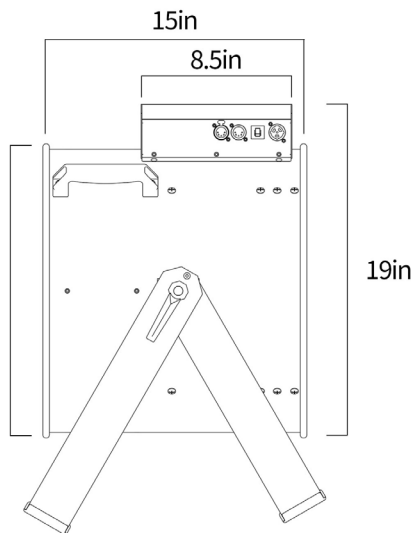
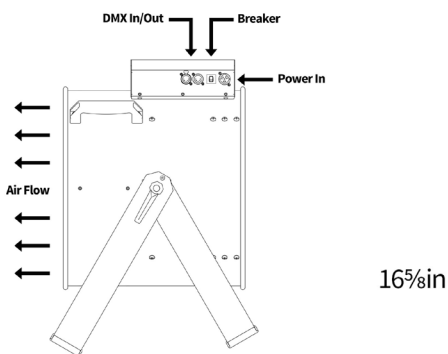

#### RIGGING

- Universal operating position
- Mounting brackets attach to stand
- Safety cable attachment point

#### OPTIONAL ACCESSORIES

- Universal Mounting Brackets

[DOWNLOAD CAD](#)