

Distributed by: Intech Bearing Inc., 4955 Gulf Freeway, Houston, TX 77023
ph.: 713.926.1136, toll-free: 800.327.7424, fax: 713.926.3110, www.intechbearing.com

Rod Ends, Sphericals, Rolling Element Bearings

HEIMTM BEARINGS

The First Name in Rod EndsTM



RBC[®]
BEARINGS

Heim[®] Bearings
ISO 9001:2000
AS9100

www.rbcbearings.com
800.390.3300

RBC Bearings has had a long tradition of innovation, commitment, and quality since the company was founded in 1919. Today, RBC Bearings has grown into a world-class manufacturer of standard and custom-engineered bearings and related products, with a product focus on research, testing, and development of the best product for specific applications.

What We Manufacture

RBC Bearings, with facilities throughout North America and Europe, provides bearings and precision products for applications in the construction, mining, material handling, transportation and off-highway equipment, robotics and automation, farming, machine tool, and semiconductor equipment industries. Through RBC Aerospace Bearings, the company is a major manufacturer of highly-engineered bearings and precision products for military, defense, and commercial aerospace applications.

RBC's high-quality bearings include:

- **Heavy Duty Needle Roller Bearings** - Pitchlign® caged heavy duty needle roller bearings, inner rings, type TJ TandemRoller® bearings for long life.
- **Spherical Plain Bearings** - Radial, angular, contact, high misalignment, extended inner ring, DuraLube™ maintenance-free spherical plain bearings, QuadLube® long life bearings, ImpactTuff® case carburized bearings, ShimPack® double-acting angular contact bearings, CrossLube® lubrication groove systems, and SpreadLock® Seal.
- **Cam Followers and Yoke Rollers** - Standard stud, heavy stud, yoke type, caged roller followers, RBC Roller® long life cam followers, HexLube® universal cam followers, airframe track rollers. Mastguide rollers and carriage rollers, chain sheaves (for leaf chain), toothless sprockets (for roller chain), and heavy-duty roller bearing construction.
- **Rod Ends** - Commercial and aerospace, precision, Mil-Spec series, self-lubricating, inch and metric. Heim®, Unibal®, and Spherco® brands.
- **Self-Lubricating Bearings** - Radial, thrust, rod ends, spherical plain bearings, high temperature, high loads, inch and metric. Fiberglide® brand.
- **Thin Section Ball Bearings** - Standard cross sections to one inch. Sizes to 40 inches. Stainless steel and other materials available. Seals available on all sizes and standard cross sections. Inch and metric.
- **Airframe Control Bearings** - Ball bearing types, self-lubricating types, needle rollers, track rollers.
- **Ground, Semiground, and Unground Ball Bearings** - Full complement, utilizes design and burnished races for higher loads, long life, and smooth operation.
- **Dowel Pins, Loose Needle Rollers, Shafts**
- **Tapered Roller and Tapered Thrust Bearings** - Case-hardened and through-hardened in a variety of sizes, used in Class 8 heavy truck and trailer wheel bearings, final drive transmissions and gear boxes.
- **Large Ball and Cylindrical Roller Bearings** - Ball and cylindrical roller bearings up to 60 in. (1.5 m) O.D. Tapered roller and tapered roller thrust bearings up to 36 in. (9.1 m) O.D. Slewing rings up to 169 in. (4.3 m) O.D.
- **Custom Designed Bearings** - RBC produces a wide range of custom bearings in various materials for specific applications.

Heim® Rod Ends

Heim® Bearings produces the industry's widest range of rod end types and sizes (inch and metric). The Heim® Bearings product range includes rod ends with brass race inserts in standard, precision, and high capacity designs; high strength two-piece designs; self-lubricating rod ends with engineered thermoplastic races or Teflon® liners; and military standard rod ends for the ultimate in rod end performance. Heim® rod ends are also available with a variety of platings, coatings, and materials, and with a wide range of optional features such as lubrication fittings, left hand threads, and keyway slots.

Heim® Spherical Bearings

Heim® Bearings uses a wide variety of designs and materials to offer a comprehensive line of spherical bearings. Standard Heim® spherical bearing designs include high strength steel-on-steel precision spherical bearings with brass race inserts; high capacity self-lubricating spherical bearings with Teflon® liners; and military standard spherical bearings. Standard material choices range from plain carbon steel to stainless steel.

Heim® Unibal® Ball Bearings

The Heim® Bearings unique unground ball bearing is a high capacity full complement unitized bearing which provides long life and smooth operation in an economical package. Solid races (not split) which are unbroken by loading slots provide longer life than other unground ball bearings and will accommodate thrust loading. Heim® ball bearings are available with plain and flanged ODs, and in an extra capacity design. Heim® also designs and produces a wide range of special ball bearings.

How We Can Serve You

RBC has implemented a total quality control system that uses statistical quality control at all facilities, and manufactures in high volume to a just-in-time program.

To serve the ongoing needs of customers, RBC has a network of over 1,600 distributors and sales engineers throughout North and South America and Europe, with authorized agents worldwide. For assistance with your bearing application, contact:

Customer Service - 800.390.3300

Warranty

RBC products are warranted for material and workmanship for a period not to exceed 90 days from shipment and for a value not to exceed purchase price. No other warranty is in effect.

Disclaimer and Intellectual Property Statement

The materials comprising this Catalog are provided by RBC Bearings as a service to its customers on an "as-is" basis for informational purposes only. RBC assumes no responsibility for any errors or omissions in these materials. RBC makes no commitment to update the information contained herein.

RBC makes no, and expressly disclaims any, representations or warranties, express or implied, regarding the Catalog, including, without limitation, any implied warranties of merchantability or fitness for a particular purpose. RBC makes no, and expressly disclaims any, warranties, express or implied, regarding the correctness, accuracy, completeness, timeliness, and reliability of the text, graphics and any other items in the Catalog. Under no circumstances shall RBC, its affiliates, or any of their respective partners, officers, directors, employees, agents or representatives be liable for any damages, whether direct, indirect, special or consequential damages for lost revenues, lost profits, or otherwise, arising from or in connection with this Catalog and the materials contained herein.

All materials contained in the Catalog are protected by copyright laws, and may not be reproduced, republished, distributed, transmitted, displayed, broadcast or otherwise exploited in any manner without the express prior written permission of RBC.

RBC's names and logos and all related trademarks (including RBC Part Numbers, Series Numbers, and Cone and Cup Numbers), tradenames, and other intellectual property are the property of RBC Bearings and cannot be used without its express prior written permission.

Teflon® is a registered trademark of DuPont.

TABLE OF CONTENTS

Page No.

Rod Ends

Selection Guide

HM, HF, HMX G, HFX G, BHM	Precision	4-5
HM C, HF C, M CR, F CR	Commercial	6-9
CMHD, CFHD	Engineered Thermoplastic Race	10-13
HM M, HF M, M M, F M	Aircraft	14-15
HME M, HFE M	Self-Lubricating	16-19
ME, FE	SAE-AS81935 (formerly MIL-B-81935)	20-21
SM, SMG, SF, SFG	Metric Precision	22-25
		26-27

Technical Section

Spherical Bearings

LSS, LS, LHA, LHB, LHSS, COS	Precision	32-35
LHSSE, LHSSVV	Self-Lubricating	36-37
COM, LH D, LH PP	Commercial	38-39
NE, NEG, NEE, NEEG (Narrow)	SAE-AS81820 (formerly MIL-B-81820)	40-43
WE, WEG, WEE, WEEG (Wide)	SAE-AS81820 (formerly MIL-B-81820)	44-47
SS	Metric Precision	48

Technical Section

Sleeve Bearings

General Information

PBE (Plain)	51	
FBE (Flanged)	SAE-AS81934/1 (formerly MIL-B-81934/1)	52
	SAE-AS81934/2 (formerly MIL-B-81934/2)	53

Technical Section

Self-Lubricating Bearings

		54
--	--	----

Ball Bearings

General Information

R	55	
RF	Standard O.D.	56
HK A	Flanged O.D.	57
	Extra Capacity	58

Applications

Special Bearings

		59
		60-61

Notes

		62-63
--	--	-------



Heim rod ends and spherical plain bearings are intended for linkage applications where a bearing must accommodate significant misalignment. While spherical plain bearings offer flexibility in housing and mounting design, the user bears the responsibility for housing design and the cost of housing manufacture. Rod ends offer greater mounting convenience and provide a compact, lightweight, economical design alternative to the spherical plain bearing. Heim Bearings Company offers the industry's widest selection of rod end types and sizes.

Rod End Construction

Heim offers three basic rod end constructions. The **four piece rod** end uses race inserts, typically of brass, to provide lubricity in the bearing area. This design offers reduced internal clearance, and provides smoother operation. It is ideal for dynamic applications. The **two piece rod** end uses a rod end body which is formed around a spherical ball. The comparatively heavy cross section of the rod end body in the two piece design provides high strength. This makes the two piece rod end ideal for highly loaded, static applications where high strength is required. The **cartridge type** rod end consists of a spherical plain bearing mounted in a rod end body. This design allows the optimum selection of materials for ball, race and rod end body. The cartridge type rod end can also accommodate a PTFE liner for self-lubrication. This design is best suited for aircraft and military applications where material selection is a primary design consideration.

Self-lubricating Rods Ends

Heim produces metal-to-metal rod ends and self-lubricating rod ends. All metal-to-metal rod ends, including brass insert four piece types, require regular lubrication. This can be accomplished by splash or immersion oil lubrication, or by greasing through optional lubricators (grease fittings). Self-lubricating types are used where relubrication is not practical, or in applications where relubrication is not desirable, such as on food processing machinery or in clean environments. Heim self-lubricating rods ends are available with bonded PTFE fabric liners, or with molded, engineered thermoplastic race inserts.

Rod End Grades

Heim rod ends are offered in four grades: precision, commercial, aircraft, and military. **Precision** rod ends are manufactured to tight tolerances for applications requiring improved linkage accuracy and reduced looseness. **Commercial** rod ends are produced using standard materials and manufacturing methods, and are an economical choice for industrial applications. **Aircraft** rod ends use premium materials, and have magnafluxed rod end bodies. Originally intended for aircraft applications, aircraft rod ends are used in many industrial applications where a high degree of reliability is required. **Military** rod ends are produced in strict accordance with all applicable military specifications and are typically used in military and commercial aviation applications, or when Mil-Spec approval is required.

Precision Rod Ends Grade HM and HF four piece precision rod ends use brass race

inserts for lubricity and clearance control. They are produced to tight tolerances for applications requiring a more precise rod end; for example, a linkage where positioning accuracy is essential. These rod end bodies and balls are plated for corrosion resistance. Series BHM, HFX G and HMX G four piece precision extra capacity rod ends are the high strength series intended for more heavily loaded, static and dynamic industrial applications. These rod ends have heat treated bodies for increased strength and aluminum bronze race inserts for high bearing capacity. The rod end bodies are protective coated for corrosion resistance and the balls are chrome plated for superior wear and corrosion resistance. Series BHM (male) and series HFX G (female) have common thread sizes. Series HMX G (male) have oversized shanks for additional shank strength.

- Series HM and HF: pages 6-7
- Series BHM, HFX G and HMX G: pages 8-9

HEIM UNIBAL® ROD ENDS

ROD END QUICK SELECTION GUIDE

Series Size Range	Product Features	Customer Benefits	Common Applications
HM, HF 3/16" to 1"	Precision Grade Brass Inserts Four Piece Construction	Low Friction, Long Dynamic Life, Smooth Feel, Good Conformity	Control Linkages, For Reduced Play, Accelerator Linkages
BHM, HFX G, HMX G 1/4" to 3/4"	Precision Grade Aluminum Bronze Inserts, High Strength Body, Four Piece Construction	High Capacity Version	Heavy Duty Applications
HM C, HF C 3/16" to 3/4"	Commercial Grade Brass Inserts Four Piece Construction	Low Friction, Long Dynamic Life, Smooth Feel, Good Conformity	Packaging Machine Linkages
M CR, F CR 3/16" to 3/4"	Commercial Grade Two Piece Construction	High Loads, Reversing Loads, Shock Loads, Cost Effective	Brake and Clutch Pedals For Heavy Machinery, Satellite Dish Controls
CMHD, CFHD 3/16" to 3/4"	Commercial Grade Self Lubricating Thermoplastic Race, Maximum Temperature 125°F	Maintenance Free	Food Processing, Paper Machinery, Bus Door Closures

HEIM SERIES	PAGE	LOADING				CORROSION RESISTANCE	SELF-LUBRICATING MIL-SPEC MIL-B-81935	MAXIMUM TEMPERATURE	SIZE RANGE	RACE MATERIAL	DESIGN
		STATIC	OSCILLATING	REVERSING	SHOCK						
COMMERCIAL AND PRECISION	HM HF	4-7	⊖	⊖	⊖	⊖		250°F	3/16" to 1"	BRASS	
	BHM HFX G HMX G	4-7	●	●	●	⊖		250°F	1/4" to 3/4"	ALUMINUM BRONZE	
	HM C HF C	8-11	⊖	⊖	⊖	⊖		250°F	3/16" to 3/4"	BRASS	FOUR PIECE
	M CR F CR	8-11	⊖	⊖	⊖	⊖		250°F	3/16" to 3/4"	STEEL	TWO PEICE
	CMHD CFHD	12-13	⊖	⊖	⊖	⊖	✓	125°F	3/16" to 3/4"	THERMO-PLASTIC	MOLDED RACE
AIRCRAFT AND MILITARY	HM M HF M	14-17	⊖	⊖	⊖	✓		250°F	1/8" to 1"	BRASS	
	M M F M	14-17	⊖	⊖	⊖	✓		250°F	3/16" to 1/4"	BRASS	FOUR PIECE
	HME M HFE M	18-19	⊖	⊖	⊖	✓	✓	250°F	3/16" to 1"	PTFE	
	ME FE	20-23	●	●	●	✓	✓	350°F	3/16" to 1"	PTFE	CARTRIDGE

Commercial Rod Ends Series HM C and HF C four piece commercial rod ends use Heim's classic brass race insert design for lubricity and clearance control. These rod ends are preferred for dynamic applications. Heim commercial rod ends have zinc plated bodies and nickel plated balls for corrosion resistance. Series M CR and F CR two piece commercial rod ends offer high strength for heavy static loads. Heim's unique manufacturing process for two piece rod ends yields the industry's best conformity between ball and body for maximum bearing capacity.

- Series HM C and HF C: pages 10-11
- Series M CR and F CR: pages 12-13

Series CMHD & CFHD self-lubricating commercial rod ends use an engineered thermoplastic race for applications where relubrication is not practical or desirable. The rod end body and ball are plated for corrosion resistance. This series is also available in stainless steel for superior corrosion resistance.

- Series CMHD and CFHD: page 15

Aircraft Rod Ends Series HM M and HF M four piece aircraft rod ends have magnafluxed rod end bodies for a high degree of assurance of rod end integrity. The bearing surface is a chrome plated ball on brass race inserts. This series was originally intended for general aviation applications and is also used in many industrial applications where rod end reliability is critical. Series M M and F M special purpose aircraft rod ends use materials and construction identical to series HM M and HF M but have different dimensions. Series HME M and HFE M self lubricating aircraft rod ends use Heim's UNIFLON® PTFE liner and cartridge type construction. The Heim UNIFLON® PTFE liner is approved to SAE-AS81820 (formerly MIL-B-18820).

- Series HM M and HF M: pages 16-17
- Series M M and F M: pages 18-19
- Series HME M and HFE M: pages 20-21

Military Rod Ends Series ME and FE mil-spec rod ends use Heim's Type E UNIFLON® PTFE liner and cartridge type construction. Rod end bodies are made from 4340 alloy

steel, heat treated to SAE-AMS-H-6875 (formerly MIL-H-6875), and are cadmium plated. The outer races are made from heat treated 17-4PH stainless steel (ASM 5643). The balls are made from heat treated 440C stainless steel (AMS 5630). The Heim UNIFLON® PTFE liner is approved to SAE-AS81820 (formerly MIL-B-81820). The ME and FE series mil-spec aircraft rod ends are approved to SAE-AS81935 (formerly MIL-B-81935). These premium rod ends are primarily intended for use in commercial and military aviation applications.

- Series ME: pages 22-23
- Series FE: pages 24-25

Metric Rod Ends Series SM, SMG, SF and SFG four piece, precision, metric rod ends use brass race inserts for lubricity and clearance control. They are produced to tight tolerances for applications where a precision rod end is required in a metric size. The two piece construction offers the added benefit of high strength for high loads. Heim also offers a wide variety of other metric rod ends. Contact Heim for availability and specifications.

- Series SMG and SFG: Pages 26-27

Optional Rod End Features

Heim rod ends are available with male and female threaded shanks. Standard rod ends have right hand threads. Left hand threads are available as an option. Lubricators are standard on selected series and are available as an option on all other series. Shank keyways are optionally available on most series to engage lock washer tangs. A wide range of other optional features includes plain shanks and special plating.

Precision Series

Four Piece - Metal-to-Metal

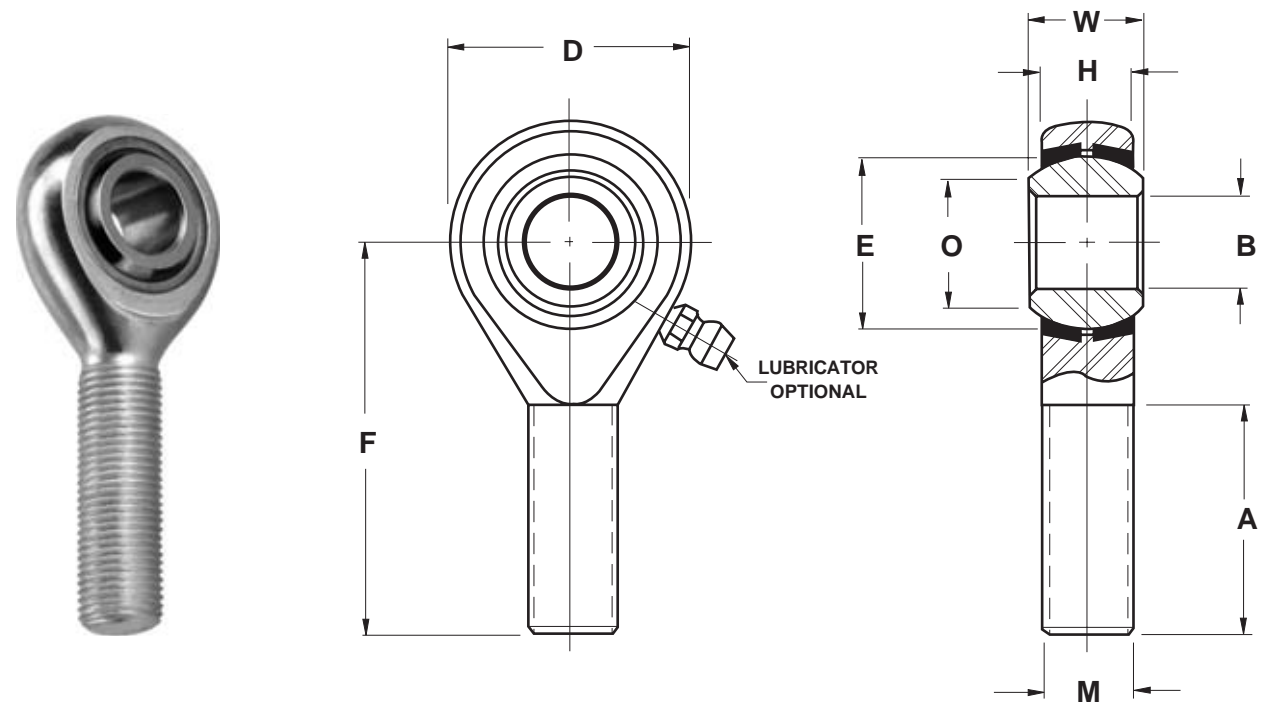

Series HM

ROD END NUMBER	DIMENSIONS IN INCHES										MAXIMUM STATIC RADIAL LOAD ⁷	APPROX WEIGHT
	BORE	BALL WIDTH	HOUSING WIDTH	HEAD DIAMETER	LENGTH TO CENTER OF BALL	THREAD LENGTH	THREAD SIZE	BALL DIAMETER	BALL FLAT DIAMETER			
	B	W	H	D	F	A	M	E	O			
	+0.015 -.0005	+0.000 -.005	+0.005 -.005	+0.010 -.010	+0.031 -.031	+0.062 -.031	UNF-3A	REF	REF		LBF	LBS
HM3	.1900	.312	.250	.625	1.250	.750	.1900-32	.437	.306		900	.03
HM4	.2500	.375	.281	.750	1.562	1.000	.2500-28	.515	.353		1,700	.05
HM5	.3125	.437	.344	.875	1.875	1.250	.3125-24	.625	.447		2,500	.08
HM6	.3750	.500	.406	1.000	1.938	1.250	.3750-24	.718	.516		4,000	.12
HM7	.4375	.562	.437	1.125	2.125	1.375	.4375-20	.812	.586		5,000	.17
HM8	.5000	.625	.500	1.312	2.438	1.500	.5000-20	.937	.698		7,000	.26
HM10	.6250	.750	.562	1.500	2.625	1.625	.6250-18	1.125	.839		8,050	.41
HM12	.7500	.875	.687	1.750	2.875	1.750	.7500-16	1.312	.978		11,300	.64
HM16 ⁶	1.0000	1.375	1.000 ⁵	2.750 ⁵	4.125	2.125	1.2500-12	1.875	1.275		28,400	2.25

Outer Member: Carbon steel, with protective coating for corrosion resistance

Ball: 52100 Alloy steel, heat treated, and chrome plated

Inserts: Brass

NOTES

- 1 Add letter "L" to prefix to indicate Left Hand thread
Example: HML4
- 2 For design options, see page 31
- 3 For Engineering data, see pages 28 thru 30
- 4 "H" tolerance across inserts is +/-0.015
- 5 Tolerances for 16 size: "D" +.030
-.010
"H" +.030
-.010
- 6 Outer Member: Alloy steel
Inserts: One piece carbon steel race
- 7 Load ratings reflect loads without lubricator.
For loads with lubricator contact Heim Engineering.

Precision Series

Four Piece - Metal-to-Metal

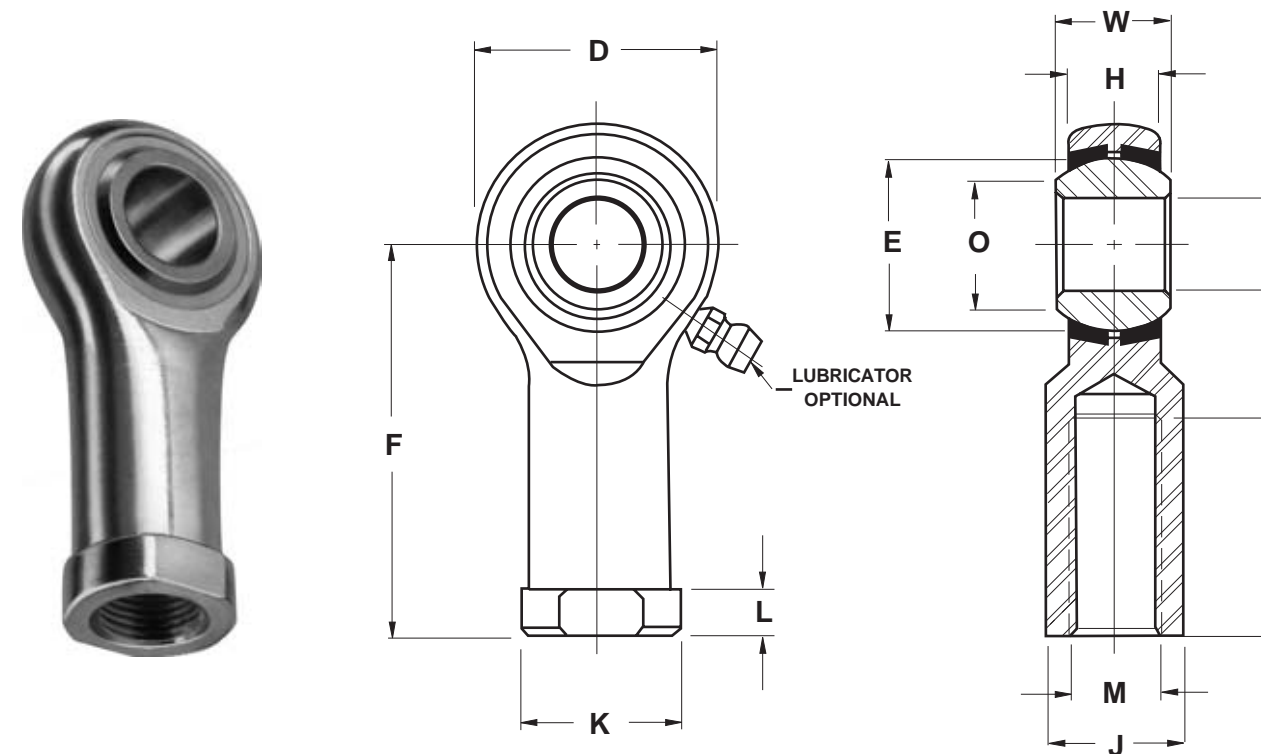

Series HF

ROD END NUMBER	DIMENSIONS IN INCHES												MAXIMUM STATIC RADIAL LOAD ⁷	APPROX WEIGHT
	BORE	BALL WIDTH	HOUSING WIDTH	HEAD DIAMETER	LENGTH TO CENTER OF BALL	THREAD LENGTH	THREAD SIZE	BALL DIAMETER	BALL FLAT DIAMETER	ACROSS WRENCH FLATS	OTHER DIMENSIONS			
	B	W	H	D	F	A	M	E	O	J	K	L		
	+0.015 -.0005	+0.000 -.005	+0.005 -.005	+0.010 -.010	+0.031 -.031	+0.062 -.031	UNF-3B	REF	REF	+0.010 -.010	+0.010 -.010	+0.010 -.010	LBF	LBS
HF3	.1900	.312	.250	.625	1.062	.562	.1900-32	.437	.306	.312	.406	.187	1,850	.03
HF4	.2500	.375	.281	.750	1.312	.750	.2500-28	.515	.353	.375	.468	.187	2,700	.05
HF5	.3125	.437	.344	.875	1.375	.750	.3125-24	.625	.447	.437	.500	.187	3,350	.08
HF6	.3750	.500	.406	1.000	1.625	.937	.3750-24	.718	.516	.562	.687	.250	4,450	.12
HF7	.4375	.562	.437	1.125	1.812	1.062	.4375-20	.812	.586	.625	.750	.250	5,350	.17
HF8	.5000	.625	.500	1.312	2.125	1.187	.5000-20	.937	.698	.750	.875	.250	7,400	.26
HF10	.6250	.750	.562	1.500	2.500	1.500	.6250-18	1.125	.839	.875	1.000	.312	8,050	.41
HF12	.7500	.875	.687	1.750	2.875	1.750	.7500-16	1.312	.978	1.000	1.125	.312	11,300	.64
HF16 ⁶	1.0000	1.375	1.000 ⁵	2.750 ⁵	4.125	2.125	1.2500-12	1.875	1.275	1.500 ⁵	1.625 ⁵	.437 ⁵	28,400	2.25

Outer Member: Carbon steel, with protective coating for corrosion resistance

Ball: 52100 Alloy steel, heat treated, and chrome plated

Inserts: Brass

NOTES

- 1 Add letter "L" to prefix to indicate Left Hand thread
Example: HFL 4
- 2 For design options, see page 31
- 3 For Engineering data, see pages 28 thru 30
- 4 "H" tolerance across inserts is +/-0.015
- 5 Tolerances for 16 size: "D" +.030
-.010
"H" +.030
-.010
"K", "J", "L" +/-0.015
- 6 Outer Member: Alloy steel
Inserts: One piece carbon steel race
- 7 Load ratings reflect loads without lubricator.
For loads with lubricator contact Heim Engineering.

Precision Extra Capacity Series

Four Piece - Metal-to-Metal

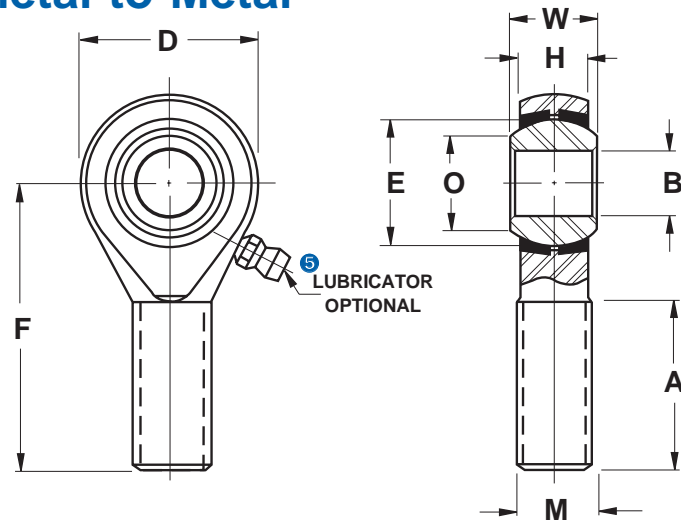

Series HMX G

ROD END NUMBER	DIMENSIONS IN INCHES										MAXIMUM STATIC RADIAL LOAD	APPROX WEIGHT
	BORE	BALL WIDTH	HOUSING WIDTH	HEAD DIAMETER	LENGTH TO CENTER OF BALL	THREAD LENGTH	THREAD SIZE	BALL DIAMETER	BALL FLAT DIAMETER			
	B	W	H	D	F	A	M	E	O	WITH LUBRICATOR		
	+0.015 -0.0005	+0.000 -0.005	+0.005 -0.005	+0.010 -0.010	+0.010 -0.010	+0.062 -0.031	UNF -3A	REF	REF			LBS
HMX4G	.2500	.375	.281	.750	1.562	1.000	.3125-24	.515	.353	3,260	6,680	.06
HMX5G	.3125	.437	.344	.875	1.875	1.250	.3750-24	.625	.447	4,920	8,410	.09
HMX6G	.3750	.500	.406	1.000	1.938	1.250	.4375-20	.718	.516	7,240	11,160	.13
HMX7G	.4375	.562	.437	1.125	2.125	1.375	.5000-20	.812	.586	7,620	13,660	.18
HMX8G	.5000	.625	.500	1.312	2.438	1.500	.6250-18	.937	.698	11,920	19,340	.30
HMX10G	.6250	.750	.562	1.500	2.625	1.625	.7500-16	1.125	.839	13,940	21,080	.46
HMX12G	.7500	.875	.687	1.750	2.875	1.750	.8750-14	1.312	.978	21,570	29,800	.72

Outer Member: 4130 or 4340 Alloy steel, heat treated, magnetic particle inspected, with protective coating for corrosion resistance

Ball: 52100 Alloy steel, heat treated, chrome plated

Inserts: Copper alloy

NOTES

- 1 Add letter "L" to prefix to indicate Left Hand thread
Example: HMXL4G
- 2 For design options, see page 31
- 3 For Engineering data, see pages 28 thru 30
- 4 "H" tolerance across inserts is +/-0.015
- 5 Delete letter "G" from suffix to indicate no lubricator
Example: HMX4

Series BHM

ROD END NUMBER	DIMENSIONS IN INCHES										MAXIMUM STATIC RADIAL LOAD	APPROX WEIGHT
	BORE	BALL WIDTH	HOUSING WIDTH	HEAD DIAMETER	LENGTH TO CENTER OF BALL	THREAD LENGTH	THREAD SIZE	BALL DIAMETER	BALL FLAT DIAMETER			
	B	W	H	D	F	A	M	E	O	WITHOUT LUBRICATOR		
	+0.015 -0.0005	+0.000 -0.005	+0.005 -0.005	+0.010 -0.010	+0.010 -0.010	+0.062 -0.031	UNF-3A	REF	REF			LBS
BHM4	.2500	.375	.281	.750	1.562	1.000	.2500 - 28	.515	.353	4,290	6,880	.05
BHM5	.3125	.437	.344	.875	1.875	1.250	.3125 - 24	.625	.447	6,880	10,500	.08
BHM6	.3750	.500	.406	1.000	1.938	1.250	.3750 - 24	.718	.516	10,500	13,660	.12
BHM7	.4375	.562	.437	1.125	2.125	1.375	.4375 - 20	.812	.586	13,660	19,340	.17
BHM8	.5000	.625	.500	1.312	2.438	1.500	.5000 - 20	.937	.698	19,340	21,080	.26
BHM10	.6250	.750	.562	1.500	2.625	1.625	.6250 - 18	1.125	.839	21,080	29,800	.41
BHM12	.7500	.875	.687	1.750	2.875	1.750	.7500 - 16	1.312	.978	29,800		.64

Outer Member: 4130 or 4340 Alloy steel, heat treated, magnetic particle inspected, with protective coating for corrosion resistance

Ball: 52100 Alloy steel, heat treated, chrome plated

Inserts: Copper alloy

NOTES

- 1 Add letter "L" to prefix to indicate Left Hand thread
Example: BHML4
- 2 For design options, see page 31
- 3 For Engineering data, see pages 28 thru 30
- 4 "H" tolerance across inserts is +/-0.015
- 5 Lubricator optional on BHM series
Example: BHM4G

Precision Extra Capacity Series

Four Piece - Metal-to-Metal

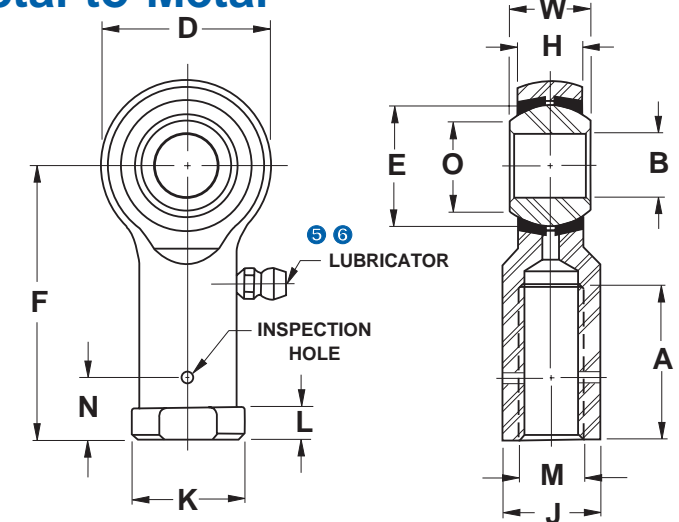

Series HFX G

ROD END NUMBER	DIMENSIONS IN INCHES														MAXIMUM STATIC RADIAL LOAD	APPROX WEIGHT
	BORE	BALL WIDTH	HOUSING WIDTH	HEAD DIAMETER	LENGTH TO CENTER OF BALL	THREAD LENGTH	THREAD SIZE	BALL DIAMETER	BALL FLAT DIAMETER	ACROSS WRENCH FLATS	OTHER DIMENSIONS					
	B	W	H	D	F	A	M	E	O	J	K	N	L	LBF		
	+0.015 -0.0005	+0.000 -0.005	+0.005 -0.005	+0.010 -0.010	+0.010 -0.010	+0.062 -0.031	UNF -3B	REF	REF	+0.010 -0.010	+0.010 -0.010	+0.020 -0.020	+0.010 -0.010			
HFX4G	.2500	.375	.281	.750	1.312	.750	.2500-28	.515	.355	.375	.468	.312	.187	6,680	.06	
HFX5G	.3125	.437	.344	.875	1.375	.750	.3125-24	.625	.447	.437	.500	.406	.187	8,410	.08	
HFX6G	.3750	.500	.406	1.000	1.625	.937	.3750-24	.718	.517	.562	.687	.469	.250	11,160	.14	
HFX7G	.4375	.562	.437	1.125	1.812	1.062	.4375-20	.812	.586	.625	.750	.531	.250	13,660	.18	
HFX8G	.5000	.625	.500	1.312	2.125	1.187	.5000-20	.937	.698	.750	.875	.594	.250	19,340	.29	
HFX10G	.6250	.750	.562	1.500	2.500	1.500	.6250-18	1.125	.839	.875	1.000	.750	.312	21,080	.43	
HFX12G	.7500	.875	.687	1.750	2.875	1.750	.7500-16	1.312	.978	1.000	1.125	.875	.312	29,800	.64	

Outer Member: 4130 or 4340 Alloy steel, heat treated, magnetic particle inspected, with protective coating for corrosion resistance

Ball: 52100 Alloy steel, heat treated, chrome plated

Inserts: Copper alloy

NOTES

- 1 Add letter "L" to prefix to indicate Left Hand thread.
Example: HFXL4G
- 2 For design options, see page 31
- 3 For Engineering data, see pages 28 thru 30
- 4 "H" tolerance across inserts is +/-0.015
- 5 Lubricator standard on HFX G Series
- 6 Delete letter "G" from suffix on HFX G Series to indicate no lubricator
Example: HFX4

Commercial Series

Four Piece - Metal-to-Metal

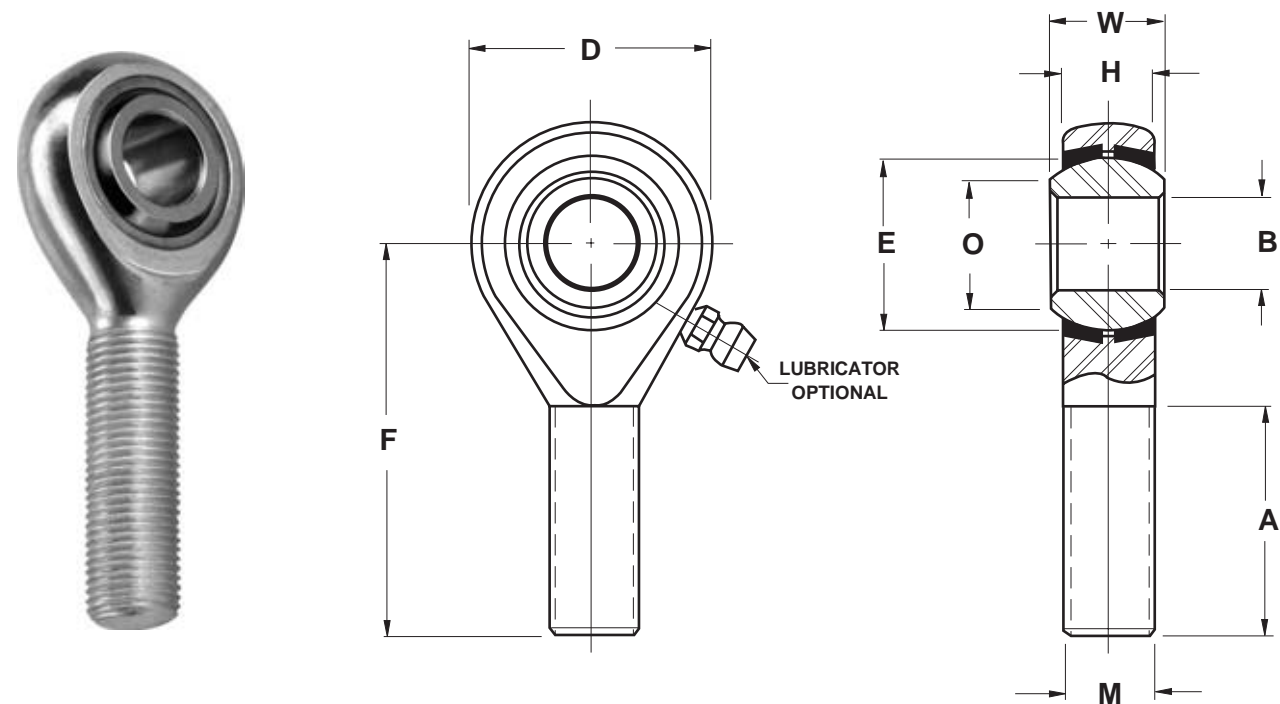

Series HM C

ROD END NUMBER	DIMENSIONS IN INCHES										MAXIMUM STATIC RADIAL LOAD	APPROX WEIGHT
	BORE	BALL WIDTH	HOUSING WIDTH	HEAD DIAMETER	LENGTH TO CENTER OF BALL	THREAD LENGTH	THREAD SIZE	BALL DIAMETER	BALL FLAT DIAMETER			
	B	W	H	D	F	A	M	E	O			
	+0.0025 -0.0005	+0.005 -0.005	+0.010 -0.010	+0.031 -0.031	+0.031 -0.031	+0.062 -0.062	UNF -3A	REF	REF		LBF	LBS
HM3C	.1900	.312	.250	.625	1.250	.750	.1900 - 32	.437	.306		900	.03
HM4C	.2500	.375	.281	.750	1.562	1.000	.2500 - 28	.515	.353		1,700	.05
HM5C	.3125	.437	.344	.875	1.875	1.250	.3125 - 24	.625	.447		2,500	.08
HM6C	.3750	.500	.406	1.000	1.938	1.250	.3750 - 24	.718	.516		4,000	.12
HM7C	.4375	.562	.437	1.125	2.125	1.375	.4375 - 20	.812	.586		5,000	.17
HM8C	.5000	.625	.500	1.312	2.438	1.500	.5000 - 20	.937	.698		7,000	.25
HM10C	.6250	.750	.562	1.500	2.625	1.625	.6250 - 18	1.125	.839		8,050	.41
HM12C	.7500	.875	.687	1.750	2.875	1.750	.7500 - 16	1.312	.978		11,300	.64

Outer Member: Carbon steel, with protective coating for corrosion resistance

Ball: 52100 Alloy steel, heat treated, chrome plated

Inserts: Brass

NOTES

- 1 Add letter "L" to prefix to indicate Left Hand thread
Example: HML4C
- 2 For design options, see page 31
- 3 For Engineering data, see pages 28 thru 30
- 4 "H" tolerance across inserts is +/-0.015

Commercial Series

Four Piece - Metal-to-Metal

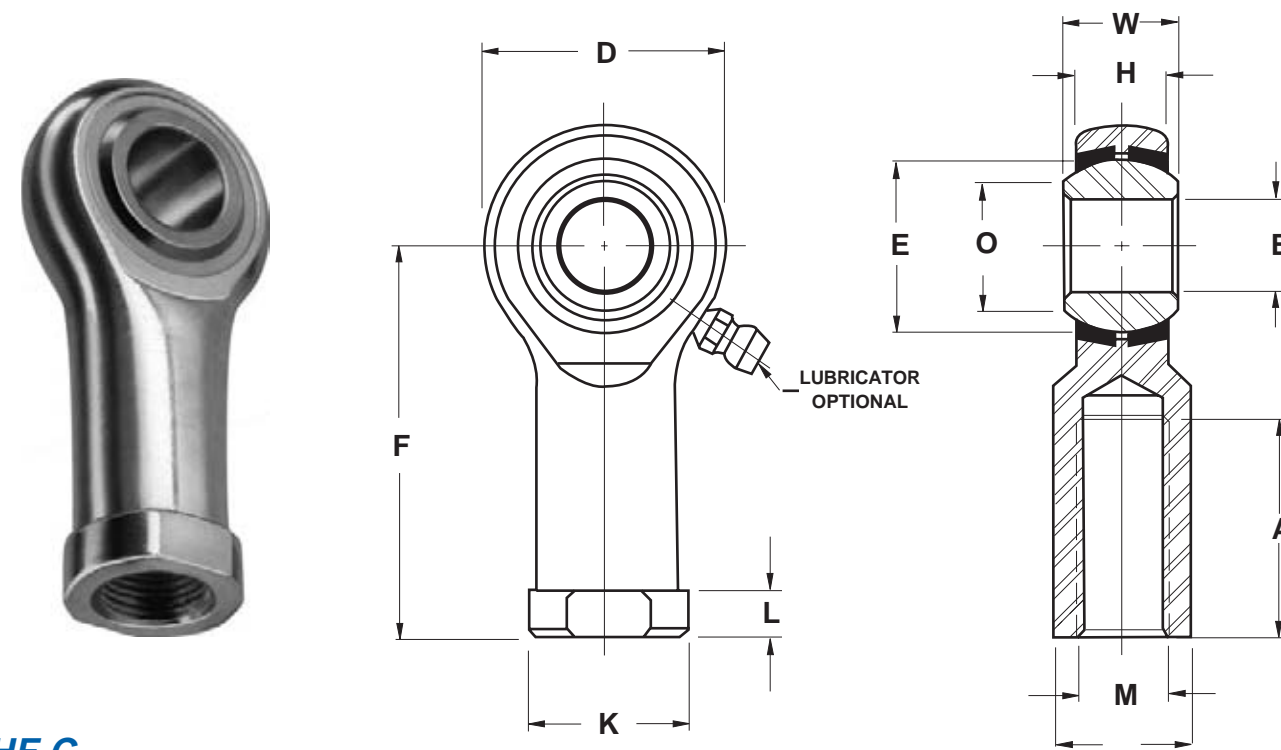

Series HF C

ROD END NUMBER	DIMENSIONS IN INCHES												MAXIMUM STATIC RADIAL LOAD	APPROX WEIGHT
	BORE	BALL WIDTH	HOUSING WIDTH	HEAD DIAMETER	LENGTH TO CENTER OF BALL	THREAD LENGTH	THREAD SIZE	BALL DIAMETER	BALL FLAT DIAMETER	ACROSS WRENCH FLATS	OTHER DIMENSIONS			
	B	W	H	D	F	A	M	E	O	J	K	L		
	+0.0025 -0.0005	+0.005 -0.005	+0.010 -0.010	+0.031 -0.031	+0.031 -0.031	+0.062 -0.062	UNF-3B	REF	REF	+0.010 -0.010	+0.010 -0.010	+0.010 -0.010	LBF	LBS
HF3C	.1900	.312	.250	.625	1.062	.562	.1900-32	.437	.306	.312	.406	.187	1,850	.03
HF4C	.2500	.375	.281	.750	1.312	.750	.2500-28	.515	.353	.375	.468	.187	2,700	.05
HF5C	.3125	.437	.344	.875	1.375	.750	.3125-24	.625	.447	.437	.500	.187	3,350	.08
HF6C	.3750	.500	.406	1.000	1.625	.937	.3750-24	.718	.516	.562	.687	.250	4,450	.12
HF7C	.4375	.562	.437	1.125	1.812	1.062	.4375-20	.812	.586	.625	.750	.250	5,350	.17
HF8C	.5000	.625	.500	1.312	2.125	1.187	.5000-20	.937	.698	.750	.875	.250	7,400	.26
HF10C	.6250	.750	.562	1.500	2.500	1.500	.6250-18	1.125	.839	.875	1.000	.312	8,050	.41
HF12C	.7500	.875	.687	1.750	2.875	1.750	.7500-16	1.312	.978	1.000	1.125	.312	11,300	.64

Outer Member: Carbon steel, with protective coating for corrosion resistance

Ball: 52100 Alloy steel, heat treated, chrome plated

Inserts: Brass

NOTES

- 1 Add letter "L" to prefix to indicate Left Hand thread
Example: HFL4C
- 2 For design options, see page 31
- 3 For Engineering data, see pages 28 thru 30
- 4 "H" tolerance across inserts is +/-0.015

Commercial Extra Capacity Series

Two Piece - Metal-to-Metal

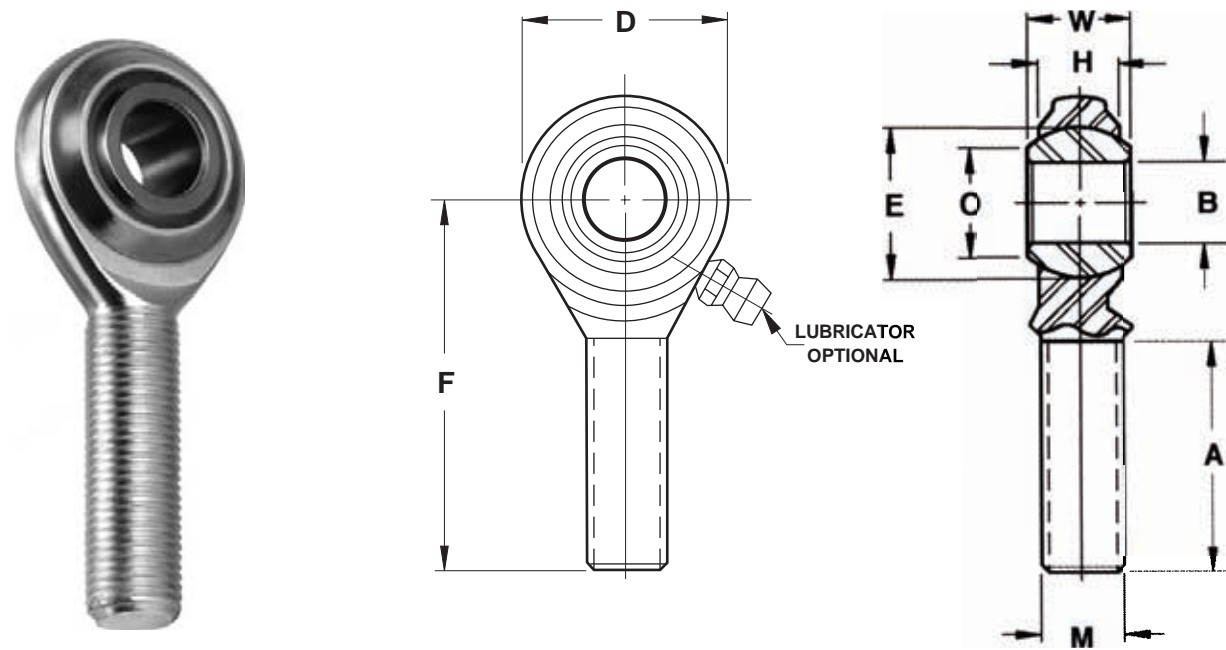

Series M CR

ROD END NUMBER	DIMENSIONS IN INCHES										MAXIMUM STATIC RADIAL LOAD	APPROX WEIGHT
	BORE	BALL WIDTH	HOUSING WIDTH	HEAD DIAMETER	LENGTH TO CENTER OF BALL	THREAD LENGTH	THREAD SIZE	BALL DIAMETER	BALL FLAT DIAMETER			
	B	W	H	D	F	A	M	E	O			
	+0.0025 -0.0005	+0.005 -0.005	+0.010 -0.010	+0.031 -0.031	+0.031 -0.031	+0.062 -0.062	UNF -3A	REF	REF		LBF	LBS
M3CR	.1900	.312	.250	.625	1.250	.750	.1900 - 32	.437	.306		950	.03
M4CR	.2500	.375	.281	.750	1.562	1.000	.2500 - 28	.515	.353		2,000	.05
M5CR	.3125	.437	.344	.875	1.875	1.250	.3125 - 24	.625	.447		3,000	.08
M6CR	.3750	.500	.406	1.000	1.938	1.250	.3750 - 24	.718	.516		5,000	.11
M7CR	.4375	.562	.437	1.125	2.125	1.375	.4375 - 20	.812	.586		6,500	.16
M8CR	.5000	.625	.500	1.312	2.438	1.500	.5000 - 20	.937	.698		9,500	.24
M10CR	.6250	.750	.562	1.500	2.625	1.625	.6250 - 18	1.125	.839		10,000	.40
M12CR	.7500	.875	.687	1.750	2.875	1.750	.7500 - 16	1.312	.978		14,000	.63

Outer Member: Carbon steel, with protective coating for corrosion resistance

Ball: 52100 Alloy steel, heat treated, chrome plated

NOTES

- 1 Add letter "L" to prefix to indicate Left Hand thread
Example: ML4CR
- 2 For design options, see page 31
- 3 For Engineering data, see pages 28 thru 30

Commercial Extra Capacity Series

Two Piece - Metal-to-Metal

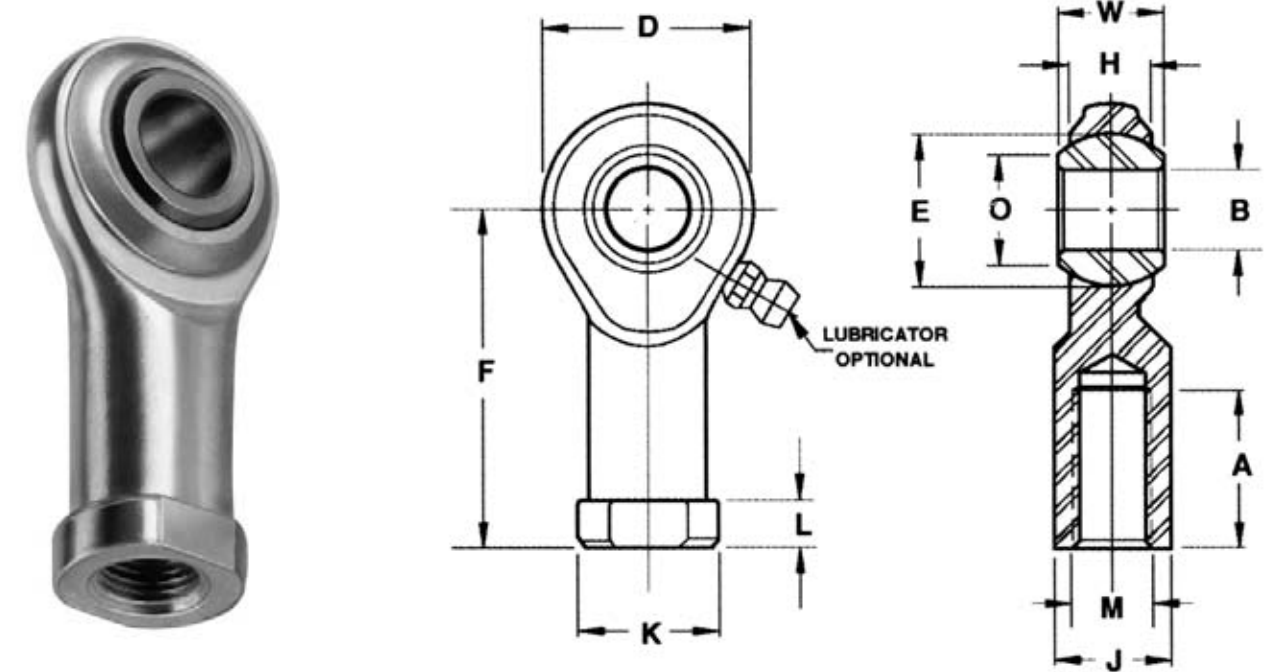

Series F CR

ROD END NUMBER	DIMENSIONS IN INCHES											MAXIMUM STATIC RADIAL LOAD	APPROX WEIGHT	
	BORE	BALL WIDTH	HOUSING WIDTH	HEAD DIAMETER	LENGTH TO CENTER OF BALL	THREAD LENGTH	THREAD SIZE	BALL DIAMETER	BALL FLAT DIAMETER	ACROSS WRENCH FLATS	OTHER DIMENSIONS			
	B	W	H	D	F	A	M	E	O	J	K			L
	+0.0025 -0.0005	+0.005 -0.005	+0.010 -0.010	REF	REF	+0.062 -0.062	UNF-3B	REF	REF	REF	REF	REF	LBF	LBS
F3CR	.1900	.312	.250	.625	1.062	.562	.1900-32	.437	.306	.312	.406	.187	2,000	.03
F4CR	.2500	.375	.281	.750	1.312	.750	.2500-28	.515	.353	.375	.468	.187	3,200	.05
F5CR	.3125	.437	.344	.875	1.375	.750	.3125-24	.625	.447	.437	.500	.187	3,800	.08
F6CR	.3750	.500	.406	1.000	1.625	.937	.3750-24	.718	.516	.562	.687	.250	5,000	.12
F7CR	.4375	.562	.437	1.125	1.812	1.062	.4375-20	.812	.586	.625	.750	.250	6,500	.17
F8CR	.5000	.625	.500	1.312	2.125	1.187	.5000-20	.937	.698	.750	.875	.250	9,500	.26
F10CR	.6250	.750	.562	1.500	2.500	1.500	.6250-18	1.125	.839	.875	1.000	.312	10,000	.41
F12CR	.7500	.875	.687	1.750	2.875	1.750	.7500-16	1.312	.978	1.000	1.125	.312	14,000	.64

Outer Member: Carbon steel, with protective coating for corrosion resistance.

Ball: 52100 Alloy steel, heat treated, chrome plated

NOTES

- 1 Add letter "L" to prefix to indicate Left Hand thread
Example: FL4CR
- 2 For design options, see page 31
- 3 For Engineering data, see pages 28 thru 30



CMHD



CFHD

HEIM "D" Self-Lubricating Series

For commercial applications where a self-lubricating bearing is either desirable or necessary, Heim developed Heim "D" Series bearings. Heim "D" bearings are designed with an engineered thermoplastic race material and offer a lower coefficient of friction than metal-to-metal types that use conventional lubricants. It is a resilient material that performs well under vibratory and dynamic loading and withstands dynamic loads up to 3500 PSI.

Where to Use HEIM "D" Bearings

Heim "D" bearings should be used in applications where the bearing cannot be periodically lubricated or where it is desirable to eliminate the need for regular maintenance. They are also recommended for applications where there is considerable vibration. The resilience of the engineered thermoplastic race

absorbs vibration without causing fretting or galling of the surface. The torque level of the bearing will be low because of the low coefficient of friction of the hardened steel ball on the engineered thermoplastic race. The coefficient of friction for Heim "D" bearings is approximately 0.1, but will vary somewhat depending on the loads, speeds, temperatures, and solvents that are present. The chart on this page shows a typical bearing wear pattern of Heim "D" bearings and how they vary with number of oscillations.

Environmental Characteristics

Heim "D" bearings have good environmental tolerances. They offer advantages over bearings that use a nylon race because the Heim engineered thermoplastic race absorbs very little moisture. It is generally resistant to alcohols, aldehydes, esters, ethers, hydrocarbons, weak acids and bases, water and agricultural chemicals. Dimensional stability is quite good when exposed to these substances, however the Heim engineering department should be contacted for recommendations on specific performance characteristics.

Wear vs. Oscillations

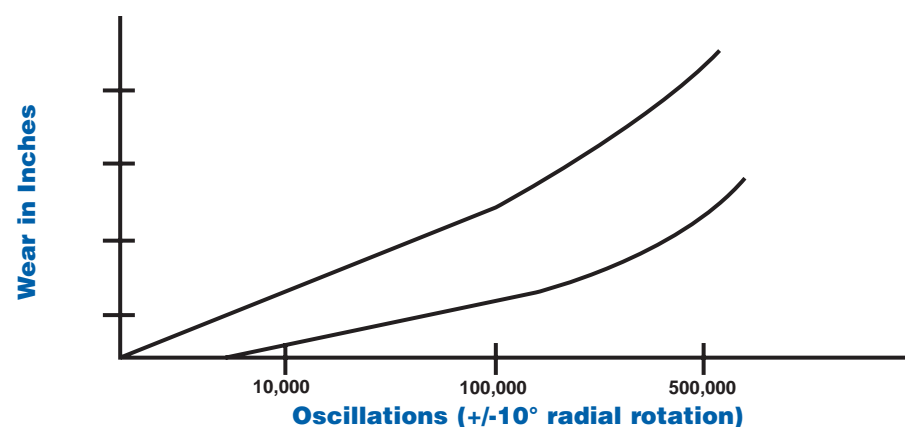

This chart shows typical wear of engineered thermoplastic race bearings (load at one-half static rating - ball surface velocity as noted).

Commercial Series Self-Lubricating

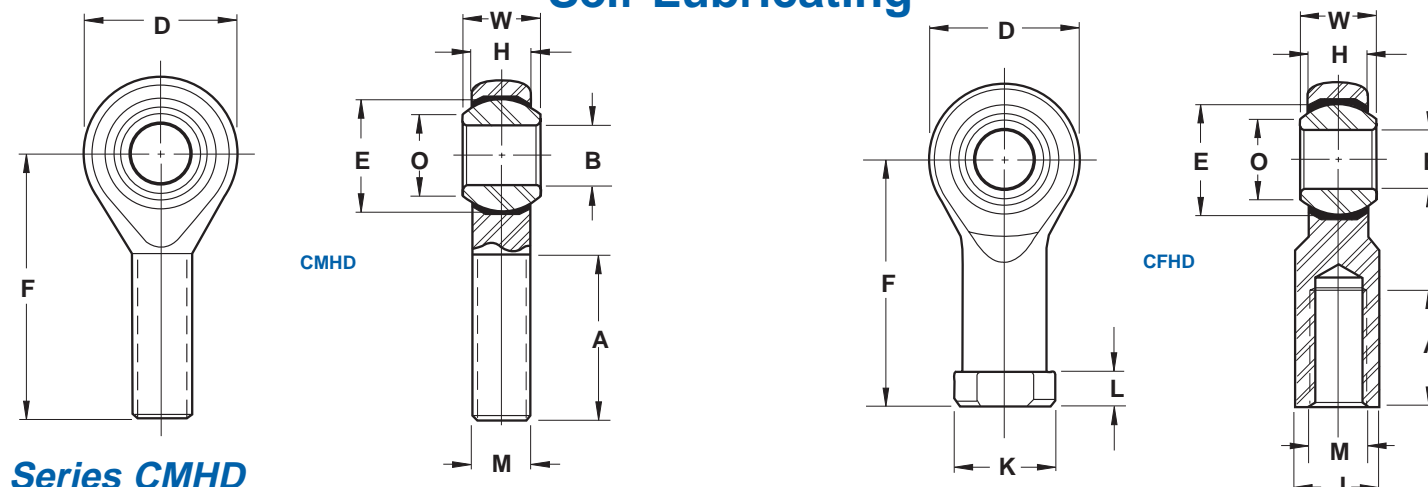

Series CMHD

ROD END NUMBER	DIMENSIONS IN INCHES										MAXIMUM STATIC RADIAL LOAD	APPROX WEIGHT
	BORE	BALL WIDTH	HOUSING WIDTH	HEAD DIAMETER	LENGTH TO CENTER OF BALL	THREAD LENGTH	THREAD SIZE	BALL DIAMETER	BALL FLAT DIAMETER			
	B	W	H	D	F	A	M	E	O			
	+0.0025 -0.0005	+0.005 -0.005	+0.010 -0.010	REF	REF	+0.062 -0.062	UNF-3A	REF	REF		LBF	LBS
CMHD3	.1900	.312	.250	.625	1.250	.750	.1900-32	.437	.306		800	.03
CMHD4	.2500	.375	.281	.750	1.562	1.000	.2500-28	.515	.353		1,060	.05
CMHD5	.3125	.437	.344	.875	1.875	1.250	.3125-24	.625	.447		1,575	.08
CMHD6	.3750	.500	.406	1.000	1.938	1.250	.3750-24	.718	.516		2,150	.12
CMHD7	.4375	.562	.437	1.125	2.125	1.375	.4375-20	.812	.586		2,600	.17
CMHD8	.5000	.625	.500	1.312	2.438	1.500	.5000-20	.937	.698		3,425	.26
CMHD10	.6250	.750	.562	1.500	2.625	1.625	.6250-18	1.125	.839		4,625	.41
CMHD12	.7500	.875	.687	1.750	2.875	1.750	.7500-16	1.312	.978		6,600	.64

Outer Member: Carbon steel, with protective coating for corrosion resistance

Ball: 52100 Alloy steel, heat treated, chrome plated

Race: Engineered thermoplastic

NOTES

- 1 Add letter "L" to prefix to indicate Left Hand thread. Example: CMHDL4
- 2 For design options, see page 31
- 3 For Engineering data, see pages 14, 28 thru 30
- 4 This series is also available with 300 Series Stainless Steel outer member and ball. Part number is CMSD. Contact factory for availability.

Series CFHD

ROD END NUMBER	DIMENSIONS IN INCHES												MAXIMUM STATIC RADIAL LOAD	APPROX WEIGHT
	BORE	BALL WIDTH	HOUSING WIDTH	HEAD DIAMETER	LENGTH TO CENTER OF BALL	THREAD LENGTH	THREAD SIZE	BALL DIAMETER	BALL FLAT DIAMETER	ACROSS WRENCH FLATS	OTHER DIMENSIONS			
	B	W	H	D	F	A	M	E	O	J	K	L		
	+0.0025 -0.0005	+0.005 -0.005	+0.010 -0.010	REF	REF	+0.062 -0.062	UNF-3B	REF	REF	REF	REF	REF	LBF	LBS
CFHD3	.1900	.312	.250	.625	1.062	.562	.1900-32	.437	.306	.312	.406	.187	800	.03
CFHD4	.2500	.375	.281	.750	1.312	.750	.2500-28	.515	.355	.375	.468	.187	1,060	.05
CFHD5	.3125	.437	.344	.875	1.375	.750	.3125-24	.625	.447	.437	.500	.187	1,575	.08
CFHD6	.3750	.500	.406	1.000	1.625	.937	.3750-24	.718	.517	.562	.687	.250	2,150	.12
CFHD7	.4375	.562	.437	1.125	1.812	1.062	.4375-20	.812	.586	.625	.750	.250	2,600	.17
CFHD8	.5000	.625	.500	1.312	2.125	1.187	.5000-20	.937	.698	.750	.875	.250	3,425	.26
CFHD10	.6250	.750	.562	1.500	2.500	1.500	.6250-18	1.125	.839	.875	1.000	.312	4,625	.41
CFHD12	.7500	.875	.687	1.750	2.875	1.750	.7500-16	1.312	.978	1.000	1.125	.312	6,600	.64

Outer Member: Carbon steel, with protective coating for corrosion resistance

Ball: 52100 Alloy steel, heat treated, chrome plated

Race: Engineered thermoplastic

NOTES

- 1 Add letter "L" to prefix to indicate Left Hand thread. Example: CFHDL4
- 2 For design options, see page 31
- 3 For Engineering data, see pages 14, 28 thru 30
- 4 This series is also available with 300 Series Stainless Steel outer member and ball. Part number is CFSD. Contact factory for availability.

Precision Aircraft Series

Four Piece - Metal-to-Metal

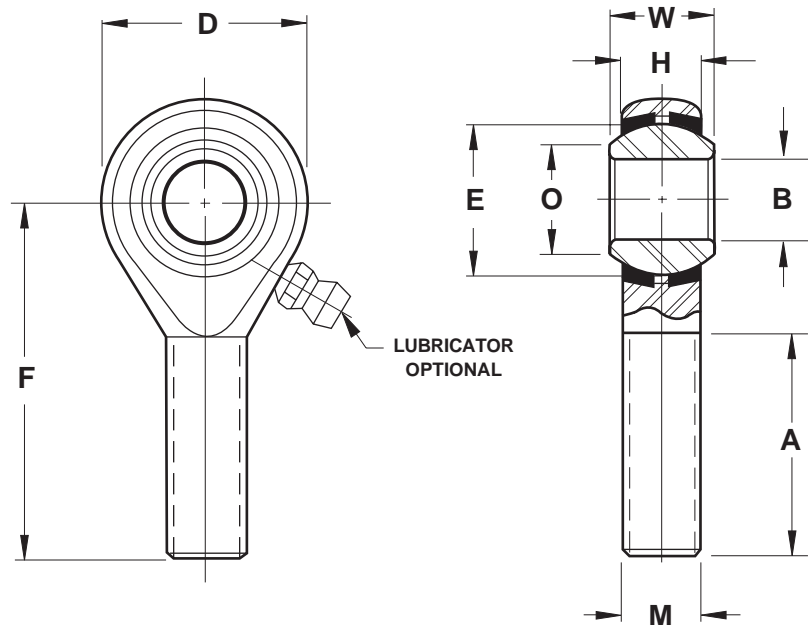

Precision Aircraft Series

Four Piece - Metal-to-Metal

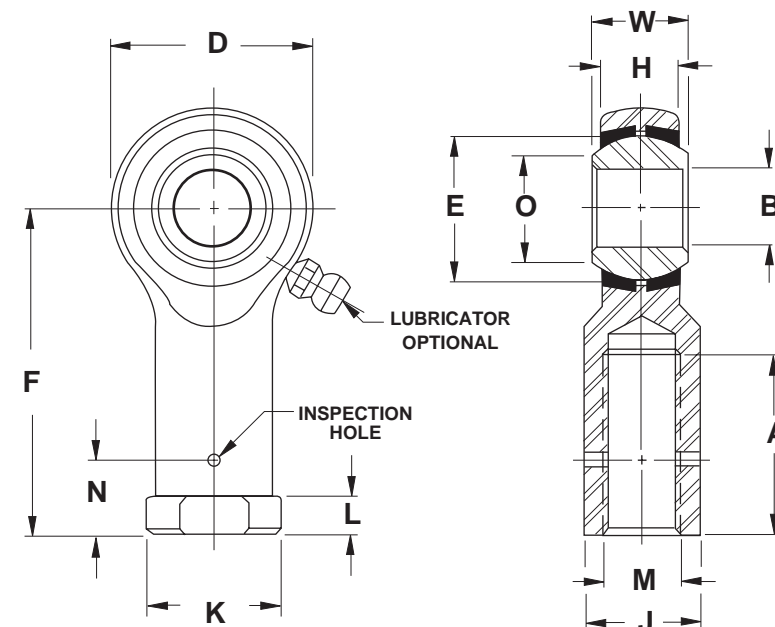

Series HM M

ROD END NUMBER	DIMENSIONS IN INCHES										MAXIMUM STATIC RADIAL LOAD ⁷	APPROX WEIGHT
	BORE	BALL WIDTH	HOUSING WIDTH	HEAD DIAMETER	LENGTH TO CENTER OF BALL	THREAD LENGTH	THREAD SIZE	BALL DIAMETER	BALL FLAT DIAMETER			
	B	W	H	D	F	A	M	E	O			
	+0.015 -0.005	+0.000 -0.005	+0.005 -0.005	+0.010 -0.010	+0.031 -0.031	+0.062 -0.031	CLASS -3A	REF	REF		LBF	LBS
HM2M	.1250	.250	.187	.469	.937	.500	.1380-32UNC	.312	.187		450	.02
HM2AM	.1562	.281	.219	.562	1.125	.625	.1640-32UNC	.375	.248		650	.02
HM3M	.1900	.312	.250	.625	1.250	.750	.1900-32UNF	.437	.306		900	.03
HM4M	.2500	.375	.281	.750	1.562	1.000	.2500-28UNF	.515	.353		1,700	.05
HM5M	.3125	.437	.344	.875	1.875	1.250	.3125-24UNF	.625	.447		2,500	.08
HM6M	.3750	.500	.406	1.000	1.938	1.250	.3750-24UNF	.718	.516		4,000	.12
HM7M	.4375	.562	.437	1.125	2.125	1.375	.4375-20UNF	.812	.586		5,000	.17
HM8M	.5000	.625	.500	1.312	2.438	1.500	.5000-20UNF	.937	.698		7,000	.26
HM10M	.6250	.750	.562	1.500	2.625	1.625	.6250-18UNF	1.125	.839		8,050	.41
HM12M	.7500	.875	.687	1.750	2.875	1.750	.7500-16UNF	1.312	.978		11,300	.64
HM16M ⁶	1.0000	1.375	1.000 ⁵	2.750 ⁵	4.125	2.125	1.2500-12UNF	1.875	1.275		28,400	2.25

Outer Member: Aircraft quality carbon steel, magnetic particle inspected, with protective coating for corrosion resistance

Ball: 52100 Alloy steel, heat treated, chrome plated

Inserts: Brass

NOTES

- Add letter "L" to prefix to indicate Left Hand thread
Example: HML4M
- For design options, see page 31
- For Engineering data, see pages 28 thru 30
- "H" tolerance across inserts is +/-0.015
- Tolerances for 16 size: "D" +0.030
-.010
"H" +0.030
-.010
- Outer Member:** Alloy steel
Inserts: One piece carbon steel race
- Load ratings reflect loads without lubricator.
For loads with lubricator contact Heim Engineering.

Series HF M

ROD END NUMBER	DIMENSIONS IN INCHES														MAXIMUM STATIC RADIAL LOAD	APPROX WEIGHT
	BORE	BALL WIDTH	HOUSING WIDTH	HEAD DIAMETER	LENGTH TO CENTER OF BALL	THREAD LENGTH	THREAD SIZE	BALL DIAMETER	BALL FLAT DIAMETER	ACROSS WRENCH FLATS	OTHER DIMENSIONS					
	B	W	H	D	F	A	M	E	O	J	K	N	L	LBF		
	+0.015 -0.005	+0.000 -0.005	+0.005 -0.005	+0.010 -0.010	+0.031 -0.031	+0.062 -0.031	CLASS -3B	REF	REF	+0.010 -0.010	+0.010 -0.010	+0.020 -0.020	+0.010 -0.010	LBF	LBS	
HF2M	.1250	.250	.187	.469	.812	.375	.1380-32UNC	.312	.187	.250	.312	.250	.187	1,200	.02	
HF2AM	.1562	.281	.219	.562	.875	.375	.1640-32UNC	.375	.248	.281	.344	.250	.187	1,700	.02	
HF3M	.1900	.312	.250	.625	1.062	.562	.1900-32UNF	.437	.306	.312	.406	.312	.187	1,850	.03	
HF4M	.2500	.375	.281	.750	1.312	.750	.2500-28UNF	.515	.353	.375	.468	.312	.187	2,700	.05	
HF5M	.3125	.437	.344	.875	1.375	.750	.3125-24UNF	.625	.447	.437	.500	.406	.187	3,350	.08	
HF6M	.3750	.500	.406	1.000	1.625	.937	.3750-24UNF	.718	.516	.562	.687	.469	.250	4,450	.12	
HF7M	.4375	.562	.437	1.125	1.812	1.062	.4375-20UNF	.812	.586	.625	.750	.531	.250	5,350	.17	
HF8M	.5000	.625	.500	1.312	2.125	1.187	.5000-20UNF	.937	.698	.750	.875	.594	.250	7,400	.26	
HF10M	.6250	.750	.562	1.500	2.500	1.500	.6250-18UNF	1.125	.839	.875	1.000	.750	.312	8,050	.41	
HF12M	.7500	.875	.687	1.750	2.875	1.750	.7500-16UNF	1.312	.978	1.000	1.125	.875	.312	11,300	.64	
HF16M ⁶	1.0000	1.375	1.000 ⁵	2.750 ⁵	4.125	2.125	1.2500-12UNF	1.875	1.275	1.500 ⁵	1.625 ⁵	1.000	.437 ⁵	28,400	2.25	

Outer Member: Aircraft quality carbon steel, magnetic particle inspected, with protective coating for corrosion resistance

Ball: 52100 Alloy steel, heat treated, chrome plated

Inserts: Brass

NOTES

- Add letter "L" to prefix to indicate Left Hand thread
Example: HFL4M
- For design options, see page 31
- For Engineering data, see pages 28 thru 30
- "H" tolerance across inserts is +/-0.015
- Tolerances for 16 size: "D" +0.030
-.010
"H" +0.030
-.010
"K", "J", "L" +/-0.015
- Outer Member:** Alloy steel
Inserts: One piece carbon steel race
- Load ratings reflect loads without lubricator.
For loads with lubricator contact Heim Engineering.

Precision Special Purpose Aircraft Series

Four Piece - Metal-to-Metal

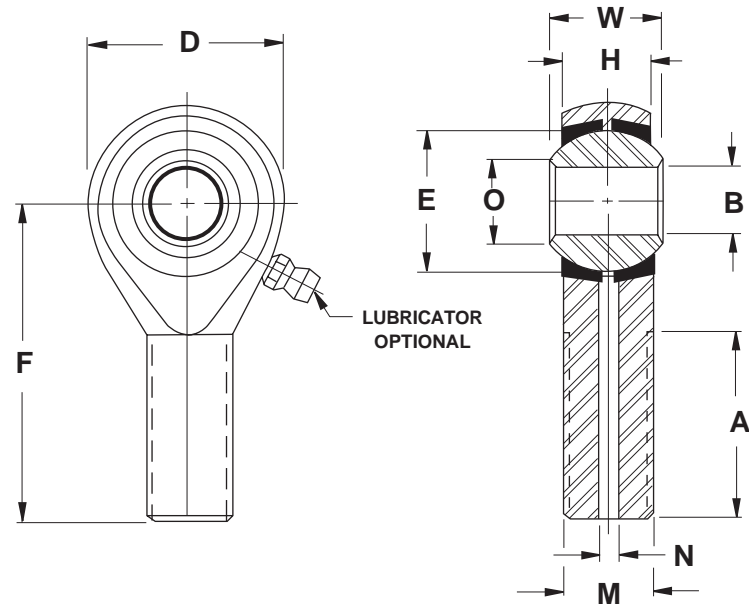

Series M M

ROD END NUMBER	DIMENSIONS IN INCHES										MAXIMUM STATIC RADIAL LOAD	APPROX WEIGHT
	BORE	BALL WIDTH	HOUSING WIDTH	HEAD DIAMETER	LENGTH TO CENTER OF BALL	THREAD LENGTH	THREAD SIZE	BALL DIAMETER	BALL FLAT DIAMETER	DRILL DIAMETER		
	B	W	H	D	F	A	M	E	O	N		
	+0.0015 -.0005	+0.000 -.005	+0.005 -.005	+0.010 -.010	+0.031 -.031	+0.062 -.031	UNF -3A	REF	REF	REF	LBF	LBS
M3414M	.1900	.437	.328	.750	1.560	1.000	.2500-28	.515	.273	-	1,700	.05
MD3514M	.1900	.437	.328	.875	1.375	.750	.3125-24	.515	.273	.113	2,150	.07
MD3614M	.1900	.437	.328	.750	1.375	.750	.3750-24	.515	.273	.113	2,850	.07
MD3616M	.1900	.500	.375	.812	1.812	1.062	.3750-24	.593	.321	.136	2,750	.08
M4414M	.2500	.437	.304	.812	1.562	1.000	.2500-28	.562	.354	-	1,700	.06
MD4615M	.2500	.484	.335	.875	2.312	1.500	.3750-24	.625	.395	.136	3,150	.10
MD4616M	.2500	.500	.335	.875	2.062	1.500	.3750-24	.625	.375	.159	2,750	.09

Outer Member: Aircraft quality carbon steel, magnetic particle inspected, with protective coating for corrosion resistance

Ball: 52100 Alloy steel, heat treated, chrome plated

Inserts: Brass

NOTES

- 1 Add letter "L" to prefix to indicate Left Hand thread
Example: ML3414M
- 2 For design options, see page 31
- 3 For Engineering data, see pages 28 thru 30
- 4 "H" tolerance across inserts is +/-0.015

Precision Special Purpose Aircraft Series

Four Piece - Metal-to-Metal

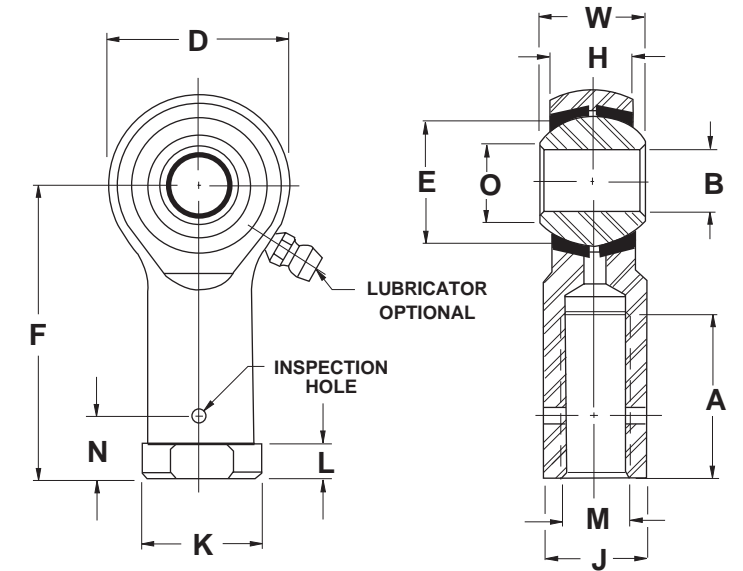

Series F M

ROD END NUMBER	DIMENSIONS IN INCHES												MAXIMUM STATIC RADIAL LOAD	APPROX WEIGHT	
	BORE	BALL WIDTH	HOUSING WIDTH	HEAD DIAMETER	LENGTH TO CENTER OF BALL	THREAD LENGTH	THREAD SIZE	BALL DIAMETER	BALL FLAT DIAMETER	ACROSS WRENCH FLATS	OTHER DIMENSIONS				
	B	W	H	D	F	A	M	E	O	J	K	N			L
	+0.0015 -.0005	+0.000 -.005	+0.005 -.005	+0.010 -.010	+0.031 -.031	+0.062 -.031	UNF -3B	REF	REF	+0.010 -.010	+0.010 -.010	+0.020 -.020	+0.010 -.010	LBF	LBS
F3414M	.1900	.437	.328	.750	1.375	.750	.2500-28	.515	.273	.375	.468	.312	.187	2,850	.06
F34714M	.1900	.437	.328	.750	1.062	.437	.2500-28	.515	.273	.375	.375	-	-	2,850	.05
F3416M	.1900	.500	.375	.812	1.375	.750	.2500-28	.593	.321	.375	.468	.312	.187	2,750	.08
F3514M	.1900	.437	.328	.750	1.375	.750	.3125-24	.515	.273	.438	.500	.406	.187	2,850	.07
F4414M	.2500	.437	.304	.812	1.375	.750	.2500-28	.562	.354	.375	.468	.312	.187	2,950	.07
F4519M	.2500	.593	.438	.938	1.469	.750	.3125-24	.687	.347	.438	.500	.406	.187	3,700	.11

Outer Member: Aircraft quality carbon steel, magnetic particle inspected, with protective coating for corrosion resistance

Ball: 52100 Alloy steel, heat treated, chrome plated

Inserts: Brass

NOTES

- 1 Add letter "L" to prefix to indicate Left Hand thread
Example: FL3414M
- 2 For design options, see page 31
- 3 For Engineering data, see pages 28 thru 30
- 4 "H" tolerance across inserts is +/-0.015

Precision Aircraft Series

Self-Lubricating

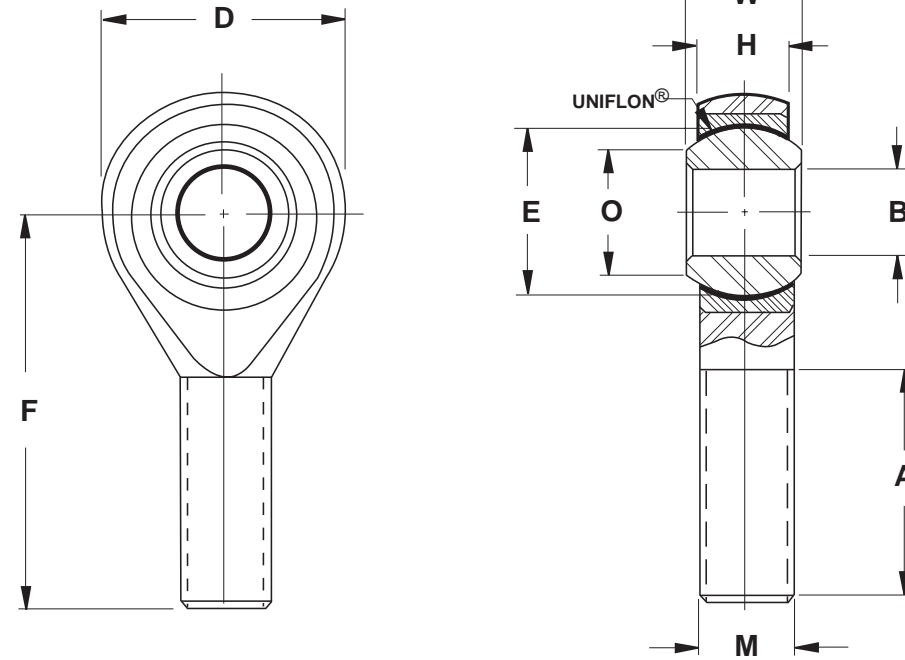

Series HME M

ROD END NUMBER	DIMENSIONS IN INCHES										MAXIMUM STATIC RADIAL LOAD	APPROX WEIGHT
	BORE	BALL WIDTH	HOUSING WIDTH	HEAD DIAMETER	LENGTH TO CENTER OF BALL	THREAD LENGTH	THREAD SIZE	BALL DIAMETER	BALL FLAT DIAMETER			
	B	W	H	D	F	A	M	E	O			
	+0.015 -0.005	+0.000 -0.005	+0.005 -0.005	+0.010 -0.010	+0.010 -0.010	+0.062 -0.031	UNF-3A	REF	REF		LBF	LBS
HME3M	.1900	.312	.250	.625	1.250	.750	.1900-32	.437	.306		865	.03
HME4M	.2500	.375	.281	.750	1.562	1.000	.2500-28	.515	.353		1,550	.05
HME5M	.3125	.437	.344	.875	1.875	1.250	.3125-24	.625	.447		2,080	.08
HME6M	.3750	.500	.406	1.000	1.938	1.250	.3750-24	.718	.516		2,950	.12
HME7M	.4375	.562	.437	1.125	2.125	1.375	.4375-20	.812	.586		3,160	.17
HME8M	.5000	.625	.500	1.312	2.438	1.500	.5000-20	.937	.698		4,925	.26
HME10M	.6250	.750	.562	1.500	2.625	1.625	.6250-18	1.125	.839		5,465	.41
HME12M	.7500	.875	.687	1.750	2.875	1.750	.7500-16	1.312	.978		8,300	.64
HME16M	1.0000	1.375	1.000	2.750	4.125	2.125	1.2500-12	1.875	1.275		28,400	2.25

Outer Member: Aircraft quality carbon steel, magnetic particle inspected, with protective coating for corrosion resistance

Ball: 52100 Alloy steel, heat treated, chrome plated

Race: Aluminum

Liner: Self-lubricating UNIFLON®

NOTES

- ① Add letter "L" to prefix to indicate Left Hand thread
Example: HMLE4M
- ② For design options, see page 31
- ③ For Engineering data, see pages 28 thru 30, 54
- ④ Tolerances for 16 size: "D" +.030
-.010
"H" +.030
-.010

Precision Aircraft Series

Self-Lubricating

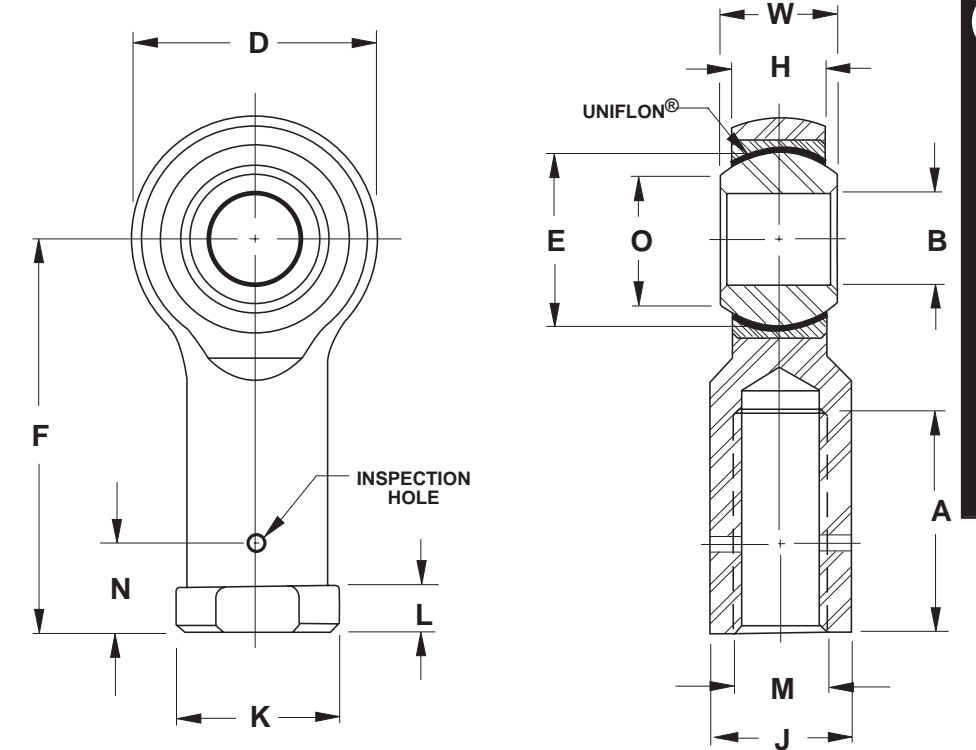

Series HFE M

ROD END NUMBER	DIMENSIONS IN INCHES													MAXIMUM STATIC RADIAL LOAD	APPROX WEIGHT	
	BORE	BALL WIDTH	HOUSING WIDTH	HEAD DIAMETER	LENGTH TO CENTER OF BALL	THREAD LENGTH	THREAD SIZE	BALL DIAMETER	BALL FLAT DIAMETER	ACROSS WRENCH FLATS	OTHER DIMENSIONS					
	B	W	H	D	F	A	M	E	O	J	K	N	L			
	+0.015 -0.005	+0.000 -0.005	+0.005 -0.005	+0.010 -0.010	+0.010 -0.010	+0.062 -0.031	UNF-3B	REF	REF	+0.010 -0.010	+0.010 -0.010	+0.020 -0.020	+0.010 -0.010		LBF	LBS
HFE3M	.1900	.312	.250	.625	1.062	.562	.1900-32	.437	.306	.312	.406	.312	.187		865	.03
HFE4M	.2500	.375	.281	.750	1.312	.750	.2500-28	.515	.353	.375	.468	.312	.187		1,550	.05
HFE5M	.3125	.437	.344	.875	1.375	.750	.3125-24	.625	.447	.437	.500	.406	.187		2,080	.08
HFE6M	.3750	.500	.406	1.000	1.625	.937	.3750-24	.718	.516	.562	.687	.469	.250		2,950	.12
HFE7M	.4375	.562	.437	1.125	1.812	1.062	.4375-20	.812	.586	.625	.750	.531	.250		3,160	.17
HFE8M	.5000	.625	.500	1.312	2.125	1.187	.5000-20	.937	.698	.750	.875	.594	.250		4,925	.26
HFE10M	.6250	.750	.562	1.500	2.500	1.500	.6250-18	1.125	.839	.875	1.000	.750	.312		5,465	.41
HFE12M	.7500	.875	.687	1.750	2.875	1.750	.7500-16	1.312	.978	1.000	1.125	.875	.312		8,300	.64
HFE16M	1.0000	1.375	1.000	2.750	4.125	2.125	1.2500-12	1.875	1.275	1.500	1.625	1.000	.437		28,400	2.25

Outer Member: Aircraft quality carbon steel, magnetic particle inspected, with protective coating for corrosion resistance

Ball: 52100 Alloy steel, heat treated, chrome plated

Race: Aluminum

Liner: Self-lubricating UNIFLON®

NOTES

- ① Add letter "L" to prefix to indicate Left Hand thread
Example: HFLE4M
- ② For design options, see page 31
- ③ For Engineering data, see pages 28 thru 30, 54
- ④ Tolerances for 16 size: "D" +.030
-.010
"H" +.030
-.010
"K", "J", "L" +.015
-.015

Military Series

(M81935/1)

Self-Lubricating



ROD ENDS

Military Series

(M81935/1)

Self-Lubricating

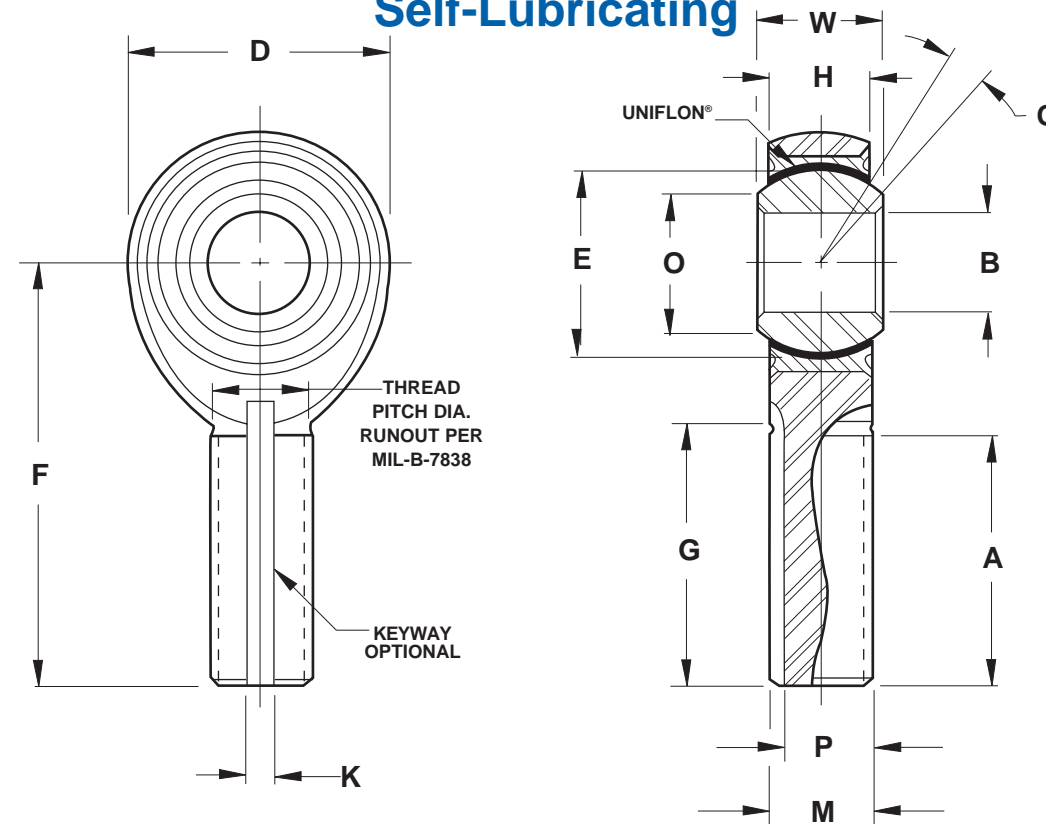

ROD ENDS

Series ME

HEIM PART NUMBER	M81935/1 DASH NO	DIMENSIONS IN INCHES														MISALIGNMENT ANGLE	ULTIMATE STATIC RADIAL LOAD	FATIGUE LOAD	AXIAL PROOF LOAD	APPROX WEIGHT	NO LOAD ROTATIONAL BREAKAWAY TORQUE	
		BORE	BALL WIDTH	HOUSING WIDTH	HEAD DIAMETER	LENGTH TO CENTER OF BALL	THREAD LENGTH	THREAD SIZE	BALL DIAMETER	BALL FLAT DIAMETER	KEYWAY		KEYWAY FLAT	MIN	MAX							
		B	W	H	D	F	A	M	E	O	K	P	G	Q								
		+0.0000 - .0005	+0.000 - .002	+0.005 - .005	+0.010 - .010	+0.010 - .010	+0.031 - .031	UNJF-3A	REF	MIN		+0.005 - .000	+0.000 - .005	+0.000 - .020	MIN	LBF	LBF	LBF	LBS	MIN	MAX	
ME3	3	.1900	.437	.337	.806	1.562	.968	.3125-24	.531	.300		.062	.268	.980	15	2,360	1,470	1,000	.072	0.5	6	
ME4	4	.2500	.437	.337	.806	1.562	.968	.3125-24	.531	.300		.062	.268	.980	15	4,860	2,380	1,000	.072	0.5	6	
ME5	5	.3125	.437	.327	.900	1.875	1.187	.3125-24	.593	.360		.062	.268	1.270	14	7,180	2,770	1,100	.087	1	15	
ME6	6	.3750	.500	.416	1.025	1.938	1.187	.3750-24	.687	.470		.093	.319	1.235	8	8,550	3,570	1,660	.136	1	15	
ME7	7	.4375	.562	.452	1.150	2.125	1.281	.4375-20	.781	.540		.093	.383	1.402	10	12,000	4,800	1,850	.183	1	15	
ME8	8	.5000	.625	.515	1.337	2.438	1.468	.5000-20	.875	.610		.093	.445	1.589	9	19,500	7,680	2,040	.278	1	15	
ME10	10	.6250	.750	.577	1.525	2.625	1.562	.6250-18	1.062	.750		.125	.541	1.683	12	21,900	9,180	2,430	.424	1	15	
ME12	12	.7500	.875	.640	1.775	2.875	1.687	.7500-16	1.250	.850		.125	.663	1.808	13	29,300	11,600	2,810	.639	1	15	
ME14	14	.8750	.875	.765	2.025	3.375	2.000	.8750-14	1.375	1.000		.156	.777	2.121	6	34,500	13,100	3,320	.963	1	24	
ME16	16	1.0000	1.375	1.015	2.775	4.125	2.343	1.2500-12	1.875	1.270		.187	1.136	2.464	12	80,300	30,400	4,340	2.546	1	24	

Outer Member: 4340 Alloy steel, heat treated, magnetic particle inspected, cadmium plated and chromate treated

Ball: 440C heat treated

Race: 17-4PH heat treated

Liner: Self-lubricating "E" UNIFLON® per SAE-AS81820 (formerly MIL-B-81820)

NOTES

- 1 Add letter "L" to prefix to indicate Left Hand thread.
Example: MEL4
- 2 Add letter "K" to prefix to indicate Keyway
Example: MEK4
- 3 For liner specification, see page 54
- 4 HEIM is qualified to supply this part and all variations per SAE-AS81935
(formerly MIL-B-81935)
- 5 Based on bolt bending fatigue strength 180,000 PSI
- 6 Shank limitation

Military Series

(M81935/2)

Self-Lubricating



Military Series

(M81935/2)

Self-Lubricating

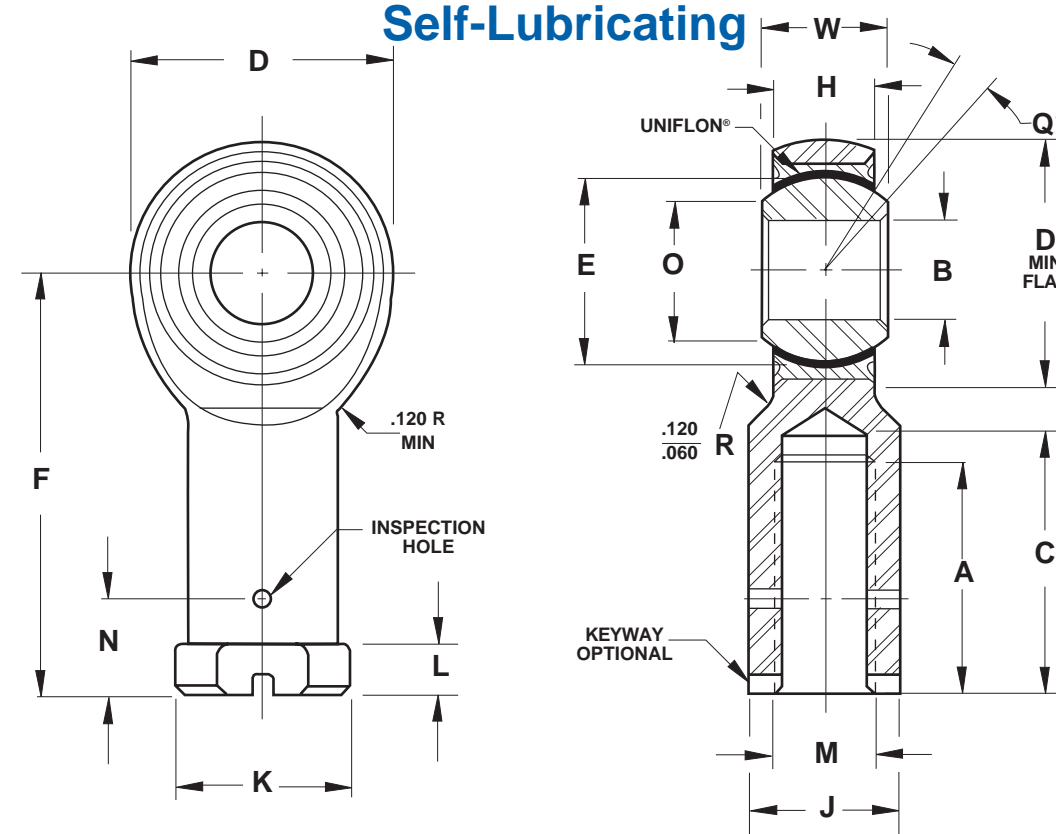

Series FE

HEIM PART NUMBER	M81935/2 DASH NO	DIMENSIONS IN INCHES															ACROSS WRENCH FLATS	MISALIGNMENT ANGLE	ULTIMATE STATIC RADIAL LOAD	FATIGUE LOAD	AXIAL PROOF LOAD	APPROX WEIGHT	NO LOAD ROTATIONAL BREAKAWAY TORQUE	
		BORE	BALL WIDTH	HOUSING WIDTH	HEAD DIAMETER	LENGTH TO CENTER OF BALL	THREAD LENGTH	THREAD SIZE	BALL DIAMETER	BALL FLAT DIAMETER	OTHER DIMENSIONS				MIN	MAX								
		B	W	H	D	F	A	M	E	O	K	N	L	C									J	Q
		+0.000 -0.0005	+0.000 -0.002	+0.005 -0.005	+0.010 -0.010	+0.010 -0.010	+0.031 -0.031	UNJF-3B	REF	MIN						+0.002 -0.010	MIN	LBF	LBF	LBF	LBS	MIN	MAX	
FE3	3	.1900	.437	.337	.806	1.375	.750	.3125-24	.531	.300						.437	15	2,360	1,470 ⁵	1,000	.080	0.5	6	
FE4	4	.2500	.437	.337	.806	1.469	.750	.3125-24	.531	.300						.437	15	4,860	2,380	1,000	.084	0.5	6	
FE5	5	.3125	.437	.327	.900	1.625	.875	.3750-24	.593	.360						.500	14	7,180	3,020	1,100	.102	1	15	
FE6	6	.3750	.500	.416	1.025	1.812	1.000	.3750-24	.687	.470						.562	8	8,550	3,570	1,660	.161	1	15	
FE7	7	.4375	.562	.452	1.150	2.000	1.125	.4375-20	.781	.540						.625	10	12,000	4,800	1,850	.212	1	15	
FE8	8	.5000	.625	.515	1.337	2.250	1.250	.5000-20	.875	.610						.750	9	19,500	8,260	2,040	.325	1	15	
FE10	10	.6250	.750	.577	1.525	2.500	1.375	.6250-18	1.062	.750						.875	12	21,900	9,180	2,430	.481	1	15	
FE12	12	.7500	.875	.640	1.775	2.875	1.625	.7500-16	1.250	.850						1.000	13	29,300	11,600	2,810	.673	1	15	
FE14	14	.8750	.875	.765	2.025	3.375	1.875	.8750-14	1.375	1.000						1.125	6	34,500	13,100	3,320	.959	1	24	
FE16	16	1.0000	1.375	1.015	2.775	4.125	2.125	1.2500-12	1.875	1.270						1.750	12	80,300	30,400	4,340	2.717	1	24	

Outer Member: 4340 Alloy steel, heat treated, magnetic particle inspected, cadmium plated and chromate treated

Ball: 440C heat treated

Race: 17-4PH heat treated

Liner: Self-lubricating "E" UNIFLON® per SAE-AS81820 (formerly MIL-B-81820)

NOTES

- Add letter "L" to prefix to indicate Left Hand thread
Example: FEL4
- Add letter "K" to prefix to indicate Keyway
Example: FEK4
- For liner specification, see page 54
- HEIM is qualified to supply this part and all variations per SAE-AS81935 (formerly MIL-B-81935)
- Based on bolt bending fatigue strength 180,000 PSI

Metric Precision Series

Four Piece - Metal-to-Metal

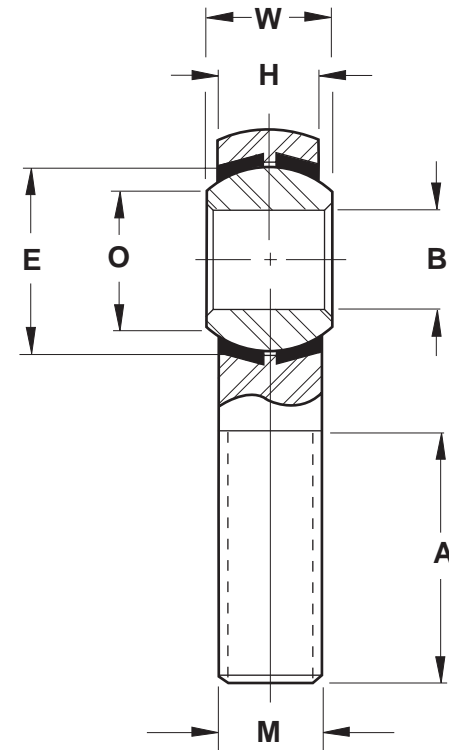
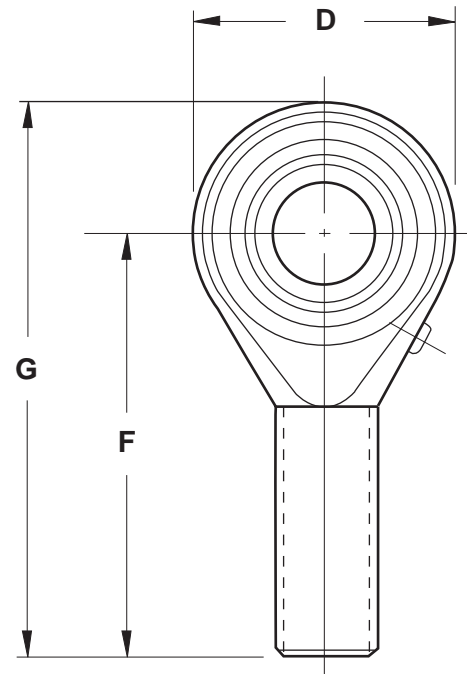

Metric Precision Series

Four Piece - Metal-to-Metal

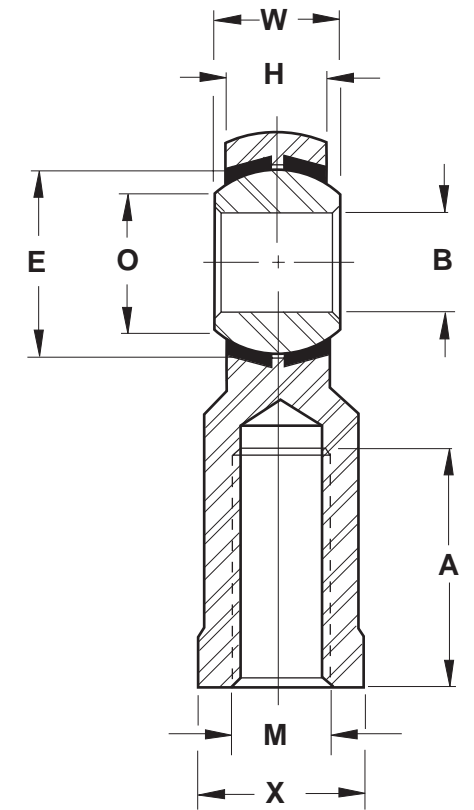
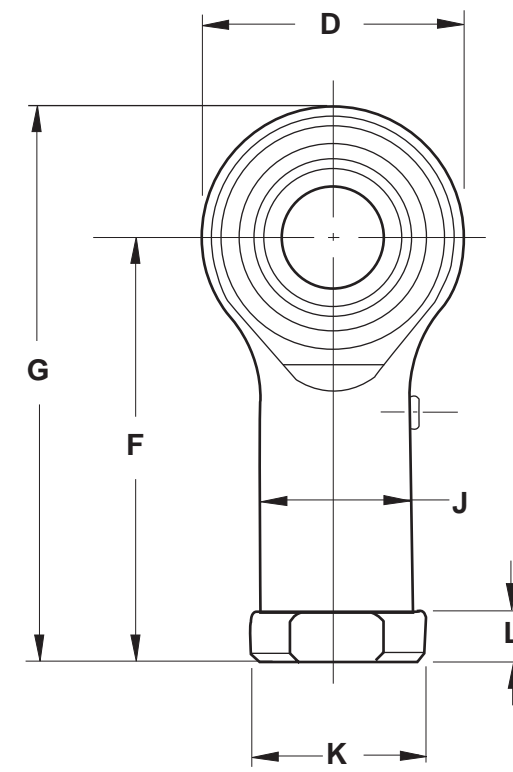

Series SM, SMG

ROD END NUMBER	DIMENSIONS IN MILLIMETERS										MAXIMUM STATIC RADIAL LOAD	APPROX WEIGHT
	BORE	BALL WIDTH	HOUSING WIDTH	HEAD DIAMETER	LENGTH TO CENTER OF BALL	OVERALL LENGTH	THREAD LENGTH	THREAD SIZE	BALL DIAMETER	BALL FLAT DIAMETER		
	B	W	H	D	F	G	A	M	E	O		
	H7	+0.127 -0.127	+0.254 -0.254	+0.787 -0.787	+0.787 -0.787	+0.787 -0.787	+1.575 -1.575		REF	REF	daN	g
SM5	5	8	6	16	33	35	20	M5 x 0,8	11.11	7.71	340	12
SM6	6	9	6.75	18	36	39	22	M6 x 1	12.70	8.96	490	18
SM8	8	12	9	22	42	47	25	M8 x 1,25	15.88	10.40	830	35
SMG10	10	14	10.50	26	48	56	29	M10 x 1,5	19.05	12.92	1,270	57
SMG12	12	16	12	30	54	65	33	M12 x 1,75	22.23	15.43	1,670	87
SMG14	14	19	13.50	34	60	74	36	M14 x 2	25.40	16.86	2,060	120
SMG16	16	21	15	38	66	83	40	M16 x 2	28.58	19.39	2,500	170
SMG18	18	23	16.50	42	72	92	44	M18 x 1,5	31.75	21.89	2,940	240
SMG20	20	25	18	46	78	100	47	M20 x 1,5	34.92	24.38	3,430	320
SMG22	22	28	20	50	84	109	51	M22 x 1,5	38.10	25.84	4,120	420
SMG25	25	31	22	56	94	122	57	M24 x 2	42.85	29.60	5,000	580

Outer Member: Carbon steel, with protective coating for corrosion resistance

Ball: Chrome steel, heat treated

Inserts: Brass

NOTES

- ① Add letter "L" to prefix to indicate Left Hand thread
Example: SML8
- ② Also available: extra capacity, stainless steel, PTFE liner, chrome-plated ball, reduced play. Consult factory for information.
- ③ Letter "G" indicates lubricator (SMG10 to SMG25)

Series SF, SFG

ROD END NUMBER	DIMENSIONS IN MILLIMETERS													MAXIMUM STATIC RADIAL LOAD	APPROX WEIGHT	
	BORE	BALL WIDTH	HOUSING WIDTH	HEAD DIAMETER	LENGTH TO CENTER OF BALL	OVERALL LENGTH	THREAD LENGTH	THREAD SIZE	BALL DIAMETER	BALL FLAT DIAMETER	ACROSS WRENCH FLATS	OTHER DIMENSIONS				
	B	W	H	D	F	G	A	M	E	O	J	X	K			L
	H7	+0.127 -0.127	+0.254 -0.254	+0.787 -0.787	+0.787 -0.787	+0.787 -0.787	+1.575 -1.575		REF	REF	+0.254 -0.254	+0.254 -0.254	+0.254 -0.254	+0.254 -0.254	daN	g
SF5	5	8	6	16	27	35	14	M5 x 0,8	11.11	7.71	7.50	8	9.50	4	560	14
SF6	6	9	6.75	18	30	39	14	M6 x 1	12.70	8.96	9.50	10	12	5	690	22
SF8	8	12	9	22	36	47	17	M8 x 1,25	15.88	10.40	12.50	13	16	5	980	38
SFG10	10	14	10.50	26	43	56	20	M10 x 1,5	19.05	12.92	15	16	19	6.50	1,320	70
SFG12	12	16	12	30	50	65	22	M12 x 1,75	22.23	15.43	17.50	18	22	6.50	1,670	110
SFG14	14	19	13.50	34	57	74	27	M14 x 2	25.40	16.86	20	21	25	8	2,060	150
SFG16	16	21	15	38	64	83	33	M16 x 2	28.58	19.39	22	24	27	8	2,500	200
SFG18	18	23	16.50	42	71	92	36	M18 x 1,5	31.75	21.89	25	27	31	10	2,940	280
SFG20	20	25	18	46	77	100	40	M20 x 1,5	34.92	24.38	27.50	30	34	10	3,430	370
SFG22	22	28	20	50	84	109	43	M22 x 1,5	38.10	25.84	30	34	37	12	4,120	480
SFG25	25	31	22	56	94	122	48	M24 x 2	42.85	29.60	33.50	36	42	12	5,000	670

Outer Member: Carbon steel, with protective coating for corrosion resistance

Ball: Chrome steel, heat treated

Inserts: Brass

NOTES

- ① Add letter "L" to prefix to indicate Left Hand thread
Example: SFL8
- ② Also available: extra capacity, stainless steel, chrome-plated ball, reduced play. Consult factory for information
- ③ Letter "G" indicates lubricator (SFG10 to SFG25)

STATIC RADIAL LOAD

The maximum static radial load permissible for a rod end depends on three factors: race material compressive strength; rod end head strength; and shank strength. The maximum static radial load is determined by taking the *lowest* of the three following values:

- Race material compressive strengths (R)

$$R = E \times H \times X$$

- Rod end head strength (T)

insert construction

$$T = [D - (E + .176 H)] \times H \times X$$

cartridge type construction

$$T_1 = [\left(\frac{H}{2} \sqrt{D^2 - H^2} \right) + \left(\frac{D^2}{2} \times \sin^{-1} \frac{H}{D} \right) - (O.D. \text{ of bearing} \times H)] \times X$$

angle of $\frac{H}{D}$ expressed in radians

- Shank Strength (S)

male threaded rod end

$$S = [(\text{root diameter of thread}^2 \times .78) - (N^2 \times .78)] \times X$$

female threaded rod end

$$S_1 = [(J^2 \times .78) - (\text{major diameter of thread}^2 \times .78)] \times X$$

Where:

- E = Ball Diameter
- H = Housing Width
- X = Allowable Stress (see table)
- D = Head Diameter
- N = Diameter of Drilled Hole in Shank of Male Rod Ends
- J = Shank Diameter of Female Rod End

STATIC AXIAL LOAD

The maximum available axial load for a rod end is determined by the following formula. This formula does not take into consideration bending of the shank due to a moment of force. Also, this formula does not consider the strength of the stake in cartridge type of construction.

- Axial Strength (A)

$$A = .78 [(E + .176 H)^2 - E^2] \times X$$

Where:

- X = Allowable Stress (See Table)
- E = Ball Diameter
- H = Housing Width

MATERIAL STRESS TABLE	
Material	Allowable Stress (PSI)
Brass	30,000
Aluminum Bronze	35,000
300 Series Stainless Steel	35,000
Low Carbon Steel	52,000
Alloy Steel	140,000

MISALIGNMENT

The angle of misalignment in a rod end is controlled by the outside diameter of the head. The maximum degree of misalignment is obtained when the head contacts the side of the fork or clevis in which it is mounted.

Maximum misalignment is calculated by the following formula.

- Rod End Angle (α):

$$\alpha = \sin^{-1} \frac{W}{D} - \sin^{-1} \frac{H}{D}$$

Where:

- D = Head diameter or diameter of outer race
- H = Housing width
- W = Ball width

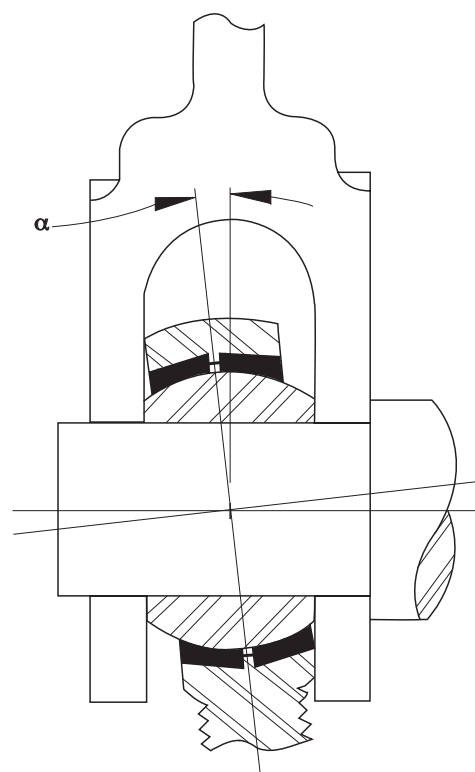

- Angles of misalignment for series:

HM	HF	CMHD	CFHD
HM C	HF C	M CR	F CR
HM M	HF M	HMX G	HFX G
HME M	HFE M	BHM	BHF

ROD END SIZE	MISALIGNMENT +/- DEGREES
2	8.5
2A	7.0
3	6.5
4	8.0
5	7.0
6	6.0
7	7.0
8	6.0
10	8.0
12	7.0
16	8.5

- Angles of misalignment for series:

M M	MD M
-----	------

ROD END SIZE	MISALIGNMENT +/- DEGREES
3414	9.5
3514	8.0
3614	9.5
3616	9.5
4414	10.5
4615	11.0
4616	12.5

- Angles of misalignment for series:

F M

ROD END SIZE	MISALIGNMENT +/- DEGREES
3414	9.5
34714	9.5
3416	10.5
3514	9.5
4414	10.5
4519	11.5

STUDS

Studs are used in combination with Heim rod ends to simplify mounting. Studs are compatible with the following Heim rod end series:

M CR	F CR
HM C	HF C
HM	HF
CMHD	CFHD

The stud is designed to accommodate up to $\pm 25^\circ$ misalignment in any direction and has a wrench flat to facilitate tightening. Add letter "Y" to suffix to indicate stud. Example: CMHD10Y

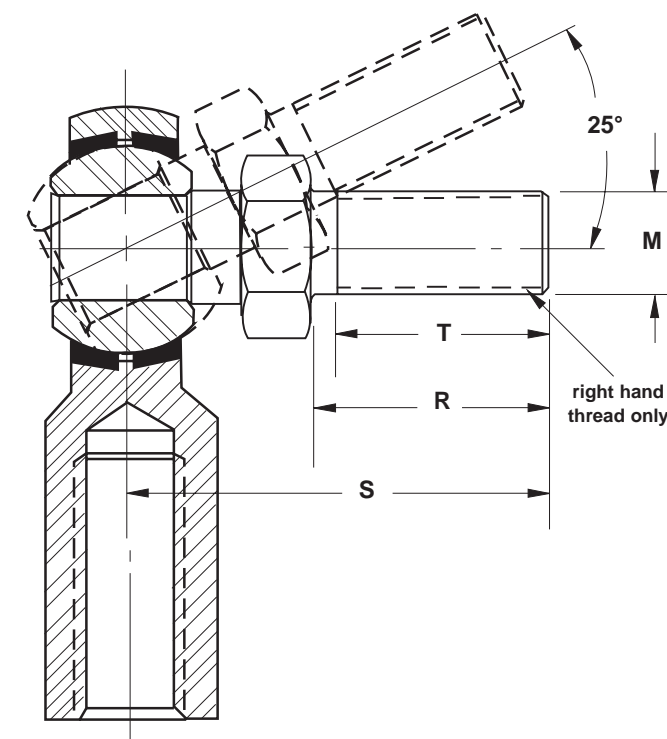

STUD DIMENSIONS

TO FIT ROD END SIZE	DIMENSIONS IN INCHES		
	R	S	M
	+0.010 -0.010	+0.030 -0.030	UNF-2A
3	.500	.969	.1900-32
4	.562	1.047	.2500-28
5	.687	1.234	.3125-24
6	.906	1.540	.3750-24
7	1.125	1.930	.4375-20
8	1.125	2.000	.5000-20
10	1.500	2.500	.6250-18
12	1.812	3.000	.7500-16

KEYWAYS

Keyway slots, where available, are dimensioned as follows. Contact the Heim Engineering Department to determine keyway slot availability on a particular size.

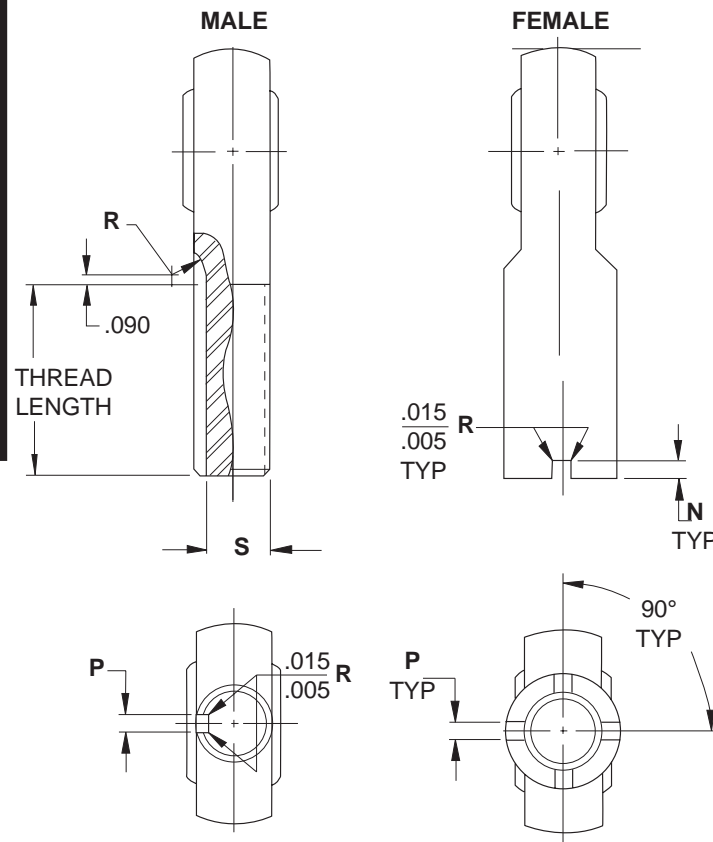

ROD END KEYWAY (Ref NAS 559)				
THREAD OD REF	DIMENSIONS IN INCHES			
	N +.005 -.000	P +.005 -.000	S +.000 -.005	R REF
.2500	.056	.062	.201	.255
.3125	.056	.062	.260	.255
.3750	.056	.093	.311	.255
.4375	.069	.093	.370	.255
.5000	.069	.093	.436	.255
.5625	.077	.125	.478	.255
.6250	.077	.125	.541	.255
.7500	.077	.125	.633	.255
.8750	.086	.156	.777	.318
1.0000	.094	.156	.900	.318
1.1250	.094	.187	1.010	.382
1.2500	.116	.187	1.136	.382
1.3750	.116	.250	1.236	.445
1.5000	.116	.250	1.361	.445
1.6250	.129	.250	1.477	.445
1.7500	.129	.312	1.589	.508
1.8750	.129	.312	1.714	.508
2.0000	.129	.312	1.839	.508
2.1250	.129	.312	1.955	.508
2.2500	.129	.312	2.080	.508

MILITARY SPECIFICATIONS

Many of the processes used by Heim in the manufacture of rod ends are performed to U.S. Military Specifications. A partial list of these specifications follows:

PROCESS	Performed in accordance with:
Anodize	SAE-AMS-A-8625 Type 1 or 2 (formerly MIL-A-8625 Type 1 or 2)
Cadmium Plate	SAE-AMS-QQ-P-416 Type 1 Class 2 (formerly QQ-P-416)
Chrome Plate	SAE-AMS-C-320 Class 2 (.0002 min) (formerly QQ-C-320)
Heat Treat	SAE-AMS-H-6875 (formerly MIL-H-6875) SAE-AMS-H-7199 (formerly MIL-H-7199)
Magnetic Particle Inspection	ASTM-E-1444
Penetrant Inspection	ASTM-1417 (formerly MIL-I-6866)

Design Options

Heim Unibal® rod end and spherical bearings can be ordered with the following design options at extra cost.

DESIGN OPTIONS	OPTION OFFERED ON THESE SERIES	ORDERING INSTRUCTIONS & PART NUMBER EXAMPLE FOR SPECIFYING DESIGN OPTIONS	
Chrome Plated Balls	LS	add "PB" to part number suffix Example: LS6 with a chrome plated ball would be an LS6PB	
Cross Drilled Oil Hole	LSS LHA LHB LHSS	COS COM LH	add "G" to part number suffix Example: an LSS8 with cross drilled oil hole in ball and race and groved I.D. on the ball would be an LSS8G
Keyway/Keyslot (per NAS 559)	HM HM C HM M HME M HMX G M M BHM	HF HF C HF M HFE M HFX G F M	add "K" to part number prefix Example: an HME8M with a keyway would be an HMKE8M. (See page 30 for Keyway/Keyslot specifications)
Lubricators -Zerk Type	HM HM C HM M M M M CR BHM	HF HF C HF M F M F CR	add "G" to part number suffix Example: an HM6 with a zerk type lubricator would be an HM6G (available on sizes 4 through 16 only)
-Flush type	HM HM C HM M M M HMX M CR BHM	HF HF C HF M F M HFX F CR	add "FG" to part number suffix Example: an HF6 with a flush type lubricator would be an HF6FG (available on sizes 4 through 16 only)
Stainless Steel Inserts (300 Series)	HM HM C HM M HME M HMX BHM M M LS	HF HF C HF M HFE M HFX F M LSS	add "J" to part number prefix Example: an HF10 with 300 series stainless steel inserts would be an HFJ10 Note: HME M and HFE M have a one piece race (cartridge type)
Stud	HM C CMHD HM M CR	HF C CFHD HF F CR	add "Y" to part number suffix Example: an HF8C with a stud would be an HF8CY (See page 29 for stud specifications.)

Precision Special Purpose Series

Four Piece - Metal-to-Metal

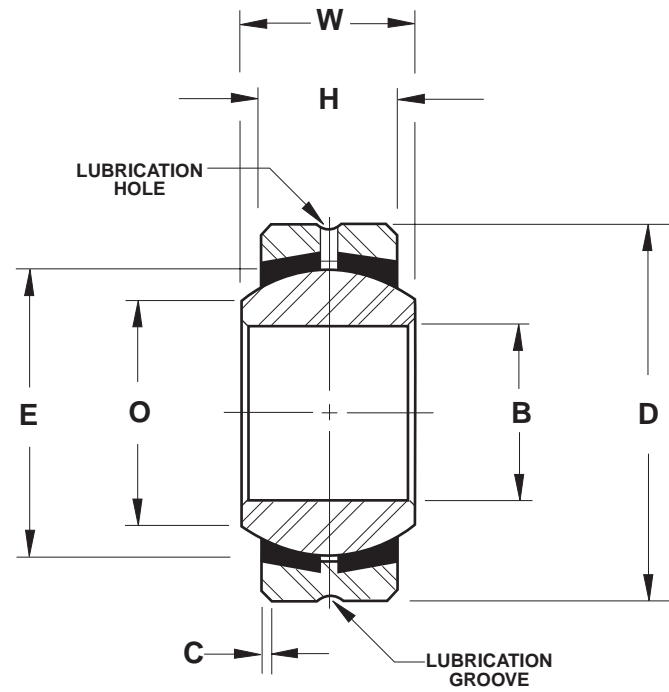

Series LSS

SPHERICAL BEARING NUMBER	DIMENSIONS IN INCHES							MAXIMUM STATIC RADIAL LOAD	APPROX WEIGHT
	BORE	OUTSIDE DIAMETER	BALL WIDTH	HOUSING WIDTH	CHAMFER	BALL DIAMETER	BALL FLAT DIAMETER		
	B	D	W	H	C	E	O		
	+0.0000 -0.0005	+0.0000 -0.0005	+0.000 -0.005	+0.000 -0.005	+0.015 -0.000	REF	REF	LBF	LBS
LSS2	.1650	.4687	.250	.187	.020	.343	.235	2,000	.01
LSS3	.1900	.5625	.281	.218	.020	.406	.293	2,750	.02
LSS4	.2500	.6562	.343	.250	.022	.500	.364	4,200	.02
LSS5	.3125	.7500	.375	.281	.022	.562	.419	5,800	.03
LSS6	.3750	.8125	.406	.312	.032	.625	.475	7,150	.04
LSS7	.4375	.9062	.437	.343	.032	.687	.530	8,625	.05
LSS8	.5000	1.0000	.500	.390	.032	.781	.600	11,200	.07
LSS9	.5625	1.0937	.562	.437	.032	.875	.670	14,000	.09
LSS10	.6250	1.1875	.625	.500	.032	.968	.739	17,700	.12
LSS12	.7500	1.4375	.750	.593	.044	1.187	.920	25,750	.21
LSS14	.8750	1.5625	.875	.703	.044	1.312	.980	33,600	.27
LSS16	1.0000	1.7500	1.000	.797	.044	1.500	1.118	37,520	.38

Outer Member: 4130 or 4340 Alloy steel, heat treated, with protective coating for corrosion resistance on all surfaces exposed after installation.

Ball: 52100 Alloy steel, heat treated, chrome plated

Inserts: Copper alloy

NOTES

- 1 For design options, see page 31
- 2 For Engineering data, see pages 49 and 50
- 3 "H" tolerance across inserts is +/-0.015

Precision Special Purpose Series

Four Piece - Metal-to-Metal

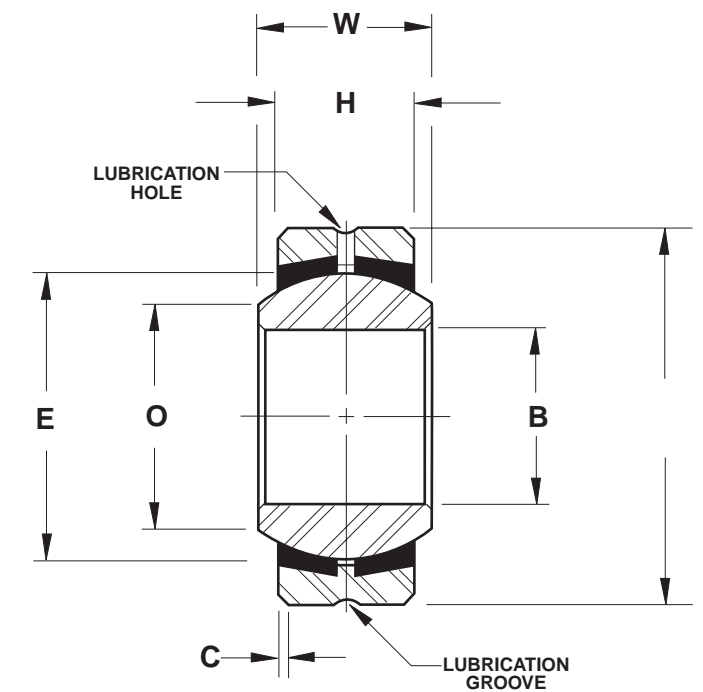

Series LS

SPHERICAL BEARING NUMBER	DIMENSIONS IN INCHES							MAXIMUM STATIC RADIAL LOAD	APPROX WEIGHT
	BORE	OUTSIDE DIAMETER	BALL WIDTH	HOUSING WIDTH	CHAMFER	BALL DIAMETER	BALL FLAT DIAMETER		
	B	D	W	H	C	E	O		
	+0.0000 -0.0005	+0.0000 -0.0005	+0.000 -0.005	+0.000 -0.005	+0.015 -0.000	REF	REF	LBF	LBS
LS3	.1900	.6250	.281	.187	.016	.406	.293	2,960	.02
LS4	.2500	.7500	.375	.281	.016	.515	.354	5,245	.04
LS5	.3125	.8750	.437	.313	.016	.625	.447	6,550	.05
LS6	.3750	1.0000	.500	.375	.016	.718	.517	8,605	.08
LS7	.4375	1.1875	.562	.437	.032	.812	.586	11,100	.12
LS8	.5000	1.3125	.687	.531	.044	.937	.637	15,600	.18
LS10	.6250	1.5625	.875	.687	.044	1.187	.802	25,700	.33
LS12	.7500	2.2500	1.250	.937	.044	1.625	1.038	47,600	.97
LS16	1.0000	2.3750	1.125	.875	.062	1.750	1.345	48,200	.94
LS19	1.1875	2.6250	1.250	1.000	.085	2.000	1.562	63,000	1.27
LS24	1.5000	3.2500	1.500	1.250	.085	2.500	2.000	98,000	2.38
LS30	1.8750	4.0000	1.625	1.313	.125	3.000	2.521	123,500	3.75

Outer Member: Carbon steel, with protective coating for corrosion resistance on all surfaces exposed after installation

Ball: 52100 Alloy steel, heat treated

Inserts: Brass

NOTES

- 1 For design options, see page 31
- 2 For Engineering data, see pages 49 and 50
- 3 "H" tolerance across inserts is +/-0.015

Precision Series

Two Piece - Metal-to-Metal

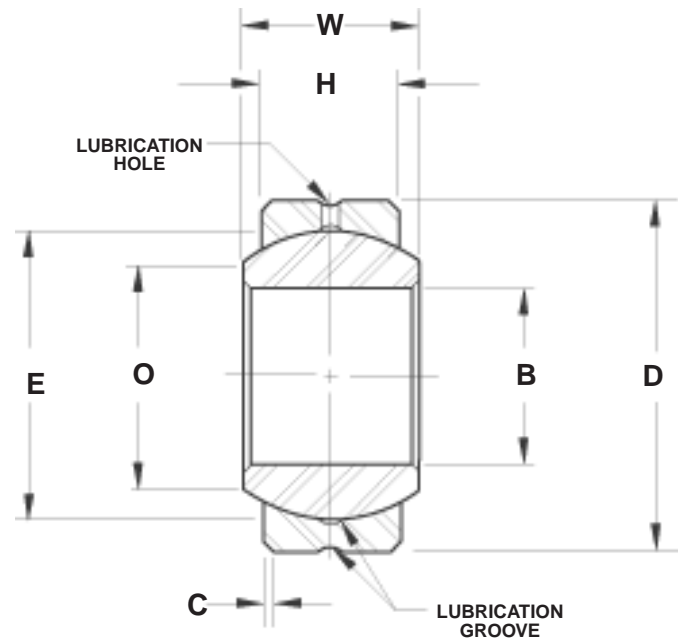

Series LHA, LHB, LHSS

SPHERICAL BEARING NUMBER	DIMENSIONS IN INCHES								MAXIMUM STATIC RADIAL LOAD			APPROX WEIGHT LBS	
	BORE	OUTSIDE DIAMETER	BALL WIDTH	HOUSING WIDTH	CHAMFER	BALL DIAMETER	BALL FLAT DIAMETER	LHA SERIES	LHB SERIES	LHSS SERIES			
	B	D	W	H	C	E	O						
	+0.000 -0.0005	+0.000 -0.0005	+0.000 -0.005	+0.005 -0.005	+0.015 -0.000	REF	REF						
LHA2	LHB2	LHSS2	.1650	.4687	.250	.187	.020	.343	.235	4,400	2,000	2,900	.01
LHA3	LHB3	LHSS3	.1900	.5625	.281	.218	.020	.406	.293	6,480	2,750	4,000	.02
LHA4	LHB4	LHSS4	.2500	.6562	.343	.250	.022	.500	.364	10,000	4,200	5,650	.02
LHA5	LHB5	LHSS5	.3125	.7500	.375	.281	.022	.562	.419	13,900	5,800	7,150	.03
LHA6	LHB6	LHSS6	.3750	.8125	.406	.312	.032	.625	.475	18,750	7,750	8,800	.04
LHA7	LHB7	LHSS7	.4375	.9062	.437	.343	.032	.687	.530	22,300	9,300	10,600	.05
LHA8	LHB8	LHSS8	.5000	1.0000	.500	.390	.032	.781	.600	26,900	11,200	13,700	.07
LHA9	LHB9	LHSS9	.5625	1.0937	.562	.437	.032	.875	.670	36,000	14,800	17,200	.09
LHA10	LHB10	LHSS10	.6250	1.1875	.625	.500	.032	.968	.739	48,000	20,000	21,800	.12
LHA12	LHB12	LHSS12	.7500	1.4375	.750	.593	.044	1.187	.920	78,000	30,000	31,800	.21
LHA14	LHB14	LHSS14	.8750	1.5625	.875	.703	.044	1.312	.980	103,000	43,000	41,500	.27
LHA16	LHB16	LHSS16	1.0000	1.7500	1.000	.797	.044	1.500	1.118	125,000	52,000	53,800	.38

Outer Member: LHA: 4130 or 4340 Alloy steel, heat treated, with protective coating for corrosion resistance on all surfaces exposed after installation
 LHB: Aluminum bronze
 LHSS: 300 Series stainless steel

Ball: LHA: 52100 Alloy steel, heat treated, chrome plated
 LHB: 52100 Alloy steel, heat treated, chrome plated
 LHSS: 440C Stainless steel, heat treated

NOTES
 1 For design options, see page 31
 2 For Engineering data, see pages 49 and 50

Precision Series

Two Piece - Metal-to-Metal

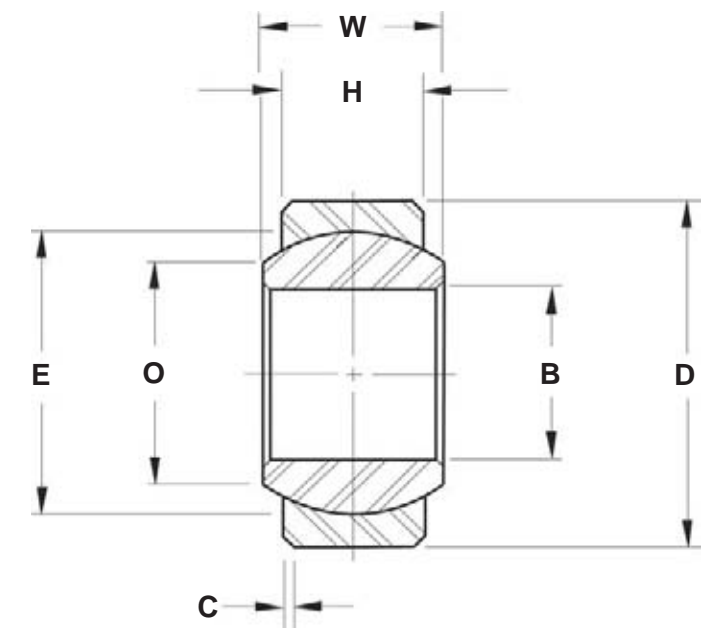

Series COS

SPHERICAL BEARING NUMBER	DIMENSIONS IN INCHES								MAXIMUM STATIC RADIAL LOAD			
	BORE	OUTSIDE DIAMETER	BALL WIDTH	HOUSING WIDTH	CHAMFER	BALL DIAMETER	BALL FLAT DIAMETER	LHA SERIES	LHB SERIES			
	B	D	W	H	C	E	O					
	+0.000 -0.0005	+0.000 -0.0005	+0.000 -0.005	+0.005 -0.005	+0.015 -0.000	REF	REF					
COS3	COS4	COS5	COS6	COS7	COS8	COS9	COS10	COS12	COS14	COS16	LBF	LBS
.1900	.2500	.3125	.3750	.4375	.5000	.5625	.6250	.7500	.8750	1.0000	4,800	7,500
.4687	.6562	.7500	.8125	.9062	1.0000	1.0937	1.1875	1.4375	1.5625	1.7500	10,400	14,000
.281	.343	.375	.406	.437	.500	.562	.625	.750	.875	1.000	16,750	20,000
.187	.218	.281	.312	.343	.390	.437	.500	.593	.703	.797	27,000	36,000
.020	.022	.022	.032	.032	.032	.032	.032	.044	.044	.044	54,000	77,000
.343	.364	.419	.475	.530	.600	.670	.739	.920	.980	1.118	93,500	

Outer Member: 17-4 PH Stainless steel, heat treated

Ball: 440C Stainless steel, heat treated, chrome plated

NOTES
 1 For design options, see page 31
 2 For Engineering data, see pages 49 and 50

Precision Series

Self-Lubricating

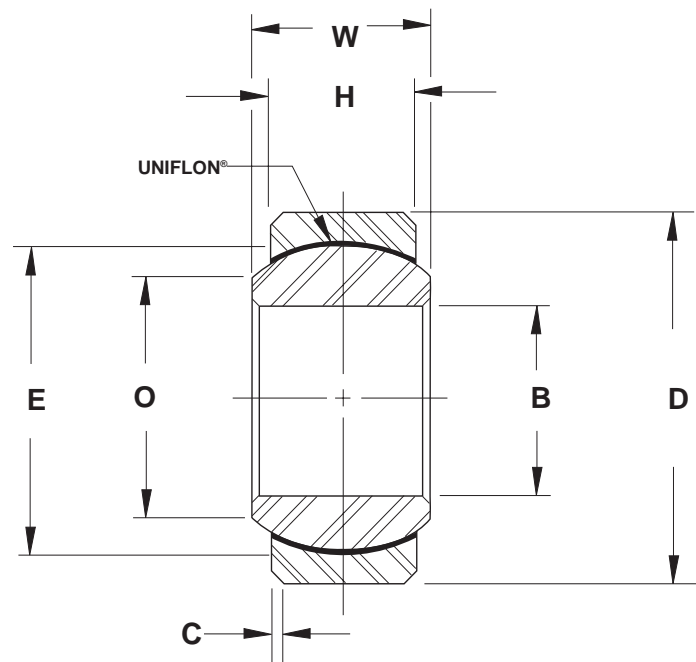

Series LHSSE

SPHERICAL BEARING NUMBER	DIMENSIONS IN INCHES							MAXIMUM STATIC RADIAL LOAD	APPROX WEIGHT
	BORE	OUTSIDE DIAMETER	BALL WIDTH	HOUSING WIDTH	CHAMFER	BALL DIAMETER	BALL FLAT DIAMETER		
	B	D	W	H	C	E	O		
	+0.000 -0.0005	+0.000 -0.0005	+0.000 -0.005	+0.005 -0.005	+0.015 -0.000	REF	REF	LBF	LBS
LHSSE2	.1650	.4687	.250	.187	.020	.343	.235	3,200	.01
LHSSE3	.1900	.5625	.281	.218	.020	.406	.293	4,400	.02
LHSSE4	.2500	.6562	.343	.250	.022	.500	.364	6,700	.02
LHSSE5	.3125	.7500	.375	.281	.022	.562	.419	9,200	.03
LHSSE6	.3750	.8125	.406	.312	.032	.625	.475	11,700	.04
LHSSE7	.4375	.9062	.437	.343	.032	.687	.530	14,100	.05
LHSSE8	.5000	1.0000	.500	.390	.032	.781	.600	17,900	.07
LHSSE9	.5625	1.0937	.562	.437	.032	.875	.670	22,900	.09
LHSSE10	.6250	1.1875	.625	.500	.032	.968	.739	29,000	.12
LHSSE12	.7500	1.4375	.750	.593	.044	1.187	.920	42,200	.21
LHSSE14	.8750	1.5625	.875	.703	.044	1.312	.980	55,300	.27
LHSSE16	1.0000	1.7500	1.000	.797	.044	1.500	1.118	71,700	.38

Outer Member: 300 Series stainless steel

Ball: 440C Stainless steel, heat treated

Liner: "E" UNIFLON®

NOTES

- 1 For liner specification, see page 54
- 2 For Engineering data, see pages 49 thru 50

Precision Series

Self-Lubricating

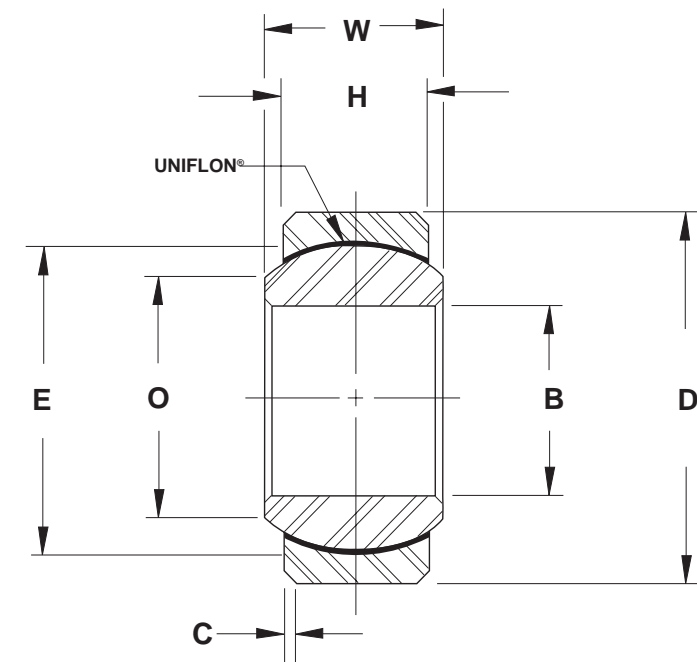

Series LHSSVV

SPHERICAL BEARING NUMBER	DIMENSIONS IN INCHES							MAXIMUM STATIC RADIAL LOAD	APPROX WEIGHT
	BORE	OUTSIDE DIAMETER	BALL WIDTH	HOUSING WIDTH	CHAMFER	BALL DIAMETER	BALL FLAT DIAMETER		
	B	D	W	H	C	E	O		
	+0.000 -0.0005	+0.000 -0.0005	+0.000 -0.005	+0.005 -0.005	+0.015 -0.000	REF	REF	LBF	LBS
LHSSVV2	.1650	.4687	.250	.187	.020	.343	.235	2,000	.01
LHSSVV3	.1900	.5625	.281	.218	.020	.406	.293	2,750	.02
LHSSVV4	.2500	.6562	.343	.250	.022	.500	.364	4,200	.02
LHSSVV5	.3125	.7500	.375	.281	.022	.562	.419	5,800	.03
LHSSVV6	.3750	.8125	.406	.312	.032	.625	.475	7,750	.04
LHSSVV7	.4375	.9062	.437	.343	.032	.687	.530	9,300	.05
LHSSVV8	.5000	1.0000	.500	.390	.032	.781	.600	11,200	.07
LHSSVV9	.5625	1.0937	.562	.437	.032	.875	.670	14,800	.09
LHSSVV10	.6250	1.1875	.625	.500	.032	.968	.739	20,000	.12
LHSSVV12	.7500	1.4375	.750	.593	.044	1.187	.920	30,000	.21
LHSSVV14	.8750	1.5625	.875	.703	.044	1.312	.980	43,000	.27
LHSSVV16	1.0000	1.7500	1.000	.797	.044	1.500	1.118	52,000	.38

Outer Member: 300 Series stainless steel

Ball: 440C Stainless steel, heat treated

Liner: "VV" UNIFLON®

NOTES

- 1 For liner specification, see page 54
- 2 For Engineering data, see pages 49 thru 50

Commercial Series

Two Piece - Metal-to-Metal

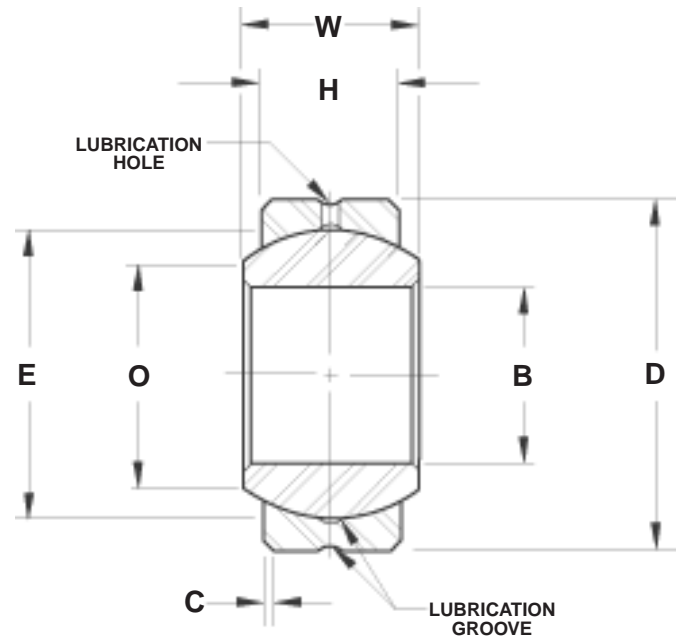

Series COM

SPHERICAL BEARING NUMBER	DIMENSIONS IN INCHES							MAXIMUM STATIC RADIAL LOAD	APPROX WEIGHT
	BORE	OUTSIDE DIAMETER	BALL WIDTH	HOUSING WIDTH	CHAMFER	BALL DIAMETER	BALL FLAT DIAMETER		
	B	D	W	H	C	E	O		
	+0.0025 -.0005	+0.0000 -.0007	+0.005 -.005	+0.010 -.010	+0.015 -.000	REF	REF	LBF	LBS
COM3	.1900	.5625	.281	.218	.020	.406	.293	3,250	.02
COM4	.2500	.6562	.343	.250	.022	.500	.364	4,900	.02
COM5	.3125	.7500	.375	.281	.032	.562	.419	6,450	.03
COM6	.3750	.8125	.406	.312	.032	.625	.475	8,250	.04
COM7	.4375	.9062	.437	.343	.032	.687	.530	10,200	.05
COM8	.5000	1.0000	.500	.390	.032	.781	.600	13,600	.07
COM9	.5625	1.0937	.562	.437	.032	.875	.670	15,900	.09
COM10	.6250	1.1875	.625	.500	.032	.968	.739	21,000	.12
COM12	.7500	1.4375	.750	.593	.044	1.187	.920	30,000	.21
COM14	.8750	1.5625	.875	.703	.044	1.312	.980	41,100	.27
COM16	1.0000	1.7500	1.000	.797	.044	1.500	1.118	54,700	.38

Outer Member: Carbon steel

Ball: 52100 Alloy steel, heat treated, chrome plated

NOTES

- 1 For design options, see page 31
- 2 For Engineering data, see pages 49 thru 50

Commercial Series

Two Piece - Metal-to-Metal

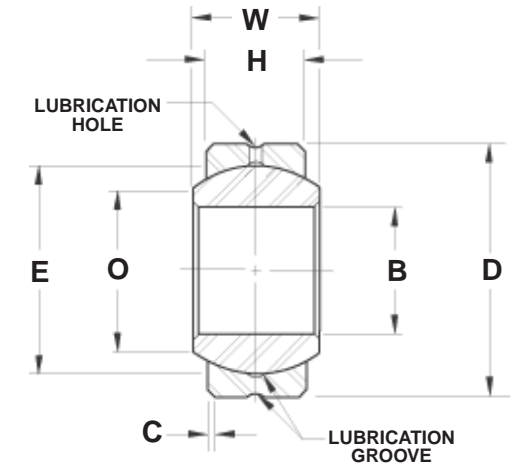

Series LH D

SPHERICAL BEARING NUMBER	DIMENSIONS IN INCHES							MAXIMUM STATIC RADIAL LOAD
	BORE	OUTSIDE DIAMETER	BALL WIDTH	HOUSING WIDTH	CHAMFER	BALL DIAMETER	BALL FLAT DIAMETER	
	B	D	W	H	C	E	O	
	+0.0000 -.0007	+0.0000 -.0007	+0.000 -.005	+0.007 -.007	+0.015 -.000	REF	REF	LBF
LH16D	1.0000	2.0000	1.000	.781	.035	1.688	1.360	68,525
LH19D	1.1875	2.3750	1.187	.937	.035	2.000	1.610	97,440
LH20D	1.2500	2.3750	1.187	.937	.035	2.000	1.610	97,440
LH24D	1.5000	2.7500	1.375	1.094	.035	2.313	1.860	131,550
LH28D	1.7500	3.1250	1.562	1.250	.040	2.625	2.080	169,000
LH32D	2.0000	3.5000	1.750	1.375	.040	2.938	2.360	209,985

Outer Member: Carbon steel, with protective coating for corrosion resistance on all surfaces exposed after installation

Ball: 52100 Alloy steel, heat treated, chrome plated

NOTES

- 1 For design options, see page 31
- 2 For Engineering data, see pages 49 thru 50

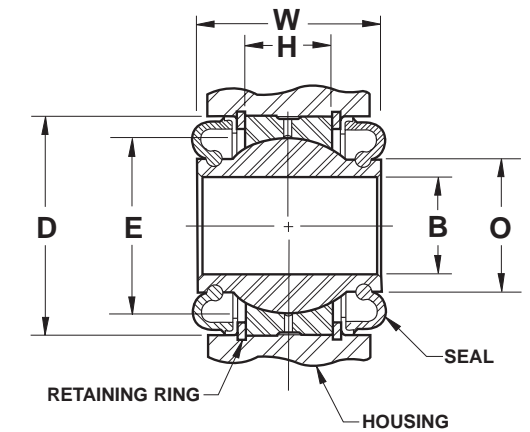

Series LH PP

SPHERICAL BEARING NUMBER	BORE	OUTSIDE DIAMETER	HOUSING WIDTH	BALL WIDTH	BALL DIAMETER	BALL FLAT DIAMETER	APPROX. ANGLE OF MISALIGNMENT W/SEALS	MAXIMUM STATIC RADIAL LOAD	APPROX WEIGHT
	B	D	H	W	E	O			
	+0.0000 -.0007	+0.0000 -.0007	+0.000 -.005	+0.000 -.005	REF	REF			
LH12PP	.7500	1.5000	.500	1.250	1.250	1.000	12 1/2	31,500	.25
LH16PP	1.0000	2.2500	.875	1.875	1.813	1.375	12 1/2	83,500	.95
LH20PP	1.2500	2.3750	.875	1.875	2.000	1.625	12 1/2	94,000	.99
LH24PP	1.5000	2.7500	1.000	1.875	2.375	2.000	12 1/2	130,000	1.44

Outer Member: Carbon steel, with protective coating for corrosion resistance

Ball: 52100 Alloy steel, heat treated, chrome plated

Seals: Synthetic rubber



Military Series (MS14104, MS14101) Self-Lubricating

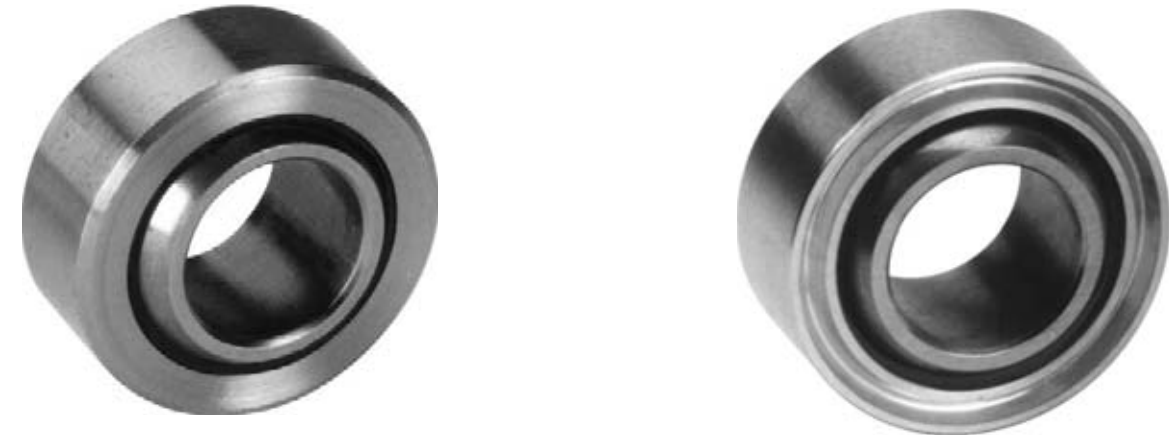

Military Series (MS14104, MS14101) Self-Lubricating

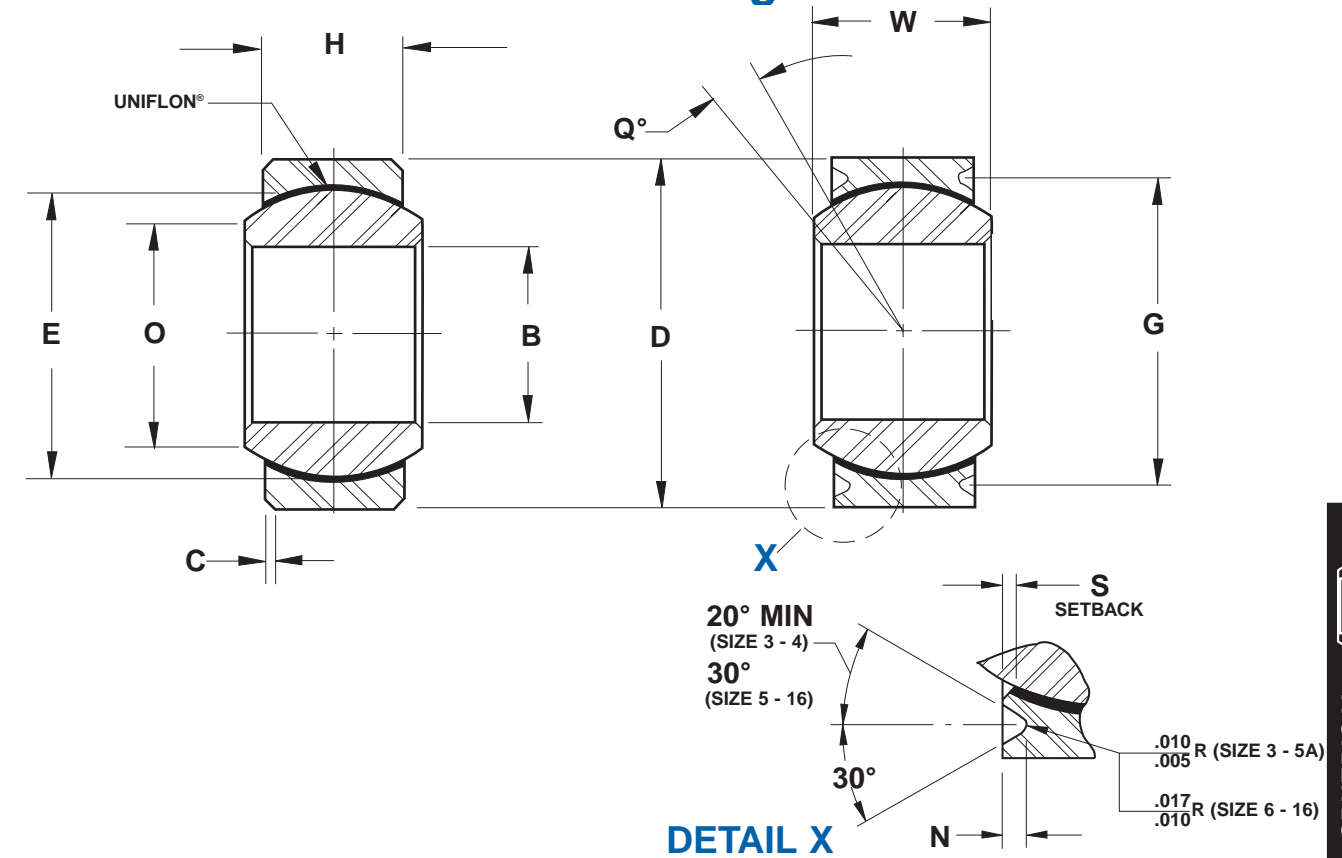

Series NE, NEG

PLAIN		GROOVED		DIMENSIONS IN INCHES												BALL DIAMETER	BALL FLAT DIAMETER	STATIC LIMIT LOAD		OSCILLATING LOAD	NO LOAD ROTATIONAL BREAKAWAY TORQUE (RANGE)	APPROX WEIGHT
HEIM PART NO	MS14104 DASH NO	HEIM PART NO	MS14101 DASH NO	BORE	OUTSIDE DIAMETER	BALL WIDTH	HOUSING WIDTH	OTHER DIMENSIONS				REF	REF	LBF				LBF	IN-LBS			
				B +.0000 -.0005	D +.0000 -.0005	W +.000 -.002	H +.005 -.005	N +.000 -.015	G +.000 -.008	C +.005 -.005	S MAX	E REF	O REF	Q DEG MIN	RADIAL	AXIAL						
NE3	3	NEG3	3	.1900	.5625	.281	.218	.025	.500	.015	.030	.406	.293	10	3,975	150	1,500	0.25-5	.020			
NE4	4	NEG4	4	.2500	.6562	.343	.250	.025	.594	.015	.030	.500	.364	10	6,040	430	3,320	0.25-5	.020			
NE5	5	NEG5A	5A	.3125	.7500	.375	.281	.035	.660	.015	.030	.562	.419	10	8,750	700	5,460	0.25-8	.030			
NE6	6	NEG6	6	.3750	.8125	.406	.312	.035	.712	.025	.035	.625	.475	9	10,540	1,100	6,600	0.25-8	.040			
NE7	7	NEG7	7	.4375	.9062	.437	.343	.035	.806	.025	.035	.687	.530	8	13,200	1,400	8,050	0.25-8	.050			
NE8	8	NEG8	8	.5000	1.0000	.500	.390	.055	.876	.025	.035	.781	.600	8	17,900	2,100	10,400	0.25-8	.070			
NE9	9	NEG9	9	.5625	1.0937	.562	.437	.055	.970	.025	.040	.875	.670	8	23,200	3,680	13,000	0.25-8	.090			
NE10	10	NEG10	10	.6250	1.1875	.625	.500	.055	1.063	.025	.040	.968	.739	8	30,500	4,720	16,450	0.25-8	.120			
NE12	12	NEG12	12	.7500	1.4375	.750	.593	.055	1.313	.035	.045	1.187	.920	8	46,400	6,750	23,600	0.25-8	.210			
NE14	14	NEG14	14	.8750	1.5625	.875	.703	.055	1.438	.035	.045	1.312	.980	8	62,200	9,350	30,250	0.25-12	.270			
NE16	16	NEG16	16	1.0000	1.7500	1.000	.797	.055	1.626	.035	.045	1.500	1.118	9	82,200	12,160	38,000	0.25-12	.390			

Outer Member: 17-4PH Stainless steel heat treated

Ball: 440C Stainless steel heat treated

Liner: Self-lubricating "E" UNIFLON® per SAE-AS81820 (formerly MIL-B-81820)

NOTES

- For liner specification, see page 54
- Heim is qualified to supply this part and all variations per SAE-AS81820 (formerly MIL-B-81820)



Military Series

(M81820/4, M81820/1)
Self-Lubricating



Military Series

(M81820/4, M81820/1)
Self-Lubricating

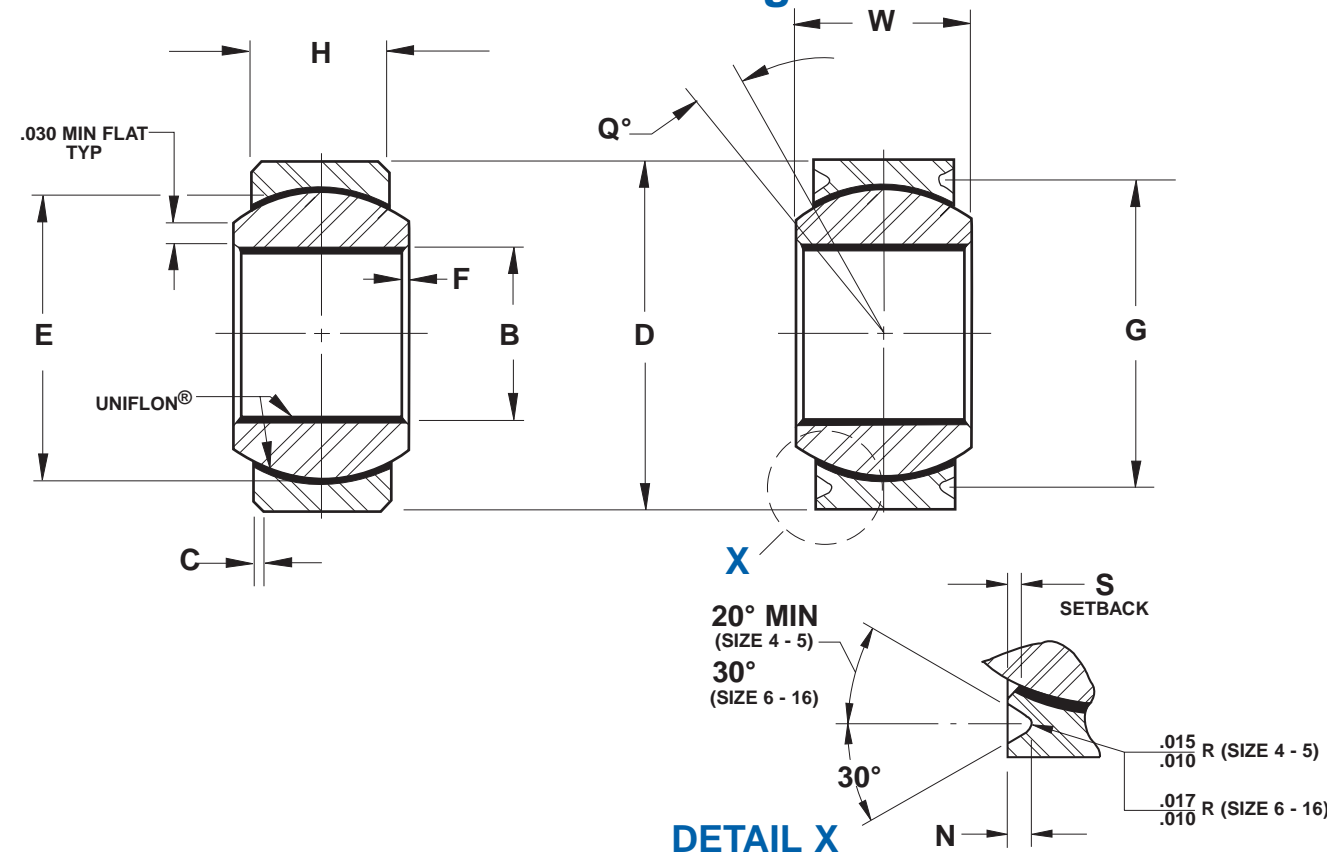

Series NEE, NEEG

PLAIN		GROOVED		DIMENSIONS IN INCHES											STATIC LIMIT LOAD		OSCILLATING LOAD	NO LOAD ROTATIONAL BREAKAWAY TORQUE (RANGE)	APPROX WEIGHT
HEIM PART NO	M81820/4 DASH NO	HEIM PART NO	M81820/1 DASH NO	BORE	OUTSIDE DIAMETER	BALL WIDTH	HOUSING WIDTH	BALL DIAMETER	OTHER DIMENSIONS					LBF					
				B	D	W	H	E	G	S	F	N	C	Q	RADIAL	AXIAL	LBF	IN-LBS	LBS
				+0.000 - .0010	+0.000 - .0005	+0.000 - .002	+0.005 - .005	REF	+0.000 - .008	MAX	MAX	+0.000 - .010	+0.005 - .005	DEG MIN					
NEE4	4	NEEG4	4	.2510	.6562	.343	.250	.500	.594	.030	.010	.025	.015	10	5,550	430	2,650	1-5	.02
NEE5	5	NEEG5	5	.3135	.7500	.375	.281	.562	.660	.030	.010	.035	.015	10	7,700	700	3,700	1-15	.03
NEE6	6	NEEG6	6	.3760	.8125	.406	.312	.625	.712	.035	.025	.035	.025	9	10,200	1,100	4,900	1-15	.04
NEE7	7	NEEG7	7	.4385	.9062	.437	.343	.678	.806	.035	.025	.035	.025	8	12,950	1,400	6,700	1-15	.05
NEE8	8	NEEG8	8	.5010	1.0000	.500	.390	.781	.876	.035	.025	.055	.025	8	17,250	2,100	8,250	1-15	.07
NEE9	9	NEEG9	9	.5635	1.0937	.562	.437	.875	.970	.040	.025	.055	.025	8	22,150	3,680	10,600	1-15	.09
NEE10	10	NEEG10	10	.6260	1.1875	.625	.500	.968	1.063	.040	.025	.055	.025	8	27,700	4,720	13,250	1-15	.12
NEE12	12	NEEG12	12	.7510	1.4375	.750	.593	1.187	1.313	.045	.025	.055	.035	8	40,600	6,750	19,400	1-15	.21
NEE14	14	NEEG14	14	.8760	1.5625	.875	.703	1.312	1.438	.045	.025	.055	.035	8	55,950	9,350	26,750	1-25	.27
NEE16	16	NEEG16	16	1.0010	1.7500	1.000	.797	1.500	1.626	.045	.025	.055	.035	9	73,800	12,160	35,250	1-25	.39

Outer Member: 17-4PH Stainless steel heat treated

Ball: PH13-8MO Stainless steel heat treated

Liner: Self-lubricating "E" UNIFLON® per SAE-AS81820 (formerly MIL-B-81820)

NOTES

- For liner specification, see page 54
- Heim is qualified to supply this part and all variations per SAE-AS81820 (formerly MIL-B-81820)

Military Series (MS14102, MS14103) Self-Lubricating



Military Series (MS14102, MS14103) Self-Lubricating

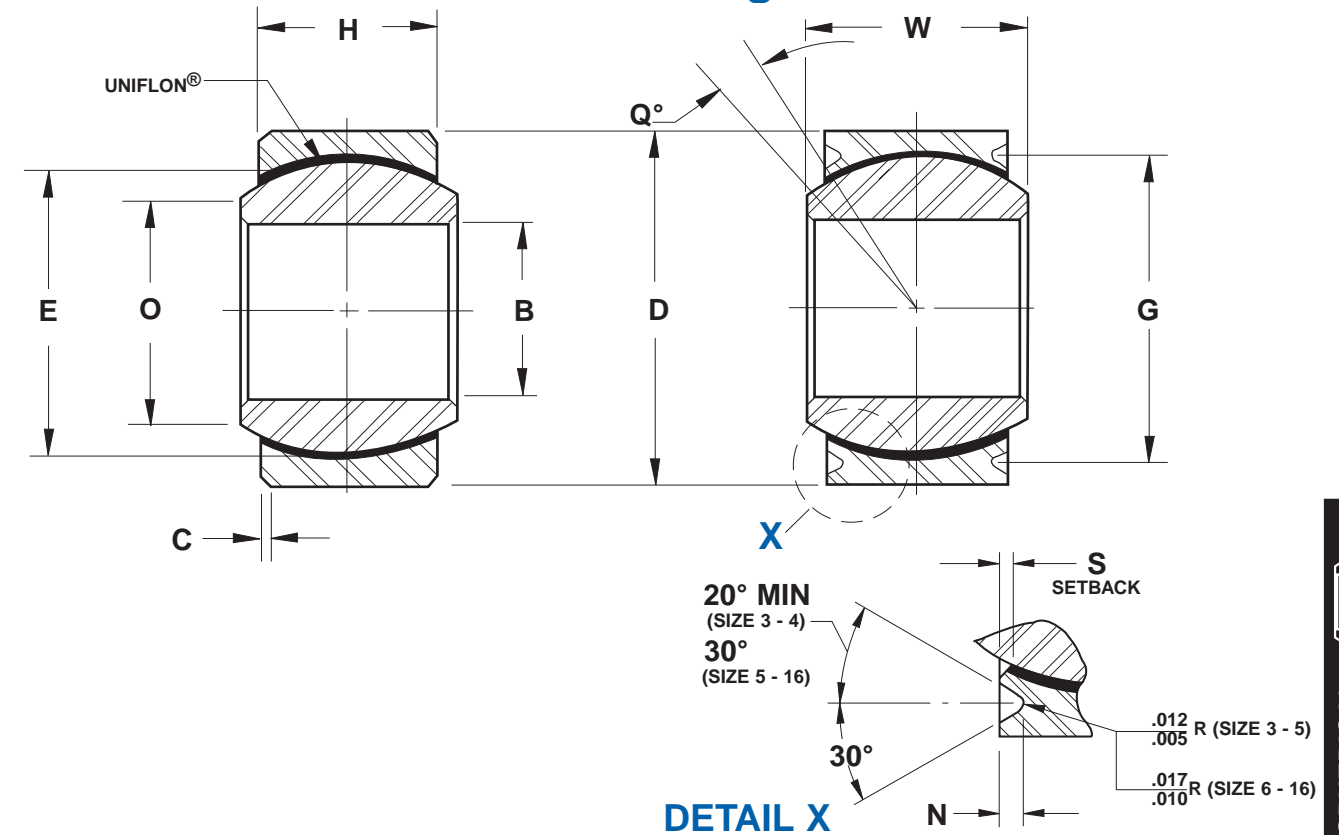

Series WE, WEG

PLAIN		GROOVED		DIMENSIONS IN INCHES										BALL DIAMETER	BALL FLAT DIAMETER	STATIC LIMIT LOAD		OSCILLATING LOAD	NO LOAD ROTATIONAL BREAKAWAY TORQUE (RANGE)	APPROX WEIGHT
HEIM PART NO	MS14102 DASH NO	HEIM PART NO	MS14103 DASH NO	BORE	OUTSIDE DIAMETER	BALL WIDTH	HOUSING WIDTH	OTHER DIMENSIONS				E	O			Q	RADIAL			
				B +.0000 -.0005	D +.0000 -.0005	W +.000 -.002	H +.005 -.005	N +.000 -.010	G +.000 -.008	C +.005 -.005	S MAX	REF	REF	DEG MIN						
WE3	3	WEG3	3	.1900	.6250	.437	.327	.025	.563	.015	.030	.531	.300	15	2,500	1,770	4,990	0.25-5	.031	
WE4	4	WEG4	4	.2500	.6250	.437	.327	.025	.563	.015	.030	.531	.300	15	5,500	1,770	4,990	0.25-5	.031	
WE5	5	WEG5	5	.3125	.6875	.437	.317	.035	.625	.015	.030	.593	.401	14	9,400	1,640	6,050	0.25-8	.035	
WE6	6	WEG6	6	.3750	.8125	.500	.406	.035	.712	.025	.035	.687	.466	8	13,700	2,630	8,310	0.25-8	.060	
WE7	7	WEG7	7	.4375	.9375	.562	.442	.035	.837	.025	.035	.781	.537	10	20,700	3,650	11,750	0.25-8	.080	
-	-	WEG7A	7A	.4375	.9062	.562	.442	.035	.806	.025	.035	.781	.537	10	19,700	3,650	11,750	0.25-8	.080	
WE8	8	WEG8	8	.5000	1.0000	.625	.505	.035	.900	.025	.045	.875	.607	9	21,400	4,970	14,950	0.25-8	.100	
WE9	9	WEG9	9	.5625	1.1250	.687	.536	.035	1.025	.025	.040	1.000	.721	10	26,600	5,370	18,100	0.25-8	.135	
WE10	10	WEG10	10	.6250	1.1875	.750	.567	.035	1.087	.025	.040	1.062	.747	12	29,000	6,130	20,250	0.25-8	.160	
WE12	12	WEG12	12	.7500	1.3750	.875	.630	.055	1.251	.035	.045	1.250	.887	13	37,000	7,730	26,200	0.25-8	.240	
WE14	14	WEG14	14	.8750	1.6250	.875	.755	.055	1.501	.035	.045	1.375	1.061	6	65,200	10,800	33,600	0.25-12	.350	
WE16	16	WEG16	16	1.0000	2.1250	1.375	1.005	.055	2.001	.035	.045	1.875	1.269	12	104,000	19,300	56,520	0.25-12	.970	

Outer Member: 17-4PH Stainless steel heat treated

Ball: 440C Stainless steel heat treated

Liner: Self-lubricating "E" UNIFLON® per SAE-AS81820 (formerly MIL-B-81820)

NOTES

- 1 For liner specification, see page 54
- 2 Heim is qualified to supply this part and all variations per SAE-AS81820 (formerly MIL-B-81820)

Military Series

(M81820/2, M81820/3)
Self-Lubricating



Military Series

(M81820/2, M81820/3)
Self-Lubricating

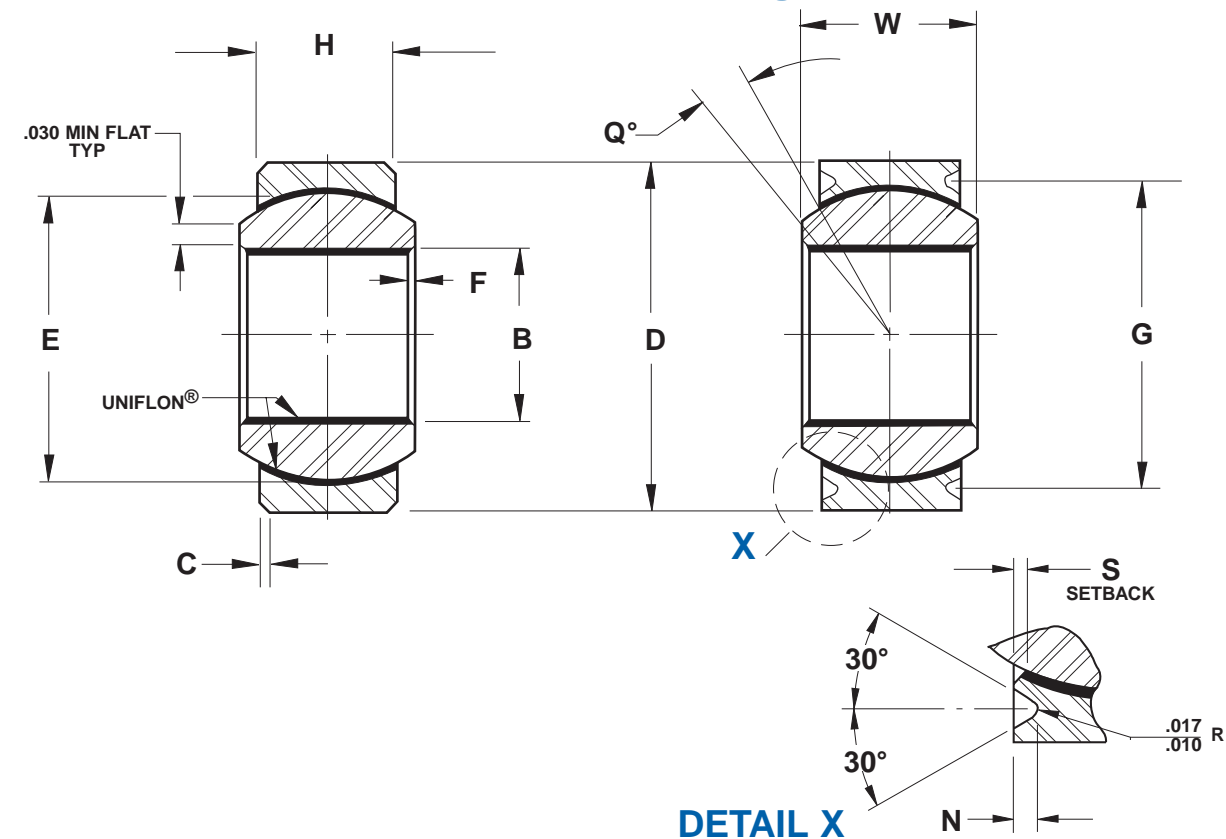

Series WEE, WEEG

PLAIN		GROOVED		DIMENSIONS IN INCHES											STATIC LIMIT LOAD		OSCILLATING LOAD	NO LOAD ROTATIONAL BREAKAWAY TORQUE (RANGE)	APPROX WEIGHT
HEIM PART NO	M81820/2 DASH NO	HEIM PART NO	M81820/3 DASH NO	BORE	OUTSIDE DIAMETER	BALL WIDTH	HOUSING WIDTH	BALL DIAMETER	OTHER DIMENSIONS						LBF				
				B	D	W	H	E	G	S	F	N	C	Q	RADIAL	AXIAL	LBF	IN-LBS	LBS
WEE7	7	WEEG7	7	.4385	.9375	.562	.442	.781	.837	.035	.025	.035	.025	10	17,300	3,650	8,250	1-15	.08
-	-	WEEG7A	7A	.4385	.9062	.562	.442	.781	.806	.035	.025	.035	-	10	17,300	3,650	8,250	1-15	.08
WEE8	8	WEEG8	8	.5010	1.0000	.625	.505	.875	.900	.035	.025	.035	.025	9	21,400	4,970	10,600	1-15	.10
WEE9	9	WEEG9	9	.5635	1.1250	.687	.536	1.000	1.025	.040	.025	.035	.025	10	26,600	5,370	13,200	1-15	.14
WEE10	10	WEEG10	10	.6260	1.1875	.750	.567	1.062	1.087	.040	.025	.035	.025	12	29,000	6,130	16,150	1-15	.16
WEE12	12	WEEG12	12	.7510	1.3750	.875	.630	1.250	1.251	.045	.025	.055	.035	13	37,000	7,730	24,800	1-15	.24
WEE14	14	WEEG14	14	.8760	1.6250	.875	.755	1.375	1.501	.045	.025	.055	.035	6	56,000	10,800	26,750	1-25	.35
WEE16	16	WEEG16	16	1.0010	2.1250	1.375	1.005	1.875	2.001	.045	.025	.055	.035	12	103,000	19,300	49,300	1-25	.97

Outer Member: 17-4PH Stainless steel heat treated

Ball: PH13-8MO Stainless steel heat treated

Liner: Self-lubricating "E" UNIFLON® per SAE-AS81820 (formerly MIL-B-81820)

NOTES

- 1 For liner specification, see page 54
- 2 Heim is qualified to supply this part and all variations per SAE-AS81820 (formerly MIL-B-81820)

Metric Precision Series

Four Piece - Metal-to-Metal

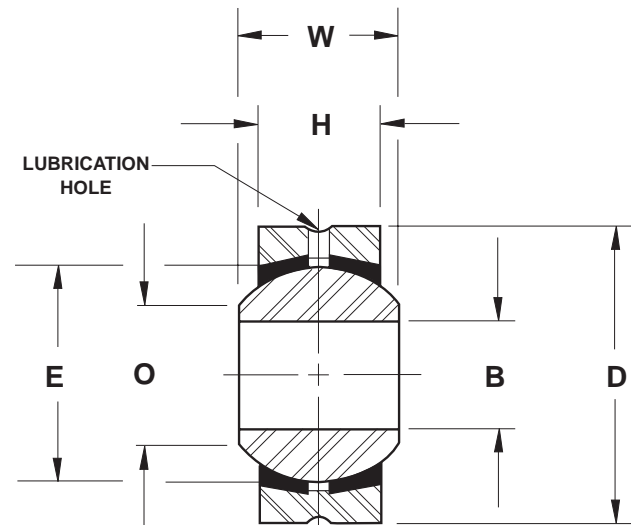

Series SS

SPHERICAL BEARING NUMBER	DIMENSIONS IN MILLIMETERS						MAXIMUM STATIC RADIAL LOAD	APPROX WEIGHT
	BORE	OUTSIDE DIAMETER	BALL WIDTH	HOUSING WIDTH	BALL DIAMETER	BALL FLAT DIAMETER		
	B	D	W	H	E	O		
	H7	h6	+0.00 -.130	+0.00 -.130	REF	REF	daN	g
SS5	5	16	8	6	11.11	7.71	780	9
SS6	6	18	9	6.75	12.70	8.96	980	12
SS8	8	22	12	9	15.88	10.40	1,670	24
SS10	10	26	14	10.5	19.05	12.92	2,350	38
SS12	12	30	16	12	22.23	15.43	3,140	57
SS14	14	34	19	13.5	25.40	16.86	4,020	83
SS16	16	38	21	15	28.58	19.39	5,000	110
SS18	18	42	23	16.5	31.75	21.89	6,180	150
SS20	20	46	25	18	34.92	24.38	7,360	200
SS22	22	50	28	20	38.10	25.84	8,830	250
SS25	25	56	31	22	42.85	29.60	11,080	360

Outer Ring: Carbon steel, with protective coating for corrosion resistance

Ball: Chrome steel, heat treated

Inserts: Brass

NOTES
 ① Also available
 —stainless steel
 —teflon liner
 —chrome plated ball
 —reduced play
 consult factory for information

Spherical Bearing Technical Data

RADIAL LOAD

The maximum static radial load is calculated using the following formula:

$$R = E \times H \times X$$

STATIC AXIAL LOAD

The maximum static axial load is calculated using the following formulae:

- Axial Strength (A)

1. For four piece insert construction bearings

$$A = .78 [(E + .176H)^2 - E^2] \times X$$

2. For two piece (cartridge type) bearings

$$A = .65(H^2) \times X$$

Where:

- E = Ball Diameter
- H = Housing Width
- X = Allowable Stress (see table below)

MATERIAL STRESS TABLE

Material	Allowable Stress (PSI)
Brass	30,000
Aluminum Bronze	35,000
300 Series Stainless Steel	35,000
Low Carbon Steel	52,000
Alloy Steel	140,000

MILITARY SPECIFICATIONS

Many of the processes used by Heim in the manufacture of spherical bearings are performed to U.S. Military Specifications. A partial list of these specifications follows:

PROCESS	Performed in accordance with:
Anodize	SAE-AMS-A-8625 Type 1 or 2 (formerly MIL-A-8625 Type 1 or 2)
Cadmium Plate	SAE-AMS-QQ-P-416 Type 1 Class 2 (formerly QQ-P-416)
Chrome Plate	SAE-AMS-C-320 Class 2 (.0002 min) (formerly QQ-C-320)
Heat Treat	SAE-AMS-H-6875 (formerly MIL-H-6875) SAE-AMS-H-7199 (formerly MIL-H-7199)
Magnetic Particle Inspection	ASTM-E-1444
Penetrant Inspection	ASTM-1417 (formerly MIL-I-6866)

HOUSING BORES

SPHERICAL BEARING SIZE	BEARING OD D	HOUSING BORE			
		STEEL		ALUMINUM	
	+0.000 -0.005	MAX	MIN	MAX	MIN
Series LS					
3	.6250	.6245	.6241	.6244	.6239
4	.7500	.7495	.7491	.7494	.7489
5	.8750	.8745	.8741	.8744	.8739
6	1.0000	.9995	.9991	.9994	.9989
7	1.1875	1.1870	1.1865	1.1869	1.1863
8	1.3125	1.3120	1.3115	1.3119	1.3113
10	1.5625	1.5620	1.5613	1.5619	1.5611
12	2.2500	2.2495	2.2488	2.2494	2.2486
16	2.3750	2.3745	2.3738	2.3744	2.3736
19	2.6250	2.6245	2.6238	2.6244	2.6236
24	3.2500	3.2495	3.2488	3.2494	3.2486
30	4.0000	3.9995	3.9988	3.9994	3.9986
Series LSS, LHA, LHB, LHSS, COM, COS, LHSSE, LHSSV					
2	.4687	.4682	.4678	.4681	.4676
3	.5625	.5620	.5616	.5619	.5614
4	.6562	.6557	.6553	.6556	.6551
5	.7500	.7495	.7491	.7494	.7489
6	.8125	.8120	.8116	.8119	.8114
7	.9062	.9057	.9053	.9056	.9051
8	1.0000	.9995	.9991	.9994	.9989
9	1.0937	1.0932	1.0928	1.0931	1.0926
10	1.1875	1.1870	1.1866	1.1869	1.1864
12	1.4375	1.4370	1.4366	1.4369	1.4364
14	1.5625	1.5620	1.5616	1.5619	1.5614
16	1.7500	1.7495	1.7491	1.7494	1.7489

MISALIGNMENT SPECIFICATIONS

The angle of misalignment in a spherical bearing is calculated somewhat differently from that of the rod end because the housing is not spherical. There are three different types of mountings in which these bearings may be used as shown, and the angle of misalignment is governed by the type of mounting adopted.

Shown below are the common mountings for spherical bearings and the corresponding formula for calculating the angle of misalignment.

SPHERICAL BEARING PART NUMBER	MAXIMUM MISALIGNMENT (+/- DEGREES)		
	b ₁	b ₂	b ₃
LS			
3	9.0	16.5	34.5
4	8.0	14.5	29.0
5	9.0	14.0	30.0
6	8.0	12.5	27.0
7	6.5	11.0	25.0
8	7.5	12.5	23.0
10	8.0	12.0	23.0
12	9.0	15.0	27.0
16	6.5	10.0	25.0
19	6.0	8.5	23.5
24	5.0	7.0	23.0
30	5.0	7.0	25.0
LSS, LHA, LHB, LHSS, COM, COS, LHSSE, LHSSV			
2	8.5	13.5	28.0
3	7.0	11.0	29.5
4	9.0	13.0	30.0
5	8.0	12.0	26.0
6	7.5	10.5	23.5
7	6.5	9.5	20.5
8	7.0	10.0	20.0
9	7.5	10.0	20.0
10	7.0	9.0	19.0
12	7.0	9.0	21.0
14	7.0	9.0	16.0
16	7.5	9.5	16.0
LH D			
16	6.5	8.5	26.0
19	6.0	8.0	25.5
20	6.0	8.0	23.0
24	6.0	8.0	21.0
28	6.0	8.0	19.0
32	6.0	8.5	19.0

Reference Letters

B = Bore of ball
 C = Chamfer on outer race
 D = Head diameter or diameter of outer race
 E = Ball diameter
 H = Housing width
 $\sqrt{V} = \sqrt{(D - 2C)^2 + H^2}$
 W = Ball width

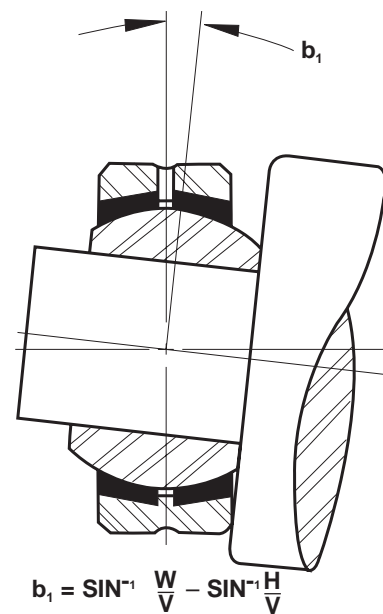

$$b_1 = \sin^{-1} \frac{W}{\sqrt{V}} - \sin^{-1} \frac{H}{\sqrt{V}}$$

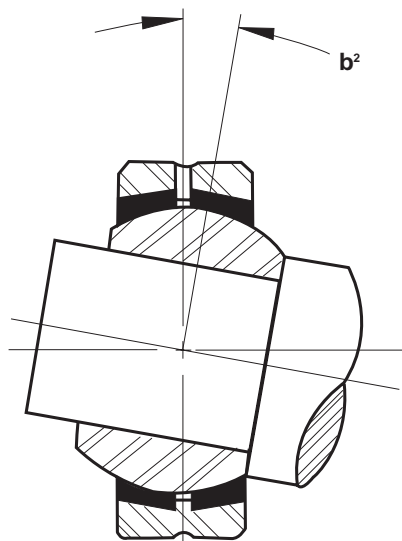

$$b_2 = \sin^{-1} \frac{W}{E} - \sin^{-1} \frac{H}{E}$$

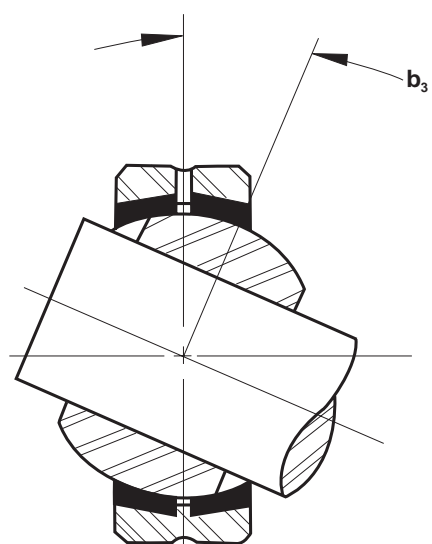

$$b_3 = \cos^{-1} \frac{B}{E} - \sin^{-1} \frac{H}{E}$$

General Information

Sleeve Bearings

Sleeve Bearings

Heim manufactures sleeve bearings in a wide range of materials and sizes for industrial, agricultural, and aerospace applications. Pages 52 and 53 describe two standard series of self-lubricating bearings that utilize UNIFLON® Type E liner material. This liner meets the requirements of SAE-AS81820 (formerly MIL-B-81820). In addition to these standard plain and flanged series, Heim designs and manufactures "specials" to meet specific customer requirements. Working either from a drawing, application description or sample part, Heim also applies UNIFLON® liners to customer supplied bearings.



Lined Sleeve Bearings (Bushings) - Characteristics

UNIFLON® liners in sleeve bearings eliminate the need for lubricating the bearings during their useful life. The UNIFLON® liner is a cost effective solution to many design problems where lubrication is impractical or undesirable. UNIFLON® lined sleeve bearings are ideal for applications where periodic shock loads or vibrations are encountered. Heim's new Type E liner is recommended for sleeve bearing applications where temperatures range from -65°F to 350°F. UNIFLON® liners are highly resistant to most chemical solvents encountered in bearing applications. UNIFLON® lined sleeve bearings have a lower coefficient of friction than metal-to-metal lubricated bearings. For additional information on UNIFLON® liner characteristics see page 54. You are encouraged to consult Heim's engineering department for recommendations on specific application problems.

Shaft Data

An important factor influencing the life of UNIFLON® lined sleeve bearings is the condition of the mating shaft. It is recommended that the shaft have a surface finish of 8 RMS or better and a minimum surface hardness of Rc 40. Commonly preferred shaft materials are hardened corrosion resistant steels, hard anodized aluminum and any metal accepting hard chrome or nickel plate. The mating component should be designed such that there are not sharp edges which could damage the liner during assembly of the sleeve bearing. Cross binding or edge loading on the bearing should be avoided.

Design Inquiry

To request an engineering design on a specific application, submit either a drawing or sketch or submit the pertinent information. All requests will receive prompt design engineering attention and follow-up.

Military Series (M81934/1) Plain Self-Lubricating

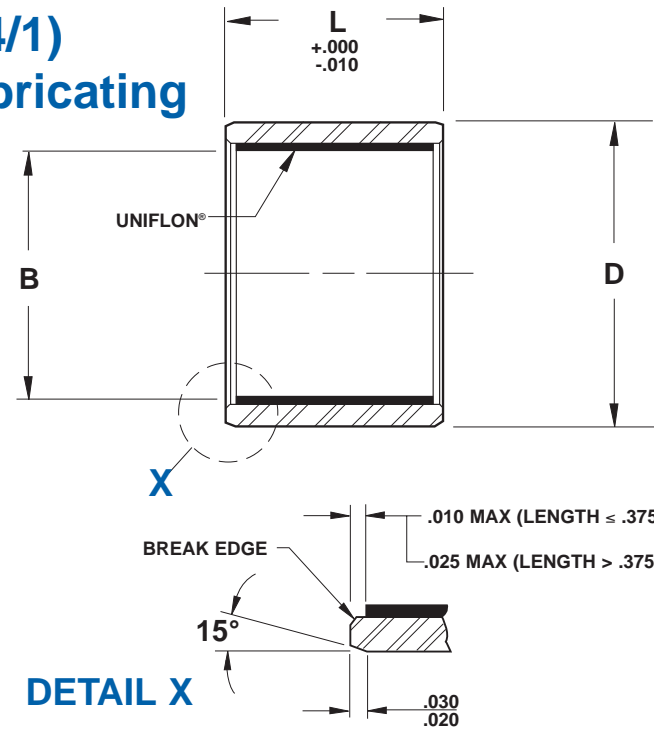

Series PBE

BASIC HEIM NUMBER	DIMENSIONS IN INCHES				WEIGHT LB/IN (REF) L=1.000	
	BORE NOMINAL SIZE	BORE B	OUTSIDE DIAMETER D			
			+ .0000 - .0010	ALUM + .0005 - .0005	CRES + .0000 - .0005	ALUM
PBE04	1/4	.2515	.3760	.3760	.006	.016
PBE05	5/16	.3140	.4386	.4386	.007	.019
PBE06	3/8	.3765	.5012	.5012	.008	.022
PBE07	7/16	.4390	.5638	.5638	.009	.025
PBE08	1/2	.5015	.6265	.6265	.011	.028
PBE09	9/16	.5640	.6892	.6892	.012	.031
PBE10	5/8	.6265	.8142	.8142	.021	.056
PBE11	11/16	.6890	.8767	.8767	.022	.060
PBE12	3/4	.7515	.9393	.9393	.024	.065
PBE14	7/8	.8765	1.0645	1.0645	.028	.075
PBE16	1	1.0015	1.1898	1.1898	.031	.084
PBE18	1 1/8	1.1265	1.3148	1.3148	.035	.094
PBE20	1 1/4	1.2515	1.4398	1.4398	.038	.103
PBE22	1 3/8	1.3765	1.5648	1.5648	.041	.113
PBE24	1 1/2	1.5015	1.7523	1.7523	.062	.171
PBE26	1 5/8	1.6265	1.8773	1.8773	.067	.183
PBE28	1 3/4	1.7515	2.0023	2.0023	.071	.196
PBE32	2	2.0015	2.2523	2.2523	.081	.222

Sleeve: "A": Aluminum alloy
Anodize or Chemical film treatment
"C": 17-4PH Stainless steel, heat treated

Liner: Self-lubricating "E" UNIFLON® per SAE-AS81820 (formerly MIL-B-81820)

NOTES

- Must add material code and length code to basic Heim part number to complete product identification when ordering
Material Code: "A" for Aluminum
"C" for CRES
Length Code: in multiples of 1/32 inches (Refer to "L" on the drawing)
EXAMPLE: PBE04A08 (M81934/1-04A008)
1/4 inch bore, Aluminum, 1/4 inch long
- For liner specification, see page 54
- Heim is qualified to supply this product and all variations to SAE-AS81934 (formerly MIL-B-81934)

Military Series (M81934/2) Flanged Self-Lubricating

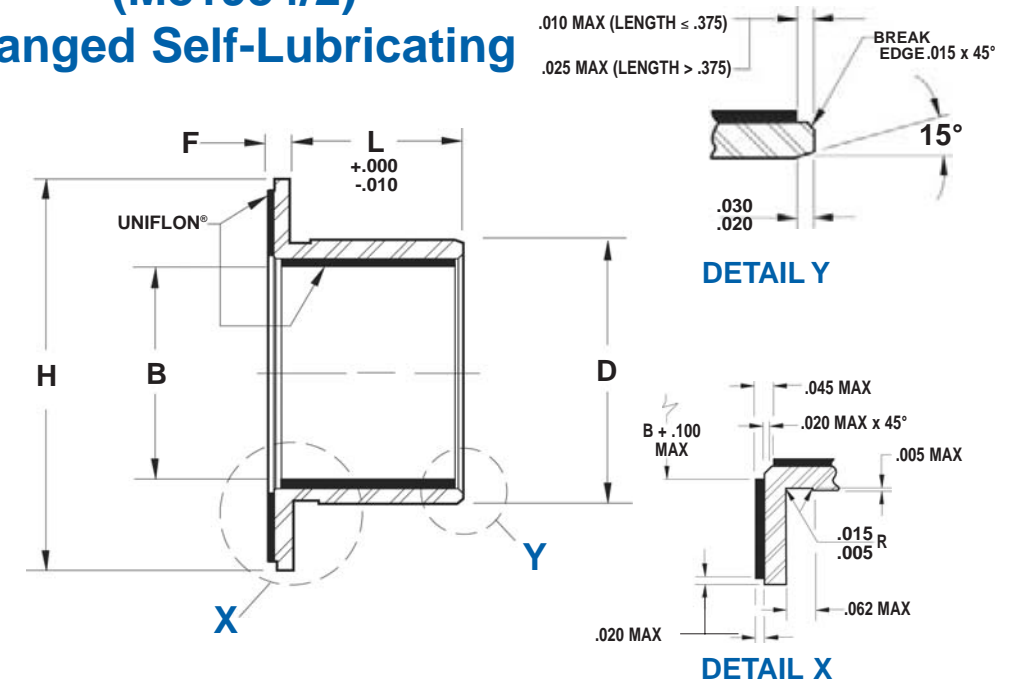

Series FBE

BASIC HEIM NUMBER	DIMENSIONS IN INCHES						SLEEVE WEIGHT LB/IN (REF) L=1.000		FLANGE WEIGHT LBS (REF)	
	BORE NOMINAL SIZE	BORE B	SHOULDER DIAMETER D		FLANGE WIDTH F	FLANGE DIAMETER H				
			+ .0000 - .0010	ALUM + .0005 - .0005			CRES + .0000 - .0005	+ .0000 - .0050	+ .000 - .020	ALUM
FBE04	1/4	.2515	.3760	.3760	.0625	.750	.006	.016	.002	.006
FBE05	5/16	.3140	.4386	.4386	.0625	.812	.007	.019	.003	.007
FBE06	3/8	.3765	.5012	.5012	.0625	.875	.008	.022	.003	.007
FBE07	7/16	.4390	.5638	.5638	.0625	.937	.009	.025	.003	.008
FBE08	1/2	.5015	.6265	.6265	.0625	1.000	.011	.028	.003	.009
FBE09	9/16	.5640	.6892	.6892	.0625	1.125	.016	.031	.004	.011
FBE10	5/8	.6265	.8142	.8142	.0625	1.250	.021	.056	.005	.014
FBE11	11/16	.6890	.8767	.8767	.0625	1.375	.022	.060	.006	.016
FBE12	3/4	.7515	.9393	.9393	.0625	1.500	.024	.065	.007	.020
FBE14	7/8	.8765	1.0645	1.0645	.0625	1.625	.028	.075	.008	.022
FBE16	1	1.0015	1.1898	1.1898	.0625	1.750	.031	.084	.009	.024
FBE18	1 1/8	1.1265	1.3148	1.3148	.0937	1.875	.035	.094	.015	.041
FBE20	1 1/4	1.2515	1.4398	1.4398	.0937	2.000	.038	.103	.016	.045
FBE22	1 3/8	1.3765	1.5648	1.5648	.0937	2.125	.041	.113	.017	.048
FBE24	1 1/2	1.5015	1.7523	1.7523	.0937	2.250	.062	.171	.018	.051
FBE26	1 5/8	1.6265	1.8773	1.8773	.0937	2.375	.067	.183	.020	.055
FBE28	1 3/4	1.7515	2.0023	2.0023	.0937	2.500	.071	.196	.021	.058
FBE32	2	2.0015	2.2523	2.2523	.0937	2.750	.081	.222	.023	.065

Sleeve: "A": Aluminum alloy
Anodize or Chemical film treatment
"C": 17-4PH Stainless steel, heat treated

Liner: Self-lubricating "E" UNIFLON® per SAE-AS81820 (formerly MIL-B-81820)

NOTES

- Must add material code and length code to basic Heim part number to complete product identification when ordering
Material Code: "A" for Aluminum
"C" for CRES
Length Code: in multiples of 1/32 inches (Refer to "L" on the drawing)
EXAMPLE: PBE04A08 (M81934/1-04A008)
1/4 inch bore, Aluminum, 1/4 inch long
- For liner specification, see page 54
- Heim is qualified to supply this product and all variations to SAE-AS81934 (formerly MIL-B-81934)

Technical Data

Self-Lubricating Bearings

UNIFLON® - Self-Lubricating Fabric Liners

To meet the increasing technical demands on self-lubricating bearings, Heim has developed UNIFLON® Type E, a new and improved liner material. Heim's Type E is qualified to procurement specification SAE-AS81820 (formerly MIL-B-81820).

UNIFLON® Type E is unique in the family of teflon type bearing material. Type E is a low coefficient of friction composite of three materials. Most composite bearing materials consist of one layer of low coefficient of friction material usually PTFE fiber, layered or interwoven with either a highly abrasive fabric such as fiberglass, or a low-load bearing fabric such as dacron, coated with resin. Type E combines a low coefficient of friction, high tensile, high compressive strength fabric with chemically bonded teflon fiber to form the Type E matrix.

Why UNIFLON® TYPE E?

UNIFLON® Type E liner is recommended over other bearing materials for the following reasons.

1. High PTFE fiber content. PTFE has the lowest coefficient of friction of known materials today.
2. The bonding material is a polyallomer consisting of two polymers. One polymer provides adhesive properties. The second polymer provides the correct degree of elasticity.
3. The backing or basic high strength-fabric in Type E has an inherent coefficient of friction only slightly higher than PTFE (.019).

Where are UNIFLON® Type E Bearings used?

Type E bearings are designed for use in low surface speed high unit loading where metal to metal is limited or non-desirable. Type E bearings are available with ratings in high static unit loads up to 60,000 psi. For specific radial and dynamic load ratings on Type E bearings, consult the Heim engineering department. UNIFLON® Type E can be used with many combinations of hardened steel, aluminum, titanium and plated surfaces, in many environments, and in temperatures -100°F to 350°F.

Type "VV" Liner

For less demanding or higher temperature applications, Heim recommends its Type "VV" liner. The higher temperature Type "VV" carbon filled liner is particularly suited for high frequency and low load applications in temperatures from -65°F to 500°F.

General Information

Commercial Series UNIBAL® Ball Bearings

Heim's UNIBAL® ball bearings offer many of the performance advantages of precision ground bearings at unground bearing prices. Heim's unique, full complement, deep groove design makes this bearing an ideal replacement for costly precision

ground bearings in high load, low speed applications. Burnished races provide smooth operation. Heim UNIBAL® ball bearings may be used as an economical upgrade from conventional unground ball bearings where increased precision and smoothness are required.

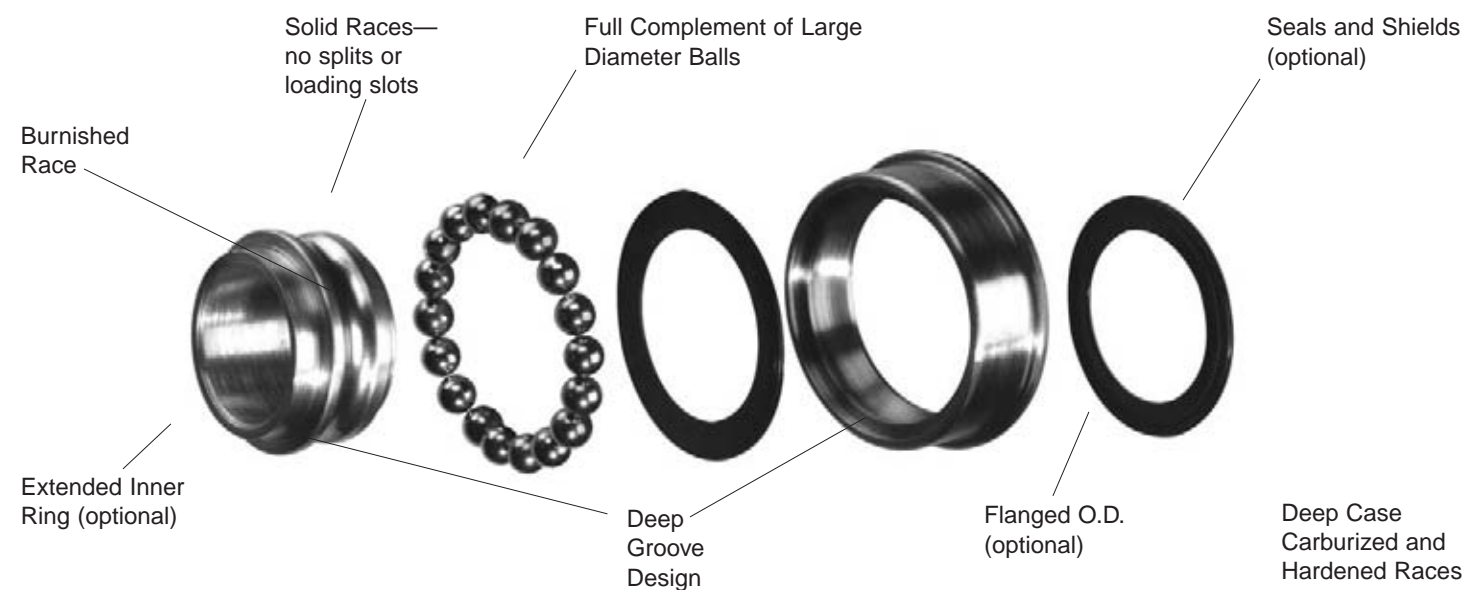

Long Life and High Loads

Burnished races uninterrupted by splits or loading slots, a full complement of large diameter balls, and deep carburized and hardened raceways give the Heim UNIBAL® ball bearing superior ability to handle high loads and provide longer service life.

Thrust Loads

Heim's unique design and assembly method provides deep ball grooves in both races and no loading slots, yielding greater ability to accommodate thrust loads.

Smooth Operation

The burnished races of the Heim ball bearings provide far smoother operation than other unground ball bearings. This feature may allow a Heim design to be used in place of precision ground bearings in many applications.

Easy Mounting

Optional flanged O.D.s are available to simplify housing design and mounting. Heim UNIBAL® ball bearings are also available with extended inner rings to allow clevis mounting.

Sealing

Shields and seals are available as options to retain lubricant and exclude contamination.

Do you require a special design for either the inner or outer race? Please contact your local RBC Sales Engineer or Customer Service (800.390.3300) to tap into over 30 years of design and manufacturing experience.

Sample Applications:

- wheels**
- casters**
- ammunition loaders**
- textile machines**
- door closers**
- power tools**
- conveyors**
- wheelchairs**
- pulleys**
- lift mechanisms**

Coefficient of Friction vs. Temperature

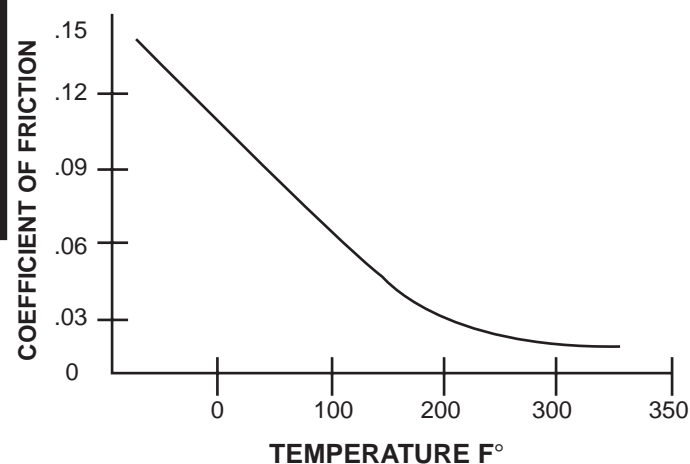

The chart above shows the coefficient of friction of UNIFLON® Type E liner and how this low friction fabric dramatically improves with increasing temperature.

Wear vs. Oscillations

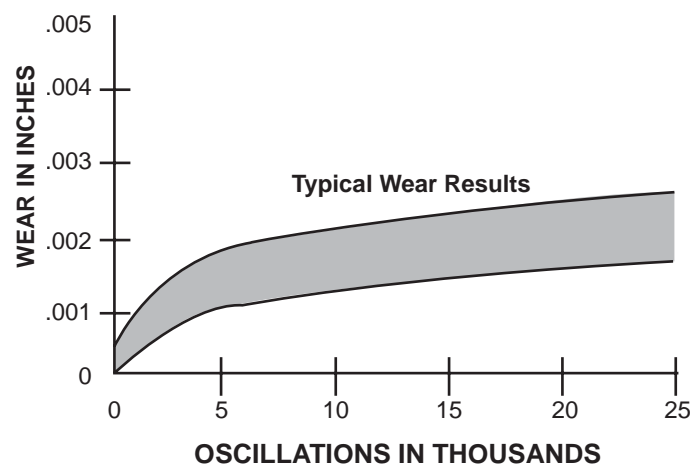

This chart shows a typical wear pattern of UNIFLON® Type E liner and how it varies with the number of oscillations.

Commercial Series

Plain Ball Bearing

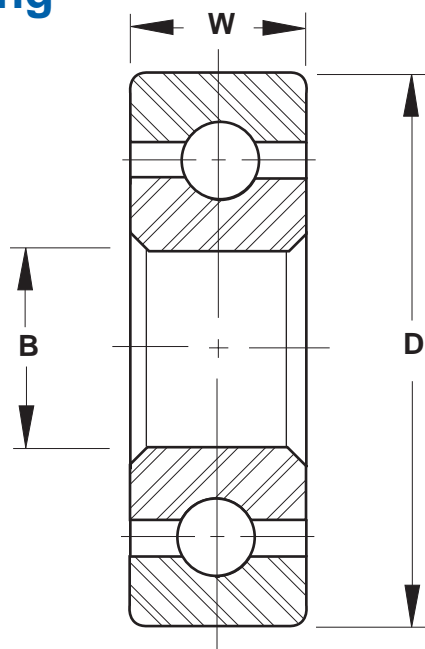

Series R

BALL BEARING NUMBER	BORE B	OUTSIDE DIAMETER D	WIDTH W	BALLS		LOAD CAPACITY IN LBF				
						REVOLUTIONS PER MINUTE				
						50	100	300	600	1000
R385	3/16	1/2	5/32	11	3/32	120	95	50	35	20
R3106	3/16	5/8	3/16	10	1/8	180	140	75	55	30
R4118	1/4	11/16	1/4	12	1/8	225	175	90	65	40
R5148	5/16	7/8	1/4	15	1/8	255	200	105	75	45
R6148	3/8	7/8	1/4	16	1/8	270	220	110	80	50
R514.510	5/16	29/32	5/16	13	5/32	340	270	135	100	60
R614.510	3/8	29/32	5/16	13	5/32	340	270	135	100	60
R61610	3/8	1	5/16	14	5/32	360	280	145	110	65
R71610	7/16	1	5/16	14	5/32	360	280	145	110	65
R6178	3/8	1 1/16	1/4	15	5/32	375	290	155	115	65
R7178	7/16	1 1/16	1/4	15	5/32	375	290	155	115	65
R61812	3/8	1 1/8	3/8	16	5/32	390	310	165	120	70
R71812	7/16	1 1/8	3/8	16	5/32	390	310	165	120	70
R81812	1/2	1 1/8	3/8	16	5/32	390	310	165	120	70
R82214	1/2	1 3/8	7/16	17	3/16	560	450	230	170	100
R102214	5/8	1 3/8	7/16	17	3/16	560	450	230	170	100
R122214	3/4	1 3/8	7/16	18	3/16	600	480	245	180	110
R82414	1/2	1 1/2	7/16	13	1/4	800	620	325	240	145
R102414	5/8	1 1/2	7/16	13	1/4	800	620	325	240	145
R102612	5/8	1 5/8	3/8	15	1/4	880	700	350	260	160
R122612	3/4	1 5/8	3/8	15	1/4	880	700	350	260	160
R122818	3/4	1 3/4	9/16	16	1/4	900	730	375	275	170
R143016	7/8	1 7/8	1/2	17	1/4	950	750	390	280	175
R143216	7/8	2	1/2	19	1/4	1050	820	430	310	180
R163216	1	2	1/2	19	1/4	1050	820	430	310	180

Outer Ring: Carbon steel, case hardened

Inner Ring: Carbon steel, case hardened

Balls: Carbon steel, case hardened

Seals: Synthetic rubber, if required

Shields: Steel, if required

NOTES

- Check with factory for product availability
- Add letter "P" to suffix to indicate one seal. Example: RF102214P
- Add letters "PP" to suffix to indicate two seals. Example: RF102214PP
- Add letters "MP" to suffix to indicate mechanical shield. Example: RF102214MP

Commercial Series

Flanged Ball Bearing

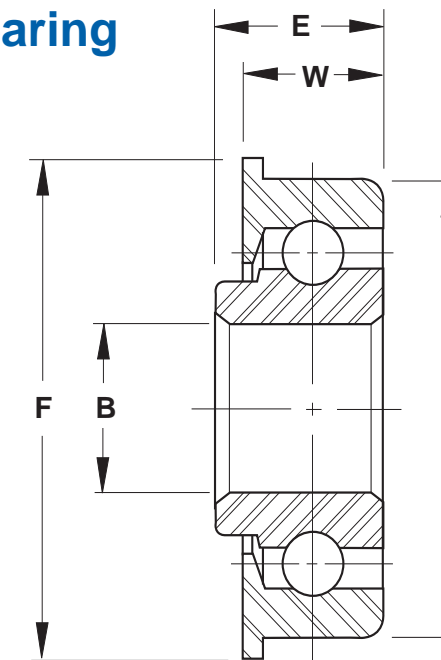

Series RF

BALL BEARING NUMBER	BORE B	OUTSIDE DIAMETER D	WIDTH W	FLANGE DIAMETER F	OVERALL WIDTH E	BALLS		LOAD CAPACITY IN LBF				
								REVOLUTIONS PER MINUTE				
								50	100	300	600	1000
RF3106	3/16	5/8	3/16	3/4	1/4	10	1/8	180	140	75	55	30
RF4118	1/4	11/16	1/4	25/32	5/16	12	1/8	225	175	90	65	40
RF5148	5/16	7/8	1/4	1	5/16	15	1/8	255	200	105	75	45
RF6148	3/8	7/8	1/4	1	5/16	16	1/8	270	220	110	80	50
RF514.512	5/16	29/32	3/8	1	7/16	13	5/32	340	270	135	100	60
RF614.512	3/8	29/32	3/8	1	7/16	13	5/32	340	270	135	100	60
RF61712	3/8	1 1/16	3/8	1 3/16	7/16	15	5/32	375	290	155	115	65
RF71712	7/16	1 1/16	3/8	1 3/16	7/16	15	5/32	375	290	155	115	65
RF61812	3/8	1 1/8	3/8	1 1/4	7/16	16	5/32	390	310	165	120	70
RF71812	7/16	1 1/8	3/8	1 1/4	7/16	16	5/32	390	310	165	120	70
RF81812	1/2	1 1/8	3/8	1 1/4	7/16	16	5/32	390	310	165	120	70
RF82214	1/2	1 3/8	7/16	1 1/2	1/2	17	3/16	560	450	230	170	100
RF102214	5/8	1 3/8	7/16	1 1/2	1/2	17	3/16	560	450	230	170	100
RF122214	3/4	1 3/8	7/16	1 1/2	1/2	18	3/16	600	480	245	180	110
RF82414	1/2	1 1/2	7/16	1 5/8	1/2	13	1/4	800	620	325	240	145
RF102414	5/8	1 1/2	7/16	1 5/8	1/2	13	1/4	800	620	325	240	145
RF122414	3/4	1 1/2	7/16	1 5/8	1/2	16	7/32	720	580	300	220	130
RF102616	5/8	1 5/8	1/2	1 3/4	9/16	15	1/4	880	700	350	260	160
RF122616	3/4	1 5/8	1/2	1 3/4	9/16	15	1/4	880	700	350	260	160
RF102816	5/8	1 3/4	1/2	1 7/8	9/16	16	1/4	900	730	375	275	170
RF122816	3/4	1 3/4	1/2	1 7/8	9/16	16	1/4	900	730	375	275	170
RF103016	5/8	1 7/8	1/2	2	9/16	17	1/4	950	750	390	280	175
RF163016	1	1 7/8	1/2	2	9/16	18	1/4	1000	800	410	300	185
RF143216	7/8	2	1/2	2 1/8	9/16	19	1/4	1050	820	430	310	190
RF163216	1	2	1/2	2 1/8	9/16	19	1/4	1050	820	430	310	190

Outer Ring: Carbon steel, case hardened

Inner Ring: Carbon steel, case hardened

Balls: Carbon steel, case hardened

Seals: Synthetic rubber, if required

Shields: Steel, if required

NOTES

- Check with factory for product availability
- Add letter "P" to suffix to indicate one seal. Example: RF102214P
- Add letters "PP" to suffix to indicate two seals. Example: RF102214PP
- Add letters "MP" to suffix to indicate mechanical shield. Example: RF102214MP

Special Purpose Series

Extra Capacity Ball Bearing

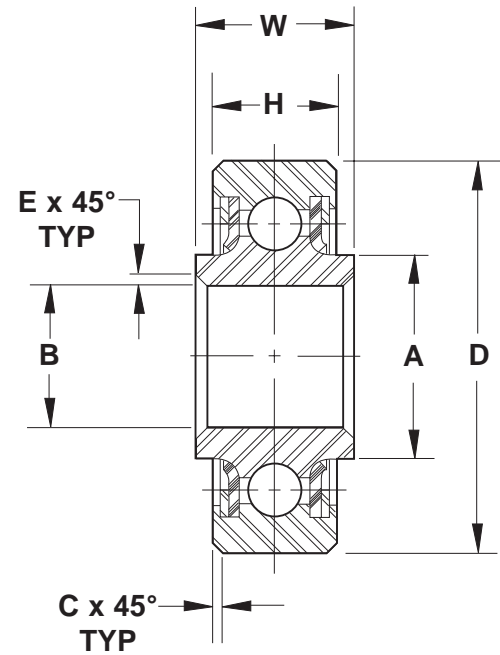

Series HK A

BALL BEARING NUMBER	BORE	OUTSIDE DIAMETER	WIDTH OUTER RING	WIDTH INNER RING	CORNER OUTER RING	CORNER INNER RING	SHOULDER DIAMETER INNER RING	BALLS		LOAD CAPACITY		APPROX WEIGHT LBS
	B	D	H	W	C	E	A	NO	DIA	RADIAL LBF	THRUST LBF	
HK3A	.1900	.6250	.234	.297	.016	.005	.297	10	1/8	1,560	700	0.01
HK4A	.2500	.7500	.219	.281	.016	.005	.340	12	1/8	1,880	900	0.02
HK5A	.3125	.8125	.234	.297	.016	.015	.415	14	1/8	2,190	1,000	0.02
HK6A	.3750	.8750	.250	.313	.016	.015	.483	16	1/8	2,500	1,100	0.03
HK8A	.5000	1.1250	.313	.375	.016	.015	.615	16	5/32	3,910	1,700	0.05
HK10A	.6250	1.3750	.344	.406	.032	.015	.740	14	7/32	6,700	3,000	0.08
HK12A	.7500	1.6250	.375	.437	.032	.015	.915	15	1/4	9,380	4,100	0.13
HK16A	1.0000	2.0000	.438	.500	.032	.015	1.230	19	1/4	11,900	5,200	0.22
HK20A	1.2500	2.2500	.438	.500	.032	.015	1.490	22	1/4	13,800	6,100	0.26

Outer and Inner Rings: Chrome steel, heat treated with protective coating for corrosion resistance on all surfaces exposed after installation

NOTES

1 Check with factory for product availability

Balls: Chrome steel, heat treated

Seals: Synthetic rubber

Shields: Steel, with protective coating for corrosion resistance

Ball Bearing Applications

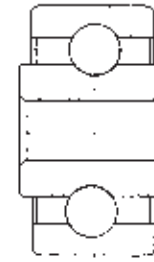

Cam Follower: High load capacity at low speed.



Sliding Window: Outer race serves as a pulley eliminating a component.

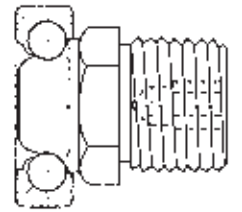

Door Closer: Unitized design allows for easy installation.

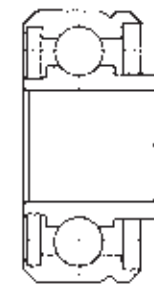

Cargo Roller: Economical replacement for precision bearing.



Radial Arm Saw: Outer race rides in a track to provide guidance.

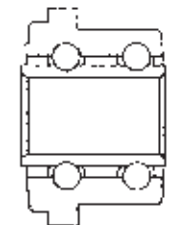

Coin Changer: Double row design with soft races to allow the bearing to be staked in place.



Crane Trolley: Ball bearing design provides axial load capability.



Tractor Wheel: Unbroken races provide strength and durability.

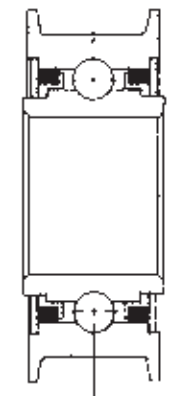

Textile Loom: Integral idler pulley and positive sealing economical replacement.



A special flanged ball bearing with a knurled O.D. which offers superior retention.



A helicopter bearing with special retention provisions for mounting.



This special rod end is for aircraft applications. It utilizes two flush type lubricators for ease of maintenance.



A custom designed double ended bearing may eliminate the need for combining a male and a female rod end in a given application. The bearing may be assembled in customer supplied components.



This aircraft flanged spherical bearing uses a threaded O.D. to provide a retention feature. The threaded O.D. also allows for ease of replacement in the application.



A ball bearing with a concave outer ring for use as a guide roller.



An aircraft series bearing with a keyway. Keyways may also be furnished on female rod ends. Heim has more than 1,000 approvals for aircraft bearing applications.



This special ball bearing with an integral stud in the bore is for ease of customer assembly.



A helicopter swash plate bearing. The PTFE liner in the I.D. of the outer race and the bore of the ball accommodates misalignment and linear motion.



Custom lining is available for customer supplied assemblies.



A suspension bearing for a U.S. Army tank application. The threaded ears provide an easy method of attachment.

Innovation. Commitment. Quality.

RBC has been producing bearings in the USA since 1919. In addition to unique custom bearings, RBC offers a full line of standard industrial and aerospace bearings, including:



Spherical Plain Bearings

Radial, angular contact, extended inner ring, high misalignment. QuadLube®, ImpactTuff®, SpreadLock® Seal, CrossLube®, DuraLube™, and self-lubricating bearings. Available in inch and metric sizes.



Thin Section Ball Bearings

Standard cross sections to one inch. Sizes to 40 inches. Stainless steel and other materials are available. Seals are available on all sizes and standard cross sections. Super duplex configurations. Inch and metric.



Tapered Roller Bearings

Tyson® case-hardened and through-hardened tapered roller bearings. Available in many sizes. Used in Class 8 heavy truck and trailer wheel bearings, gearboxes, and final drive transmissions.



Tapered Roller Thrust Bearings

Case-hardened. Sealed and unsealed for truck, tractor, and construction equipment steer axles, and Class 8 trailer landing gear.



Integrated Assemblies

For robots and other process tool applications. Engineering design assistance. Production volume capacity.



Cam Followers

Standard stud, heavy stud, yoke type, caged roller followers. Patented RBC Roller® cylindrical roller cam followers, HexLube® universal cam followers, airframe track rollers.



Needle Roller Bearings

Pitchlign® caged heavy duty needle roller bearings, inner rings, TJ TandemRoller® bearings for long life.



Self-Lubricating Bearings

Radial, thrust, rod ends, spherical bearings, high temperature, high loads. Available in inch and metric sizes. Fiberglide® self-lubricating bearings.



Airframe Control Bearings

Ball bearing types, self-lubricating types, needle roller track rollers.

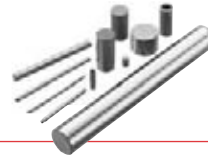

Dowel Pins, Loose Needle Rollers, Shafts

Precision Products dowel pins, loose needle rollers, and shafts.



Commercial Rod Ends

Commercial and industrial, precision, Mil-Spec series, self-lubricating, and aircraft. Sold under the Heim®, Unibal®, and Spherco® names. Available in inch and metric sizes.



Large Ball and Cylindrical Roller Bearings

Ball and cylindrical roller bearings up to 60 in. (1.5 m) O.D. Tapered roller and tapered roller thrust bearings up to 36 in. (9.1 m) O.D. Slewing rings up to 169 in. (4.3 m) O.D.



Ball Bearings

Precision ground, semiground, unground. High loads, long life, smooth operation. Nice® branded products are offered in caged and full complement configurations.



Specials

RBC manufactures many specialty bearings for the aerospace, oil and energy, semiconductor equipment, packaging, transportation, and other industries.