

# Closer Pets

MiDoor+

CP555

# In the box

Don't forget to  
order your MiHub



- A** Inside interior frame
- B** Wall liner adapter\*
- C** UPVC or metal door adapter x2\*
- D** Outside exterior frame
- E** Screws 13mm (1/2") x4
- F** Screws 22mm (7/8") x4
- G** Screws 37mm (1 1/2") x4
- H** Screws 60mm (2 3/8") x4
- I** Screw caps x8
- J** Short foam lining
- K** Long foam lining (for adapter)\*

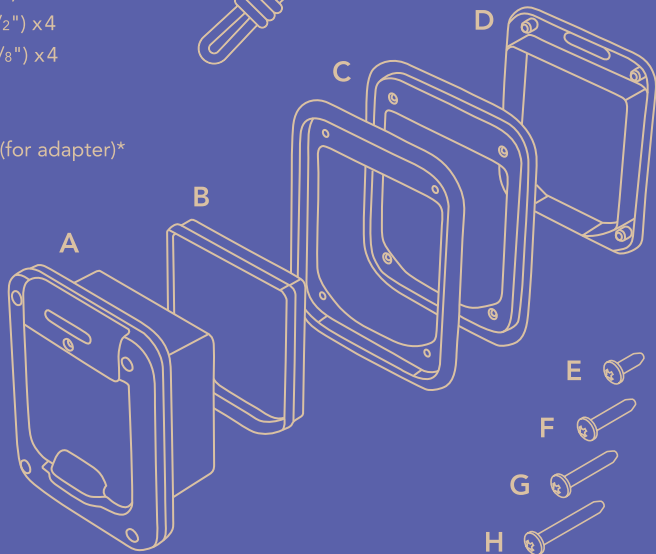
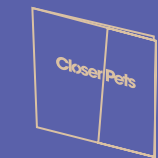

\*May not be required  
for basic install

# Important safety instructions

Read all instructions before installing or using this product.

- Register your purchase online at **closerpets.com** (see Guarantee).
- Do not allow children to play with this product.
- Inspect product regularly for correct operation and damage. Do not use if in doubt.
- This product is designed for use with small pets only.
- The locking system of this cat flap is not intended as a security device.
- This cat flap is not a fire resistant door and must not be used where there is a risk from fire spread.
- The installer of this cat flap is responsible for complying with all relevant building regulations.
- During installation of this cat flap take appropriate care. Follow safety instructions for all tools and wear appropriate personal protective equipment.
- Dispose of all packaging material properly.  
**NOTE:** Plastic bags could cause suffocation – keep away from children and animals.

**SAVE THESE INSTRUCTIONS**



# Inserting batteries

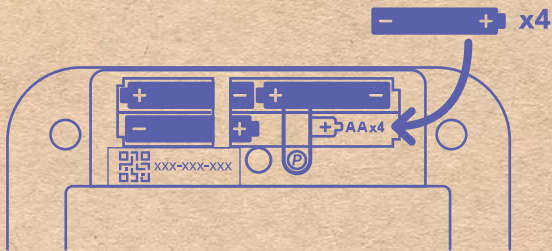

Insert 4 x AA new alkaline batteries matching the + – symbols as shown.

The light will turn white for a few seconds to show the product has powered up. After the light turns off again, the flap is ready for set up.

**Keep the battery cover off during set up with the App** – you will need to use the program button during this process.

 **Keep the battery cover off during set up with the App.**



# Getting started

## Closer Pets App for MiDoor+

The **Closer Pets App** will take you step by step through setting up your **MiDoor+**

Scan the QR code  
to download the  
Closer Pets App

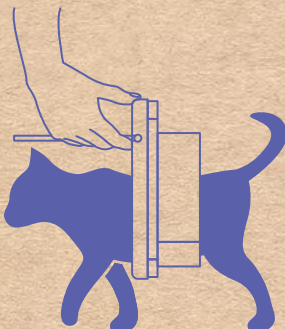

Complete all the steps in pairing before installing your door.

# Setting up

To get the best connection, ensure that your **MiDoor+**, **MiHub** and internet router are close together.

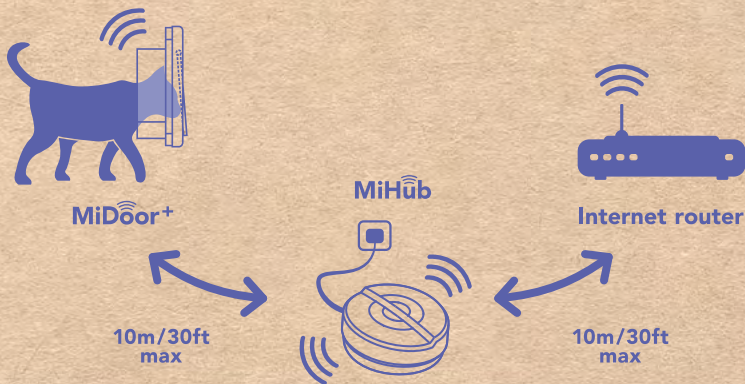

Remove the batteries before starting installation.

This will ensure your **MiDoor+** tunes to your door.

Your **MiDoor+** will remain paired when batteries are removed.

# Installation

## What you'll need

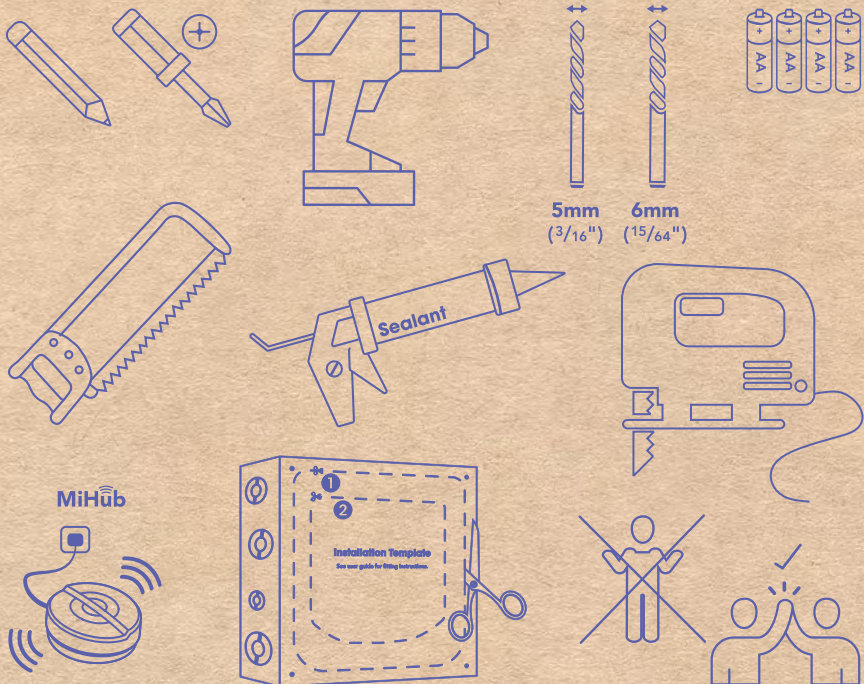



# Installation

## Where do you want to fit your MiDoor+?

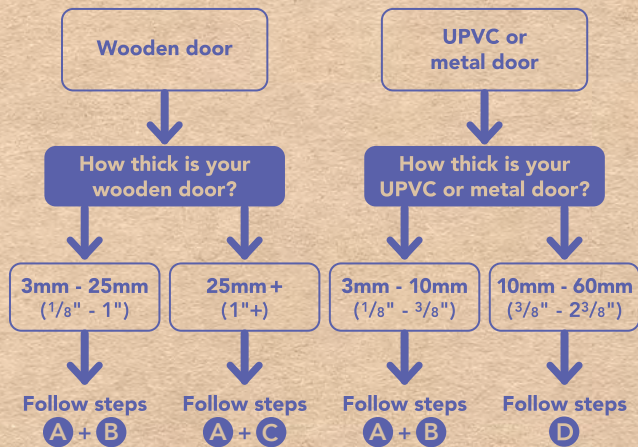

### Does your wooden door have a metal lining?

Metal linings may interfere with the microchip reader. Test whether your door has a metal panel by drilling a small hole in the middle of the intended cat flap location. If your door contains metal, follow the retuning instructions at the end of installation. **If your door contains metal, ensure that you remove the batteries before starting installation.**

Wall or glass window

To purchase the separate 361 Wall/Glass adapter, scan this QR code



**PLEASE NOTE**  
Fitting instructions for glass and walls are not covered in this manual



# A Wooden, UPVC and metal doors

A1

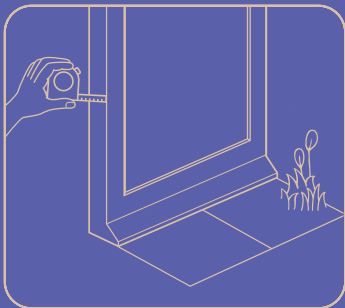

A2

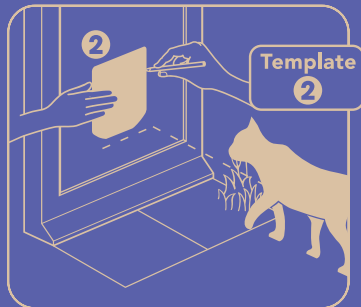

A3

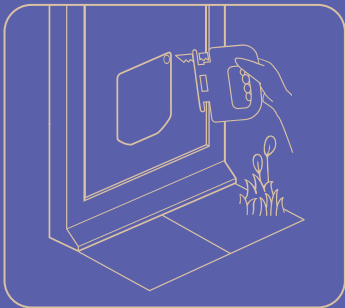

We recommend the bottom of the cut out template is approximately level with your pet's stomach.



**Wooden door**  $t = 3\text{mm}-25\text{mm}$  ( $1/8''-1''$ )

**PUPVC or metal door**  $t = 3\text{mm}-10\text{mm}$  ( $1/8''-3/8''$ )

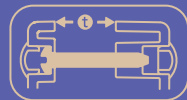

**B1**

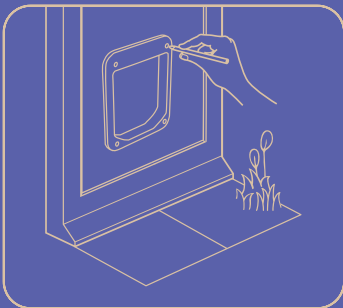

**B2**

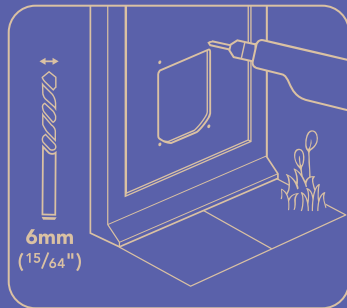

**B3**

If your door is less than 17mm ( $5/8''$ ) thick, cut to the marking on Outside exterior frame (D)

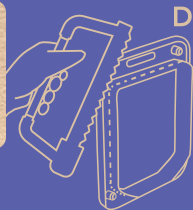

**DO NOT** cut the Inside interior frame (A)

**B4**

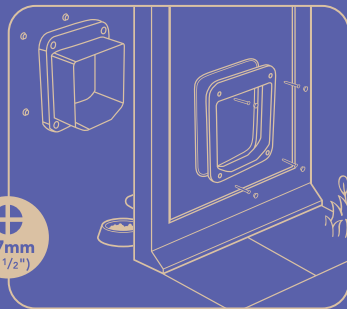



Wooden door  $t = 25\text{mm} + (1'' +)$

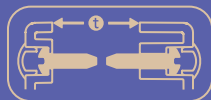

C1

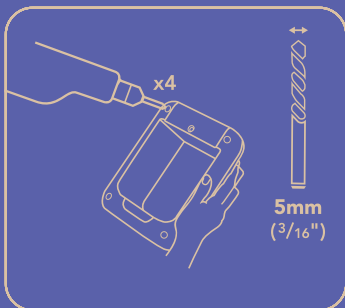

C2

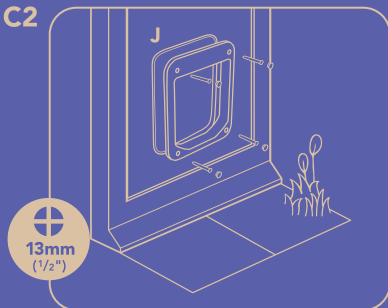

C3

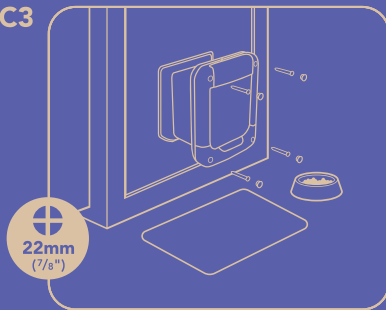



**D****UPVC or metal door****t** = 10mm-60mm ( $\frac{3}{8}$ "- $2\frac{3}{8}$ "")

|  |  |
|--|--|
| <b>t</b>   |  |
| 10 - 32mm ( $\frac{3}{8}$ " - $1\frac{1}{4}$ "") | 37mm ( $1\frac{1}{2}$ "")  |
| 32 - 52mm ( $1\frac{1}{4}$ " - 2"")              | 60mm ( $2\frac{2}{3}$ "")  |
| 52mm + (2" +)                                    | (t) + 19mm ( $2\frac{3}{8}$ "*)  |

\*Not supplied

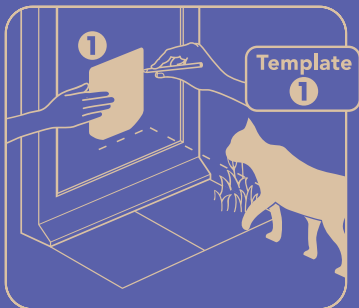
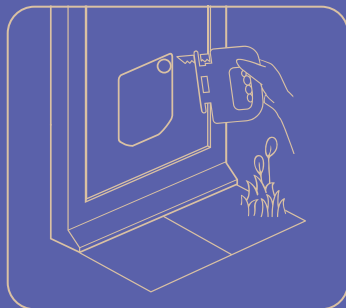
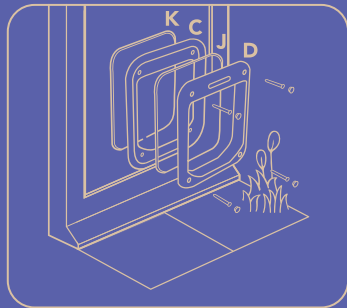
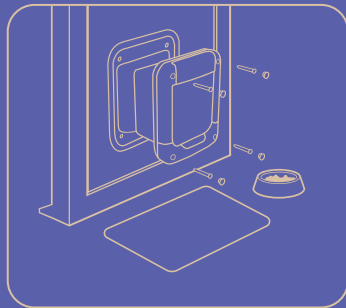
**D1****D2****D3****D4**

# Controls

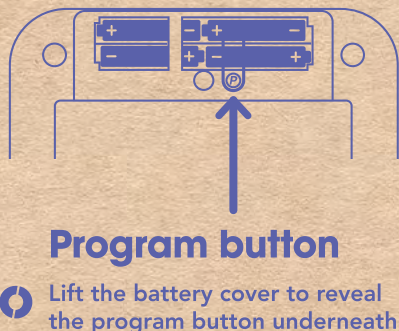
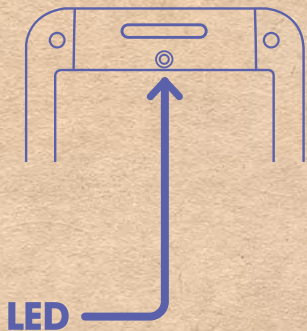

**Amber light** – occurs after the Program button is long pressed once – your **MiDoor+** is tuning and preparing to pair to a pet.

**Green light** – your **MiDoor+** is ready to pair to your pet.

**Flashing green light** – your **MiDoor+** has paired with a microchip.

**Blue light** – occurs after the Program button is long pressed twice – your **MiDoor+** is ready to be connected to your **MiHub** and App.

**Fast flashing red light** – occurs when you hold the Program button for more than 20 seconds – indicates that your **MiDoor+** is about to be reset.

**Slow flashing red light** – the batteries on the product are low and need replacing.

**Flashing red and green light** – more than 10 microchips have been paired – your **MiDoor+** will need to be reset.

# Pet training school

We want to help your pets feel extra comfortable using MiDōor<sup>+</sup>, so we have some useful tips to make using the cat flap second nature for them!



- 1 Start by setting to **Practice Mode** in the Closer Pets App – this setting can be found during Pet Training School or in the Devices page.
- 2 Once the door is unlocked, **prop the door open** and entice your pet through by holding treats on the opposite side of the door. Remember to show them that the flap opens both ways!
- 3 When your pet is ready, remove the prop and **deactivate Practice Mode** in the Device settings in the Closer Pets App.
- 4 **Your pet will need to apply some pressure to the flap before it will start scanning for its microchip**, at which point you'll hear a little 'click' when the door unlocks. You may find this can be startling to your pet at first – keep persevering with treats and toys and they'll soon get the hang of it.



 MiDōor<sup>+</sup> keeps battery usage to a minimum by only scanning when your pet pushes the flap.



# Tips

## Using your MiDōor+

- Do not cut the tunnel of the cat flap.
- Your **MiDōor+** will only open for pets that have been correctly paired. For the best experience, follow the **Closer Pets App**.
- You can pair up to 10 pets to your **MiDōor+**.
- **MiDōor+** is hand wash only using warm soapy water.
- Use non-abrasive cleaning products only to prolong the shiny appearance.
- Do not force your pet through the door – this may scare or discourage them from using it.

## Technical info

- In normal use, good quality alkaline batteries should typically last up to 6 months; we recommend replacing all batteries at the same time.
- When batteries are low, the light on the door will flash red and show in the App.
- All popular batteries are suitable, including rechargeable and 1.5v lithium batteries, however the low battery light will only work with standard alkaline batteries.
- In the case of your **MiDōor+** breaking, spares can be purchased on [closerpets.com](https://www.closerpets.com)

## Optional steps to finish off your installation

### Seal the frame to neaten the edges

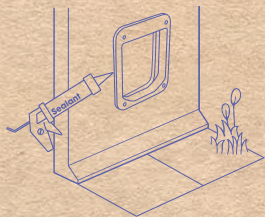

### Use Wall Liners for very thick panels or walls

Purchased separately via the QR code below. These can be assembled with the included wall liner adapter.



# FAQ

## The door doesn't unlock for my pet

- Ensure your pet has been successfully paired with **MiDōor+** and that they appear on the connected list for the product on the Devices page in the **Closer Pets App**.
- Check that there are no obstructions or dirt around the door and that all plastic faces are clean and free of debris. Clean any dirt from the flap and lock areas.
- If you have set **Routines**, your pet will have limited access through your **MiDōor+** during these times. Check the Devices page in the **Closer Pets App** to see your set **Routines**.
- If your door still isn't functioning as expected, you can try rebooting it. Do this by removing the batteries for ten minutes, then reassembling them.

## My pet is scared to go through the door

Hold the flap open and tempt your pet closer using their favourite treats. Go through the steps in the **Pet Training School**.

## My MiDōor+ seems to be locked when I have it set to unlocked

In order to save battery, **MiDōor+** only scans your pet and unlocks when your pet starts putting pressure on the flap. Encourage your pets to push against the flap by putting treats on the rim and on the other side.

## The App says my pet is outside when they are in the house

Although the **MiDōor+** may be the main access point for your pet, there's still a chance that they can bypass it and sneak into an open window or door. If this happens, you can change their location status – this can be found on the **Home** page in the **Closer Pets App**.

## I want to add a pet to my MiDōor+

This can be done through the **Closer Pets App** after connecting your product. Tap the + icon on the top banner to get started.

## Removing paired pets and factory resetting the MiDōor+

Paired pets can only be removed from your **MiDōor+** by factory resetting the product. Pets will then have to be re-added to your **MiDōor+**. To factory reset, press and hold the Program button. Release when the light stops flashing red.

## How do I check that my MiDōor+ is properly connected to the MiHüb?

Your **MiDōor+** will be listed within the **Device** page. If it is displayed as Online then it is properly connected.

## My door seems to be always unlocked

The **MiDōor+** only scans a pet when they come into the home. All pets will be able to leave the home unless you lock it within the App.

# Guarantee

We offer a 1-year standard warranty. However, if you register your **MiDoo<sup>+</sup>** at **[closerpets.com/pages/product-registration](https://www.closerpets.com/pages/product-registration)** within 14 days of your purchase you will receive an additional 2-year warranty and Pet Mate Ltd will guarantee your product for a period of 3 years from the date of purchase.

If you do not have access to a computer, please send details of your purchase with a copy of the receipt along with your name and address to our Customer Services team using the address below and they will be happy to help process this for you.

Please get in touch with Closer Pets Customer Services if you have a problem with your purchase. The guarantee is here to protect you if any defect arises due to faulty materials or manufacture. Any defective items will be repaired or replaced free of charge by Pet Mate Ltd, provided the defect has not been caused by neglect, misuse or normal wear and tear. Your statutory rights are not affected.

To get started, register now by scanning the QR code or by following this link: **[closerpets.com/pages/product-registration](https://www.closerpets.com/pages/product-registration)**



Designed and Manufactured by Pet Mate Ltd, Lyon Road, Hershaw, Surrey KT12 3PU, UK  
Imported to the EU by Closer Pets BV, Newtonlaan 115, 3584 BH Utrecht, The Netherlands  
Imported to North America by Ani Mate, 104A Longview Street, Conroe, TX 77301, USA



Hereby, Pet Mate Ltd declares that this product is in compliance with the essential requirements and other relevant provisions of EU and UK Directives. All Declarations of Conformity (DoC) may be viewed at **[closerpets.com/pages/eu-doc](https://www.closerpets.com/pages/eu-doc)**.



**IMPORTANT:** Dispose of damaged / faulty / end-of-life products in accordance with locally applicable regulations for your country. **UK/EU:** Refer to Terms and Conditions section EU Waste Electrical and Electronic Equipment (WEEE) Directive on **[closerpets.com](https://www.closerpets.com)** for more information.



Register  
your MiDoor+

Additional 2 years warranty



 [closerpets.com](https://closerpets.com)

 [help@closerpets.com](mailto:help@closerpets.com)

55501/01