



# Tank Packages

# Installation Instructions

For Lubricating and Hydraulic Oil Storage and Dispensing

Listed under UL Standard SU2258

1135-001, 1135-002, 1135-003, 1135-004, 1135-005, 1135-006, 1135-007, 1135-008, 1135-009, 1135-010,  
1135-011, 1135-012, 1135-013, 1135-014, 1135-015, 1135-016, 1135-017, 1135-018, 1135-019, 1135-020,  
1135-021, 1135-022, 1135-023, 1135-024, 1135-025, 1135-026, 1135-027, 1135-028, 1135-029, 1135-030,  
1135-031, 1135-032, 1135-033, 1135-034, 1135-035, 1135-036

Meets the requirements of

ANSI/NFPA 31

ANSI/NFPA 30

NFPA 30a

CSA B-139-04

Roth Industries  
USA Contact Info:  
Syracuse, New York 13211  
Toll Free: 888-266-7684  
Fax: 866-462-2914  
Email: [info@roth-usa.com](mailto:info@roth-usa.com)

Balcrank Corporation  
Weaverville, NC 28787  
Toll Free: 800-747-5300  
Fax: 800-763-0840  
Email: [info@balcrank.com](mailto:info@balcrank.com)

# Table of Contents

<b>Before You Begin .....</b>	<b>Page 3</b>
<b>Section 1 - Roth/Balcrank Industries Double Wall Tank.....</b>	<b>Page 4</b>
Construction	
Models and Specifications	
Third Party Testing and Approvals	
Installation Training	
Warranty Terms and Product Registration	
<b>Section 2 - Installation Parts And Accessories.....</b>	<b>Page 8</b>
Parts Supplied with Tank	
Dispensing System Installation Accessories	
<b>Section 3 - Pre-Installation .....</b>	<b>Page 10</b>
Permits and Approvals	
Warnings and Cautions	
Tank Unpacking and Inspection	
<b>Section 4 - General Installation Instructions.....</b>	<b>Page 12</b>
Site Selection	
Locating the Tank	
Tank Base Installation	
Flood and Earthquake Considerations	
Tie Down Kit	
Piping Connections	
Normal and Emergency Venting	
Testing and Inspection	
<b>Section 5 - Hose Reel Base and Hose Reel Instalation.....</b>	<b>Page 18</b>
2" Metal Adaptor	
Hose Reel Base Assembly	
Hose Reel	
<b>Section 6 - Balcrank/Roth Package Start-up &amp; Commissioning.....</b>	<b>Page 22</b>
<b>Section 7 - Completed Installation Review and Warranty Documentation</b>	<b>Page 23</b>
<b>Section 8 - Yearly Maintenance and Troubleshooting.....</b>	<b>Page 24</b>
Yearly Maintenance	
Troubleshooting	
<b>Fill Chart.....</b>	<b>Page 26</b>

# Congratulations on the purchase of your Roth/Balcrank Industries Double Wall Tank

The package is shipped assembled and ready for use. Please follow these instructions for set-up fill and operation of the package.

1. Move the unit to the desired location following the steps listed on pages 10-14 insuring that all steps have been followed.
2. With tank mounted reel packages, Balcrank recommends that the optional tie-down kits be utilized. The Roth double wall tanks are light-weight and if the oil level is low and the hose is pulled too hard, there is a potential for tipping. Please be sure to review the need for these tie-downs for your particular application. For seismic considerations, tie-downs may be required. See pages 14-15.
3. Fill the tank with oil once you have reviewed pages 24-25.
4. Pump/system commissioning instructions can be found on page 22.

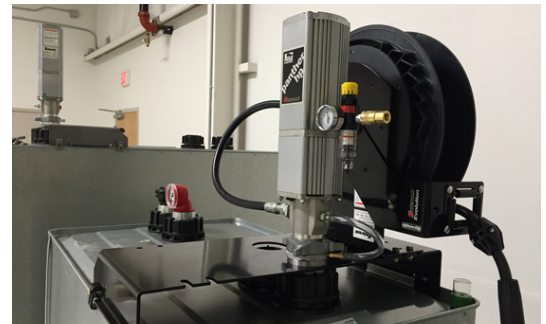

- Pump (available models)
  - o 3:1 Panther
  - o 5:1 Lynx HD
  - o 3:1 Lynx
- Hose Reel (available models)
  - o 1/2 x 30' Evolution
  - o 1/2 x 50' Evolution
  - o 1/2 x 30' Classic
  - o 1/2 x 50' Classic
- Air Filter/Regulator
- Metered Control Handle
  - o 3330-159 DR memory/flex



- Tank level gauge
- Vented fill cap

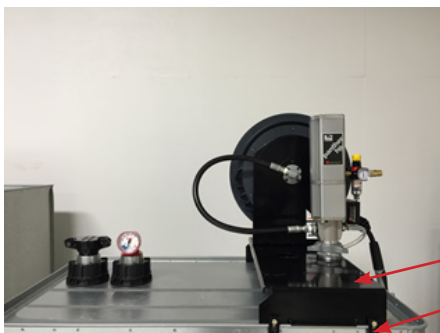

- Pump & Reel mounting base
- Mounting clips

# Section 1 - Roth/Balcrank Industries Double Wall Tank

## Construction

1. The Roth/Balcrank tank packages include a double wall tank (DWT) providing both primary and secondary containment tanks for **diesel fuel, bio-fuels up to B20, and both new and used automotive motor oils.**



2. Our packages provide distinct advantages over common single wall tanks: superior fire protection over most single wall tanks by keeping the oil cooler and therefore less stress on the tank seams, as shown in UL fire tests; the combination of a steel tank encasing a plastic tank protects the fuel oil products, particularly bio-fuels, with the best light and diffusion barrier; when properly secured in place, the double wall tank provides excellent safe oil storage in flood prone locations, a record established in over forty years of use.
3. The primary containment tank is made of high density polyethylene resin and is formed by a rigorously controlled blow molding process. Polyethylene is a material that combines flexibility with very high resistance to the corrosive effects of both acids and water. Acids are found in all fuel oil products and are, in combination with water, the primary cause of steel tank failure. Water is commonly found in fuel oil storage tanks from water vapor, introduced by the vent piping primarily during the emptying of the tank, condensing inside the tank as the air cools when in contact with the cooler oil. The use of polyethylene, with its high resistance to corrosion, essentially eliminates the foremost reason for failure.
4. The secondary containment tank is made with 19 gauge galvanized steel. The use of steel offers strength to resist damage to the inner tank from impacts by other objects, rigidity to support the flexible inner tank, and the ability for electrical grounding of the tank where required by local code. The outer tank sides and bottom are formed from one sheet of steel, which is then shaped to receive the panels used at each end of the tank. The seams are caulked and then rolled in a three step robotic procedure, producing a strong, fluid tight and weld-free joint.

5. Each inner and outer tank is tested for defects and liquid tightness. **The inner tank is pressure tested to 4.35psi.** It is also weighed to make sure it contains the correct amount of material, and finally measured ultrasonically at critical points to verify that it has the required wall thickness. Each sheet of steel for the outer tank is inspected for damage or blemishes that could compromise the galvanized coating. **Once the outer tank is assembled, it is pressure tested to .25 - .30psi to ensure the integrity of its seams.** The inner tank is then placed inside the outer tank, gaskets placed around the four openings of the inner tank, and the outer tank top installed, riveted into place, and its edge rolled. The leak detector, #3 gaskets, plastic and die-cast metal adaptors, cap nuts and dust plugs are then installed, labels affixed, the warranty packet and tank base placed on top of the tank, and finally a protective plastic shrink wrap is put over the top of the completed tank.
  
6. The completed tank has four connections at the top and, unlike a standard steel tank and most other poly tanks, none elsewhere. By eliminating a connection below the oil level in the tank, a potential source of leakage is eliminated. The four connections can be used interchangeably, providing the installer with greater flexibility in accommodating difficult or unusual piping installations.

## **Tank Specifications**

<b>Tank Package Model</b>	<b>165 Gal</b>	<b>275 Gal</b>	<b>400 Gal</b>
Nom. Capacity US gal (liters)	165 (620)	275 (1000)	400 (1500)
Length inches (cm)	29 (74)	51 (130)	64 (163)
Width inches (cm)	28 (72)	30 (76)	30 (76)
Height inches (cm)	61 (155)	54 (137)	68 (173)
Min. Height Req'd inches (cm)	66 (168)	60 (152)	76 (193)
Weight lbs (kg)	132 (60)	208 (94)	333 (151)
Shipping Weight lbs (kg)	143 (65)	230 (104)	358 (162)

## Approximate Footprint for Multiple DWT Installations

Tank Model	165 Gal	275 Gal	400 Gal
2 Tanks Side by Side inches (cm)	29 X 60 (74 X 152)	51 x 63 (130 x 160)	64 x 63 (163 x 160)
2 Tanks Side by Side inches (cm)	29 X 92 (74 X 234)	51 x 96 (130 x 244)	64 x 96 (163 x 244)
2 Tanks Side by Side inches (cm)	29 X 124 (74 X 315)	51 x 129 (130 x 328)	N/A
2 Tanks Side by Side inches (cm)	29 X 156 (74 X 397)	51 x 162 (130 x 411)	N/A
2 Tanks End to End inches (cm)	N/A	N/A	N/A

### **Third Party Testing and Approvals**

1. The primary U.S. code governing fuel oil tank manufacturing and installation is the National Fire Protection Association (NFPA) code, Section 31.
2. The corresponding Canadian code is CSA B-139-09.
3. The primary US Codes governing lube oil storage and dispensing are National Fire Protection Association (NFPA) Section 30 & 30A.
4. The Roth EcoDWT plus 3 has been tested by both the U.S. and Canadian divisions of the Underwriters Laboratories (UL). As a result of passing stringent fire and safety tests, the Roth EcoDWT plus 3 is listed under UL standard SU2258 and each tank bears the UL mark - c UL us.
5. The scope of UL standard SU 2258 extends to tanks intended for installation and use in accordance with ANSI/NFPA 30, the Flammable and Combustible Liquids Code and ANSI/NFPA 30A, the Code for Fuel Dispensing Facilities and Repair Garages.

### **Installation Training**

1. To ensure the highest level of operation and customer satisfaction, Balcrank encourages each installer to receive training in the proper installation of our packages.
2. This training is offered through the network of sales representatives that Balcrank maintains, allowing installers to receive training in their immediate area.

## **Tank Warranty Terms and Product Registration**

1. Under the terms of the warranty, Roth Industries warrants the Product against leakages caused by defects in materials and workmanship for a period of thirty (30) years from the “Start Date”. This warranty is provided by the tank manufacturer.
2. During the first ten (10) years of the warranty period, Roth shall (i) at its discretion, either repair the Product or provide a replacement product of similar size, design and quality, and (ii) pay all labor costs associated with such repair and/or replacement, all of which shall be at Roth’s expense up to a maximum of one thousand (\$1,000) USD in each case. Purchaser shall be responsible for payment of the costs of shipping, freight and insurance on any replacement product, all of which shall be at Purchaser’s expense.
3. In addition, during this first ten (10) year period ONLY, in the event that all conditions contained in the Limited Warranty are otherwise satisfied, Roth shall also reimburse purchaser, up to a maximum amount of US \$2 million, for the costs and expenses incurred by Purchaser for damage to purchaser’s property directly and proximately caused by a leakage of oil from a defective Product.
4. During years eleven (11) through year thirty (30) of the warranty period, Roth shall, at its discretion, either repair the Product or provide a replacement product (or 100% credit towards the purchase price of a replacement product) of similar size, design and quality. Purchaser shall be responsible for payment of all labor costs associated with such repair and/or replacement, as well as the costs of shipping, freight and insurance on any replacement product, all of which shall be at Purchaser’s expense.
5. The warranty period (“Start Date”) begins at the date of installation of the Product as recorded on the warranty card and submitted to Roth after installation. If the warranty card is not submitted, the warranty period (“Start Date”) begins at the date of manufacture of the Product. THIS LIMITED WARRANTY SHALL BE VOID IF THE PRODUCT IS NOT INSTALLED WITHIN TWELVE (12) MONTHS AFTER THE DATE OF SALE BY THE PURCHASER (DISTRIBUTOR) TO THE INSTALLER.
6. Though statements above are a part of the warranty statement, they do not reflect all warranty conditions. Please read the limited warranty certificate to be informed of all conditions and rights.



## Section 2 - Installation Parts and Accessories

### Parts Supplied with Tank

Quantity	Part #	Description
4	-	Threaded Dust Plug
4	833618	Plastic Cap Nut
4	833619	2" NPT Die-Cast Metal Adaptor
4	833620	#3 Gasket
4	833621	Bulkhead Nuts
1	833560	Gauge, Tank Level for 165/275 GAL tanks
1	833561	Gauge, Tank Level for 400 GAL tanks
1	-	Leak Detector
1	-	Installation Packet including Warranty Certificate Forms (2), Parts Check List & Installation Instructions
1	Various	Tank Base

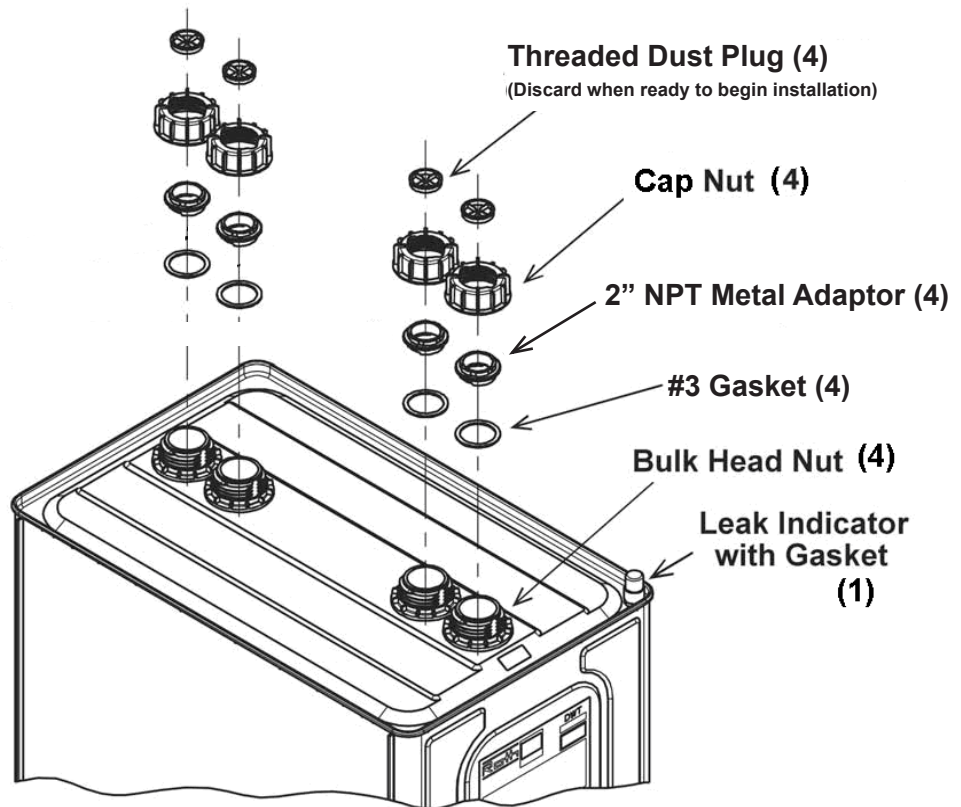



## Dispensing System Installation Accessories

Tank Size	Hose Reel Base w/ Hardware	Tie Down Kit
165 Gal	1136-003 165/275 Gal	1140-001 - order 1
275 Gal	1136-003 165/275 Gal	1140-001 - order 2
400 Gal	1136-004 400 Gal"	1140-002 - order 2

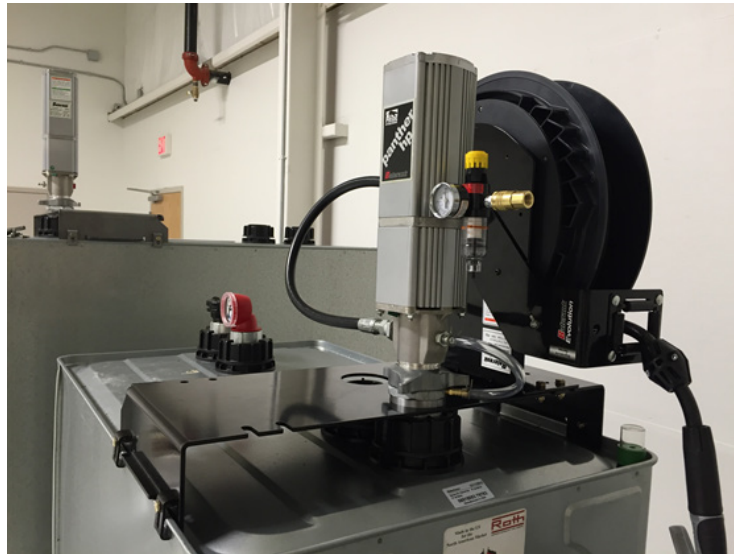

### **Hose Reel Base w/ Hardware**

Lasercut steel base designed to fit atop the Roth EcoDWT Plus 3 tanks. Hardware contains bolts, nuts and washers to fasten base to tank and to fasten hose reel to base.

### **Tie Down Kits**

Used to keep tank and accessories from shifting or tipping over during use. See instructions on page 14 for complete details.

### **2" Metal NPT Adaptors**

Four (4) metal 2" Female NPT adaptors are furnished with the tank

## Section 3 - Pre-Installation

It is very important to read and familiarize yourself with these instructions before installing the tank(s). There are a number of steps that are crucial to a successful installation and to maintaining the warranty.

### Permits and Approvals

Installing a single Roth/Balcrank tank package inside a building is a straightforward process. Nearly all municipalities have codes governing the installation and use of oil tanks. Always consult with the code officers and inspectors before installing a Roth/Balcrank tank packages to be sure you are in compliance with all applicable local codes and have obtained all required permits. Code officers may be unfamiliar with the Roth double wall tank, so time taken in acquainting the officer(s) with the tank's unique advantages and certifications will usually make final approval much easier.

### Warnings and Cautions

To the Distributor:

1. Fully inspect the tank for shipping damage. The tanks are inspected for damage before shipment from the manufacturing facility and must be inspected for shipping damage upon delivery. If damage is found, the shipping company, not Balcrank Corp., must be notified.
2. Do not remove shrink wrap covering unless it will be replaced with similar material.
3. Do not store tanks outside without shrink wrap covering to prevent water seepage into the interstitial space between the two tanks and to prevent the destruction or loss of the supplied warranty materials.
4. Tanks should not be stored outside or uncovered for more than thirty (30) days to prevent UV degradation of plastic materials
5. Confirm that the warranty package is with the tank. It is located on top of the tank under the shrink wrap and easily visible. If it is missing contact Balcrank Corp. for a replacement package.

To the Installer:

1. Do not remove the shrink wrap until the tank has either been moved inside or is ready to have the cover placed on it if an outside installation.
2. Failure to follow the instructions given in this installation manual may:
  - a. Void the tank warranty.
  - b. Compromise the structural integrity of the tank, requiring its replacement.
  - c. Result in personal injury and/or property damage.
  - d. Make the installer liable to penalties under applicable state and local law.

4. Do not install without obtaining appropriate permits and approvals.
5. Always install the Balcrank/Roth package according to applicable building and health codes for oil storage systems.
6. Do not install equipment greater than 10 lbs. (4.5 kg.) directly on the tank connections without external support

## **Tank Unpacking and Inspection**

1. The top and upper portions of the package are covered with shrink wrap plastic designed to keep the top of the tank weathertight. The shrink wrap must be left in place until the tank has been moved inside or is ready to have the cover placed on it if an outside installation. It is transparent, so the tank top and connections can be examined for damage. The base for each tank is shipped on bottom of the tank to protect the fittings during shipping.
2. The tanks are inspected for damage before shipment from the manufacturing facility and must be inspected for shipping damage upon delivery. If damage is found, the shipper, not Balcrank, must be notified.
3. In the course of shipping and handling after the tanks leave the Balcrank, some minor denting and scraping of the tanks may occur. Minor scratches and scrapes on the surface of the galvanized steel outer tank can be easily repaired by cleaning the surface with any common degreaser and then coating the affected area with any zinc bearing paint designed for such repairs. Most hardware and building supply stores will carry one or more brands of galvanizing repair products.
4. Dents of a  $\frac{1}{4}$  inch depth or less above the curved portions of the sides or in the end panels are generally considered minor and will not affect the integrity of the tank. If the deepest part of the dent forms a sharp projection against the inner tank, or if the dent is on or below the curved sides, this can abrade the surface of the inner tank over time and weaken it. **A tank damaged in this way should not be used.**
5. If the rolled seam has been struck and is distorted to the left or right  $\frac{1}{4}$  inch or less, the sealing compound will still be intact. Any seam distorted more than  $\frac{1}{4}$  inch or directly dented in will have the sealing compound compromised and should not be used. Any tank installed with unacceptable dents will not be covered by the warranty.

Contact the Balcrank Corp Technical Service Department if you have any questions concerning dents or scraping on the units. Typically, you will be asked to send pictures of the tank.

## Section 4 - General Installation Instructions

### Site Selection

**The Roth/Balcrank Tank Package must be installed indoors for this application.**

The following standards must be met:

(Always check local building and fire codes for specific requirements in your location.)

- 1. Level surface** - The package has an upright tank having a higher center of gravity than a standard single wall tank. This design allows a smaller footprint than a typical single wall tank. The result is also a taller tank profile, requiring the tank to be installed so that it is plumb to within a ½ inch of vertical, as checked on both an end and a side. If the tank is not plumb the proper alignment of piping connections will prove difficult, especially with the use of expansion kits for multiple tank setups. The accuracy of the fuel gauge and the correct operation of the vent will also be affected. If the tank is more than ½ inch out of plumb, the surface must be leveled with an appropriate leveling compound or the product warranty is void.
- 2. Weight bearing capacity** - Since #2 fuel oil weighs 7.2 lbs/gallon, a model 1000L (275 gal.) tank will hold approximately 1730 lbs when full, which brings the total weight of the tank to about 1900 lbs or just short of a ton. Since the model 1000L has a footprint of 8.3 ft<sup>2</sup>, this means the load bearing surface is carrying about 227 lbs/ft<sup>2</sup>. NFPA 31-7.3 and CSA B-139-09: 7.3.8 have specific requirements for oil tank foundations that must be followed. The base for the Roth DWT requires full contact support under each of the tubular legs to produce a properly stable installation. Use of masonry blocks such as pavers, sidewalk blocks, and cement wall blocks will not provide sufficient support and will void the warranty.
- 3. Minimum clearance** - A minimum of 2 inches of clearance is needed between the Roth/Balcrank tank package and any wall, post, or other permanently installed structural member, support, or barrier. When the tank is filled with oil, its sides could expand horizontally as much as 2 inches, so the clearance is required to prevent contact between, and undue pressure being applied to, either the tank side or the structure next to it. This distance also allows for inspection of the tank sides. CSA B139-09: 7.3.5 states that a minimum clearance of 460 mm (18 in) be made along one side and one end for service accessibility. The tank dimensional tables give the minimum height needed for installation, but it is recommended that there be a minimum clearance over a tank of 2 feet to permit removal and reinstallation of the single use leak detector, if necessary.
- 4. Proper drainage** - Although the Roth/Balcrank tank package outer tank and base are made from galvanized steel with a minimum expected life span of 30 years with normal use, prolonged exposure to water and water-borne salts and/or acids can significantly reduce that life span. It is very important that the tank installation site has good drainage, and that the surface the tank rests on is dry for the majority of the time. Any water from wash areas or water softener units must be directed away from where the tank is located.

## 5. Locating the Tank

1. Make sure the tank package will fit through all doors, stairs, halls, and turns taken to reach its intended placement. The tank cannot be dismantled or otherwise altered to make it fit through smaller spaces and any attempt to do so will destroy its structural integrity as well as void the warranty.
2. Examine the desired tank location for deficiencies in the load bearing surface, such as irregularities, slope, and dampness. If a level pad will be poured on the existing floor, it should extend 6 inches past all exposed sides of the tank.
3. The tank must not be installed closer than 5 feet to the heating appliance (NFPA 31 – 7.5.6) and cannot obstruct access to other utilities' panels, meters, or control valves.
4. Because the connection points of the inner polyethylene tank project above the outer tank top, the DWT must not be installed near a window that will allow exposure to sunlight (UV radiation) on these connections. Although the polyethylene does have limited UV inhibitors in it, prolonged exposure to sunlight can start breaking down the exposed plastic. The same precaution applies to the clear plastic cover on the leak detector.
5. After the site is prepared, remove shrink wrap and other packing materials and thoroughly inspect the tank and accessories for any hidden damage or missing parts. If damaged, contact the freight company.
6. Once the inspection is complete, the installation can begin. Each tank has 4 connection ports on the top. These can be used interchangeably during installation for the various tank fittings, providing maximum flexibility for the planned connections.

The certification label on the tank should be visible after installation.

## **Tank Base Installation**

1. The Roth/Balcrank tank package uses a one piece base assembly, known as a cradle base, for support. This base is shipped on bottom of the tank.
2. The base consists steel tubular "legs" running parallel the full length of the tank with the cradle assembly attached to them. The design of the base requires the legs to be in contact with the floor for their entire length, or distortion and possible failure of the base can occur.
3. Once the site is ready for the tank to be set in place, simply set the base on the floor in the approximate location the tank will be installed and place the tank on the base. There is no need to connect the base to the tank, as it is designed to lock in place when the tank is filled with oil. Once the tank is on the base, the unit can be easily slid to its permanent location, allowing for proper clearances.

**Failure to use the base may result in tank failure and will void the warranty.**

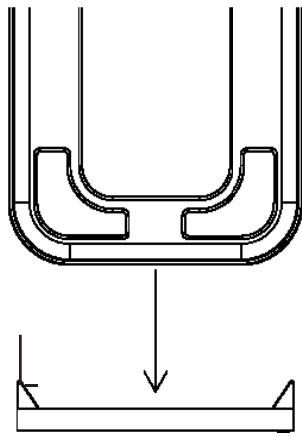

Front, Rear View

Fig 3.1

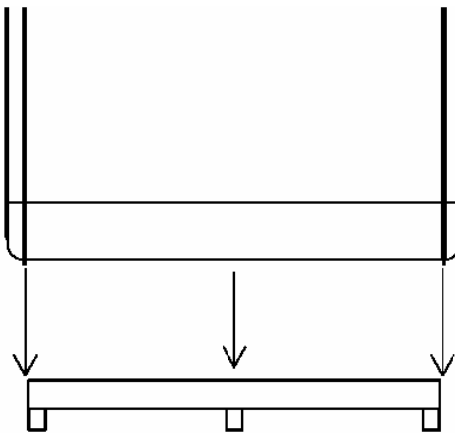

Side View

Fig 3.2

## **Flood and Earthquake Considerations**

1. Always consult local codes and regulations regarding above ground oil storage tank installations in earthquake or flood prone areas. For seismic rated anchoring requirements contact a local engineering firm, in your area.
2. In areas where a threat of flooding or high winds exists, or in basements with a history of flooding, use of the tie-down kits is recommended.

## **Securing the Tank Package**

### **Strapping or Tie Down Kits are Required with Tank Mounted Hose Reel Applications**

1. Tie down kits are used as an aid to keep the tanks from shifting, tipping over or floating off the base.
2. The kit includes two tie downs, one for each side of the tank. Each tie down consists of long and short support rods with hooks on each end, turnbuckle and pre-drilled angle bracket.
3. Place long support rods onto the top rim of the tank. Hook the turnbuckle onto the long and short support rods. Hook the angle bracket onto the short support rod. Adjust the turnbuckle until the angle bracket touches the concrete and mark the fastening holes.
4. Anchor angle brackets to cement with field supplied fasteners. Loosen turnbuckle until short support rod can be hooked onto angle bracket. Tighten turnbuckle on each side evenly in an alternating pattern. Kits should be tight without deforming tank rim or sides of tank. **Do not overtighten.**
5. Be sure tank remains level during and after tightening the tie down kits.



6. Tie down kits may not be effective if the tank is less than half full and a flooding event occurs. In areas with a risk of flooding, please contact Roth Industries Technical Department to determine best method for securing tank.
7. Use one kit for 165 gallon tanks, use two kits for 275 & 400 gallon tanks.
8. Additional kits maybe used to increase stability or where conditions or code require it.

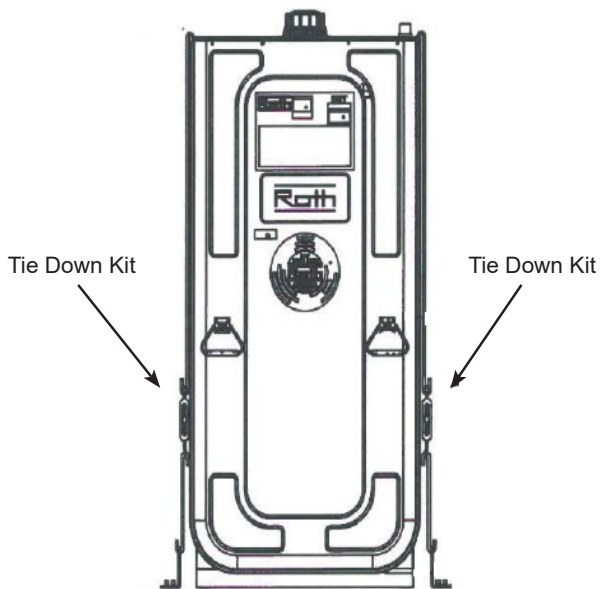

## Caution:

Tank restraints must not affect the containment properties of the tank. Penetrating fasteners are only allowed on the tank flange above the tank top.

## Piping Connections

1. All connections to the Roth/Balcrank tank package use a flat rubber #3 gasket to seal against the tank opening and to ensure the connection is odor free. The various fittings are secured to the tank with a large black plastic cap nut. Once installed, 18 ft-lb of torque applied to the cap nut seals the connection; hand tightening is the acceptable equivalent of this. The connections to the tank are designed to seal against atmospheric pressure only and not the higher fluid or pumping pressures. It can not be considered an oil tight connection. In the event the tank is overfilled, the connection may allow oil to seep onto the top of the tank.
2. Do not use pipe sealants or PTFE tape on any threaded plastic connections, as these products can cause the plastic to degrade. These sealants can be used on metal to metal connections.



## Normal and Emergency Venting

All atmospheric storage vessels require venting to prevent:

- Tank pressure accumulation while filling with liquid
- Tank vacuum accumulation while emptying tank

### Normal Venting

Normal vents function to allow the tank interior pressure to remain at or very near atmospheric during filling and emptying operations. Codes and ordinances may allow simple open vents for meeting this requirement. This requirement can be met with a 2" pipe nipple and a screened vent cap or vented fill cap which is included in the package.



Example of an "open" normal vent



832778 - Tank Vent Cap 2" NPT

In some locations, normally closed or pressure-vacuum vents may be required. This type of vent includes two valve assemblies, one designed to relieve accumulated pressure, another to relieve accumulated vacuum. When the tank is not being filled or emptied, both valves are closed retaining any vapor associated with the stored liquid. This type of vent also allows the tank to "breathe" with changes in ambient temperature resulting in small internal pressure changes.



Example of a normally closed pressure vacuum vent, image courtesy of Morrison Bros. Co.

Normal vents should be sized with consideration for maximum fill and emptying rates. In most cases, using vent sized to mount directly on the 2" NPT adapter will meet these requirements.

## Emergency Venting

Emergency venting allows the expanding interior atmosphere of the tank to escape in the event that the tank is exposed to external fire. Emergency vents are designed to open at a pressure slightly above the opening pressure of normal vents and are an option on the Balcrank/Roth tank package.



Example of an emergency vent, image courtesy of Morrison Bros. Co.

The tank can be equipped with emergency vents for the primary tank. Sizing of emergency vents is a function of calculating the wetted surface area of the tank and associated vent flow capacity requirements per NFPA 30. Please contact Roth Technical Service Department for assistance in sizing emergency vent equipment.

## Interstitial Emergency Venting

Codes and ordinances may require emergency venting be applied to the interstitial volume (space between the inner tank and the outer tank) in tanks with double wall construction. The Roth DWT is constructed as a closed diked double wall tank with a non-sealed interstitial, not designed for or capable of retaining pressure. Therefore, there is no requirement or facility to install an emergency vent on the interstitial.

## Testing and Inspection

1. As mentioned in Section 1, the inner and outer tanks of the Roth/Balcrank tank package are pressure tested at the factory to UL specifications (4.35 psi inner and 0.25 - 0.3 psi outer). Further pressure testing is not necessary and can result in damage to the tanks if attempted.
2. If pressure testing of the piping is required by local codes, all affected piping should be disconnected from the tank and one end sealed prior to performing testing. Pressurization of the piping should be no more than 0.5 psi (3.5 kPa) using a leak detection solution on the fittings
3. A hydrostatic test consisting of a thorough inspection of all connections during the first filling should be conducted.
4. Leaks found during these tests are generally from misaligned piping and loose fittings, or, on rare occasions, from defective fittings. Once the problem has been identified and corrected, review all aspects of the installation.

## Section 5 - Hose Reel Base and Hose Reel Installation

The following images and descriptions are meant to provide a general reference for mounting fittings and required accessories to the Roth/Balcrank tank package and reel base. Specific installation sites may require the use of different accessories or accessories to be mounted in different positions on the top of the tank which in no way adversely affects the function of the tank.

### 2" Metal Adaptors

1. Remove dust plugs and discard.
2. When attaching fittings/equipment to the 2" metal adaptors, loosen large plastic cap nut to prevent cracking. When securing adaptors to tank with cap nuts. Hand tighten only. Do not exceed 18 ft. lbs. of torque.



### Pump/Reel Base Kit

Base and Installation Hardware Kit

1136-003 - 26" for 165 gal

1136-003 - 26" for 275 gal

1136-004 - 28" for 400 gal

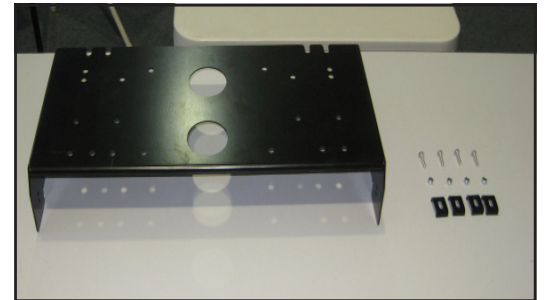

1. Place base on top of tank and center over tank openings.

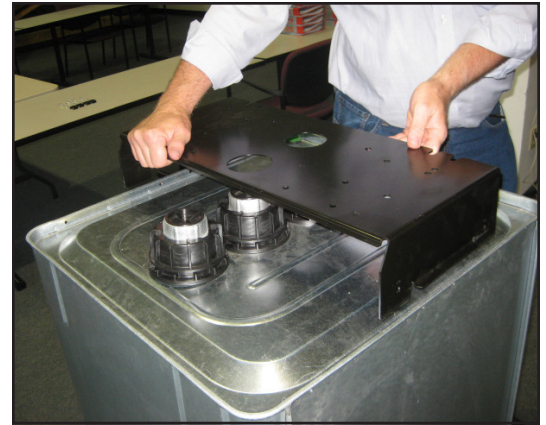

2. Insert bolt through pre-drilled hole in base leg.



3. Slide mounting clip over bolt with the curved edges facing the tank and base.



4. Place elastic stop nut on bolt with washer.





5. Secure clip with elastic stop nut and tighten.

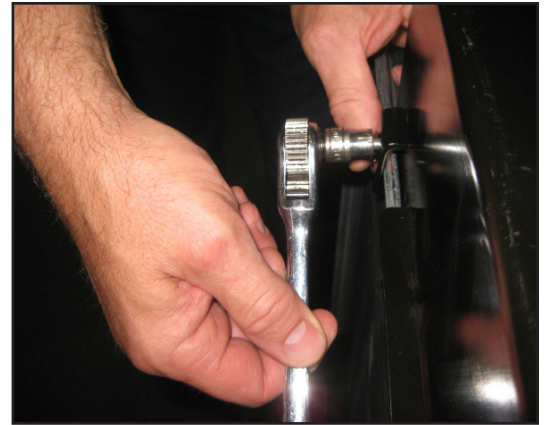

6. Be sure clip is seated firmly on both tank and base



7. Complete installation with remaining clips and fasteners.

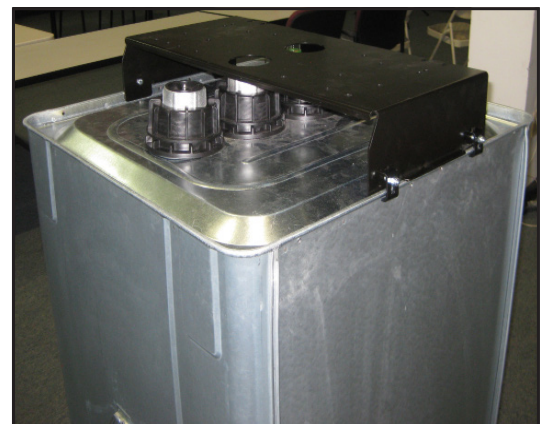

## Hose Reel

1. Base has two sets of pre-drilled holes for installation on right or left side.
2. Place Hose reel assembly on base and align with pre-drilled holes/slots.
3. Fasten assembly to base with 1/4" - 20 x 1 1/8" hex head bolt (4) and 1/4" - 20 elastic stop nut (4).

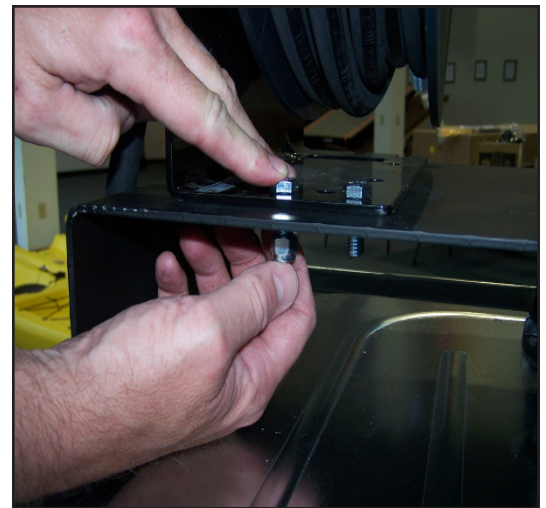
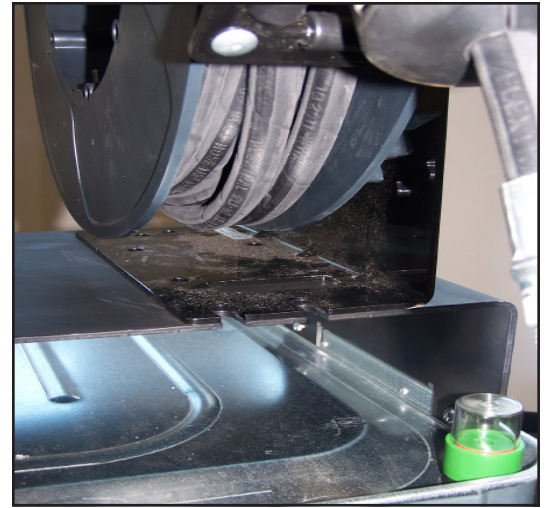

## Finished Assembly



## Section 6 - Balcrank/Roth Package Start-up & Commissioning

1. After placing tank package in desired location, ensure tank has been adequately filled with the proper fluid.
2. Connect airline to the pump with the provided airline quick disconnect.
3. Turn the air regulator up until the pump begins to cycle slowly. **DO NOT ALLOW THE PUMP TO CYCLE FAST DURING THE INITIAL START-UP.**
4. Point control handle into a container and slowly pull the trigger to allow any air in the oil system to evacuate. If the pump does not start slowly increase the air pressure to the pump until oil is flowing into the container and the pump is cycling smoothly.
5. Adjust the pump air pressure until the desired flow and pressure is achieved.

Note: If the pump does not prime in the first minute disconnect the airline and check the following:

1. Oil level is full
2. Air is properly connected to the pump.

If the pump will still not prime, contact the installing Balcrank Distributor or call Balcrank Technical Support Department at 800-747-5300 or 828-645-4261.



## Section 7 - Completed Installation Review and Warranty Documentation

1. Once the Roth/Balcrank tank package installation is complete, the installer shall review all the work done to verify it is in compliance with the instructions received in training and in this manual, as well as in compliance with applicable local code requirements.
2. Once the review is finished and all requirements are met, the two warranty certificates included with each tank must be completely filled in. One will be returned to Roth Industries at the address found on the certificate and the other will be given to the tank owner for his/her records.
3. Accurate completion of the certificates is extremely important, since this is the only proof that the installation met all warranty requirements.
4. The serial number and date of manufacture are printed on the silver label affixed to each certificate. The date of installation, the name of the tank owner, complete address of the installation, and the installer and/or installation company all need to be provided for the certificate to be valid.
5. Some state, provincial, or local authorities may also require that the installation checklist included in this manual be filled out and submitted as part of the warranty registration process. On both documents the installer's signature (either individual or company name) is verification that the installation conforms to all Roth/Balcrank tank package instructions and meets the requirements of all applicable codes.
6. Once the completed certificate and installation checklist (if required) are received by Roth, the information is then entered in the database for internal recording keeping and company use only. Roth does not send out notification that the warranty certificate has been received, but owners can call to verify that certificate has been received. This information is for warranty purposes only and will not be shared with any other company for reasons other than warranty maintenance.
7. The warranty is valid on the Roth/Balcrank tank package where it is originally installed and therefore remains in effect if ownership of the property is transferred. Any questions concerning the installation or the warranty can be addressed by calling Roth Industries at the telephone numbers listed on the front cover of this manual.
8. The first time the tank is filled, an observer, preferably the installer, should be present to determine that there are no problems that need to be addressed. It is much easier to remedy these problems before the tank is full.

## Section 8 - Yearly Maintenance and Troubleshooting

### Yearly maintenance

1. Inspect the site (floor or pad) for any shifting, cracking or unevenness. If any of these conditions exist the integrity of the tank and the installation may be compromised. Steps must be taken to provide a sturdy, level site for the tank.
2. Check that the tank is firmly and squarely set on the base.
3. Inspect all four sides of the tank, the base, and the top for any areas where the galvanized coating has broken down, allowing rust to start. If any spots like this are found, then lightly clean the area with steel wool or fine grit sandpaper, wipe clean, and then coat with any zinc bearing paint intended for galvanized metal.
4. Inspect all the seams in the tank, particularly the seam between the tank body and the top. If there has been excessive pressurization of the tank during filling, the rivets that hold the top in place can be seen pulling into or through the material behind them or in a lifting of the top's rim to expose the tank body's edge. If either condition is noted, contact Roth Industries to arrange an inspection of the tank.
5. Check the plastic cap nuts for tightness. They have been found to gradually loosen with the natural expansion and contraction of the tank during filling and emptying, as well as the expansion and contraction of the plastic nuts themselves from the temperature changes. If they are loose turn them until they are hand tight. This will be sufficient to seal the gasket with the appropriate pressure.
6. As pipe joints can loosen over time, inspect all pipe joints for evidence of leakage by fuel oil. If such evidence is found, then contact an oil service technician or installer to come and retighten the joints.
7. Inspect fill and vent piping for plumbness and that the piping slopes back to tank. Check to see the support brackets are secure and are keeping the weight of the pipes off the tank.
8. Check the top of the tank for any stains that may have occurred from oil seeping onto the top of the tank. If there is oil present on top of the tank, then this must be cleaned up or it will gradually seep into the interstitial space between the two tanks. If the stains are old with no odor, cleanup is optional.
9. Oil stains or oil on top of the tank is usually a sign that the tank was overfilled at some point. The oil company should be notified about this leakage, an optional vent alarm is available.

**By following these procedures, the Roth/Balcrank tank package will provide decades of reliable and trouble free oil storage. If in doubt, always call the Roth/Balcrank certified installer or use the numbers in this manual to reach Roth Industries or Balcrank Corp.**

## Troubleshooting

1. The red band is showing in the leak detector.
  - a. Remove the leak detector from the tank by pulling up out of the sealing rubber bushing and observe the amount of fluid (oil or water) visible on the end of the detector tube.
  - b. If the amount of fluid on the tube is less than a few inches it is nearly always an indication that fluid has seeped into the interstitial from the top of the tank from overfilling the tank.
  - c. If the amount of fluid on the tube is close to or equal to the amount of oil in the inner tank then it is an indication of a possible leak in the inner tank and the installation needs a closer inspection. Call Roth Industries Inc. to arrange such an inspection.
  - d. Fluid can be removed from the interstitial (space between the two tanks) with a hand pump or with a long rod that has an absorbent material attached to it if the amount is small. The cleanup can be finished by using oil absorbent powder, which will also remove most of the oil smell.
2. Oil smell near the tank
  - a. If there is the presence of oil of the top of the tank it is an indication of:
    1. Leaky pipe joints. Contact an oil service technician or installer.
    2. Plastic cap nuts are loose. Hand tighten or mechanically tighten to 18 ft-lb of torque.
    3. Overfill during filling. The oil company should be notified about this leakage. If a vent alarm is installed, make sure it is working properly.
  - b. If no oil is visible on the top of the tank then the following must be checked:
    1. Plastic cap nuts may be loose. Hand tighten or mechanically tighten to 18ft-lb of torque.
    2. The fill and vent piping is not plumb causing unequal pressure on the o-ring resulting in an air gap on one side of the o-ring. Contact your oil service technician or installer.
    3. Compression fittings on the duplex bushing may be loose.
  - c. Check the leak detector and following instructions above if red band is showing.
3. Tank sides are bulging and creases have formed on the sides of the tank
  - a. The sides of the tank may expand up to two (2) inches per side when filled. This is a normal condition.
  - b. Tank sides bulging more than normal is an indication of one of the following:
    1. Too high of a pumping rate during filling. The pumping rate should be 40 - 85 gpm (150 LPM - 300 LPM) with a maximum line pressure of 85 psi.
    2. Restriction in the vent piping. This can be caused by debris in the vent piping and/or vent cap or a problem with the vent whistle. Contact your oil service technician if the vent whistle is causing the problem.
    3. The interstitial has water in it and the water has frozen at some point. Call Roth Industries

# Roth/Balcrank Tank Package Fill Chart

		165 gal			275 gal			400 gal		
Fuel Level		Fuel Content			Fuel Content			Fuel Content		
in.	mm	US gal	Liters	% Full	US gal	Liters	% Full	US gal	Liters	% Full
1	25.4									
2	50.8				5	20	2%	11	40	2%
3	76.2	5	19	3%	11	40	4%	17	61	
4	101.6	9	34	5%	16	60	6%	22	82	5%
5	127.0	10	38	6%	21	80	8%	28	106	
6	152.4	14	53	9%	26	100	10%	34	130	8%
7	177.8	16	61	10%	32	120	12%	40	154	
8	203.2	18	68	11%	37	140	13%	47	178	11%
9	228.6	22	83	14%	42	160	15%	54	203	
10	254.0	25	95	16%	48	180	17%	60	228	14%
11	279.4	27	102	17%	53	200	19%	67	254	
12	304.8	29	110	18%	58	220	21%	74	280	17%
13	330.2	34	129	21%	63	240	23%	81	307	
14	355.6	36	136	22%	69	260	25%	88	334	20%
15	381.0	38	144	23%	74	280	27%	95	360	
16	406.4	40	151	25%	79	300	29%	102	387	24%
17	431.8	45	170	27%	85	320	31%	109	413	
18	457.2	47	178	29%	90	340	33%	116	440	27%
19	482.6	49	185	30%	95	360	35%	123	465	
20	508.0	51	193	31%	100	380	37%	129	490	30%
21	533.4	56	212	34%	106	400	39%	136	515	
22	558.8	58	220	35%	111	420	40%	143	540	33%
23	584.2	60	227	37%	116	440	42%	150	565	
24	609.6	65	246	39%	122	460	44%	156	590	36%
25	635.0	67	254	41%	127	480	46%	163	615	
26	660.4	70	265	42%	132	500	48%	169	640	39%
27	685.8	72	273	44%	137	520	50%	176	665	
28	711.2	77	291	47%	143	540	52%	182	690	42%
29	736.6	79	299	48%	148	560	54%	189	715	
30	762.0	81	307	49%	153	580	56%	196	740	45%
31	787.4	84	318	51%	159	600	58%	203	765	
32	812.8	89	337	54%	164	620	60%	209	790	48%
33	838.2	91	344	55%	169	640	62%	216	815	
34	863.6	93	352	57%	174	660	64%	222	840	51%
35	889.0	98	371	59%	180	680	66%	229	865	
36	914.4	100	379	61%	185	700	67%	235	890	54%
37	939.8	102	386	62%	190	720	69%	242	915	
38	965.2	104	394	63%	196	740	71%	248	940	57%
39	990.6	109	413	66%	200	760	73%	255	965	
40	1016.0	112	424	68%	206	780	75%	262	990	60%
41	1041.4	114	431	69%	211	800	77%	269	1015	
42	1066.8	116	439	70%	217	820	79%	275	1040	63%
43	1092.2	120	454	73%	222	840	81%	282	1065	
44	1117.6	123	466	75%	227	860	83%	288	1090	67%
45	1143.0	125	473	76%	232	880	85%	295	1117	
46	1168.4	127	481	77%	238	900	87%	302	1143	70%
47	1193.8	132	500	80%	243	920	89%	309	1170	
48	1219.2	134	507	82%	248	940	92%	316	1196	73%
49	1244.6	137	519	83%	254	960	95%	323	1223	
50	1270.0	141	534	86%				330	1250	76%
51	1295.4	144	545	87%				337	1278	
52	1320.8	146	553	89%				345	1305	80%
53	1346.2	148	560	90%				352	1333	
54	1371.6	153	579	93%				359	1360	83%
55	1397.0	155	587	94%				367	1390	
56	1422.4	157	594	95%				375	1420	87%
57	1447.8							383	1450	
58	1473.2							391	1480	90%
59	1498.6							399	1510	
60	1524.0							407	1540	94%
61	1549.4							412	1560	95%





## Fluid Dispensing Systems

### Customer Support

800-747-5300 or 828-645-4261

(Mon. - Fri., 8 am - 5 p.m. ET)

- Order entry
- Product availability and information
- Pricing
- Shipping dates and delivery information
- Return Merchandise Authorization

### Technical Support

800-747-5300 or 828-645-4261

(Mon. - Fri., 8 am - 5 p.m. ET)

- Repair advice
- Product application recommendations
- Warranty claims and returns
- Service bulletins

### Place an Order

**Phone:** 800-747-5300 or 828-645-4261

**Fax:** 800-763-0840 or 828-658-0840

- Fax orders day or night
- Order confirmed next business day by fax or e-mail

**E-mail:** [orders@balcrank.com](mailto:orders@balcrank.com)

**Online:** [www.shopbalcrank.com](http://www.shopbalcrank.com)

- Place orders on-line 24/7
- Pricing is live and specific to your account
- Track shipped orders

### Service Bulletins

[http://www.balcrank.com/Service/service\\_bulletins.com](http://www.balcrank.com/Service/service_bulletins.com)

## Warranty Statement

visit [www.balcrank.com](http://www.balcrank.com)

Roth Industries

USA Contact Info:

Syracuse, New York 13211

Toll Free: 888-266-7684

Fax: 866-462-2914

Email: [info@roth-usa.com](mailto:info@roth-usa.com)

Balcrank Corporation

Weaverville, NC 28787

Toll Free: 800-747-5300

Fax: 800-763-0840

Email: [info@balcrank.com](mailto:info@balcrank.com)