

# CARBON LITE

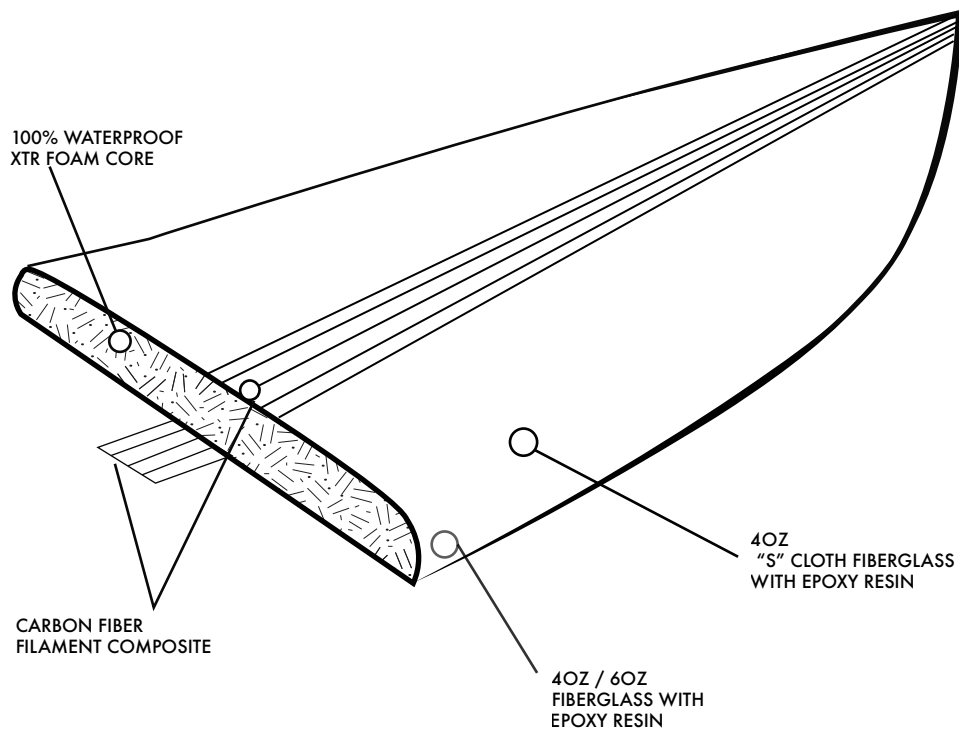

---

Flex Value 4-6

Center flex (comes standard with carbon tail patches)

Using a lite-weight carbon fiber placed directly on our XTR foam core from nose to tail on top and bottom provides liveliness, spring, and pop while still maintaining a traditional stiffness and rigidity of a center stringer-style flex. The carbon fiber's high strength-to-weight ratio allows for a thinner and lighter stringer, which can reduce the board's overall weight and increase its maneuverability and performance.

CL #1 150lbs or less

CL#2 150-175lbs

CL#3 175-200lbs +