

# ESCEND

## BLADES *ALPHA*

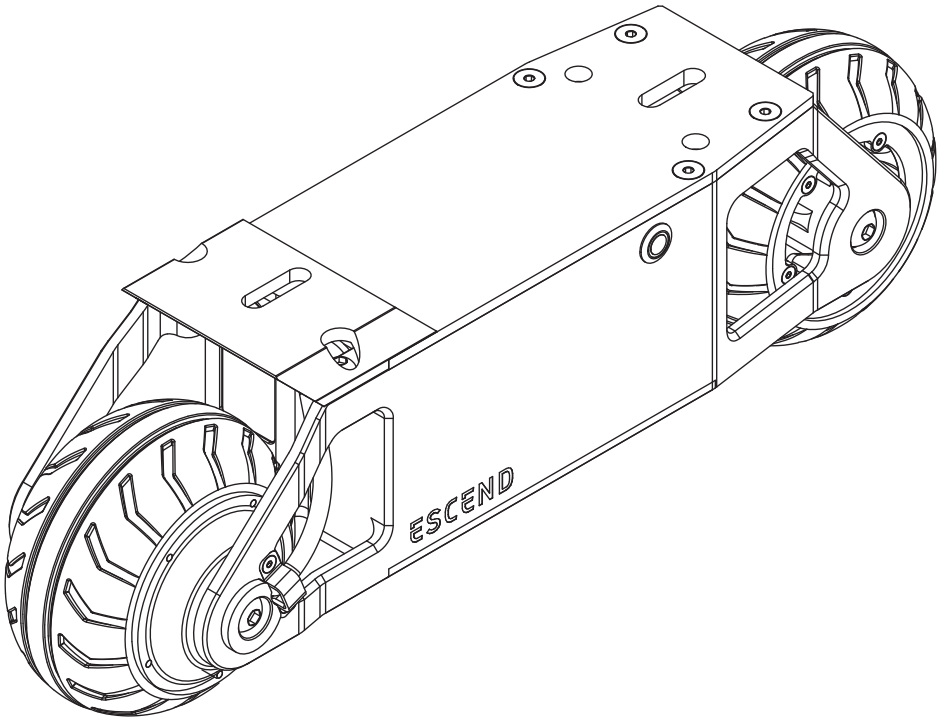

**Original Instructions**

Please read this manual before using the  
electric skates

---

[www.escendblades.com](http://www.escendblades.com)



# SAFETY WARNINGS



This Manual contains important safety information and warnings. Please read them carefully, ensure that you are safe and get used to the skates slowly.

Whenever you ride any micro-mobility product you risk death or serious injury from loss of control, collisions and falls. To ride safely, you must read this instruction manual and start in beginner mode. Just like any other sport, there are inherent risks involved.

## WARNING:

- ALWAYS wear a helmet and protection gear when riding.
- AVOID any wet, slippery and uneven surfaces.
- AVOID steep hills, traffic, large cracks or any obstacles that can cause a loss of traction.
- AVOID night riding and areas with poor visibility and limited space.
- Do not ride on any hills above 20 degrees incline.
- Do not ride at speeds which you cannot safely control.
- Do frequent maintenance checks to ensure the parts are not loose
- Do frequent maintenance checks on the vent label to ensure that it is not damaged or peirced. Replace the label if it is the case
- Do not charge the skates when they are powered ON. Ensure that they are always switched OFF during any maintenance or charging.
- In case of smoke coming from the skates or battery fire, remove the skate boots from your feet as quickly as possible and try to avoid inhaling any fumes



## WARNING - AVOID WATER:

The skates & remote are not completely waterproof. While the skates can go through small puddles they should not be completely submerged in water. Water damage is not covered under the warranty.



## WARNING - PINCH POINTS:

Keep fingers, hair and body parts away from the rotating wheels and small gaps in the skates.



## WARNING - RISK OF ELECTRIC SHOCK:

Do not open/tamper with the electronics which is located underneath the battery. Only use ESCEND approved batteries. Tampering or using other batteries will invalidate the warranty.

# DISCLAIMER

E-SK8 Ltd is the manufacturer of ESCEND Blades and the owner of the trademark name “ESCEND”. E-SK8 Ltd is the legal entity referred to in the disclaimer below.

1. E-SK8 Ltd is not responsible for any injuries that occur from using this product. Do not touch the motor or any parts of the skates while moving.
2. Do not tamper with the skates, open the electronics compartment, or make any non-approved modifications. This will immediately void the warranty and may cause the product to become illegal in your country.
3. E-SK8 Ltd is not responsible for the driving laws in your country, please read and understand any restrictions that may be applicable for this product in your country and abide by them. No refunds will be accepted based on inoperability of the product in a certain region.
4. Do not ride close to other riders and keep away from vehicles and pedestrians. We are not responsible for accidents resulting in collisions with other people or vehicles.
5. This product is not meant to be used by anyone under the age of 14 or anyone that does not have the ability to use the product safely, either physically or mentally.
6. Improper use of the skates might lead to failure and damage to the equipment. We strongly advise to read this manual carefully before using the skates and strictly follow the specified operating instructions. E-SK8 Ltd will bear no liability rising from improper use of this product.
7. E-SK8 Ltd will bear no liability arising from unauthorized modification of the product. E-SK8 Ltd has the right to change the product design, appearance, performance, outer package and operating requirements without prior notice.

# CONTENTS

	SAFETY WARNING	2
	DISCLAIMER	3
1.	INTRODUCTION	5
1.1	FEATURES	5
2.	GETTING TO KNOW THE SKATES	6
2.1	PACKAGING LIST	6
2.2	SKATE GLOSSARY	6
2.3	REMOTE GLOSSARY	9
2.4	REMOTE OLED DISPLAY	10
3.	USER INSTRUCTIONS	11
3.1	CHARGING - SKATE	11
3.2	CHARGING - REMOTE	11
3.3	POWER ON/OFF	12
3.4	CONNECTING & BINDING	13
3.5	OPERATING ESCEND BLADES	14
3.6	STORAGE AND MAINTAINANCE	15
3.7	BATTERY SAFETY	16
4.	GETTING STARTED	17
4.1	RIDING OUTSIDE PRIVATE PROPERTY	17
4.2	TIPS FOR RIDING ESCEND BLADES	18
5.	MAINTENANCE INSTRUCTIONS	19
5.1	FRONT WHEEL MAINTENANCE	19
5.2	MOTOR TYRE REPLACEMENT	20
5.3	BATTERY REPLACEMENT	21
5.4	VENT LABEL REPLACEMENT	23
5.5	FRAME POSITION	24
5.6	BOOT INSTLLATION	24
5.7	DOOP BOOTS INSTLLATION	25
5.7	UFS ADAPTER INSTLLATION	26
6.	TECHINCAL PARAMETERS	27
7.	WARRANTY	29
7.1	STANDARD WARRANTY COVER	29
7.2	RETURNS PROCEDURE	30
8.	FCC REQUIREMENTS	31
9.	PRODUCT ID & MANUFACTURER INFORMATION	32

# 1. INTRODUCTION

---

Thank you for purchasing ESCEND Blades - Alpha.

It is a portable and eco-friendly personal mobility transport, which is incredibly fun to use. Its' compact dimensions and high manoeuvrability make it perfect for commute and recreational journeys.

The frames are compatible with most skate boots so you can ride ESCEND Blades in the comfort of your own boots!

It allows you to travel up to 15km with a top speed of 25 km/h. It is equipped with advanced braking systems and engineered with reliability in mind.

Enjoy your ride and stay safe!

## 1.1 FEATURES



Top Speed



Full Charge Range

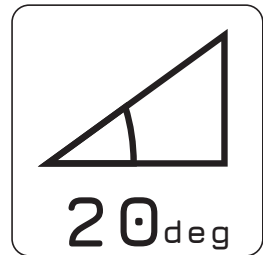

Max Gradient



20-80% Charge Time



105mm Tyres

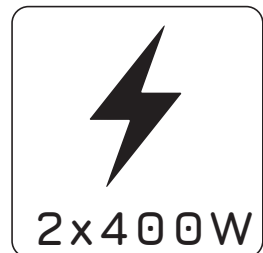

Motor Power

## 2. GETTING TO KNOW THE SKATES

---

### 2.1 PACKAGING CONTENTS

#### PARTS:

- LEFT SKATE (x1)
- RIGHT SKATE (x1)
- REMOTE (x1)
- SKATE CHARGER (x1)
- REMOTE CHARGER (x1)
- BOOTS (OPTIONAL)
- EXTRAS (OPTIONAL)

#### TOOLS:

- 5mm Hex Key (x1)
- 4mm Hex Key (x1)
- 3mm Hex Key (x1)
- 2.5mm Hex Key (x1)
- 2mm Hex Key (x1)

#### SPARE PARTS

- Vent Label (x2)

### 2.2 SKATES GLOSSARY

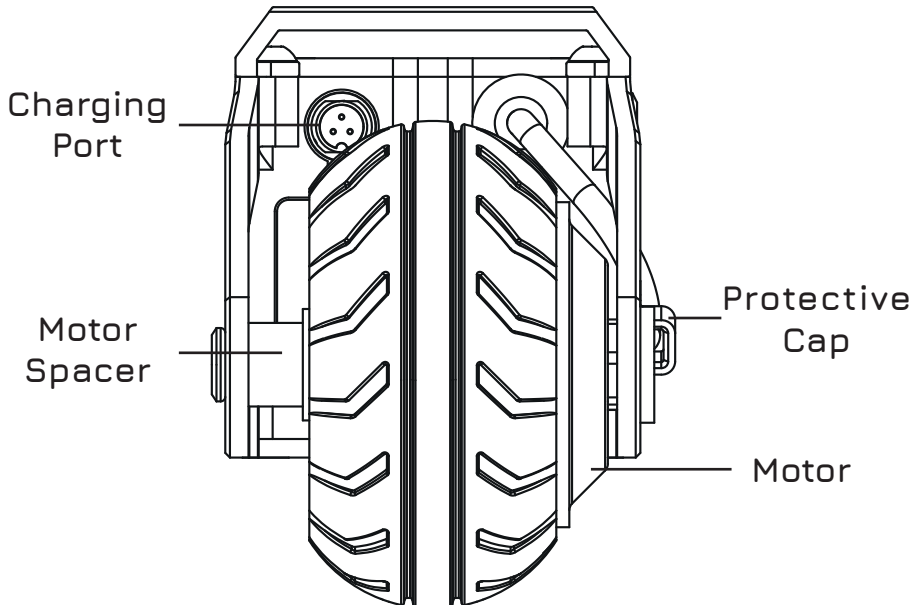

Motor Mount

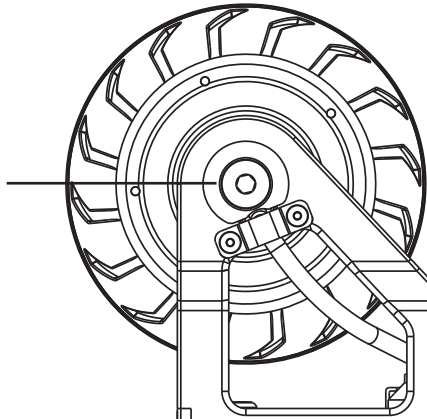

Heel Support



Bottom Panel

ESSEND



Power Switch



Front Wheel

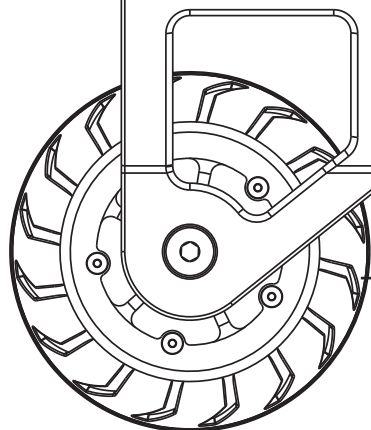

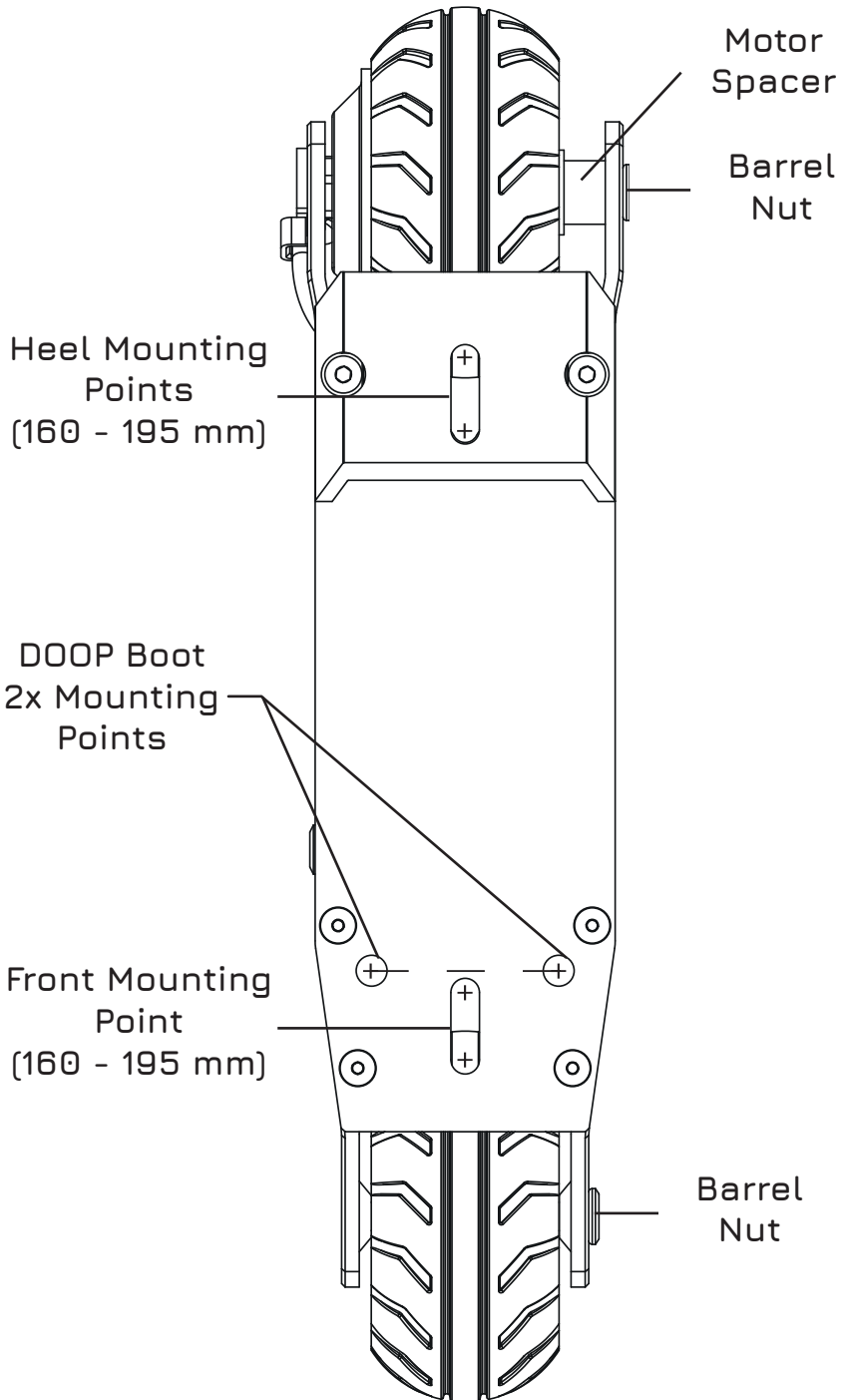



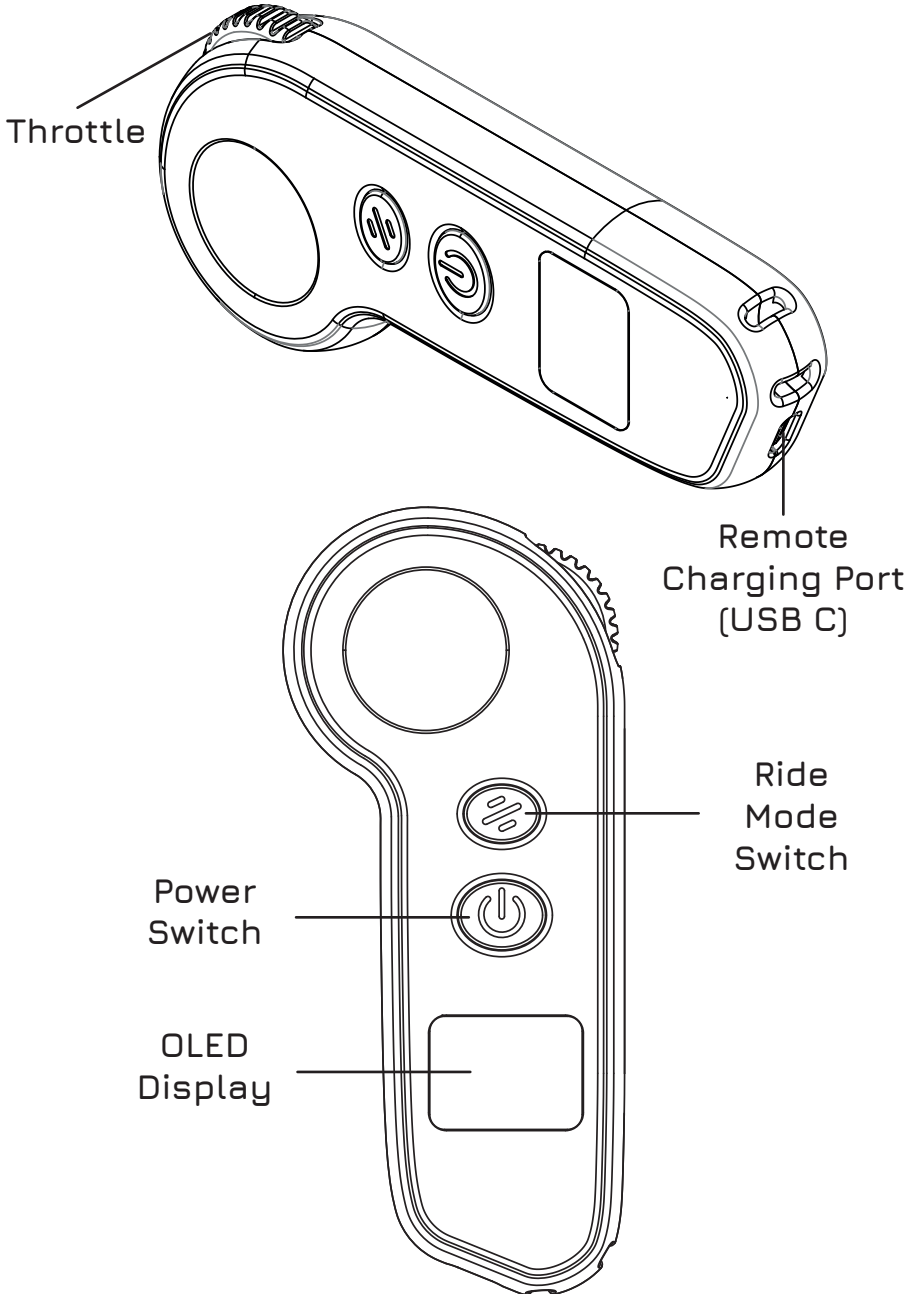

## 2.3 REMOTE GLOSSARY

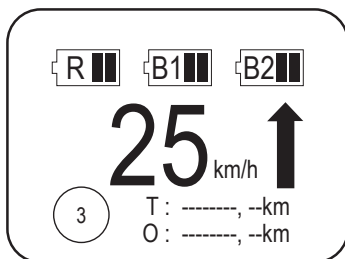
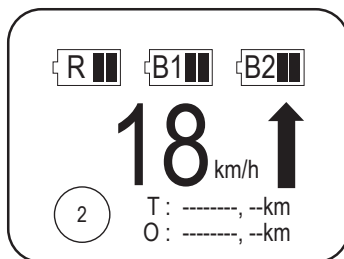
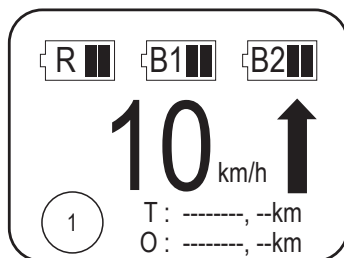
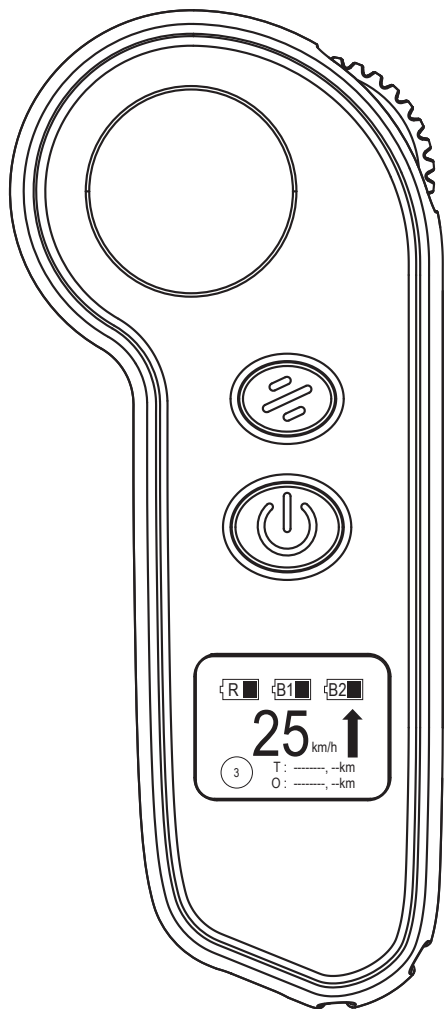

## 2.4 REMOTE OLED DISPLAY



 Remaining capacity of the remote battery

 Remaining capacity of skate 1 battery

 Remaining capacity of skate 2 battery

① ECO

② TURBO

③ COMMUTE

↑ FORWARD

↓ REVERSE

T: TRIP DISTANCE

O: ODOMETER

### 3. USER INSTRUCTIONS

---

#### 3.1 CHARGING - SKATE

1. Remove the rubber cover on charging port
2. Ensure the orientation of charger groove is the same as on charging port and plug in the charger

**Notes:**

- The indicator on charger turns green when skates are fully charged or when the charger is disconnected from skates
- The indicator on charger turns red during charge
- Charging time is approximately 2 hours 15 mins

**Charging Port**

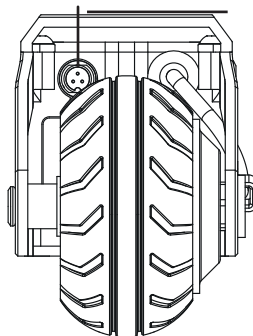

**WARNING: Never leave the skates unattended when charging. The skates must be powered off when charging**



#### 3.2 CHARGING - REMOTE

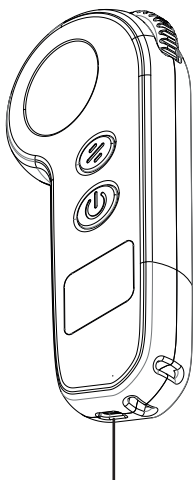

**Charging Port**



**30 min**

1. Plug in the charger into the remote charging port (USB - C)

2. Once it starts charging, a notification will be shown on OLED display

**Notes:**

- Remote charge time is approx. 30mins
- Remote will show fully charged when complete

### 3.3 POWER ON/OFF

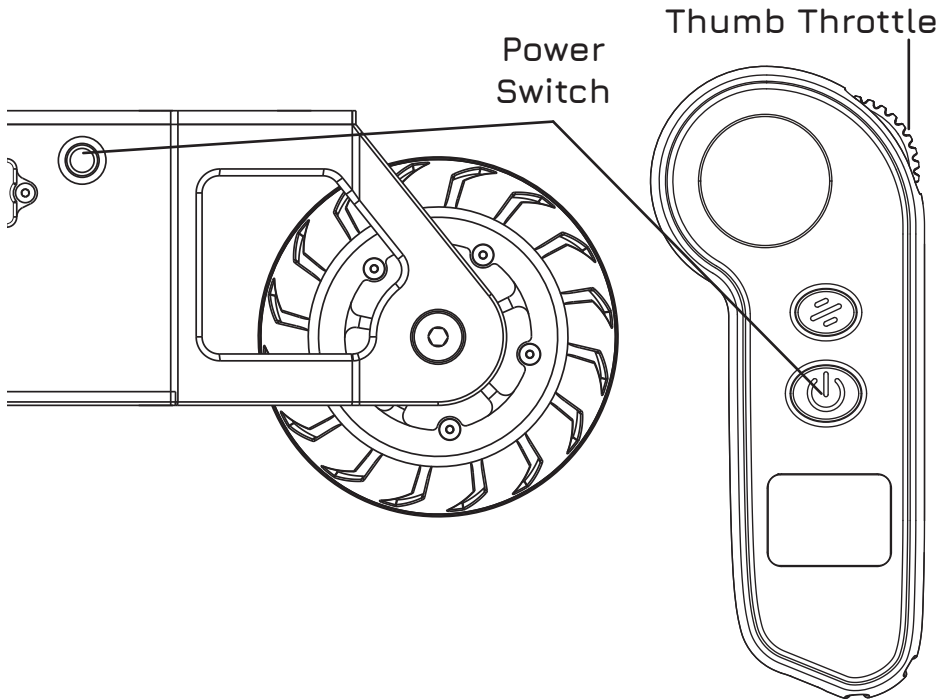

1. Power on the skates and remote by holding the Power Switch for 2 seconds, until the light/indicator turns on

2. Repeat the same steps for powering off the devices

Note: You can power on the devices in any sequence

3. Once all of the devices are powered on, the remote should be connected to both skates and show its "DEFAULT SCREEN" state (speed, battery charges, driving direction and etc.)

If the display screen shows "DISCONNECT" error, proceed to "3.4 CONNECTING & BINDING" instruction

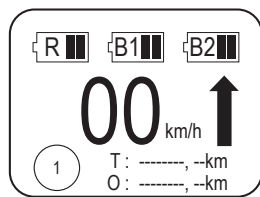

DEFAULT SCREEN

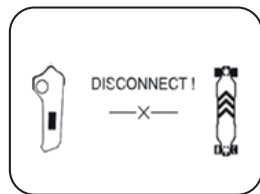

DISCONNECT SCREEN

## 3.4 CONNECTING & BINDING

Connecting & Binding operation should be used for pairing the remote to skates, changing the remote units, changing the level of regenerative braking and adjusting drivetrain system for a different wheel size

- Prior to doing this procedure, ensure that both skates and remote are switched off

- Use the “Thumb Throttle” to switch between units by pushing it forward or backwards

- Use the “Power Switch” button to confirm the selected unit

**STEP 1:** Press and hold the **Power Button** on Remote until it asks you to select “2WD” or “4WD”. Select and confirm “4WD” mode

**STEP 2:** The remote will ask for connection to “ESC1”. Press and hold the **Power Button** of the right-side skate until it starts rapidly flashing

**STEP 3:** The remote will ask for connection to “ESC2”. Press and hold the **Power Button** of the left-side skate until it start rapidly flashing

**STEP 4:** Select and confirm the desired speed/ distance unit “MPH” or “KM/H”

**STEP 5:** Toggle and select “Hub Motor” on the next screen

**STEP 6:** Toggle and select “105 mm” for the wheel diameter. If you are using different wheel size, select the diameter accordingly

**STEP 7:** Toggle and select for the Brake Level to be “100%”

**STEP 8:** When display goes to normal operational display the pairing is successful

**Note:** If after pairing procedure the motors go in reverse when the direction on remote is indicating forward, repeat the pairing procedure, ensuring you pair a different skate first during STEP 2

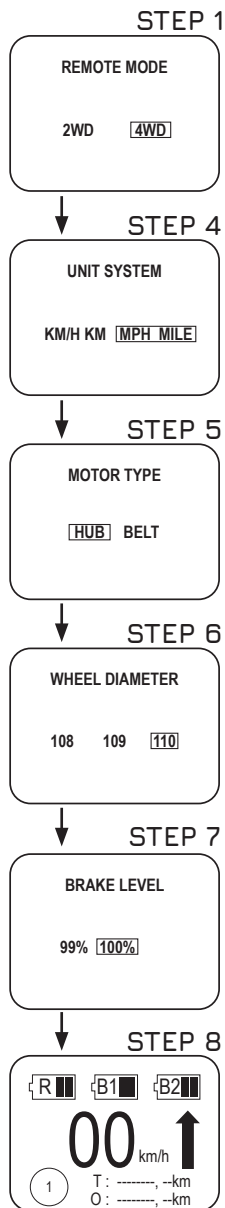

### 3.5 OPERATING ESCEND BLADES

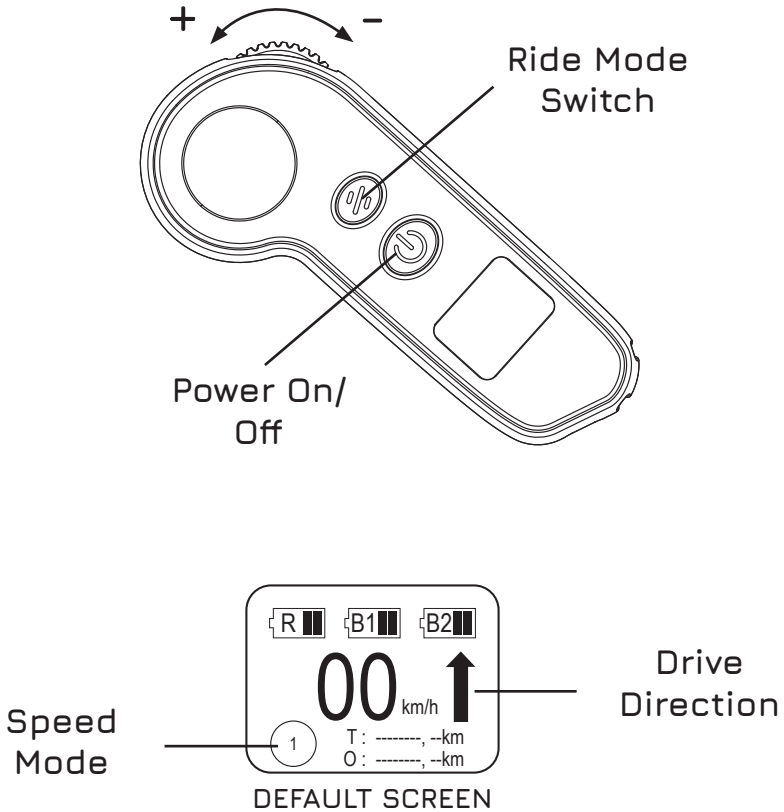

#### Accelerating & Braking:

- Push the thumb throttle forward to accelerate
- Push the thumb throttle backwards to brake

#### Changing the ride mode:

- Single click the "Ride Mode Switch" button to switch between speeds modes 1, 2, 3
- Double click the "Ride Mode Switch" button to change between "Forward" and "Reverse" driving modes

## 3.6 STORAGE & MAINTENANCE

- Check all screws are tight before riding and do frequent in-depth maintenance checks
- Clean front wheel bearings regularly following industry standard guidelines
- Make sure the skates and remote are turned off when not in use
- Recharge the battery in a well-ventilated area and do not leave unattended
- If the skates are to be stored for longer periods of time with no use then charge them for 30 minutes every one month to keep them operational
- DO NOT charge in a wet or damp area
- DO NOT charge when the skates are powered ON
- Only use the ESCEND charger supplied
- DO NOT use the battery to power any other equipment
- DO NOT take apart the electronics and tamper with cabling
- Check all wires for damage before every use

## 3.7 BATTERY SAFETY

Lithium-ion batteries are dangerous if not used correctly and cared for. They can explode and cause a fire. It is recommended that you read the following instructions very carefully:

- Each time you ride the skates check the screws on the bottom panels are tight and check the protective seals are not showing
- In case of any serious impact to the skates (drops, collisions), thoroughly inspect the skates' functionality (spinning wheels, frame integrity, electronics functionality)
- Never expose the battery to temperatures above 40 Degrees Celsius
- Only use the official ESCEND charger
- Never leave the skates unattended when charging
- Never run the skates while charging
- If you do not plan on using the skates for more than 2 months, then try to leave the battery around 50% charge (SOC)
- Before riding again fully charge the skates to rebalance the cells
- Do not let a fully charged battery stay in the charger for long periods of time
- If throwing away a battery find a dedicated battery disposal facility in your area





## 4. GETTING STARTED

---

Read “Safety warnings” and “Disclaimer” on pages 2-3 prior to getting started.

- ALWAYS WEAR A HELMET
- Wearing other protective gear is highly recommended: Knee pads, Elbow pads, Wrist pads, reflective clothes

Follow these tips to ensure a safe riding experience:

- Find an open, flat area with clean pavement for your first ride
- Move the throttle in small increments when accelerating and braking
- Keep legs wide apart when starting and one foot in front of the other
- Keep a low centre of gravity
- Lean forward when accelerating / Lean backwards when braking
- For more learning tips, scan the QR code below to see the video tutorials on our Youtube channel



Chanel Name: ESCEND

### 4.1 RIDING OUTSIDE PRIVATE PROPERTY

- Abide by the laws and regulations of your country or state
- Respect other drivers and pedestrians on the road and pavements
- Avoid riding in busy traffic and crowded areas
- Cross the roads at designated crossings and signalled intersections
- Identify and keep a safe distance away from hazards and obstacles
- DO NOT ride the skates on any private property without permission
- DO NOT ride on roads without abiding by country-specific laws

## 4.2 TIPS FOR RIDING ESCEND BLADES

### SPEED BUMPS

Take care when going over speed bumps, do not go over them at high speeds and keep your balance. Even though the skates can handle a level of abuse they are not designed for extreme jumps or tricks. Damage resulting from hard riding will not be covered under the warranty.

### UNEVEN SURFACES

Be careful when riding on uneven and bumpy surfaces. This could throw you off-balance and cause a dangerous situation, especially for inexperienced riders. Avoid sharp manoeuvres and keep to a speed within your comfort level.

### SIDEWALK / ROAD JUNCTION

Take care when stepping up or down any sidewalks, take them at a slow speed and lift one leg at a time onto the new level surface. If the surface is less than 3cm you can ride straight up it but take them at 45-degree angles and maintain your speed, while keeping your balance.

### ZEBRA CROSSING AND ROAD MARKINGS

Please take care when going over slippery surfaces (e.g. painted road markings) when the road is wet. If you must go on them do not accelerate / brake fiercely, keep to a low speed and avoid sharp manoeuvres.

### PARKED CARS, PARKING LOTS AND PEDESTRIANS

Take extra caution and slow down when riding around cars and pedestrians. They may not see you or may not be paying attention to their surroundings. Slow down around emerging or parking cars and ride as if they cannot see you!

### WATERLOGGED ROADS

This could be a hazard to your skates and is recommended you do not ride on waterlogged roads. Do not immerse the skates in water and avoid big puddles. Water damage is not covered in the warranty.

# 5. MAINTENANCE INSTRUCTIONS

---

**WARNING:** Ensure that each skate and remote are powered off when during any maintenance procedure

## 5.1 FRONT WHEEL MAINTENANCE

1. Loosen the Front Wheel from a fixed position by unscrewing Axle Screw with 5mm Hex Key and pull it away from the frame
2. Bearings can be removed by using the plastic round feature on 4mm Hex tool handle
3. To remove the Tyre, use 2.5mm Hex key to unscrew x5 M4x8mm screws and pull the Tyre out from the Rim

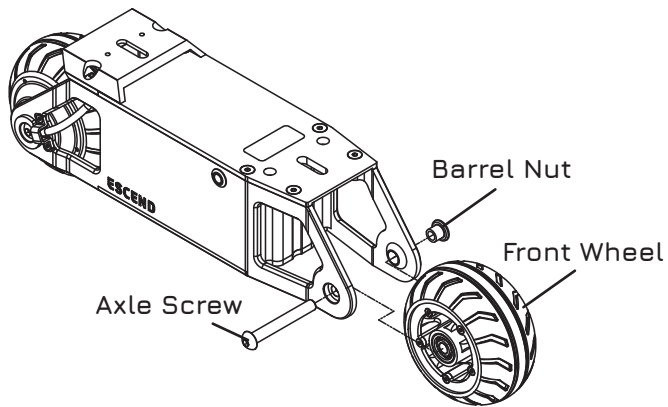

Bearing Replacement:

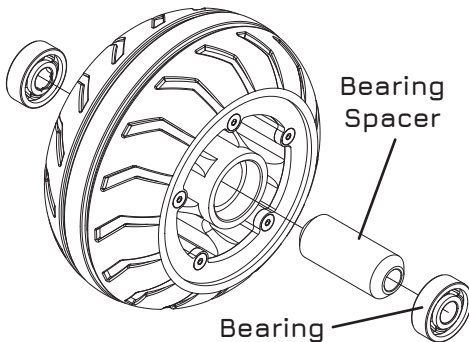

Tyre Replacement:

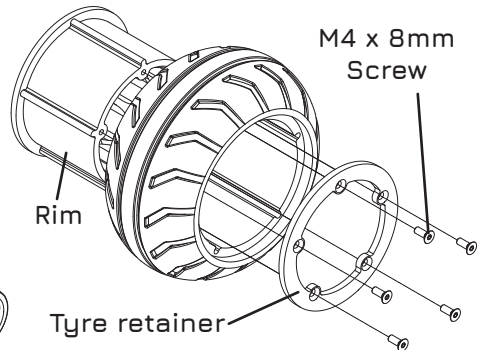



## 5.3 BATTERY REPLACEMENT

**WARNING:** When replacing the battery, ensure that it is done in a dry and safe environment. Remove any items of clothing or jewellery that can conduct electricity (metal) and short the terminals on XT60 connector.

Prior to battery removal and installation, battery pack should be visually inspected for any damage on the main body and wires. The damage can be in a form of stripped insulation on the wires or visible deformation to the main body.

Failure to follow the instructions may result in a risk of electric shock or fire!

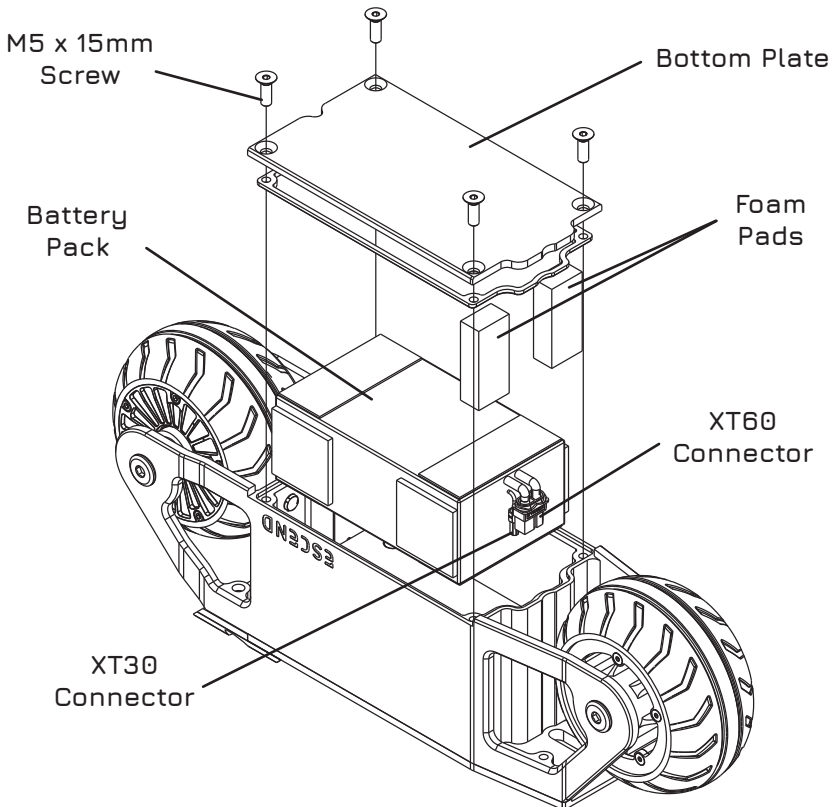

1. Remove the bottom panel by removing x4 M5 screws with 3mm Hex Key
  2. x2 Foam Pads should be removed from enclosure prior to removing battery pack
  3. Battery pack should be taken out of the frame prior to disconnect procedure. Once there is sufficient space to reach the connectors (XT60, XT30 connectors), they should be disconnected
  4. Install the new battery pack by connecting XT60, XT30 connectors to the wires protruding from the enclosure, tucking them away and slotting the battery pack into the frame enclosure.
- WARNING: When tucking away the battery wires, ensure the wires don't get trapped between the frame and top plate. This could damage the wires and lead to a risk of fire.**
5. Insert and position x2 Foam Pads back to where they were prior to removing them
  6. Prior to bottom plate installation, position the gasket on the bottom plate recess, ensuring the orientation is correct. Ensure the gasket chamfer is facing outwards
  7. Replace the bottom panel and ensure the gasket is firmly in place. Secure the panel using the four M5 screws.
  8. During the bottom plate installation, ensure that there are no visible gaps between the top plate and frame. This can occur if the gasket gets trapped.
- NOTE:** If there are any gaps large enough to fit your fingernail through, then the bottom panel should be re-assembled. The gasket should be re-aligned to make sure that it does not get trapped between the top plate and frame.

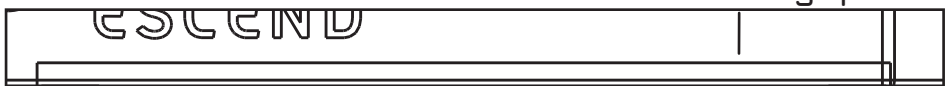
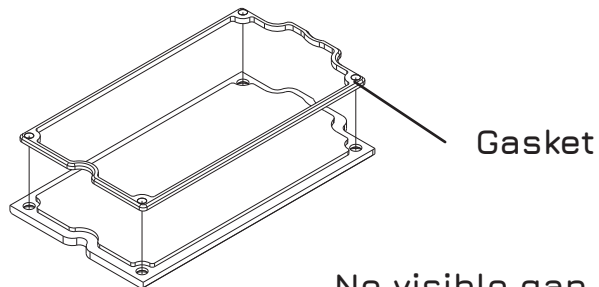

## 5.4 VENT LABEL REPLACEMENT

**NOTE:** Vent Label should be replaced if it gets pierced, damaged or it starts to peel off

1. Remove the old Vent Label
2. Clean the application area with IPA solution or alcohol wipes, ensuring that it is free from any sort of contamination. Make sure for IPA solution to dry out prior to applying the new label.
3. Position and stick the new label into recess and apply pressure to it for 30 seconds

**NOTE:** Applying pressure helps the label adhesive set

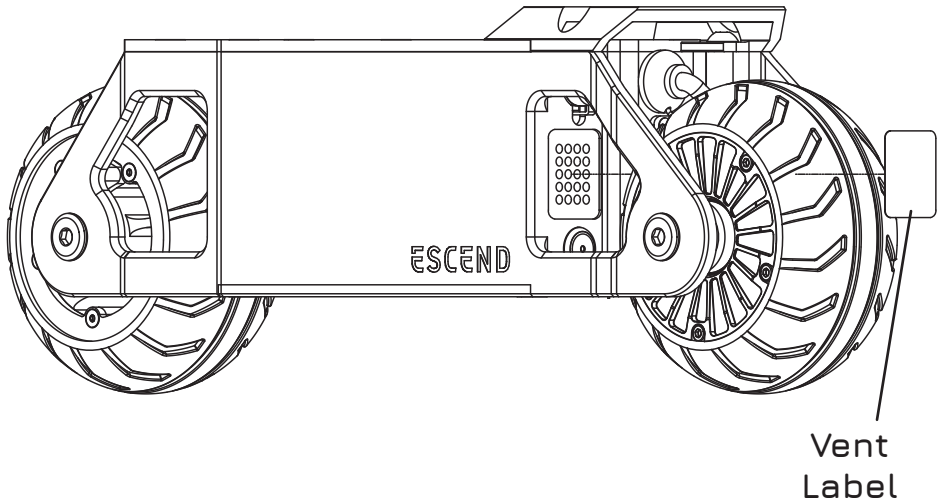

## 5.5 Frame Position

NOTE: When installing the boots, make sure the left and right boots are mounted to correct frames. This will minimise the level of scratches and wear on the frames caused by falls and other damage.

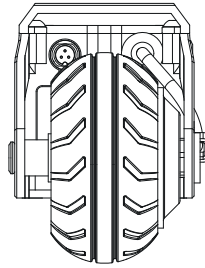

Left frame

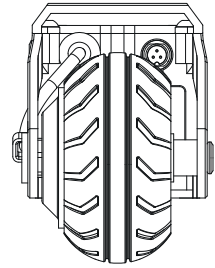

Right frame

## 5.6 Boot Installation

1. Turn the boot upside down and position the skate platform over it, aligning the boot mounting points with frame holes.

2. Secure the boot to the frame through the heel mounting point, while allowing the boot to move horizontally

3. Secure the boot front mounting point, while allowing the boot to move horizontally

NOTE: You can now adjust the boot position on the frame. We recommend moving it as far forward as possible, to allow for easier riding.

4. Select the boot position on the frame, tighten the screws and repeat the same steps for the other boot

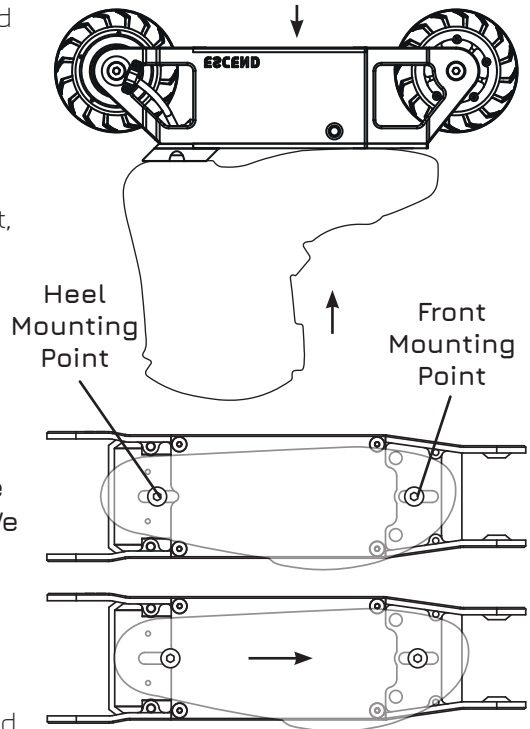

FRONT WHEEL AND MOTOR ARE NOT VISIBLE FOR DEMONSTRATION PURPOSES



# 5.7 DOOP Boots installation

1. Prior to mounting Doop boots to frames, adjust the boots to fit your foot size by changing the position of ankle support on the soleplate

**NOTE:** We recommend trying out the doop boot with your shoes to adjust it perfectly and making a note of the Ankle Support position on the soleplate

2. Turn the boot upside down and position the skate platform over it, aligning boot mounting points with frame holes

3. Secure the boot to the frame through the heel mounting point, using M6 Screw while allowing the boot to move horizontally along the frame.

4. Align the square nuts with x2 frame mounting points and secure them with M6 screws, while still allowing the boot to move along the frame.

**NOTE:** You can now adjust the boot position on the frame. We recommend moving it as far forward as possible, to allow for easier riding.

5. Select the boot position on the frame, tighten the screws and repeat the same steps for the other boot

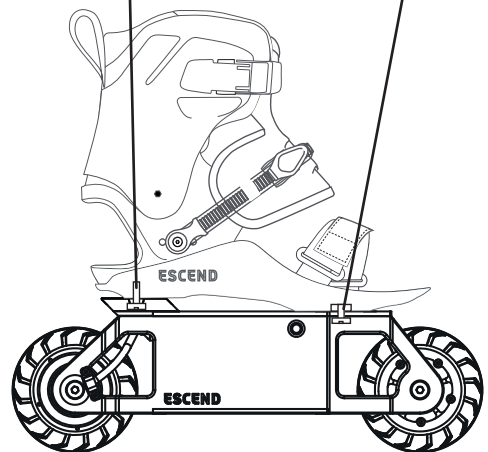
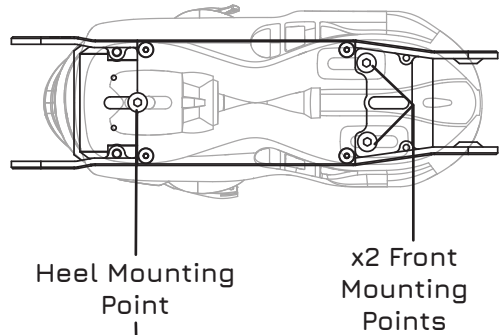
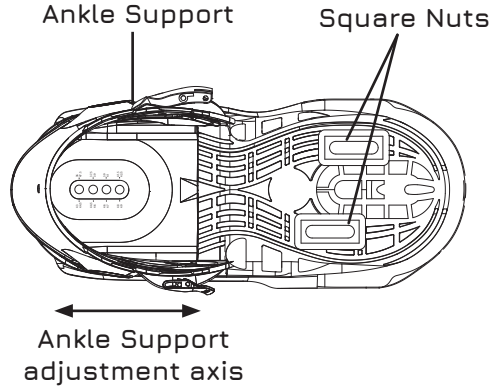

## 5.8 UFS Adapter installation

1. Prior to UFS adapter installation, heel support should be removed by undoing x2 M6x15mm (Button Head) screws
2. Prior to UFS adapter installation, x2 front M5x15 mm (Countersunk Head) screws on the Top Plate should be removed
3. Install UFS heel support by securing it against the frame with x2 M6x15mm (Button Head) screws
4. Install UFS front support by securing it against the top plate with x2 M5x15mm (Countersunk Head) screws
5. Repeat the same steps as in Section 5.6 - Boot Installation

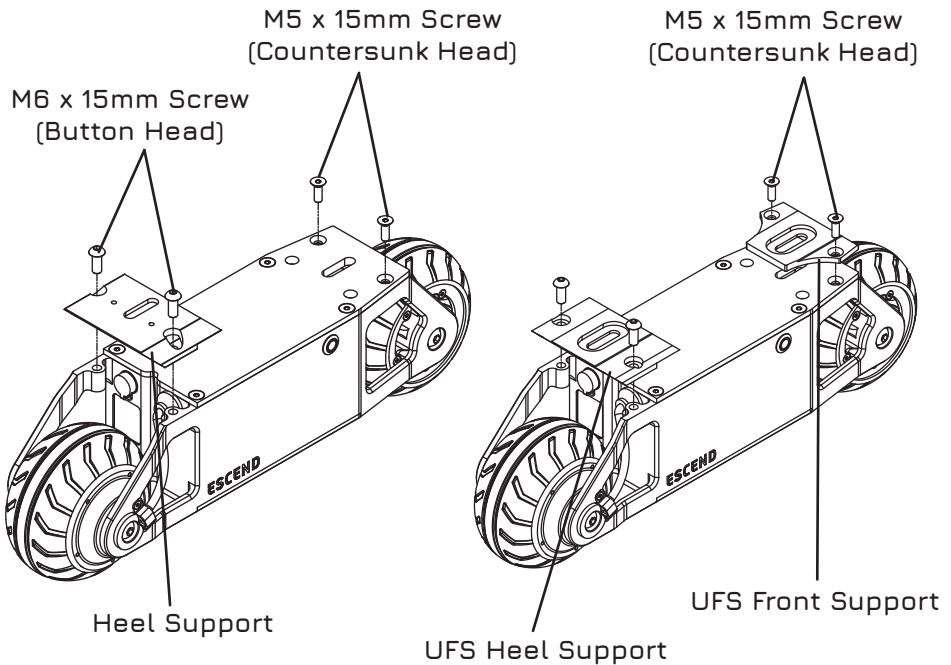

## 6. TECHNICAL PARAMETERS

SECTION	PARAMETERS	DETAILS
<b>Product Specification</b>	Dimensions	129.5 x 99.7 x 394.9mm (Per Skate Platform)
	Wheelbase	290 mm
	Total Weight	3.7 kg x 2
	Ground Clearance	32.5 mm
	Climbing Angle (Max)	20 Degrees Incline
	Frame Material & Thickness	Aluminium 6061
<b>Product Performance</b>	Min Load	40 kg
	Max Load	100 kg
	User Age	14+ Years
	Speed	ECO: 8-12 km/h
		COMMUTE: 18 - 22 km/h
		TURBO: 22-25 km/h
Range	12 - 16 km/h	
<b>Battery Parameters</b>	Battery Type	Lithium-ion (Cylindrical Cells 18650)
	Voltage	18V(Min) / 21.6V (Nom) / 25.2 (Max)
	Capacity	5600 mAh
	Size	120x69x47 mm
	Configuration	6S2P
	Protection Measures	BMS: Overvoltage, Undervoltage, Overcurrent, Short Circuit, Overheating

SECTION	PARAMETERS	DETAILS
<b>Motor Parameters</b>	Motor Type	Permanent magnet BLDC Hub Motor - 90 x 64.3 mm
	Rated Output	400W x 2
	Torque	5 Nm
	Max Instant Power	600W x 2
	Rated Voltage	25.2V Max
<b>Tyres &amp; Bearings</b>	Type	Silicone Rubber - Puncture Proof
	Specification	105 mm Dia - 70A Hardness
	Bearing	ABEC 9 - Wicked Chrom Steel
<b>Charger Parameters</b>	Input Voltage	110 - 230V AC
	Output Voltage	25.2 V
	Output Current	2.5 A
	Charging Time (20% to 100%)	2 Hours 15 Minutes
	Charging Time (20% to 80%)	1 Hour 15 Minutes
	Indicator	Red: Charging / Green Charged
<b>Remote Parameters</b>	Nominal Voltage	3.6V - Lithium Ion
	Capacity	300 mAh
	Charging Port	USB - C
	Charging Time	30 minutes
	Communication Method	2.4 GHz Radio
	Material	ABS Plastic

## 7. WARRANTY

---

### 7.1 STANDARD WARRANTY COVER

- The warranty covers all products sold by ESCEND through their official website or official channels.
- Please check the quality of the products upon arrival and contact us if anything is out of the ordinary. For items damaged upon arrival, you must contact us within 2 weeks of receiving the product. Any other defects that fall under warranty must be reported within 6 months.
- We offer a 6-month (180 days) Warranty on parts from the date of receiving the skates

**If a defect arises during the warranty period, ESCEND will either:**

- Send the new parts to replace the defective parts.
- Exchange the affected products with functionally equivalent products that are new or formed from new and/or previously used parts that are equivalent to new in performance and reliability.

**What is not considered a defect?**

- Minor Blemishes
- Damage resulting from abuse (drops)
- Accidents
- Neglect
- Severe water damage
- Installation failures (3rd party charging cable, wrong assembly, etc)
- Daily wear and tear
- Intentional modifications
- Items not sold by us or authorised resellers
- Items not manufactured by us
- Misuse, mishandling of item
- Theft or loss of the product

This warranty excludes damage resulting from abuse, accident, modifications or unauthorized workmanship repairs, neglect, abuse, water damage, or other causes that are not defects in materials

This warranty excludes normal depletion of consumable parts such as:

- Wheels / Tyres
- Bearings
- Fasteners
- Other types of wear

Our Standard Warranty only applies exclusively to products bought on the official ESCEND website and re-sellers. ESCEND products purchased elsewhere such as an unauthorised re-seller, or second hand are NOT covered by ESCEND's Standard Warranty.

## 7.2 RETURNS PROCEDURE

Any warranty claims must go through the official channels by filling out a returns form and waiting for confirmation from ESCEND team. Any products that are received with no "Returns" documentation will be destroyed.

To obtain warranty service, you MUST provide:

- Detailed reason for return
- 2 x Photos of the product and proposed problem
- Order number
- A contact name with a phone number
- Pack the items in the original packaging
- Confirm shipping address
- Confirmation of warranty return acceptance from ESCEND

This warranty excludes gifts unless the product is returned by the original purchaser.

## 8. FCC REQUIREMENTS

---

Changes or modifications are strictly prohibited and if not expressly approved by the party responsible for compliance could void the user's authority to operate the equipment.

This device complies with part 15 of the FCC Rules. Operation is subject to the following two conditions:

1. This device may not cause harmful interference
2. This device must accept any interference received, including interference that may cause undesired operation

NOTE: This equipment has been tested and found to comply with the limits for a Class B digital device, pursuant to part 15 of the FCC Rules. These limits are designed to provide reasonable protection against harmful interference in a residential installation. This equipment generates, uses and can radiate radio frequency energy and, if not installed and used in accordance with the instructions, may cause harmful interference to radio communications. However, there is no guarantee that interference will not occur in a particular installation. If this equipment does cause harmful interference to radio or television reception, which can be determined by turning the equipment off and on, the user is encouraged to try to correct the interference by one or more of the following measures:

- Reorient or relocate the receiving antenna.
- Increase the separation between the equipment and receiver.
- Connect the equipment into an outlet on a circuit different from that to which the receiver is connected.
- Consult the dealer or an experienced radio/TV technician for help.

# 9. PRODUCT ID & MANUFACTURER INFORMATION

---

**MANUFACTURED BY:** E-SK8 Ltd

**MANUFACTURER ADDRESS:** 20-22 WENLOCK ROAD, LONDON,  
N1 7GU, UNITED KINGDOM

**EU AUTHORISED REPRESENTATIVE:** Comply Express Unipessoal  
Limitada, StartUp Madeira, EV141, Campus da Penteada, 9020 105  
Funchal, Portugal

**MODEL NUMBER:** AV1

**FCC ID:** 2A7XJ - AV1

**IC ID:** 28809 - AV1

**SERIAL NUMBER:**

PLACE LABEL  
HERE

**WARNING:**

**READ THE INSTRUCTIONS MANUAL FOR SAFETY INSTRUCTIONS  
AND TO AVOID ANY RISK OF INJURY**

FOR MORE INFORMATION VISIT: [WWW.ESCENDBLADES.COM](http://WWW.ESCENDBLADES.COM)

