

AIR
helper

RETRUE
YOUR RELIABLE PARTNER

OWNER'S MANUAL

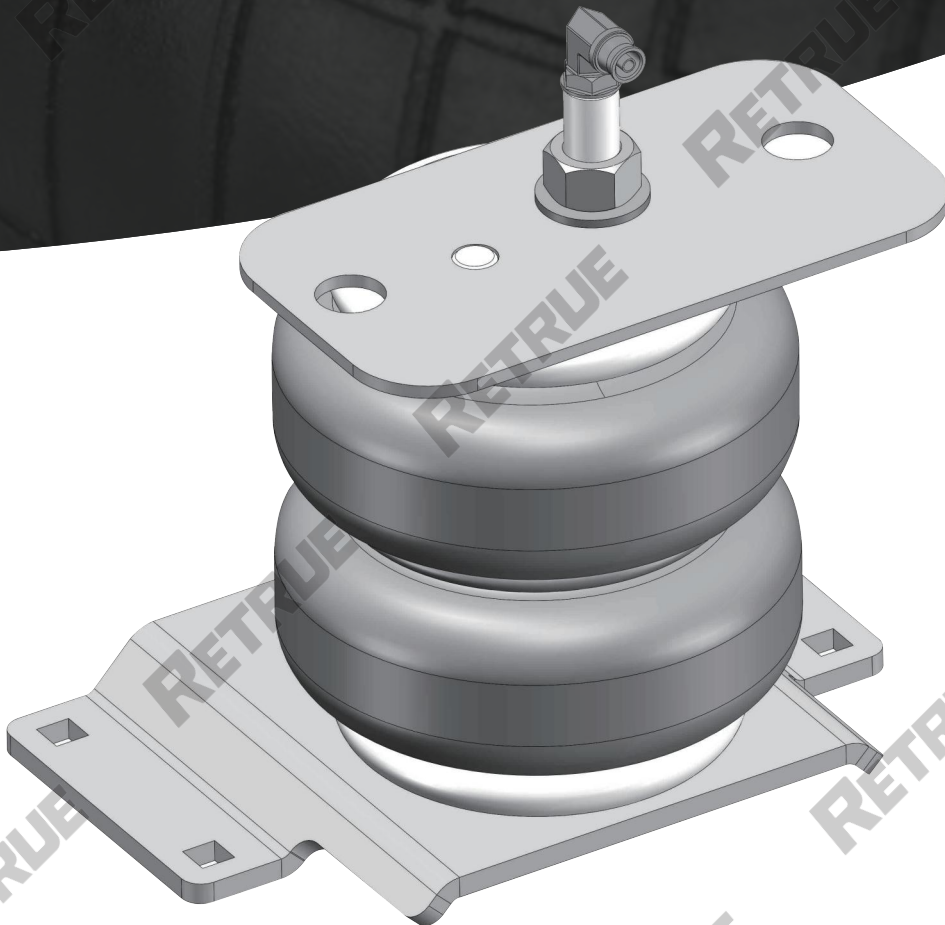

RAS2445-NS

PICKUP LIFTING KIT, FOR PICKUP TRUCK REAR ONLY

— AIR HELPER SPRING KIT —

SOFTAG



CATALOG

SAFETY INSTRUCTIONS

01 - 02



PARTS LIST

03 - 04



AIR HELPER SPRING KIT INSTALLATION

05 - 14



STEP 1: REMOVE THE EXISTING JOUNCE BUMPER	05
STEP 2: UNFASTEN THE FUEL PUMP CONTROL & PREPARE EXTENSION BRACKET.....	06
STEP 3: FASTEN THE AIR SPRING TO THE LOWER BRACKET	07
STEP 4: PREPARE THE UPPER BRACKET	08
STEP 5: INSTALL THE AIR SPRING ASSEMBLY.....	09
STEP 6: INSTALL THE LEAF STACK STRAP BRACKET	10
STEP 7: REINSTALL THE FUEL PUMP CONTROL.....	11
STEP 8: INSTALLATION OF INFLATION VALVES.....	12
STEP 9: CUT THE AIR LINE TUBE INTO TWO EQUAL LENGTHS	12
STEP 10: INSTALL AIR LINE TUBE INTO AIR FITTINGS AND INFLATION VALVE	13
STEP 11: ROUTE AND SECURE AIR LINE TUBES	13
STEP 12: FINISH THE INSTALLATION & CHECKING	14

WARNING TIPS

15 - 16

TROUBLE SHOOTING GUIDE

17 - 18



WARRANTY GUIDELINES

19



DISCLAIMER

20



CONTACT INFORMATION

21

SAFETY INSTRUCTIONS

Thank you for your purchase. Please take some time to read the following before starting your installation to avoid injury or unnecessary damage to your vehicle or the kit. If the truck has been lifted and the stock jounce bumper spaces are not on the vehicle, the installation is prohibited. Please note that this kit is for pickup trucks only and does not increase the maximum load of your vehicle.

Please note that the air pressure of the product should be between 5PSI and 100PSI after successful installation.



5 PSI

MINIMUM PRESSURE



100 PSI

MAXIMUM PRESSURE
(LOADED)

■ SAFE INSTALLATION

Please pay attention to safety and use appropriate protective tools during the installation. Please note that hydraulic jacks could fail during installation, and when this happens it can cause serious personal injury and possibly death if you are relying on it to support the vehicle. If you use a hydraulic jack, secure the jack in place and jam any tires that are still touching the ground. Please wear goggles, it is important. Eliminate the possibility of any electrical problems by disconnecting the negative battery cable.

■ KIT CLEARANCE

There must be a minimum of 1/2" clearance around all installed components when the Air Spring (A) is inflated and under load. It needs some space to flex and expand during the operation, therefore clearance is necessary.

■ VEHICLE GVWR

Never exceed the maximum load specified by the vehicle manufacturer. The GVWR could be found on the data plate on the driver's side door or in the vehicle's manual.

■ HOW TO INFLATE THE AIR SPRING

Be aware the Air Springs (A) maximum volume is way less than the tire's. Please check the air pressure frequently when you are inflating the Air Springs (A).

■ PRESSURE TO LOAD

Every Air Spring (A) can support approximately 50lbs of load for each PSI of inflation pressure.

■ THE RECOMMEND AIR PRESSURE

For the best ride, we recommend using only enough air pressure in the Air Spring (A) to level your car be in a straight line from front to rear when viewed. Of course, much depends on your driving preferences, the weight of the load, the location of the load, and the current air suspension settings. Differences in all of these factors can lead to a different driving experience.

■ SAFETY REGULATIONS & GUIDELINES

Follow all relevant local, state, and federal safety regulations and guidelines while using the Air Helper Spring Kit.

Air Springs (A) enhance vehicle handling and comfort. Proper installation is crucial to maximize their benefits. Review instructions to identify components and their usage. Start by comparing kit parts with the PARTS LIST.

The core of the Air Helper Spring Kit is the Air Springs (A). Ensure ample clearance for them to flex and expand without contact.

Prioritize safety during installation. Instructions and illustrations pertain to the driver's side; mirror the process for the passenger's side.

Your kit provides separate Inflation Valves (R) and Air Line Tube (F) for each Air Spring (A), enabling side-to-side and front-to-back leveling. For a single valve system, your dealer can provide the necessary "T" fitting.

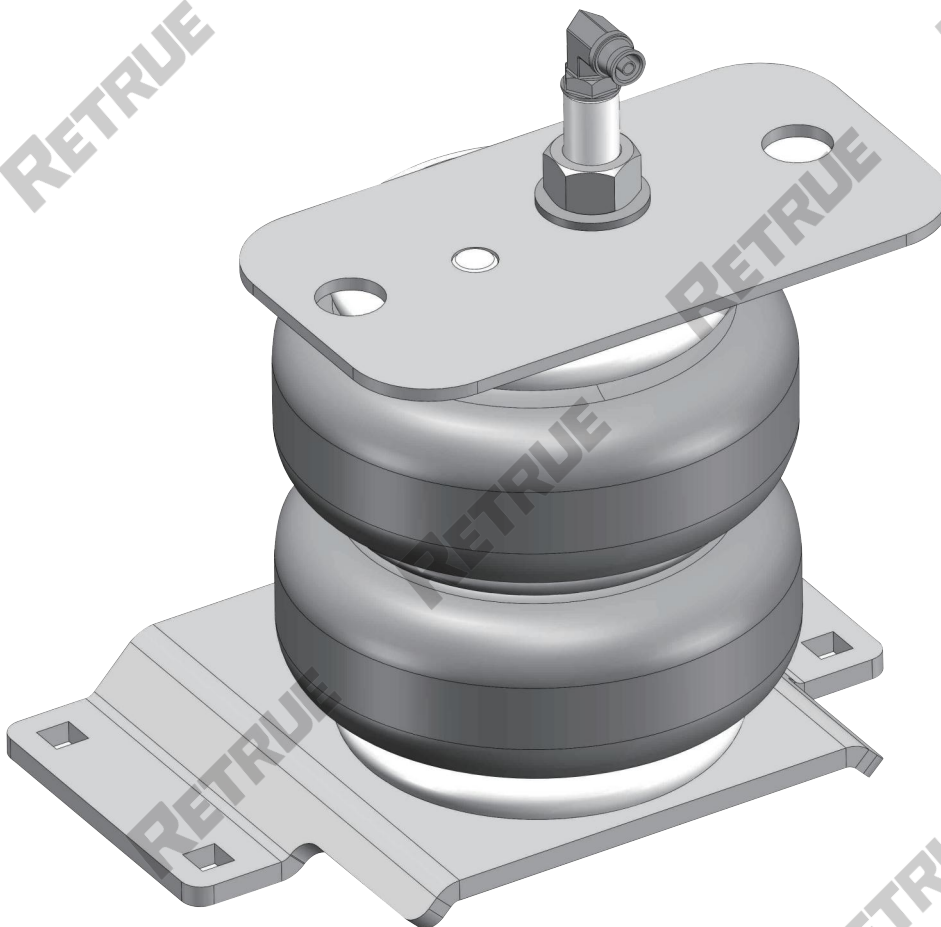

WARNING!

Do not inflate this assembly when it is unrestricted. The assembly must be restricted by the suspension or other adequate structure. Do not inflate beyond 100 PSI. Improper use or over inflation may cause property damage or severe personal injury.

PARTS LIST

Double check the parts below with the kit you received. Make sure you have all the components, and organize them for installation.

MAIN KIT CONTENTS

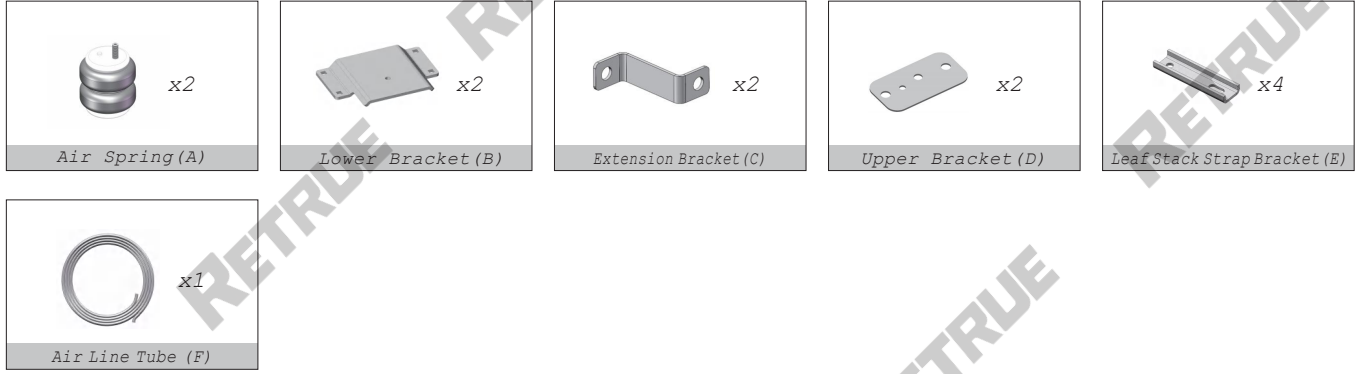

INFLATION VALVE BRACKET KIT

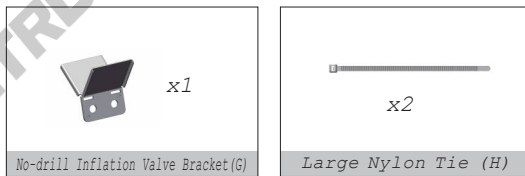

HARDWARE PACK

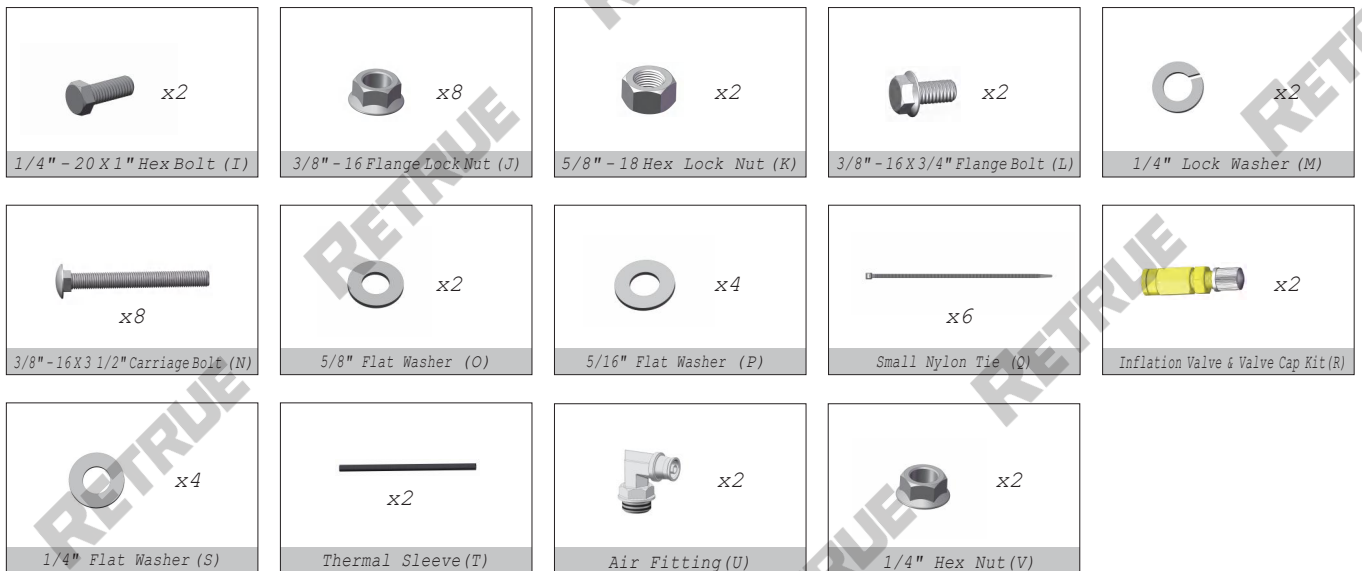

RETRUE May Provide Additional Accessories In Case Of Some Parts Are Lost Or Damaged.

INSTALLATION DIAGRAMS (DRIVER'S SIDE)

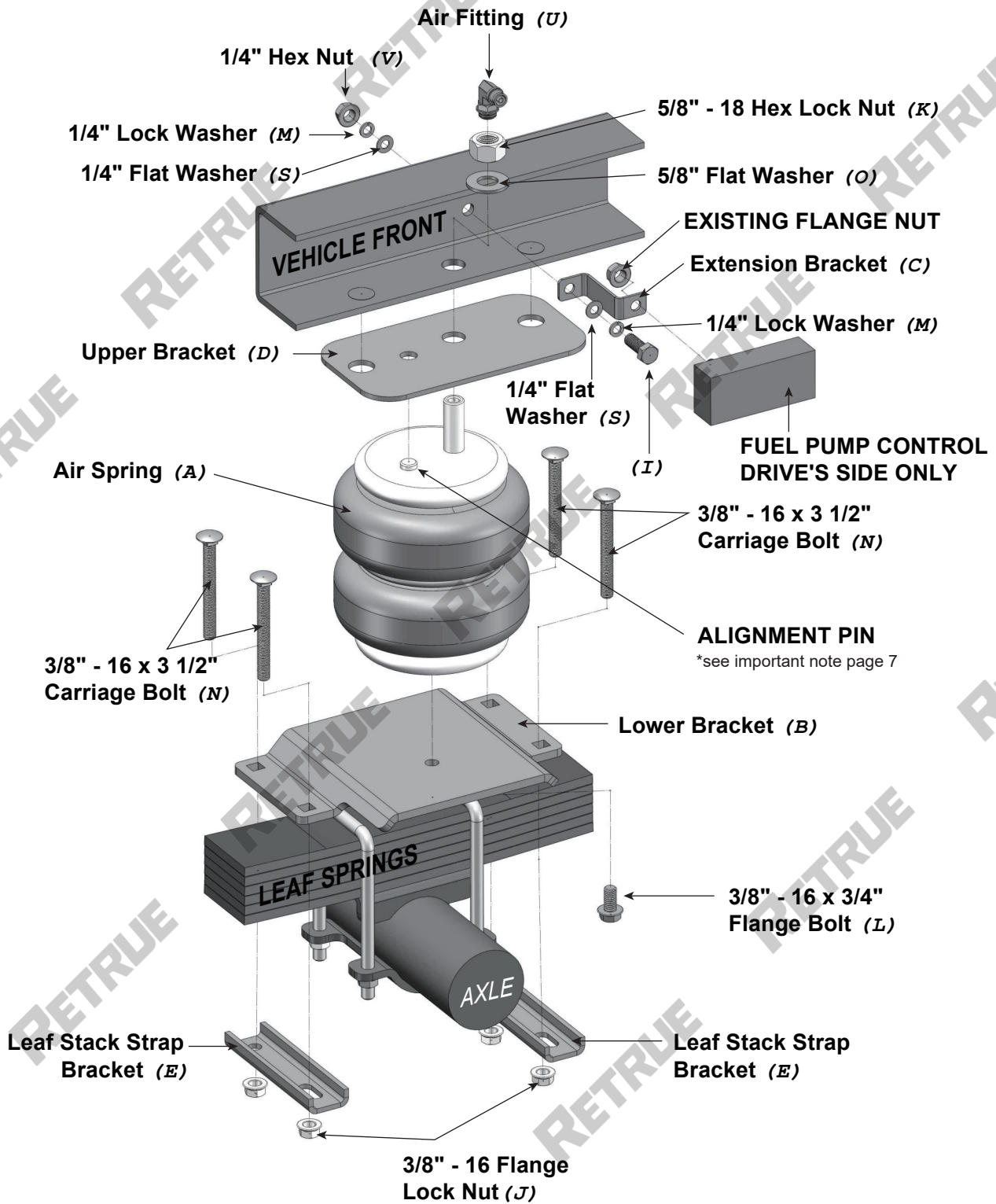

AIR HELPER SPRING KIT INSTALLATION

1 REMOVE THE EXISTING JOUNCE BUMPER



PLEASE INSTALL FROM THE DRIVER'S SIDE WHEN THE VEHICLE IS FACING FORWARD.

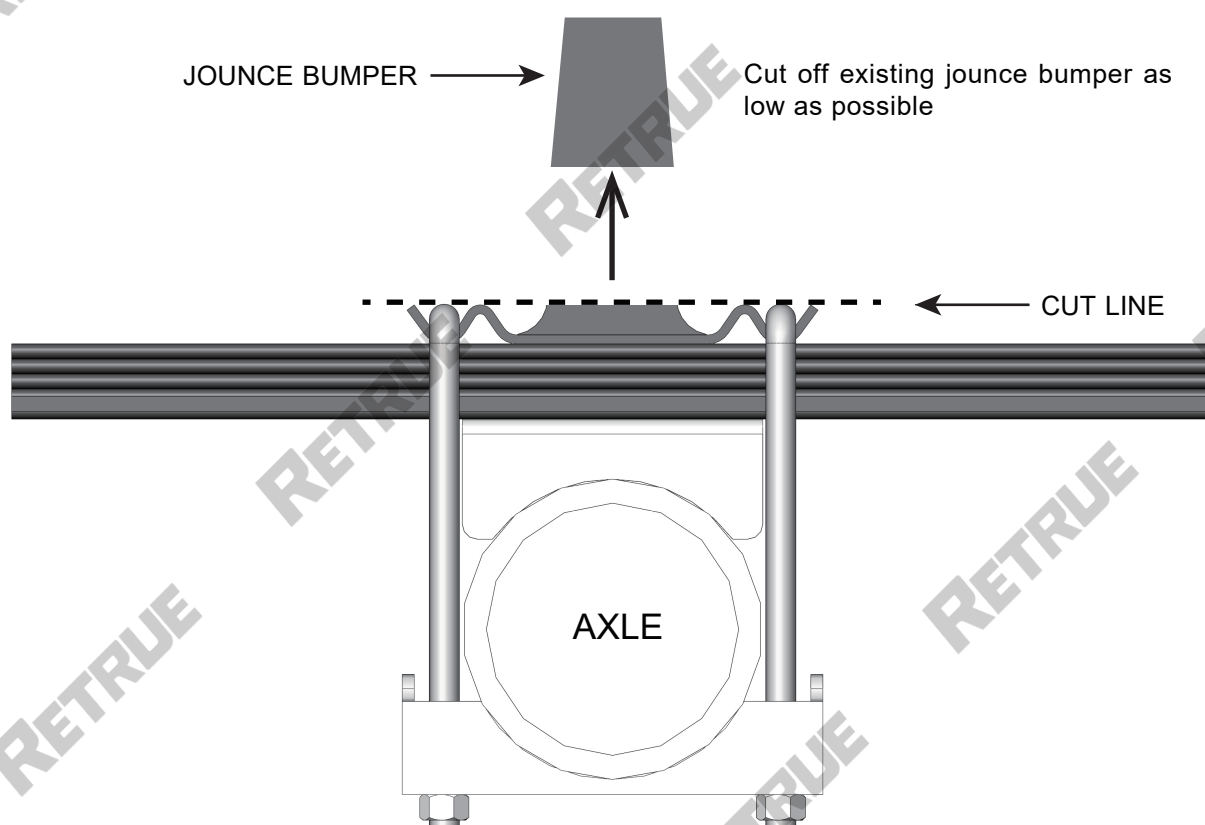

2

UNFASTEN THE FUEL PUMP CONTROL & PREPARE EXTENSION BRACKET

DRIVER'S SIDE ONLY

Unfasten fuel pump control from frame.

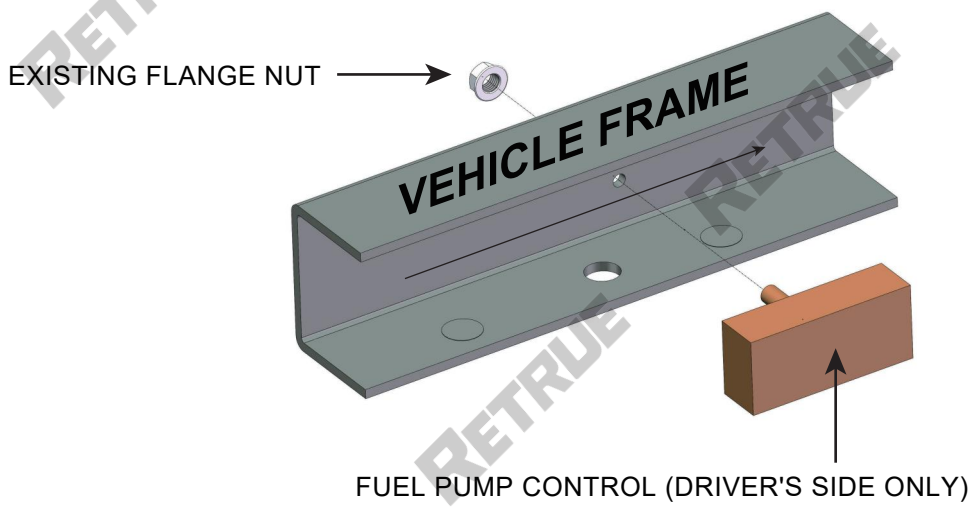
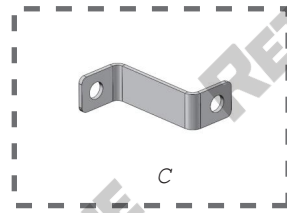

Please use the EXISTING FLANGE NUT to fasten the FUEL PUMP CONTROL to the Extension Bracket (c). Don't fasten the Extension Bracket (c) to the vehicle frame yet.

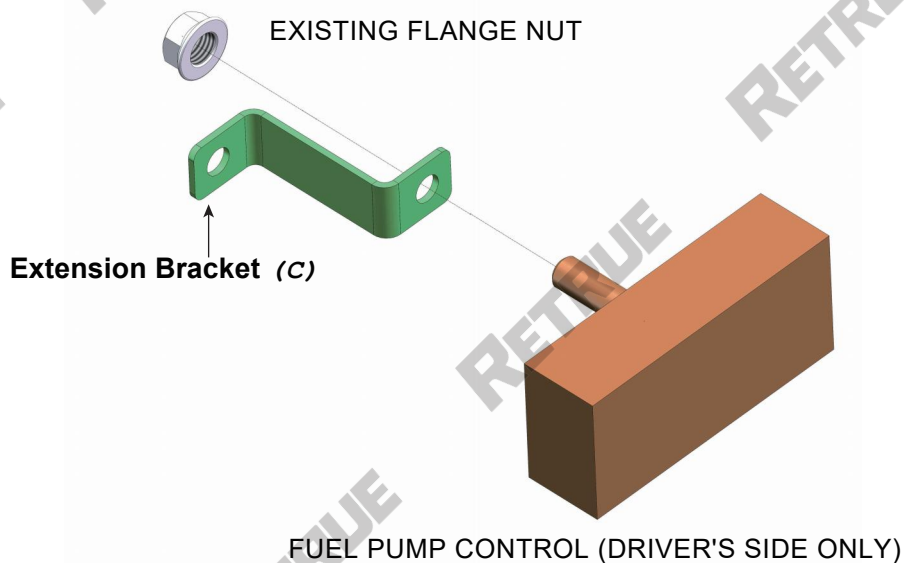

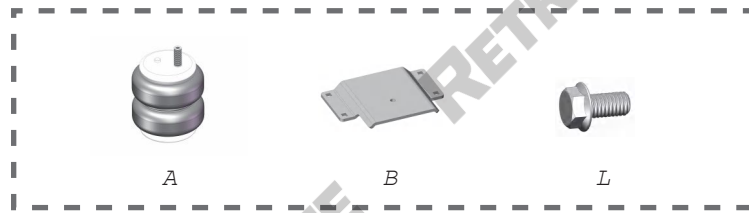

3

FASTEN THE AIR SPRING TO THE LOWER BRACKET

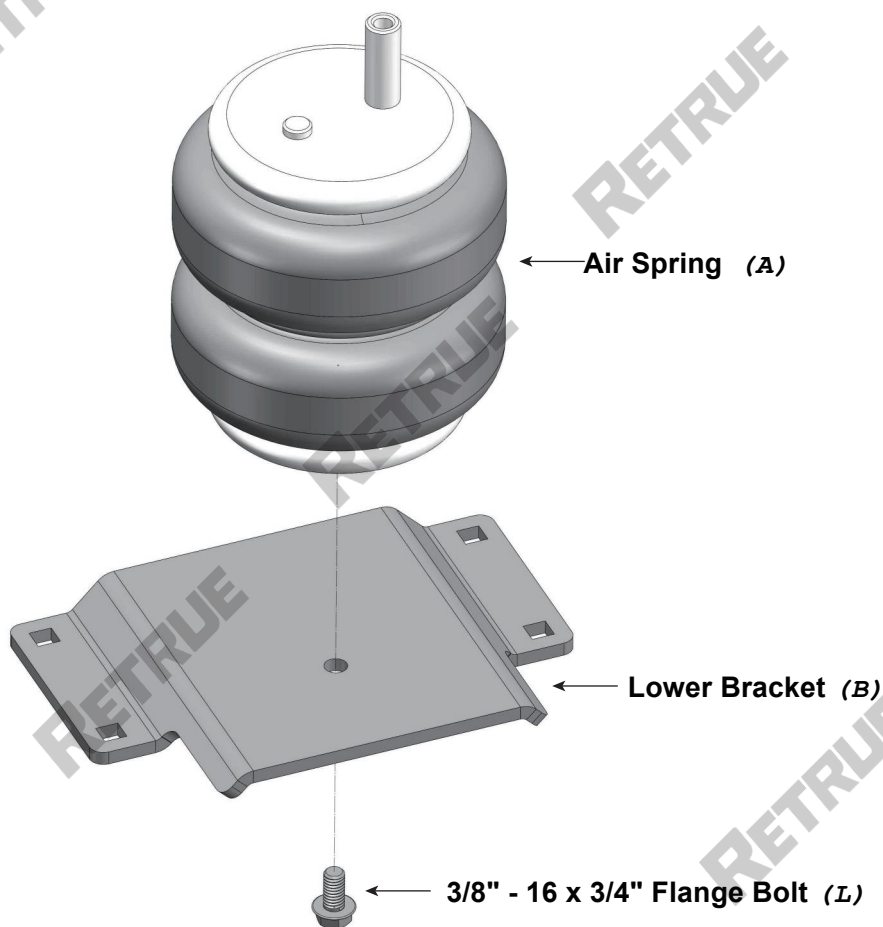

AT THIS STEP, PLEASE DO NOT COMPLETELY TIGHTEN THE BOLTS. TORQUE TO SPECIFICATION IN STEP 6.

4

PREPARE THE UPPER BRACKET

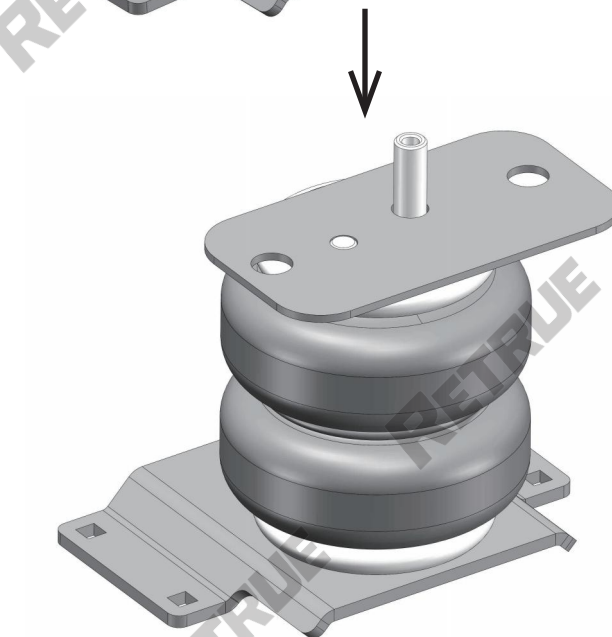
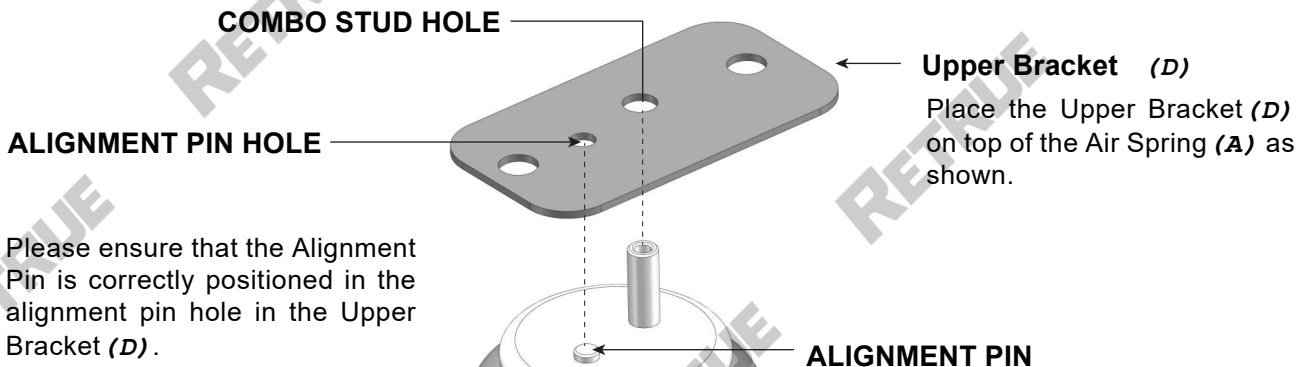
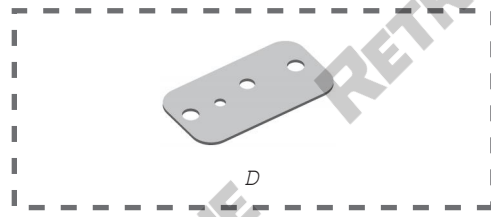

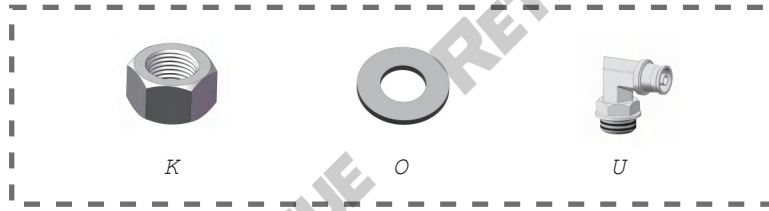

5 INSTALL THE AIR SPRING ASSEMBLY

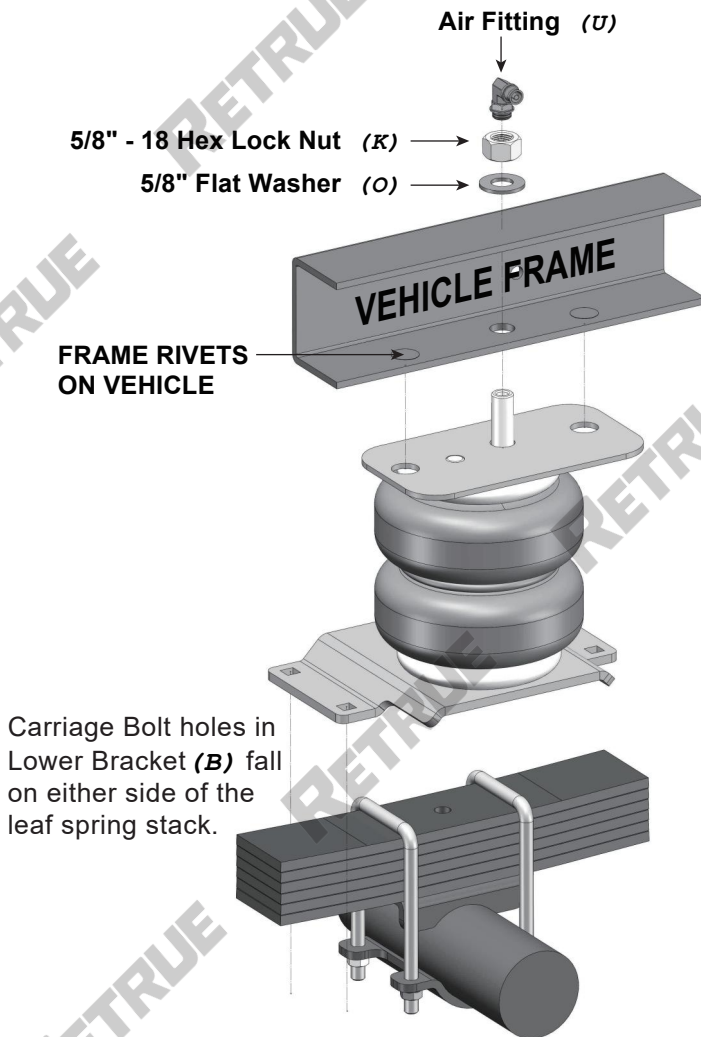

 THE EMERGENCY BRAKE BRACKET MAY NEED TO BE SLIGHTLY BENT TO ALLOW FOR ENOUGH SPACE.

1. Follow the guidelines below for dry assembly. Make alignment marks, as shown in the diagram.
2. Remove the assembly and match the alignment marks you have made.
3. Please fully tighten the 3/8"-16 x 3/4" Flanged Hex Head Bolts (**L**) on the bottom of the Lower Bracket (**B**).
4. Insert the combo stud on top of the Air Spring (**A**) into the hole in the vehicle frame.
5. Ensure that the two holes in the Upper Bracket (**D**) are aligned with the frame rivets on the vehicle.
6. Securely fasten the top of the Air Spring (**A**) and install the Air Fitting (**U**), as shown.

The bracket extension will contact the axle tube on most vehicles. Contact is not mandatory for proper operation.

 THE ALIGNMENT PIN ON THE AIR SPRING HAS TO BE INSTALLED INTO THE ALIGNMENT HOLE IN THE UPPER BRACKET. IF NOT, IT WILL CAUSE IT TO BE PUSHED INTO THE BEAD PLATE, CREATING AN AIR LEAK THAT WILL CAUSE THE AIR SPRING TO FAIL AND CANNOT BE WARRANTABLE. THE ALIGNMENT PIN CANNOT WITHSTAND 2,500 LBS! IT IS FOR ALIGNMENT ONLY!

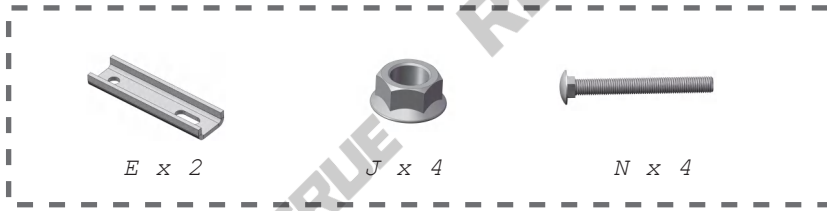

6

INSTALL THE LEAF STACK STRAP BRACKET

1. Insert Carriage Bolts (*N*) into holes in Lower Bracket (*B*).
2. Install the Leaf Stack Strap Bracket (*E*) onto the Carriage Bolts (*N*), under the leaf spring stack.
3. Fasten the Leaf Stack Brackets (*E*) to the Carriage Bolts as shown.
4. Check Air Spring (*A*) clearance and adjust if needed.

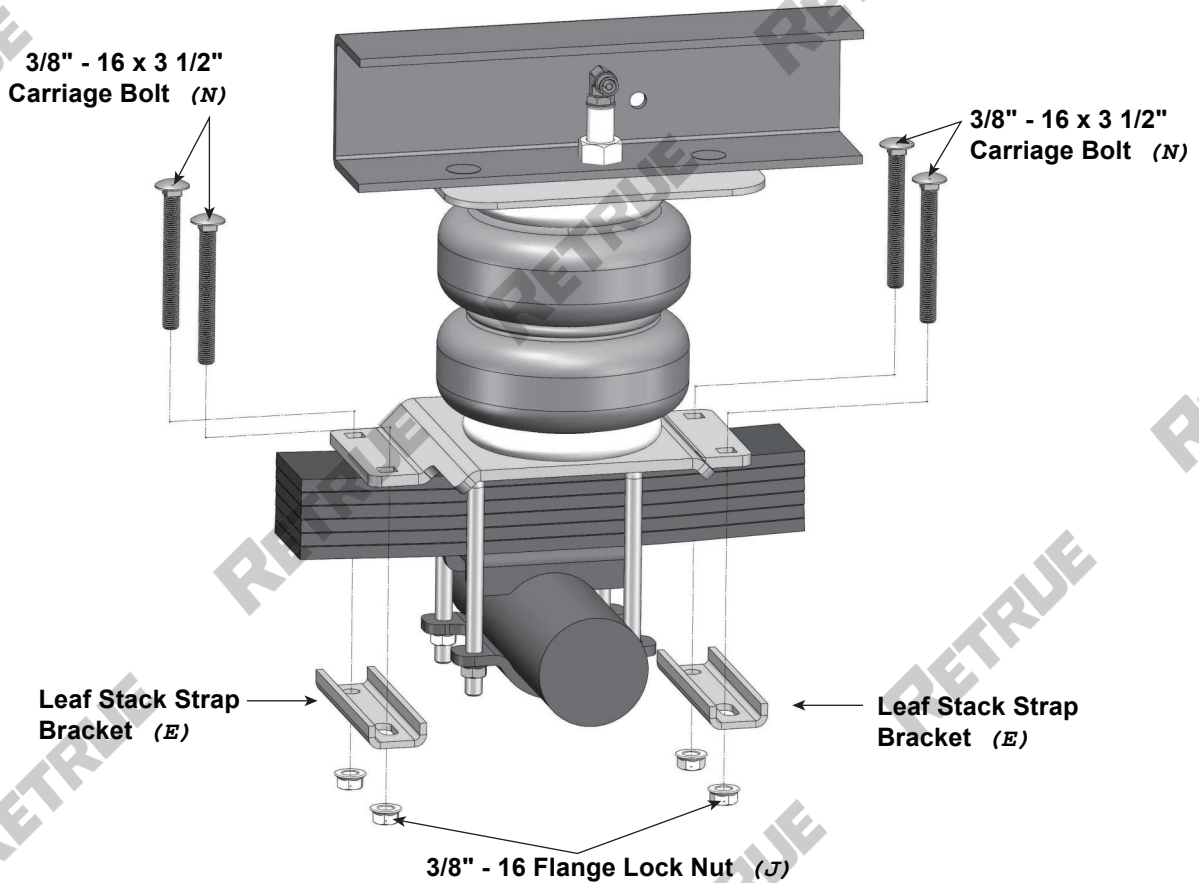

TIGHTEN THE FLANGE NUTS ALTERNATELY TO DRAW THE LEAF STACK STRAP BRACKETS EVENLY ONTO THE LEAF SPRING STACK.



PLEASE CHECK BY HAND IF THERE IS ENOUGH SPACE BETWEEN THE AIR SPRING AND OTHER COMPONENTS.

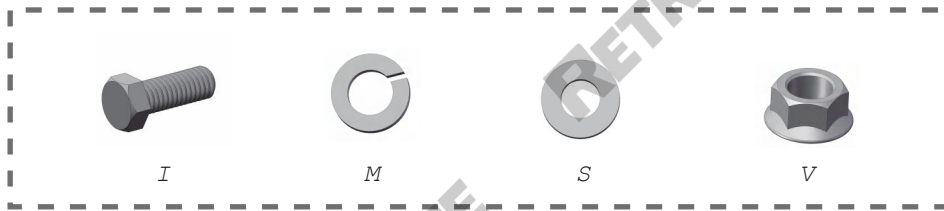

7

REINSTALL THE FUEL PUMP CONTROL

Use the shown fasteners to secure the fuel pump extension bracket to the hole in the vehicle frame.

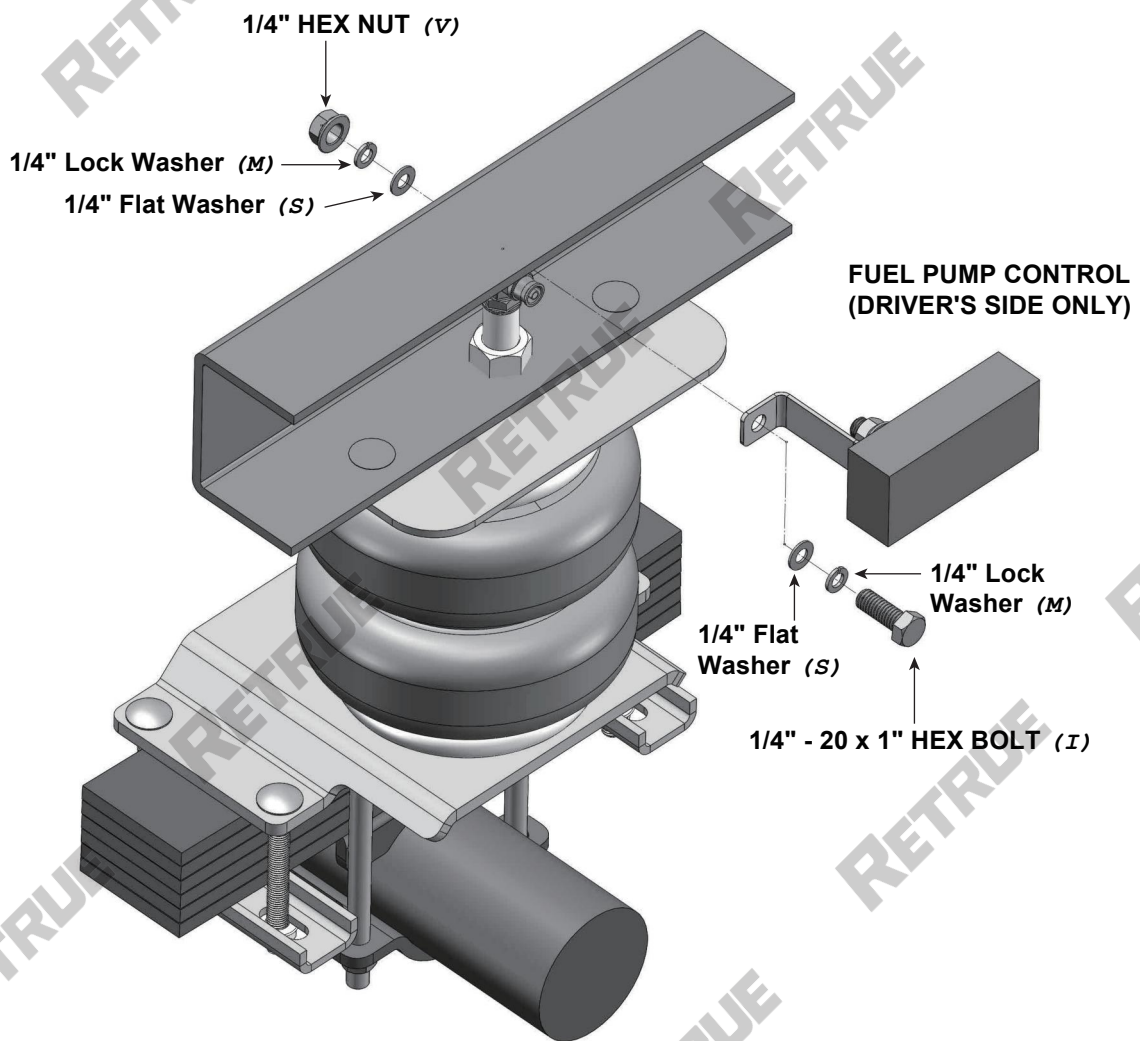

EXCELLENT. You're done with the driver's side. The passenger's side installation is the same, with the exception of the Fuel Pump Bracket. Go complete Steps 1-6 for the passenger's side, then continue to Step 8.

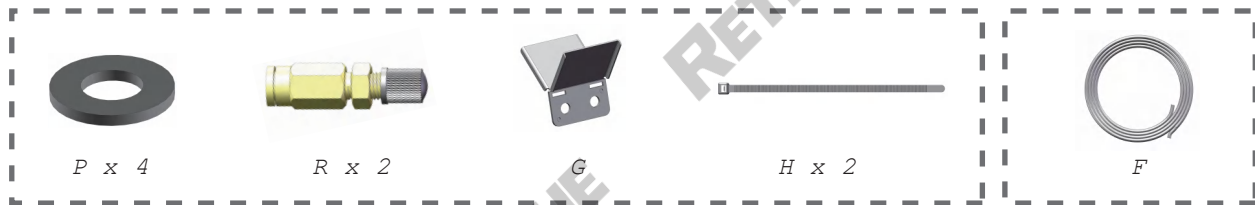

8 INSTALLATION OF INFLATION VALVES

IF YOU ARE USING THE OPTIONAL NO-DRILL INFLATION VALVE BRACKET, SELECT OPTION 1. IF YOU CHOOSE TO DRILL, SELECT OPTION 2. INFLATION VALVES MUST BE EASILY ACCESSIBLE BY AN AIR CHUCK.

1. Secure the Inflation Valve Bracket (G) to a protected and secure location.
2. Choose a protected location, such as the bumper or the body of the vehicle, to install the Inflation Valves (R). Drill two 5/16" holes for the Inflation Valves (R) installation locations.
3. Install the Inflation Valve (R) assembly as illustrated.

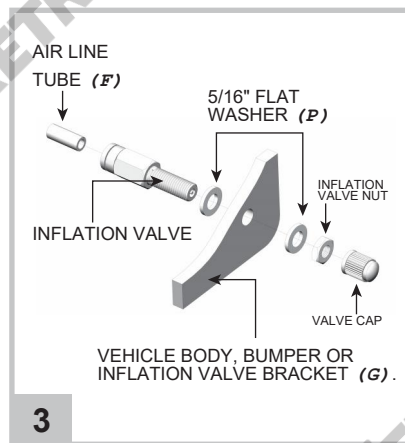
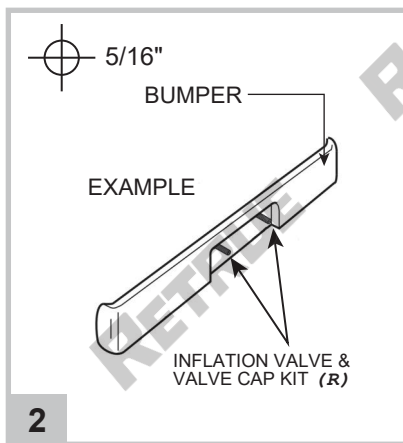
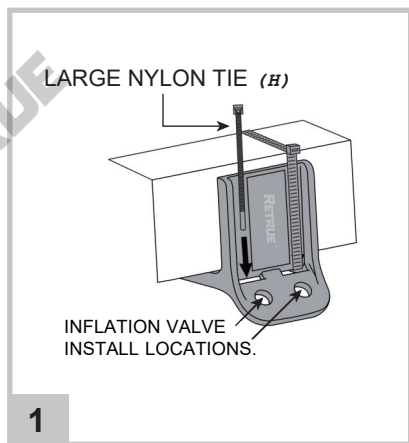

9 CUT THE AIR LINE TUBE INTO TWO EQUAL LENGTHS

Air Line Tube (F) Cutting: Follow these instructions to avoid leaks.

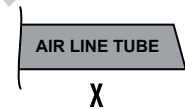
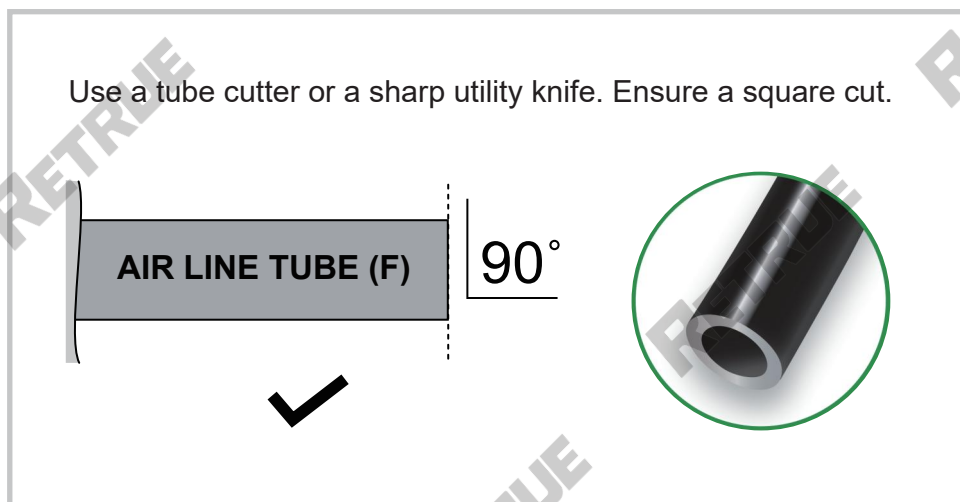

DON'T cut the Air Line Tube at an angle.

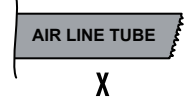

DON'T fold or kink the Air Line Tube.

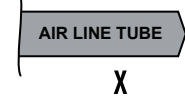

DON'T use pliers, scissors, snips, saws or side cutters.

10 INSTALL AIR LINE TUBE INTO AIR FITTINGS AND INFLATION VALVE

- 1 Insert the end of the Air Line Tube (F) into the Air Fitting (U).
- 2 Push the Air Line Tube (F) into the Air Fitting (U) as far as possible.
- 3 Gently pull on the Air Line Tube (F) to ensure a secure fit.
- 4 To remove and push down the collar and gently pull the Air Line Tube (F) away.

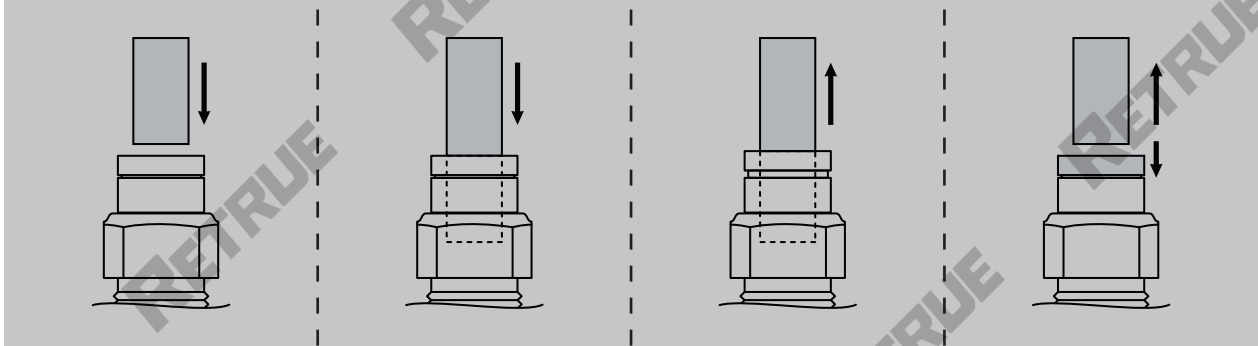

REMOVAL TIP: USE A 1/4", 5/16", OR 6MM OPEN-ENDED WRENCH TO PUSH THE COLLAR DOWN.



11 ROUTE AND SECURE AIR LINE TUBES

The routing of Air Line Tubes (F) will vary based on your truck, and it is essential to choose the optimal path from the Air Springs (A) to the Inflation Valves (R). Follow the instructions below for guidance.

DO

1. Select routes that are shielded from heat, debris, and sharp edges.
2. Utilize Thermal Sleeve (T) near heat sources.
3. Secure the Air Line Tube (F) using Small Nylon Ties (Q).

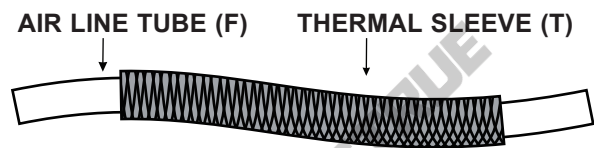

USE THE SUPPLIED THERMAL SLEEVE (T) WHEN THE AIR LINE TUBE (F) RUNS WITHIN 6 INCHES OF HEAT SOURCES.

DON'T

1. Bend or sharply curve Air Line Tubes (F).
2. Leave Air Line Tubes (F) exposed to sharp edges.
3. Use unnecessary lengths of Air Line Tube (F).
4. Route Air Line Tubes (F) near moving parts.
5. Allow Air Line Tubes (F) to hang unsecured from the vehicle.

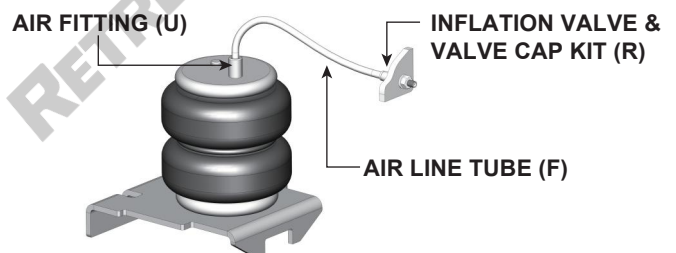

12

FINISH THE INSTALLATION & CHECKING

SAFELY RETURN VEHICLE TO OPERATIVE STATE

1. If you removed any wheels during installation, install the wheels and torque the lug nuts to the manufacturer's specifications.
2. Safely remove any jack stands and wheel chocks used during installation.
3. Re-attach the negative battery cable.

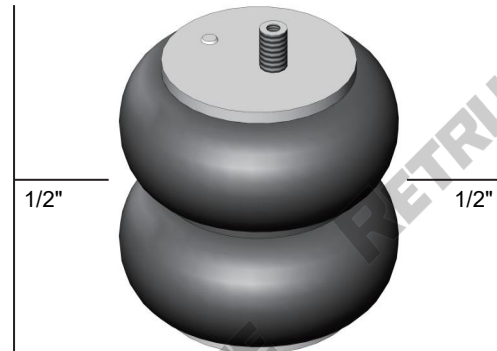

USE YOUR HAND TO CHECK FOR THE PROPER CLEARANCE AROUND THE AIR SPRING (A). IF YOUR HAND DOES NOT FIT BETWEEN THE AIR SPRING (A) AND OTHER COMPONENTS, IT WILL RUB!

INSTALLATION CHECKLIST

• CLEARANCE TEST:

Inflate the Air Springs (A) to 75-90 PSI (4.8-6.2BAR) and ensure a minimum clearance of at least 1/2" (13mm) from any potential rubbing surfaces, including tires, brakes, frame, shock absorbers, and brake cables.

• LEAK TEST BEFORE ROAD TEST:

Inflate the Air Springs (A) to 75-90 PSI (4.8-6.2BAR) and thoroughly inspect all connections for leaks. Address and eliminate any leaks before conducting a road test.

• HEAT TEST:

Confirm adequate clearance of at least 6" (152mm) from heat sources for both Air Springs (A) and Air Line Tubes (F).

• FASTENER TEST:

Double-check all bolts for proper torque.

• ROAD TEST:

After completing the preceding tests, road test the vehicle. Inflate the springs to the recommended driving pressures, drive the vehicle for 10 miles (16km), and recheck for clearance, loose fasteners, and air leaks.

• OPERATING INSTRUCTIONS:

If professionally installed, review the operating instructions with the owner. Provide the owner with all the paperwork included in the kit.

WARNING TIPS

■ SAFETY WARNING

Do not exceed the manufacturer's specified gross vehicle weight at any time, Air Spring assist devices can fail due to some reason such like puncture, impact damage, improper inflation, improper installation, or improper use. Please make sure Never Overload Your Vehicle. An installed Air Spring in the inflated state should not touch any other part of the vehicle under normal suspension operation. Air Springs need to be flex and expand while operating. Make sure there is at least a 1/2" clearance between the Air Springs and other parts of the vehicle in the normal suspension state. If you have any questions please feel free to contact us at retrue.com.

Please ensure that the distance between the device and the exhaust system cannot be too close. If the distance between the device and the exhaust system is less than 6 inches, please install heat insulation devices, such as Thermal Shield. Do not inflate the Air Springs exceed the maximum pressure indicated in the manual. Any part of the device has its corresponding function. Please do not disassemble any part when the device has been inflated. If this device fails while you are driving please reduce your speed slowly and park in a safe place and call us immediately. Please do not drive at high speed on rough roads. Unleveled heavy loaded vehicles can cause serious damage. For your safety if any malfunction of this device please contact us and operate under the guidance of our professional technicians, please do not repair without guide.

■ GENERAL INFORMATION

RETRUE Air Springs are designed to complement your existing suspension system. Installing and using this product in the manner described here will give you the most durability and best condition.

■ BASIC OPERATION

The original suspension system is designed set for you to provide stable performance for your vehicle at a specific load range. When your vehicle is heavily loaded, the stability and drivability of your vehicle will be affected. Our Air Springs can help you with these problems, as the pressure increases, the Air Spring absorbs more air to supplement its support, but we strongly recommend that you never exceed the vehicle manufacturer's load limit.

■ PREVAILING-TORQUE LOCK NUTS

Be aware the maximum volume of Air Springs is way less than the tire's. Please check the air pressure frequently when you are inflating the Air Springs.

TABLE "A"
ALL TORQUE SPECIFICATIONS

Using a torque wrench, torque the threaded fasteners to the following specifications:

Fasteners used on studs and blind holes in Air Springs	15 – 20 ft lbs
Hex nuts installed on carriage bolts	10 – 15 ft lbs
Hex nuts installed on 3/8" hex bolts	28 – 32 ft lbs
Hex nuts and bolts used to secure brackets to frame	28 – 32 ft lbs
Hex nuts installed on U-bolts	15 – 20 ft lbs
Hex bolts securing tapered sleeve style Air Spring to lower bracket	10 – 12 ft lbs

■ THREAD LOCKING COMPOUND

It is used to secure the Air Spring, please follow the instructions to install and use it correctly.

■ HELICAL LOCK WASHERS

Please follow the instructions to install and apply properly. Press the nut/bolt fastener just enough flat against the lock washer, too tight may damage the part. Please check TABLE A for all TORQUE SPECIFICATIONS.

■ AIR FITTINGS

The kit includes the Air Fitting, please install it properly. Your kit will contain Air Fittings with nylon rings in place of the thread locking compound with the nylon collar, screw the Air Fitting into the threaded hole in the Air Spring so that the nylon collar makes contact with the top of the Air Spring and then tighten 1/2 turn. No thread sealant is required. The Air Fitting allows for easy connection of the Air Fitting to the air line pipe. To install the air line in the tube, use a sharp utility knife or razor blade to cut the tube as square as possible. Push the air line into the tubing as far as possible. If the tube must be removed from the tubing, first release the air pressure from the Air Spring. Push the collar into the body of the holder and pull the tube out.

■ PRESSURE DIFFERENTIAL BETWEEN AIR SPRINGS

It is common for the pressure in two Air Springs to vary for many reasons. But if the vehicle is within the maximum manufacturer's recommended gross vehicle weight and the air pressure is reached 100 PSI, the vehicle is still not in a level status, it may have a problem with the vehicle's suspension system. Please check your vehicle's stock suspension system to make sure it is all good.

■ AIR SPRING ALIGNMENT AND HEIGHT

After installing the Air Spring, please check again that the Air Spring is installed in the correct position. For safety reasons in our design, in some situations, the Air Spring still can work even if it is misplaced, but we still recommend that you make sure it is in the correct position. The position of the Air Spring after proper installation is described on Page 14 of the manual.

■ INFLATING THE AIR SPRINGS

After installing the Air Springs, please park your vehicle on a level surface, then you can inspect if the vehicle is in a level state. If it is not in a level state (either front to back or side to side, you can inflate the Air Springs till it is level. Our Air Springs each have their own separate Inflation Valve. Please add air pressure in small quantities and check the air pressure frequently while inflating the Air Springs. Please note the Air Springs require way less air volume than a tire. Last but not least, never exceed the maximum air pressure that indicated in the instruction.

■ MAINTENANCE

This is normal, Air Springs will lose some air pressure over time. When the Air Springs are inflated to 50 PSI, it should not lose more than 3-4 PSI per week, if it does, please check if there is a leak. Please note it will cost 1-3PSI each time you check the system. We recommend you check the air pressure frequently, also before when you are going to drive the vehicle for a long trip or through uneven roads, when the vehicle is free from long time storage. Ensure that the threaded fasteners are torqued to the specifications listed on Page 15 (TABLE A). Whenever you wash your vehicle, please also wash the exterior of this Air Spring. Release the air pressure from the Air Springs if you need to lift the vehicle to avoid damage to the Air Spring system.

RETRUE

YOUR RELIABLE PARTNER

AIR HELPER SPRING

TROUBLE SHOOTING GUIDE

Thanks for you choose **RETRUE** Air Helper Springs. This guide is regarding the use and operation of the Air Springs. It will help you go through many questions about daily use and air pressure requirements, maintenance. Please keep this manual for your convenience.

For more questions you can just reach us at

retrue.com

TO INSTALLER

Please leave this manual with the vehicle's owner.

TROUBLE SHOOTING GUIDE

■ AIR SPRING WILL NOT INFLATE

Check that the Air Line Tube are not damaged or knotted, and clean the tube of dirt and debris. Make the Air line tube insert into the Air Fittings as far as possible. It should go in 3/4 inch.

■ AIR SPRING WILL NOT HOLD AIR

It is quite normal that the Air Spring will lose some air pressure over time. Normally, when the Air Spring is inflated to 50PSI, its weekly air pressure loss should not exceed 3-4PSI. If abnormal pressure loss rate is detected, there may be a leak in the system, you can inflate the Air Spring and put it in water to detect the location of the leak.

■ LOCATIONS OF AIR LEAKS

Leakage most often occurs at the threaded connection between the Air Fitting and the Air Spring. Tighten the fitting until the nylon sleeve contacts the Air Spring and add 1/2 turn.

Please note that the end of the Air Line Tube must be cut squarely and cleanly enough to avoid burrs occurring in the connections of Air Fittings. Push-in fittings must be cut square to ensure sealing. Make sure to exhaust all air from the system before releasing the Air Line Tube from the Air Fitting. Then remove the tube from the fitting, push the collar on the fitting into the fitting body, and pull out the tubing while holding the collar. Cut the tube as square as possible and push the tube into the fitting as far as possible.

■ THE VEHICLE IS NOT LEVEL

Check that the Air Springs on each side are properly inflated and the suspension system is not faulty and that there are no obstacles in the suspension system.

IMPORTANT

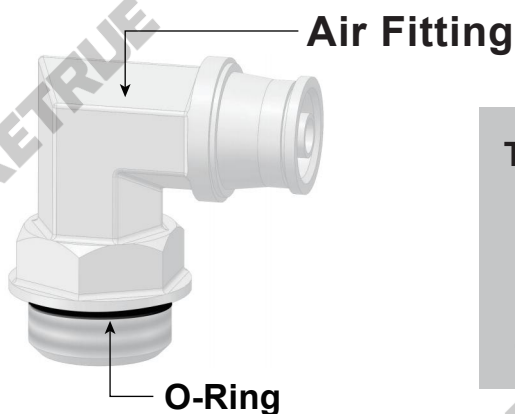

THE O-RING IS FOR SINGLE USE ONLY!

UNSCREWING AIR FITTING AFTER IT HAS BEEN TIGHTENED WILL LEAD TO FAILURE, REQUIRING REPLACE A NEW O-RING TO PREVENT LEAKS.

WARRANTY GUIDELINES

- Warranty period is determined by date of shipment from **RETRUE** Co.,Ltd. for factory direct purchases or date of purchase from an authorized reseller. Please save a copy of your purchase receipt.
- If this product or any associated parts are found to be defective or missing at the time of receipt, **RETRUE** Co.,Ltd will repair or replace, at its option, the defective parts at no charge to the original purchaser. Replacement parts or repaired parts shall be covered for the remainder of the Original Limited Warranty Period. All shipping costs will be the responsibility of the seller.
- Continuous free technical support is provided, including online diagnosis and troubleshooting to users' problems, and come up with solutions in time. In order to process your claim, please upload a copy of your receipt along with AT LEAST 2 photos of the issue/damaged parts. Otherwise, supplier reserves the right to refuse replacement parts or credit.

If a warranty claim is made after 30 days after purchase for missing or defective parts, the consumer is responsible for costs of parts and shipping.

- **RETRUE** Co.,Ltd. reserves the right to the final explanation of above warranty policy. Please contact our Customer Service via email: contact@retrue.com for more information.

What is not covered by this limited warranty?

- Item past the warranty.
- Products that has been subjected to abuse, overweight, accident, alteration, modification, tampering, vandalism, negligence, misuse, abrasive contact, faulty installation or lack of reasonable care.
- Damage to the contents of products, any person or property is excluded. Normal and foreseeable service wear or tear.
- Parts damaged due to improper installation or assembly.
- Damage that occurs due to acts of nature, i.e. hurricane, tornado, wind, flood, snow, wind driven debris, etc.
- Third party labor or installation fees of any kind are not recoverable under the warranty.
- Other circumstances stipulated by law.

DISCLAIMER

1	The Air Helper Spring Kit is designed to enhance the handling and comfort of your vehicle; Please learn where and how they are correct used.
2	The user assumes all responsibility and liability for the safe operation of the Air Helper Spring Kit.
3	The manufacturer, distributor, and seller of the Air Helper Spring Kit shall not be held liable for any accidents, damages, injuries, or losses arising from the use or misuse of the product.
4	It is the user's responsibility to regularly inspect the Air Helper Spring Kit for any signs of damage, wear, or defects and take appropriate measures to repair or replace it.
5	The Air Helper Spring Kit should only be used in accordance with the manufacturer's guidelines and recommendations.
6	Any modifications or alterations to the Air Helper Spring Kit without the manufacturer's approval may void any warranties and increase the risk of accidents.
7	The user should consult the Air Helper Spring Kit manufacturer's manual and seek professional advice regarding the vehicle compatibility and installation of the kit.
8	The information provided in this safety instruction and disclaimer is for general guidance purposes only and does not substitute proper training, adherence to regulations, and individual judgment in ensuring safety.

Note: This safety instruction and disclaimer are provided as a general example. It is essential to consult legal professionals and industry experts to create accurate and legally compliant safety instructions and disclaimers for specific products and jurisdictions. The use of any equipment, including this one, involves the potential risk of injury. Except for any warranty claim that may be made for a proven defect in the material or workmanship of the product, you acknowledge and assume full responsibility for any and all injuries, damages (both economic and non-economic), and losses of any kind that may occur. You hereby release and discharge **RETRUE**, its insurers, employees, officers, directors, associates, and agents from any and all present or future claims, demands, damages, rights of action, or causes of action, whether known or unknown, anticipated, or unanticipated, arising from or related to the use of said equipment. This equipment must be used with care by capable and competent adult individuals, under professionals if necessary.

CONTACT INFORMATION

RETRUE, a self-owned factory brand, has over 30 years of manufacturing experience in RV, pickup, and outdoor accessories. With a focus on innovation and reliability, we prioritize customer-centric values. "Your Reliable Partner" signifies our dedication to delivering durable, dependable products to customers. **RETRUE** where craftsmanship meets customer companionship and a commitment to safety, strength, and sustainability prevails.

Please contact us with any comments, questions or suggestions that you may have by sending messages or emails. All the mails will be replied within 24 hours. Please ensure your mailbox would not block/filter our mails. We will surely give you a satisfactory service.

Web Address

www.retrue.com

Email

contact@retrue.com

RETRUE Co.,Ltd. reserves the right to make changes and improvements to its products and publications at any time. For the latest version of this manual, email contact@retrue.com

 California: WARNING: Cancer and Reproductive Harm – www.P65Warnings.ca.gov