

AQUAFINE

LOGIC™ Series

System of choice for meeting rigid quality standards in Industrial applications





A Robust, Versatile and Cost-effective UV System. Proven Low-Pressure, High-Output Amalgam Lamp Technology.

The system of choice for meeting the rigid quality standards of the Recreational Water, Life Sciences, Pharmacy, Cosmetics and Food & Beverage markets. The Aquafine UV Logic Series uses one of the most advanced technologies, the low-pressure, high-output (LPHO) amalgam lamp. The Aquafine UV Logic Series is equipped with a UV chamber made of 316L stainless steel and

a 304SS stainless steel control cabinet with protection class IP 55. The L-shaped chamber design was developed using advanced computer modeling, resulting in 40% greater hydraulic efficiency than conventional systems.

The compact size maximizes installation flexibility and preserves floor space.

Single ended lamps and quartz sleeves allow fast lamp change-outs, and features automatic sleeve cleaning that can be operated while the chamber is online. Each system undergoes rigorous quality checks and electronic functionality and hydrostatic pressure testing before leaving our facility.

Ultraviolet (UV) Technology in Your Treatment Process

Ultraviolet (UV) light is a versatile, reliable approach to address numerous requirements in industrial water treatment.

UV for Broad-based Treatment

- The Aquafine Logic treats the following: Escherichia coli (*E. coli*) and fecal coliform.
- 254 nm UV penetrates the cell wall of microorganisms, attacking DNA genetic material and preventing replication
- No carcinogenic treatment by-products are created, and no transportation, storage or handling of toxic or corrosive chemicals is necessary

UV for Ozone Reduction

- Residual ozone (O₃) is efficiently removed by UV at a wavelength of 254 nm
- Ozone absorbs the UV energy and quickly breaks down to dissolved oxygen (O₂)
- Typically 1.0 ppm of ozone can be reduced to less than 0.1 ppm with a UV dosage of 90 mJ/cm²

UV for Chlorine Reduction

- UV to break down free chlorine even with high chloramine values
- Reduces carcinogenic by-products
- Lower maintenance costs compared to carbon beds or chemical injections

The Benefits of UV

Broad-spectrum, cost-effective protection

- Widely accepted and endorsed worldwide for treatment of drinking water
- Does not create by-products (DBPs) and does not affect taste
- At approximately 1/5th the cost of ozone treatment and 1/10th the cost of membrane filtration, UV is the most cost-effective approach for multi-barrier treatment strategies

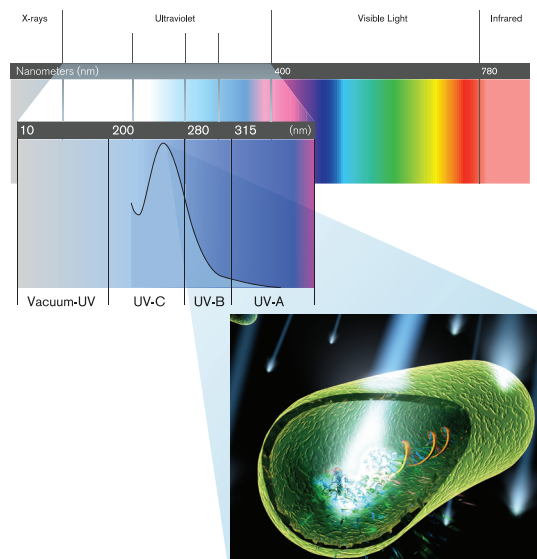

INDUSTRIES: Aquaculture, Food & Beverage, Life Sciences, Microelectronics, Recreational Waters, Pharmacy and Cosmetics

FLOWRATES: 350-5895 GPM @ 95% UVT, 430-5895 GPM @ 99% UVT

APPLICATIONS: Treatment, Chlorine/Chloramine Reduction, Ozone Reduction

DESIGN CAPABILITIES: Custom Configurations or Skid Capabilities

UV Sensor

Highly accurate, photodiode sensor monitors UV output within the chamber. Mounted within the sensor port on the side wall for easy access.

UV Chamber

Type 316L stainless steel. Chamber configurations are available with multiple inlet/outlet diameters. Rated to 150 PSI (10 BAR). A drain port is located opposite the outlet flange.

Amalgam Lamps

Utilizes high-output amalgam lamps. Each is located within its own protective quartz sleeve and supported by a removable, sleeve holder assembly. Designed for easy lamp replacement.

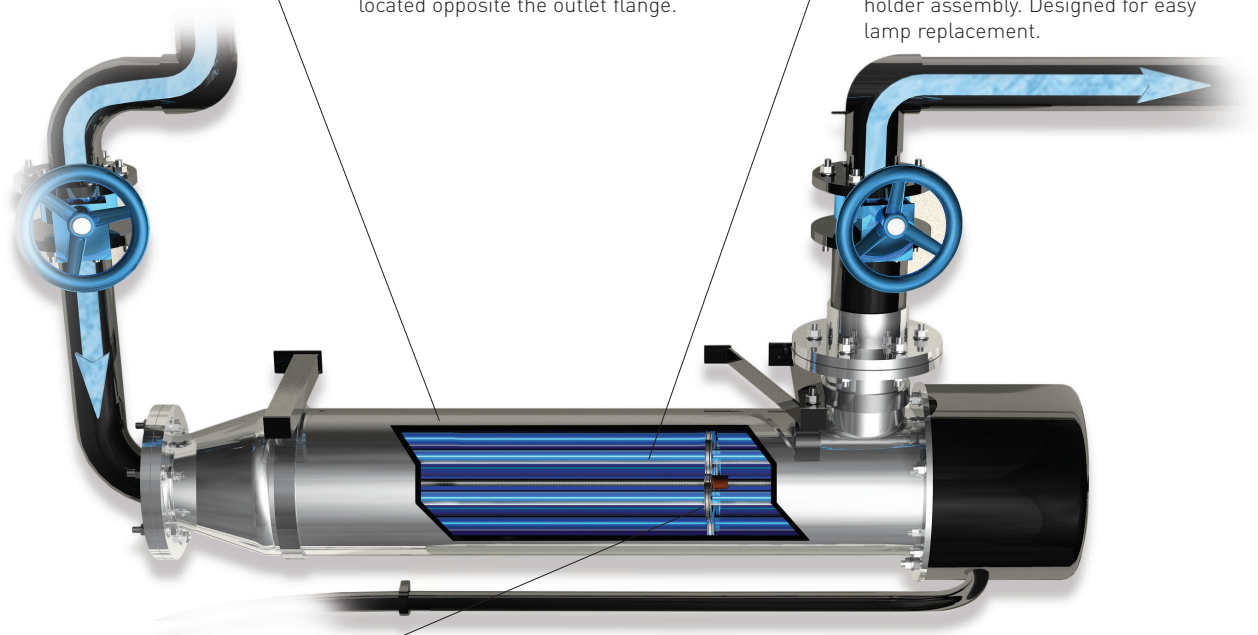

Sleeve Wiping System

Automatic wiper system; able to operate online, without interrupting treatment. The automatic system allows cleaning at preset intervals using a motor-driven wiper assembly.

Remote Monitoring & Control

Robust microprocessor-based controller provides standard I/O signals for on/off control from a remote location. Programmable digital and analog I/O capabilities can generate unique alarms for individual applications, and send signals to operate valves and pumps. All units feature optional SCADA communication via Modbus, Modbus TCP/IP, EtherNet/IP and PROFINET.

Control Panel (CP)

304 Stainless Steel Cabinet is designed, for indoor, wall-mount installation. Houses a controller with customer connection points, and electronic power supplies. Distributes power to the UV chamber as well as the UV sensor and optional automatic wiping system. UV intensity, lamp elapsed time and lamp status are continuously monitored and displayed on the operator interface, located on the control panel door.



Key Benefits

Aquafine Logic

Assurance of NSF 61 and proven performance. Meets the stringent standards of NSF International.

Compact footprint for installation flexibility. Can handle maximum flow capacity in minimal space. Its compact design allows it to be installed in restrictive spaces, thereby lowering installation costs. Where approved by local regulators, the system can even be installed immediately after a 90° elbow and other upstream piping configurations.

Fewer lamps required to treat a given flow. High-intensity amalgam lamps minimize the lamps, seals, and maintenance to meet dose delivery requirements.

Sleeve wiping system reduces maintenance costs. Equipped with a highly-effective fully automated sleeve wiping system to minimize the frequency and costs of cleaning. Sleeve wiping works while the UV unit is online and working.

Designed for maximum operating efficiency. High-efficiency, electronic lamp drivers ensure cost-effective operation. Our high-capacity models reduce operating costs and extend lamp life.

Local service. Global support. Our comprehensive network of certified service providers offers ongoing maintenance programs and fast response for service and spare parts.

Guaranteed performance and comprehensive warranty. Our systems include a Performance Guarantee and comprehensive protection for your investment.

Compact Chamber for Installation Flexibility

Efficient, cost-saving design

Benefits:

- Compact footprint simplifies installation and minimizes related capital costs – making it ideal for retrofit applications into existing water treatment plants
- Engineered to fit into restrictive pipe galleries
- Lamps and quartz sleeves are fully serviceable from one side – allowing the system to be installed tight to walls, other equipment or piping
- “L-shaped” design is 40% more efficient than “U-shaped” systems
- Low head loss design simplifies integration into existing processes, and minimizes the need for additional pumps and their associated capital and operating costs
- Wall-mounted control panel can be located up to 82' (25 m) from the chamber

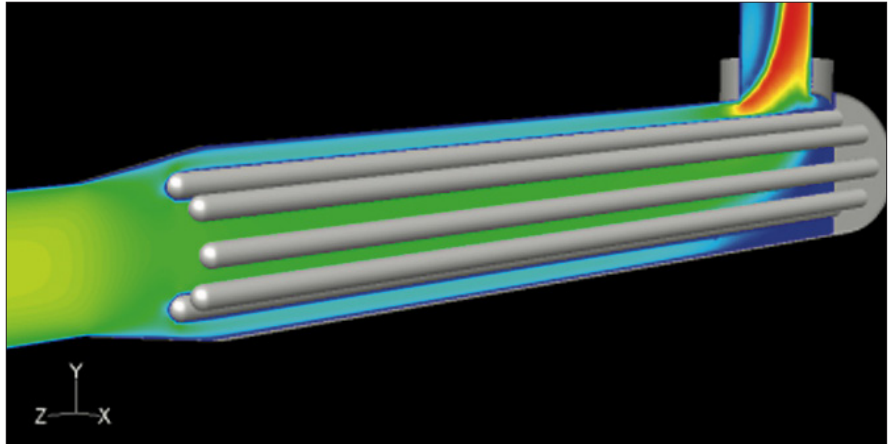

The highly efficient “L-shaped” design and low-pressure, high-output (LPHO) amalgam lamps result in an extremely compact footprint.

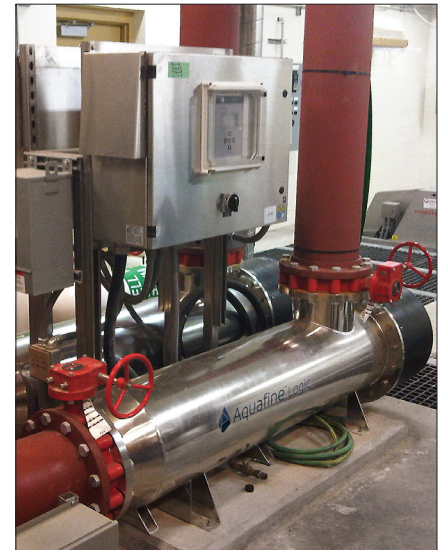

Developed using advanced Computational Fluid Dynamic (CFD) modeling, and incorporating high-output amalgam lamps, the Aquafine Logic is extremely space-efficient. Its compact footprint allows the system to be integrated into restrictive pipe galleries of water treatment facilities.



Energy-Efficient, High-Output Amalgam Lamps

Fewer lamps reduces capital and O&M costs

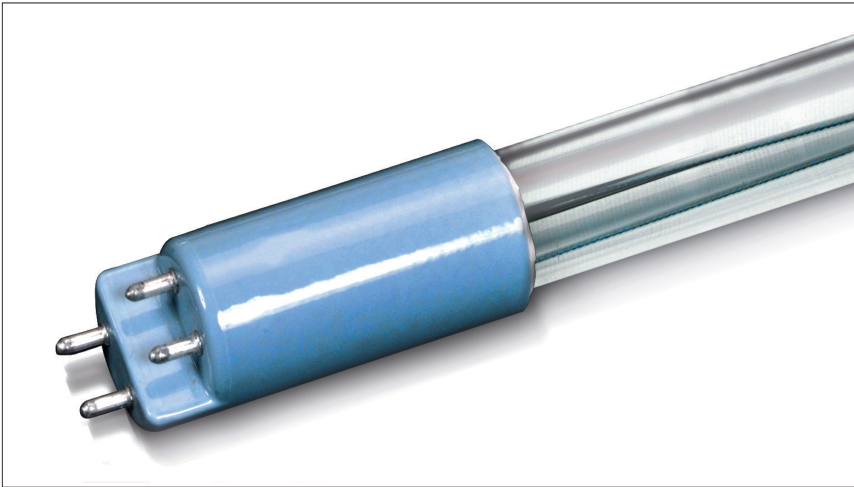

Efficient, LPHO amalgam lamps allow Aquafine Logic systems to deliver the required UV dose with fewer lamps and lower operating costs.

Benefits:

- The Aquafine Logic requires 1/2 to 1/3 fewer lamps to deliver the required dose compared to traditional UV systems using low-pressure lamps
- With fewer lamps, the Aquafine Logic is very compact and can be installed in small spaces
- Fewer lamps means reduced annual maintenance costs for lamp change-outs



Robust Sleeve Wiping System

Automatic wiping ensures consistent dose delivery

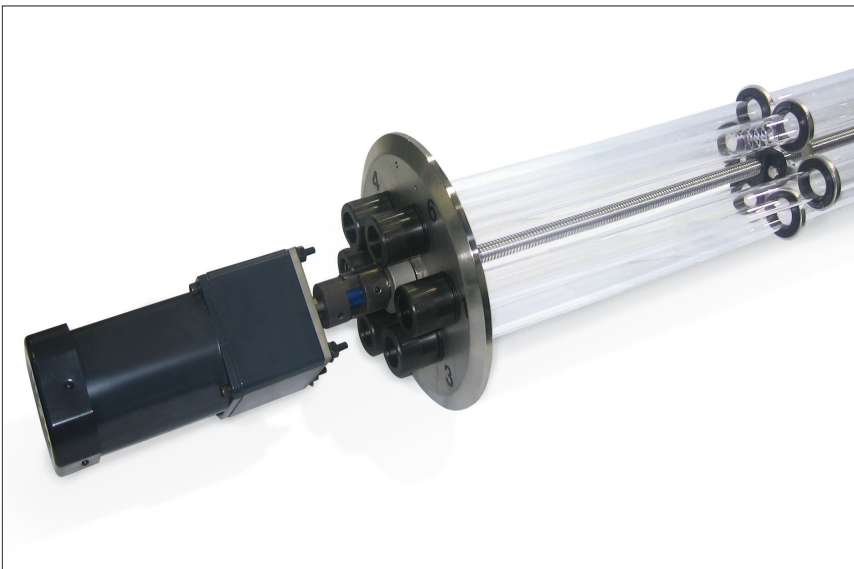

The automatic wiping system reduces maintenance costs. The motorized system (shown above) can be programmed to wipe automatically at preset intervals.

** Image shown for illustration purposes only. See Aquafine or an Authorized Distributor for details.*

Benefits:

- Wiping system minimizes fouling of the quartz sleeves
- Ensures consistent UV dose delivery for maximum effectiveness
- Operates online while the lamps are working, reducing downtime
- Can be programmed to wipe lamp sleeves at preset intervals

User-Friendly Digital Controller

Intuitive system provides at-a-glance system status and allows remote operation



The Aquafine Logic controller and high-efficiency electronic ballasts have been proven in thousands of installations. The Control Panel features a user-friendly digital interface, and can be mounted up to 82 ft (25 m) from the chamber.

Benefits:

- Robust, microprocessor-based controller combines extensive functionality with an operator friendly, digital interface
- Display provides at-a-glance, real-time system status information
- Programmable digital and analog I/O capabilities allow remote on/off control and alarm code differentiation for fast identification of changes in system status
- Optional Modbus, Modbus TCP/IP, EtherNet/IP and PROFINET protocols communicate with plant SCADA system for centralized monitoring of UV performance, lamp status, power levels and other parameters

Designed for Easy Maintenance

Operator-friendly design for easy routine maintenance



The Aquafine Logic design simplifies maintenance procedures. For example, lamp change-outs require no tools and take less than five minutes per lamp.

** Image shown for illustration purposes only. See Aquafine or an Authorized Distributor for details.*

Benefits:

- Single-ended UV lamps simplify replacement
- Lamps require less than five minutes each to change
- Externally-mounted sensor allows easy access
- Automatic sleeve wiping system reduces the frequency, inconvenience and cost of manual cleaning