

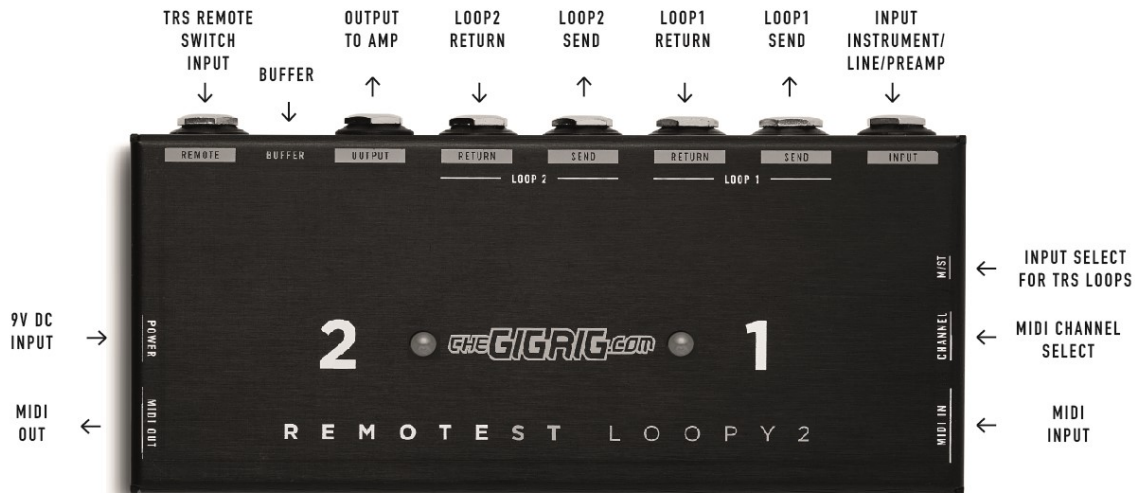

RE MOTEST LOOPY 2 MANUAL

TheGigRig Remotest Loopy2

TheGigRig Remotest Loopy2 enables you to add two extra effects loops to your pedal board and switch them in and out using either a simple TRS remote switch (such as the Remote Switches in G3) or control the loops using MIDI. Best of all, you can use the Remotest Loopy 2 in mono or stereo using TRS leads and it includes a switchable post effects-loop mono/stereo buffer.



Remotest Loopy2 Connections

INPUT: The main signal input. For stereo signals from the input use a TRS cable

LOOP1 SEND: Sends the mono/stereo signal to the input of your effect

LOOP1 RETURN: Connect the output of the effects that you want in LOOP1 here

LOOP2 SEND: Sends the mono/stereo signal to the input of your effect

LOOP2 RETURN: Connect the output of the effects that you want in LOOP2 here

OUTPUT: The main output signal

BUFFER: This switch turns on a stereo buffer post effects loops. Left – ON, Right - OFF

REMOTE IN: You can remotely switch the Remotest Loopy2's loops by using any dual latching switch including G3's remote switches. This is a TRS connection

POWER: 9V Centre Neg 2.1 mm connection @ 150mA

M/ST: This switch selects the input state when using TRS loops. ST is the standard configuration for using all MONO loops or all STEREO loops.

INPUT/LOOPS: If you have a mono input but want to use stereo TRS loops select the M state

CHANNEL: Selects the MIDI input channel from 1 to 16

MIDI IN: Receives MIDI signal via standard 5 pin din

MIDI OUT: Reflects the MIDI IN signal directly through

In Operation

The Remotest Loopy2 has 2 passive effects loops in series that can be either MONO or STEREO. You can place the Remotest Loopy2 anywhere in your rig where you want to add 2 extra loops. For example, place it at the start of your pedal board to add two mono loops at the front, or place it right at the end of your signal path to have two extra loops after everything else. You can switch the loops using either a simple TRS remote switch or with MIDI using either PC or CC messages. The switchable stereo buffer sits after the effects loops so you can keep the loop signals passive which works great for fuzzes effects that have a sensitive input. Now you can choose if you want the signal post loops to be buffered or not. This is a true stereo buffer so if you are using stereo effects, you have a separate buffer for you left and right signals.

MIDI

The Remotest Loopy2 enables you to control its loops using both PC and CC MIDI messages.

* Set your desired MIDI input channel using the channel select rotary encoder. 1= channel 1, 2= channel 2, etc. A= channel 10, B= channel 11, C= channel 12, D= channel 13, E= channel 14, F= channel 15, 0= channel 16

* Send the Remotest Loopy2 the desired MIDI message

Program Control Messages (PC)

PCM 1 = Loop 1 ON, Loop 2 OFF
PCM 2 = Loop 1 OFF, Loop 2 ON
PCM 3 = Loop 1 ON, Loop 2 ON
PCM 4 = Loop 1 OFF, Loop 2 OFF

Continuous Control Messages (CC)

CC Number 80 - Loop 1
Value 0~64 = ON, 65~127 = OFF
CC Number 81 - Loop 2
Value 0~64 = ON, 65~127 = OFF

SETUP EXAMPLES

The Remotest Loopy2 can be set up in MONO or STEREO or a combination of either.

Set Up Example 1 – MONO Connections

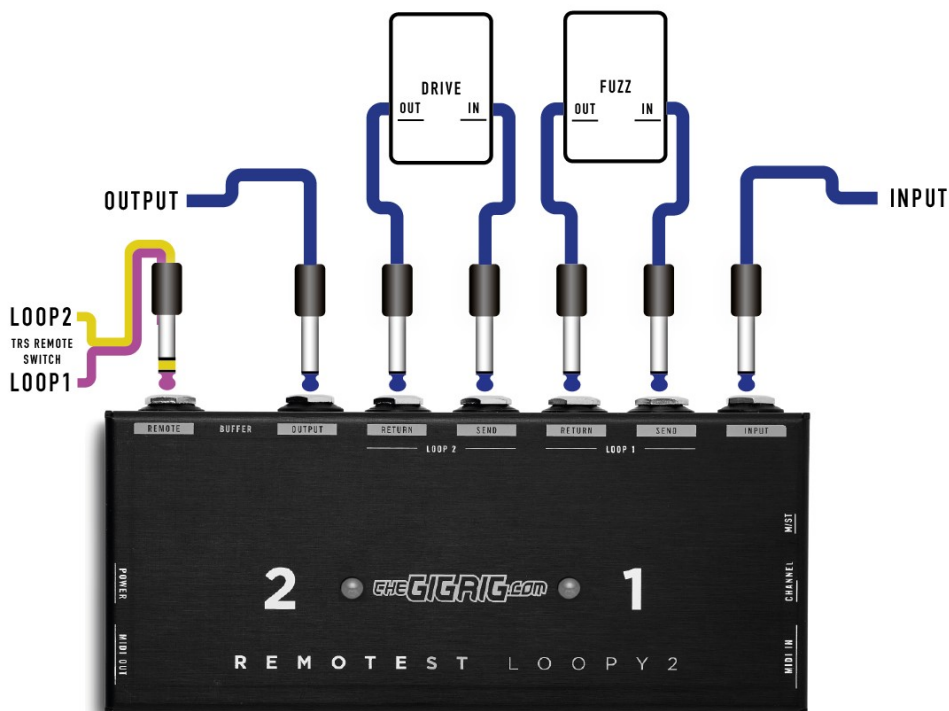

ST/M Switch setting for a standard MONO set-up is ST. The ST/M switch only applies when you are using a MONO input with TRS cables in the effect loops.

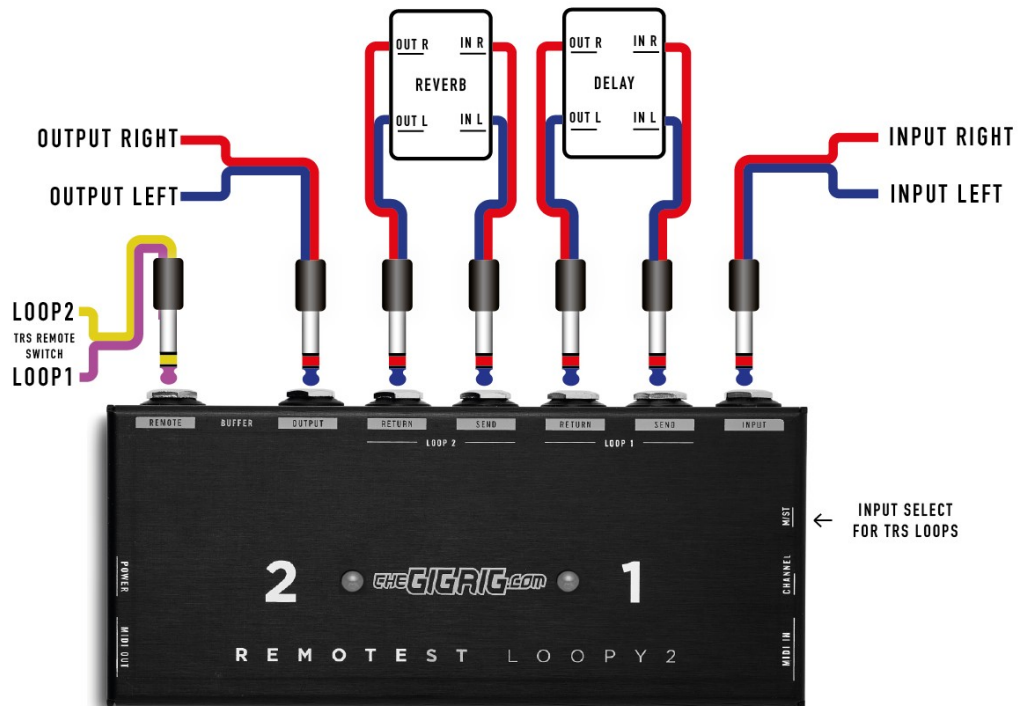

ST/M Switch setting for a standard STEREO set-up is ST.

Set Up Example 3 – MONO IN/STEREO OUT Connections

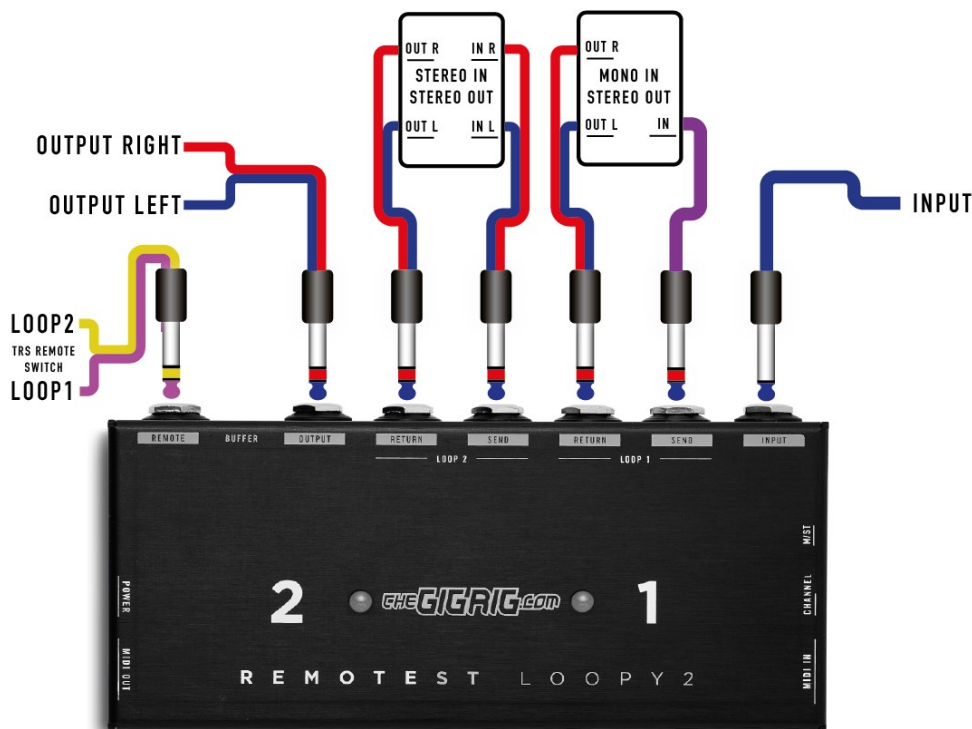

For a pedal that has a MONO input and a STEREO output, select M on the M/ST switch. In this setting the TIP is sent to both the TIP and RING on the loop sends.

As soon as you have a TRS cable in a loop send or return, it is important that all send and return connections are TRS. If not, you will find that the shield/ground of the mono cable will short the stereo side to ground giving you only a mono connection. The M/ST switch means you can choose if the MONO input goes to both TIP and RING, but it will need a connection that includes both TIP and RING to do this.

Set Up Example 4 – Mixing MONO and STEREO Effects

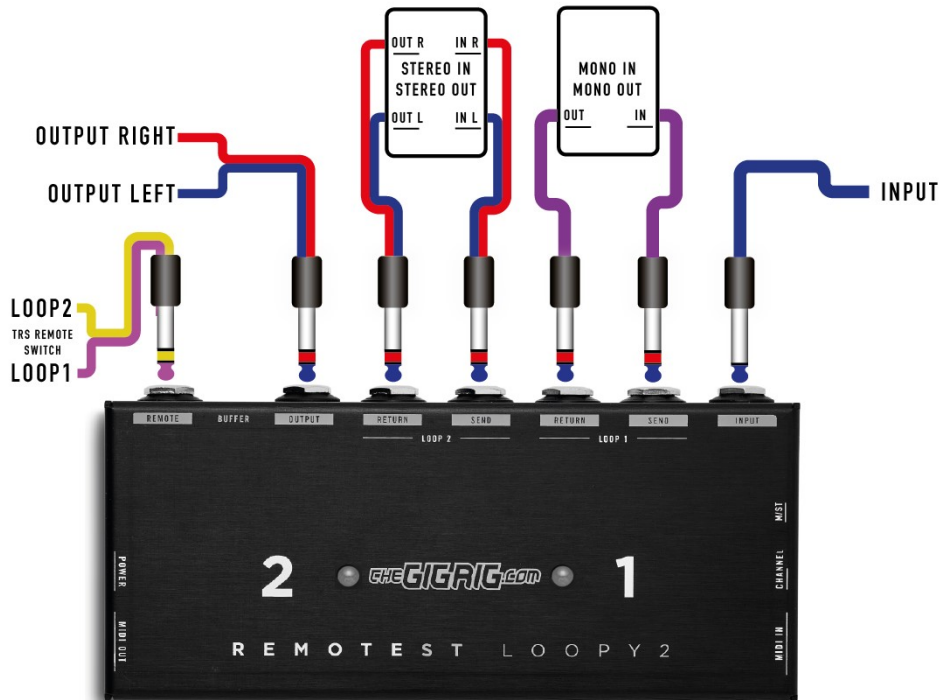

When mixing MONO and Stereo effects, you need to remember that as soon as you put a TRS in any of the send and returns, every send and return will need a TRS connection. Pay special attention to the cable on the LOOP RETURN. If you want to be able to switch between combinations of MONO and STEREO effects the output of the MONO effect needs to go both to the left and right return of the REMOTEST LOOPY2 Loops. The easiest way to achieve this is with a MONO to TRS/STEREO cable.



The signal section of the MONO cable (standard guitar cable) is connected to both the TIP and RING of the TRS connector. The standard TS connector sends the signal from the OUTPUT of your MONO effect. The TRS connector takes the MONO signal and sends it to both the LEFT and RIGHT channels of the EFFECTS LOOP RETURN.

FAQ's

Can I change the order of the loops?

No, the loops are in series, going from right to left, the Loop 1 signal will feed into loop 2 but only if both loops are selected.

Can I use it in my amp's FX loop?

Yes. The Remotest Loopy2 can be used pretty much anywhere in your signal path, from instrument to line level and beyond.

When would I use the buffer?

The stereo buffer is located after the effect's loops. This is so the output signal has a consistent impedance level regardless of what is in the loops. The loops themselves are passive and fed with whatever signal precedes them. With the Remotest Loopy2 at the end of the pedalboard the buffer will keep the impedance consistent. With it placed at the

start of your rig you have 2 passive loops that will work with anything including germanium fuzzes, then the option to buffer the signal after that.

Thank You

By buying this GigRig product you are supporting a small team of ridiculously talented engineers, tech advisers, production heroes, admin legends and their families. If you need anything please contact us through our support page at thegigrig.com/support and don't forget to check out our YouTube channel for more info.

Technical Specifications:

Buffer Input Impedance: 680K Ohm

Buffer Output Impedance: 100 Ohm

Current Draw: 220mA

Input Voltage. 9V DC 2.1mm centre negative

Input is reverse diode protected

Safety: The GigRig Remotest Loopy2 is designed for indoor use only - Don't get it wet

Warranty:

The GigRig warrants the product to be free from defects in material and workmanship for a period of 2 years from the original date of purchase. If the product fails within the warranty period, The GigRig will repair or, at our discretion, replace the product and cover the cost of return shipping to the original purchaser. This warranty covers defects in manufacturing discovered while using this product as recommended by The GigRig. This warranty does not cover loss or theft, nor does the coverage extend to damage caused by misuse, abuse, unauthorized modification, improper storage, lightning, or natural disasters. Damage caused by any of the above circumstances may result in a non-warranty repair fee

Legal:

In the case of malfunction, the purchaser's sole recourse shall be repair or replacement, as described in the preceding paragraphs. The GigRig will not be held liable to any party for damages that result from the failure of this product. Damages excluded include, but are not limited to, the following: lost profits, lost savings, damage to other equipment, and incidental or consequential damages arising from the use, or inability to use this product. In no event will The GigRig be liable for more than the amount of the purchase price, not to exceed the current retail price of the product. The GigRig disclaims any other warranties, express or implied. By using the product, the user accepts all terms herein.

Disposal:

Return the unit to The GigRig Ltd for disposal or use standard disposal for electrical equipment recommended in your country



UK
CA



Approved. Fully compliant with the RoHS√ standard.