

SGC



SGC DROP AXLE

LIFT KIT

**FITS EZGO TXT 01.5 and before,
GAS**

LIFT KIT INSTALLATION INSTRUCTIONS

EZ-GO 2001.5 & BEFORE TXT, GAS

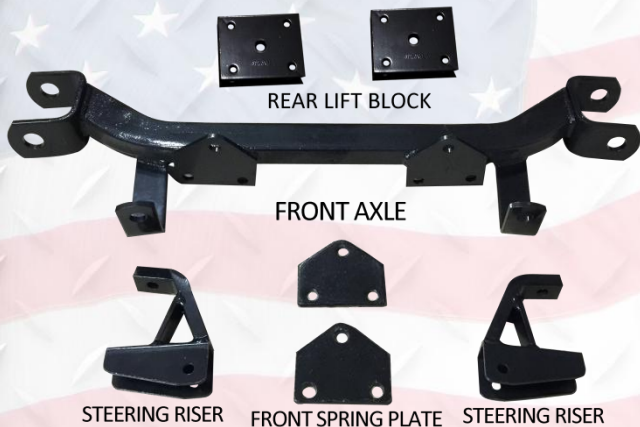

Hardware

HEX BOLT M10*50	2
HEX BOLT M10*30	2
NYLON NUT M10	4
HEX BOLT 3/8-16*3 1/2	8
NYLON NUT 3/8-16	8

Front Installation:

1. Jack up the front end of the car and remove the wheels and tires.
2. Remove the tie rod joints from the spindles. Remove the spindles from the front axle. Clean and lubricate these bolts for the re-installation of the spindles.
3. Remove the front axle from the leaf springs, clean and lubricate the bolts for the new axle installation.
4. Install the **FRONT AXLE** using the bolts from the old axle.
5. Mount the leaf springs to the new axle using the stock bolts and the new **FRONT SPRING PLATES**.
6. Re-install the spindles to the new axle. Install the new **STEERING RISER**. M10*30 bolt goes through the existing hole in the spindle and M10*50 bolt goes through the remaining hole in the extension. This bolt must be installed with the head towards the tire.
7. Attach the tie rod ends to the steering riser extension.
8. Securely tighten all bolts. Install new wheels and tires. Lower the jack and put the car on the ground. Set toe-in approx. 1/8" .

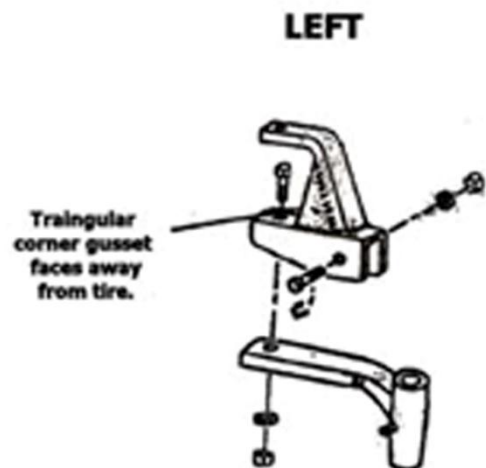
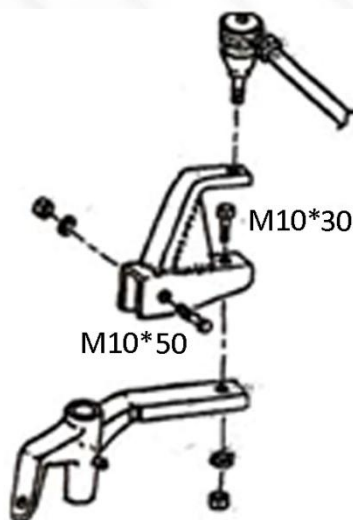

LIFT KIT INSTALLATION INSTRUCTIONS

EZ-GO 2001.5 & BEFORE TXT, GAS

Rear Installation:

1. Raise the rear of the car and support with jack stands as high as possible. Remove the tires and support the rear axle assembly with a floor jack.
2. Unbolt and move the shock out of the way, and save the hardware. Remove the springs and mark them so they are installed the same way.
3. Place the **rear lift block** on top of the axle using supplied bolts 3/8-16*3 1/2 and nuts. Place the rear leaf spring on top of the **rear lift block**.
4. Place the factory shock plate on top of the spring. Make sure the keeper pins are lined with the locator hole. Cut a notch in the rubber bushings so it will fit around the locator pin.
5. Install the cap and rubber bushing from the bottom up. Install the bolts from top of the shock plate through the shock mounts and cap assembly. Snug the bolts and install the assembly back into the cart mounting locations. After everything is in place, tighten all the nuts and bolts. Install the shocks and tighten until the bushings flatten to the size of the cup washer.

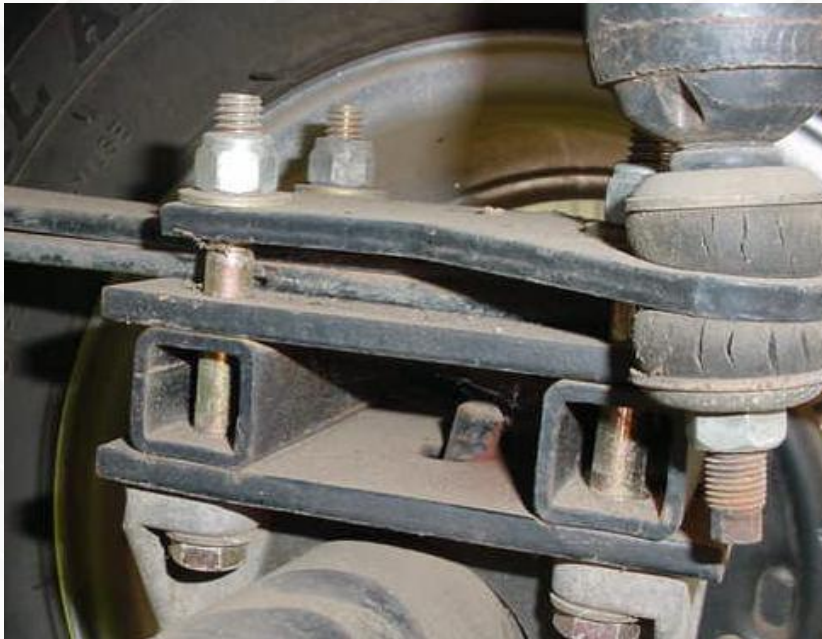

Side view



Top view



RETURN MERCHANDISE AUTHORIZATION

Dear Valued Customer,

Thank you for choosing Steeleng Golf Cart Accessories for your golf cart needs.

We apologize for the issues you are having with your purchase. We strive to offer the absolute best quality at the absolute best price.

To best serve you, we do need a little information to help process your return and/or exchange faster.

Please complete the following and include this entire form with your return.

Name

Shipped To Address

STATE

ZIP

Purchased with:

eBay

Direct Phone Order

This is for

EXCHANGE

REFUND

Please describe reason for return:-

Our Return Address:

Steeleng Golf Cart Accessories

3309 Laurens Road,

Greenville, SC 29607

Tele: 864-675-1103

For Office Use Only:

Received By: _____

Date _____

Refund Amount _____

Exchange Issued _____

**Steeleng Golf Cart Accessories reserves the right to charge a 15% restocking fee for all returned and/or exchanged items.