

### DHS Series — Direct Drive



DH-3504-SP3H6A

*The DHS Series features a unique Electro Magnetic Firing (EMF) system and is great for removing grease and oils from equipment and garage and workshop floors.*

#### PUMP

- External bypass system protects from heat build-up (AR pump models)
- Preset stainless-steel and brass unloader valve
- Forged brass manifold
- Thermal relief valve
- Low pressure detergent injector (Available as an option on DH-2503 models)

#### ENGINE

- Performance-proven engine with low-oil shutdown

#### FRAME

- Reinforced powder coated steel frame with center balanced lift
- 13-inch flat-free tires

#### COMPONENTS

- Top-fired powder coated heat exchanger
- No. 1 or No. 2 diesel or kerosene fired burner (Not approved for bio-fuel)

#### MISCELLANEOUS

- Temperature rise 150°F/66°C above ambient, maximum outlet temperature is 200°F

#### UNIT INCLUDES

- Quick connect nozzles – 0°, 15°, 25° and 40°
- 50-foot x 3/8-inch steel wire-braided high pressure hose
- Adjustable pressure insulated dual lance
- Professional-grade insulated trigger gun with safety lock-off

#### LIMITED WARRANTY

- 3 year engine

#### CERTIFICATION

- CSA Certified – US and Canada (Honda, Kohler and Vanguard engines)



# Portable Gasoline

## Hot Water – DHS Series – Direct Drive

MODEL NUMBER	PSI	GPM	DISPLACEMENT/ENGINE	PUMP	ENGINE FUEL TANK CAPACITY	BURNER FUEL TANK CAPACITY	BURNER FUEL CONSUMPTION	BTU PER HOUR	DIMENSIONS (LxWxH)	SHIP WT.	NET WT.
DH-2503-SP0H6M	2500	2.6	196cc Honda GX200 OHV	Mi-T-M	0.83 gallon	4.0 gallons	1.53 gph	210,000	43x29.5x36.5in.	411 lb.	295 lb.
DH-2503-SP0K6M	2500	2.6	208cc Kohler CH270 OHV	Mi-T-M	0.78 gallon	4.0 gallons	1.53 gph	210,000	43x29.5x36.5in.	411 lb.	295 lb.
DH-2503-SP0M6M	2500	2.6	212cc Mi-T-M OHV	Mi-T-M	0.95 gallon	4.0 gallons	1.53 gph	210,000	43x29.5x36.5in.	411 lb.	295 lb.
DH-3003-SP3H6A	3000	2.9	270cc Honda GX270 OHV <sup>+</sup>	AR	1.40 gallons	5.5 gallons	1.84 gph	253,000	43x30x41in.	530 lb.	407 lb.
DH-3504-SP3H6A	3500	3.3	389cc Honda GX390 OHV <sup>+</sup>	AR	1.61 gallons	5.5 gallons	2.14 gph	294,000	43x30x41in.	551 lb.	428 lb.
DH-3504-SP3K6A	3500	3.3	429cc Kohler CH440 OHV	AR	1.85 gallons	5.5 gallons	2.14 gph	294,000	43x30x41in.	551 lb.	428 lb.
DH-3504-SP3M6A	3500	3.3	420cc Mi-T-M OHV	AR	1.72 gallons	5.5 gallons	2.14 gph	294,000	43x30x41in.	551 lb.	428 lb.
DH-3504-SP3V6A	3500	3.3	408cc Vanguard OHV	AR	1.51 gallons	5.5 gallons	2.14 gph	294,000	43x30x41in.	551 lb.	428 lb.

<sup>+</sup>49 state engine. Not for sale in California.

### ACCESSORIES:

PART NUMBER	DESCRIPTION	FITS MODELS
50-0161	High pressure detergent injector – High pressure water mixes with detergent to clean even the heaviest build-up	All models
850-0433	50-foot x 3/8-inch hose – For when you need extra hose for added mobility	3500-PSI models
851-0262	50-foot x 3/8-inch hose – For when you need extra hose for added mobility	2500 to 3000-PSI models

### OPTIONS:

PART NUMBER	DESCRIPTION	FITS MODELS
HX-0234	Low pressure detergent injector – Allows the user to apply the recommended detergents	2500-PSI models
HX-0274	Rain cap – Protects boiler from moisture build-up when unit is left outside	3000 to 3500-PSI models
HX-0236	Hour meter – Displays the number of hours unit has been in operation	2500-PSI models
HX-0279*	Hour meter – Displays the number of hours unit has been in operation	3000 to 3500-PSI models
HX-0233	Adjustable thermostat – Operator is able to adjust outlet water temperature between 98°-248°F	2500-PSI models
HX-0280*	Adjustable thermostat – Operator is able to adjust outlet water temperature between 98°-248°F	3000 to 3500-PSI models
HX-0281	Hour meter and adjustable thermostat – Displays the number of hours unit has been in operation; operator is able to adjust outlet water temperature between 98°-248°F	3000 to 3500-PSI models
HX-0286	Electric start – battery not included – For easy starting	DH-3504-SP3H6A
HX-0300	Skid feet – For stationary applications	3000 to 3500-PSI models

\*You cannot order HX-0279 and HX-0280 together, you will need to order HX-0281 instead.

HX-0279 and HX-0280 can be ordered separately.

## EMF SYSTEM

1. Engine sheave maintains proper alignment of pump shaft key.
2. Tension sheave creates proper belt tension so fuel pump discharges fuel when needed.
3. Non-corrosive flexible drive coupler protects EMF system.
4. Fuel pump.
5. Stator coil/magnets provide solenoid control voltage.
6. Fan provides air for proper combustion and clean exhaust.
7. Ignition coil provides voltage to electrodes for proper spark voltage, allowing accurate ignition of fuel.

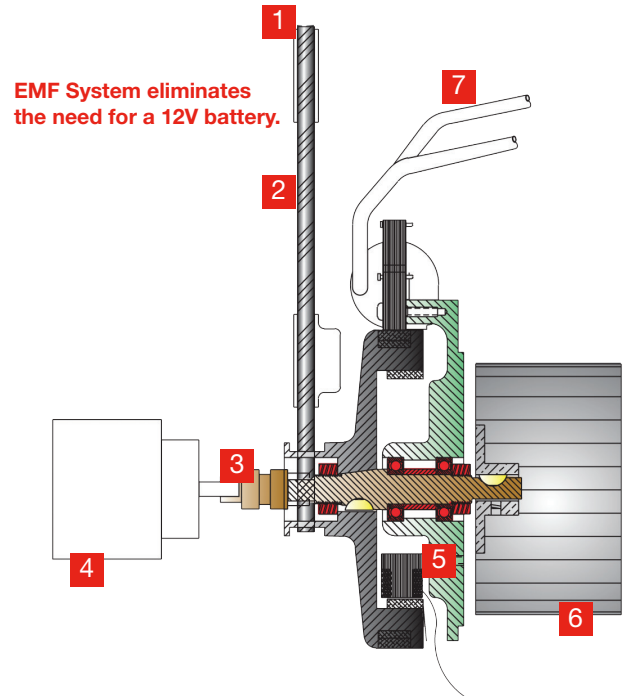

**WARNING:** Cancer and Reproductive Harm - [www.P65Warnings.ca.gov](http://www.P65Warnings.ca.gov).