

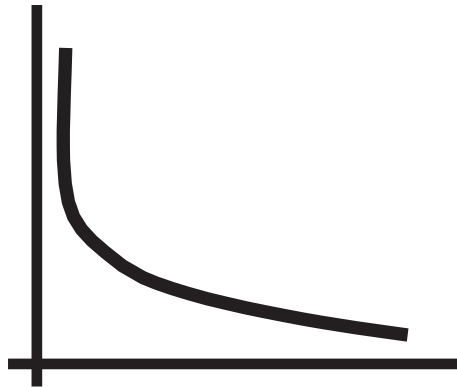

F-PRO

**Directional Multifunction & UV / OV Protection Relay
Model 235**



User Manual

Version 2.6 Rev 0

Preface

Information in this document is subject to change without notice.

© 2019 Easun Reyrolle Ltd. All rights reserved. Reproduction in any manner what so ever without the written permission of Easun Reyrolle Ltd. is strictly forbidden. This manual is part of a complete set of product documentation that includes detailed drawings and operation. Users should evaluate the information in the context of the complete set of product documentation and their particular applications. ERL assumes no liability for any incidental, indirect or consequential damages arising from the use of this documentation.

While all information presented is believed to be reliable and in accordance with accepted engineering practices, ERL makes no warranties as to the completeness of the information.

All trademarks used in association with L-PRO, T-PRO, F-PRO, B-PRO, S-PRO, TESLA, iTMU, TESLA Control Panel, Relay Control Panel, RecordGraph, RecordBase and ProLogic are trademarks of ERLPhase Power Technologies Ltd.

Windows[®] is a registered trademark of the Microsoft Corporation. Modbus[®] is a registered trademark of Modicon.

Contact Information

Easun Reyrolle Ltd.,

Website: www.easunreyrolle.com

Email: hosur@easunreyrolle.com

Technical Support

Email: techsupport@easunreyrolle.com

Tel: +91-4344-401600/01/02

ERLPhase Power Technologies Ltd.,

Website: www.erlphase.com

Email: info@erlphase.com

Technical Support

Email: support@erlphase.com

Tel: 1-204-477-0591

Using This Guide

This User Manual describes the installation and operation of the F-PRO Multifunction Protection Relay. It is intended to support the first time user and clarify the details of the equipment.

The manual uses a number of conventions to denote special information:



Example	Describes
<i>Start>Settings>Control Panel</i>	Choose the Control Panel submenu in the Set - tings submenu on the Start menu.
Right-click	Click the right mouse button.
<i>Recordings</i>	Menu items and tabs are shown in italics.
Service	User input or keystrokes are shown in bold.
Text boxes similar to this one	Relate important notes and information.
..	Indicates more screens.
	Indicates further drop-down menu, click to display list.
	Indicates a warning.

Table of Contents

Preface	i
Contact Information	i
Using this Guide	ii
Table of Contents	iii
Acronyms	v
Version Compatibility	vi
PC System Requirements and Software Installation	vii
1. Overview	
1.1 Introduction	1-1
1.2 Front View	1-3
1.3 Rear View	1-4
1.4 Model Options/Ordering Template.....	1-5
2. Setup and Communications	
2.1 Introduction	2-1
2.2 Power Supply	2-1
2.3 Time Sources	2-2
2.4 Communicating with the Relay IED	2-4
2.5 USB Link	2-4
2.6 Network Link	2-7
2.7 Firmware Update	2-8
2.8 Accessing the Relay's SCADA Services	2-9
2.9 Communication Port Details.....	2-10
3. Using the IED (Getting Started)	
3.1 Introduction	3-1
3.2 Start-up Sequence	3-1
3.3 Interfacing with the Relay	3-1
3.4 Front Panel Display	3-2
3.5 Relay Control Panel	3-18

4. Protection Functions, Applications and Specifications	
4.1 Protection and Recording functions	4-1
4.2 Recording Functions	4-30
Logging Functions	4-33
5. Data Communications	
5.1 Introduction	5-1
5.2 SCADA Protocol	5-1
5.3 IEC 61850 Communication	5-3
6. Settings and Analysis Software	
6.1 Introduction	6-1
6.2 Offliner Setting Software	6-1
6.3 Offliner Features	6-2
6.4 Offliner Keyboard Shortcuts	6-5
6.5 Handling Backward Compatibility	6-6
6.6 Main Branches from the Tree View	6-8
6.7 Settings from a Record	6-20
6.8 Record Graph Software	6-21
6.9 ERL 61850 IED Configurator	6-22
7. Acceptance/ Peripheral Test Guide	
7.1 Introduction	7-1
7.2 Acceptance Testing	7-1
8. Installation	
8.1 Introduction	8-1
8.2 Physical Mounting	8-1
8.3 AC and DC Wiring	8-1
8.4 Communication Wiring	8-1
Appendix A IED Specifications	A-1
Appendix B IED Settings and Ranges	B-1
Appendix C Hardware Description	C-1
Appendix D Event Messages	D-1
Appendix E Modbus RTU Communication Protocol	E-1

Appendix F IEC 103 Device Profile	F-1
Appendix G DNP3.0 Device Profile.....	G-1
Appendix H Mechanical Drawings	H-1
Appendix I AC Schematic Drawings	I-1
Appendix J DC Schematic Drawing	J-1
Appendix K Function Logic Diagram	K-1
Appendix L Connection Diagram.....	L-1
Appendix M F-PRO Setting Example.....	M-1
M.1 Failure Modes.....	M-2
Appendix N IEC 61850 Data Mapping Specifications.....	N-1
N.1 Protocol Implementation Conformance Statement	N-1
N.2 Model Implementation Conformance Statement	N-9
N.3 Data Mapping Specifications	N-29

Acronyms

ASG	- Active Setting Group
CT	- Current Transformer
DCE	- Data Communication Equipment
GPS	- Global Positioning System
GUI	- Graphical User Interface
HMI	- Human Machine Interface
ICD	- file extension (.ICD) for IED Capability Description
IEC	- International Electro-technical Commission
IED	- Intelligent Electronic Device
IP	- Internet Protocol (IP) address
IRIG-B	- Inter-Range Instrumentation Group time codes
LED	- Light-emitting Diode
LCD	- Liquid Crystal Display
LHS	- Left Hand Side
RHS	- Right Hand Side
RTU	- Remote Terminal Unit
SCADA	- Supervisory Control And Data Acquisition
DNP	- Distributed Network Protocol
SG	- Setting Group
TCP	- Transmission Control Protocol
UI	- User Interface
VI	- Virtual Input

Version compatibility

This chart indicates the versions of Offliner Settings, Relay Control Panel, RecordGraph and this User Manual was created using the following software and firmware versions.

Record Graph and Offliner Settings are backward compatible with all earlier versions of records and setting files. Use Record Graph to view records produced by any version of F-PRO firmware and Offliner Settings can create and edit older setting file versions.

F-PRO Firmware / Software Compatibility Guide					
F-PRO Firmware	Setting Version	Compatible Offliner Settings	RCP Version	RG Version	ICD File Version
v2.6	5	v2.6	v2.9	v5.4a	v3.1

Please contact ERL Technical support for complete Revision History.

PC System Requirements and Software Installation

Hardware

The minimum hardware requirements are:

- 1 GHz processor
- 2 GB RAM
- 20 GB available hard disk space
- USB port and Ethernet port (RJ45)
- Serial communication port

Operating System

One of following Operating System must be installed and functional prior to installing the applications:

- Microsoft Windows 7
- Microsoft Windows 10

ERL & ERLPhase Softwares requires a minimum of Windows 7 OS (RCP/Offliner/RG/IED Configurator will not work on earlier versions of Windows).

Software Installation

All required software for user interface, setting and record analysis are available directly from the ERL website <http://www.easunreyrolle.com/product.php?id=60T>. The following relevant software and documentation is available:

- F-PRO Offliner : Software
- Relay Control Panel : Software
- USB Gadget Driver : Software
- Record Graph : Software
- ERL 61850 Configurator Tool : Software
- Relay Control Panel User Manual : Manual in PDF format
- Relay User manual : Manual in PDF format

To Install Software on the Computer

To install the software on the computer, click the desired item on the screen. The installation program launches automatically. Installation may take a few minutes to start.

USB Gadget driver also to be installed.

Anti-virus/Anti-spyware Software

If an antivirus/anti-spyware software on user local system identifies any of the ERL & ERLPhase applications as a “potential threat”, it will be necessary to configure user antivirus/anti-software to classify it as “safe” for its proper operation. Please refer the appropriate antivirus / anti-spyware software documentation to determine the relevant procedure.

1 Overview

1.1 Introduction

The F-PRO is a microprocessor-based relay providing comprehensive Directional Overcurrent, Earth Fault Protection, UnderVoltage/OverVoltage, Auto Reclosing, Circuit Breaker Failure, Broken Conductor, Thermal Overload, Negative Sequence Overcurrent, Inrush Restraint, Trip Circuit Supervision, Metering, Breaker Monitoring and Recording Functions suitable for transmission, sub transmission and distribution applications.

ERL GUI software has two working modes - online and offline. Relay Control Panel is the online tool, which enables the user to:

- Change, review & retrieve relay settings
- View event, fault and metering information
- Store records
- Trigger and retrieve records.

F-PRO Offliner is the offline tool which enables the user to:

- Create and review relay settings

RecordGraph will enable the user to:

- Analyze fault waveforms (Disturbance Records)

In addition to the protection functions F-PRO provides fault recording (32 samples / cycle) for analysis of the power system after a disturbance has occurred. The triggers for fault recording are established by programming the output matrix. The Output Matrix allows any internal relay function, external input or GOOSE messaging input to initiate record.

The primary protection provided is Directional and Non-Directional overcurrent. A library for these overcurrent functions provides commonly used IEEE and IEC inverse curves. Since the curves are equation-driven, the user can choose to enter equation parameters directly to create other overcurrent curve shapes as needed.

To provide a complete package of protection and control, F-PRO provides other functions such as:

- Breaker Failure Protection (50BF)
- Multi-shot Auto Recloser (79)
- Under Voltage / Over Voltage (27 / 59)
- CT Fail Supervision (60CTS)
- VT Fail Supervision (60VTS)
- 20 ProLogic statements
- 30 Virtual Inputs
- 4 Setting Groups

Relay Control Panel (RCP) is the Windows graphical user interface software tool provided with ERL relays. RCP is used to:

- Retrieve and manage records, event logs and fault logs
- Manage settings
- Display real-time metering values
- Export records to COMTRADE format

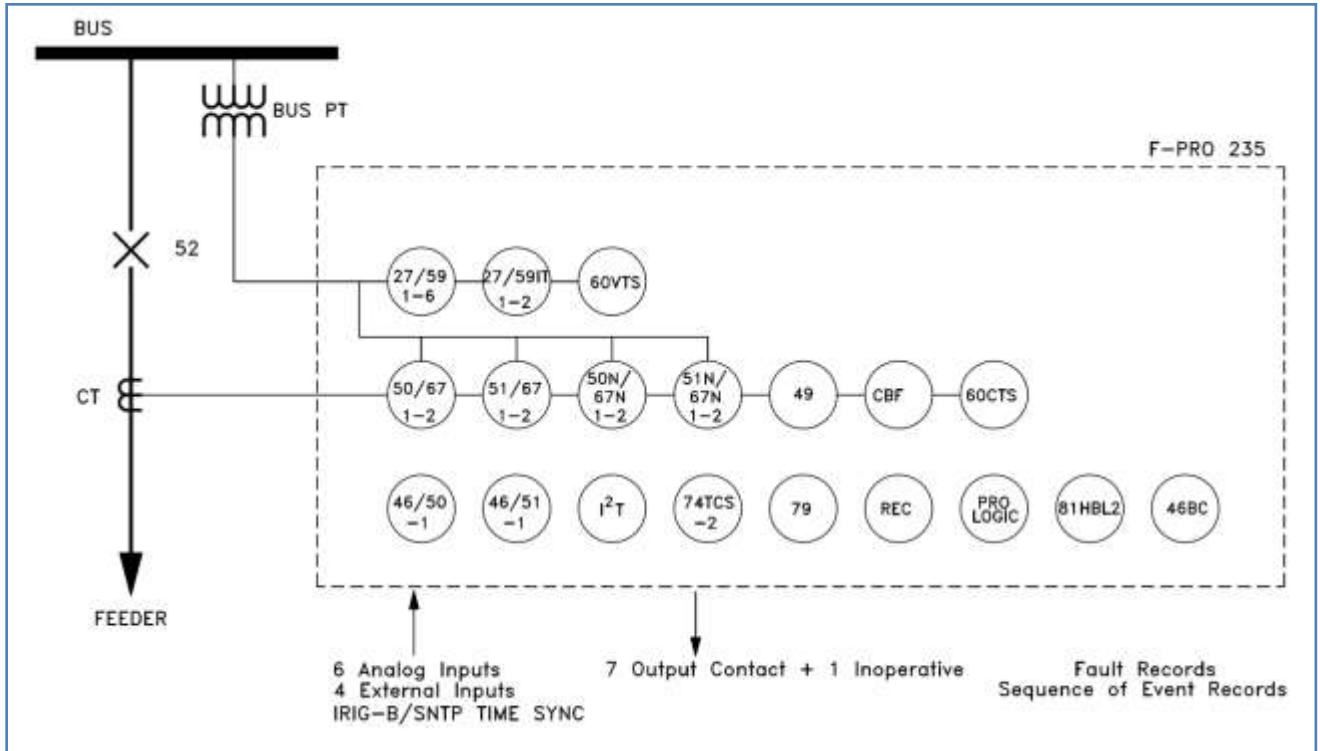

Figure 1.1: F-PRO Relay Function Line Diagram

1.2 Front View

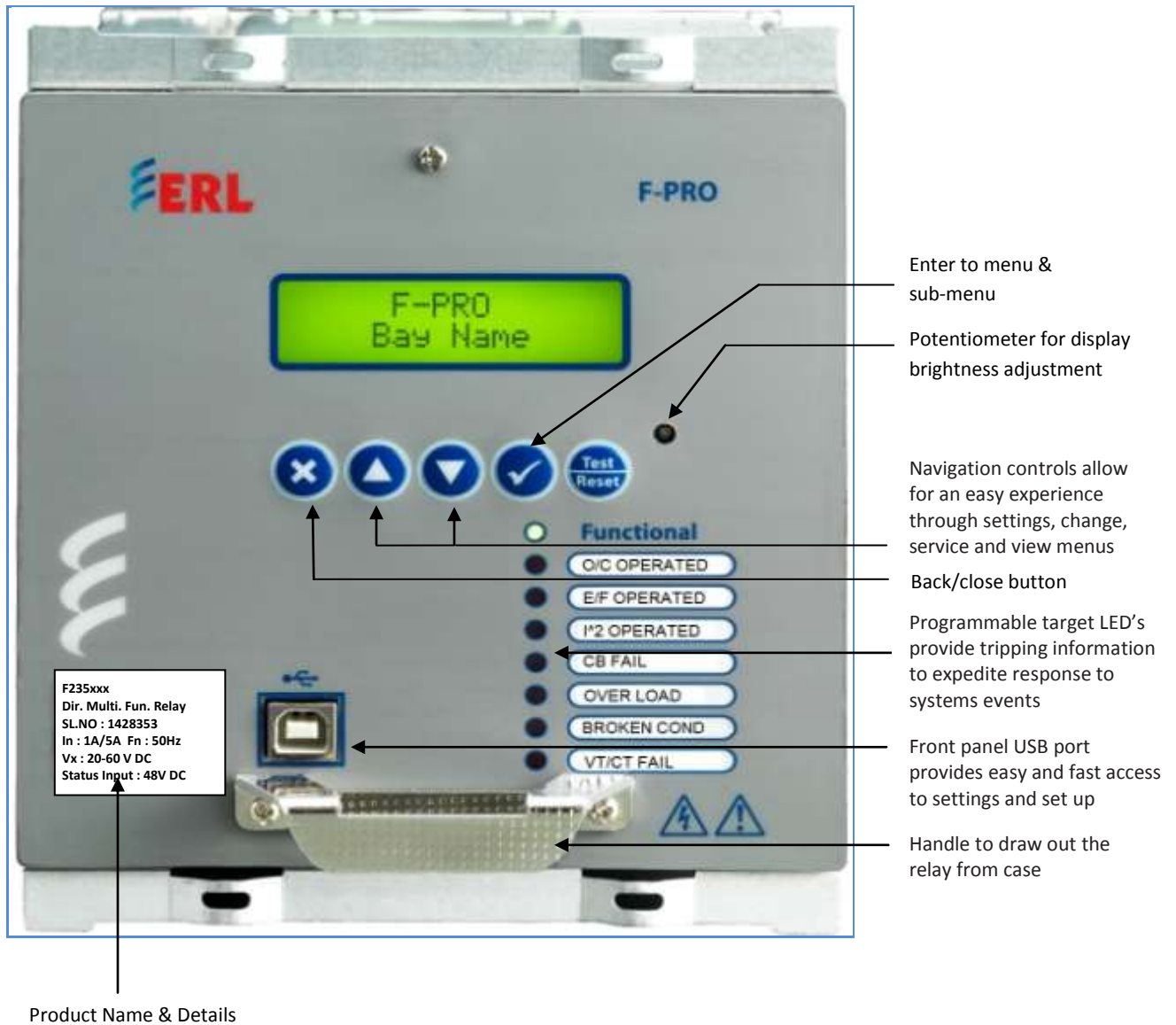

Figure 1.2: F-PRO Front View

1.3 Rear View

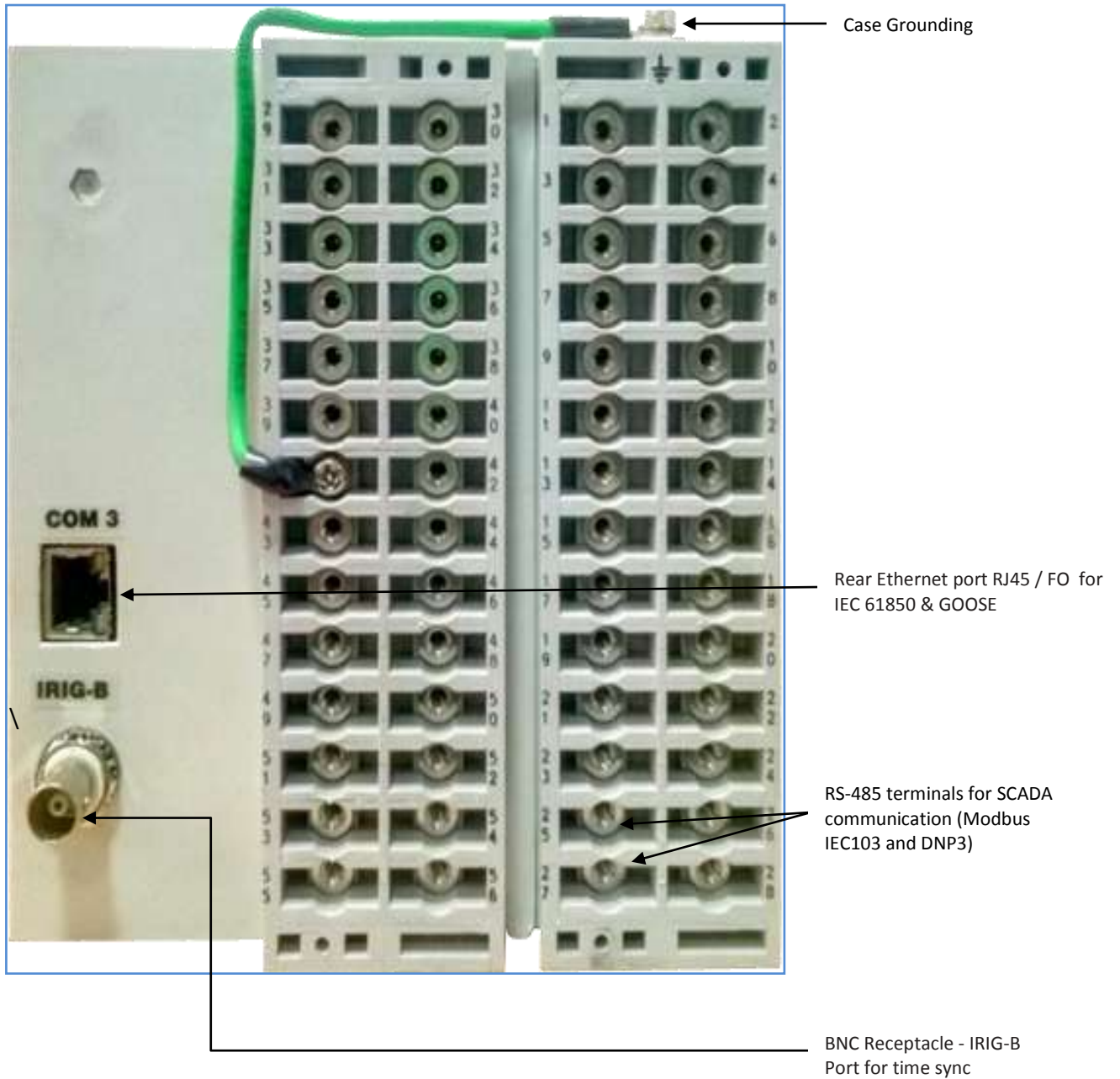

Figure 1.3: F-PRO Rear View

<p>AC Current / Voltage Inputs</p>	<p>F-PRO is provided with terminal blocks for up to 3 AC currents and 3 AC Voltage Inputs. 1A and 5A terminals are provided with isolated neutral and CT Secondary is Site Selectable.</p> <p>To refer the complete schematic circuits; see “AC Schematic Drawing” in Appendix-I & “DC Schematic Drawing” in Appendix-J</p>
<p>External Inputs</p>	<p>F-PRO relay has 4 external inputs with a factory selectable voltage level. External DC voltages of either 24 volts, 48 volts, 110 volts, 220 volts nominal are available depending on the ordering code.</p>
<p>Relay Inoperative Alarm Output</p>	<p>If the relay becomes inoperative, then the Relay Inoperative Alarm output contact closes. Output Contact 1 and/or 6 may be configured as Relay Inoperative Alarm Contacts. During the relay inoperative period, all tripping functions are blocked.</p>
<p>Output Relay Contacts</p>	<p>The F-PRO relay has 8 output relay contacts. Each contact is programmable and has breaker tripping capability. All output contacts are isolated from each other. All the contacts are provided with settable dropout timers (0-1 sec) - applicable for self reset.</p> <p>If function reset time & the output contact reset time both are set in the IED; then, the higher value will be taken for relay drop out. Example: 51N function is chosen with reset DTL delay 0.5 sec and the output contact dropout time is 0.8 sec, then 0.8 sec will be the dropout time of the output contact.</p>

1.4 Model Options/Ordering Template

- The relay is available in E6 size and flush mount type along with standard IRIG-B / SNTP time sync. For details see “Mechanical Drawings” in [Appendix H](#).
- The relay is available with an optional Ethernet port (RJ45/FO).
- The external inputs are 24, 48, 110, 220 Vdc rated. The Auxiliary supply is 20-60 Vdc or 80-300 Vdc rated.
- All of the above options must be specified at the time of ordering.

F-PRO Feeder Protection Relay

Ordering Template

In order to specify and order an ERL relay properly configured for the application, a part number must be constructed as indicated below:

F-PRO aaa b c d

aaa - Model: _____

- **215:** (50, 51, 50N, 51N, 50G, 51G, 46/50, 46/51, 49, 50BF, 46BC, 81HBL2, I^t-CB, 79) - **4CT**
- **216:** (50, 51, 50N, 51N, 50G, 51G, 64/50SEF, 64/51SEF, 46/50, 46/51, 49, 50BF, 46BC, 79, 81HBL2, I^t-CB) - **5CT**
- **235:** (27/59DT, 27/59IT, 50/67, 51/67, 50N/67N, 51N/67N, 27/59DT, 27/59IT, 46/50, 46/51, 49, 50BF, 46BC, 79, 60CTS, 60VTS, 81HBL2, I^t-CB) - **3CT + 3VT**
- **295:** (27/59DT, 27/59IT, 24DT, 24IT, 47DT, 47IT, 59NDT, 59NIT, 59GDT, 59GIT, 81U/O, 81R, 25/27/59, 64/50/67SEF, 64/51/67SEF, 60VTS, THD) - **SVT+1CT**
- **297:** (27/59DT, 27/59IT, 24DT, 24IT, 47DT, 47IT, 59NDT, 59NIT, 37, 50/67, 51/67, 50N/67N, 51N/67N, 50G/67G, 51G/67G, 46/50, 46/51, 64/50/67SEF, 64/51/67SEF, 49, CBF, 46BC, 81HBL2, 81U/O, 81R, 32, 60VTS, 60CTS, I^t-CB, THD, 79) - **3VT + 5CT**
- **298:** (27/59DT, 27/59IT, 24DT, 24IT, 47DT, 47IT, 59NDT, 59NIT, 37, 50/67, 51/67, 50N/67N, 51N/67N, 46/50, 46/51, 64/50/67SEF, 64/51/67SEF, 49, CBF, 46BC, 81HBL2, 81U/O, 81R, 32, 60VTS, 60CTS, I^t-CB, THD, 25/27/59, 79) - **4VT + 4CT**

b – Auxiliary Supply & External Input rating: _____

- **1:** Auxiliary supply - 20 to 60 Vdc External Input - 24 Vdc
- **2:** Auxiliary supply - 20 to 60 Vdc External Input - 48 Vdc
- **3:** Auxiliary supply - 80 to 300 Vdc External Input - 110 Vdc
- **4:** Auxiliary supply - 80 to 300 Vdc External Input - 220 Vdc

c – Enclosure, Number of Inputs, Outputs & LEDs: _____

- **A:** E6 case, 4 External Inputs, 8 Relay outputs & 8 LED's **
- **B:** E8 case, 14 External Inputs, 14 Relay outputs & 14 LED's *

d – Communication Ports: _____

- **1:** Redundant Ethernet Port (100BASE-T, RJ45, PRP) *
- **2:** Redundant Ethernet Port (100BASE-FX, ST, PRP) *
- **3:** One Ethernet Port (100BASE-T, RJ45)
- **4:** One Ethernet Port (100BASE-FX, ST)

* Applicable only for F-PRO297 & 298 Models, ** Applicable only for F-PRO215, 216, 235 & 295 Models

Example:

Ordering Code Example	F-PRO	215	3	A	3
Model - 50, 51, 50N, 51N, 50G, 51G, 46/50, 46/51, 49, 50BF, 46BC, 81HBL2, I ^t -CB, 79					
Auxiliary supply - 80 to 300 Vdc External Input - 110 Vdc					
Enclosure - E6 case, Number of Inputs, Outputs & LEDs - 4 External Inputs, 8 Relay outputs, 8 LED's					
Communication Ports - One Ethernet Port (100BASE-T,RJ45)					

Standard Functions & Features:

- 1A (or) 5A CT Secondary input is site selectable.
- Disturbance Recorder, Fault Recorder, Metering, ProLogic, Trip Circuit Supervision.
- Front USB port and rear serial RS485 port & Horizontal Flush panel mounting chassis.
- Modbus (or) IEC103 (or) DNP3.0 are supported over RS485 port and DNP3.0 & IEC 61850 (or) PRP are supported over Ethernet.
- IIRIG-B (or) SNTP for Time sync.

The specifications and product information contained in this document are subject to change without notice. In case of inconsistencies between documents, the version at www.esunrelyrolle.com will be considered correct. (100004R04)



Figure 1.4: F-PRO Ordering Options

2 Setup and Communications

2.1 Introduction

This chapter discusses setting up and communicating with the relay including the following:

- Power supply
- Simple Network Time Protocol (SNTP) & Inter-Range Instrumentation Group time codes (IRIG-B) for time input
- Communicating with the relay using a network link and a direct serial link
- Using Relay Control Panel to access the relay's user interface
- Accessing the relay's Supervisory Control and Data Acquisition (SCADA) service

2.2 Power Supply

A wide range power supply is standard. The relay power supply is provided with nominal operating ranges of:

- 20 to 60Vdc
- 80 to 300Vdc / 80 to 240 Vac, 50/60 Hz

To protect against a possible short circuit in the supply use an inline fuse or circuit breaker with a 5A rating. Ensure that the chassis is grounded for proper operation and safety.

There are no power switches on the relay. When the power supply is connected, the relay starts its initialization process and takes about 100 seconds to complete the boot and glowing the green LED for relay functional.

Case Grounding

WARNING!

Ground the relay to station ground using the case-grounding terminal at the back of the relay, for details see [Figure 1.3: F-PRO Rear View on page 1-4](#).

2.3 Time Sources

The F-PRO relay supports the use of modulated or unmodulated IRIG-B time signals (external), primary/secondary SNTP network based time synchronization (external) and manually configurable system time based on a free running internal oscillator. The internal free running oscillator is always present on the F-PRO and in the absence of any external time source, will become the default mode of time synchronization.

IRIG –B SYNC

An externally applied IRIG-B time source will have the highest order of precedence, and will typically offer the highest available time accuracy, when derived from an external GPS satellite source. The F-PRO will also process derived IRIG-B style signals generated from alternate time sources, using time quality information to differentiate. The LED output selection on the front panel is available for ongoing presence of a valid IRIG-B time source indication and is evident in data records.

The relay is equipped to handle modulated or un-modulated GPS satellite time IRIG-B signals. The IRIG-B time signal is connected to the BNC connection on the back of the relay. Setting is required to differentiate between modulated or un-modulated signal. This has to be manually changed by the user as per the input provided.

When the relay is drawn out from its case, jumpers are accessible behind the IRIG-B connect. If the J5 and J6 jumpers are positioned to short pins 1 and 2, then the IRIG-B port is configured to accept a modulated signal. If the J5 and J6 jumpers are positioned to short pins 2 and 3, then the IRIG-B port is configured to accept an un-modulated signal.

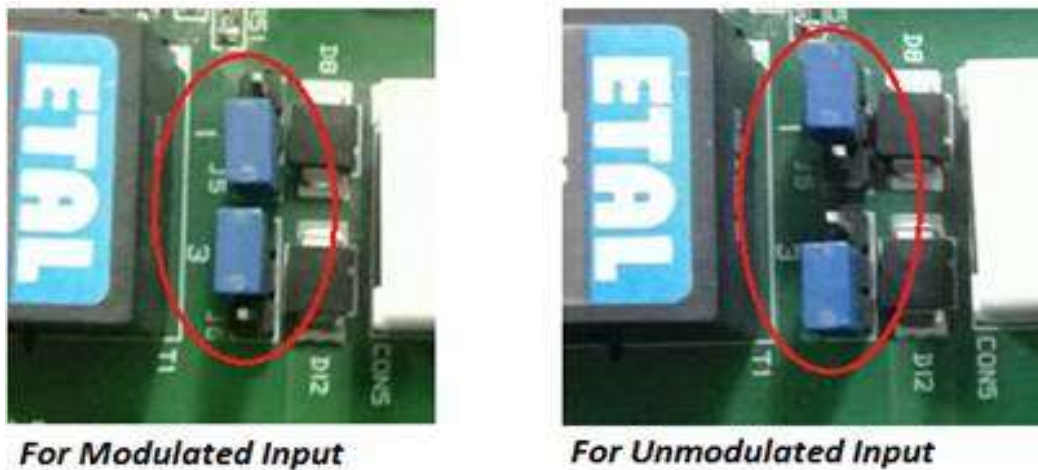

Figure 2.1: IRIG-B port for modulated and un-modulated input

If the IRIG-B signal contains year information, enable the IEEE 1344 extension on the *Utilities > Time* screen in Relay Control Panel. If the IRIG-B signal does not contain the year extension, this setting should be disabled.

SNTP SYNC

An SNTP time source has a lower order of precedence from a valid IRIG-B source. SNTP operation (primary and secondary) requires network access and the selection and configuration of suitable SNTP network sources. The SNTP time may be configured for re-synchronization cycles ranging from 15 minutes to 36 hours, adjusting the F-PRO system time to an accuracy of +/- 5 milliseconds in ideal network conditions. The LED output selection on the front panel is available for ongoing presence of a SNTP time source indication and is evident in data records.

The RCP time screen provides means to enable SNTP time source, set the poll interval, set the timeout interval and set the server IP addresses.

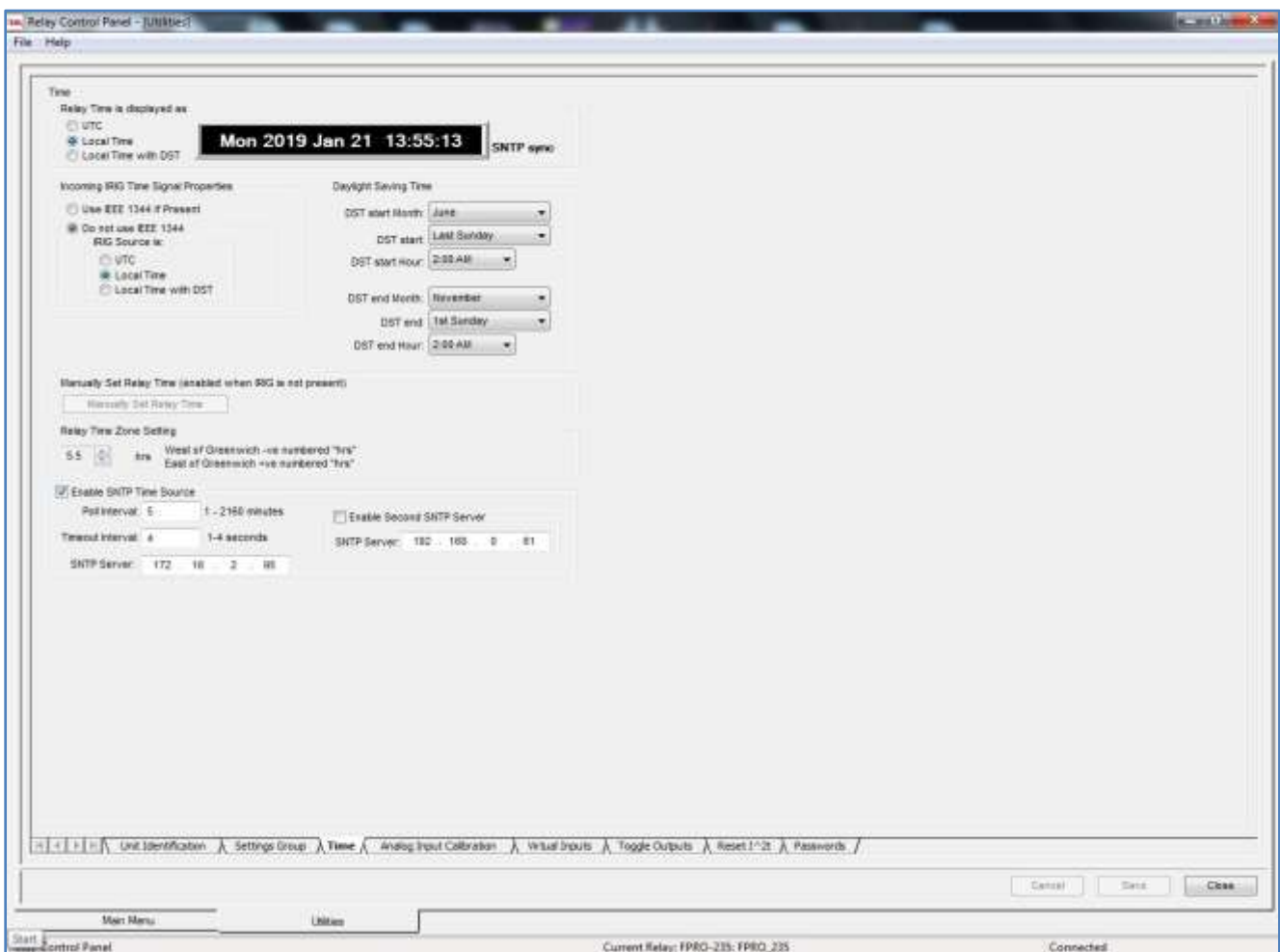

Figure 2.2: SNTP sync settings in RCP

If either a valid IRIG-B or SNTP source is present, then the relay will use the RTC run from the internal clock as the time source. The RTC is the lowest priority time source.

The IED comes equipped with an internal free-running oscillator used to generate a 1 PPS time signal in the absence of any alternate available time source. Use of this oscillator as the primary IED time source requires manual time configuration, with the general accuracy subject to user input parameters, and is recommended primarily for stand-alone, unsynchronized applications. The internal oscillator carries a lifetime accuracy (including temperature effects and aging) of +/-50 ppm.

2.4 Communicating with the F-PRO Relay

Connect to the Relay to its user interface and supervisory control and data acquisition (SCADA) services by:

- Front USB 2.0 interface (user interface and maintenance)
- 1 Rear Ethernet network link (user interface and SCADA)
- Rear panel serial link (RS485 serial link to SCADA only)

The relay has a front panel USB port (COM 1) and 1 Rear Ethernet Port (Copper / FO COM 3) for user interface and SCADA, 1 rear RS485 Port (COM 2) to provide direct access to SCADA services.

The relay's user interface is accessed through the Relay Control Panel.

2.5 USB Link

The PC must be appropriately configured for USB communication.

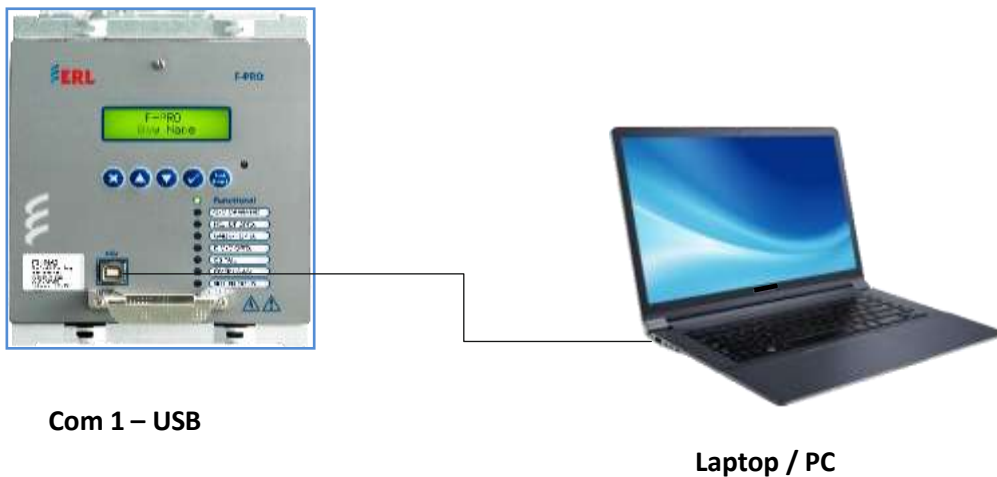

Figure 2.3: USB Link

USB Driver Installation

To create a USB link between the relay and the computer, connect the PC to the front USB port of the F-PRO. The Gadget Driver needs to be installed in computer as follows:

Gadget Driver can be downloaded from ERL website.

<http://www.easunreynolle.com/product.php?id=60>

Then go the Device Manager to check the port detect.

Start > Control Panel> Device Manager > Other devices

In this path a small icon with the name of Gadget Serial v2.4 will be found (If user removed USB cable, this icon will be removed from that path)

Next to that Right click on the Gadget Serial v2.4 icon and select "update Driver software".

"Update Driver Software - Gadget Serial v2.4" Window will appear.

In that select "Browse my computer for driver software".

Now Browse the Gadget driver folder the path where it was saved.

Example; D:\Gadget_driver\win7 (for Windows 7)

And click the next button. Now the Driver Installation will be started, after the Installation done click close.

Now check ports in Device Manager

Start > Control Panel > Device Manager > Ports (COM & LPT)

Can find "F-PRO2000 Series Relay" port, note COM port number which is installed Ex: COM 6.

Now Open the Relay Control panel

Start > All Programs > ERLPhase > Relay Control Panel

In that Click the Add new Button. Add New Relay Window will open. In that select the "Add New Modem/Serial Link" Button.

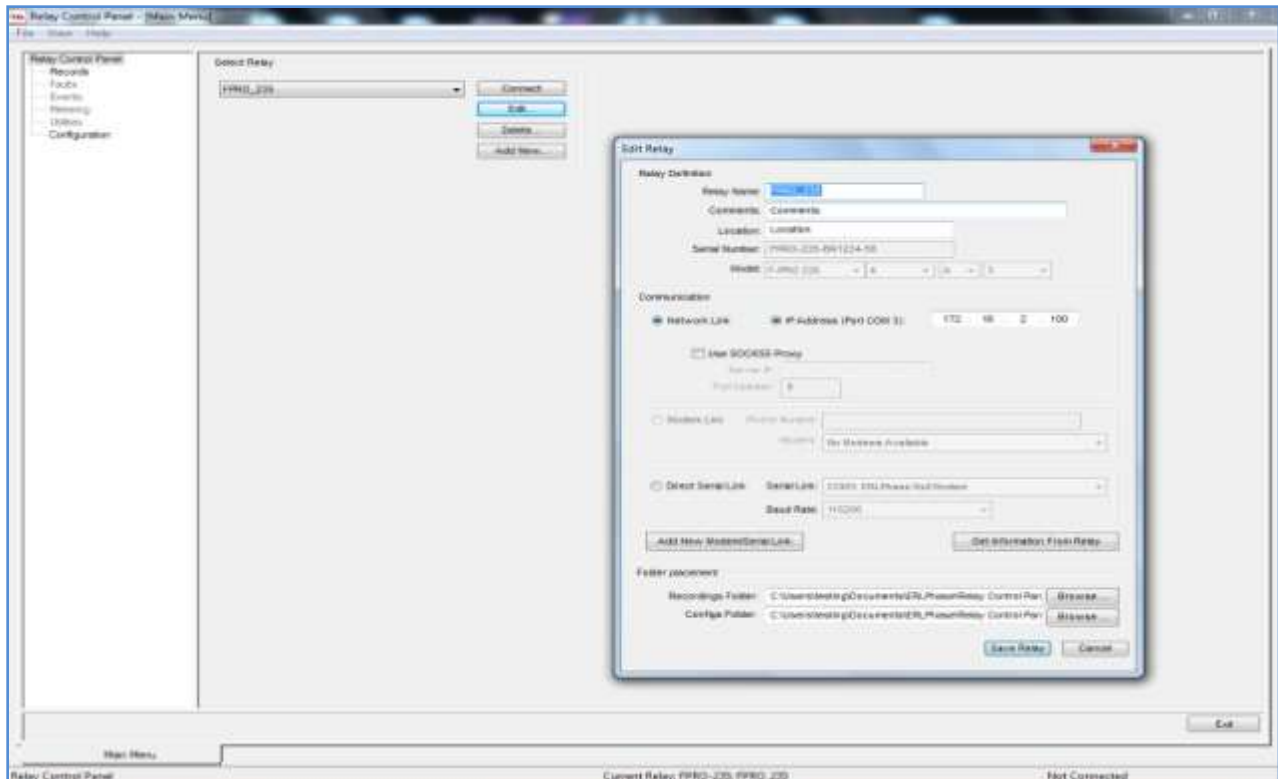

Figure 2.4: USB com port configuration

A Window will appear in that select the "Add" Button.

"Add Hardware Wizard" Window will open, Now click Next twice and click the "Have Disk" button.

Browse the Null_mdm file from the path: C:\Program Files (x86)\ERLPhase\Relay Control Panel

Then click ok and Next.

Select the COM Port at which the relay was connected. Click Next and Finish.

Now come to the "Add New Relay" Window and select the COM # in the Serial Link to which the Relay is connected. The Baud Rate is Default as "115200".

Click the "Get Information From Relay" Button to Collect the Information from Relay. After the information is retrieved, enter relay name and click save button.

2.6 Network Link

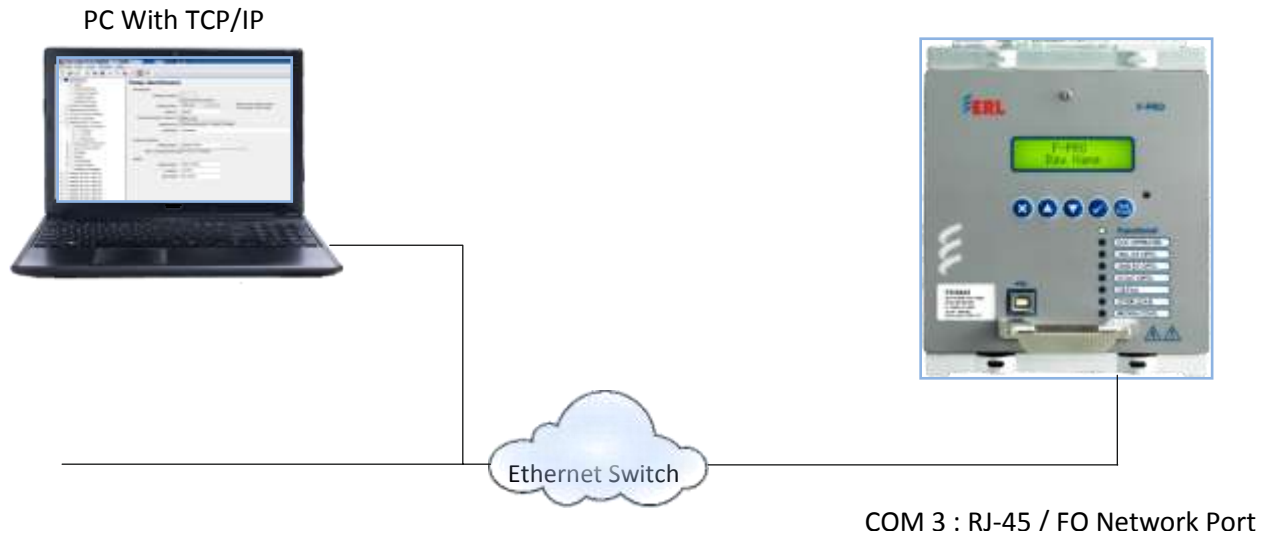

Figure 2.5: Network Link

Access both the relay's user interface and 61850 SCADA services simultaneously with the Ethernet TCP/IP LAN link through the rear network port COM 3. The rear Port 3 is 100BASE-T copper interface with an RJ-45 connector or FO with ST interface.

DNP3 SCADA services can also be accessed over the LAN, for details see "[Communication Port Details](#)" [Table 2.1](#).

Connect to the Ethernet LAN using a Cat 5 or above cable with an RJ-45 connector on both ends in straight fashion or 100BASE-FX 1300 nm, multi-mode optical fiber with an ST style connector

If an FO connector is used on the IED, then an Ethernet switch with an ST and RJ45 connector to communicate with the device.

By default, the COM 3 is assigned with an IP address of 192.168.100.80. If this address is not suitable, it may be modified using Relay's interface accessed through Relay Control Panel or Front LCD display in 'Change/Service mode. If IP address is changed, then the relay will restart automatically.

2.7 Firmware Update

The relay has an update login that can be accessed by a connection through any file transfer protocol. This login is available only from the rear Ethernet COM 3 Port. Login user in to "update" and password is "proup" and transfer the below files in to /usr/apt folder:

- a) erl_update.sh
- b) fpro2k_update
- c) relay_fw_update_msg
- d) relay_restart_msg
- e) rmnologin

Then close the ftp window and Firmware update through LCD-HMI in service mode as shown in figure 2.6.: The relay gets restarted after firmware update.

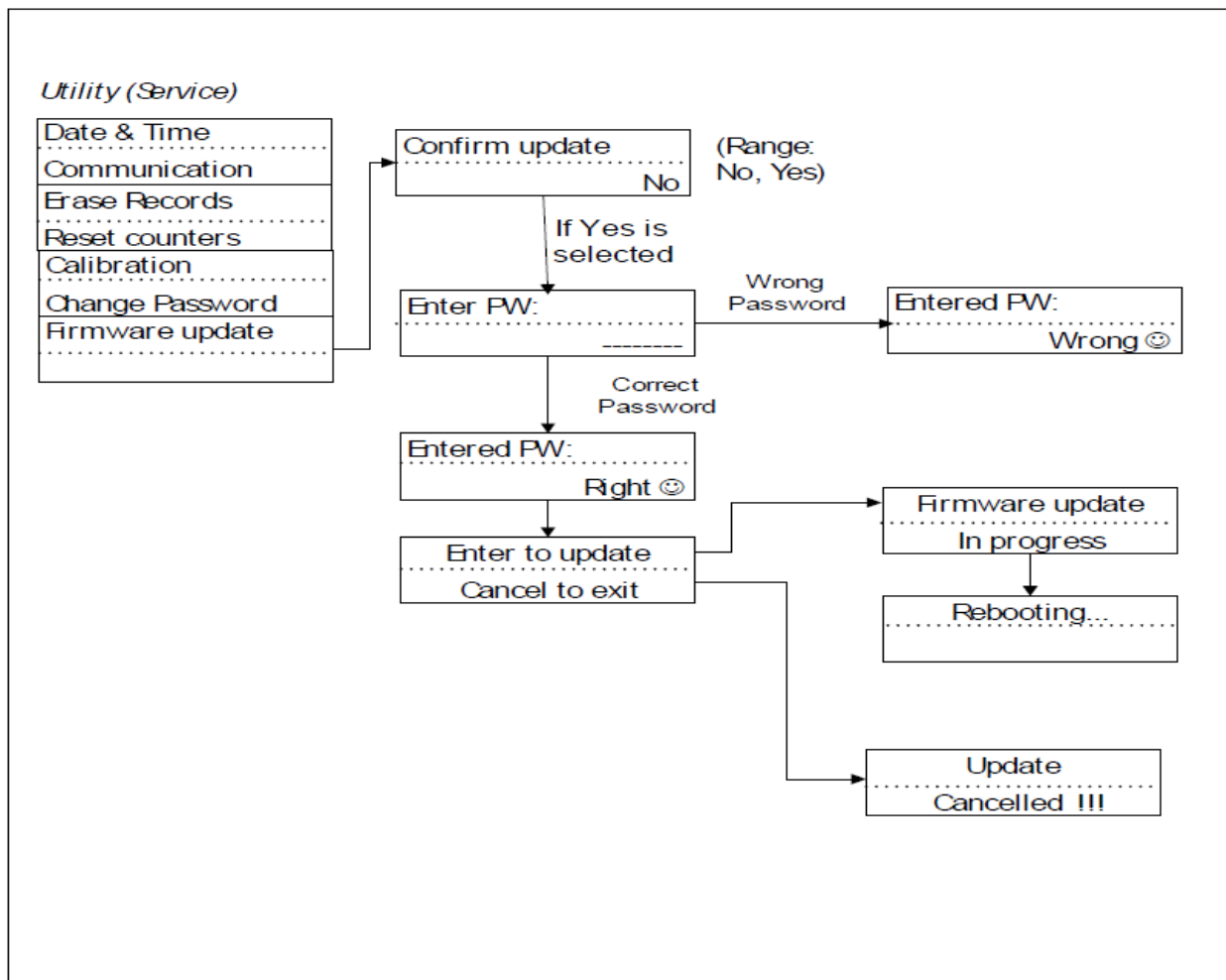

Figure 2.6: Firmware Update

2.8 Accessing the Relay's SCADA Services

The relay supports IEC 60870-5-103 slave, DNP3(Level 2) and Modbus slave SCADA protocols as a standard feature on all F-PRO series relays. The DNP3 is available through a direct serial link or the Ethernet LAN on top of either TCP or UDP protocols. The Modbus implementation supports both Remote Terminal Unit (RTU) binary and ASCII modes and is available through a direct RS485 serial link.

The relay Port COM 2 is dedicated for use with Modbus slave, IEC 60870-5-103 slave or DNP3 serial protocols. The serial port uses standard RS-485 signaling. An external RS-485 <-> RS-232 converter can be used to connect to an RS-232 network.

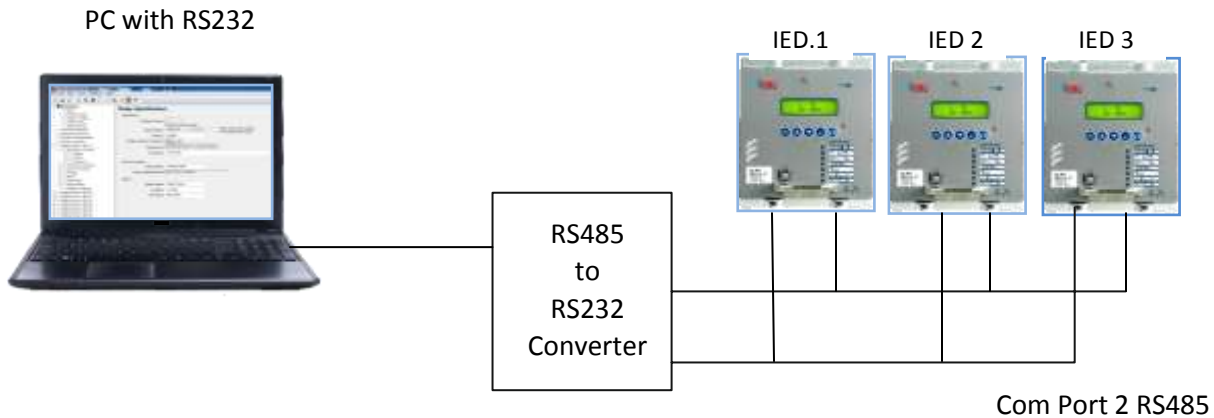

Figure 2.7: RS485 Connection diagram

The DNP3 protocol can also be run across the Ethernet LAN. Both DNP over TCP and DNP over UDP are supported. For details on connecting to the Ethernet LAN see "[Network Link](#)" on [page 2-7](#).

Complete details on the Modbus and IEC 60870-5-103 protocol services can be found in the Appendices, for details see "Modbus RTU Communication Protocol" in [Appendix E](#), "IEC 103 Device Profile" in [Appendix F](#) and DNP3 Device Profile in [Appendix G](#)

Protocol Selection To select the desired SCADA protocol go to F-PRO Offliner SCADA communication section. Select the desired SCADA protocol and set the corresponding parameters.

Communication parameters The serial port's communication parameters are set in the F-PRO Offliner SCADA communication section. Both the baud rate and the parity bit can be configured. The number of data bits and stop bits are determined automatically by the selected SCADA protocol. Modbus ASCII uses 7 data bits. Modbus RTU, IEC 60870-5-103 and DNP3 Serial use 8 data bits. All protocols use 1 stop bit except in the case where either Modbus protocol is used with no parity; this uses 2 stop bits, as defined in the Modbus Standard.

2.9 Communication Port Details

Table 2.1: Communication Port Details		
Location	Port	Function
Front Panel	COM 1	USB-B receptacle, High speed USB 2.0 interface Used for user interface access Default fixed baud rate 115200 N 8 1 (no parity, 8 data bits, 1 stop bit).
Rear Panel	COM 2	RS-485. Used for SCADA communication (MODBUS or IEC103 or DNP3). Default Setting: 9600 N 7 1 (no parity, 7 data bits, 1 stop bit)
Rear Panel	COM 3	RJ-45 receptacle or ST type optical receptacle(factory Configured). 100BASE-T or 100BASE-FX(1300nm, multimode) Ethernet interface. Used for user interface access or IEC61850 or DNP3 SCADA access through Ethernet LAN. SNTP time sync is also selectable.
Rear panel	IRIG-B	BNC receptacle, IRIG-B Interface. Modulated or un-modulated, 65 ohm impedance.

Table 2.2: RS485 Connections to Pins on Relay Port		
Signal Name	Direction PC<-> Relay	Pin # on the Relay Port
A+	↔	26
B-	↔	27
Common		28

Notes: 01) Pins 25 and 27 are tied together internal to the relay with resistor.
02) If no. of IED's connected in daisy chain method, the end unit can be connected with 120Ω load resistance which is in built in the relay (refer wiring diagram [Appendix L](#)).

3 Using the IED (Getting Started)

3.1 Introduction

This section provides information on the start-up sequence and ways to interface with the F-PRO relay. Descriptions of the Front Panel Display, Terminal Mode and Metering Data are provided.

3.2 Start-up sequence

When the power supply is connected, the following initialization initializing sequence takes place:

- After 5 seconds "Booting..." displayed in the LCD
- At 70th second "Loading..." displayed in the LCD
- At 80th second all the LED's blink once and from now onwards the DSP is actively protecting the system.
- At 100th second the Functional Green LED comes ON and it indicates that the relay is capable of recording and communicating with the user.
- Unit Restarted event displayed in the LCD.

3.3 Interfacing with the Relay

The following ways can be used to interface with the relay:

- Front panel display
- Relay Control Panel

3.4 Front Panel Display

The front panel display is the fastest and easiest way of getting information from the relay.

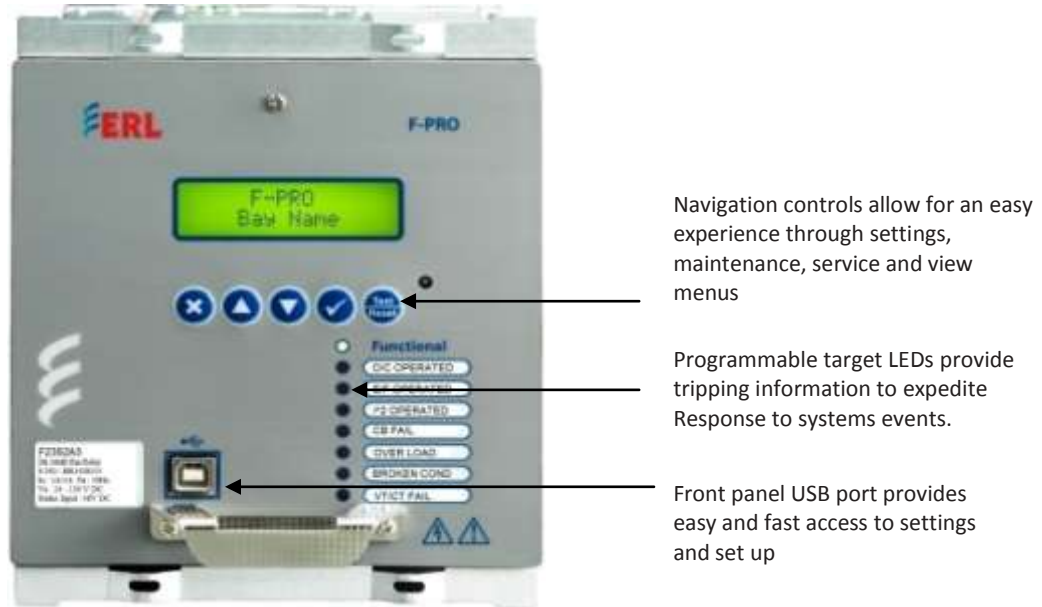

Figure 3.1: Front Panel Display

The display, the 8 LED lights and the 5 push buttons, provide selective information about the relay.

LED Indications

Table 3.1: Description of LED Indications	
LED 1	Indicates the relay is functional. When the Relay Functional green LED comes on, the rear Relay Inoperative contact change to: open and the protective functions become functional.
LED 2 to 8	Programmable for any protection functions, ProLogic, Virtual Inputs and external inputs.

Target LED assignments are the default function but are configurable by the user through the Offliner settings (output matrix configuration → LED Output).

Push Buttons

Table 3.2 Identification of Push Buttons	
Up, Down, Cancel, Enter, Test or Target Reset	Used to Navigate the front panel LCD Screen

Display

The basic menu structure for navigation of the LCD screen is given below:

Table 3.3: Navigation of the LCD Screen		
Main Screen		
	View / Change / Service : Choice Menu	
	Enter Password	
	Main Menu	(V,C,S)
	Configuration	(V,C,S)
	System Parameters	(V,C,S)
	System Freq.	(V,C,S)
	System Freq.	(V,C,S)
	CT Config.	(V,C,S)
	Phase CT Sec.	(V,C,S)
	Phase CT Ratio	(V,C,S)
	VT Config.	(V,C,S)
	Phase VT Sec.	(V,C,S)
	Phase VT Ratio	(V,C,S)
	VT Sec Conn	(V,C,S)
	General	(V,C,S)
	Min Volt Thold	(V,C,S)
	Display Backlight Timeout	(V,C,S)
	Duration	(V,C,S)
	Setting Group	(V,C,S)
	Active:	(V,C,S)
	Edit / View	(V,C,S)
	Functions	(V,C,S)
	Phase U/O Voltage	(V,C,S)
	Fn. 27/59DT-1	(V,C,S)
	Function	(V,C,S)
	Fn. Selection	(V,C,S)
	Measurement I/P	(V,C,S)
	Input Type	(V,C,S)
	Output Gate	(V,C,S)
	Pickup V	(V,C,S)

Table 3.3: Navigation of the LCD Screen		
	Hysteresis	(V,C,S)
	Pickup DTL Delay	(V,C,S)
	Reset DTL Delay	(V,C,S)
	VTS Blocking	(V,C,S)
	Fn. 27/59DT-2	(V,C,S)
	Function	(V,C,S)
	Fn. Selection	(V,C,S)
	Measurement I/P	(V,C,S)
	Input Type	(V,C,S)
	Output Gate	(V,C,S)
	Pickup V	(V,C,S)
	Hysteresis	(V,C,S)
	Pickup DTL Delay	(V,C,S)
	Reset DTL Delay	(V,C,S)
	VTS Blocking	(V,C,S)
	Fn. 27/59DT-3	(V,C,S)
	Function	(V,C,S)
	Fn. Selection	(V,C,S)
	Measurement I/P	(V,C,S)
	Input Type	(V,C,S)
	Output Gate	(V,C,S)
	Pickup V	(V,C,S)
	Hysteresis	(V,C,S)
	Pickup DTL Delay	(V,C,S)
	Reset DTL Delay	(V,C,S)
	VTS Blocking	(V,C,S)
	Fn. 27/59DT-4	(V,C,S)
	Function	(V,C,S)
	Fn. Selection	(V,C,S)
	Measurement I/P	(V,C,S)
	Input Type	(V,C,S)
	Output Gate	(V,C,S)
	Pickup V	(V,C,S)

Table 3.3: Navigation of the LCD Screen		
	Hysteresis	(V,C,S)
	Pickup DTL Delay	(V,C,S)
	Reset DTL Delay	(V,C,S)
	VTS Blocking	(V,C,S)
	Fn. 27/59DT-5	(V,C,S)
	Function	(V,C,S)
	Fn. Selection	(V,C,S)
	Measurement I/P	(V,C,S)
	Input Type	(V,C,S)
	Output Gate	(V,C,S)
	Pickup V	(V,C,S)
	Hysteresis	(V,C,S)
	Pickup DTL Delay	(V,C,S)
	Reset DTL Delay	(V,C,S)
	VTS Blocking	(V,C,S)
	Fn. 27/59DT-6	(V,C,S)
	Function	(V,C,S)
	Fn. Selection	(V,C,S)
	Measurement I/P	(V,C,S)
	Input Type	(V,C,S)
	Output Gate	(V,C,S)
	Pickup V	(V,C,S)
	Hysteresis	(V,C,S)
	Pickup DTL Delay	(V,C,S)
	Reset DTL Delay	(V,C,S)
	VTS Blocking	(V,C,S)
	Fn. 27/59IT-1	(V,C,S)
	Function	(V,C,S)
	Fn. Selection	(V,C,S)
	Measurement I/P	(V,C,S)
	Input Type	(V,C,S)
	Output Gate	(V,C,S)
	Pickup V	(V,C,S)

Table 3.3: Navigation of the LCD Screen		
	Hysteresis	(V,C,S)
	Curve Type	(V,C,S)
	TMS	(V,C,S)
	Pickup DTL Delay	(V,C,S)
	Reset DTL Delay	(V,C,S)
	Constant A	(V,C,S)
	Constant B	(V,C,S)
	Constant P	(V,C,S)
	VTS Blocking	(V,C,S)
	Fn. 27/59IT-1	(V,C,S)
	Function	(V,C,S)
	Fn. Selection	(V,C,S)
	Measurement I/P	(V,C,S)
	Input Type	(V,C,S)
	Output Gate	(V,C,S)
	Pickup V	(V,C,S)
	Hysteresis	(V,C,S)
	Curve Type	(V,C,S)
	TMS	(V,C,S)
	Pickup DTL Delay	(V,C,S)
	Reset DTL Delay	(V,C,S)
	Constant A	(V,C,S)
	Constant B	(V,C,S)
	Constant P	(V,C,S)
	VTS Blocking	(V,C,S)
	Direction	(V,C,S)
	Fn. 67	(V,C,S)
	Angle	(V,C,S)
	Voltage	(V,C,S)
	2 Out of 3 Logic	(V,C,S)
	VTS Block	(V,C,S)
	Fn. 67N	(V,C,S)
	Angle	(V,C,S)
	Voltage	(V,C,S)

Table 3.3: Navigation of the LCD Screen		
	Input	(V,C,S)
	VTS Block	(V,C,S)
	Phase OC	(V,C,S)
	Fn. 50/67-1	(V,C,S)
	Function	(V,C,S)
	Direction	(V,C,S)
	Pickup Current	(V,C,S)
	Pickup Delay	(V,C,S)
	Inrush Blocking	(V,C,S)
	Fn. 50/67-2	(V,C,S)
	Function	(V,C,S)
	Direction	(V,C,S)
	Pickup Current	(V,C,S)
	Pickup Delay	(V,C,S)
	Inrush Blocking	(V,C,S)
	Fn. 51/67-1	(V,C,S)
	Function	(V,C,S)
	Direction	(V,C,S)
	Pickup Current	(V,C,S)
	Curve	(V,C,S)
	TMS	(V,C,S)
	Pickup DTL delay	(V,C,S)
	Reset Delay	(V,C,S)
	Reset DTL Delay	(V,C,S)
	Constant A	(V,C,S)
	Constant B	(V,C,S)
	Constant p	(V,C,S)
	Constant TR	(V,C,S)
	Inrush Blocking	(V,C,S)
	Fn. 51/67-2	(V,C,S)
	Function	(V,C,S)
	Direction	(V,C,S)
	Pickup Current	(V,C,S)
	Curve	(V,C,S)

Table 3.3: Navigation of the LCD Screen		
	TMS	(V,C,S)
	Pickup DTL delay	(V,C,S)
	Reset Delay	(V,C,S)
	Reset DTL Delay	(V,C,S)
	Constant A	(V,C,S)
	Constant B	(V,C,S)
	Constant p	(V,C,S)
	Reset TR	(V,C,S)
	Inrush Blocking	(V,C,S)
	Neutral OC	(V,C,S)
	Fn. 50N/67N-1	(V,C,S)
	Function	(V,C,S)
	Direction	(V,C,S)
	Pickup Current	(V,C,S)
	Pickup Delay	(V,C,S)
	Inrush Blocking	(V,C,S)
	Fn. 50N/67N-2	(V,C,S)
	Function	(V,C,S)
	Direction	(V,C,S)
	Pickup Current	(V,C,S)
	Pickup Delay	(V,C,S)
	Inrush Blocking	(V,C,S)
	Fn. 51N/67N-1	(V,C,S)
	Function	(V,C,S)
	Direction	(V,C,S)
	Pickup Current	(V,C,S)
	Curve	(V,C,S)
	TMS	(V,C,S)
	Pickup DTL delay	(V,C,S)
	Reset Delay	(V,C,S)
	Reset DTL Delay	(V,C,S)
	Constant A	(V,C,S)
	Constant B	(V,C,S)
	Constant p	(V,C,S)

Table 3.3: Navigation of the LCD Screen		
	Constant TR	(V,C,S)
	Inrush Blocking	(V,C,S)
	Fn. 51N/67N-2	(V,C,S)
	Function	(V,C,S)
	Direction	(V,C,S)
	Pickup Current	(V,C,S)
	Curve	(V,C,S)
	TMS	(V,C,S)
	Pickup DTL delay	(V,C,S)
	Reset Delay	(V,C,S)
	Reset DTL Delay	(V,C,S)
	Constant A	(V,C,S)
	Constant B	(V,C,S)
	Constant p	(V,C,S)
	Constant TR	(V,C,S)
	Inrush Blocking	(V,C,S)
	Neg. Seq. OC	(V,C,S)
	Fn. 46/50	(V,C,S)
	Function	(V,C,S)
	Pickup Current	(V,C,S)
	Pickup Delay	(V,C,S)
	Fn. 46/51	(V,C,S)
	Function	(V,C,S)
	Pickup Current	(V,C,S)
	Curve	(V,C,S)
	TMS	(V,C,S)
	Pickup DTL delay	(V,C,S)
	Reset Delay	(V,C,S)
	Reset DTL Delay	(V,C,S)
	Constant A	(V,C,S)
	Constant B	(V,C,S)
	Constant p	(V,C,S)
	Constant TR	(V,C,S)
	Thermal OL	(V,C,S)
	Fn. 49	(V,C,S)

Table 3.3: Navigation of the LCD Screen		
	Function	(V,C,S)
	Therm. OL	(V,C,S)
	Time Constant	(V,C,S)
	NegSeq. weighing	(V,C,S)
	Therm. OL Alarm	(V,C,S)
	Alarm % Th	(V,C,S)
	CB Fail	(V,C,S)
	Fn. 50 BF	(V,C,S)
	Function	(V,C,S)
	Pickup Current	(V,C,S)
	Pickup Delay-1	(V,C,S)
	Pickup Delay-2	(V,C,S)
	Broken Conductor	(V,C,S)
	Fn. 46BC	(V,C,S)
	Function	(V,C,S)
	I2/I1 Pickup	(V,C,S)
	Pickup Delay	(V,C,S)
	Supervision	(V,C,S)
	Fn. 60 CTS	(V,C,S)
	Function	(V,C,S)
	VNPS Pickup	(V,C,S)
	INPS Pickup	(V,C,S)
	Pickup Delay	(V,C,S)
	Fn. 60 VTS	(V,C,S)
	Function	(V,C,S)
	I1 Blocking	(V,C,S)
	310 Blocking	(V,C,S)
	NegSeq. Monitor	(V,C,S)
	VNPS	(V,C,S)
	INPS	(V,C,S)
	Trip Circuit Supervision	(V,C,S)
	Fn. 74 TCS-1	(V,C,S)
	Function	(V,C,S)
	Name	(V,C,S)
	Drop-Off Delay	(V,C,S)
	Fn. 74 TCS-2	(V,C,S)

Table 3.3: Navigation of the LCD Screen		
	Function	(V,C,S)
	Name	(V,C,S)
	Drop-Off Delay	(V,C,S)
	Inrush Detection	(V,C,S)
	Fn. 81HBL2	(V,C,S)
	Function	(V,C,S)
	Cross Blocking	(V,C,S)
	Pickup I2nd	(V,C,S)
	Auto Reclose	(V,C,S)
	Fn. 79	(V,C,S)
	Function	(V,C,S)
	Number of Shots	(V,C,S)
	1st Reclose--T1	(V,C,S)
	2nd Reclose--T2	(V,C,S)
	3rd Reclose--T3	(V,C,S)
	4th Reclose--T4	(V,C,S)
	Close Time Tp	(V,C,S)
	Reclaim Time Td	(V,C,S)
	Init. Rst. TDI	(V,C,S)
	Block Rst. TDB	(V,C,S)
	CB Monitoring	(V,C,S)
	Fn. I^2t	(V,C,S)
	Function	(V,C,S)
	I^2t Limit	(V,C,S)
	Disturbance Record Settings	(V,C,S)
	Record Length	(V,C,S)
	Pre--trigger	(V,C,S)
	Meters	(V,C,S)
	Meter Display Option	(V,C,S)
	Display Option	(V,C,S)
	Analog	(V,C,S)
	Va Mag:	(V,C,S)
	Va Ang:	(V,C,S)
	Vb Mag:	(V,C,S)
	Vb Ang:	(V,C,S)

Table 3.3: Navigation of the LCD Screen		
	Vc Mag:	(V,C,S)
	Vc Ang:	(V,C,S)
	Vn Mag:	(V,C,S)
	Vn Ang:	(V,C,S)
	Ia Mag:	(V,C,S)
	Ia Ang:	(V,C,S)
	Ib Mag:	(V,C,S)
	Ib Ang:	(V,C,S)
	Ic Mag:	(V,C,S)
	Ic Ang:	(V,C,S)
	In Mag:	(V,C,S)
	In Ang:	(V,C,S)
	V1 Mag:	(V,C,S)
	V2 Mag:	(V,C,S)
	V0 Mag:	(V,C,S)
	I1 Mag:	(V,C,S)
	I2 Mag:	(V,C,S)
	I0 Mag:	(V,C,S)
	Real Power	(V,C,S)
	Reactive Power	(V,C,S)
	Frequency	(V,C,S)
	Power factor	(V,C,S)
	Thermal State	(V,C,S)
	I ² t Accumulated	(V,C,S)
	I ² t Last Operation	(V,C,S)
	Digital	(V,C,S)
	EI Status	(V,C,S)
	EI1- EI1	(V,C,S)
	EI2- EI2	(V,C,S)
	EI3- EI3	(V,C,S)
	EI4- EI4	(V,C,S)
	DO Status	(V,C,S)

Table 3.3: Navigation of the LCD Screen		
	RL1- RL 1	(V,C,S)
	RL2- RL 2	(V,C,S)
	RL3- RL 3	(V,C,S)
	RL4- RL 4	(V,C,S)
	RL5- RL 5	(V,C,S)
	RL6- RL 6	(V,C,S)
	RL7- RL 7	(V,C,S)
	RL8- RL 8	(V,C,S)
	Records	(V,C,S)
	View Events	(V,C,S)
	Events	(V,C,S)
	View Faults	(V,C,S)
	Faults	(V,C,S)
	Utilities	(V,C,S)
	Time	(V,C,S)
	Date	(V,C,S)
	Date: DD/MM/YYYY	(V,C,S)
	Time	(V,C,S)
	Time: HH:MM:SS	(V,C,S)
	Display Time As	(V,C,S)
	Display Time as	(V,C,S)
	DST	(V,C,S)
	DST start Month	(V,C,S)
	DST start	(V,C,S)
	DST start Hour	(V,C,S)
	DST end Month	(V,C,S)
	DST end	(V,C,S)
	DST end Hour	(V,C,S)
	UTC Offset	(V,C,S)
	UTC Offset	(V,C,S)
	SNTP	(V,C,S)
	Enable SNTP	(V,C,S)
	Poll Interval	(V,C,S)
	Timeout	(V,C,S)
	SNTP Server	(V,C,S)
	Enable 2nd SNTP	(V,C,S)
	2nd SNTP Server	(V,C,S)
	Communication	(V,C,S)

Table 3.3: Navigation of the LCD Screen		
	USB	(V,C,S)
	Host: Serial Dadget	(V,C,S)
	RS485(COM 2)	(V,C,S)
	Protocol	(V,C,S)
	Baud Rate	(V,C,S)
	Parity	(V,C,S)
	Relay Address	(V,C,S)
	Ethernet(COM 3)	(V,C,S)
	IP Address	(V,C,S)
	Port	(V,C,S)
	Subnet Mask	(V,C,S)
	Default Gateway	(V,C,S)
	MAC Address	(V,C,S)
	Protocol Selection	(V,C,S)
	Protocol	(V,C,S)
	Modbus-RTU/ASCII	(V,C,S)
	Relay Address	(V,C,S)
	Baud Rate	(V,C,S)
	Protocol	(V,C,S)
	IEC-103 Slave	(V,C,S)
	Relay Address	(V,C,S)
	Class 2 Update	(V,C,S)
	Measurand Max Range	(V,C,S)
	Baud Rate	(V,C,S)
	Parity	(V,C,S)
	Protocol	(V,C,S)
	DNP3 Level2 - Ser	(V,C,S)
	Relay Address	(V,C,S)
	Baud Rate	(V,C,S)
	Parity	(V,C,S)
	Data Link Time Out	(V,C,S)
	Protocol	(V,C,S)
	DNP3 Level2 - TCP	(V,C,S)
	Relay Address	(V,C,S)
	Keep-Alive Time Out	(V,C,S)
	No. Of Masters	(V,C,S)
	Connection Based On	(V,C,S)
	Master 1 IP Address	(V,C,S)

	Master 1 Port	(V,C,S)
	Master 2 IP Address	(V,C,S)
	Master 2 Port	(V,C,S)
	Master 3 IP Address	(V,C,S)
	Master 3 Port	(V,C,S)
	Protocol	(V,C,S)
	DNP3 Level2 - UDP	(V,C,S)
	Relay Address	(V,C,S)
	UDP Response	(V,C,S)
	Master 1 IP Address	(V,C,S)
	Master 1 Port	(V,C,S)
	Erase Records	(C,S)
	Erase Event Rec	(C,S)
	Erase Fault Rec	(C,S)
	Erase DR	
	Reset Counters	(C,S)
	Present Value	(C,S)
	New Value	(C,S)
	Calibration	(C,S)
	Voltage Channels	(C,S)
	Calibrate VA?	(C,S)
	Calibrate VB?	(C,S)
	Calibrate VC?	(C,S)
	Current Channels	(C,S)
	Information Ensure 1A AC is applied	(C,S)
	Calibrate IA?	(C,S)
	Calibrate IB?	(C,S)
	Calibrate IC?	(C,S)
	Password Settings	(V,C,S)
	Change PW	(S)
	New Change PW	(S)
	New Service PW	(S)
	PW Access Timer	(V,S)
	PW Access Timer	(V,S)
	PW Enable / Disable	(V,S)
	PW Enable	(V,S)
	Firmware Update	(S)
	Confirm Update	(S)
	Test Mode	(S)
	Test Mode Selection	(S)

Table 3.3: Navigation of the LCD Screen		
	Unit Identification	(V,C,S)
	Product Version	(V,C,S)
	Serial Number	(V,C,S)
	Unit ID	(V,C,S)
	Firmware Ver.	(V,C,S)
	Settings Date	(V,C,S)
	Settings Ver.	(V,C,S)
	RCP Ver.	(V,C,S)
	Comments	(V,C,S)
	Station Name	(V,C,S)
	Location	(V,C,S)
	Bay name	(V,C,S)
	Load Date	(V,C,S)

Where the access levels required to access each are indicated

V: view

C: change

S: service

To login into the LCD menu structure, follow these steps:



Figure 3.2: Main Screen

In the Main Screen, Press *Enter* Key.

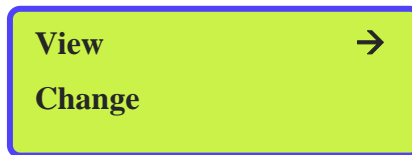

Figure 3.3: View / Change / Service: Choice Menu

In the View / Change / Service: Choose Menu screen, choose desired access level, and Press *Enter* key.

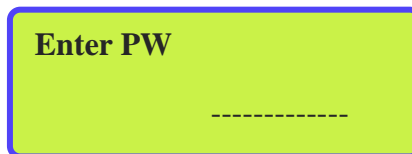

Figure 3.4: Enter Password

In the Enter PW screen, enter appropriate six digit password and Press *Enter* key on the return character (right bottom one)

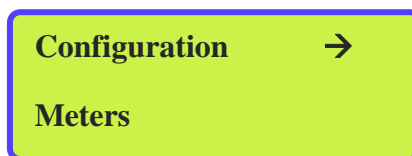

Figure 3.5: Main Menu

The Main Menu screen should appear.

Note: The default passwords are below (Don't include the quotation marks):

Access Level	Password
View	no password for View access in LCD
Change	Change
Service	Service

Password can contain ~ ! @ # \$ % ^ & * () _ + = { } [] ; : " ' , < > ? / \ () 0-9 a-z and A-Z

3.5 Relay Control Panel

RCP is used for all user interfaces with IED online. A short description of the RCP configuration to connect to a relay is given here. Please refer to the Relay Control Panel User Manual for details. Follow this sequence to configure RCP for USB link to the relay:

1. Execute
"Relay Control Panel.exe"
2. Execute
"F-PRO Offliner.exe"
3. Install
"Null Modem Driver" - Please refer to the Relay Control Panel User Manual for details.
4. Run Relay Control Panel.

Go to:

Start > All Programs > ERLPhase > Relay Control Panel > Relay Control Panel

First time RCP is run.

Hit *Add New*.

"Add New Relay"

Choose *Communication > Direct Serial Link*.

Select correct serial link and baud rate.

Click Get Information from Relay.

Then RCP will communicate with the F-PRO-235 and retrieve information to fill required fields.

When this is done, hit *Save Relay*.

If the window "Relay already exists..." pops up, user may need to re- name the relay changing the "Relay Name" in the "Relay Definition" category, before saving.

After first time, in "Select Relay", choose relay and hit *Connect*.

In "Relay Password Prompt"

Choose desired access level, enter appropriate password

Note: Default passwords are listed below (Don't include the quotation marks)

View Access "view"

Change Access "change"

Service Access "service"

Relay Control Panel Structure

The basic structure of the Relay Control Panel information, including basic actions available, is given below:

Table 3.4: Relay Control Panel Structure				
		View	Change	Service
Relay Control Panel				
	Records	View	Trigger Fault	Trigger Fault
		View	Trigger Event	Trigger Event
	Faults	View	Clear Faults	Clear Faults
	Events	View	Clear Faults	Clear Faults
Metering				
	Analog Input	View	View	View
	I ² t	View	View	View
	Status (EI)	View	View	View
	Protection status	View	View	View
	Outputs (Status DO)	View	View	View
ProLogic				
Virtual				
Utilities				
	Unit Identification	View	View	View
	Settings Group	N/A	Save	Save
	Time	N/A	Save	Save
	Analog Input Calibration	N/A	Calibrate offset and gain	Calibrate offset and gain
	Virtual Inputs	N/A	Latch/Pulse	Latch/Pulse
	Toggle Outputs	N/A	N/A	Close/Open
	Set/Reset I ² t	N/A	Save	Save
	Password	N/A	N/A	Save
Configuration				
	Present Settings	(Get From Relay)	(Get From Relay)	(Get From Relay)
	Saved Settings	View	(Load to Relay)	(Load to Relay)

Notice that some options are not available (N/A) depending on the access level

4 Protection Functions and Specifications

4.1 Protection and Recording functions

Introduction

This section describes the equations and algorithms that are defined in the F-PRO235 relay Protection functions.

The available functions are 67, 67N, 27/59DT (1-6), 27/59IT (1-2), 50/67 (1-2), 51/67 (1-2), 50N/67N (1-2), 51N/67N (1-2), 46/50, 46/51, 49, 50BF, 46BC, 60CTS, 60VTS, 74TCS (1-2) 81HBL2, I²t and 79. These functions are explained below with setting ranges and logic diagrams.

The protection functions have user-settable pick-up and drop-off delays. The Alarm and Trip outputs are initiated when the function's input value exceeds the set pick-up value. When Alarms or Trips occur, programmable front LEDs turn on and output contacts close. The mapping of protection functions to LEDs and output contacts is performed in the Output Matrix. The output contacts and LEDs are user configurable for Self Reset or Hand Reset.

67 Phase Directional Element

Power systems may have various circuit combinations such as parallel feeders, transformers, ring main circuits and circuits with sources on either end. In these cases faults can occur in any circuit and fault current can flow in either direction. It is necessary to restrict breaker tripping to a particular direction to avoid mis-operation of a healthy system.

For the relay to determine direction (forward or reverse), the reference polarization signal and the direction boundary must be defined. Generally, voltages are used as the reference since the angles remain constant in all cases. F-PRO relays use the cross polarization technique for directional sensing. Voltage polarization for the phase-fault elements is achieved by using the quadrature voltage. Each phase current is compared to the voltage between the other two phases (IA compared to VBC, IB compared to VCA, IC compared to VAB).

There are four settings used to govern the directional element:

- Characteristic angle
- Minimum Voltage
- Two –Out-Of- Three Logic
- VTS Blocking

Characteristic angle

When a fault occurs in the system, in general, current lags the voltage by an angle corresponding to the system X/R ratio. Therefore it is required to set the characteristic angle according to the equipment which the overcurrent relay is protecting. The forward and reverse regions are determined based on the characteristic angle. The total 360° region is divided into two exact halves, one half is forward and one half is reverse. A Blind Zone is introduced as the 5° region on either side.

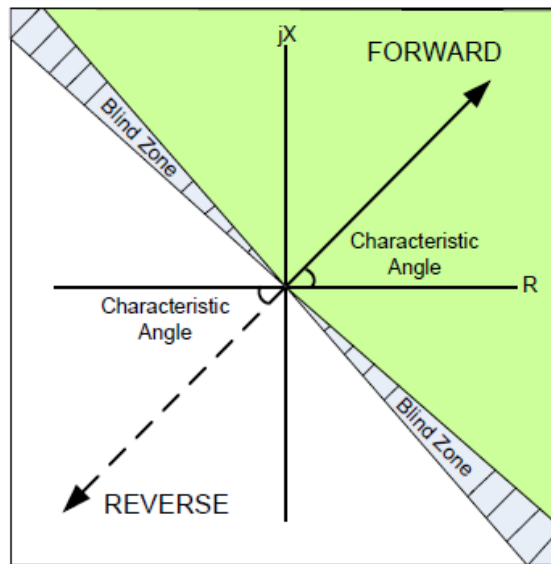

Figure 4.1: Directional Forward/Reverse Zone

Minimum Voltage

In the F-PRO, the directional overcurrent element has a settable minimum voltage pick-up level. This is the minimum polarization voltage to enable directional element operation. This helps to avoid mis-operation during normal operation.

Two-Out-Of-Three Logic

In the F-PRO, the directional overcurrent element has a settable minimum voltage pick-up level. This is the minimum polarization voltage to enable directional element operation. This helps to avoid mis-operation during normal operation.

VTS Blocking

In the event of a VT fuse fail, the relay does not have a polarizing quantity to determine direction. In this case, the element may be set to operate as non-directional or it may be set to block.

Directional Overcurrent Stages

The F-PRO directional overcurrent has four stages. The first two stages may be set to time delayed or instantaneous operations. The third and fourth stages may be set to have IDMTL, time delayed or instantaneous operations.

Table 4.1: Directional Over current Element 67	
Setting Description	Range
Characteristic Angle	+95 to -95 degrees
Minimum Voltage	1.0 to 40 V
2 Out of 3 Logic	Enable/Disable
VTS Blocking	Enable/disable/Non Directional

67N Directional Function for Neutral Overcurrent

In a solidly earthed system the neutral points of the power transformers are connected directly to earth to reduce overvoltage and facilitate fault detection. The disadvantage of solid earthing is that fault currents can be very high and must be disconnected quickly. Since the impedance of the source is normally very low, fault current varies greatly in magnitude depending on the location of the fault. Selective isolation of a faulty section is therefore possible via time/current graded earth fault over current protection. Fault current is detected by measuring the system residual current.

In an interconnected system, where fault current can flow in either direction, directional earth fault relays are applied. The fault causes a residual voltage to be generated, and this can be used for directional polarization. This can be selected in measurement input.

Measurement Input

The F-PRO 67N Directional Function provides two user selectable polarization methods:

- Zero sequence voltage polarization / residual voltage polarization (ZPS)
- Negative sequence voltage polarization (NPS)

Zero Sequence Polarization

Residual voltage is generated during earth fault conditions in power system. This voltage is commonly used to polarize directional earth fault elements. Relay internally derives $3V_0$ voltage for directionality.

Negative Sequence Polarization

In some applications zero sequence polarization cannot be adaptive. In such cases negative sequence polarization can be used. This will help in using the relay in parallel lines with mutual impedance.

Minimum Voltage

The Minimum Voltage is a user settable voltage level used to determine the pick-up level for the directional earth fault elements. It is possible that minimum percentage of residual voltage will be present under normal system conditions such as system imbalances, VT mismatch and tolerance and relay error.

Characteristic angle

When a fault occurs in the system, in general, current lags the voltage by an angle corresponding to the system X/R ratio. Therefore it is required to set the characteristic angle according to the equipment which the overcurrent relay is protecting. The forward and reverse regions are determined based on the characteristic angle. The total 360° region is divided into two exact halves, one half is forward and one half is reverse. A Blind Zone is introduced as the 5° region on either side.

VTS Blocking

In the event of a VT fuse fail, the relay does not have a polarizing quantity to determine direction. In this case, the element may be set to operate as non-directional or it may set to block.

Table 4.2: Directional Overcurrent Element 67N	
Setting Description	Range
Characteristic Angle	+95 to -95 degrees
Minimum Voltage	0.3 to 40 V
Measurement Input	ZPS/NPS
VTS Blocking	Enable/disable/Non Directional

27/59 DT Phase Definite Time Under / Over Voltage

The Phase Definite time (instantaneous) Under/Over voltage function has six stages. Each individual stage consists of both time delayed and instantaneous protection.

This relay provides protection against under or over voltage from bus/line PT's.

Under Voltage Whenever the injected voltage value reaches the **same** or **below** the precise pick-up value, this function operates after a set time delay. The drop-out value of this function mainly depends on the % hysteresis.

Over Voltage Whenever the injected voltage value reaches the **same** or **above** the precise pick-up value, this function operates after a set time delay. The drop-out value of this function mainly depends on the % hysteresis.

Note: Both of these functions should satisfy the logic gates (ie. OR, AND). 60VTS function can block the UV or OV functions when defined in settings.

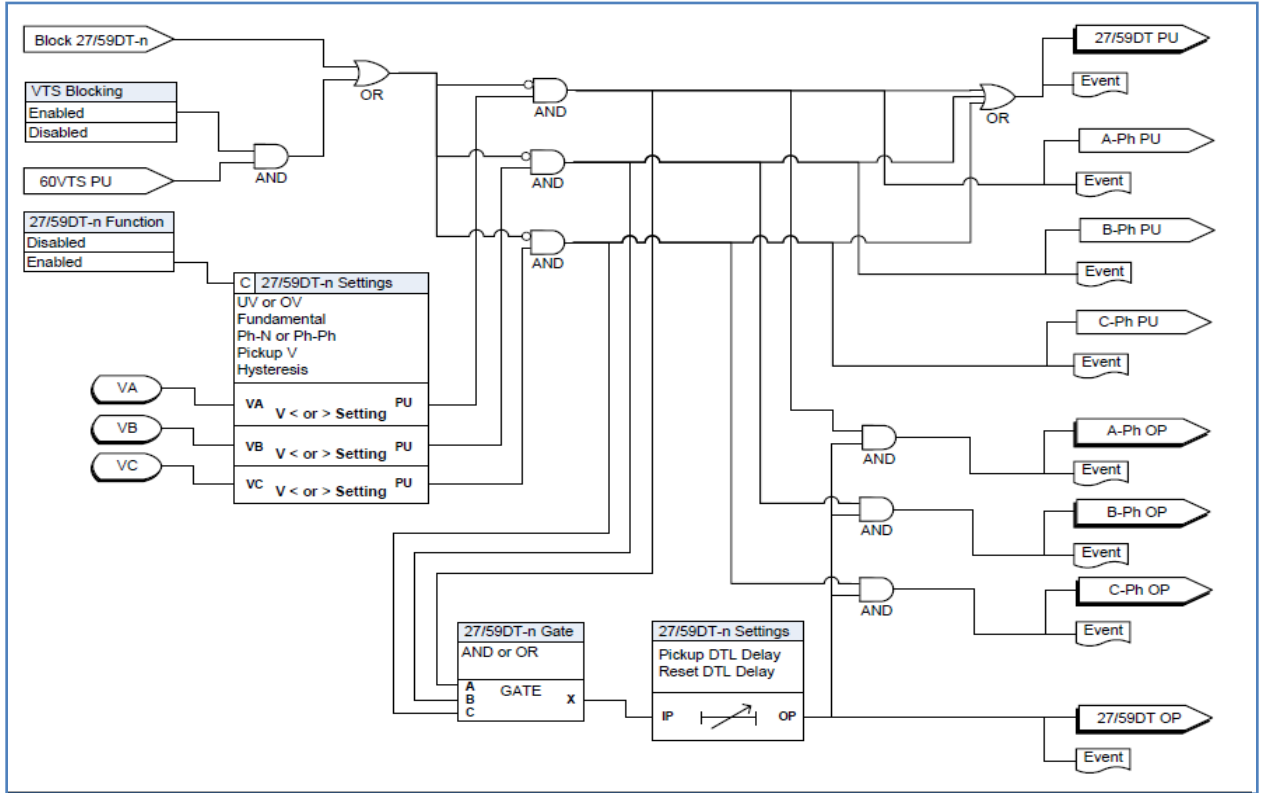

Figure 4.2: Logic Diagram of 27/59 DT Function

Table 4.3: 27/59DT Definite Time Under/Over Voltage Settings (No. of Stages - 2)	
Setting Description	Range
Function Activation	Enable/Disable
Function Selection	UV / OV
Measurement Input	Fundamental
Input Type	Ph-N / Ph-Ph
Output Gate	AND / OR
Pickup V	3.0 to 250.0V
Hysteresis	1% to 80%
Pickup DTL Delay	0.00 to 999.99 Seconds
Reset DTL Delay	0.00 to 999.99 Seconds
VTS Blocking	Enable/Disable

27/59 IT Phase Inverse Time Under /Over Voltage

The Phase inverse time Under/Over voltage function has two stages. Each individual stage consists of both time delayed and instantaneous protection.

This relay provides protection against under or over voltage from bus/line PT's. It is comprised of DTL, IEC standard, extreme, long time inverse curve and user defined curve.

Under Voltage Whenever the injected voltage value reaches the **same** or **below** the precise pick-up value, this function gets operated based on curve settings. The drop-out value of this function mainly depends on the % hysteresis.

Over Voltage Whenever the injected voltage value reaches the **same** or **above** the precise pick-up value, this function gets operated based on curve settings. The drop-out value of this function mainly depends on the % hysteresis.

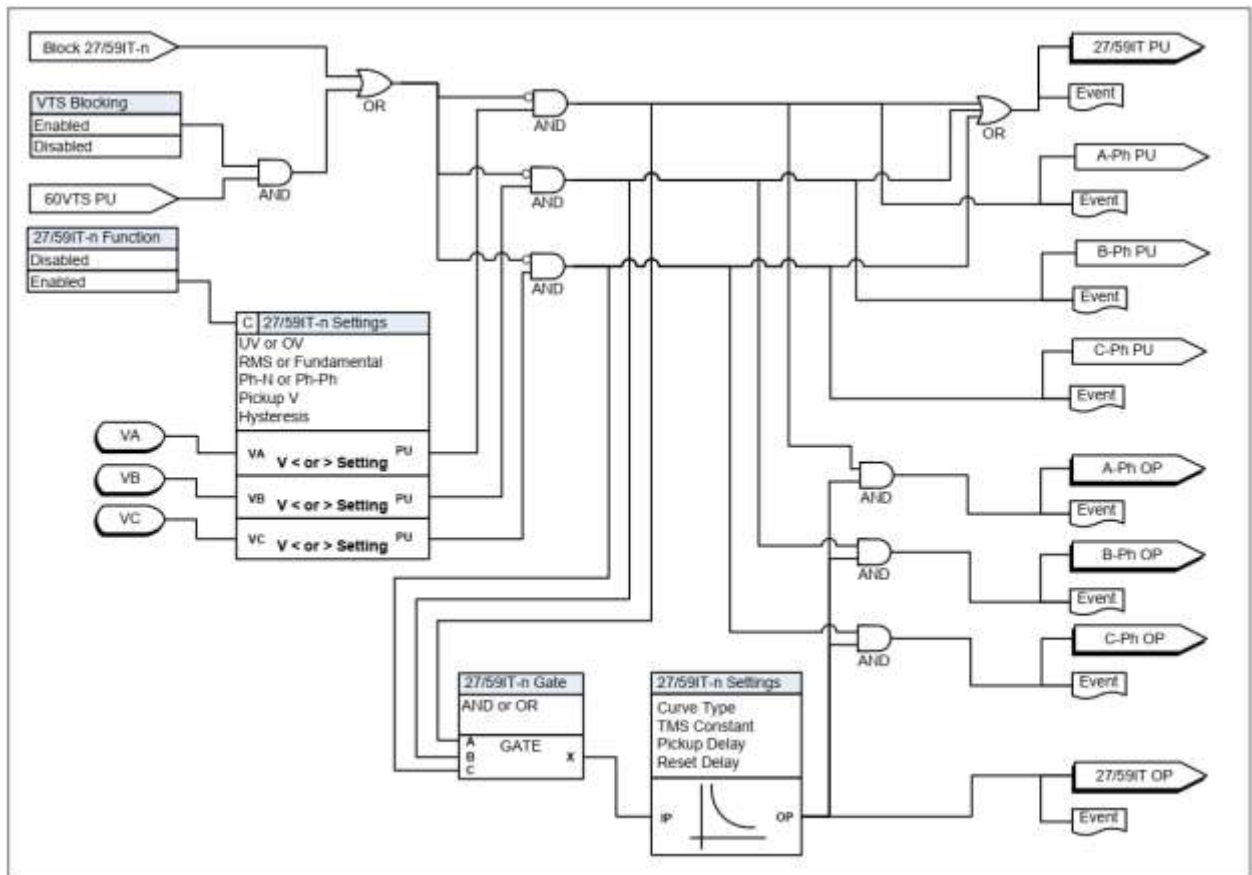

Figure 4.3: Logic Diagram of 27/59 IT Function

$$27\text{IT(UV)} \quad T(V) = TMS \left[B + \frac{A}{1 - \left(\frac{V}{V_{Pickup}} \right)^p} \right] \quad 59\text{IT(OV)} \quad T(V) = TMS \left[B + \frac{A}{\left(\frac{V}{V_{Pickup}} \right)^p - 1} \right]$$

Operate & Reset time of the inverse characteristics can be calculated using the respective formulas presented above.

Table 4.3: IEC Curves				
Sl.No.	Characteristic	A	B	p
1	Definite Time Lag	1.0	1.0	1.0
2	IEC Standard Inverse	1.0	0.0	1.0
3	IEC Extreme Inverse	40.0	1.0	2.0
4	IEC Long Time Inverse	5.0	2.0	2.0
5	User-defined	0.10 to 50.0	0.0 to 10.0	0.1 to 10.0

Table 4.4: 27/59 IT Inverse Time Under / Over Voltage Settings (No. of Stages - 2)	
Setting Description	Range
Function Activation	Enable / Disable
Function Selection	UV / OV
Measurement Input	Fundamental
Input Type	Ph-N / Ph-Ph
Output Gate	AND / OR
Pickup V	3.0 to 250.0 V
Hysteresis	1% to 80%
Curve Type	For details see Table 4.9 "IEC Curves"
TMS	0.01 to 10.00
Pickup DTL Delay	0.00 to 999.99 seconds
Reset DTL Delay	0.0 to 999.99 seconds (applicable if DTL reset is chosen)
A	0.1 to 50.0 (applicable only for user defined characteristics)
B	0.0 to 10.0 (applicable only for user defined characteristics)
P	0.1 to 10.0 (applicable only for user defined characteristics)
VTS Blocking	Enable/disable

50/67 Phase Overcurrent

The Phase Overcurrent function (50/67) provides instantaneous or definite time lag protection to the protected equipment. The current and time settings for the operation of the function are user defined. This function has two elements, 50/67-1 and 50/67-2, both of which can be configured independently as required. Each function has independent directional settings (Non-directional, forward or reverse). Each phase is compared with the set value after current filtering. If the measured current is greater than the set pick-up value, the relay will operate after the set time delay.

The function has an additional "Inrush Blocking" feature. This blocks the operation of the function when the second harmonic current is present over the fundamental. This allows the relay to be used in transformer applications.

Each element (50/67-1, 50/67-2) can be independently inhibited via an external input status which can be configured from the input matrix. This is useful in comprehensive blocking schemes.

The Metering menu provides the current and voltage values and their phase angles. The correctness of the polarity of the directional overcurrent element should be verified on the metering screens.

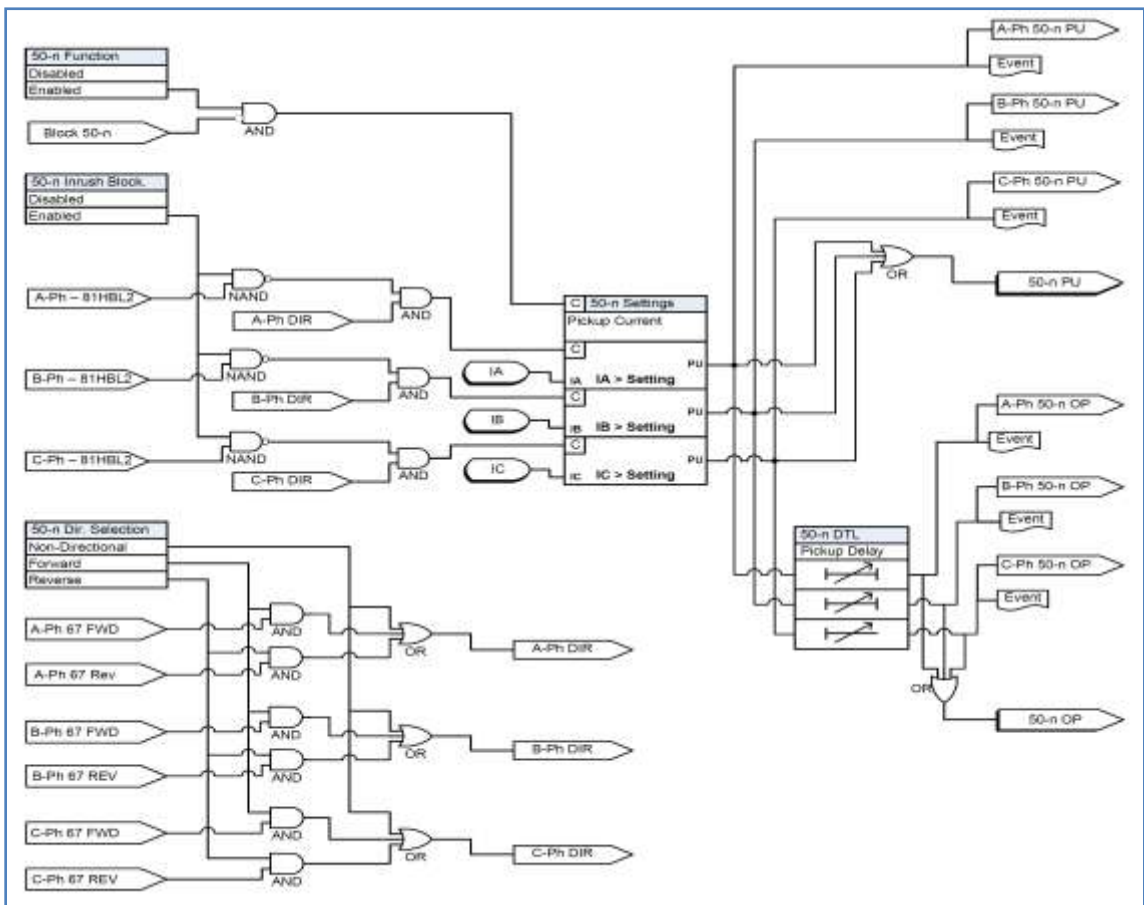

Figure 4.4: Logic Diagram of 50/67 Function

Table 4.5: 50/67 Phase Over current Settings (No. of Stages - 2)	
Setting Description	Range
50/67-1 and 50/67-2	Enable/disable
Direction Selection	Forward/ Reverse/ Non Dir
Pickup current, I	0.25 to 125.00 (5 A) / 0.05 to 25 (1 A)
Pickup DTL Delay	0.00 (0.01 if FWD/REV) to 999.99 seconds
Inrush Blocking	Enable/disable

51/67 IDMTL Phase Overcurrent

Relay co-ordination can be achieved by means of adjusting Time Multiplier Settings (TMS), current setting or a combination of both time and current. Based on the fault, the relay can be used with current grading. If fault current is approximately constant then time grading can be used. For grid connected stations combination of both is used. When Z_{source} (the impedance between the relay and the power source) is small compared to that of the protected section Z_L , there is an appreciable difference between the current for a fault at the far end of the section ($E_{source} / (Z_{source} + Z_{line})$), and the current for a fault at the near end (E_{source} / Z_{source}). When operating time is inversely proportional to the current, the relay operates faster for a fault nearer the power source, and the operating time is more for a fault at far end. Grading by time is used in rare cases since it can often lead to excessive fault clearance time at substations where the fault level is high. For these reasons the most commonly applied characteristic in coordinating Overcurrent relays is the IDMTL type.

Each function has independent setting for direction selection – Non Direction / Forward / Reverse. Function 51/67 provides five IEC inverse time curve types, three IEEE inverse time curve types of Overcurrent protection and one user- defined curve as well as definite time delayed protection also i.e. DTL. The equation and the parameters of Function 51/67-1 and 51/67-2 are listed in following tables. Each element (51/67-1, 51/67-2) can be independently inhibited via external input status which can be configured from input matrix. This will help in achieving comprehensive blocking schemes.

User can define the reset delay for the relay; It can be set as DTL or by ANSI delay. Setting of the timer to a value other than zero, delays the resetting of the protection element timers for this period. This may be useful in special applications especially in cable feeders. By providing the setting, fault clearance gets reduced for intermittent faults.

$$\text{Pickup: } T(I) = TMS \left[B + \frac{A}{\left(\frac{I}{I_{Pickup}} \right)^p - 1} \right] \qquad \text{Reset: } T(I) = TMS \left[\frac{TR}{1 - \left(\frac{I}{I_{Pickup}} \right)^2} \right]$$

Table 4.6: IEC and IEEE Curves					
Sl. No	Characteristic	A	B	p	TR
1	Definite Time Lag (DTL)	-	-	-	-
2	IEC Standard Inverse-3	0.14	0	0.02	13.50
3	IEC Standard Inverse-1	0.0613	0	0.02	6.00
4	IEC Very Inverse	13.5	0	1.0	47.30
5	IEC Extremely Inverse	80.0	0	2.0	80.00
6	IEC Long Time Inverse	120.0	0	1.0	120.00
7	IEEE Moderately Inverse	0.0103	0.0228	0.02	0.97
8	IEEE Very Inverse	3.9220	0.0982	2.0	4.32
9	IEEE Extremely Inverse	5.6400	0.0243	2.0	5.82
10	User-defined	0.0010 to 1000.000	0.0 to 10.0	0.01 to 100.0	0.1 to 150.0

Table 4.7: 51/67 Phase Overcurrent Settings(No. of Stages - 2)	
Setting Description	Range
51/67-1 and 51/67-2	Enable/disable
Direction Selection	Forward/ Reverse/ Non Dir
Pickup Current, I	0.25 to 50 (5 A) / 0.05 to 10 (1 A)
Curve Type	For details see "IEC and IEEE Curves" Table
TMS	0.01 to 10.00
Pickup DTL Delay	0.00 (0.01 if FWD/REV) to 999.99 seconds
Reset Delay	DTL/ANSI Decay
Reset DTL Delay	0.0 to 99.9 seconds (applicable if DTL reset is chosen)
Constant A	0.0010 to 1000.0000 (applicable only for user defined characteristics)
Constant B	0.0000 to 10.0000 (applicable only for user defined characteristics)
Constant P	0.01 to 100.00 (applicable only for user defined characteristics)
TR	0.10 to 150.00 (applicable only for user defined characteristics)
Inrush Block	Enable/disable

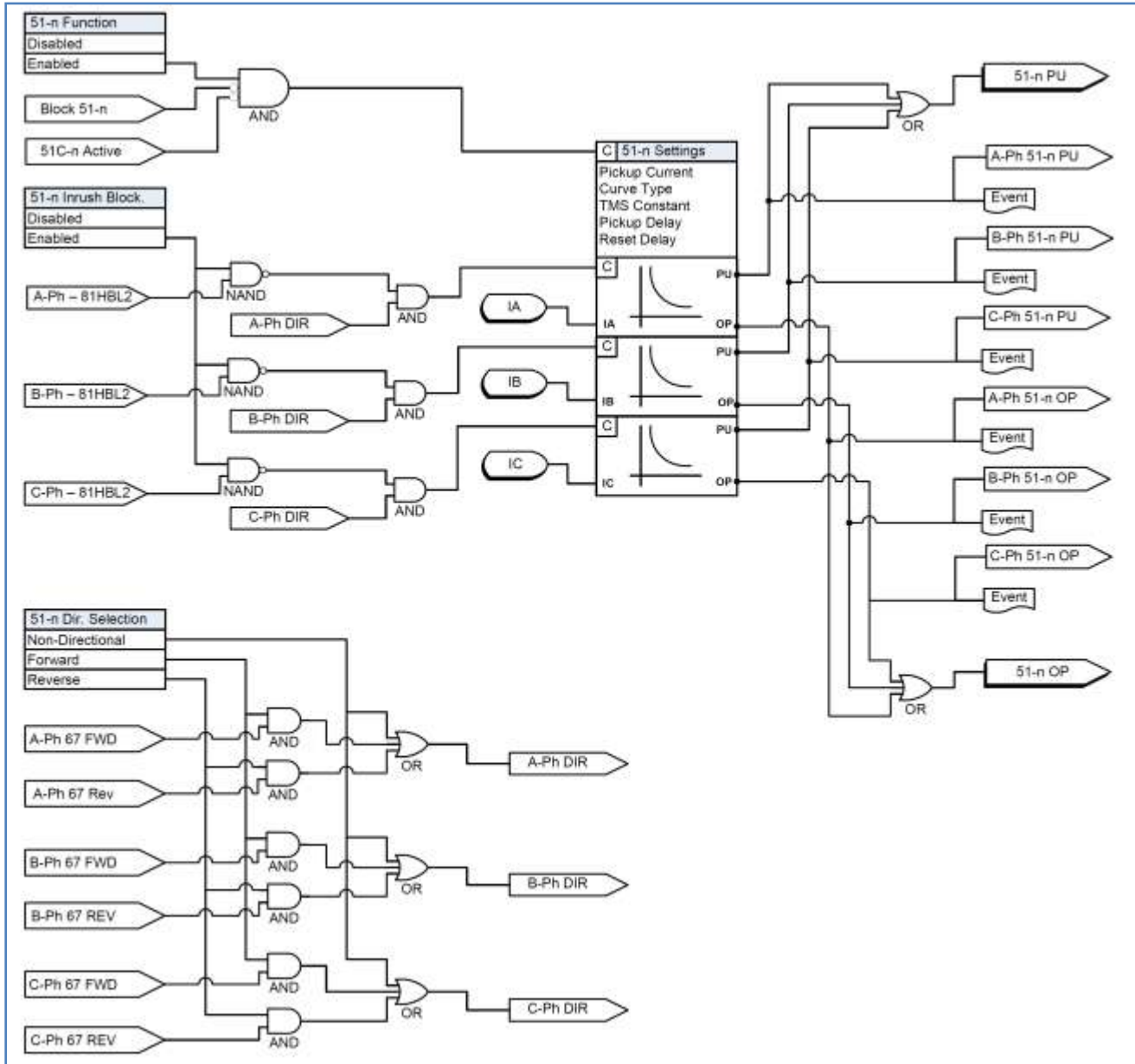

Figure 4.5: Logic Diagram of 51/67 Function

50N/67N Derived Neutral Overcurrent

Neutral Overcurrent provides protection for line-to-ground faults. Derived neutral Overcurrent (50N/67N) provides instantaneous and definite time lag protection to the equipment. Relay internally summates all the three phase currents and calculates $3I_0$ current flowing in the neutral the function operates on the derived neutral current. User can define the Current and time setting for the function operation. This function has two stages 50N/67N-1 and 50N/67N-2 both can be set independently based on the requirement of the user, i.e. instantaneous or definite time

Derived neutral current is compared with the set value of current after filtering. If calculated current is greater than the set current with the function enabled relay will go for the operation after the set time delay. Relay is provided with the additional feature of “Inrush Blocking”. This is the provided to block the function from operation when second harmonic current is present over the fundamental.

Each element (50N/67N-1, 50N/67N-2) can be independently inhibited via external input status which can be configured from input matrix. This will help in achieving comprehensive blocking schemes.

Metering menu provides the current and voltage values and their phase angles. The rightness of the polarity of directional over current element is to be verified in metering.

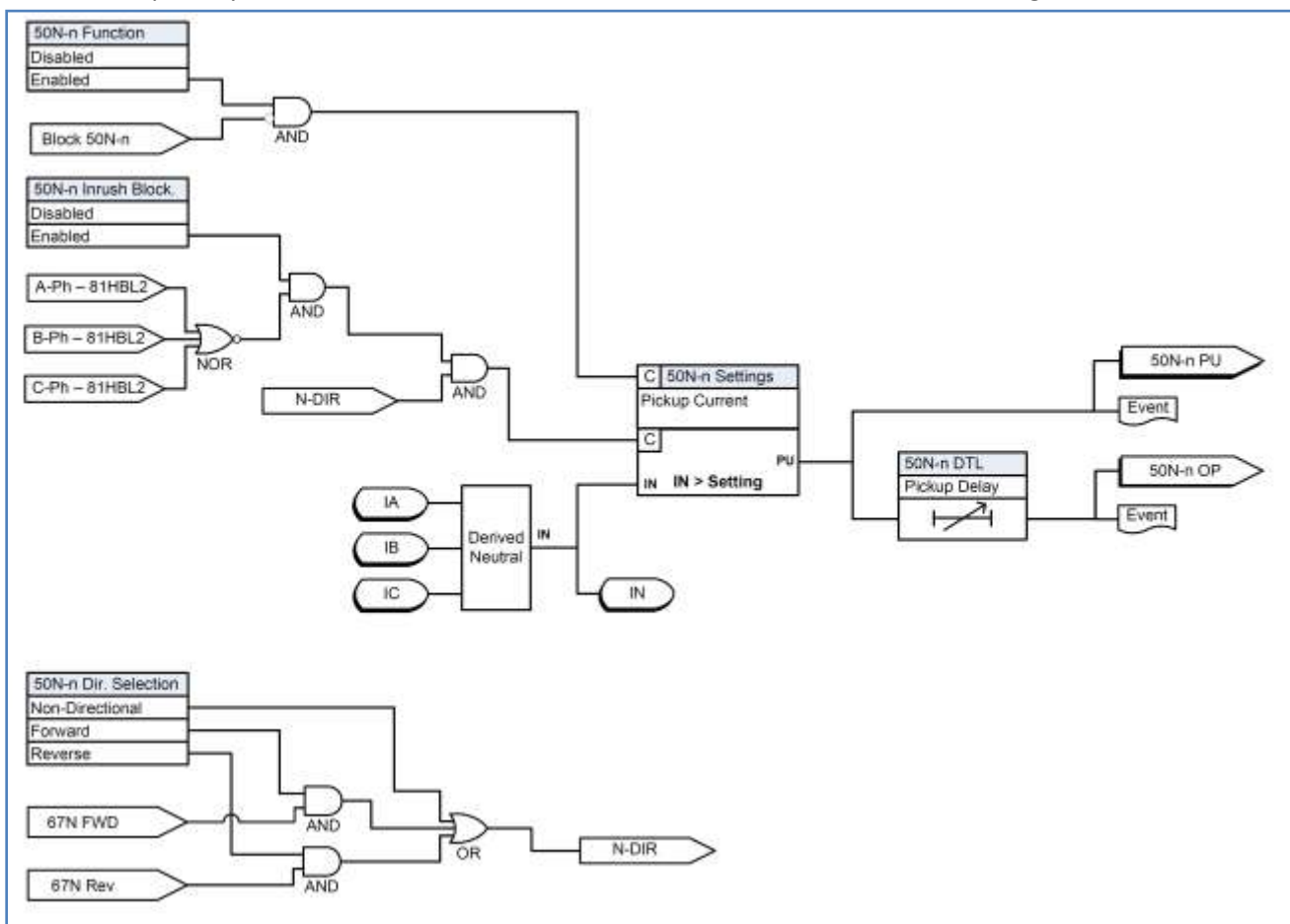

Figure 4.6: Logic Diagram of 50N/67N Function

Table 4.8: 50N/67N Derived Neutral Overcurrent Settings(No. of Stages - 2)	
Setting Description	Range
50N/67N-1 and 50N/67N-2	Enable/disable
Directional Selection	Non Dir/ FWD/ REV
Pickup I_N	0.25 to 125 (5 A) / 0.05 to 25 (1 A)
Pickup DTL Delay	0.00 (0.01 if FWD/REV 0.01) to 999.99 seconds
Inrush Block	Enable/disable
Inrush Block	Enable/disable

51N/67N IDMTL Derived Neutral Overcurrent

Neutral Overcurrent provides protection for line-to-ground faults. All the curve definitions are the same as the phase Overcurrent except that this function uses $3I_0$ rather than phase current. The equation is:

$$\text{Pickup: } T(I) = TMS \left[B + \frac{A}{\left(\frac{I_N}{I_{N \text{ Pickup}}} \right)^p - 1} \right] \quad \text{Reset: } T(I) = TMS \left[\frac{TR}{1 - \left(\frac{I_N}{I_{N \text{ Pickup}}} \right)^2} \right]$$

The Curve Type selection allows user to use a number of curves available in this menu. All of these curve types are generated by the equation as shown. If user-selectable curve is chosen, it can be created using the parameters A, B and p.

For 46-51 (IDMTL), the curve definitions are same as for Phase Overcurrent 51(IDMTL), except in case of Standard Inverse wherein only Standard Inverse 3 is used. In the characteristic of the Overcurrent function can be rescaled by clicking on the graph. By using the right mouse key and by making a box around the area of interest; the zoomed graph will be shown. The characteristic can be printed by pressing the Print Graph option.

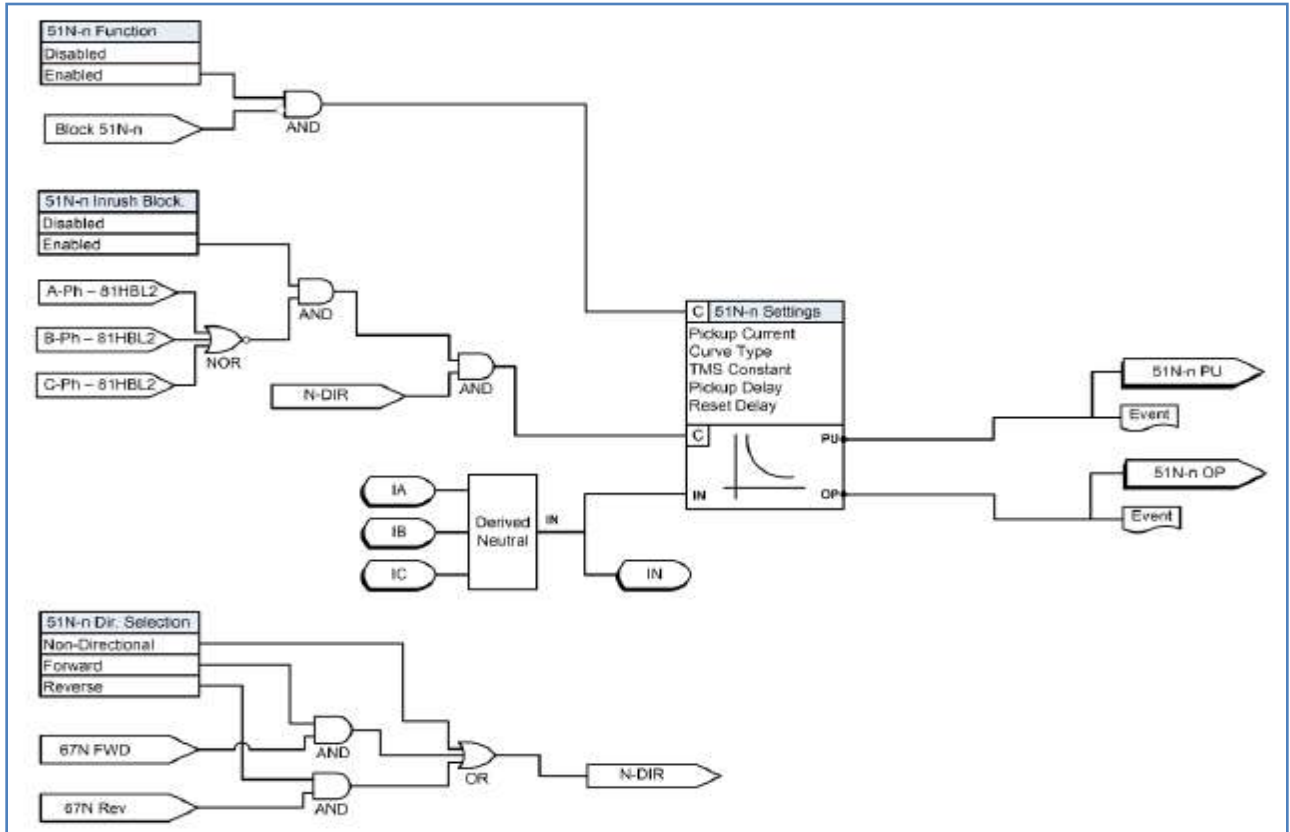

Figure 4.7: Logic Diagram of 51N/67N Function

Table 4.8: 51N/67N Derived Neutral Over current Settings (No. of Stages - 2)

Setting Description	Range
51N/67N-1 and 51N/67N-2	Enable/disable
Direction Selection	Forward/ Reverse/ Non-Dir
Pickup I_N	0.25 to 50 (5 A) / 0.05 to 10 (1 A)
Curve Type	For details see "IEC and IEEE Curves" Table
TMS	0.01 to 10.00
Pickup DTL Delay	0.00 (0.01 if FWD/REV) to 999.99 seconds
Reset Delay	DTL/ANSI Decay
Reset DTL Delay	0.0 to 99.9 seconds (applicable if DTL reset is chosen)
A	0.0010 to 1000.0000 (applicable only for user defined characteristics)
B	0.0000 to 10.0000 (applicable only for user defined characteristics)
P	0.01 to 100.00 (applicable only for user defined characteristics)
TR	0.10 to 150.00 (applicable only for user defined characteristics)
Inrush Block	Enable/disable

46-50/51 Negative Sequence Over current

Negative Sequence Overcurrent provides protection for any unbalanced loading which may occur during phase to phase faults and also in detecting asymmetrical faults with magnitude lower than the maximum load current. Function 46-50, 46-51 is similar to 50 or 51 except derived negative sequence current is utilized to drive the algorithm.

User can define the reset delay for the relay; It can be set as DTL or by ANSI delay. Setting of the timer to a value other than zero, delays the resetting of the protection element timers for this period. IDMTL equation, negative sequence current (I_2) is used instead of I .

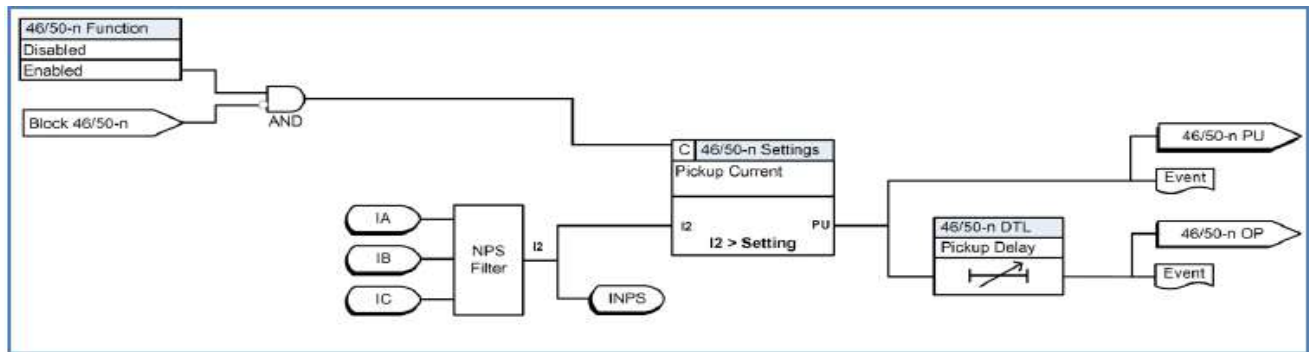

Figure 4.8: Logic Diagram of 46/50 Function

Table 4.9: 46/50 Negative Sequence Over current Settings	
Setting Description	Range
Function Activation	Enable/disable
Pickup	0.05 to 0.95 (1 A) / 0.25 to 4.75 (5 A)
Pickup Delay	0.00 to 999.99

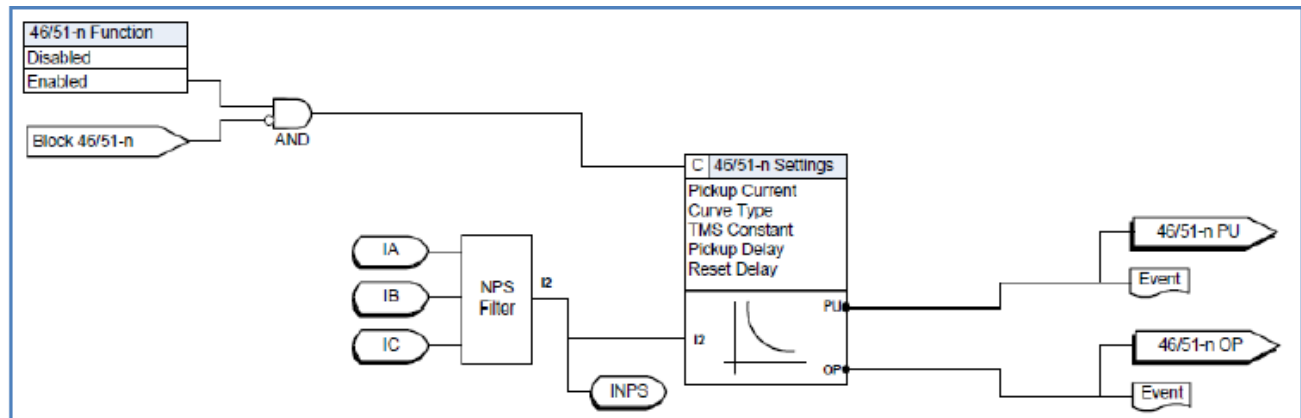

Figure 4.9: Logic Diagram of 46/51 Function

Pickup:

$$T(I) = TMS \left[B + \frac{A}{\left(\frac{I_2}{I_{2Pickup}} \right)^p - 1} \right]$$

Reset:

$$T(I) = TMS \left[\frac{TR}{1 - \left(\frac{I_2}{I_{2Pickup}} \right)^2} \right]$$

Table 4.10: 46/51 (IDMTL) Negative Sequence Overcurrent Settings

Setting Description	Range
Function Activation	Enable/Disable
Pickup	0.05 to 0.95 (1 A) / 0.25 to 4.75 (5 A)
Curve Type	For details see Table “IEC and IEEE Curves”
TMS	0.01 to 10.00
Pickup DTL Delay	0.00 to 999.99 seconds if chosen for DTL characteristics
Reset Delay	DTL / ANSI Decay
Reset DTL Delay	0.0 to 99.9 seconds (applicable if DTL reset is chosen)
A	0.0010 to 1000.0000 (applicable only for user defined characteristics)
B	0.0000 to 10.0000 (applicable only for user defined characteristics)
p	0.01 to 100.00 (applicable only for user defined characteristics)
TR	0.10 to 150.00 (applicable only for user defined characteristics)

49 Thermal Overload

The insulating material surrounding the windings ages rapidly if the temperature exceeds the design limit value. Thus a thermal protection function is required to supplement the existing winding temperature device. The thermal overload protection estimates winding temperature and thus prevents it from thermal damaging. The thermal overload protection operates based on an approximate replica of the temperature rise in the protected object caused by overload. The thermal overload in the IED is provided with one trip stage as well as one alarm stage. It is possible to set the alarm stage at a certain percentage of the setting value applied at the trip stage. The calculation is performed separately for three phase based on fundamental component and negative sequence components.

The function takes single input energizing quantity for measurement. The input used for the measurement is phase current. Thermal overload is measured based on the input current applied to it. There are dedicated functions for each phase. Operate time of the thermal overload characteristics can be calculated from the following formula given below:

$$t = \tau \cdot \text{Ln} \frac{I^2 - I_P^2}{I^2 - I_B^2}$$

Where,

- t = Operating time in minutes
- τ = Thermal time constant in minutes
- Ln = Natural log
- I_P = Steady state relay current prior to overload
- I_B = Basic current
- I = Effective relay current

Basic current I_B is full load current of the protected feeder. Constant k is a multiplying factor resulting in the 49 Thermal OL setting of the relay I_θ which is equal to $k \cdot I_B$. Thermal time constant – τ for the relay can be set using 49 Time constant setting. The effective relay current I is calculated as below:

$$I = \sqrt{I_{RMS}^2 + kI_2^2}$$

Where:

- I = Effective relay current
- I_{RMS} = 3 phase RMS current
- I_2 = Negative sequence current
- K = Negative sequence weighing factor

Negative sequence weighing factor-K for the relay can be set using 49 Neg. Seq. weighing factor setting.

Thermal operating time of thermal OL function is based on prior load current to the relay. If $I_P < 0.02I_B$ prior to thermal OL condition, then it is treated as cold condition, hence it adopts cold curve. If I_P is greater than zero prior to thermal OL condition, then it is treated as hot condition, hence it adopts hot curve.

Thermal state (θ) for the heating curve is calculated as below:

$$\theta = \frac{I^2}{I_\theta^2} \cdot (1 - e^{-t/\tau}) \cdot 100\%$$

Thermal state (θ) for the cooling [or] reset curve is calculated as below:

$$\theta = \theta_F \cdot e^{-t/\tau} \text{ [or]} \quad t = \tau \cdot \ln \frac{\theta}{\theta_F}$$

Where

θ = Thermal state in percentage at time t

θ_F = Final thermal state before disconnection of feeder

I = Effective relay current.

$I\theta$ = Thermal overload setting

τ = Thermal time constant in minutes.

The final thermal state θ_F for any steady state value of input current can be predicted using the following formula.

$$\theta = I^2/I_0^2 * 100\%$$

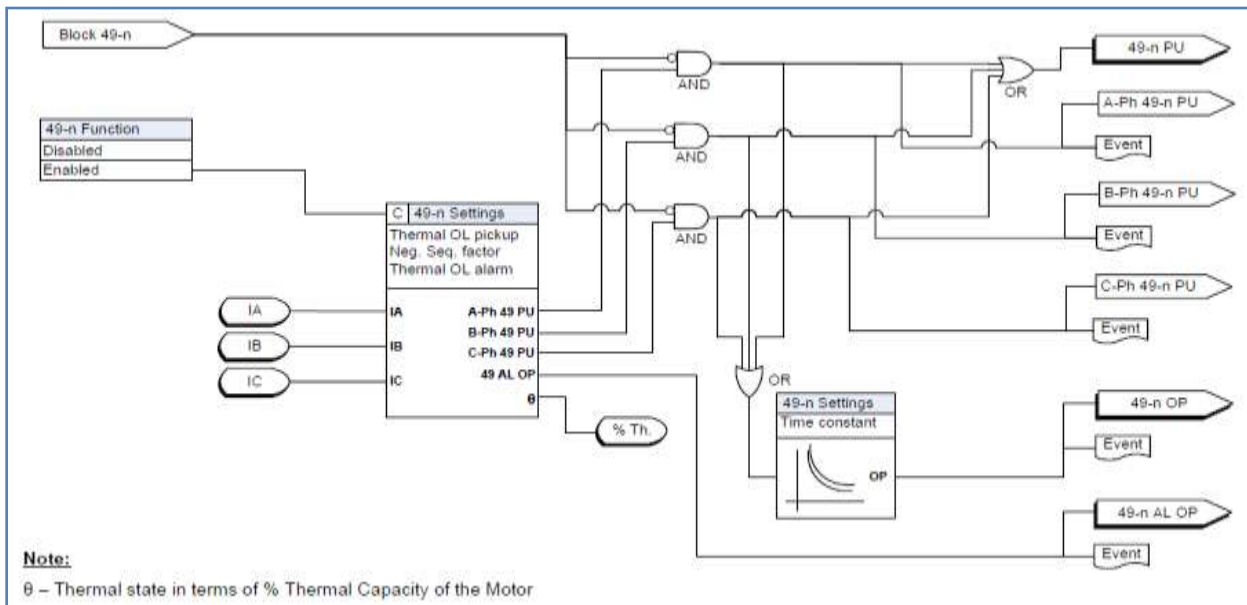

Figure 4.10: Logic Diagram of 49 Function

Table 4.11: 49 Thermal Overload Settings	
Setting Description	Range
Function Activation	Enable/disable
Thermal Overload Pick up	0.2 to 2.0A (1A) / 1.0 to 10.0 A (5A)
Time constant(τ)	0.5 to 100 Min.
Negative Sequence Weighing Factor(K)	0.0 to 10
Thermal Overload Alarm	Enable/Disable
Pickup % th	50% to 100%

50BF Breaker Failure

There are two sets of breaker failure protection functions. When breaker failure is initiated by an external trip or other internal logic (user-settable through the output matrix) and the breaker current still exists, two timers (T1 and T2 – user-settable) are started. After these timers are timed out, and if the current still exists indicating a breaker failure, the output of this function is set high. Use the two outputs of this function to trip another trip coil or the next level of breakers, such as bus breakers. The breaker failure protection logic diagram is shown below. Phase current supervision is fixed at 4% of I nominal.

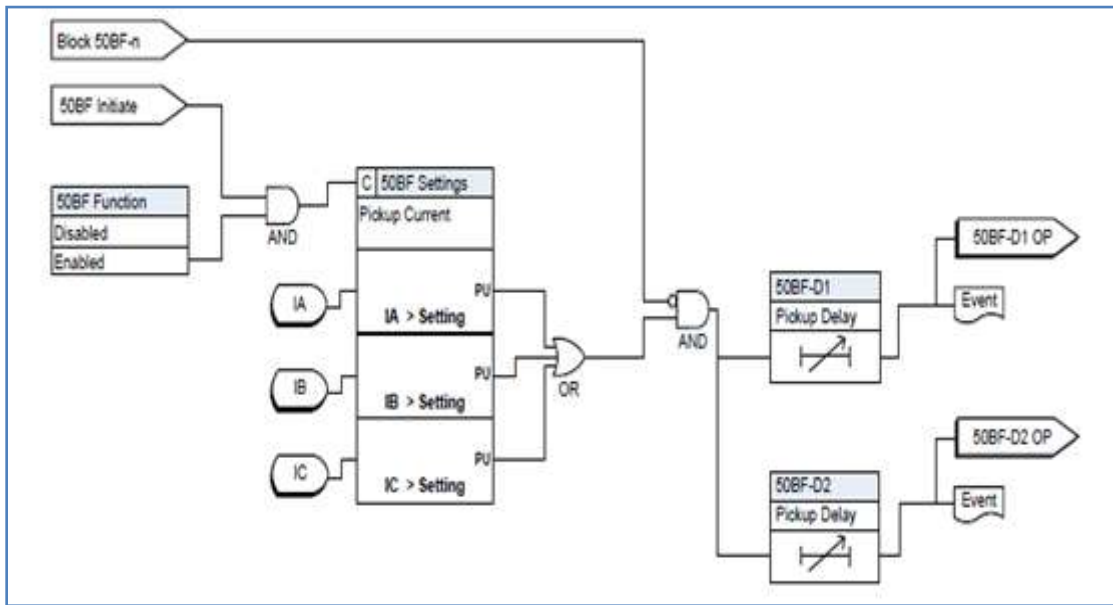

Figure 4.11: Logic Diagram of 50BF Function

Table 4.12: 50BF Breaker Failure Settings	
Setting Description	Range
Function Activation	Enable/Disable
Pick up I	0.05 to 2.0A (1A) / 0.25 to 10.0A (5A)
Pickup Delay 1	0.00 to 999.99 seconds
Pickup Delay 2	0.00 to 999.99 seconds

46BC Broken Conductor

The Broken Conductor (46BC) function can detect unbalanced series or open circuit faults (referred to as *series faults* from here on). Series faults can arise from broken conductors or jumpers, misoperation of single phase switchgear and the operation of series fuses. Series faults do not cause an increase in phase currents in the system and thus are not easily detectable by standard overcurrent relays. However, series faults produce an unbalance and a detectable level of negative sequence current.

A negative sequence overcurrent relay (46-50/46-51) could possibly be used to detect series fault conditions. However, on a lightly loaded line, the negative sequence current resulting from a series fault may be very close to, or less than, the full load steady state unbalance in the system. A negative sequence element therefore would not operate at low load levels. For this reason, the 46BC function is used to detect series faults.

The function incorporates an element which measures the ratio of negative sequence to positive phase sequence current (I_2/I_1). This ratio is affected less severely than the measurement of negative sequence current alone, since the ratio remains approximately constant with variations in load current. This ratio allows for a more sensitive setting to be achieved.

An adequate time delay should be used to coordinate with other protective devices and to ensure that the device does not trip during the operation of single phase switchgear or during re-close sequences.

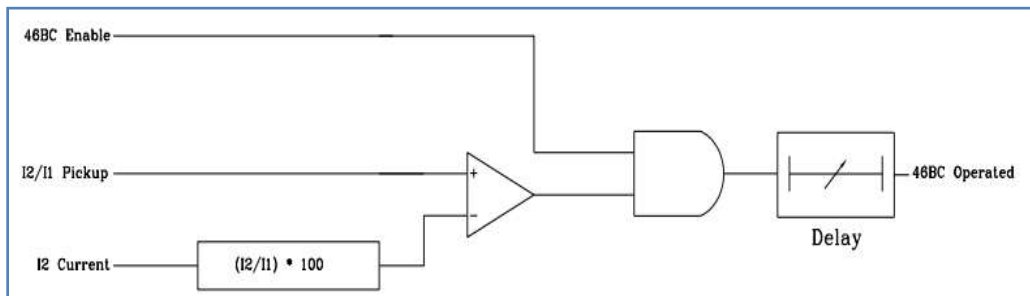

Figure 4.12: Logic Diagram of 46BC Function

Table 4.13 46BC Broken Conductor	
Setting Description	Range
Function Activation	Enable/Disable
Pickup I ₂ /I ₁	20.0% to 100.0 %
Pickup Delay	0.02 to 999.99 seconds

60CTS- CT Supervision

Current Supervision function is employed to detect failure of the current inputs to the relay. The function operates based on the condition that there will be presence of negative sequence current and the absence of negative sequence voltage. The function operates when the negative sequence current is greater than the set value and the negative sequence voltage is less than the set value. The logic diagram for the function is shown below.

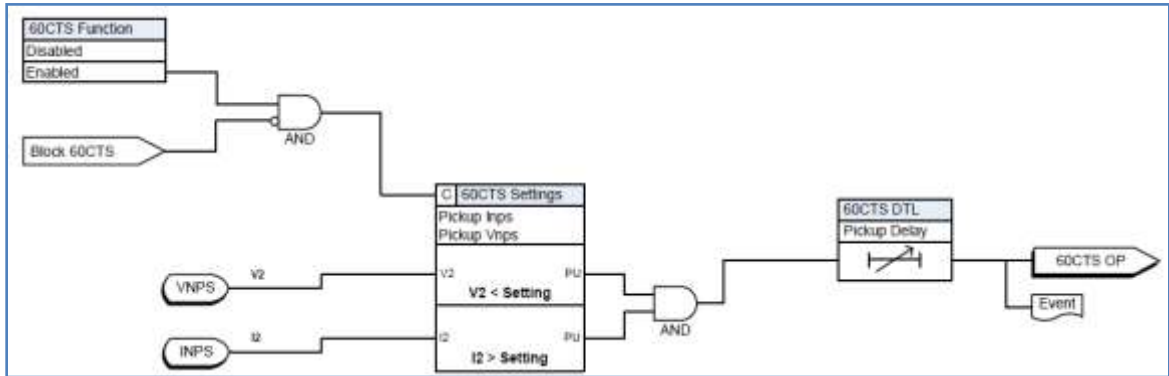

Figure 4.13: Logic Diagram of 60 CTS Function

Table 4.14: 60CTS – CT Supervision

Setting Description	Range
Function	Enable/Disable
Vnps Pickup	7.0 to 110.0 V
Inps Pickup	0.25 to 5.00 A (5A) 0.05 to 1.00 A (1A)
Pickup delay	0.03 to 999.99 seconds

60VTS – VT Supervision

Voltage Supervision function is to detect loss of one, two or even all three phases voltage inputs to relay. The voltage failure may happen due to internal faults in the voltage transformer or due to human errors such as faults in terminal wiring to relay. This causes mal-operation of directional elements and the consequence is instability of power system. Thus the VT Supervision function is incorporated in the directional relay. On detection of VT failure, the function blocks the other protection functions. The function detects VT failure on the basis that during single or two phase VT failure, there will be presence of negative sequence voltage but the negative sequence current which usually accompanies it during normal unbalance will not be present. But, during three phases VT fails, there will not be even negative sequence voltage. At that time, the function works according to the logic settings that have been loaded. If the negative and positive sequence voltage exceeds the set value, the function is blocked as it will increase on a fault only.

Operation:

Condition 1: Whenever the Injected neutral voltage (V_n) is less than the Pickup value, the function operates.

Condition 2: Whenever the Injected Phase - Phase voltage (V_{3ph}) is more than the Pickup value, the function operates.

Condition 3: Whenever there is no potential in any one of the phases, the function operates.

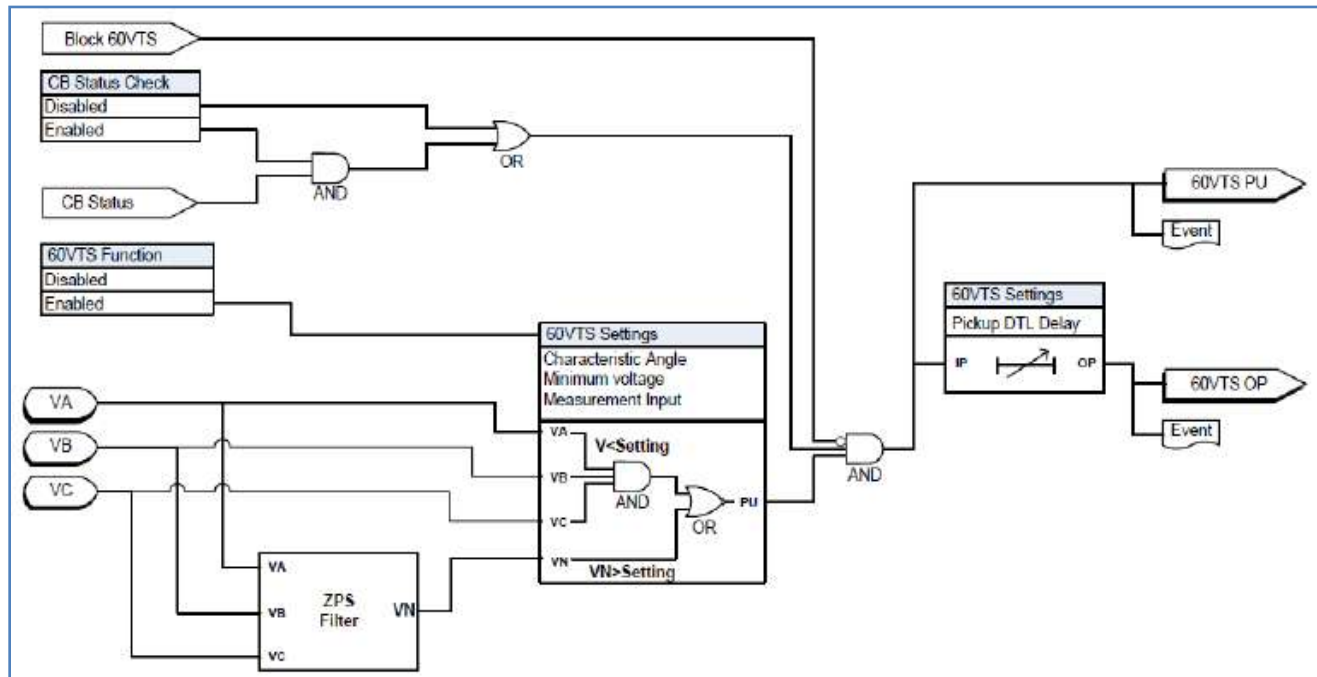

Figure 4.14: Logic Diagram of 60 VTS Function

Table 4.15: 60VTS- VT Supervision Settings	
Setting Description	Range
Function	Enable / Disable
I1 Blocking	0.1 to 10A
3I0 Blocking	0.1 to 10A
Negative Sequence Monitoring	Enable / Disable
Vnps	7.0 to 110.0 volts
Inps	0.05 to 1.00 A

74TCS Trip Circuit Supervision

74TCS function detects trip circuit failure when 74 TCS asserts and followed by the drop-off timer unit operation. The drop-off timer delay can be set using 74TCS DTL setting value. On expiry of the drop-off delay, the final operate output of the function is issued. User has to configure one of the external inputs to 74TCS for Trip Circuit Supervision purpose.

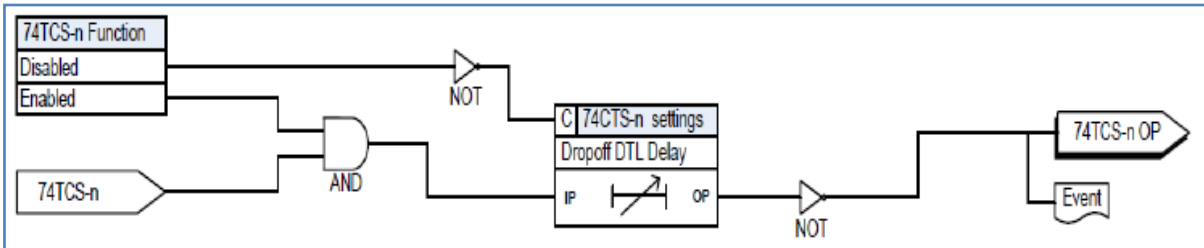

Figure 4.15: Logic Diagram of 74TCS Function

Table 4.16: 74TCS Trip Circuit Supervision (No. of Stages - 2)	
Setting Description	Range
74TCS-1	Enable/Disable
Name	TCS-1 (The name is editable up to 12 characters)
Drop Off Delay	0.00 to 9.99 seconds

81HBL2 Inrush Block

The protection relay may detect large magnetizing inrush current during transformer energizing. In addition to considerably unbalanced fundamental current, inrush current is comprised of large second harmonic current which doesn't appear in short circuit current. Therefore, the inrush current may affect the protection functions which operate based on the fundamental component of the measured current. Accordingly, inrush restraint logic is provided to prevent Overcurrent protection from mis-operation.

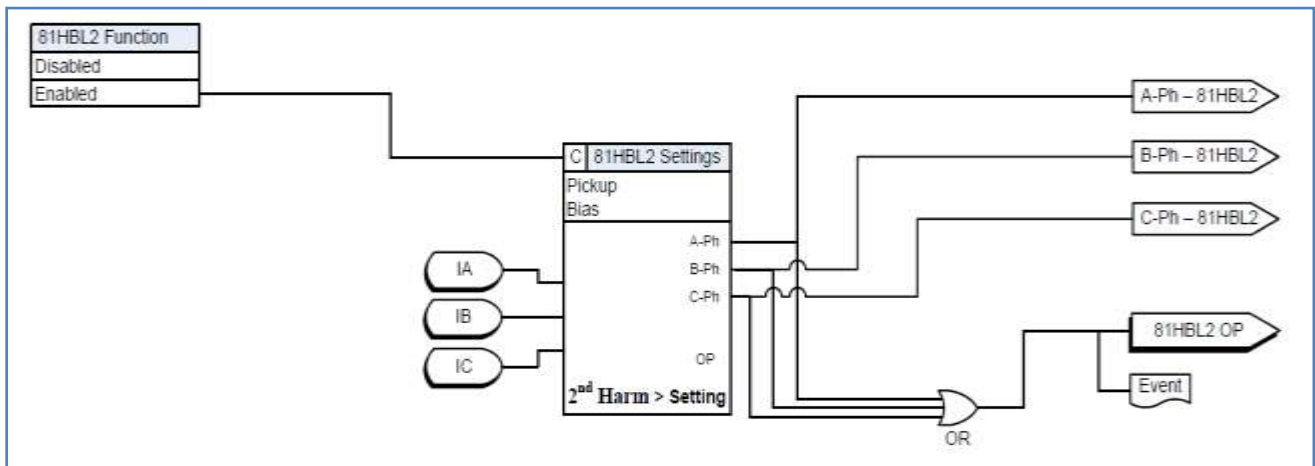

Figure 4.16: Logic Diagram of 81HBL2 Function

Table 4.17: 81HBL2 Inrush Block	
Setting Description	Range
81HBL2	Enable/Disable
Cross Blocking	Enable/Disable
Percentage of second harmonic current I2nd	5 to 50 %

79 Reclose

F-PRO includes a four shot recloser. After four reclose attempts, the recloser is locked out. The lockout is cleared once the feeder returns to normal by manual operation, meaning that the feeder has been on with a load greater than the low set setting for a certain amount of time. The 79 function initiate and block functions are defined in the output matrix.

Table 4.18: 79 Recloser	
Setting Description	Range
79 Recloser	Enable/disable
Number of Shots	1 to 4
First Reclose (T1)	0.10 to 999.99 seconds
Second Reclose (T2)	1.00 to 999.99 seconds
Third Reclose (T3)	1.00 to 999.99 seconds
Fourth Reclose (T4)	1.00 to 999.99 seconds
Close Time (Tp)	0.01 to 1.00 seconds
Reclaim Time (Td)	0.00 to 999.99 seconds
Initiate Reset (TDI)	0.00 to 999.99 seconds
Block Reset (TDB)	0.00 to 999.99 seconds

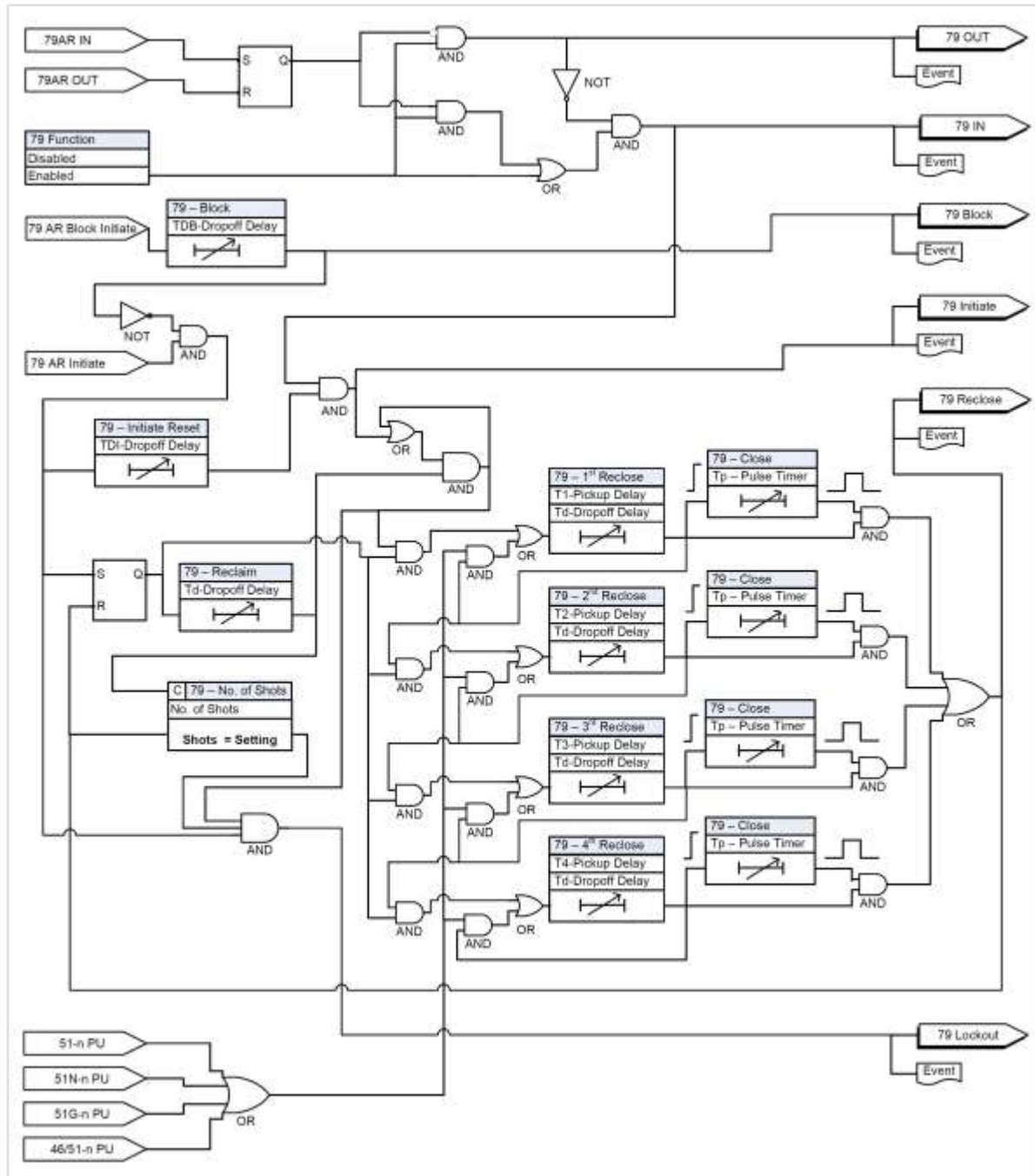

Figure 4.17: Logic Diagram of 79 Function

Breaker Monitoring

The F-PRO breaker monitoring feature allows user to monitor the feeder breaker in detail. An accumulated I^2t function can be used to determine the status of breaker wear and tear and breaker performance.

Breaker monitoring can be configured for measuring the clearing time, mechanism time, trip coil energized time, operations count, fault operations or other user-defined conditions. Different users may require different feature sets to monitor the breaker. The breaker monitoring functions are realized through the Breaker Logic functions.

All associated breaker monitoring values are available in the terminal UI and SCADA interfaces. User can reset or preset all associated breaker monitoring values from the terminal UI or SCADA interface.

I^2t

F-PRO has an accumulated I^2t function used for monitoring the wear and tear of the breaker due to fault interruption. This function is available for the breaker. The I^2t value is accumulated for every operation and stored in the non-volatile memory; the write time interval is 0.5 seconds. A fixed maximum write time of 20 seconds prevents the I^2t function from constantly writing to non-volatile memory. Therefore if the start signal is held on for longer than 20 seconds the accumulator stops accumulating and stops writing to the flash memory. The output I^2t function is only available in the event log, the output matrix or in the ProLogic input list.

The terminal UI and SCADA interfaces show the accumulated value of each breaker I^2t function and value of last operation. The terminal UI also includes the time of last reset/preset.

The following figure shows the I^2t function's logic diagram. The accumulation is started when the trip coil of the breaker is energized (breaker starts to open), and is stopped when the trip coil of the breaker is de-energized. The current that is used for accumulation is the maximum current among phase A, B and C. An event message is generated when the accumulated I^2t value is above the limit.

Table 4.19: I^2t CB	
Setting Description	Range
I^2t CB	Enable/disable
I^2t limit	0.1 to 99999.9 kA ² seconds

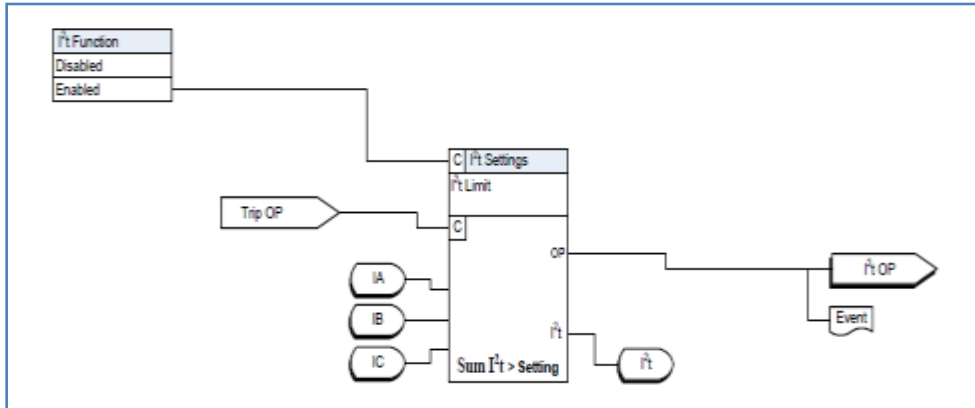

Figure 4.18: Logic Function of I²t Function

ProLogic

ProLogic is used to create an output based on qualified multiple inputs. 20 User Programmable ProLogic control statements can be utilized to create custom logic which may be mapped to output contacts.

User can define or name the function being created and set a pickup and dropout delay. Each ProLogic statement can be used with internal relay functions and external inputs (up to 5 possible inputs) to create the logic output by using Boolean logics such as AND, OR, NAND, NOR, EX-OR, EX-NOR and LATCH.

The output of ProLogic 1 can be nested into ProLogic 2 and so on. If desired, user can illuminate the front target LED on operation of this function by enabling this feature in the LED Output Matrix.. The operations of the ProLogic statements are logged on the events listing. The status of the ProLogic can be seen from the record graph by selecting the recorder in the output matrix.

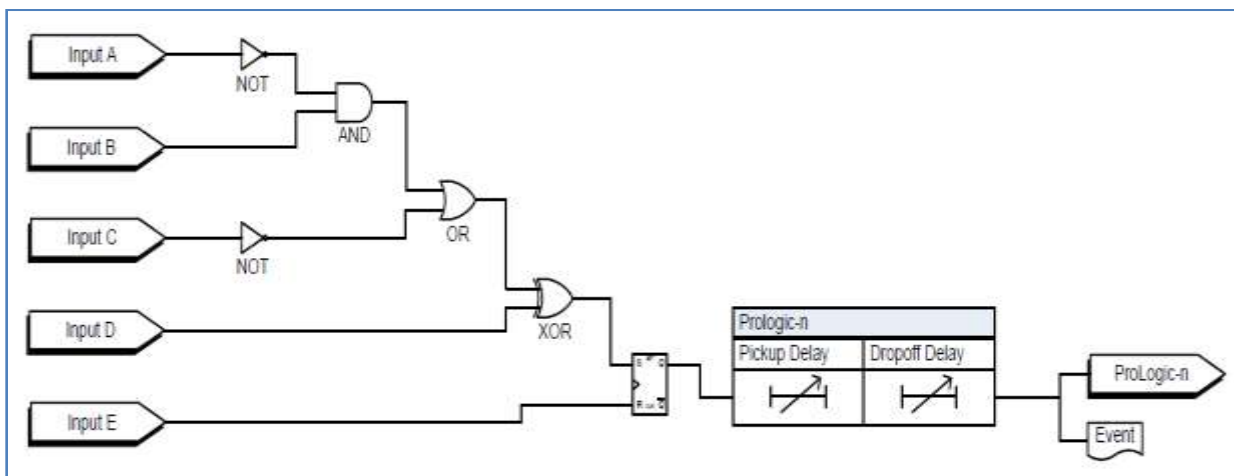

Figure 4.19: ProLogic Function

Table 4.20: ProLogic Setting	
Name	ProLogic (The name is editable up to 12 characters)
Pickup Delay	0.00 to 999.00 seconds
Dropout Delay	0.00 to 999.00 seconds
A, B, C, D, E	Relay elements as input statements
Operators	Boolean-type logic gates

Group Change Control Statement

The F-PRO235 relay has Four setting groups (SG1 to SG4). The user can change all relay setting parameters except the physical connections such as input, in each setting group. Setting group changes can also be performed by using any one of the 4 available Digital Inputs per setting group or through Relay Control Panel or through relay display interface. The Group change inputs are similar to the LED and output. The processing for activating the setting group is half a second. During the transition of one setting group to another setting group, the previous setting group will still be operational. The active setting group (ASG) is viewed using the Relay Control Panel, the front panel or from a record stored by the relay (the active setting group is stored within the record).

Active Setting Group

The relay uses Setting Group 1 as the factory default setting group and retains the current active setting group in memory. This allows the relay to use the last active setting group prior to interruption of relay power as the default setting group following power up.

Default Setting

The user can at any time change the active setting group. When user initiate a setting group change, this change takes precedence over an automatic setting group change.

The setting group can be changed using the Relay Control Panel, with either Change or Service access level, using the following path:

Relay Control Panel > Utilities > Settings Group

In this tab, choose desired setting group number and

Click *Save*.

Group Change Through RCP

The setting group can also be changed using the relay display interface, after login in with the Change or Service access level, using the following path:

Main Menu > Configuration > Setting Group > Active

Group Change Through LCD

In this screen, hit Enter and choose the desired setting group number using Up and Down keys, and then click Enter.

Setting Group Change During Setting Load

The user can change the active setting group while loading settings from Offliner using Relay Control Panel. Relay Control Panel prompts the user for a setting group to active while loading the setting. The same setting group may be used or the user may switch to a different setting group.

Manual Settings Change

Relay configuration changes during a user-initiated manual setting; the change does not disrupt the relay protection functions. The relay logs an acceptance of the change request and puts the new setting file in service. When the new setting file is queued the relay loads the new setting configuration for protection functions to the protection processor. The relay loads the new name definitions for the supplementary settings (includes channel names, ProLogic names, Group Logic statement names, front panel target LED activation rules and record initiation rules) to the interface processor. When the setting load is completed, an event is logged to show the completion of the request. There is a delay (approximately five seconds) between the load request and the completion of the request where the new supplementary settings may be temporarily applied to the previous setting file.

The Protection processor does not have any interruption in service.

Automatic Settings Change

The relay configuration changes during a relay-initiated setting change, but the protection function operations are not disrupted. Since the relay setting file does not change, the interface processor uses the new setting group supplementary setting information at the same time as the protection processor switches to the new setting group. An event is logged to show when the new setting group is in service.

4.2 Recording Functions

Introduction

The relay has high speed fault recording and logging functions to allow the user to analyze faults and to review the operation of the overall protection scheme. Event recordings provides storage for the event log. If the relay has reached its recording capacity, new records overwrite the oldest records.

Fault Recording

F-PRO provides DFR-quality fault recording, capturing input signal waveforms and external digital input states at a rate of 32 samples per cycle. Each record also contains the timing of the internal logic picked up by the relay (e.g. 51 trip). Obtain this information by uploading the records from the relay via the Relay Control Panel file transfer process and view them with RecordGraph software.

The quantities recorded are:

- 6 analog channels: 3 Phase voltage and 3 Phase current.
- Voltages and current at 32 samples/cycle
- External digital inputs at 1msec resolution
- Relay Output internal logic signals at 8 samples/cycle
- Summation channel at 32 samples/cycle
- 30 Virtual Inputs at 8 samples/cycle
- 20 ProLogic signals at 8 samples/cycle
- Active setting group

Record Initiation

Recording can be initiated automatically by the relay when a fault or abnormal condition is detected. A user can set the relay to initiate a fault record upon activation of any of its trip or alarm functions or on assertion of any external inputs.

The assignment of fault record initiation to the various relay functions is done through the relay's Output Matrix settings.

Recording can also be initiated manually through the Relay Control Panel interface in the *Records* tab and the command is *Trigger Event*.

Record Duration and Extension

The length of each record is determined by the Record Length setting. Fault record lengths can be set between 1 and 20 seconds. Pre-trigger times can be settable from 0.1 to 0.5 seconds for fault records and are included as part of the normal record length.

F-PRO relay automatically extends a record as required to capture consecutive triggers that are close together. If a trigger occurs while a recording is in progress, the record is stretched to include the full post-trigger time of subsequent triggers, up to a maximum length 20 seconds for fault records. If a trigger occurs before the end of a record caused by a previous trigger, but too late to allow sufficient post-trigger time in a maximum extended record, for which new over-lapping record is created.

The normal record lengths settings can be set from either the HMI or the Offliner Settings software and accessible in Menu below.

Configuration>Disturbance record setting >Record Length

Event Recording

The event recording provides permanent storage of the event logs. An event record can be created automatically or manually.

Record Storage

The F-PRO compresses records on the fly, achieving a typical lossless compression rate of 4:1. As a result, the F-PRO can store up to 400 seconds of fault recordings in non-volatile storage. If the storage is full, new records automatically overwrite the oldest, ensuring that the recording function is always available.

Retrieval Analysis

List of stored records is available through the Relay Control Panel in the *Records* tab. From Relay Control Panel user can retrieve the record and delete or leave on the relay, graph the record, export the record to COMTRADE / PTI & CSV formats. Records are named by combining the Unit ID setting with the date and time of the initiating record trigger.

To delete a record from storage, right-click on the record and select Delete. Alternatively, select the record and press the key. User can also do group deleting and group transferring. To select multiple records:

1. Select a record
2. Hold the <Shift> key.
3. Continue selecting records until all desired records are selected.
4. Press the key. A message asks "Are user sure user want to delete multiple records from the relay?" shown above. Select *Delete* and the files are deleted.

When a record is retrieved from the relay using Relay Control Panel program, it is automatically transferred to user PC as well. The record is placed in user Relay Control Panel program's *Recordings folder*. The Relay Control Panel's default *Recordings folder* can be set when the relay is initially connected to the PC, as shown in the following image.

The image shows a 'Relay Definition' dialog box with several sections:

- Relay Definition:** Relay Name: Relay235, Comments: comments, Location: location, Serial Number: FPRO-235-XX0000, Model: F-PRO 235, 4, A, 3.
- Communication:** Network Link (selected), IP Address (Port COM 3): 192 . 168 . 100 . 80, Use SOCKS Proxy (unchecked), Server IP: . . ., Port Number: 0, Modem Link (unchecked), Phone Number: , Modem: COM3: HDA CX11270 Soft Modem (highlighted with a red box), Direct Serial Link (selected), Serial Link: COM1: ERLPhase Null Modem, Baud Rate: 115200.
- Folder placement:** Recordings Folder: C:\Users\TPD-GOB\Documents\ERLPhase\Relay Control, Configs Folder: C:\Users\TPD-GOB\Documents\ERLPhase\Relay Control.

Buttons: Add New Modem/Serial Link, Get Information From Relay, Save Relay, Cancel.

Figure 4.20: Recording Folder Location

When transferred to user computer, the record name remains unchanged and the file extension indicates the record type:

1. **.fpr** for transient recording,
2. **.fpe** for an event recording.

4.3 Logging Functions

Event Log The F-PRO maintains a log of events in a 1000 entry circular log. Each entry contains the time Logged events include trips, alarms, external input assertions plus internal events such as setting changes. Fault information and classification information is included in event messages where appropriate. For example, the event log entry for a function trip might be:

2019 MAR 21, 15:34:19.832: 51/67-1 ABC Operated.

The event log can be viewed in three ways:

- Relay Front HMI
- Relay Control Panel interface is in the Events tab
- SCADA protocols included in the F-PRO allow the SCADA master access to Trip and Alarm event data.

Events that occur during a transient fault recording are also embedded in the transient record and can be viewed in *Relay Control Panel*, *Record Base View* and *Record Graph*. Although the event log is circular, user may ensure events are not lost by checking the manual trigger option on the records menu in Relay Control Panel. When this option is selected, as the event log is required by user, it will save the records to an event file .fpe. The event log will then be ready to capture up to 1000 new events.

This display is a snapshot of the event list which must be manually refreshed to display new events that occur while the display is up.

There is a list of the F-PRO event messages. For details see “Event Messages” in [Appendix D](#).

Fault Log The F-PRO stores a log of faults in a 20 entry circular log. Each entry contains the time of the fault, fault type, faulted phase, fault quantities as per the below table. Fault log will be triggered only for trip condition and it won't log for an alarm condition.

Table 4.21: Fault Log	
Fault Type	Fault Quantities
27DT Under Voltage	- VA / VB / VC / VN Phasors
27IT Inverse time Under Voltage	- VA / VB / VC / VN Phasors
59DT Over Voltage	- VA / VB / VC / VN Phasors
59IT Inverse Time Over Voltage	- VA / VB / VC / VN Phasors
50/67-1	- Main VA/ VB/ VC/ VN/ IA/ IB/ IC/ IN Phasors
50/67-2	- Main VA/ VB/ VC/ VN/ IA/ IB/ IC/ IN Phasors
51/67-1	- Main VA/ VB/ VC/ VN/ IA/ IB/ IC/ IN Phasors
51/67-2	- Main VA/ VB/ VC/ VN/ IA/ IB/ IC/ IN Phasors
50/67N-1	- Main VA/ VB/ VC/ VN/ IA/ IB/ IC/ IN Phasors
50/67N-2	- Main VA/ VB/ VC/ VN/ IA/ IB/ IC/ IN Phasors
51/67N-1	- Main VA/ VB/ VC/ VN/ IA/ IB/ IC/ IN Phasors
51/67N-2	- Main VA/ VB/ VC/ VN/ IA/ IB/ IC/ IN Phasors
46/50	- Main IA/ IB/ IC/ I2 Phasors
46/51	- Main IA/ IB/ IC/ I2 Phasors
49	- Phase Indication (digital indication of A/B/C phases) - Main IA/ IB/ IC/ IN Phasors
50BF-1	- Phase Indication (digital indication of A/B/C phases) - Main IA/ IB/ IC/ IN Phasors
50BF-2	- Phase Indication (digital indication of A/B/C phases) - Main IA/ IB/ IC/ IN Phasors
46 BC	-Main IA/ IB/ IC/ I2/ I1 Phasors

The fault log can be viewed in three ways:

- Relay Front HMI
- Relay Control Panel interface is in the Events tab
- IEC61850 SCADA protocol included in the F-PRO allows the SCADA client access to Trip event data.

5 Data Communications

5.1 Introduction

This topic deals with data communications with the relay. First, the SCADA protocol is discussed, and it is then followed by the new IEC 61850 communication standard.

The SCADA protocol deals with the Modbus, IEC 60870-5-103 and DNP3 protocols. The SCADA configuration and settings are described. The parameters for SCADA communications are defined using F-PRO Offliner software. Finally, the details on how to monitor SCADA communication signals are given for maintenance and troubleshooting of the relay.

5.2 SCADA Protocol

Modbus Protocol

The relay supports either a Modbus RTU or Modbus ASCII SCADA connection. Modbus is available exclusively via a direct serial link. Serial Modbus communications can be utilized exclusively via serial COM 2 (RS485 port), which is located on the rear of the relay. An external RS-485 to RS-232 converter is required to connect the relay to an RS-232 port of PC. For details on connecting to serial Port, see [“Communicating with IED”](#) and [“Communication Port Details”](#).

Complete details regarding the Modbus protocol emulation and data point lists can be found in “Modbus RTU Communication Protocol” in [Appendix E](#) on [page Appendix E-1](#)

IEC 103 Protocol

The relay supports IEC 60870-5-103 SCADA connection. IEC 103 is available via a RS485 serial link.

Serial IEC 103 communications can be utilized exclusively via serial COM 2. The RS485 port is located on the rear of the relay. An external RS-485 to RS-232 converter can be used to connect the relay to an RS-232 network. For details on connecting to serial Port, see [“Communicating with IED”](#) and [“Communication Port Details”](#).

Complete details regarding the IEC 103 protocol emulation and data point lists can be found in “Event Messages” in [Appendix D](#).

DNP3 Protocol

The relay supports a DNP3 (Level 2) SCADA connection. DNP3 is available via a direct serial link or an Ethernet LAN connection using either TCP or UDP.

Serial DNP communications can be utilized exclusively via serial COM 2. COM 2 is an RS485 port located on the rear of the relay. For details on connecting to serial Port, see [“Communicating with the Relay Intelligent Electronic Device \(IED\)”](#) on page 2-2 and [“Communication Port Details”](#) on page 2-10.

Network DNP communications can be utilized via physical LAN COM 3.

COM 3 is available as an RJ-45 or ST fiber optic port on the rear. COM 3 located on the rear of the relay is available as an RJ-45 or ST fiber optic port. DNP communications can be used with multiple masters when it is utilized with TCP. For details on connecting to the Ethernet LAN, see “[Network Link](#)” on page 2-7.

The data points available for DNP SCADA interface are user configurable. Complete details regarding the DNP3 protocol emulation and data point lists can be found in “[DNP3.0 Device Profile](#)” in [Appendix G](#).

Offliner SCADA Configuration

Details on using the Offliner software are available in “*To Install Software on the Computer*” on page -viii. Details on downloading a completed settings file to the relay are available in “*Sending a New Setting File to the Relay*” on page 6-7.

Open the Offliner application according to the instructions found in the indicated section and highlight the SCADA Communication selection. The screen appears as follows.



Figure 5.1: SCADA Communications

There is no field to configure the number of data and stop bits. These values are fixed as follows:

- Modbus Serial – 7 data bits, 1 stop bit
- IEC 60870-5-103 Serial – 8 data bits, 1 stop bit
- DNP3 Serial – 8 data bits, 1 stop bit

5.3 IEC 61850 Communication

The IEC 61850 Standard

The Smart Grid is transforming the electrical power industry by using digital technology to deliver electricity in a more intelligent, efficient and controlled way. Embedded control and communication devices are central to this transformation by adding intelligent automation to the electrical networks.

The IEC 61850 standard defines a new method that permits substation equipment to communicate with each other. Like many other well-known manufacturers, ERL also dedicated for using IEC 61850 - based devices that can be used as part of an open and versatile communications network for substation automation.

The IEC 61850 defines an Ethernet-based protocol used in substations for data communication. Substations implement a number of devices for protection, measurement, detection, alarms, and monitoring. System implementation is often slowed down by the fact that the devices produced by different manufacturers are incompatible, since they do not support the same communication protocols. The problems associated with this incompatibility are quite serious, and result in increased costs for protocol integration and system maintenance.

Implementation Details

The F-PRO conforms to IEC 61850-8-1, commonly referred as Station Bus Protocol. Implementation includes the following documents “IEC 61850 Implementation” in [Appendix N](#) on page [Appendix N-1](#):

- Protocol Implementation Conformance Statement (PICS)
- Model Implementation Conformance Statement (MICS)
- Data Mapping Specifications

Note that unit’s IP address can be used on the IEC61850 client side for unique unit identification instead of a physical device “PD Name”. The publisher configuration is fixed and defined in the ICD file and available for reading to any IEC61850 client. Subscriber functionality is also fixed and supported for the Virtual Inputs only. The IEC 61850 parameters are edited by using the ERL 61850 IED Configurator. For more details on the ERL 61850 IED configurator, see “ERL IED Configurator” on the page 6-22.

6 Settings and Analysis Software

6.1 Introduction

This section describes the supporting software used to set the relay parameters and to analyze records. There are three main software tools used for these purposes:

F-PRO Offliner Setting Software, RecordGraph and ERL 61850 IED Configurator. The F-PRO Offliner software will be described at length, while the RecordGraph and ERL 61850 IED Configurator tools will be briefly introduced.

F-PRO Offliner is used to configure all of the protection and system parameter variables on the IED. Setting files are created locally on a personal computer with the Offliner software and then are sent to the IED through Relay Control Panel ([see "Relay Control Panel" on page 3-18](#)) via a communication link ([see "Communicating with the Relay Intelligent Electronic Device \(IED\)" on page 2-4](#)).

RecordGraph is a powerful record analysis tool used to analyze both high speed Fault Recordings and low-speed Swing Recordings. RecordGraph provides many useful tools including fault impedance plotting and harmonic analysis.

The ERL 61850 IED Configurator is used to configure ERLPhase IEC 61850 based devices for substation automation. This tool helps the user to map data from remote GOOSE into ERL IED data, to perform GOOSE mapping from ERL IEDs to other devices and to map the required RCB (Report Control Block) datasets for SCADA.

6.2 Offliner Setting Software Introduction

F-PRO Offliner is used to configure all of the protection and system parameter variables on the IED. The following section provides a full breakdown of the user interface and all of the features available within the software.

More detailed information about relay settings and protection functions are provided in Chapter 4.

This is followed by a lengthy description of the main branches from the Tree View. This section provides all information for Identification, System Parameters, SCADA Communication, IEC 103 Configuration, SCADA Settings summary, Record Length, Setting Groups, ProLogic, Breaker Logic, LED Matrix, Output Matrix, reset type for Led and output contact and Settings summary.

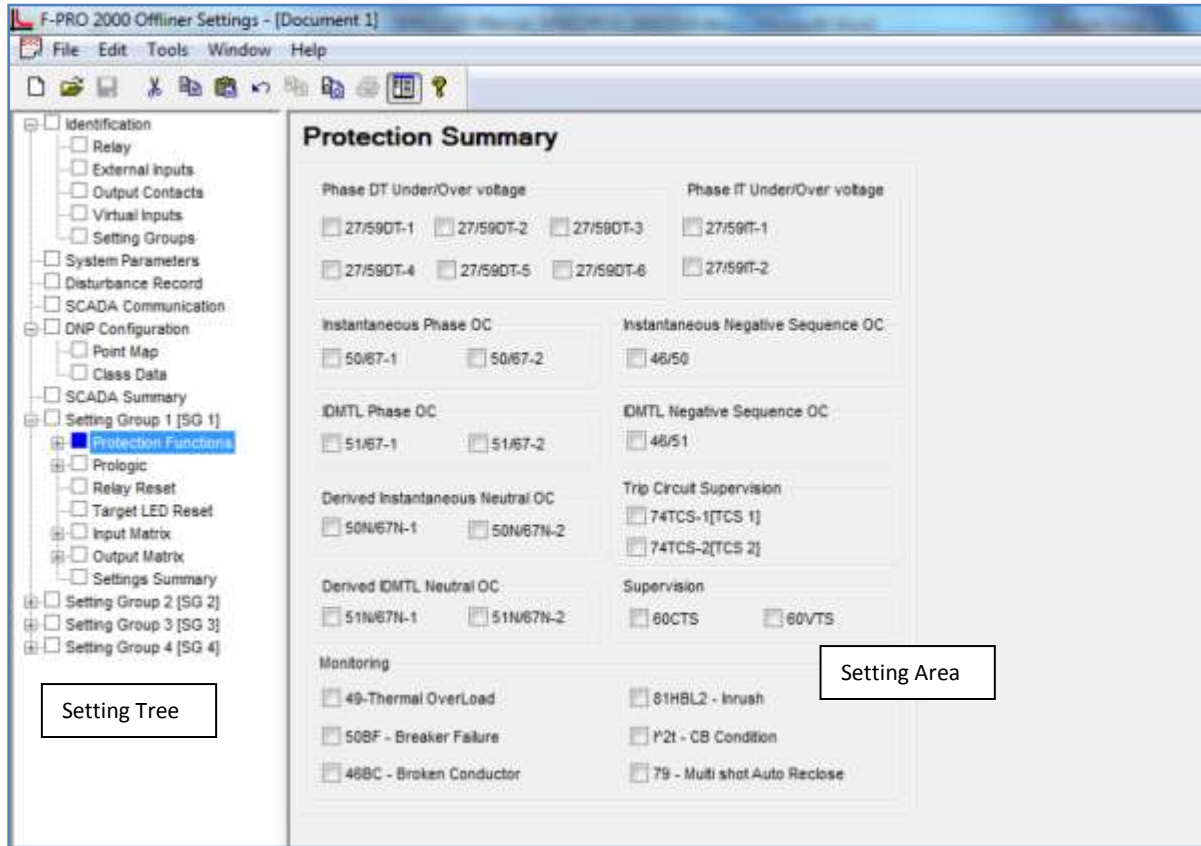

Figure 6.1: Protection Summary

6.3 Offliner Features

The Offliner software includes the following menu and system tool bar.

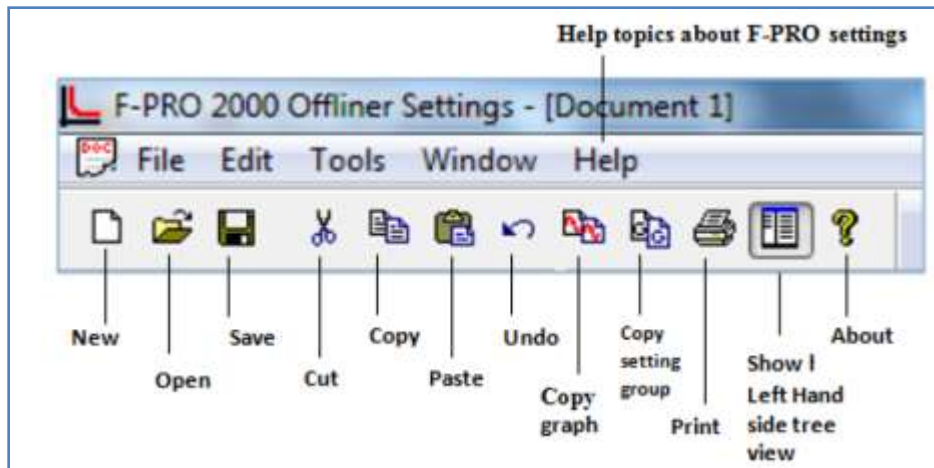

Figure 6.2: Offliner Features

Table 6.1: Windows Menu		
Windows Menu	Sub Menu	Comment
Document Menu (Icon)	Restore	Restores active window to previous size
	Move	Allows user to move active window
	Size	Allows user to resize active window
	Minimize	Makes the active window as small as possible
	Maximize	Makes the active window as large as possible
	Close	Closes the active Offliner setting document
	Next	Switches to the next open Offliner setting file, if more than setting file is being edited.
File	New	Opens up a default setting file of the most recent setting version
	Open	Open an existing setting file
	Close	Closes the active Offliner setting document
	Save	Saves the active setting file
	Save As	Saves the active setting file with a new name or to a new location
	Print	Prints graphs or setting summary depending on active screen
	Print Preview	Provides a print preview of the setting summary
	Print Setup	Changes printers or print options
	1 – 8	The 8 most recently accessed setting files
	Exit	Quits the program and prompts to save the document if it is not saved
Edit	Undo	Undo last action
	Cut	Cut the selection and puts it on the clipboard
	Copy	Copy the selection and puts it on the clipboard
	Paste	Paste the copied contents
	Copy Graph	Copy the graph for the active screen to the clipboard

Table 6.1: Windows Menu		
	Copy Setting Group	Copy values from one Setting Group to another
Tools	Options	Print settings for only enabled settings Summary sheet
Window	Cascade	Cascades all open windows
	Tile	Tiles all open windows
	Hide/Show Tree	If this option is checked then the LHS Tree view will be hidden
	1 – 9, More Windows	Allows access to all open Offliner setting files. The active document will have a check beside it
Help	User Manual	On clicking Displays the user manual
	About Offliner	Displays the Offliner version
Toolbar	New	Create a new document of the most recent setting version
	Open	Open an existing document
	Save	Save the active document
	Cut	Cut selection
	Copy	Copy the selection
	Paste	Insert clipboard contents
	Undo	Undo last action
	Copy Graph	Copy the graph for the active screen to the clipboard
	Copy Setting	Brings up the Copy Inputs dialog box
	Print	Prints Graphs or the setting summary, depending on which seen is selected
	Show/Hide LHS Tree	If this option is checked then the LHS Tree view will be hidden or shown
	About	Displays the Offliner version

6.4 Offliner Keyboard Shortcuts

The following table lists the keyboard shortcuts that Offliner provides.

Table 6.2: Keyboard Shortcuts	
Ctrl+N	Opens up a default setting file of the most recent setting version
Ctrl+O	Open an existing setting file
Ctrl+S	Saves the active setting file
Ctrl+Z	Undo
Ctrl+X	Cut
Ctrl+C	Copy
Ctrl+V	Paste
Ctrl+F4	Closes the active Offliner setting document
Ctrl+F6	Switches to the next open Offliner setting file, if more than one setting file is being edited
F6	Toggles between the LHS Tree view and HRS screen
F10, Alt	Enables menu keyboard short-cuts
F1	Displays the user manual

Graphing Protection Functions

Grid On/Grid Off

The graph can be viewed with the grid on/off by clicking the Grid On / Grid Off button. A right-click on the trace of the curve gives user the x and y coordinates.

Print Graph

To print a particular graph, click the *Print Graph* button.

Refresh

This button will manually refresh the graph if it has been zoomed.

Zoom on Graphs

Graphs can be zoomed to bring portions of the traces into clearer display. Left- click on any graph and drag to form a small box around the graph area. When user release the mouse, the trace assumes a new Zoom position determined by the area of the zoom coordinates.

To undo the zoom on the graph, click the Refresh button.

6.5 Handling Backward Compatibility

Offliner Settings displays the version number in the second pane on the bottom status bar. The settings version is a whole number (v1, v2, v3, v4, etc.).

The Offliner Settings is backward compatible. Open and edit older settings files and convert older settings files to a newer version. Offliner Settings handles forward conversion only; it converts an older setting file to a newer setting file

Converting Settings File

1. Open the setting file user wish to convert.
2. In the *File* menu, select *Convert to...* and then select the *version x* (where x is the newer version). A dialog box pops up prompting Offliner for a new file name. Use either the same file name or enter a new file name. The conversion process inserts default values for any newly added devices in the new setting file. When the conversion is complete, Offliner Settings displays the new file.

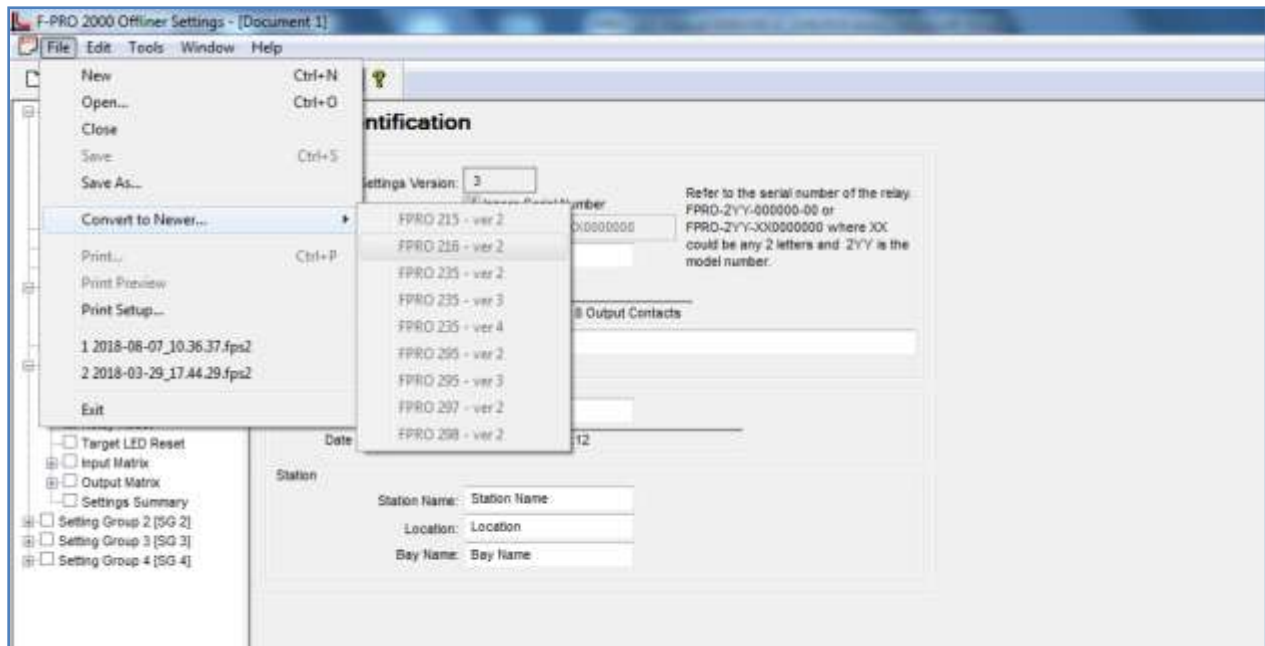

Figure 6.3: Converting Setting Files

Sending a New Setting File to the Relay

1. Make sure the settings version and the serial number of the relay in the setting file match. The relay will reject the setting file if either the serial number or the settings version does not match.

A “serial number discrepancy” message may appear. This is to ensure that user is aware of the exact relay in which settings are to be loaded. If this happens, check the relay serial number using the terminal mode ID menu item. Type this serial number into the F-PRO Serial No.box in the Identification tab display area of Offliner Settings. Alternately user may check the Ignore Serial Number check box to bypass serial number supervision.

2. Check the serial number and the settings version of the relay. The Device Serial Number and Required Settings Version on the Identification screen indicate the serial number and the settings version of the relay.

Creating a Setting File from an Older Version

1. Offliner Settings displays a default setting version on start up in the bottom status bar. As an example F-PRO Offliner is shipped with a set of default sample files of older settings versions. The sample file is “v1 sample.fps”. The sample file contains default values of an older settings version.

For a new installation these sample files are placed in the default directory C:\Program Files\ERL\F-PRO Offliner Settings or user can choose the path during the Offliner software installation. If an older version of F-PRO Offliner was previously installed on user PC, then the default directory may be C:\Program Files\apt\F-PRO Offliner Settings.

2. Open a sample file of the desired version. Use *File/Save As* to save the sample file to a new file name. Then edit the setting file and the serial number, save it and load it into the relay.

6.6 Main Branches from the Tree View

Identification

This section will describe the tree view, which provides access to the various setting screens. This section will not describe individual settings, but will provide a general description of where to find the individual settings. For a detailed description of the individual settings see Chapter 3.

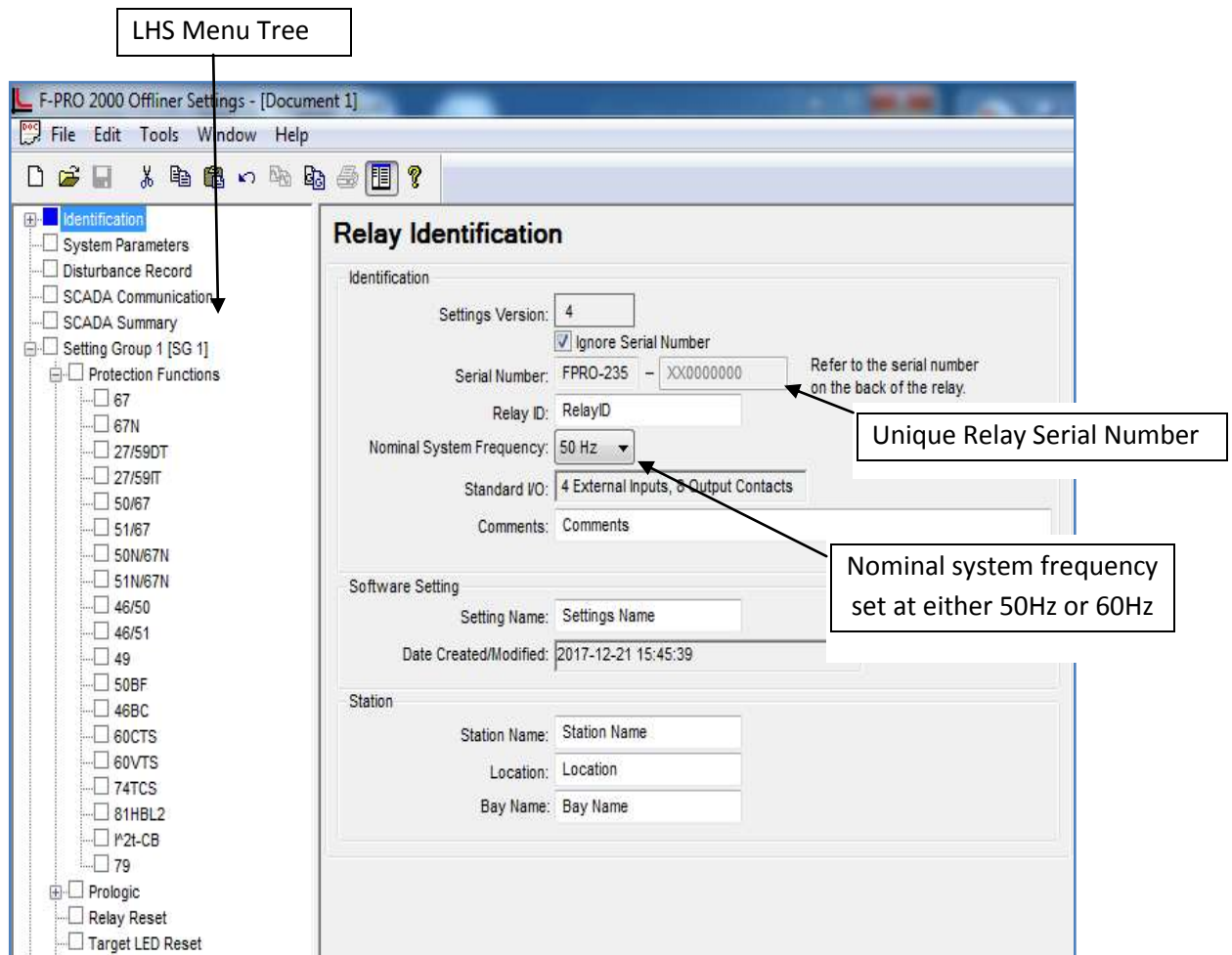

Figure 6.4: Relay identification

In the LHS Menu Tree there are a series of menu headings that may have sub menus associated with them. Clicking on an item in the left hand side tree view will display its corresponding menu in the RHS view. Similarly, the user can use the arrow keys to scroll through the menu tree.

The first screen presents all the menu items in the left menu tree. Access the menu items by clicking the tabs at the top of the screen or the item on the left menu tree.

Table 6.3: Relay Identification

Relay Identification	
Identification	
Settings Version	Indicates the settings version number, fixed.
Ignore Serial Number	Bypass serial number check, if enabled.
Serial Number	Available at the back of each relay.
Relay ID	User-defined up to 16 characters.
Nominal System Frequency	60 Hz or 50 Hz
Comments	User-defined up to 78 characters.
Setting Software	
Setting Name	User-defined up to 16 characters.
Date Created/Modified	Indicates the last time settings were entered.
Station	
Station Name	User-defined up to 16 characters.
Location	User-defined up to 16 characters.
Bay Name	User-defined up to 16 characters.

Important Note

Nominal CT Sec. Current can be set to either 1 A or 5 A. Nominal System Frequency can be set to either 50 Hz or 60 Hz. Ensure setting selection matches that of target F-PRO

The serial number of the relay must match the one in the setting file, or the setting will be rejected by the relay. This feature ensures that the correct setting file is applied to the right relay.

Choose to ignore the serial number enforcement in the identification screen by checking the *Ignore Serial Number* check box. The relay only checks for proper relay type and setting version if the ignore serial number has been chosen, requires relay firmware version 1.0 or greater.

External Inputs

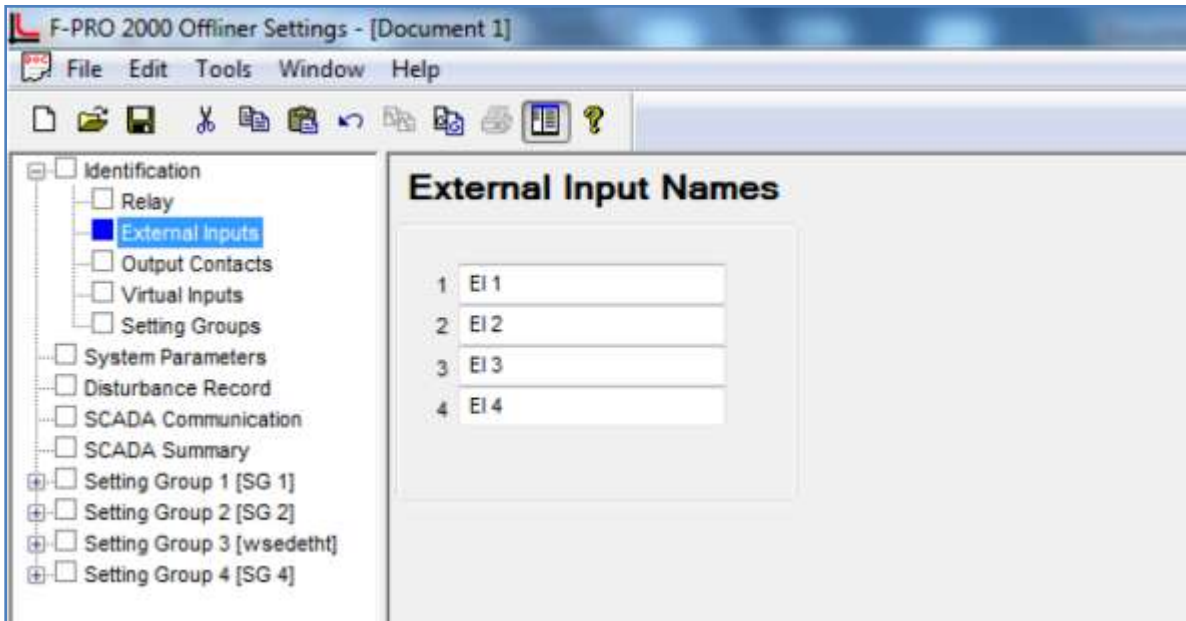

Figure 6.5: External Inputs

The External Inputs screen allows user to define Applicable names for four external inputs.

1 to 4	User-defined
--------	--------------

Output Contacts

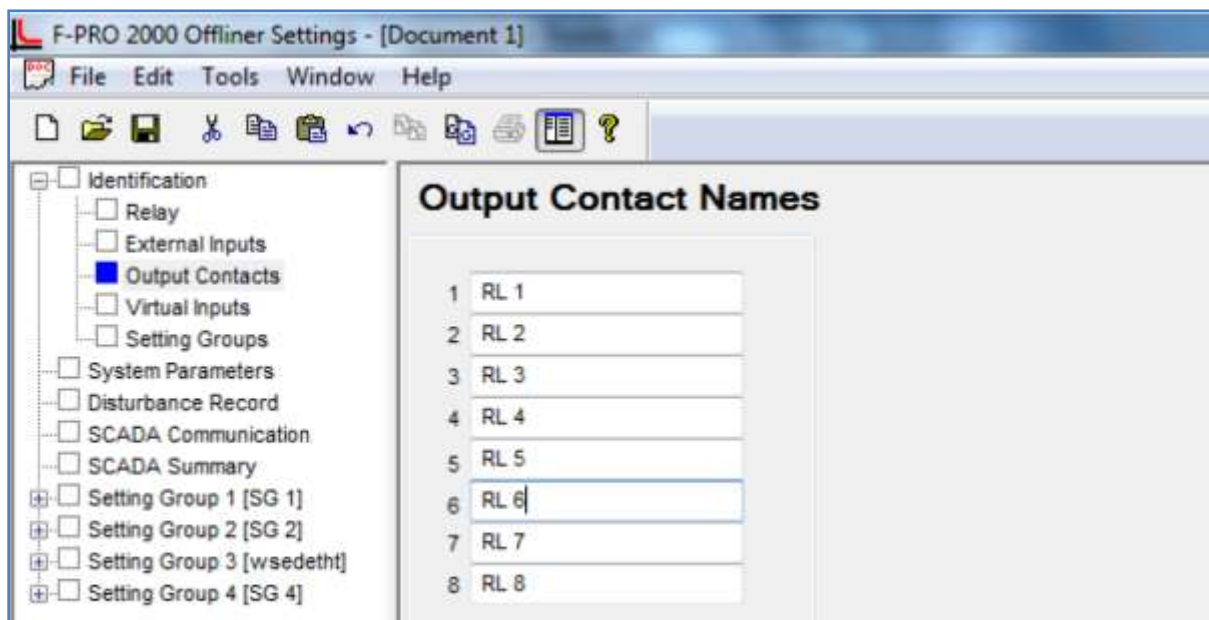

Figure 6.6: Output Contacts

The Output Contact Names screen allows user to define Applicable names to the 8 output contacts.

Table 6.5: Output Contact Names	
Outputs 1 to 8	User-defined

Virtual Inputs

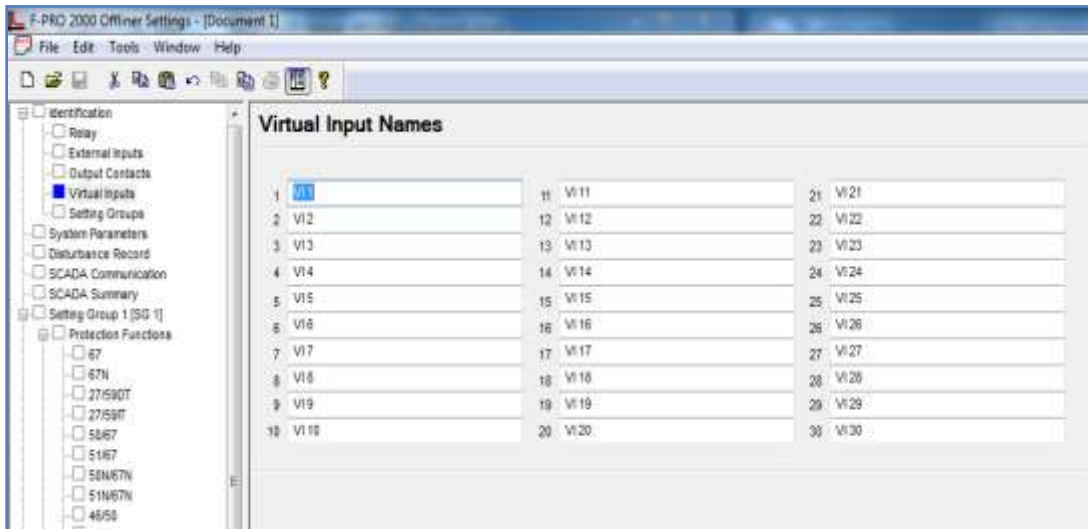

Figure 6.7: Virtual Inputs

Table 6.6: Virtual Inputs	
Virtual Inputs 1 to 30	User-defined

The relay can control its internal functions and connected devices both locally and remotely. Thirty general purpose logic points are accessible via IEC 61850 and the terminal VI. The 30 virtual inputs are individually controlled and include a set / reset and pulse function through RCP. The latch state is retained during setting changes and relay power down conditions. The 30 virtual inputs conform to IEC 61850 standards.

Use virtual inputs are used for:

- Logic functions
- Enable or disable reclosing
- Enable or disable under-frequency load shedding
- Change setting groups
- Provide interlocking between local/remote supervisory control

Setting Groups



Figure 6.8: Setting Groups

The relay has four setting groups (1 to 4). User can change all relay setting parameters except the physical connections such as input or output parameters in each setting group. Use any one of the 4 available Group change inputs per setting group to perform Setting Group changes.

Table 6.7: Setting Groups

Table 6.7: Setting Groups	
Setting Groups 1 to 4	User-defined

System Parameters

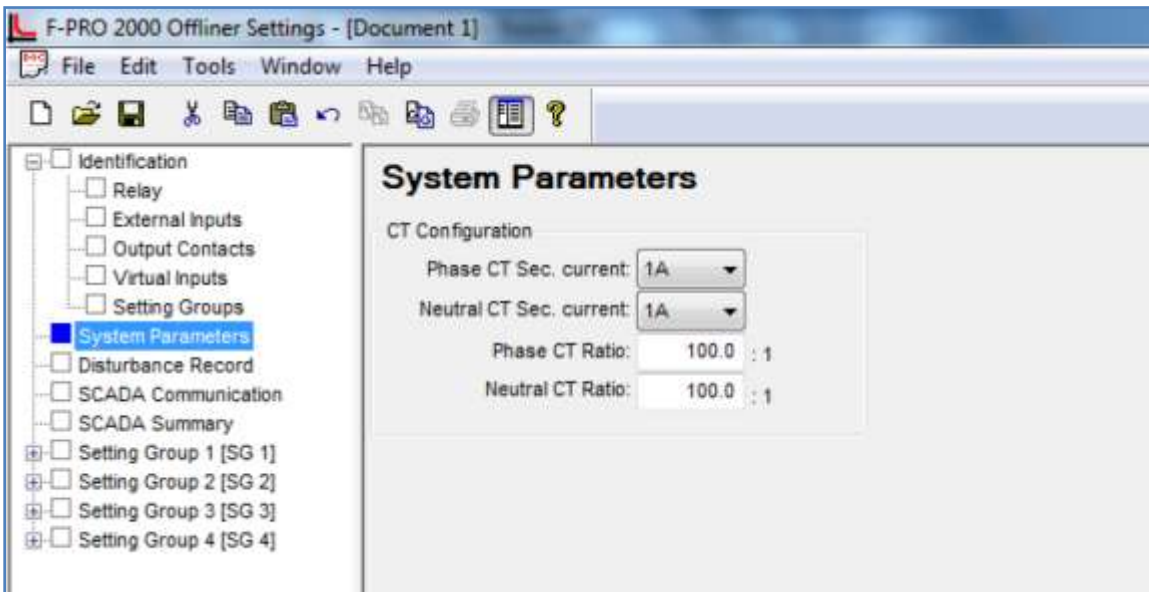

Figure 6.9: System Parameters

The System Parameters screen allows user to define CT Secondary, VT Secondary and VT Ratio for the respective bays.

Table 6.8: System Parameters	
CT Configuration	
Phase CT Sec. Current	1A/ 5A
Phase CT ratio	1.0 to 30000.0
Phase VT Sec	40.0 to 160.0
Phase VT Ratio	1.0 tp 10000.0

Record Length

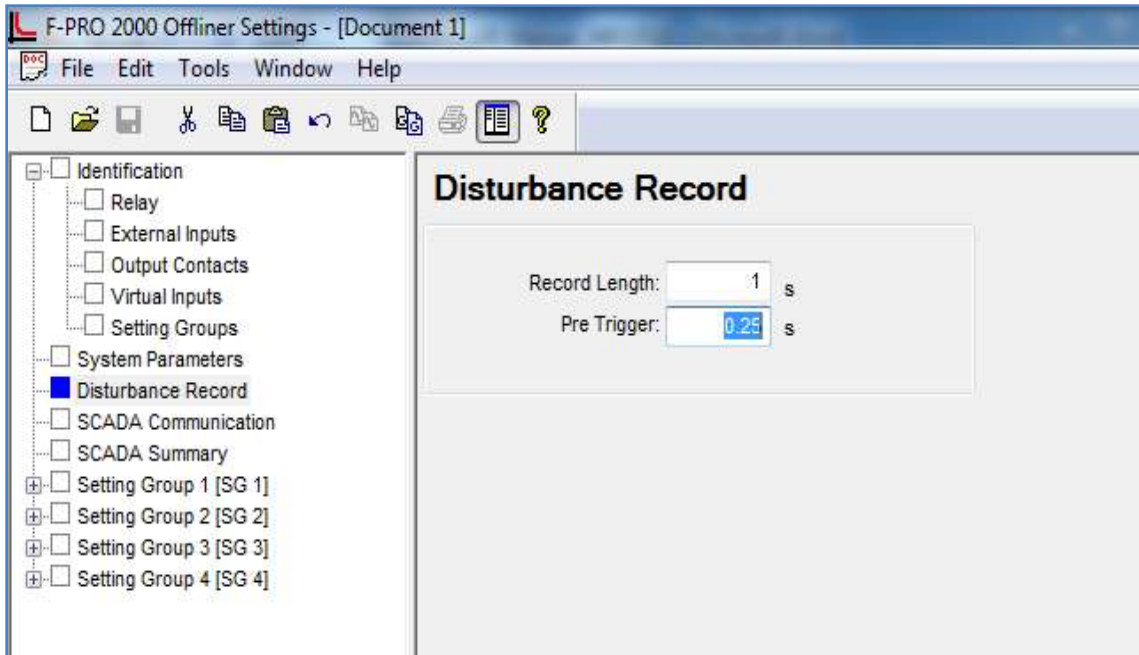

Figure 6.10: Record Length

Table 6.9: Record Length	
Fault Record Length	1 to 20 seconds
Pre-trigger	0.10 to 0.50 seconds

The relay has recording and logging functions to analyze faults and to review the operation of the overall protection scheme and has flexible pre-fault & Record Length timing option.

SCADA Communication

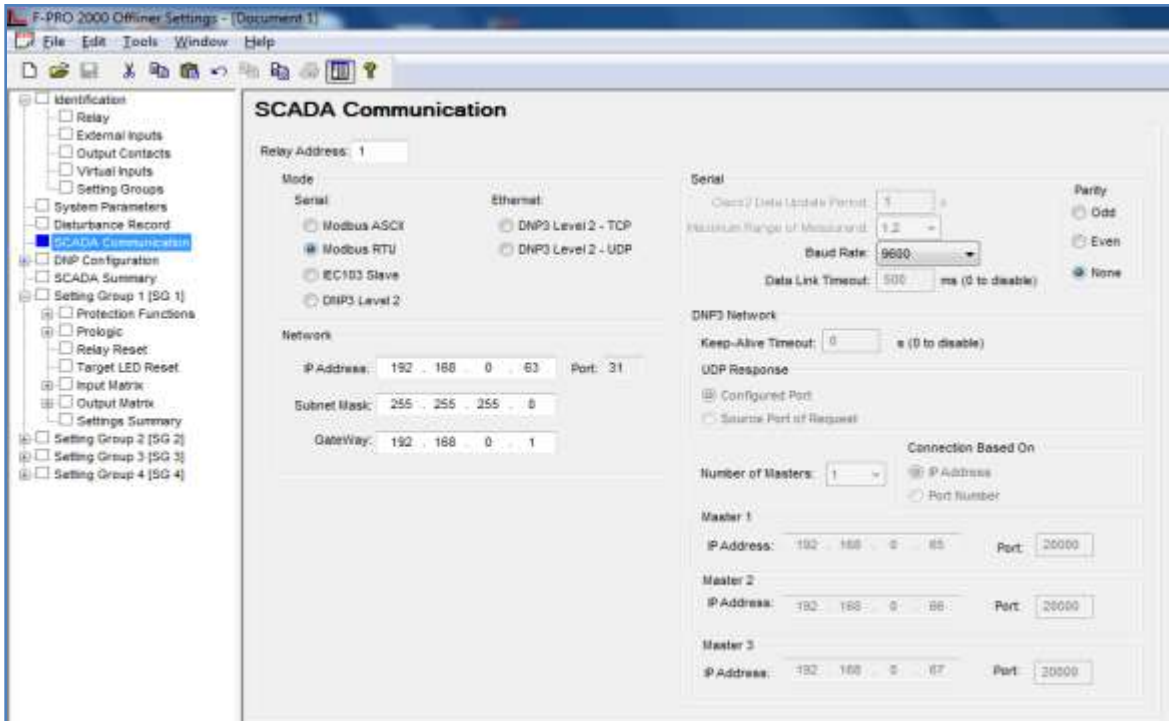

Figure 6.11 SCADA communication

The SCADA Communication screen allows user to configure both Serial protocols (Modbus ASCII/ Modbus RTU / IEC103 Slave / DNP3 Level2) and Ethernet (TCP & UDP). For DNP3 Level2 up to 3 independent masters are supported.

Also the SCADA Communication screen allows to change the network information like IP Address, Subnet Mask and Gateway. If the new setting file is loaded in to the relay with different IP address, then the relay connection will be disconnected and reboot.

DNP Configuration-Point Map

The relay has configurable DNP point mapping. On the Point Map screen, any of the configurable points may be added or removed from the Point List by clicking (or using the cursor keys and space bar on the keyboard) on the associated check box. A green 'X' denotes that the item will be mapped to the Point List. The list contains separate sections for Binary Inputs, Binary Outputs, and Analog Inputs. The list is scrollable by using the scroll control on the right hand side.

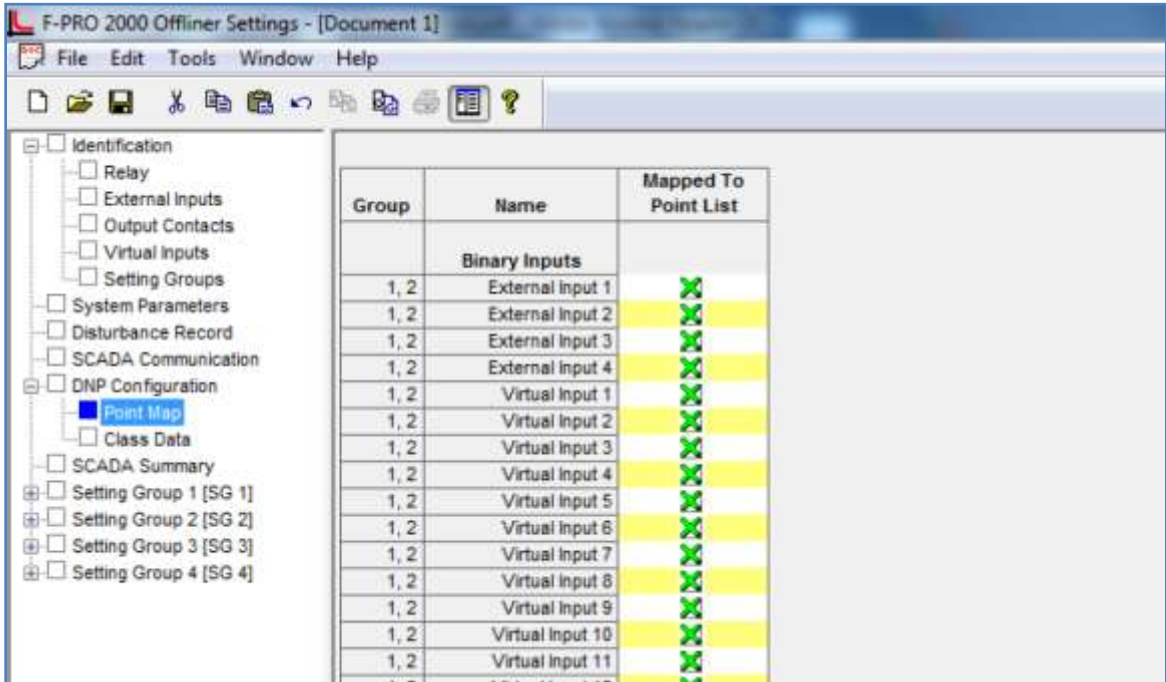

Figure 6.12: Point Map

DNP Configuration Class Data

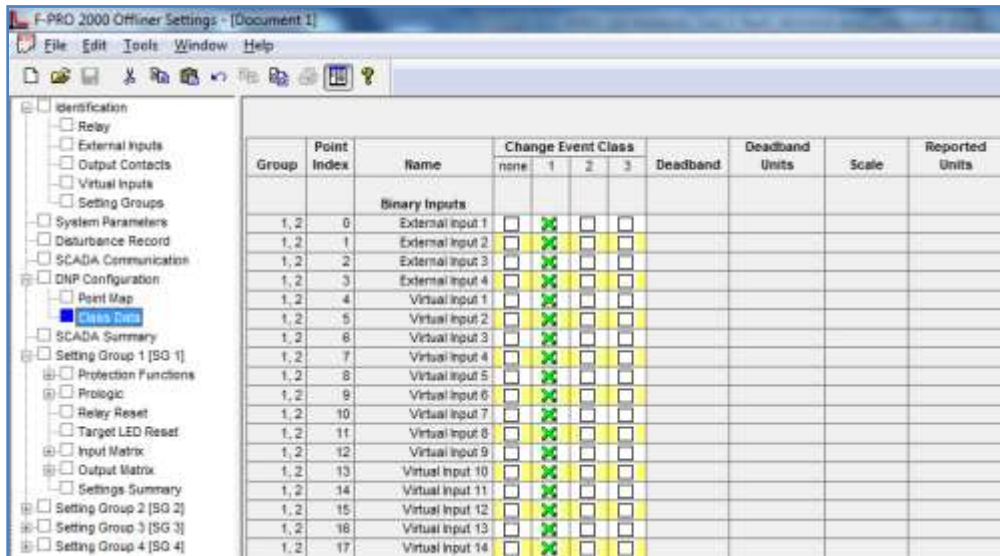

Figure 6.13: Class Data

Class data for each DNP point can be assigned on the Class Data screen. Only Points which were mapped in the Point Map screen will appear here. Sections for Binary Inputs and Analog Inputs appear here; Binary Outputs cannot be assigned a Class. The list is scrollable by using the scroll control on the right hand side.

In addition to assigning a Change Event Class to each mapped point, most Analog Inputs can also be assigned a Deadband and Scaling factor.

SCADA Summary

F-PRO SCADA Summary							
Name	Value/Group	Point Index	Change Event Class	Deadband	Deadband Units	Scale	Reported Units
SCADA Communication							
Relay address	1						
Mode	Serial Modbus RTU						
Baud Rate	9600						
Parity	None						
Class2 Data Update Period	1						
Maximum Range of Measurand	1.2						
Data Link Timeout	500						
Keep-Alive Timeout	0						
UDP Response	Configured Port						
Number of Masters	1						
Connection Based On	IP Address						
Master 1 IP Address	192.168.0.65						
Master 1 Port	20000						
Master 2 IP Address	192.168.0.66						
Master 2 Port	20000						
Master 3 IP Address	192.168.0.67						
Master 3 Port	20000						
IP Address	192.168.0.63						
Port	20000						
Subnet Mask	255.255.255.0						
GateWay	192.168.0.1						

Figure 6.14 SCADA summary

The relay address can be set from 1 to 247 for serial mode of communication either Modbus RTU / Modbus ASCII and can be set from 0 to 254 for IEC103 Slave and can be set from 1 to 65519 for DNP3 and also possible to set baud rate & parity. The relay IP address can be set for the purpose of relay configuration as well as IEC61850 and DNP3 communication (SCADA).

Setting Groups

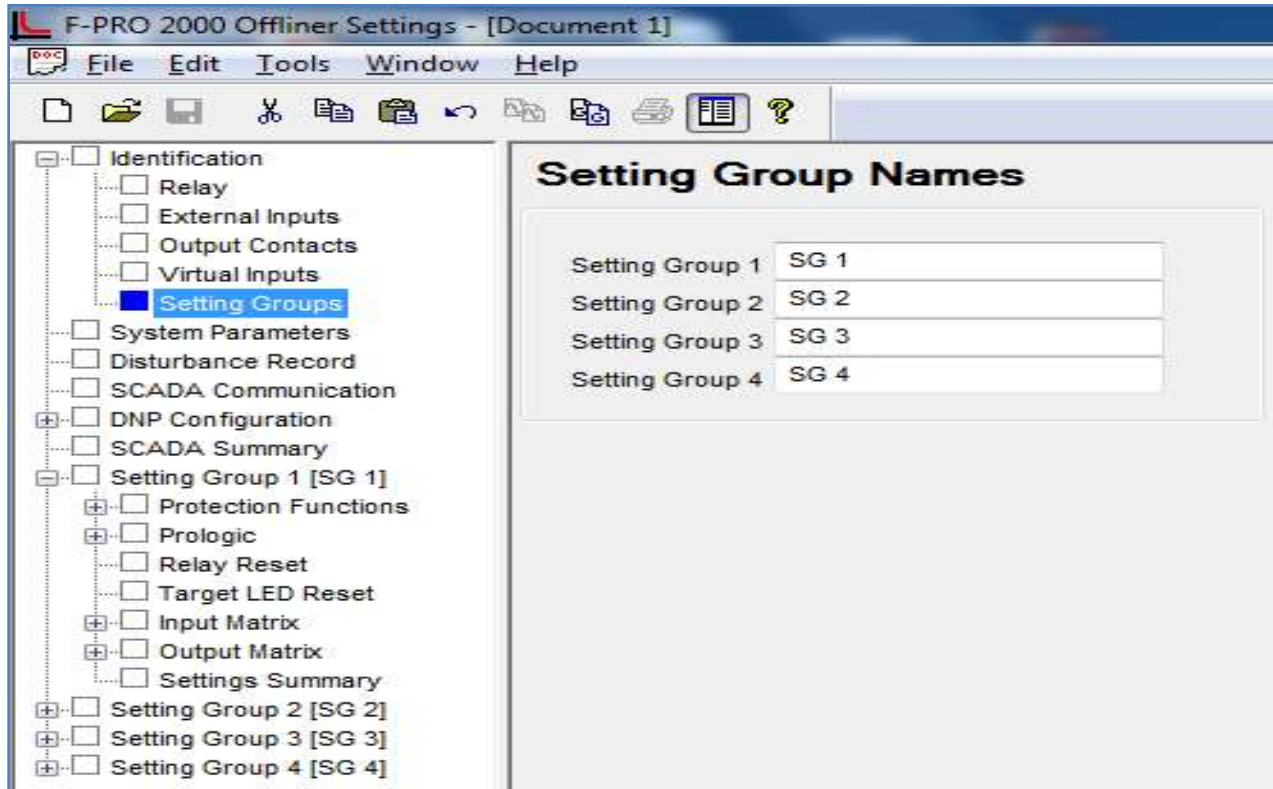

Figure 6.15: Setting Groups Comments

The relay has four setting groups (1 to 4). User can change all relay setting parameters except the physical connections such as input or output parameters in each setting group. Use any one of the 4 available Group change inputs per group.

Protection Functions



Figure 6.16: Protection Functions

F-PRO provides multifunction protection; for detailed descriptions on protection functions see “Protection Functions and Specifications” on page 4-1.

ProLogic

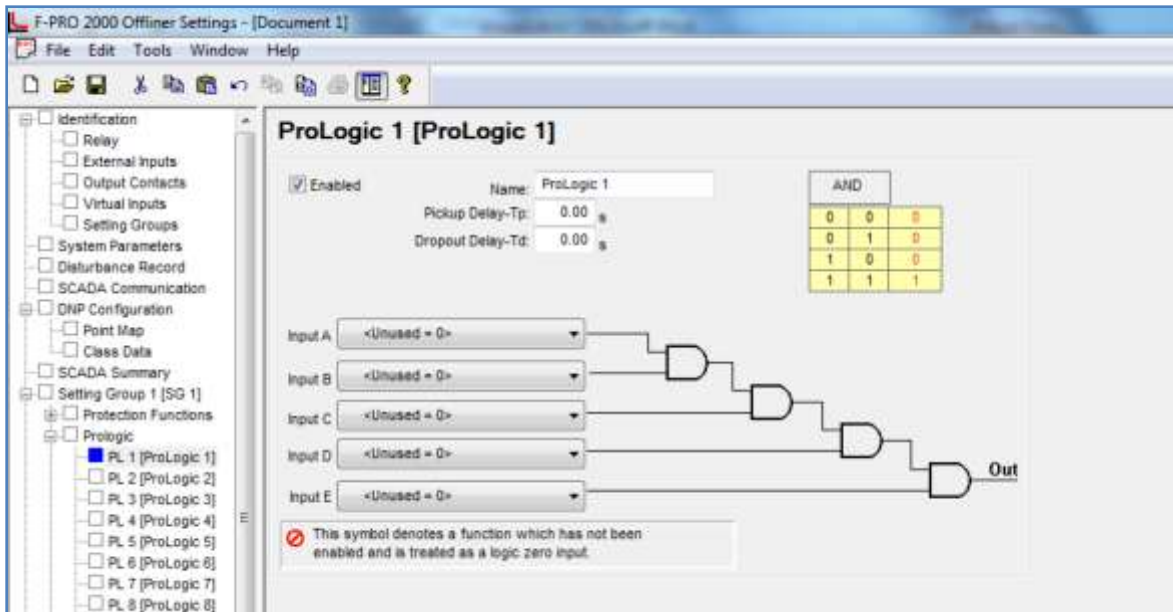

Figure 6.17: ProLogic

ProLogic is used to create an output based on qualified multiple inputs. Twenty User Programmable ProLogic control statements can be utilized to create custom logic and operate output contacts.

User can define or name the function being created and set a pickup and dropout delay. Each ProLogic statement can be used with internal relay functions and external inputs (up to 5 possible inputs) to create the logic output by using Boolean logics such as AND, OR, NAND, NOR, EX-OR, EX-NOR and LATCH.

The output of ProLogic 1 can be nested into ProLogic 2 and so on. If desired, user can illuminate the front target LED on operation of this function by disabling this feature in output matrix. The operations of the ProLogic statements are logged on the events listing. The status of the Prologic can be seen from the record graph by selecting the recorder in the output matrix.

Output Matrix

Logic Output	Output Contact								Block & Initiate			
	1	2	3	4	5	6	7	8	79I	79B	BFI	TDR
Functional	<input checked="" type="checkbox"/>	<input checked="" type="checkbox"/>	<input checked="" type="checkbox"/>	<input checked="" type="checkbox"/>	<input checked="" type="checkbox"/>	<input checked="" type="checkbox"/>	<input checked="" type="checkbox"/>	<input checked="" type="checkbox"/>	<input checked="" type="checkbox"/>	<input checked="" type="checkbox"/>	<input checked="" type="checkbox"/>	<input checked="" type="checkbox"/>
A Phase Operated	<input checked="" type="checkbox"/>	<input checked="" type="checkbox"/>	<input checked="" type="checkbox"/>	<input checked="" type="checkbox"/>	<input checked="" type="checkbox"/>	<input checked="" type="checkbox"/>	<input checked="" type="checkbox"/>	<input checked="" type="checkbox"/>	<input checked="" type="checkbox"/>	<input checked="" type="checkbox"/>	<input checked="" type="checkbox"/>	<input checked="" type="checkbox"/>
B Phase Operated	<input checked="" type="checkbox"/>	<input checked="" type="checkbox"/>	<input checked="" type="checkbox"/>	<input checked="" type="checkbox"/>	<input checked="" type="checkbox"/>	<input checked="" type="checkbox"/>	<input checked="" type="checkbox"/>	<input checked="" type="checkbox"/>	<input checked="" type="checkbox"/>	<input checked="" type="checkbox"/>	<input checked="" type="checkbox"/>	<input checked="" type="checkbox"/>
C Phase Operated	<input checked="" type="checkbox"/>	<input checked="" type="checkbox"/>	<input checked="" type="checkbox"/>	<input checked="" type="checkbox"/>	<input checked="" type="checkbox"/>	<input checked="" type="checkbox"/>	<input checked="" type="checkbox"/>	<input checked="" type="checkbox"/>	<input checked="" type="checkbox"/>	<input checked="" type="checkbox"/>	<input checked="" type="checkbox"/>	<input checked="" type="checkbox"/>
Neutral Operated	<input checked="" type="checkbox"/>	<input checked="" type="checkbox"/>	<input checked="" type="checkbox"/>	<input checked="" type="checkbox"/>	<input checked="" type="checkbox"/>	<input checked="" type="checkbox"/>	<input checked="" type="checkbox"/>	<input checked="" type="checkbox"/>	<input checked="" type="checkbox"/>	<input checked="" type="checkbox"/>	<input checked="" type="checkbox"/>	<input checked="" type="checkbox"/>
27DT-1 Picked up	<input checked="" type="checkbox"/>	<input checked="" type="checkbox"/>	<input checked="" type="checkbox"/>	<input checked="" type="checkbox"/>	<input checked="" type="checkbox"/>	<input checked="" type="checkbox"/>	<input checked="" type="checkbox"/>	<input checked="" type="checkbox"/>	<input checked="" type="checkbox"/>	<input checked="" type="checkbox"/>	<input checked="" type="checkbox"/>	<input checked="" type="checkbox"/>
27DT-2 Picked up	<input checked="" type="checkbox"/>	<input checked="" type="checkbox"/>	<input checked="" type="checkbox"/>	<input checked="" type="checkbox"/>	<input checked="" type="checkbox"/>	<input checked="" type="checkbox"/>	<input checked="" type="checkbox"/>	<input checked="" type="checkbox"/>	<input checked="" type="checkbox"/>	<input checked="" type="checkbox"/>	<input checked="" type="checkbox"/>	<input checked="" type="checkbox"/>
27DT-3 Picked up	<input checked="" type="checkbox"/>	<input checked="" type="checkbox"/>	<input checked="" type="checkbox"/>	<input checked="" type="checkbox"/>	<input checked="" type="checkbox"/>	<input checked="" type="checkbox"/>	<input checked="" type="checkbox"/>	<input checked="" type="checkbox"/>	<input checked="" type="checkbox"/>	<input checked="" type="checkbox"/>	<input checked="" type="checkbox"/>	<input checked="" type="checkbox"/>
27DT-4 Picked up	<input checked="" type="checkbox"/>	<input checked="" type="checkbox"/>	<input checked="" type="checkbox"/>	<input checked="" type="checkbox"/>	<input checked="" type="checkbox"/>	<input checked="" type="checkbox"/>	<input checked="" type="checkbox"/>	<input checked="" type="checkbox"/>	<input checked="" type="checkbox"/>	<input checked="" type="checkbox"/>	<input checked="" type="checkbox"/>	<input checked="" type="checkbox"/>
27DT-5 Picked up	<input checked="" type="checkbox"/>	<input checked="" type="checkbox"/>	<input checked="" type="checkbox"/>	<input checked="" type="checkbox"/>	<input checked="" type="checkbox"/>	<input checked="" type="checkbox"/>	<input checked="" type="checkbox"/>	<input checked="" type="checkbox"/>	<input checked="" type="checkbox"/>	<input checked="" type="checkbox"/>	<input checked="" type="checkbox"/>	<input checked="" type="checkbox"/>
27DT-6 Picked up	<input checked="" type="checkbox"/>	<input checked="" type="checkbox"/>	<input checked="" type="checkbox"/>	<input checked="" type="checkbox"/>	<input checked="" type="checkbox"/>	<input checked="" type="checkbox"/>	<input checked="" type="checkbox"/>	<input checked="" type="checkbox"/>	<input checked="" type="checkbox"/>	<input checked="" type="checkbox"/>	<input checked="" type="checkbox"/>	<input checked="" type="checkbox"/>
27DT-1 Operated	<input checked="" type="checkbox"/>	<input checked="" type="checkbox"/>	<input checked="" type="checkbox"/>	<input checked="" type="checkbox"/>	<input checked="" type="checkbox"/>	<input checked="" type="checkbox"/>	<input checked="" type="checkbox"/>	<input checked="" type="checkbox"/>	<input checked="" type="checkbox"/>	<input checked="" type="checkbox"/>	<input checked="" type="checkbox"/>	<input checked="" type="checkbox"/>
27DT-2 Operated	<input checked="" type="checkbox"/>	<input checked="" type="checkbox"/>	<input checked="" type="checkbox"/>	<input checked="" type="checkbox"/>	<input checked="" type="checkbox"/>	<input checked="" type="checkbox"/>	<input checked="" type="checkbox"/>	<input checked="" type="checkbox"/>	<input checked="" type="checkbox"/>	<input checked="" type="checkbox"/>	<input checked="" type="checkbox"/>	<input checked="" type="checkbox"/>
27DT-3 Operated	<input checked="" type="checkbox"/>	<input checked="" type="checkbox"/>	<input checked="" type="checkbox"/>	<input checked="" type="checkbox"/>	<input checked="" type="checkbox"/>	<input checked="" type="checkbox"/>	<input checked="" type="checkbox"/>	<input checked="" type="checkbox"/>	<input checked="" type="checkbox"/>	<input checked="" type="checkbox"/>	<input checked="" type="checkbox"/>	<input checked="" type="checkbox"/>
27DT-4 Operated	<input checked="" type="checkbox"/>	<input checked="" type="checkbox"/>	<input checked="" type="checkbox"/>	<input checked="" type="checkbox"/>	<input checked="" type="checkbox"/>	<input checked="" type="checkbox"/>	<input checked="" type="checkbox"/>	<input checked="" type="checkbox"/>	<input checked="" type="checkbox"/>	<input checked="" type="checkbox"/>	<input checked="" type="checkbox"/>	<input checked="" type="checkbox"/>
27DT-5 Operated	<input checked="" type="checkbox"/>	<input checked="" type="checkbox"/>	<input checked="" type="checkbox"/>	<input checked="" type="checkbox"/>	<input checked="" type="checkbox"/>	<input checked="" type="checkbox"/>	<input checked="" type="checkbox"/>	<input checked="" type="checkbox"/>	<input checked="" type="checkbox"/>	<input checked="" type="checkbox"/>	<input checked="" type="checkbox"/>	<input checked="" type="checkbox"/>
27DT-6 Operated	<input checked="" type="checkbox"/>	<input checked="" type="checkbox"/>	<input checked="" type="checkbox"/>	<input checked="" type="checkbox"/>	<input checked="" type="checkbox"/>	<input checked="" type="checkbox"/>	<input checked="" type="checkbox"/>	<input checked="" type="checkbox"/>	<input checked="" type="checkbox"/>	<input checked="" type="checkbox"/>	<input checked="" type="checkbox"/>	<input checked="" type="checkbox"/>
27IT-1 Picked up	<input checked="" type="checkbox"/>	<input checked="" type="checkbox"/>	<input checked="" type="checkbox"/>	<input checked="" type="checkbox"/>	<input checked="" type="checkbox"/>	<input checked="" type="checkbox"/>	<input checked="" type="checkbox"/>	<input checked="" type="checkbox"/>	<input checked="" type="checkbox"/>	<input checked="" type="checkbox"/>	<input checked="" type="checkbox"/>	<input checked="" type="checkbox"/>
27IT-2 Picked up	<input checked="" type="checkbox"/>	<input checked="" type="checkbox"/>	<input checked="" type="checkbox"/>	<input checked="" type="checkbox"/>	<input checked="" type="checkbox"/>	<input checked="" type="checkbox"/>	<input checked="" type="checkbox"/>	<input checked="" type="checkbox"/>	<input checked="" type="checkbox"/>	<input checked="" type="checkbox"/>	<input checked="" type="checkbox"/>	<input checked="" type="checkbox"/>
27IT-1 Operated	<input checked="" type="checkbox"/>	<input checked="" type="checkbox"/>	<input checked="" type="checkbox"/>	<input checked="" type="checkbox"/>	<input checked="" type="checkbox"/>	<input checked="" type="checkbox"/>	<input checked="" type="checkbox"/>	<input checked="" type="checkbox"/>	<input checked="" type="checkbox"/>	<input checked="" type="checkbox"/>	<input checked="" type="checkbox"/>	<input checked="" type="checkbox"/>
27IT-2 Operated	<input checked="" type="checkbox"/>	<input checked="" type="checkbox"/>	<input checked="" type="checkbox"/>	<input checked="" type="checkbox"/>	<input checked="" type="checkbox"/>	<input checked="" type="checkbox"/>	<input checked="" type="checkbox"/>	<input checked="" type="checkbox"/>	<input checked="" type="checkbox"/>	<input checked="" type="checkbox"/>	<input checked="" type="checkbox"/>	<input checked="" type="checkbox"/>

Figure 6.18: Output Matrix

The output contact matrix determines which function to initiate which output contact of the relay. All output relays have a settable delay (0 to 1 second).

Functions can also initiate fault recording, recloser blocking, recloser initiation and/or breaker failure initiation.

For a particular function to operate correctly, it must be enabled and must also have its Logic output assigned to at least one output contact if it is involved in a tripping function.

Print the entire output matrix by selecting *File>Print Summary*. This printout is produced on two pages.

Settings Summary

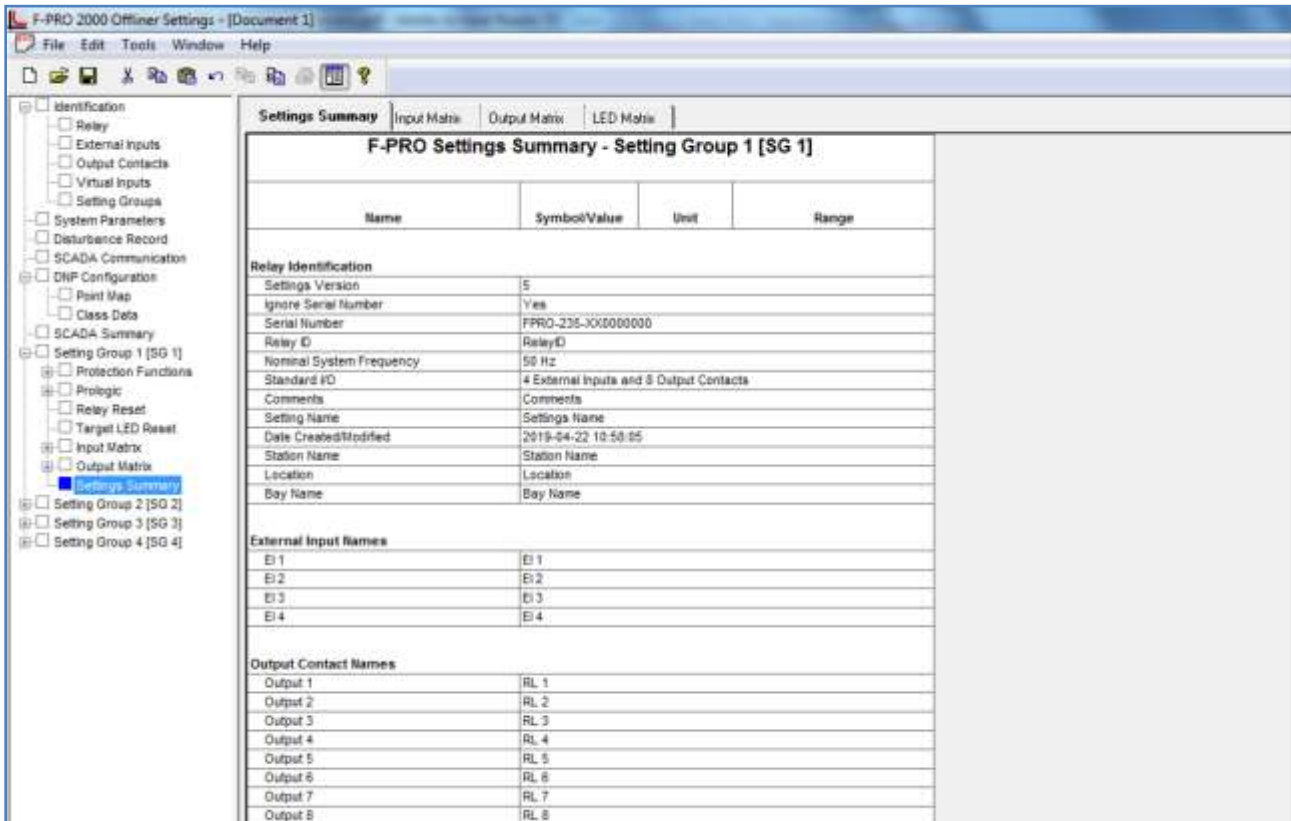

Figure6.19: Settings Summary

Select *Settings Summary* to view and print the relay settings in text form. For details see “IED Settings and Ranges” in [Appendix B](#). Print the entire Settings Summary by selecting *File>Print Summary*.

6.7 Settings from a Record

The settings on the relay at the time of a recording are included in every record and can be viewed through the RecordGraph analysis software. While viewing a recording in RecordGraph, select the *View Setting* button to display the settings. RecordGraph will automatically launch F-PRO Offliner to display the settings in summary form if installed in the same PC.

If the record contains multiple Setting Groups, the Offliner displays all Setting Groups in the summary. Bold text in the tree view indicates an active Setting Group (the Setting Group used at the time the record was captured). The setting summary is read-only. To edit the setting file associated with the summary, user must use *File/Save As* to save the summary to a file. Then close the summary screen and open the setting file for editing in F-PRO Offliner.

6.8 Record Graph Software

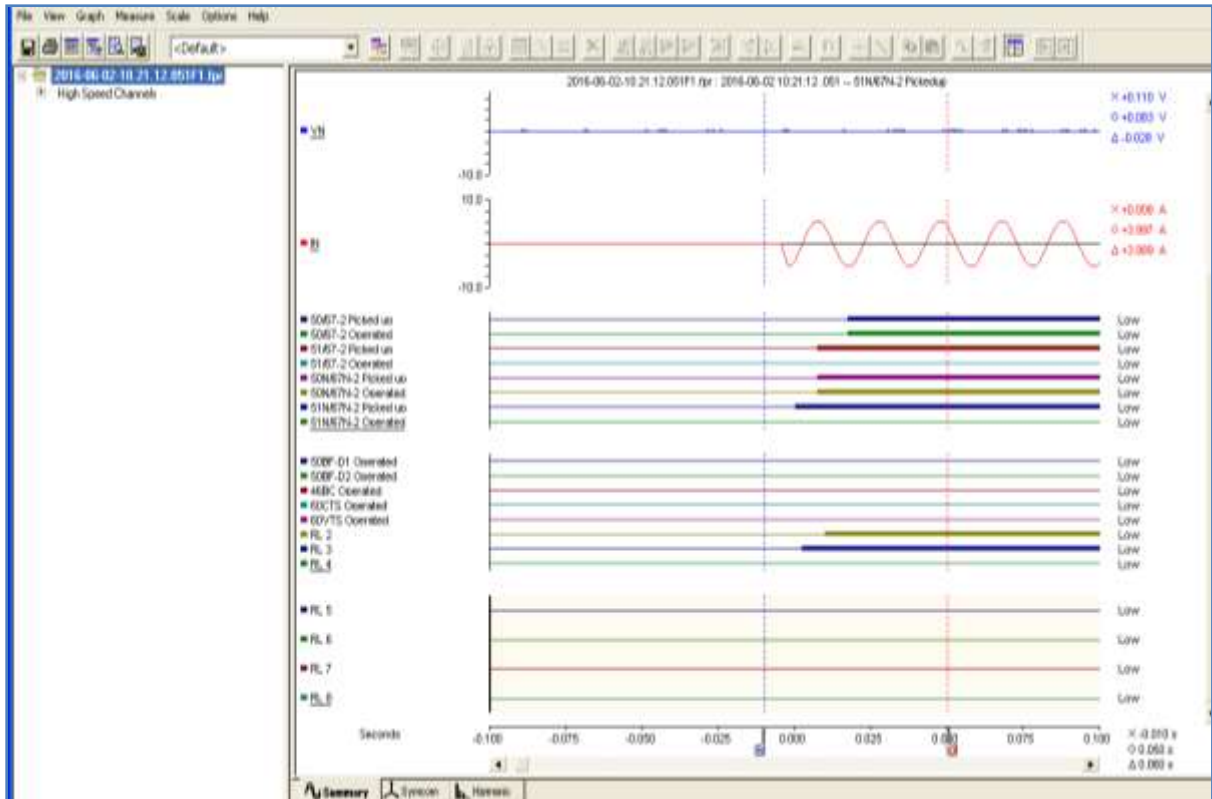

Figure 6.20 Record Graph View

Use RecordGraph to analyze the records from a relay.

1. Set the receive directory on user RCP to point to a convenient directory on user PC's hard disk or network. For example with Relay Control Panel, Select Add New>Folder Placement>Browse. It will be by default in this path *C:\DocumentsandSettings\user\MyDocuments\ERL\RelayControlPanel\Records*.
2. Select one or more records on the relay using the *List* function in the terminal Mode's *Records* menu.
3. Initiate transfer of the selected record by selecting *GET* from Relay tab in the RCP or by double clicking the selected record.
4. Start the RecordBase View program and use the *ADD* tab to open the downloaded record files located in the receive directory specified in step

6.9 ERL 61850 IED Configurator

Introduction

The ERL 61850 IED Configurator is used to configure ERL IEC 61850 based devices for substation automation. This tool helps the user to map data from remote GOOSE into ERL IED data, to perform GOOSE mapping from ERL IEDs to other devices and to map the required RCB (Report Control Block) datasets for SCADA.

The ERL 61850 IED Configurator provides configuration options for GOOSE Control Blocks, Sample Value Control Blocks, Report Control Blocks and Datasets. It also provides GOOSE Mapping and Sample Value Mapping configuration.

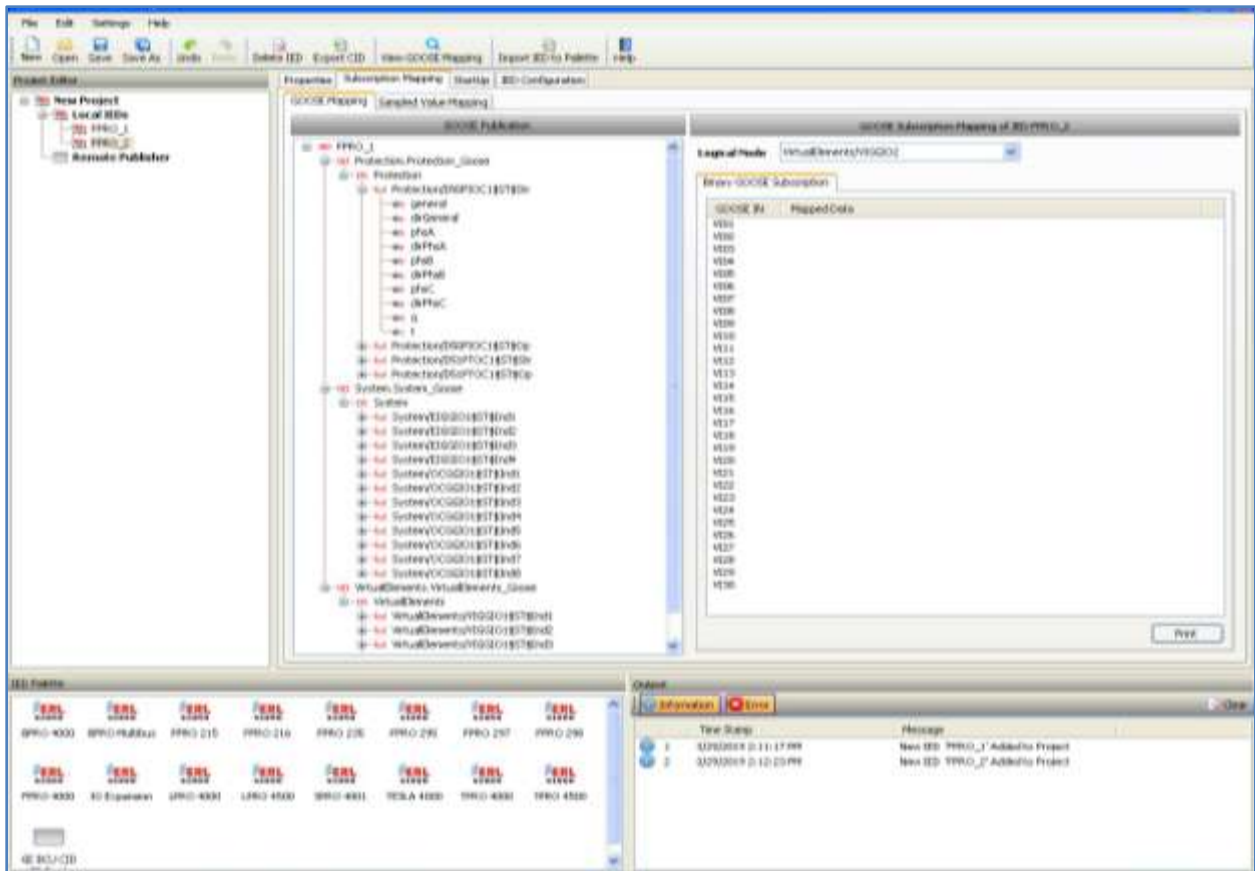

Figure 6.21: ERL 61850 IED Configurator

For further instructions refer to the ERL 61850 IED Configurator Manual.

7 Acceptance / Peripheral Test Guide

7.1 Introduction

The acceptance test section is a guide for testing any and all protection elements in the relay. These tests should be performed upon first delivery of the relay, prior to applying in-service settings. Once in-service settings are applied, ERL recommends that the user test enabled functions to ensure the designed application is fulfilled.

The acceptance testing describes the test equipment requirements, calibration methods, testing the external inputs and testing the output relay contacts.

7.2 Acceptance Testing

ERL relays are fully tested before leaving the factory. A visual inspection of the relay and its packaging is recommended on receipt to ensure the relay was not damaged during shipping.

The electronics in the relay contain static sensitive devices and are not user-serviceable. If the front of the relay is opened for any reason exposing the electronics, take extreme care to ensure that the user and the relay are solidly grounded.

Generally an analog metering check, as well as testing the I/O (External Inputs and Output Contacts) is sufficient to ensure the functionality of the relay. Further tests can be performed on delivery and acceptance of the purchaser's option according to the published relay specifications in "IED Settings and Ranges" in [Appendix B](#).

Test Equipment Requirements

- 3 phase ac voltage sources (variable frequency capability)
- 3 phase ac current sources
- 1 ohmmeter
- 1 – 300 Vdc source

Set nominal CT secondary current to either 1 A or 5 A, and nominal system frequency to either 50 Hz or 60 Hz.

Calibration

The relay is calibrated before it leaves the factory, but if component changes are made within the relay, the user may need to do a re-calibration.

Before beginning a new calibration, establish the accuracy of the equipment being used.

To perform a calibration, the user must be logged into the relay using Relay Control Panel at the change/Service access level to the front USB/Ethernet Port.

1. Proceed to the *Utilities>Analog Input Calibration* tab. the Analog Input Calibration screen lists all of the F-PRO analog input channels.
2. Select the channel to calibrate with your mouse (you may select and calibrate multiple channels at once as long as they are the same qualities).
3. Enter the exact Magnitude of the *Applied Signal* you are applying your test source.
4. Execute the *Calibrate Offset and Gain* button.

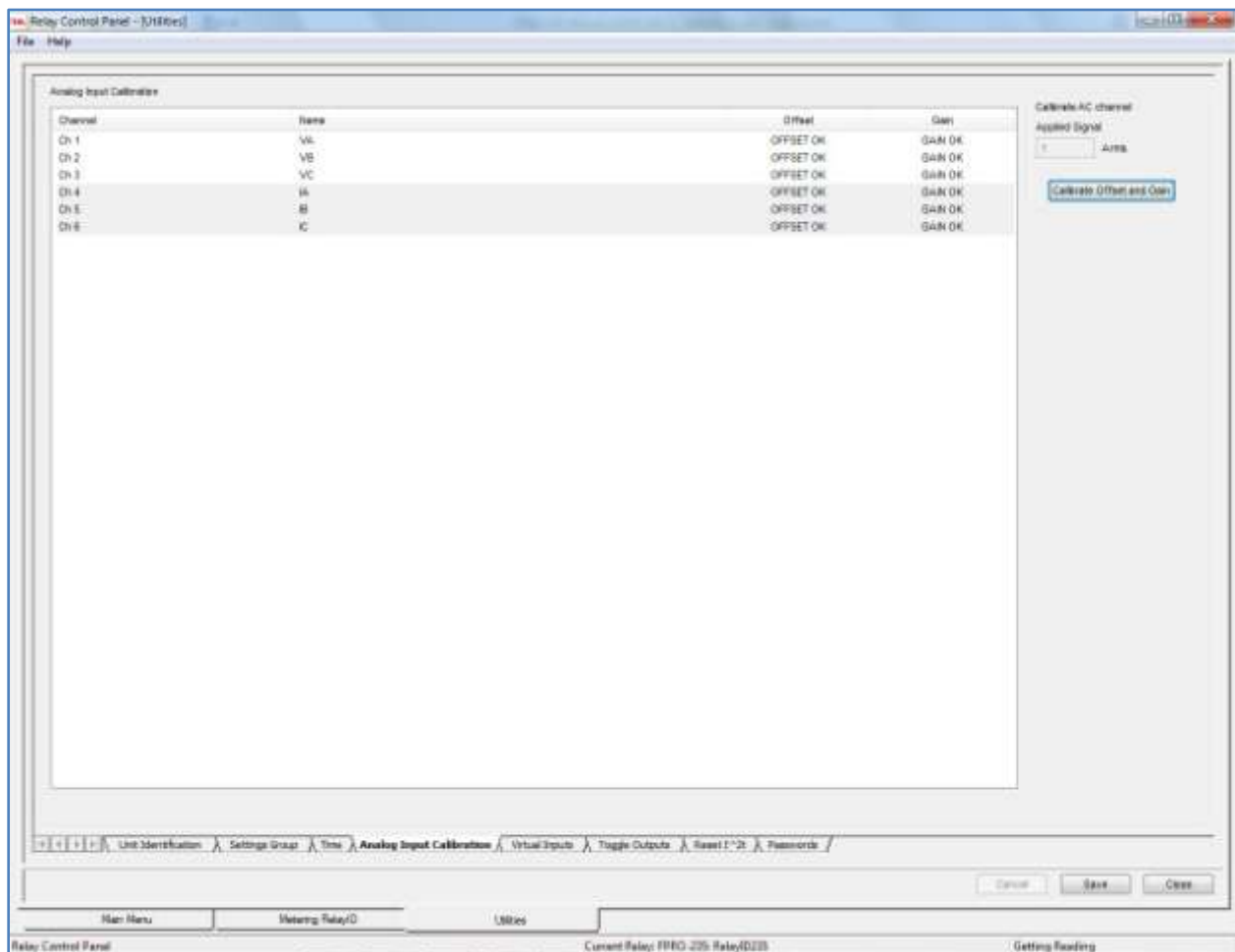

Figure 7.1: Enter actual applied signal level

If the applied test signal is not reasonable, an error will be displayed and the calibration will not be applied. For example, in Figure 7.2: on page 7-3, the displayed calibration error message indicates that we tried to calibrate a 63.5 V level with no voltage applied, which is not reasonable.

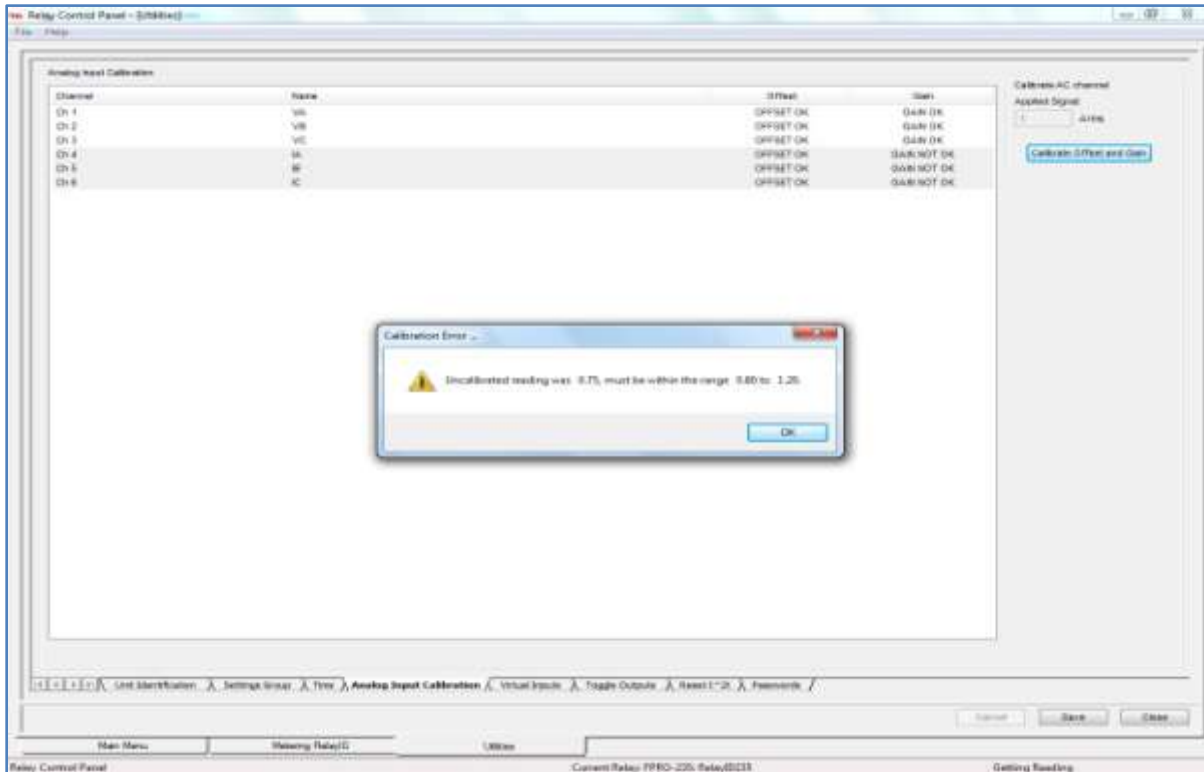

Figure 7.2: Calibration error – out of range

Only the magnitude (Gain) and offset are calibrated, space not the angle

When an analog input channel is calibrated, you can verify the quantity measured by selecting the Metering menu and the Analog Quantity submenu.

Testing the External Inputs

External Inputs are polarity sensitive !

To test the external inputs connect the relay using Relay Control Panel, *Metering>External Inputs*. This screen displays the status of the Input and Output Contacts. If the relay is 110V dc variant place a voltage of 110 V dc nominal, (135 V dc maximum), to each of the external inputs in turn causes the input to change from Low to High status. These inputs are polarity sensitive and this screen has a 0.5 second update rate.

Testing the Output Relay Contacts

Access the F-PRO service level in Relay Control Panel. Open the *Utilities>Toggle Outputs* tab screen. To toggle outputs you first need to enter *Test Mode* by selecting the *Relay in Test Mode* check box. When you check the box, a message will appear prompting you to confirm that you really want to enter this mode. Once you enter Test Mode, the functional green LED on the front of the F-PRO will blink and it will remain blinking until you exit Test Mode. The protection functions cannot access the output contacts in Test Mode; they are controllable only by the user via Relay Control Panel. To toggle a particular output, select it from the drop down list and then click on the *Closed* button. You can verify the contact is closed with an ohmmeter. The contact will remain closed until you either click the *Open* button or exit Test Mode.

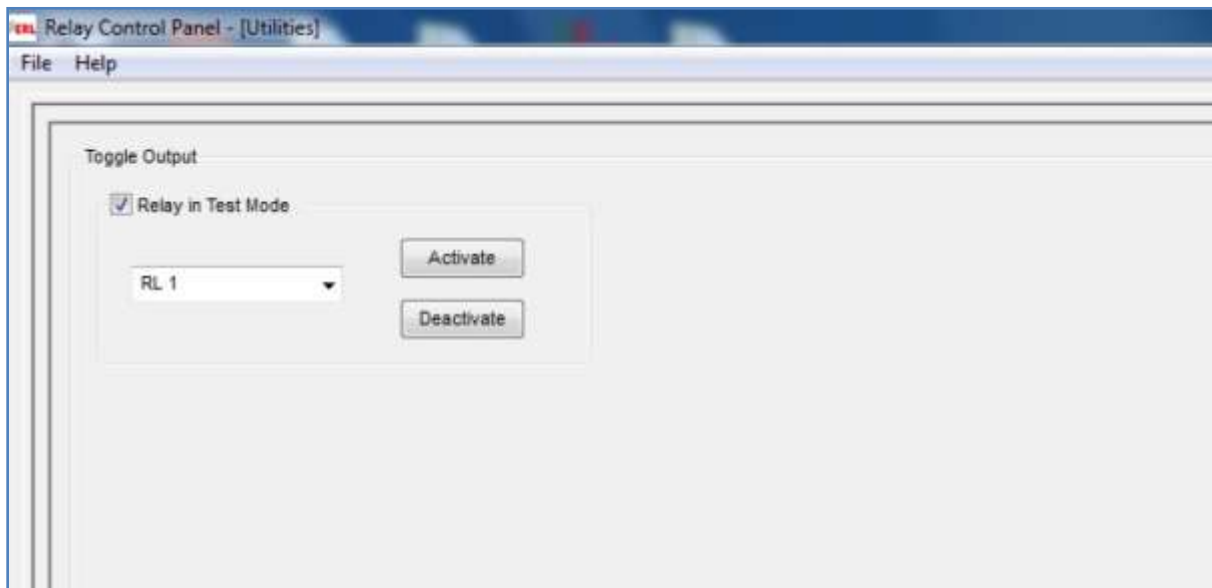

Figure 7.3: Test output Contacts

8 Installation

8.1 Introduction

This section details the installation of the F -PRO relay. The section covers the physical mounting, AC and DC wiring and the Communication wiring.

8.2 Physical Mounting

Standard E6

The relay is 177 mm height and 242.5mm depth (Approximately). The standard relay is designed for a 155 mm width. A complete mechanical drawing is shown, for details see “Mechanical Drawings” in [Appendix H](#)

To install the relay the following is needed:

- E6 cutout (159 x 150 mm)
- M4 screws & Nuts

8.3 AC and DC Wiring

For details see “AC Schematic Drawing” in [Appendix I](#) and “DC Schematic Drawing” in [Appendix J](#).

8.4 Communication Wiring

EIA-485

The relay’s serial port (COM 2) is an EIA RS-485 Data Communications Equipment (DCE) device. This allows them to be connected directly to other relays in parallel and communicated to a PC serial port with a standard straight-through male-to-female serial cable with RS485 to RS232 convertor. RS 485 cable can work for maximum 1.2kM with single IED. Shielded cable is recommended, for pin -out see “[Communication Port Details](#)”

Ethernet Port

100BASE Ethernet Port (COM 3) with RJ-45/FO receptacle on rear side of the relay can be used with CAT5 or CAT5e straight or ST type FO for SCADA Communications. The maximum distance that RJ45 cable can support is 100meters (328 feet)

USB

COM 1 on the front panel is a standard USB-B connector. This port is the Maintenance port of the relay. This is a USB 2.0 Full Speed interface and can be connected to a PC with a standard USB peripheral cable (A style to B style).

IRIG-B

IRIG-B on the rear panel accepts both modulated and un-modulated IRIG -B standard time signals with or without the IEEE 1344 extensions. The IRIG-B connector on the back of the relay is BNC type. SNTP Time sync through RJ-45/FO can also be achieved.

Appendix A IED Specifications

F-PRO 235 Specifications		
Item	Quantity/Specs	Note
General:		
Nominal Frequency	50 or 60 Hz	
Operating Time	Less than 30 ms	Including output relay operation.
Memory	Settings and records are stored in non-volatile memory	Records are stored in a circular buffer
Power Supply	20 to 60Vdc 80 to 300Vdc / 80 to 240Vac , 50/60Hz	Power Consumption: 5 – 6 VA (ac) 4.5 – 5 W (dc)
Protection Functions:		
27/59DT (1-6), 27/59IT (1-2), 50/67 (1-2), 51/67 (1-2), 50N/67N (1-2), 51N/67N (1-2), 46/50, 46/51, 49, 50BF, 46BC, 60CTS, 60VTS, 74TCS (1-2) 81HBI2, I ² t, 79	1 x 3-phase current inputs 1 x 3-phase voltage inputs	
ProLogic	20 statements per setting group	5 inputs per ProLogic™ statement
Setting Groups	4	
Recording:		
Transient (Fault)	32 s/c oscillography of all analog and external input digital channels	User-configurable 1 to 20 seconds Record length and 0.1 to 0.5 pre-fault length
A/D Resolution	6 bits, 65536 counts full scale peak	
Events	1000 events circular log with 1ms resolution I ² t: trigger by user defined event and/or trip	A compressed event record can be created 1000 events with manual trigger.
Record Capacity	20 records of transient and optionally event records.	

F-PRO 235 Specifications		
Input & Output:		
Analog Current Inputs 1 set of 3-phase current inputs	Nominal Current Continuous Maximum full-scale Thermal rating Burden	In = 1 Amp or 5 Amps 4x In = 4 Amps or 20 Amps 40x In for 3 second symmetrical 100 Amps for 1 second <0.1 VA @ 1 Amp <0.5 VA @ 5 Amps
Analog Voltage Inputs 1 set of 3-phase voltage inputs	Nominal Voltage Continuous Maximum full-scale Burden	Vn = 3-139Vac 139 Vrms 200 Vrms for 10 seconds <0.15 VA @ 63.5 Vrms
Analog Sampling Rate	32 samples/cycle for recording 8 samples/cycle for protection	Records up to 8 th harmonic
External Inputs (digital)	4 isolated inputs	Optional 24, 48, 110, 220 V dc Nominal, externally wetted
Isolation	2 KV optical isolation	
External Input Turn-on Voltage	24Vdc nominal = 19 Vdc 48Vdc nominal = 38 Vdc 110Vdc nominal = 88 Vdc 220Vdc nominal = 175 Vdc	
Output Relays (contacts)	8 programmable outputs (6NO +2CO)	Externally wetted Make: 30 A as per IEEE C37.90 Carry: 8 A Break: 0.9 A at 125 Vdc resistive 0.35 A at 250 Vdc resistive
Virtual Inputs	30 Virtual Inputs	
Interface & Communication:		
Front Display	2 row 16 character Alpha Numeric LCD	
Front Panel Indicators	8 LEDs: 7 programmable, 1 fixed	
Front User Interface	USB port	Full Speed USB 2.0 480Mbps
Rear User Interface	COM 3: 100Mbps-T,RJ45/ 100Mbps-Fx,ST COM 2: RS-485 (2400bps to 57600bps)	100Mbps Copper/FO Ethernet port Serial RS485 port
SCADA Interface	IEC61850/DNP3 (Ethernet) 100 Mbps or Modbus (RS-485) or IEC 60870-5- 103(RS-485) or DNP3(RS-485)	Rear port
Time Sync	IRIG-B, BNC connector SNTP	Modulated or un-modulated
Self Checking/Relay Inoperative	2CO contact configurable	Closed NC when relay inoperative

F-PRO 235 Specifications		
Physical:		
Weight	4.50 Kgs	
Overall Dimensions	E6 case: 177mm(H) x 155mm(W) x 242.5mm(D)	
Cutout Dimensions – Flush Mount	E6 case : 159mm High x 150mm Wide	
Time Synchronization and Accuracy		
External Time Source	Synchronized using IRIG-B input (modulated or un-modulated) 1PPM SNTP	In the absence of an external time source, the relay maintains time with internal RTC. The relay can detect loss of re-establishment of external time source and automatically switch between internal and external time.
Overall F-PRO Accuracies		
Current	±2.5% of inputs from 0.1 to 1.0 x nominal current (I_n)	
	±1.0% of inputs from 1.0 to 4.0 x nominal current (I_n)	
Voltage	±1.0% of input of nominal voltage (V_n)	
Timers	±2.5 % of set value plus 1.00 to 1.50 cycles of inherent delay	
Inverse Overcurrent Timers	±2.5% or ±1 cycle of selected curve	
Definite Overcurrent Timers	±2.5% or ±1 cycle non-directional	
	±2.5% or ±1.5 cycle directional	

Detailed Environmental Tests

Standard	Description of the Test	Test Points	Test Level
IEC 60255-26:2013 Cl.No.7.2.3	Electrostatic Discharge	Enclosure Air Enclosure contact	+/- 8 kV +/- 6 kV
IEC 60255-26:2013 Cl.No.7.2.4	Radiated interference (Electromagnetic Field Immunity)	Enclosure ports	10 v/m : 80-1000 MHz : 1.4 GHz – 2.7 GHz
IEC 60255-26:2013 Cl.No.7.2.5	Electrical Fast Transient	AC/DC power ports AC voltage & current ports External I/P & O/P ports	+/- 4 kV
IEC 60255-26:2013 Cl.No.7.2.6	Slow Damped Oscillatory / High Frequency Disturbance / 1 MHz Burst Disturbance	AC/DC power ports AC voltage & current ports External I/P & O/P ports	+/- 2.5kV (CM) +/-1kV (DM)
IEC 60255-27:2013 Cl.No.10.6.4.2	Impulse Voltage	AC/DC power ports AC voltage & current ports External I/P & O/P ports	+/- 5 kV
IEC 60255-27:2013 Cl.No.10.6.4.3	AC Dielectric Voltage	AC/DC power ports AC voltage & current ports External I/P & O/P ports	2kV / min
IEC 60255-27:2013 Cl.No.10.6.4.4	Insulation Resistance Test	AC/DC power ports AC voltage & current ports External I/P & O/P ports	500V / min
IEC 60255-21-1 Class 1	Vibration		10Hz to 150Hz, 1.0g 1.0 Octave/min, 20 Sweep cycle/axis
IEC 60255-21-2 Class 1	Shock and Bump		5g and 15g
IEC 60255-21-3 Siesmic	Siesmic		5Hz to 35Hz, 1.0g 1.0 Octave/min, 1 Sweep cycle/axis

A.1 IDMTL Element Operating Time Curves

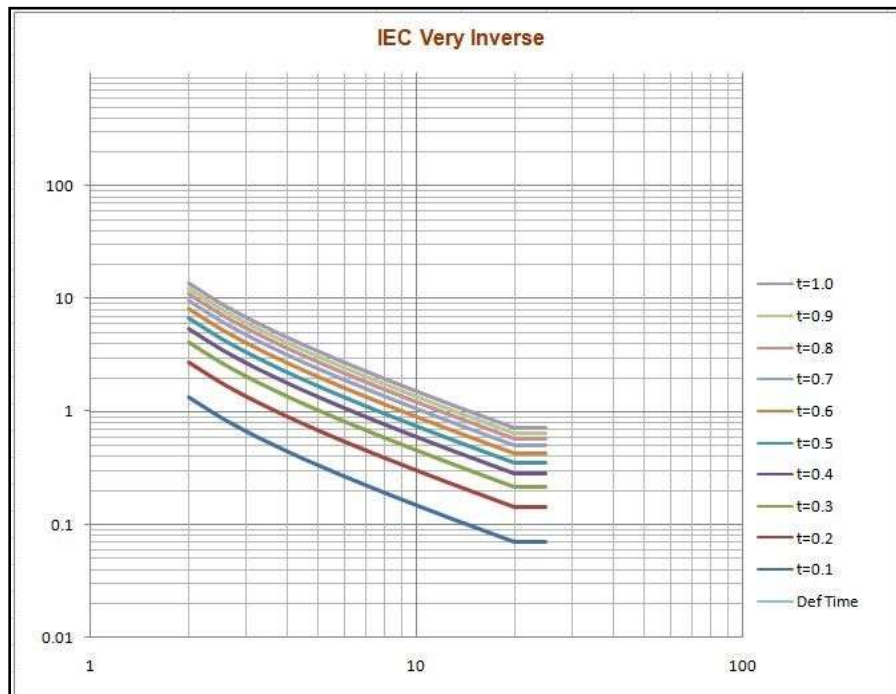

Figure A.1: IDMTL IEC very inverse curve

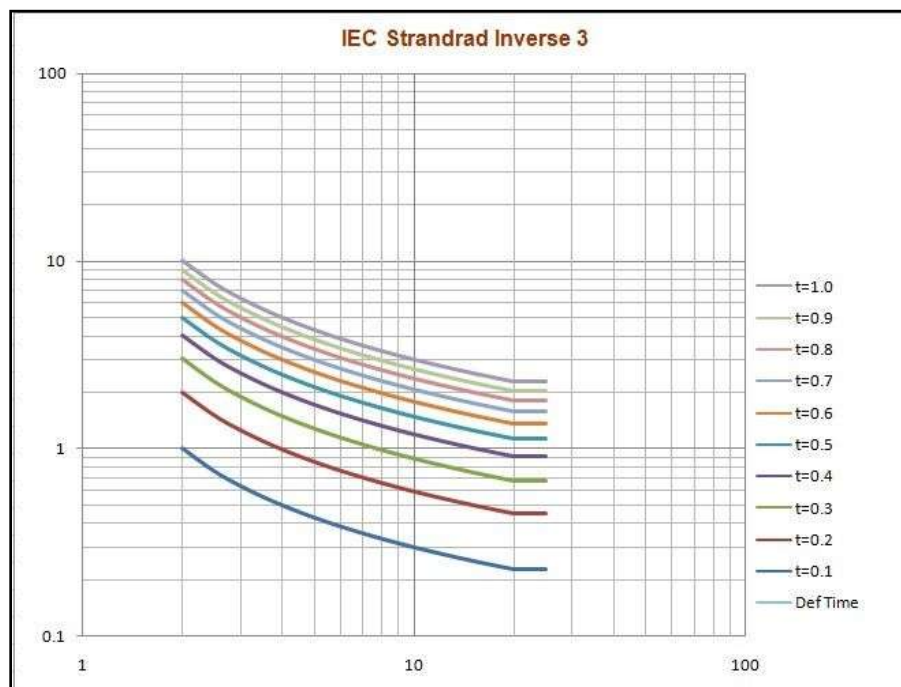

Figure A.2: IDMTL IEC Standard inverse curve 3

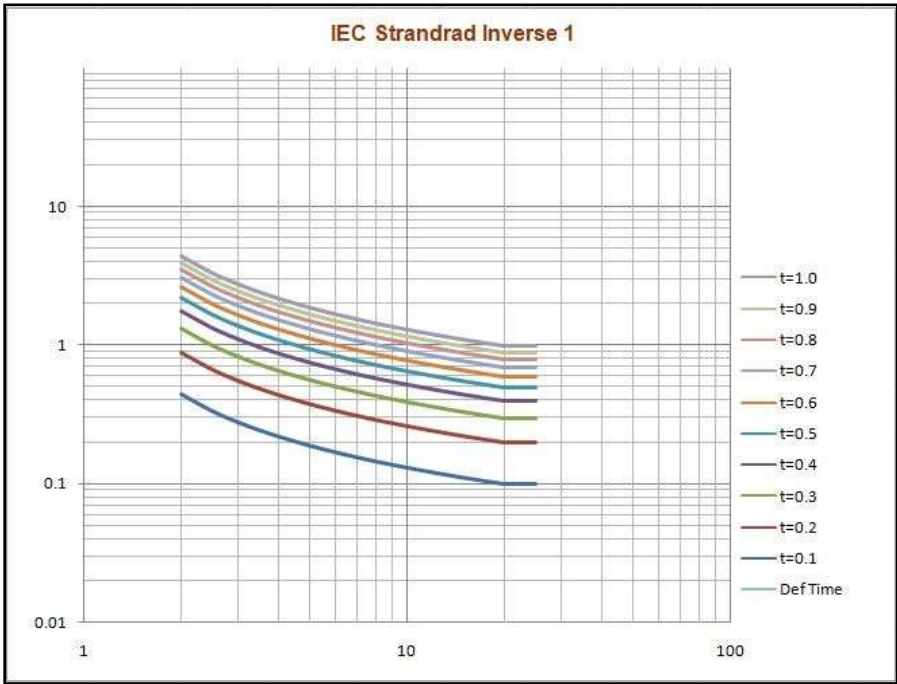

Figure A.3: IDMTL IEC Standard inverse curve 1

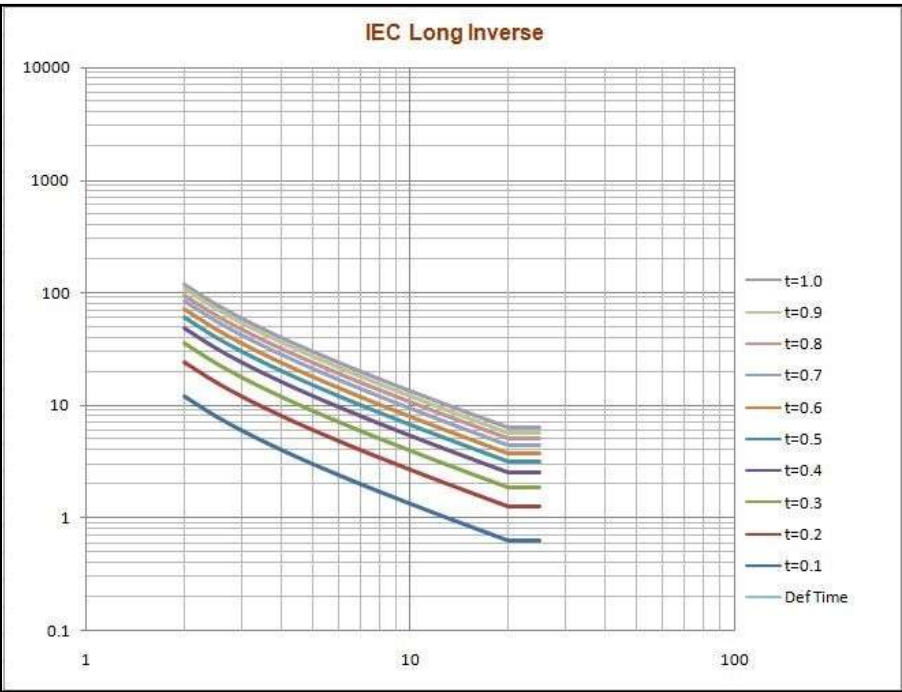

Figure A.4: IDMTL IEC Long inverse curve

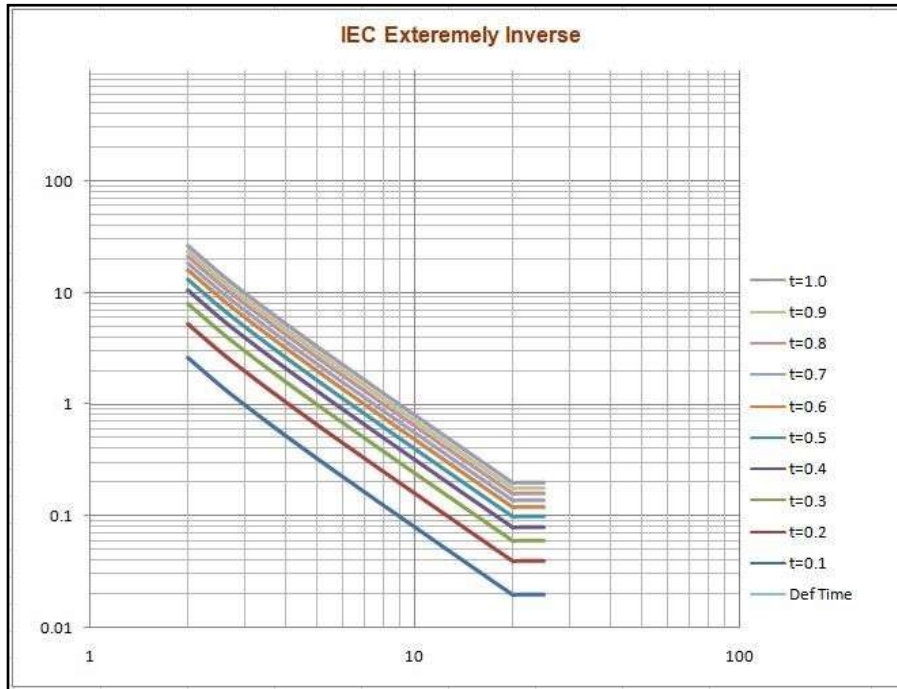

Figure A.5: IDMTL IEC Extremely inverse curve

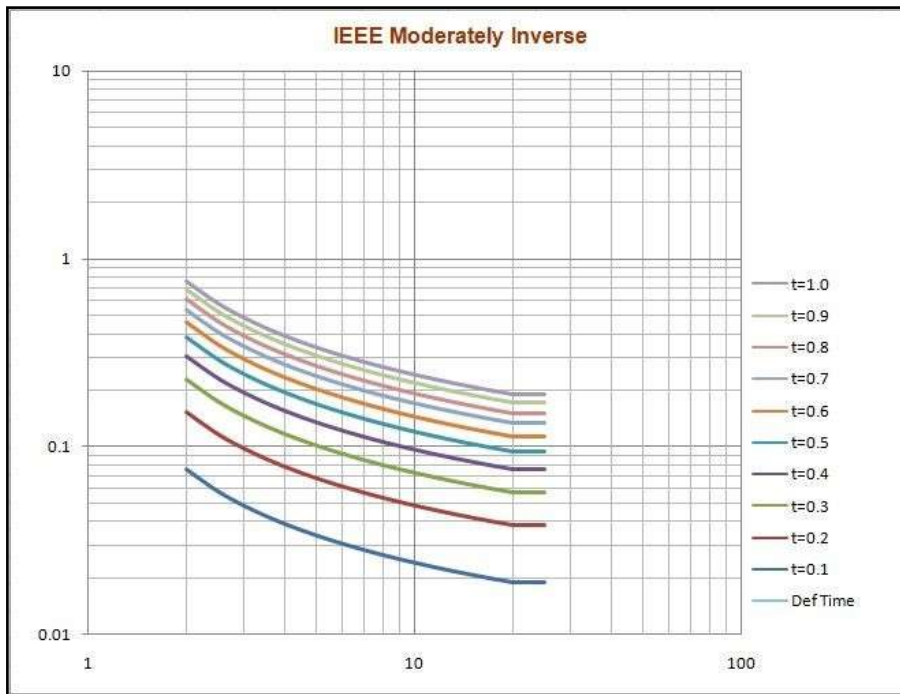

Figure A.6: IDMTL IEEE Moderately inverse curve

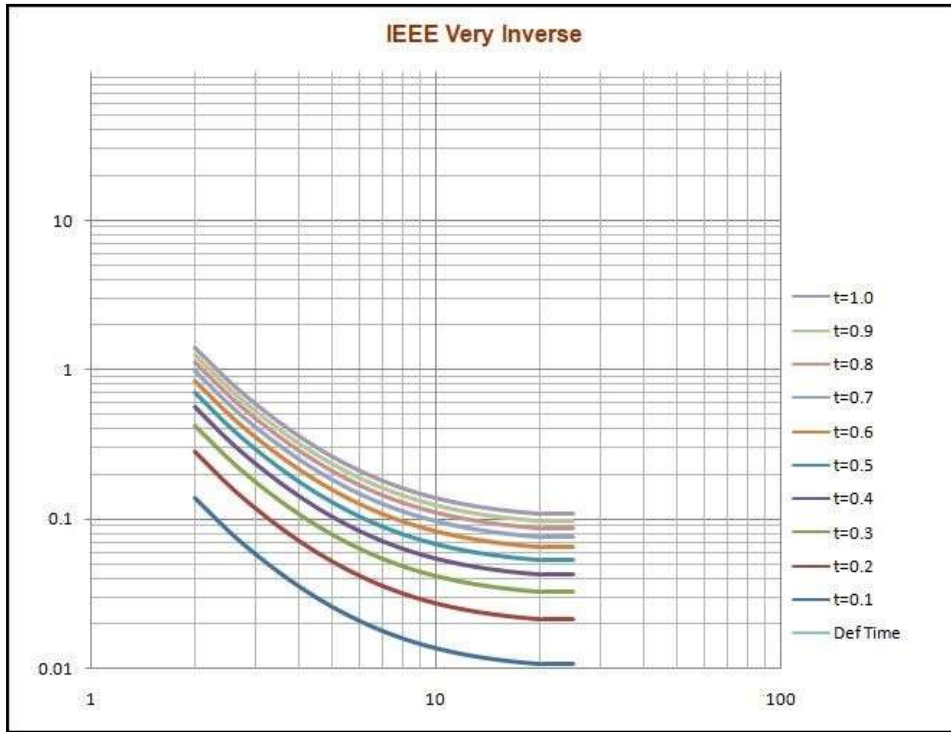

Figure A.7: IDMTL IEEE very inverse curve

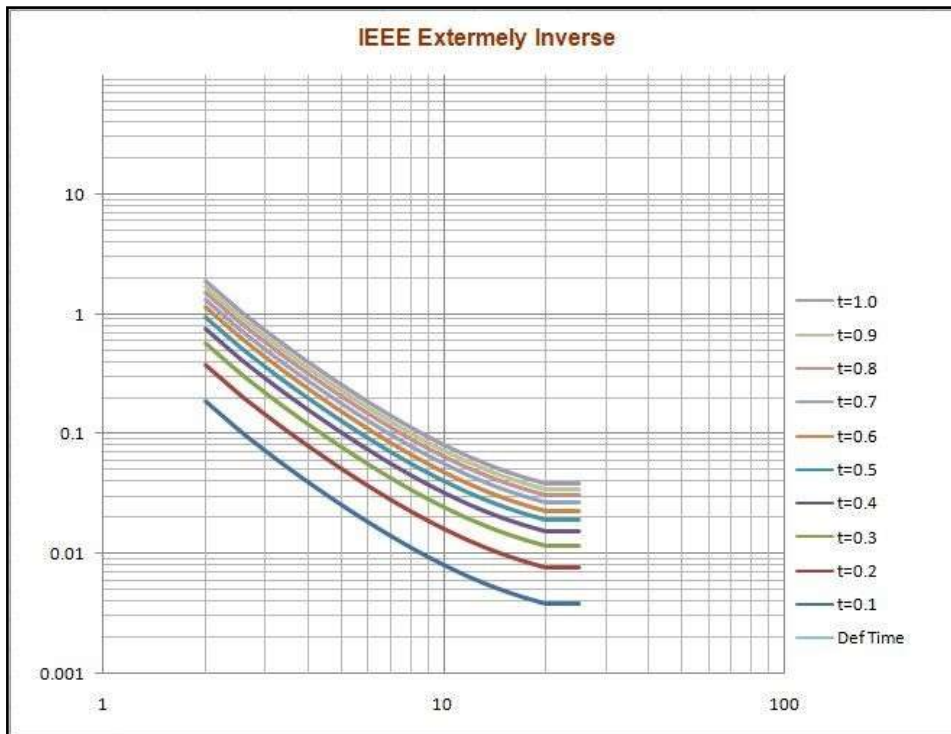

Figure A.8: IDMTL IEEE Extremely inverse curve

Appendix B IED Settings and Ranges

This topic describes the settings and its ranges of F-PRO 235 relay. When a setting has been completed in the F –PRO Offliner software, it can be printed along with the ranges available for these settings. This summary is however, a quick way of having a look at all the settings in a very compact form.

The top part of the settings summary identifies the date that the settings were done, the relay identification, the station that the relay is applied and location.

The setting summary provides a list of all the current and voltage analog input quantity names used for the protection and recording. External Inputs and Output are also identified on this summary.

F-PRO Settings Summary – Setting Group 1 [SG 1]			
Name	Symbol/Value	Unit	Range
Relay Identification			
Settings Version	5		
Ignore Serial Number	Yes		
Serial Number	FPRO-235		
Relay ID	RelayID		
Nominal System Frequency	50 Hz		
Standard I/O	4 External Inputs and 8 Output Contacts		
Comments	Comments		
Setting Name	Settings Name		
Date Created/Modified	2019-03-04 20:45:39		
Station Name	Station Name		
Location	Location		
Bay Name	Bay Name		

F-PRO Settings Summary – Setting Group 1 [SG 1]			
Name	Symbol/Value	Unit	Range
External Input Names			
EI 1	EI 1		
EI 2	EI 2		
EI 3	EI 3		
EI 4	EI 4		
Output Contact Names			
Output 1	RL 1		
Output 2	RL 2		
Output 3	RL 3		
Output 4	RL 4		
Output 5	RL 5		
Output 6	RL 6		
Output 7	RL 7		
Output 8	RL 8		
Virtual Input Names			
VI 1	VI 1		
VI 2	VI 2		
VI 3	VI 3		
VI 4	VI 4		
VI 5	VI 5		
VI 6	VI 6		
VI 7	VI 7		
VI 8	VI 8		

F-PRO Settings Summary – Setting Group 1 [SG 1]			
Name	Symbol/Value	Unit	Range
VI 9	VI 9		
VI 10	VI 10		
VI 11	VI 11		
VI 12	VI 12		
VI 13	VI 13		
VI 14	VI 14		
VI 15	VI 15		
VI 16	VI 16		
VI 17	VI 17		
VI 18	VI 18		
VI 19	VI 19		
VI 20	VI 20		
VI 21	VI 21		
VI 22	VI 22		
VI 23	VI 23		
VI 24	VI 24		
VI 25	VI 25		
VI 26	VI 26		
VI 27	VI 27		
VI 28	VI 28		
VI 29	VI 29		
VI 30	VI 30		

F-PRO Settings Summary – Setting Group 1 [SG 1]			
Name	Symbol/Value	Unit	Range
Setting Group Names			
Setting Group 1	SG 1		
Setting Group 2	SG 2		
Setting Group 3	SG 3		
Setting Group 4	SG 4		
System Parameters			
CT Configuration			
Phase CT Sec. current	1A		
Phase CT Ratio	100.0	-	1.0 to 30000.0
VT Configuration			
Phase VT Sec. voltage	63.5	V	40.0 to 160.0
Phase VT Ratio	1000.0	-	1.0 to 10000.0
Phase VT Secondary Connection	Ph-N		
Disturbance Record			
Record Length	1	s	1 to 20
Pre Trigger	0.25	s	0.10 to 0.50
Setting Group 1 [SG 1]			
Setting Group Comments: No Comments			
Protection Functions			
27/59DT-1	Enabled		
27/59DT-2	Enabled		
27/59DT-3	Enabled		
27/59DT-4	Disabled		
27/59DT-5	Disabled		
27/59DT-6	Disabled		

F-PRO Settings Summary – Setting Group 1 [SG 1]			
Name	Symbol/Value	Unit	Range
27/59IT-1	Enabled		
27/59IT-2	Disabled		
50/67-1	Enabled		
50/67-2	Disabled		
51/67-1	Enabled		
51/67-2	Disabled		
50N/67N-1	Enabled		
50N/67N-2	Disabled		
51N/67N-1	Enabled		
51N/67N-2	Disabled		
46/50	Enabled		
46/51	Enabled		
49	Enabled		
50BF	Enabled		
46BC	Enabled		
60CTS	Enabled		
60VTS	Enabled		
74TCS-1	Enabled		
74TCS-2	Enabled		
81HBL2	Enabled		
I^2t-CB	Enabled		
79	Enabled		

F-PRO Settings Summary – Setting Group 1 [SG 1]			
Name	Symbol/Value	Unit	Range
27/59DT – Phase Definite Time Under/Over Voltage			
27/59DT-1	Enabled		
Function Selection	UV		
Measurement Input	Fundamental		
Input Type	Ph-N		
Output Gate	AND		
Pickup V	51.0	V	3.0 to 250.0
Hysteresis	1	%	1 to 80
Pick DTL Delay	0.20	s	0.00 to 999.99
Reset DTL Delay	0.00	s	0.00 to 999.99
VTS Blocking	Disable		
27/59DT-2	Enabled		
Function Selection	OV		
Measurement Input	Fundamental		
Input Type	Ph-N		
Output Gate	AND		
Pickup V	51.0	V	3.0 to 250.0
Hysteresis	1	%	1 to 80
Pick DTL Delay	0.20	s	0.00 to 999.99
Reset DTL Delay	0.00	s	0.00 to 999.99
VTS Blocking	Disable		
27/59DT-3	Enabled		
Function Selection	UV		
Measurement Input	Fundamental		
Input Type	Ph-Ph		

F-PRO Settings Summary – Setting Group 1 [SG 1]			
Name	Symbol/Value	Unit	Range
Output Gate	AND		
Pickup V	51.0	V	3.0 to 250.0
Hysteresis	1	%	1 to 80
Pick DTL Delay	0.20	s	0.00 to 999.99
Reset DTL Delay	0.00	s	0.00 to 999.99
VTS Blocking	Disable		
27/59DT-4	Disabled		
27/59DT-5	Disabled		
27/59DT-6	Disabled		
27/59IT – Phase Inverse Time Under/Over Voltage			
27/59IT-1	Enabled		
Function Selection	UV		
Measurement Input	Fundamental		
Input Type	Ph-N		
Output Gate	AND		
Pickup V	55.0	V	3.0 to 250.0
Hysteresis	1	%	1 to 80
Curve Type	IEC Standard Inverse		
TMS	1.00	-	0.01 to 10.00
Pick DTL Delay	10.00	s	0.00 to 999.99
Reset DTL Delay	0.00	s	0.00 to 999.99
A	1.0	-	0.1 to 50.0
B	0.0	-	0.0 to 10.0
p	1.0	-	0.1 to 10.0
VTS Blocking	Disable		

F-PRO Settings Summary – Setting Group 1 [SG 1]			
Name	Symbol/Value	Unit	Range
27/59IT-2	Disabled		
67-Directional element for Phase Overcurrent			
Characteristic Angle	45	Deg	-95 to 95
Minimum Voltage	1.00	V	1.00 to 40.00
2 out of 3 Logic	Disabled		
VTS Blocking	Disabled		
67N-Directional element for Neutral Overcurrent			
Characteristic Angle	-45	Deg	-95 to 95
Minimum Voltage	0.30	V	0.30 to 40.00
Measurement Input	NPS		
VTS Blocking	Disabled		
50/67 – Instantaneous Phase Overcurrent			
50/67-1	Enabled		
Direction Selection	Non-Directional		
Pickup I>>	10.00	A	0.05 to 25.00
Pickup Delay	0.00	s	0.00 to 999.99
Inrush Block	Enabled		
50/67-2	Disabled		
51/67 – IDMTL Phase Overcurrent			
51/67-1	Enabled		
Direction Selection	Non-Directional		
Pickup I>	1.20	A	0.05 to 10.00
Curve Type	IEC standard inverse-3		
TMS	1.00	-	0.01 to 10.00

F-PRO Settings Summary – Setting Group 1 [SG 1]			
Name	Symbol/Value	Unit	Range
Pickup DTL Delay	10.00	s	0.00 to 999.99
Reset Delay	DTL		
Reset DTL Delay	0.0	s	0.0 to 99.9
A	0.1400	-	-
B	0.0000	-	-
p	0.02	-	-
Reset Delay(TR)	13.50	-	0.10 to 150.00
Inrush Block	Enabled		
51/67-2	Disabled		
50N/67N – Derived Instantaneous Neutral Overcurrent			
50N/67N-1	Enabled		
Direction Selection	Non-Directional		
Pickup IN>>	1.00	A	0.05 to 25.00
Pickup Delay	0.00	s	0.00 to 999.99
Inrush Block	Enabled		
50N/67N-2	Disabled		
51N/67N – Derived IDMTL Neutral Overcurrent			
51N/67N-1	Enabled		
Direction Selection	Non-Directional		

F-PRO Settings Summary – Setting Group 1 [SG 1]			
Name	Symbol/Value	Unit	Range
Pickup IN>	0.20	A	0.05 to 10.00
Curve Type	IEC standard inverse-3		
TMS	1.00	-	0.01 to 10.00
Pickup DTL Delay	10.00	s	0.00 to 999.99
Reset Delay	DTL		
Reset DTL Delay	0.0	s	0.0 to 99.9
A	0.1400	-	-
B	0.0000	-	-
p	0.02	-	-
Reset Delay(TR)	13.50	-	0.10 to 150.00
Inrush Block	Enabled		
51N/67N-2	Disabled		
46/50 – Instantaneous Negative Sequence Overcurrent			
46/50	Enabled		
Pickup I2>>	0.25	A	0.05 to 0.95
Pickup Delay	0.00	s	0.00 to 999.99
46/51 – IDMTL Negative Sequence Overcurrent			
46/51	Enabled		
Pickup I2>	0.25	A	0.05 to 0.95
Curve Type	IEC standard inverse		
TMS	1.00	-	0.01 to 10.00
Pickup DTL Delay	10.00	s	0.00 to 999.99
Reset Delay	ANSI Decay		

F-PRO Settings Summary – Setting Group 1 [SG 1]			
Name	Symbol/Value	Unit	Range
Reset DTL Delay	0.0	s	0.0 to 99.9
A	0.1400	-	-
B	0.0000	-	-
p	0.02	-	-
Reset Delay(TR)	13.50	-	0.10 to 150.00
49 – Thermal Overload			
49	Enabled		
Thermal Overload	1.05	A	0.20 to 2.00
Time Constant	10.00	min	0.50 to 100.00
Neg. Seq. Weighing Factor	0.00	-	0.00 to 10.00
Thermal OL Alarm	Enabled		
Pickup % Th	80	%	50 to 100
50BF – Breaker Failure Protection			
50BF	Enabled		
Pickup I>>	0.20	A	0.05 to 2.00
Pickup Delay 1	0.20	s	0.00 to 999.99
Pickup Delay 2	0.40	s	0.00 to 999.99
46BC – Broken Conductor			
46BC	Enabled		
Pickup I2/I1>	30.00	%	20.00 to 100.00
Pickup Delay	10.00	s	0.02 to 999.99
60CTS – CT Supervision			
60CTS	Enabled		
Vnps Pickup	20.00	V	7.00 to 110.00
Inps Pickup	0.10	A	0.05 to 1.00

F-PRO Settings Summary – Setting Group 1 [SG 1]			
Name	Symbol/Value	Unit	Range
Pickup Delay	10.00	s	0.03 to 999.99
60VTS – VT Supervision			
60VTS	Enabled		
I1 Blocking	1.5	A	0.1 to 10.0
3I0 Blocking	0.2	A	0.1 to 10.0
Negative Sequence Monitoring	Disabled		
Vnps	10.0	V	7.0 to 110.0
Inps	0.10	A	0.05 to 1.00
74TCS – Trip Circuit Supervision			
74TCS-1[TCS 1]	Enabled		
Drop off Delay	0.40	s	0.00 to 9.99
74TCS-2[TCS 2]	Enabled		
Drop off Delay	0.40	s	0.00 to 9.99
81HBL2 – Inrush			
81HBL2	Enabled		
Cross Blocking	Enabled		
Pickup I2nd>	15	%	5 to 50
I^2t-CB Condition			
I^2t-CB	Enabled		
I^2t Limit	99999.9	kA^2s	0.1 to 99999.9
79 – Recloser			
79	Enabled		
Number Of Shots	1	-	1 to 4
First Reclose – T1	1.00	s	0.10 to 999.99
Second Reclose – T2	5.00	s	1.00 to 999.99

F-PRO Settings Summary – Setting Group 1 [SG 1]			
Name	Symbol/Value	Unit	Range
Third Reclose – T3	10.00	s	1.00 to 999.99
Fourth Reclose – T4	20.00	s	1.00 to 999.99
Close Time – Tp	0.20	s	0.01 to 1.00
Reclaim Time – Td	25.00	s	0.00 to 999.99
Initiate Reset – TDI	1.00	s	0.00 to 999.99
Block Reset – TDB	0.50	s	0.00 to 999.99
PL 1 [ProLogic 1]			
ProLogic 1	Enabled		
Pickup Delay-Tp	0.00	s	0.00 to 999.00
Dropout Delay-Td	0.00	s	0.00 to 999.00
Operator 1			
Input A	<Unused = 0>		
Operator 2			
Input B	<Unused = 0>		
Operator 3			
Input C	<Unused = 0>		
Operator 4			
Input D	<Unused = 0>		
Operator 5			
Input E	<Unused = 0>		
PL 2 [ProLogic 2]			
ProLogic 2	Disabled		
PL 3 [ProLogic 3]			
ProLogic 3	Disabled		

F-PRO Settings Summary – Setting Group 1 [SG 1]			
Name	Symbol/Value	Unit	Range
PL 4 [ProLogic 4]			
ProLogic 4	Disabled		
PL 5 [ProLogic 5]			
ProLogic 5	Disabled		
PL 6 [ProLogic 6]			
ProLogic 6	Disabled		
PL 7 [ProLogic 7]			
ProLogic 7	Disabled		
PL 8 [ProLogic 8]			
ProLogic 8	Disabled		
PL 9 [ProLogic 9]			
ProLogic 9	Disabled		
PL 10 [ProLogic 10]			
ProLogic 10	Disabled		
PL 11 [ProLogic 11]			
ProLogic 11	Disabled		
PL 12 [ProLogic 12]			
ProLogic 12	Disabled		
PL 13 [ProLogic 13]			
ProLogic 13	Disabled		
PL 14 [ProLogic 14]			
ProLogic 14	Disabled		
PL 15 [ProLogic 15]			
ProLogic 15	Disabled		

F-PRO Settings Summary – Setting Group 1 [SG 1]			
Name	Symbol/Value	Unit	Range
PL 16 [ProLogic 16]			
ProLogic 16	Disabled		
PL 17 [ProLogic 17]			
ProLogic 17	Disabled		
PL 18 [ProLogic 18]			
ProLogic 18	Disabled		
PL 19 [ProLogic 19]			
ProLogic 19	Disabled		
PL 20 [ProLogic 20]			
ProLogic 20	Disabled		
Relay Reset			
Reset Type[RL 1]	Self Reset		
Minimum Energize Delay	0.10	s	-
Reset Type[RL 2]	Self Reset		
Minimum Energize Delay	0.10	s	0.00 to 1.00
Reset Type[RL 3]	Self Reset		
Minimum Energize Delay	0.10	s	0.00 to 1.00
Reset Type[RL 4]	Self Reset		
Minimum Energize Delay	0.10	s	0.00 to 1.00
Reset Type[RL 5]	Self Reset		
Minimum Energize Delay	0.10	s	0.00 to 1.00
Reset Type[RL 6]	Self Reset		
Minimum Energize Delay	0.10	s	0.00 to 1.00
Reset Type[RL 7]	Self Reset		
Minimum Energize Delay	0.10	s	0.00 to 1.00

F-PRO Settings Summary – Setting Group 1 [SG 1]			
Name	Symbol/Value	Unit	Range
Reset Type[RL 8]	Self Reset		
Target LED Reset			
Reset Type[Target LED 2]	Self Reset		Self / Hand Reset
Reset Type[Target LED 3]	Self Reset		Self / Hand Reset
Reset Type[Target LED 4]	Self Reset		Self / Hand Reset
Reset Type[Target LED 5]	Self Reset		Self / Hand Reset
Reset Type[Target LED 6]	Self Reset		Self / Hand Reset
Reset Type[Target LED 7]	Self Reset		Self / Hand Reset
Reset Type[Target LED 8]	Self Reset		Self / Hand Reset

Appendix C Hardware Description

The relay is designed and manufactured with high quality features and recording components for a complete feeder protection package. The following information describes the main hardware components of the relay

Fascia Board (FB):

The FB has System on Module and it contains high speed dual core processor which performs the entire relay operation. The FB is interfaced to Carrier Board, which manages the protection features of the relay. The dual core processor manages the user interface and system control features of the relay. It also has 5 keys (The keypad is used to navigate the menus on the display to control relay operation by a local user), 2 row X 16 character alphanumeric LCD, RTC backup battery, LED's and USB interface.

The FB provides the following functionality:

- DSP processor subsystem manages the protection features of the relay with the floating point arithmetic to provide fast capture and manipulation of data.
- ARM processor subsystem performs the post processing activity like disturbance recording, logging fault & event, communication protocol support, LCD HMI and PC interface activity.
- NOR and NAND Flash memory supports field software upgrades.
- Settings and records are stored in non-volatile memory.
- Runs on a Real Time Operating System (RTOS).
- Provides Ethernet ports, RS-485 port and USB interface.
- Time synchronism co-processor with modulated and un-modulated IRIG-B.
- High speed inbuilt link is provided between the DSP and ARM processor subsystems.
- Sophisticated fault detection.

Carrier Board (CB):

This board contains SMPS, 2 digital input channels (Inputs are optically isolated, externally wetted and ordering option with the voltage level of 24 / 48 / 110 / 220 Vdc selection), 4 normally open contact outputs, 1 form A contact output for relaying, alarms & control, RS485 interface, 5 channel analog input. This board is interfaced to the FB Board.

CB has 6 channel analog inputs (3 current transformer inputs and 3 voltage transformer inputs). It provides the analog to digital conversion of 5 ac analog current inputs. The sampling rate is fixed at 32 samples/cycle. Each channel is simultaneously sampled using 16-bit analog to digital converters. The digitized data is sent to the FB for processing of protection algorithms

SMPS provides the power supply for the entire unit. The switching frequency is 132 kHz and it reduces the transformer size with no noticeable impact on EMI, accurate programmable current limit, fully integrated soft-start for minimum start-up stress. The two power supply operating ranges are 20 – 60Vdc and 80 -300 Vdc, 100-240 Vac, +/-10%, 50/60 Hz. This wide operating range provides easier installation by eliminating power supply ordering options.

Add On Board:

This board contains 2 digital input channels(Inputs are optically isolated, externally wetted and ordering option with the voltage level of 24 / 48 / 110 / 220 Vdc selection),2 normally open contact outputs, 1 form A contact output for relaying, alarms & control, IRIG-B(Modulated and Un-modulated input selection through jumper) & 100Mbps Ethernet. This board is interfaced to the Carrier Board. SNTP Time sync is connected through Ethernet.

Appendix D Event Messages

Event Log Message	Notes
27DT-1 ABC Phase: Picked up	The possible phase information will be: <ul style="list-style-type: none"> • A • B • C • AB • BC • CA • ABC
27DT-2 ABC Phase: Picked up	
27DT-3 ABC Phase: Picked up	
27DT-4 ABC Phase: Picked up	
27DT-5 ABC Phase: Picked up	
27DT-6 ABC Phase: Picked up	
27DT-1 ABC Phase: Operated	
27DT-2 ABC Phase: Operated	
27DT-3 ABC Phase: Operated	
27DT-4 ABC Phase: Operated	
27DT-5 ABC Phase: Operated	
27DT-6 ABC Phase: Operated	
27IT-1 ABC Phase: Picked up	
27IT-2 ABC Phase: Picked up	
27IT-1 ABC Phase: Operated	
27IT-2 ABC Phase: Operated	
59DT-1 ABC Phase: Picked up	
59DT-2 ABC Phase: Picked up	
59DT-3 ABC Phase: Picked up	
59DT-4 ABC Phase: Picked up	
59DT-5 ABC Phase: Picked up	
59DT-6 ABC Phase: Picked up	
59DT-1 ABC Phase: Operated	
59DT-2 ABC Phase: Operated	
59DT-3 ABC Phase: Operated	
59DT-4 ABC Phase: Operated	
59DT-5 ABC Phase: Operated	
59DT-6 ABC Phase: Operated	
59IT-1 ABC Phase: Picked up	
59IT-2 ABC Phase: Picked up	
59IT-1 ABC Phase: Operated	
59IT-2 ABC Phase: Operated	

Event Log Message	Notes
50/67-1 ABC: Picked up	The possible phase information will be:
50/67-1 ABC: Operated	
50/67-2 ABC: Picked up	
50/67-2 ABC: Operated	
51/67-1 ABC: Picked up	
51/67-1 ABC: Operated	
51/67-2 ABC: Picked up	
51/67-2 ABC: Operated	
50N/67N-1 :Picked up	
50N/67N-1 : Operated	
50N/67N-2 :Picked up	
50N/67N-2 : Operated	
51N/67N-1 :Picked up	
51N/67N-1 : Operated	
51N/67N-2 :Picked up	
51N /67N-2: Operated	
60CTS operated	
60 VTS operated	
46/50: Picked up	
46/50: Operated	
46/51: Picked up	
46/51 : Operated	
49 ABC: Pickup	
49 ABC: Operated	
49 AL: Operated	
50BF-D1 Operated	
50BF-D2 Operated	
46BC Operated	
60 CTS Operated	
60 VTS Operated	
74TCS-1 Operated	
74TCS-2 Operated	

Event Log Message	Notes
81HBL2 Operated	The possible phase information will be:
79 IN	• A
79 OUT	• B
79 Reclose	• C
79 AR Initiate	• AB
79 Block	• BC
79 Lockout	• CA
I [^] 2T Limit Operated	• ABC
ProLogic Name: PL _n	ProLogic outputs names are user assigned (Where n=20)
Extern Input Name: EIn	External input names are user assigned (Where n = 8)
New Settings loaded, Active group n.	Where n = 1-4
Manual Settings Load request, activate SG _n	Where n = 1-4
Manual Settings Load request completed	Manual or user initiated settings change. (Only when settings loaded from HMI)
Changed Active Group from x to y	Completion of user initiated settings change.
Logic n	This happens when relay changes setting group. Automatic group logic initiated setting group change
User changed Active Group from x to y	This happens when the relay changes setting group. User initiated setting group change
Unit Recalibrated	
Unit restarted	

Appendix E Modbus RTU Communication Protocol

F-PRO COM 2 port supports IEC 103 and Modicon Modbus protocols. All metering values available through the terminal user interface are also available via the Modbus protocol. Additionally, the Modbus protocol support the reading of the unit time and time of the readings and provides access to trip, alarm events and also includes fault information.

A “Hold Readings” function is available to freeze all metering readings into a snapshot (see Force Single Coil function, address 0).

Table 13.1 Relay Coil Status (Function Code 1)			
Channel	Address	Value	
Hold Readings	1	0: Readings not held	1: Readings held
Reserved	257	Reserved	Reserved
27DT-1 Picked up	513	0: OFF	1: ON
27DT-2 Picked up	514	0: OFF	1: ON
27DT-3 Picked up	515	0: OFF	1: ON
27DT-4 Picked up	516	0: OFF	1: ON
27DT-5 Picked up	517	0: OFF	1: ON
27DT-6 Picked up	518	0: OFF	1: ON
27DT-1 Operated	519	0: OFF	1: ON
27DT-2 Operated	520	0: OFF	1: ON
27DT-3 Operated	521	0: OFF	1: ON
27DT-4 Operated	522	0: OFF	1: ON
27DT-5 Operated	523	0: OFF	1: ON
27DT-6 Operated	524	0: OFF	1: ON
27IT-1 Picked up	525	0: OFF	1: ON
27IT-2 Picked up	526	0: OFF	1: ON
27IT-1 Operated	527	0: OFF	1: ON
27IT-2 Operated	528	0: OFF	1: ON
59DT-1 Picked up	529	0: OFF	1: ON
59DT-2 Picked up	530	0: OFF	1: ON
59DT-3 Picked up	531	0: OFF	1: ON
59DT-4 Picked up	532	0: OFF	1: ON
59DT-5 Picked up	533	0: OFF	1: ON
59DT-6 Picked up	534	0: OFF	1: ON
59DT-1 Operated	535	0: OFF	1: ON
59DT-2 Operated	536	0: OFF	1: ON
59DT-3 Operated	537	0: OFF	1: ON
59DT-4 Operated	538	0: OFF	1: ON
59DT-5 Operated	539	0: OFF	1: ON
59DT-6 Operated	540	0: OFF	1: ON

Table 13.2 Relay Coil Status (Function Code 1)			
Channel	Address	Value	
59IT-1 Picked up	541	0: OFF	1: ON
59IT-2 Picked up	542	0: OFF	1: ON
59IT-1 Operated	543	0: OFF	1: ON
59IT -2 Operated	544	0: OFF	1: ON
50/67-1 Picked up	545	0: OFF	1: ON
50/67-2 Picked up	546	0: OFF	1: ON
50/67-1 Operated	547	0: OFF	1: ON
50/67-2 Operated	548	0: OFF	1: ON
51/67-1 Picked up	549	0: OFF	1: ON
51/67-2 Picked up	550	0: OFF	1: ON
51/67-1 Operated	551	0: OFF	1: ON
51/67-2 Operated	552	0: OFF	1: ON
50N/67N-1 Picked up	553	0: OFF	1: ON
50N/67N -2 Picked up	554	0: OFF	1: ON
50N/67N -1 Operated	555	0: OFF	1: ON
50N/67N -2 Operated	556	0: OFF	1: ON
51N/67N -1 Picked up	557	0: OFF	1: ON
51N/67N -2 Picked up	558	0: OFF	1: ON
51N/67N -1 Operated	559	0: OFF	1: ON
51N/67N -2 Operated	560	0: OFF	1: ON
46/50 Picked up	561	0: OFF	1: ON
46/50 Operated	562	0: OFF	1: ON
46/51 Picked up	563	0: OFF	1: ON
46/51 Operated	564	0: OFF	1: ON
49 Picked up	565	0: OFF	1: ON
49 Operated	566	0: OFF	1: ON
49AL Operated	567	0: OFF	1: ON
50BF-D1 Operated	568	0: OFF	1: ON
50BF- D2 Operated	569	0: OFF	1: ON
46BC Operated	570	0: OFF	1: ON
74TCS-1 Operated	571	0: OFF	1: ON
74TCS-2 Operated	572	0: OFF	1: ON
81HBL2 Operated	573	0: OFF	1: ON
79 IN	574	0: OFF	1: ON
79 OUT	575	0: OFF	1: ON
79 Reclose	576	0: OFF	1: ON
79 AR Initiate	577	0: OFF	1: ON
79 Block	578	0: OFF	1: ON
79 Lockout	579	0: OFF	1: ON
I2t Limit Operated	580	0: OFF	1: ON
60CTS Operated	581	0: OFF	1: ON
60VTS Operated	582	0: OFF	1: ON

Table 13.3 Read Coil Status (Function Code 01)			
Channel	Address	Value	
ProLogic1	583	0: OFF	1: ON
ProLogic2	584	0: OFF	1: ON
ProLogic3	585	0: OFF	1: ON
ProLogic4	586	0: OFF	1: ON
ProLogic5	587	0: OFF	1: ON
ProLogic6	588	0: OFF	1: ON
ProLogic7	589	0: OFF	1: ON
ProLogic8	590	0: OFF	1: ON
ProLogic9	591	0: OFF	1: ON
ProLogic10	592	0: OFF	1: ON
ProLogic11	593	0: OFF	1: ON
ProLogic12	594	0: OFF	1: ON
ProLogic13	595	0: OFF	1: ON
ProLogic14	596	0: OFF	1: ON
ProLogic15	597	0: OFF	1: ON
ProLogic16	598	0: OFF	1: ON
ProLogic17	599	0: OFF	1: ON
ProLogic18	600	0: OFF	1: ON
ProLogic19	601	0: OFF	1: ON
ProLogic20	602	0: OFF	1: ON
Relay O/P1	603	0: OFF	1: ON
Relay O/P2	604	0: OFF	1: ON
Relay O/P3	605	0: OFF	1: ON
Relay O/P4	606	0: OFF	1: ON
Relay O/P5	607	0: OFF	1: ON
Relay O/P6	608	0: OFF	1: ON
Relay O/P7	609	0: OFF	1: ON
Relay O/P8	610	0: OFF	1: ON

Table 13.4 Read Discrete Inputs (Function Code 02)			
Channel	Address	Value	
Status I/P 1- Present state	10001	0: OFF	1: ON
Status I/P 2- Present state	10002	0: OFF	1: ON
Status I/P 3- Present state	10003	0: OFF	1: ON
Status I/P 4- Present state	10004	0: OFF	1: ON

Table 13.5 Read Discrete Inputs (Function Code 02)			
Channel	Address	Value	
Status I/P 1- Change of state	10257	0: OFF	1: ON
Status I/P 2- Change of state	10258	0: OFF	1: ON
Status I/P 3- Change of state	10259	0: OFF	1: ON
Status I/P 4- Change of state	10260	0: OFF	1: ON
Virtual Input1	10513	0: OFF	1: ON
Virtual Input2	10514	0: OFF	1: ON
Virtual Input3	10515	0: OFF	1: ON
Virtual Input4	10516	0: OFF	1: ON
Virtual Input5	10517	0: OFF	1: ON
Virtual Input6	10518	0: OFF	1: ON
Virtual Input7	10519	0: OFF	1: ON
Virtual Input8	10520	0: OFF	1: ON
Virtual Input9	10521	0: OFF	1: ON
Virtual Input10	10522	0: OFF	1: ON
Virtual Input11	10523	0: OFF	1: ON
Virtual Input12	10524	0: OFF	1: ON
Virtual Input13	10525	0: OFF	1: ON
Virtual Input14	10526	0: OFF	1: ON
Virtual Input15	10527	0: OFF	1: ON
Virtual Input16	10528	0: OFF	1: ON
Virtual Input17	10529	0: OFF	1: ON
Virtual Input18	10530	0: OFF	1: ON
Virtual Input19	10531	0: OFF	1: ON
Virtual Input20	10532	0: OFF	1: ON
Virtual Input21	10533	0: OFF	1: ON
Virtual Input22	10534	0: OFF	1: ON
Virtual Input23	10535	0: OFF	1: ON
Virtual Input24	10536	0: OFF	1: ON
Virtual Input25	10537	0: OFF	1: ON
Virtual Input26	10538	0: OFF	1: ON
Virtual Input27	10539	0: OFF	1: ON
Virtual Input28	10540	0: OFF	1: ON
Virtual Input29	10541	0: OFF	1: ON
Virtual Input30	10542	0: OFF	1: ON

Table 13.6 Read Holding Registers (Function Code 03)			
Channel	Address	Units	Scale
VA Magnitude	40257	kV	100
VA Angle	40258	Degrees	1
VB Magnitude	40259	kV	100
VB Angle	40260	Degrees	1
VC Magnitude	40261	kV	100
VC Angle	40262	Degrees	1
VN Magnitude	40263	kV	100
VN Angle	40264	Degrees	1
IA Magnitude	40265	A	100
IA Angle	40266	Degrees	1
IB Magnitude	40267	A	100
IB Angle	40268	Degrees	1
IC Magnitude	40269	A	100
IC Angle	40270	Degrees	1
IN Magnitude	40271	A	100
IN Angle	40272	Degrees	1
V1 Magnitude	40273	kV	100
V2 Magnitude	40274	kV	100
V0 Magnitude	40275	kV	100
I1 Magnitude	40276	A	100
I2 Magnitude	40277	A	100
I0 Magnitude	40278	A	100
Frequency	40281	Hz	10
Power Factor	40282	-	100
Thermal state (%)	40283	%	100
I^2t Accumulated	40284	kA^2s	1
I^2t for last operation	40285	kA^2s	1

Note: In the above table, Scale value should be divided with the metering data obtained from Modbus.

Table 13.7 Read Holding Registers (Function Code 03)			
Channel	Address	Units	Scale
<i>F-PRO Clock Time (UTC) – Note: Read all in same query to ensure consistent time reading data</i>			
Milliseconds now	40001	0 – 999	1
Seconds now	40002	0 – 59	1
Minutes now	40003	0 – 59	1
Hours now	40004	0 – 23	1
Day of year now	40005	1 – 365	1
Year since 1900	40006	90 – 137	1
Synchronized to IRIG-B	40007	0: No & 1: Yes	1
<i>Time of Acquisition (UTC) – Note: Read all in same query to ensure consistent time reading data</i>			
Milliseconds now	40008	0 – 999	1
Seconds now	40009	0 – 59	1
Minutes now	40010	0 – 59	1
Hours now	40011	0 – 23	1
Day of year now	40012	1 – 365	1
Year since 1900	40013	90 – 137	1
Time Synchronization	40014	0: No Sync , 1: IRIG-B Sync & 2:SNTP Sync	1
Local time offset	40015	2's compliment half hours, North America is negative	1

Table 13.8 Write Single Coil (Function Code 05)			
Only the “hold readings” coil can be forced. When active, this coil locks all coil, input and holding register readings simultaneously at their present values. When inactive, coil, input and holding register values will read their most recently available state.			
Channel	Type	Address	Value
Hold Readings	Read/Write	01	0000: Readings update normally (inactive) FF00: Hold readings (active)

Table 13.9 Write Single Register (Function Code 06)			
Channel	Address	Value	Scaled Up By
<i>Event Message Control (See given below tables for details of use)</i>			
Refresh event list	40513	No data required	Not Applicable
Acknowledge the current event and get the next event	40514	No data required	Not Applicable
Get the next event (without acknowledge)	40515	No data required	Not Applicable

Table 13.10 Diagnostic Sub functions (Function Code 08)	
Return Query Data (Subfunction00)	This provides an echo of the submitted message.
Restart Communication Option (Subfunction01)	This restarts the Modbus communications process.
Force Listen Only Mode (Subfunction04)	No response is returned. IED enters "Listen Only" mode. This mode can only be excited by the "Restart Communication Option" command.

Table 13.11 Write Multiple Registers (Function Code 16)			
Channel	Address	Units	Scale
<i>F-PRO Clock Time (UTC) – Note: Must write to all the registers in same query</i>			
Milliseconds now	40001	0 – 999	1
Seconds now	40002	0 – 59	1
Minutes now	40003	0 – 59	1
Hours now	40004	0 – 23	1
Day of year now	40005	1 – 365	1
Year since 1900	40006	90 – 137	1

Table 13.11 Report Slave ID (Function Code 17)			
A fixed response is returned by the IED, including system model, version and issue numbers.			
Channel	Type	Bytes	Value
Model Number	Read Only	0 and 1	0 x 00Eb = 235 decimal
Version Number	Read Only	2 and 3	Version number
Issue Number	Read Only	4 and 5	Issue number

- The F-PRO IED model number is 235.
- Version and issue will each be positive integers, say X and Y.

Table 13.12 Accessing F-PRO Event Information	
All F-PRO detector event messages displayed in the Event Log are available via Modbus. The following controls are available.	
Refresh Event List	(Function Code 6, address 40513): Fetches the latest events from the F-PRO's event log and makes them available for Modbus access. The most recent event becomes the current event available for reading.
Acknowledge Current Event and Get Next Event	(Function Code 6, address 40514): Clears the current event from the read registers and places the next event into them. An acknowledged event is no longer available for reading.
Get Next Event	(Function Code 6, address 40515): Places the next event in the read registers without acknowledging the current event. The current event will reappear in the list when Refresh Event List is used.
Size of Current Event Message	(Function Code 3, address 40516): Indicates the number of 16 bit registers used to contain the current event. Event data is stored with two characters per register. A reading of zero indicates that there are no unacknowledged events available in the current set. (Note: The Refresh Event List function can be used to check for new events that have occurred since the last Refresh Event List.)
Read Event Message	(Function Code 3, addresses 40517 – 40576): Contains the current event message. Two ASCII characters are packed into each 16 bit register. All unused registers in the set are set to 0.

Table 13.13 Sample Event Record			
Register	Value		Meaning
	High Byte	Low Byte	
40516	0x00	0x14	Event text size = 20 (0x14 hex)
40517	0x32	0x30	'2', '0'
40518	0x31	0x33	'1', '3'
40519	0x53	0x65	'S', 'e'
40520	0x70	0x31	'p', '1'
40521	0x32	0x20	'2', ''
40522	0x30	0x38	'0', '8'
40523	0x3A	0x31	':', '1'
40524	0x36	0x3A	'6', ':'
40525	0x31	0x36	'1', '6'
40526	0x2E	0x39	':', '9'
40527	0x36	0x36	'6', '6'
40528	0x20	0x3A	'' , ':'
40529	0x20	0x35	'' , '5'
40530	0x30	0x2D	'0', '-'
40531	0x31	0x65	'1', 'A'
40532	0x66	0x20	'B', ''
40533	0x4F	0x70	'O', 'p'
40534	0x65	0x72	'e', 'r'
40535	0x61	0x74	'a', 't'
40536	0x65	0x64	'e', 'd'

Appendix F IEC 103 Device Profile

Device Properties

This document shows the device capabilities and the analog value of each parameter in IEC 103 nodes.

IEC60870-5-103 Function Type & COT Descriptions

Function Type	Description
160	IEC Overcurrent Protection
164	ERL Overcurrent Protection
165	ERL Voltage Protection
166	ERL Frequency Protection
167	ERL Synchronizing Function
168	ERL High Impedance Differential Protection
169	ERL Motor Protection
170	ERL Capacitor Protection
176	IEC Transformer Protection
178	ERL Transformer Protection
254	IEC Generic
255	IEC Global

Cause of Transmission (COT)	Description
1	Spontaneous Events
2	Cyclic
3	Reset Frame Count Bit (FCB)
4	Reset Communication Unit (CU)
5	Start Restart
8	Time Synchronization
9	General Interrogation
10	Termination of General Interrogation
11	Local Operation
12	Remote Operation
20	Positive Command Acknowledge
21	Negative Command Acknowledge

This section contains the event & command codes defined in IEC60870-5-103 section 7.2.5.2

KEY:-

FUN Function Type (defined in [1] IEC60870-5-103 section 7.2.5.1)

INF Information Number (defined in [1] IEC60870-5-103 section 7.2.5.2)

GI	Event supports General Interrogation x = supported (defined in [1] IEC60870-5-103 section 7.2.5.2)
TYP	ASDU Type (defined in [1] IEC60870-5-103 sections 7.3.1 and 7.3.2)
COT	Cause of Transmission (defined in [1] IEC60870-5-103 section 7.2.3, table 5)
DIR	Direction of event Raised Only (RO), Raised / Cleared (RC) or Double Point Travelling, Cleared, Raised or Unknown (DP)
x	Supported
-	Not supported

FUN	INF	Description	GI	TYP	COT	DIR
160	2	Reset FCB	-	5	3	RO
160	3	Reset CU	-	5	4	RO
160	4	Start/Restart	-	5	5	RO
160	5	Power ON	-	5	6	RO
160	16	ARC in progress	x	1	1, 9	RC
160	19	LEDs reset	-	1	1, 11, 12, 20, 21	RO
160	22	Settings changed	x	1	1, 9, 11, 12	RC
160	23	Setting G1 selected	x	1	1, 9, 11, 12, 20, 21	RC
160	24	Setting G2 selected	x	1	1, 9, 11, 12, 20, 21	RC
160	25	Setting G3 selected	x	1	1, 9, 11, 12, 20, 21	RC
160	26	Setting G4 selected	x	1	1, 9, 11, 12, 20, 21	RC
160	27	External Input1	x	1	1, 9	RC
160	28	External Input2	x	1	1, 9	RC
160	29	External Input3	x	1	1, 9	RC
160	30	External Input4	x	1	1, 9	RC
160	36	Trip Circuit Supervision (TCS-1)	x	1	1,9	RC
160	64	A-Starter	x	2	1, 9	RC
160	65	B-Starter	x	2	1, 9	RC
160	66	C-Starter	x	2	1, 9	RC
160	67	E-Starter	x	2	1, 9	RC
160	68	General trip	-	2	1	RO
160	69	A-General trip	-	2	1	RO
160	70	B-General trip	-	2	1	RO
160	71	C-General trip	-	2	1	RO
160	84	General starter	x	2	1,9	RC
160	85	Circuit Breaker Fail (50BF)	-	2	1	RO

160	91	P/F-General HS trip (50/67)	-	2	1	RO
160	92	E/F-General trip	-	2	1	RO
160	93	E/F-General HS trip (50N/67N)	-	2	1	RO
160	128	CB on by Auto-reclose	x	1	1,9	RC
160	130	Reclose Blocked	x	1	1,9	RC
160	148	Measurand IL1,2,3, VL1,2,3, P,	x	9	2	-
164	160	27DT-1 Picked up	-	2	1	RC
164	161	27DT-2 Picked up	-	2	1	RC
164	162	27DT-3 Picked up	-	2	1	RC
164	163	27DT-4 Picked up	-	2	1	RC
164	164	27DT-5 Picked up	-	2	1	RC
164	165	27DT-6 Picked up	-	2	1	RC
164	166	27DT-1 Operated	-	2	1	RO
164	167	27DT-2 Operated	-	2	1	RO
164	168	27DT-3 Operated	-	2	1	RO
164	169	27DT-4 Operated	-	2	1	RO
164	170	27DT-5 Operated	-	2	1	RO
164	171	27DT-6 Operated	-	2	1	RO
164	172	27IT-1 Picked up	-	2	1	RC
164	173	27IT-2 Picked up	-	2	1	RC
164	174	27IT-1 Operated	-	2	1	RO
164	175	27IT-2 Operated	-	2	1	RO
164	176	59DT-1 Picked up	-	2	1	RC
164	177	59DT-2 Picked up	-	2	1	RC
164	178	59DT-3 Picked up	-	2	1	RC
164	179	59DT-4 Picked up	-	2	1	RC
164	180	59DT-5 Picked up	-	2	1	RC
164	181	59DT-6 Picked up	-	2	1	RC

FUN	INF	Description	GI	TYP	COT	DIR
164	182	59DT-1 Operated	-	2	1	RO
164	183	59DT-2 Operated	-	2	1	RO
164	184	59DT-3 Operated	-	2	1	RO
164	185	59DT-4 Operated	-	2	1	RO
164	186	59DT-5 Operated	-	2	1	RO
164	187	59DT-6 Operated	-	2	1	RO
164	188	59IT-1 Picked up	-	2	1	RC
164	189	59IT-2 Picked up	-	2	1	RC
164	190	59IT-1 Operated	-	2	1	RO
164	191	59IT-2 Operated	-	2	1	RO
164	192	50/67-1 Picked up	-	2	1	RC
164	193	50/67-2 Picked up	-	2	1	RC
164	194	50/67-1 Operated	-	2	1	RO
164	195	50/67-2 Operated	-	2	1	RO
164	196	51/67-1 Picked up	-	2	1	RC
164	197	51/67-1 Operated	-	2	1	RO
164	198	50N/67N-1 Picked up	-	2	1	RC
164	199	50N/67N-2 Picked up	-	2	1	RC
164	200	50N/67N-1 Operated	-	2	1	RO
164	201	50N/67N-2 Operated	-	2	1	RO
164	202	51N/67N-1 Picked up	-	2	1	RC
164	203	51N/67N-1 Operated	-	2	1	RO
164	204	46/50 Picked up	-	2	1	RC
164	205	46/50 Operated	-	2	1	RO
164	206	46/51 Picked up	-	2	1	RC
164	207	46/51 Operated	-	2	1	RO
164	208	49 Picked up	-	2	1	RC
164	209	49 Operated	-	2	1	RO
164	210	49AL Operated	-	2	1	RO
164	211	50BF-D1 Operated	-	2	1	RO
164	212	50BF-D2 Operated	-	2	1	RO
164	213	46BC Operated	-	1	1	RO
164	214	I2t Limit Operated	-	1	1	RO
164	215	81HBL2 Operated	-	1	1	RO
164	216	60CTS Operated	-	1	1	RO
164	217	60VTS Operated	-	1	1	RO
164	218	51/67-2 Picked up	-	2	1	RC
164	219	51/67-2 Operated	-	2	1	RO
164	220	51N/67N-2 Picked up	-	2	1	RC
164	221	51N/67N-2 Operated	-	2	1	RO
164	222	Trip Circuit Supervision (TCS-2)	x	1	1,9	RC

FUN	INF	Description	GI	TYP	COT	DIR
164	223	Output1	x	1	1, 9, 12, 20, 21	RC
164	224	Output2	x	1	1, 9, 12, 20, 21	RC
164	225	Output3	x	1	1, 9, 12, 20, 21	RC
164	226	Output4	x	1	1, 9, 12, 20, 21	RC
164	227	Output5	x	1	1, 9, 12, 20, 21	RC
164	228	Output6	x	1	1, 9, 12, 20, 21	RC
164	229	Output7	x	1	1, 9, 12, 20, 21	RC
164	230	Output8	x	1	1, 9, 12, 20, 21	RC
164	231	Disturbance record stored	-	1	1, 12, 20, 21	RO
164	241	I _A Fault current	x	4	1,9	-
164	242	I _B Fault current	x	4	1,9	-
164	243	I _C Fault current	x	4	1,9	-
164	244	I _N Fault current	x	4	1,9	-
164	247	V _A Fault Voltage	x	4	1,9	-
164	248	V _B Fault Voltage	x	4	1,9	-
164	249	V _C Fault Voltage	x	4	1,9	-
164	250	V _N Fault Voltage	x	4	1,9	-
164	251	IRIG_B Synchronization	x	1	1,9	RC
164	252	SNTP Synchronization	x	1	1,9	RC
255	0	Time Synchronization	-	6	8	-

Appendix G DNP3.0 Device Profile

Device

Properties

This document shows the device capabilities and the current value of each parameter for the default unit configuration as defined in the default configuration file.

1.1 DEVICE IDENTIFICATION	Capabilities	Current Value	If configurable, list methods
1.1.1 Device Function:	0. Master 1. Outstation	Outstation	
1.1.2 Vendor Name:		ERL	
1.1.3 Device Name:		F-PRO235	
1.1.4 Device manufacturer's hardware version string:		v1.0	
1.1.5 Device manufacturer's software version string:		V2.6	
1.1.6 Device Profile Document Version Number:		V1.0., Feb13, 2019	
1.1.7 DNP Levels Supported for:	<p>Masters Only</p> <p>Requests Responses</p> <p><input type="checkbox"/> <input type="checkbox"/> None</p> <p><input type="checkbox"/> <input type="checkbox"/> Level 1</p> <p><input type="checkbox"/> <input type="checkbox"/> Level 2</p> <p><input type="checkbox"/> <input type="checkbox"/> Level 3</p> <p>Outstations Only</p> <p>Requests and Responses</p> <p><input type="checkbox"/> None</p> <p><input type="checkbox"/> Level 1</p> <p><input checked="" type="checkbox"/> Level 2</p> <p><input type="checkbox"/> Level 3</p>		
1.1.8 Supported Function Blocks:	<p><input type="checkbox"/> Self-Address Reservation</p> <p><input type="checkbox"/> <input type="checkbox"/> Object 0 – attribute objects</p> <p><input type="checkbox"/> Data Sets</p> <p><input type="checkbox"/> File Transfer</p> <p><input type="checkbox"/> Virtual Terminal</p> <p><input type="checkbox"/> Mapping to IEC 61850 Object Models defined in a DNP3 XML file</p>		

<p>1.1.9 Notable Additions:</p>	<ol style="list-style-type: none"> 1. Start-stop (qualifier codes 0x00 and 0x01), limited quantity (qualifier codes 0x07 and 0x08) and indices (qualifier codes 0x17 and 0x28) for Binary Inputs, Binary Outputs and Analog Inputs (object groups 1, 10 and 30) 2. 32-bit and 16-bit Analog Inputs with and without flag (variations 1, 2, 3 and 4) 3. 2-bit and 16-bit Analog Input events with time (variations 3 and 4) 		
<p>1.1.10 Methods to set Configurable Parameters:</p>	<ul style="list-style-type: none"> <input type="checkbox"/> XML – Loaded via DNP3 File Transfer <input type="checkbox"/> XML – Loaded via other transport mechanism <input type="checkbox"/> Terminal – ASCII Terminal Command Line <input checked="" type="checkbox"/> Software – Vendor software named <u>F-PRO 2000 Offliner</u> <input type="checkbox"/> Proprietary file loaded via DNP3 file transfer <input type="checkbox"/> Proprietary file loaded via other transport mechanism <input type="checkbox"/> Direct – Keypad on device front panel <input type="checkbox"/> Factory – Specified when device is ordered <input type="checkbox"/> Protocol – Set via DNP3 (e.g. assign class) <input type="checkbox"/> Other – explain 		

1.1.11 DNP3 XML files available On-Line:	<table border="1"> <thead> <tr> <th>Rd</th> <th>Wr</th> <th>Filename</th> <th>Description of Contents</th> </tr> </thead> <tbody> <tr> <td><input type="checkbox"/></td> <td></td> <td>dnpDP.xml</td> <td>Complete Device Profile</td> </tr> <tr> <td><input type="checkbox"/></td> <td></td> <td>dnpDPcap.xml</td> <td>Device Profile Capabilities</td> </tr> <tr> <td><input type="checkbox"/></td> <td></td> <td>dnpDPcfg.xml</td> <td>Device Profile config. values</td> </tr> <tr> <td><input type="checkbox"/></td> <td><input type="checkbox"/></td> <td>_____*.xml</td> <td></td> </tr> </tbody> </table> <p>_____</p> <ul style="list-style-type: none"> * The Complete Device Profile Document contains the capabilities, Current Value, and configurable methods columns. * The Device Profile Capabilities contains only the capabilities and configurable methods columns. * The Device Profile Config. Values contains only the Current Value column. 	Rd	Wr	Filename	Description of Contents	<input type="checkbox"/>		dnpDP.xml	Complete Device Profile	<input type="checkbox"/>		dnpDPcap.xml	Device Profile Capabilities	<input type="checkbox"/>		dnpDPcfg.xml	Device Profile config. values	<input type="checkbox"/>	<input type="checkbox"/>	_____*.xml		Not supported	
Rd	Wr	Filename	Description of Contents																				
<input type="checkbox"/>		dnpDP.xml	Complete Device Profile																				
<input type="checkbox"/>		dnpDPcap.xml	Device Profile Capabilities																				
<input type="checkbox"/>		dnpDPcfg.xml	Device Profile config. values																				
<input type="checkbox"/>	<input type="checkbox"/>	_____*.xml																					
1.1.12 External DNP3 XML files available Off-line:	<table border="1"> <thead> <tr> <th>Rd</th> <th>Wr</th> <th>Filename</th> <th>Description of Contents</th> </tr> </thead> <tbody> <tr> <td><input type="checkbox"/></td> <td><input type="checkbox"/></td> <td>dnpDP.xml</td> <td>Complete Device Profile</td> </tr> <tr> <td><input type="checkbox"/></td> <td><input type="checkbox"/></td> <td>dnpDPcap.xml</td> <td>Device Profile Capabilities</td> </tr> <tr> <td><input type="checkbox"/></td> <td><input type="checkbox"/></td> <td>dnpDPcfg.xml</td> <td>Device Profile config. values</td> </tr> <tr> <td><input type="checkbox"/></td> <td><input type="checkbox"/></td> <td>_____*.xml</td> <td></td> </tr> </tbody> </table> <p>_____</p> <ul style="list-style-type: none"> * The Complete Device Profile Document contains the capabilities, Current Value, and configurable methods columns. * The Device Profile Capabilities contains only the capabilities and configurable methods columns. * The Device Profile Config. Values contains only the Current Value column. 	Rd	Wr	Filename	Description of Contents	<input type="checkbox"/>	<input type="checkbox"/>	dnpDP.xml	Complete Device Profile	<input type="checkbox"/>	<input type="checkbox"/>	dnpDPcap.xml	Device Profile Capabilities	<input type="checkbox"/>	<input type="checkbox"/>	dnpDPcfg.xml	Device Profile config. values	<input type="checkbox"/>	<input type="checkbox"/>	_____*.xml		Not supported	
Rd	Wr	Filename	Description of Contents																				
<input type="checkbox"/>	<input type="checkbox"/>	dnpDP.xml	Complete Device Profile																				
<input type="checkbox"/>	<input type="checkbox"/>	dnpDPcap.xml	Device Profile Capabilities																				
<input type="checkbox"/>	<input type="checkbox"/>	dnpDPcfg.xml	Device Profile config. values																				
<input type="checkbox"/>	<input type="checkbox"/>	_____*.xml																					
1.1.13 Connections Supported:	<input checked="" type="checkbox"/> Serial (complete section 1.2) <input checked="" type="checkbox"/> IP Networking (complete section 1.3) <input type="checkbox"/> Other, explain <p>_____</p>																						

1.2 SERIAL CONNECTIONS	Capabilities	Current Value	If configurable, list methods
1.2.1 Port Name	CON 2		
1.2.2 Serial Connection Parameters:	<input type="checkbox"/> Asynchronous - 8 Data Bits, 1 Start Bit, 1 Stop Bit, No Parity <input checked="" type="checkbox"/> Other, explain – <u>Asynchronous with selectable parity</u>	Parity - –one	F-PRO 2000 Offliner
1.2.3 Baud Rate:	<input type="checkbox"/> Fixed at _____ <input type="checkbox"/> Configurable, range _____ to _____ <input checked="" type="checkbox"/> Configurable, selectable from 2400, 4800, 9600, 19200, 38400 and 57600 <input type="checkbox"/> Configurable, other, describe _____	9600	F-PRO 2000 Offliner

<p>1.2.4 Hardware Flow Control (Handshaking): <i>Describe hardware signaling requirements of the interface. Where a transmitter or receiver is inhibited until a given control signal is asserted, it is considered to require that signal prior to sending or receiving characters. Where a signal is asserted prior to transmitting, that signal will be maintained active until after the end of transmission. Where a signal is asserted to enable reception, any data sent to the device when the signal is not active could be discarded.</i></p>	<p><input type="checkbox"/> None</p> <p>RS-232 / V.24 / V.28 Options: Before Tx, Asserts: <input type="checkbox"/> RTS <input type="checkbox"/> DTR Before Rx, Asserts: <input type="checkbox"/> RTS <input type="checkbox"/> DTR Always Asserts: <input type="checkbox"/> RTS <input type="checkbox"/> DTR</p> <p>Before Tx, Requires: Asserted Deasserted <input type="checkbox"/> <input type="checkbox"/> CTS <input type="checkbox"/> <input type="checkbox"/> DCD <input type="checkbox"/> <input type="checkbox"/> DSR <input type="checkbox"/> <input type="checkbox"/> RI <input type="checkbox"/> Rx Inactive</p> <p>Before Rx, Requires: Asserted Deasserted <input type="checkbox"/> <input type="checkbox"/> CTS <input type="checkbox"/> <input type="checkbox"/> DCD <input type="checkbox"/> <input type="checkbox"/> DSR <input type="checkbox"/> <input type="checkbox"/> RI</p> <p>Always Ignores: <input type="checkbox"/> CTS <input type="checkbox"/> DCD <input type="checkbox"/> DSR <input type="checkbox"/> RI</p> <p><input type="checkbox"/> Other, explain _____</p> <p>RS-422 / V.11 Options: <input type="checkbox"/> Requires Indication before Rx <input type="checkbox"/> Asserts Control before Tx <input type="checkbox"/> Other, explain _____</p> <p>RS-485 Options: <input type="checkbox"/> Requires Rx inactive before Tx <input type="checkbox"/> Other, explain _____</p>	<p>Not supported</p>	
<p>1.2.5 Interval to Request Link Status:</p>	<p><input checked="" type="checkbox"/> Not Supported <input type="checkbox"/> Fixed at _____ seconds <input type="checkbox"/> Configurable, range _____ to _____ seconds <input type="checkbox"/> Configurable, selectable from _____, _____, _____ seconds <input type="checkbox"/> Configurable, other, describe _____</p>		
<p>1.2.6 Supports DNP3 Collision Avoidance:</p>	<p><input checked="" type="checkbox"/> No <input type="checkbox"/> Yes, explain _____</p>		

<p>1.2.7 Receiver Inter-character Timeout:</p>	<p><input checked="" type="checkbox"/> Not checked</p> <p><input type="checkbox"/> No gap permitted</p> <p><input type="checkbox"/> Fixed at _____ bit times</p> <p><input type="checkbox"/> Fixed at _____ ms</p> <p><input type="checkbox"/> Configurable, range _____ to _____ bit times</p> <p><input type="checkbox"/> Configurable, range _____ to _____ ms</p> <p><input type="checkbox"/> Configurable, Selectable from _____, _____, _____ bit times</p> <p><input type="checkbox"/> Configurable, Selectable from _____, _____, _____ ms</p> <p><input type="checkbox"/> Configurable, other, describe _____</p> <p><input type="checkbox"/> Variable, explain _____</p>		
<p>1.2.8 Inter-character gaps in transmission:</p>	<p><input checked="" type="checkbox"/> None (always transmits with no inter-character gap)</p> <p><input type="checkbox"/> Maximum _____ bit times</p> <p><input type="checkbox"/> Maximum _____ ms</p>		

1.3 IP NETWORKING	Capabilities	Current Value	If configurable, list methods
1.3.1 Port Name	CON 1 Network		
1.3.2 Type of End Point:	<input type="checkbox"/> TCP Initiating (Master Only) <input checked="" type="checkbox"/> TCP Listening (Outstation Only) <input type="checkbox"/> TCP Dual (required for Masters) <input checked="" type="checkbox"/> UDP Datagram (required)	Not configured for DNP	F-PRO 2000 Offliner
1.3.3 IP Address of this Device:		192.168.100.80	F-PRO 2000 Offliner
1.3.4 Subnet Mask:		255.255.255.0	F-PRO 2000 Offliner
1.3.5 Gateway IP Address:		192.168.100.1	F-PRO 2000 Offliner
1.3.6 Accepts TCP Connections or UDP Datagrams from:	<input checked="" type="checkbox"/> Allows all (show as *.*.* in 1.3.7) <input checked="" type="checkbox"/> Limits based on an IP address <input checked="" type="checkbox"/> Limits based on list of IP addresses <input type="checkbox"/> Limits based on a wildcard IP address <input type="checkbox"/> Limits based on list of wildcard IP addresses <input type="checkbox"/> Other validation, explain _____	Limits based on an IP address	F-PRO 2000 Offliner
1.3.7 IP Address(es) from which TCP Connections or UDP Datagrams are accepted:		192.168.100.65	F-PRO 2000 Offliner
1.3.8 TCP Listen Port Number:	<input type="checkbox"/> Not Applicable (Master w/o dual end point) <input type="checkbox"/> Fixed at 20,000 <input checked="" type="checkbox"/> Configurable, range <u>1025</u> to <u>32737</u> <input type="checkbox"/> Configurable, selectable from _____ <input type="checkbox"/> Configurable, other, describe _____	20,000	F-PRO 2000 Offliner

1.3.9 TCP Listen Port Number of remote device:	<input checked="" type="checkbox"/> Not Applicable (Outstation w/o dual end point) <input type="checkbox"/> Fixed at 20,000 <input type="checkbox"/> Configurable, range _____ to _____ <input type="checkbox"/> Configurable, selectable from _____, _____, _____ <input type="checkbox"/> Configurable, other, describe _____	NA	
1.3.10 TCP Keep-alive timer:	<input type="checkbox"/> Fixed at _____ms <input checked="" type="checkbox"/> Configurable, range <u>5</u> to <u>3,600</u> s and 0 to disable <input type="checkbox"/> Configurable, selectable from _____, _____, _____ms <input type="checkbox"/> Configurable, other, describe _____	Disabled	F-PRO 2000 Offliner
1.3.11 Local UDP port:	<input type="checkbox"/> Fixed at 20,000 <input checked="" type="checkbox"/> Configurable, range <u>1025</u> to <u>32737</u> <input type="checkbox"/> Configurable, selectable from _____, _____, _____ <input type="checkbox"/> Configurable, other, describe _____ <input type="checkbox"/> Let system choose (Master only)	20,000	F-PRO 2000 Offliner
1.3.12 Destination UDP port for DNP3 Requests (Master Only):		NA	
1.3.13 Destination UDP port for initial unsolicited null responses (UDP only Outstations):	<input checked="" type="checkbox"/> None <input type="checkbox"/> Fixed at 20,000 <input type="checkbox"/> Configurable, range _____ to _____ <input type="checkbox"/> Configurable, selectable from _____, _____, _____ <input type="checkbox"/> Configurable, other, describe _____	NA	
1.3.14 Destination UDP port for responses:	<input type="checkbox"/> None <input type="checkbox"/> Fixed at 20,000 <input checked="" type="checkbox"/> Configurable, range <u>1025</u> to <u>32737</u> <input type="checkbox"/> Configurable, selectable from _____, _____, _____ <input type="checkbox"/> Configurable, other, describe _____ <input type="checkbox"/> Use source port number	20,000	F-PRO 2000 Offliner

1.3.15 Multiple master connections (Outstations Only):	<input checked="" type="checkbox"/> Supports multiple masters (Outstations only) If supported, the following methods may be used: <input checked="" type="checkbox"/> Method 1 (based on IP address) - required <input checked="" type="checkbox"/> Method 2 (based on IP port number) - recommended <input checked="" type="checkbox"/> Method 3 (browsing for static data) - optional	Method 1 (based on IP address)	F-PRO 2000 Offliner
1.3.16 Time synchronization support:	<input type="checkbox"/> DNP3 LAN procedure (function code 24) <input type="checkbox"/> DNP3 Write Time (not recommended over LAN) <input type="checkbox"/> Other, explain _____ <input checked="" type="checkbox"/> Not Supported		

1.4 LINK LAYER	Capabilities	Current Value	If configurable, list methods
1.4.1 Data Link Address:	<input type="checkbox"/> Fixed at _____ <input checked="" type="checkbox"/> Configurable, range <u>1</u> to <u>65519</u> <input type="checkbox"/> Configurable, selectable from _____, _____, _____ <input type="checkbox"/> Configurable, other, describe _____	1	F-PRO 2000 Offliner
1.4.2 DNP3 Source Address Validation:	<input checked="" type="checkbox"/> Never <input type="checkbox"/> Always, one address allowed (shown in 1.4.3) <input type="checkbox"/> Always, any one of multiple addresses allowed (each selectable as shown in 1.4.3) <input type="checkbox"/> Sometimes, explain _____		
1.4.3 DNP3 Source Address(es) expected when Validation is Enabled:	<input type="checkbox"/> Configurable to any 16 bit DNP Data Link Address value <input type="checkbox"/> Configurable, range _____ to _____ <input type="checkbox"/> Configurable, selectable from _____, _____, _____ <input type="checkbox"/> Configurable, other, describe _____	NA	
1.4.4 Self Address Support using address 0xFFFC:	<input type="checkbox"/> Yes (only allowed if configurable) <input checked="" type="checkbox"/> No	NA	
1.4.5 Sends Confirmed User Data Frames:	<input type="checkbox"/> Always <input type="checkbox"/> Sometimes, explain _____ <input type="checkbox"/> Never <input checked="" type="checkbox"/> Configurable, either always or never		F-PRO 2000 Offliner (to disable, set Data Link Timeout to 0)
1.4.6 Data Link Layer Confirmation Timeout:	<input type="checkbox"/> None <input type="checkbox"/> Fixed at <u> </u> ms <input checked="" type="checkbox"/> Configurable, range <u>0</u> to <u>2,000</u> ms <input type="checkbox"/> Configurable, selectable from _____, _____, _____ms <input type="checkbox"/> Configurable, other, describe _____ <input type="checkbox"/> Variable, explain _____	500 ms	F-PRO 2000 Offliner

1.4.7 Maximum Data Link Retries:	<input type="checkbox"/> Never Retries <input checked="" type="checkbox"/> Fixed at <u>3</u> <input type="checkbox"/> Configurable, range _____ to _____ <input type="checkbox"/> Configurable, selectable from _____, _____, _____ <input type="checkbox"/> Configurable, other, describe _____	3	
1.4.8 Maximum number of octets Transmitted in a Data Link Frame:	<input checked="" type="checkbox"/> Fixed at <u>292</u> <input type="checkbox"/> Configurable, range _____ to _____ <input type="checkbox"/> Configurable, selectable from _____, _____, _____ <input type="checkbox"/> Configurable, other, describe _____	292	
1.4.9 Maximum number of octets that can be Received in a Data Link Frame:	<input checked="" type="checkbox"/> Fixed at <u>292</u> <input type="checkbox"/> Configurable, range _____ to _____ <input type="checkbox"/> Configurable, selectable from _____, _____, _____ <input type="checkbox"/> Configurable, other, describe _____	292	

1.5 APPLICATION LAYER	Capabilities	Current Value	If configurable, list methods
1.5.1 Maximum number of octets Transmitted in an Application Layer Fragment other than File Transfer:	<input checked="" type="checkbox"/> Fixed at <u>2048</u> <input type="checkbox"/> Configurable, range _____ to _____ <input type="checkbox"/> Configurable, selectable from _____, _____, _____ <input type="checkbox"/> Configurable, other, describe _____	2048	
1.5.2 Maximum number of octets Transmitted in an Application Layer Fragment containing File Transfer:	<input type="checkbox"/> Fixed at _____ <input type="checkbox"/> Configurable, range _____ to _____ <input type="checkbox"/> Configurable, selectable from _____, _____, _____ <input type="checkbox"/> Configurable, other, describe _____	NA	
1.5.3 Maximum number of octets that can be Received in an Application Layer Fragment:	<input checked="" type="checkbox"/> Fixed at <u>2048</u> <input type="checkbox"/> Configurable, range _____ to _____ <input type="checkbox"/> Configurable, selectable from _____, _____, _____ <input type="checkbox"/> Configurable, other, describe _____	2048	
1.5.4 Timeout waiting for Complete Application Layer Fragment:	<input type="checkbox"/> None <input checked="" type="checkbox"/> Fixed at <u>2,000</u> ms <input type="checkbox"/> Configurable, range _____ to _____ ms <input type="checkbox"/> Configurable, selectable from _____, _____, _____ ms <input type="checkbox"/> Configurable, other, describe _____ <input type="checkbox"/> Variable, explain _____	2,000 ms	
1.5.5 Maximum number of objects allowed in a single control request for CROB (group 12):	<input checked="" type="checkbox"/> Fixed at <u>16</u> <input type="checkbox"/> Configurable, range _____ to _____ <input type="checkbox"/> Configurable, selectable from _____, _____, _____ <input type="checkbox"/> Configurable, other, describe _____ <input type="checkbox"/> Variable, explain _____	16	

<p>1.5.6 Maximum number of objects allowed in a single control request for Analog Outputs (group 41):</p>	<input type="checkbox"/> Fixed at _ <input type="checkbox"/> Configurable, range _____ to _____ <input type="checkbox"/> Configurable, selectable from _____, _____, _____ <input type="checkbox"/> Configurable, other, describe _____ <input type="checkbox"/> Variable, explain _____ _____	Analog Outputs not supported	
<p>1.5.7 Maximum number of objects allowed in a single control request for Data Sets (groups 85,86,87):</p>	<input type="checkbox"/> Fixed at __ <input type="checkbox"/> Configurable, range _____ to _____ <input type="checkbox"/> Configurable, selectable from _____, _____, _____ <input type="checkbox"/> Configurable, other, describe _____ <input type="checkbox"/> Variable, explain _____ _____	Data Sets not supported	
<p>1.5.8 Supports mixing object groups (AOBs, CROBs and Data Sets) in the same control request:</p>	<input type="checkbox"/> Not applicable – controls are not supported <input type="checkbox"/> Yes <input checked="" type="checkbox"/> No	Analog Outputs not supported	

1.6 FILL OUT THE FOLLOWING ITEMS FOR OUTSTATIONS	Capabilities	Current Value	If configurable, list methods
1.6.1 Timeout waiting for Application Confirm of solicited response message:	<input type="checkbox"/> None <input checked="" type="checkbox"/> Fixed at 5,000 ms <input type="checkbox"/> Configurable, range _____ to _____ ms <input type="checkbox"/> Configurable, selectable from _____, _____, _____ ms <input type="checkbox"/> Configurable, other, describe _____ <input type="checkbox"/> Variable, explain _____	5,000 ms	
1.6.2 How often is time synchronization required from the master?	<input checked="" type="checkbox"/> Never needs time <input type="checkbox"/> Within _____ seconds after IIN1.4 is set <input type="checkbox"/> Periodically every _____ seconds		
1.6.3 Device Trouble Bit IIN1.6:	<input type="checkbox"/> Never used <input checked="" type="checkbox"/> Reason for setting: <u>Unable to access requested data or execute CROB, assuming a valid request has been received</u>		
1.6.4 File Handle Timeout:	<input checked="" type="checkbox"/> Not applicable, files not supported <input type="checkbox"/> Fixed at _____ ms <input type="checkbox"/> Configurable, range _____ to _____ ms <input type="checkbox"/> Configurable, selectable from _____, _____, _____ ms <input type="checkbox"/> Configurable, other, describe _____ <input type="checkbox"/> Variable, explain _____		
1.6.5 Event Buffer Overflow Behavior:	<input type="checkbox"/> Discard the oldest event <input checked="" type="checkbox"/> Discard the newest event <input type="checkbox"/> Other, explain _____		
1.6.6 Event Buffer Organization:	i. Single buffer for the Object Groups 2 and 32, size 200.		
1.6.7 Sends Multi-Fragment Responses:	<input checked="" type="checkbox"/> Yes <input type="checkbox"/> No		
1.6.8 DNP Command Settings preserved through a device reset:	<input type="checkbox"/> Assign Class <input type="checkbox"/> Analog Deadbands <input type="checkbox"/> Data Set Prototypes <input type="checkbox"/> Data Set Descriptors	Not supported	

1.7 OUTSTATION UNSOLICITED RESPONSE SUPPORT	Capabilities	Current Value	If configurable, list methods
1.7.1 Supports Unsolicited Reporting:	<input checked="" type="checkbox"/> Not Supported <input type="checkbox"/> Configurable, selectable from On and Off	NA	

1.8 OUTSTATION PERFORMANCE	Capabilities	Current Value	If configurable, list methods
1.8.1 Maximum Time Base Drift (milliseconds per minute):		NA, not synchronized by DNP	
1.8.2 When does outstation set IIN1.4?	<input checked="" type="checkbox"/> Never <input type="checkbox"/> Asserted at startup until first Time Synchronization request received <input type="checkbox"/> Periodically, range ____ to ____ seconds <input type="checkbox"/> Periodically, selectable from ____, ____, ____ seconds <input type="checkbox"/> Range ____ to ____ seconds after last time sync <input type="checkbox"/> Selectable from ____, ____, ____ seconds after last time sync <input type="checkbox"/> When time error may have drifted by range ____ to ____ ms <input type="checkbox"/> When time error may have drifted by selectable from ____, ____, ____	NA	
1.8.3 Maximum Internal Time Reference Error when set via DNP (ms):		NA	
1.8.4 Maximum Delay Measurement error (ms):		NA	
1.8.5 Maximum Response time (ms):		300 ms – TCP mode (for the case all supported points mapped to the DNP point lists)	F-PRO 2000 Offliner
1.8.6 Maximum time from start-up to IIN 1.4 assertion (ms):		NA	

1.8.7 Maximum Event Time-tag error for local Binary and Double-bit I/O (ms):		<ul style="list-style-type: none"> – 0.5208 ms for 60Hz systems – 0.6250 ms for 50 Hz systems 	
1.8.8 Maximum Event Time-tag error for local I/O other than Binary and Double-bit data types (ms):		<ul style="list-style-type: none"> – 0.5208 ms for 60Hz systems – 0.6250 ms for 50 Hz systems 	

CAPABILITIES AND CURRENT SETTINGS FOR DEVICE DATABASE

The following tables identify the capabilities and current settings for each DNP3 data type. Each data type also provides a table defining the data points available in the device, default point lists configuration and a description of how this information can be obtained in case of customized point configuration.

1.9 SINGLE-BIT BINARY INPUTS Static (Steady-State) Group Number: 1 Event Group Number: 2	Capabilities	Current Value	If configurable, list methods
1.9.1 Static Variation reported when variation 0 requested:	<input checked="" type="checkbox"/> Variation 1 – Single-bit Packed format <input type="checkbox"/> Variation 2 – Single-bit with flag <input type="checkbox"/> Based on point Index (add column to table below)		
1.9.2 Event Variation reported when variation 0 requested:	<input type="checkbox"/> Variation 1 – without time <input checked="" type="checkbox"/> Variation 2 – with absolute time <input type="checkbox"/> Variation 3 – with relative time <input type="checkbox"/> Based on point Index (add column to table below)		
1.9.3 Event reporting mode:	<input type="checkbox"/> Only most recent <input checked="" type="checkbox"/> All events		
1.9.4 Binary Inputs included in Class 0 response:	<input checked="" type="checkbox"/> Always <input type="checkbox"/> Never <input type="checkbox"/> Only if point is assigned to Class 1, 2, or 3 <input type="checkbox"/> Based on point Index (add column to table below)		F-PRO 2000 Offliner
1.9.5 Definition of Binary Input Point List:	<input type="checkbox"/> Fixed, list shown in table below <input checked="" type="checkbox"/> Configurable <input type="checkbox"/> Other, explain _____ _____	Complete list is shown in the table below; points excluded from the default configuration are marked with ‘*’	F-PRO 2000 Offliner

NOTES	<ol style="list-style-type: none"> Binary Inputs are scanned with 1 ms resolution. Binary Input data points are user selectable; the data points available in the device for any given Binary Input point selection can be obtained through the F-PRO 2000 Offliner software (see SCADA Setting Summary).
--------------	---

Point Index	Name	Default Class Assigned to Events (1, 2, 3 or none)	Name for State when value is 0	Name for State when value is 1	Description
0	External Input 1	1	Inactive	Active	
1	External Input 2	1	Inactive	Active	
2	External Input 3	1	Inactive	Active	
3	External Input 4	1	Inactive	Active	
4	Virtual Input 1	1	Inactive	Active	
5	Virtual Input 2	1	Inactive	Active	
6	Virtual Input 3	1	Inactive	Active	
7	Virtual Input 4	1	Inactive	Active	
8	Virtual Input 5	1	Inactive	Active	
9	Virtual Input 6	1	Inactive	Active	
10	Virtual Input 7	1	Inactive	Active	
11	Virtual Input 8	1	Inactive	Active	
12	Virtual Input 9	1	Inactive	Active	
13	Virtual Input 10	1	Inactive	Active	
14	Virtual Input 11	1	Inactive	Active	
15	Virtual Input 12	1	Inactive	Active	
16	Virtual Input 13	1	Inactive	Active	
17	Virtual Input 14	1	Inactive	Active	
18	Virtual Input 15	1	Inactive	Active	
19	Virtual Input 16	1	Inactive	Active	

20	Virtual Input 17	1	Inactive	Active	
21	Virtual Input 18	1	Inactive	Active	
22	Virtual Input 19	1	Inactive	Active	
23	Virtual Input 20	1	Inactive	Active	
24	Virtual Input 21	1	Inactive	Active	
25	Virtual Input 22	1	Inactive	Active	
26	Virtual Input 23	1	Inactive	Active	
27	Virtual Input 24	1	Inactive	Active	
28	Virtual Input 25	1	Inactive	Active	
29	Virtual Input 26	1	Inactive	Active	
30	Virtual Input 27	1	Inactive	Active	
31	Virtual Input 28	1	Inactive	Active	
32	Virtual Input 29	1	Inactive	Active	
33	Virtual Input 30	1	Inactive	Active	
34	ProLogic 1	1	Inactive	Active	
35	ProLogic 2	1	Inactive	Active	
36	ProLogic 3	1	Inactive	Active	
37	ProLogic 4	1	Inactive	Active	
38	ProLogic 5	1	Inactive	Active	
39	ProLogic 6	1	Inactive	Active	
40	ProLogic 7	1	Inactive	Active	
41	ProLogic 8	1	Inactive	Active	

42	ProLogic 9	1	Inactive	Active	
43	ProLogic 10	1	Inactive	Active	
44	ProLogic 11	1	Inactive	Active	
45	ProLogic 12	1	Inactive	Active	
46	ProLogic 13	1	Inactive	Active	
47	ProLogic 14	1	Inactive	Active	
48	ProLogic 15	1	Inactive	Active	
49	ProLogic 16	1	Inactive	Active	
50	ProLogic 17	1	Inactive	Active	
51	ProLogic 18	1	Inactive	Active	
52	ProLogic 19	1	Inactive	Active	
53	ProLogic 20	1	Inactive	Active	
54	27DT-1 Operated	1	Inactive	Active	
55	27DT-1 Operated A	1	Inactive	Active	
56	27DT-1 Operated B	1	Inactive	Active	
57	27DT-1 Operated C	1	Inactive	Active	
58	27DT-2 Operated	1	Inactive	Active	
59	27DT-2 Operated A	1	Inactive	Active	
60	27DT-2 Operated B	1	Inactive	Active	
61	27DT-2 Operated C	1	Inactive	Active	
62	27DT-3 Operated	1	Inactive	Active	
63	27DT-3 Operated A	1	Inactive	Active	

64	27DT-3 Operated B	1	Inactive	Active	
65	27DT-3 Operated C	1	Inactive	Active	
66	27DT-4 Operated	1	Inactive	Active	
67	27DT-4 Operated A	1	Inactive	Active	
68	27DT-4 Operated B	1	Inactive	Active	
69	27DT-4 Operated C	1	Inactive	Active	
70	27DT-5 Operated	1	Inactive	Active	
71	27DT-5 Operated A	1	Inactive	Active	
72	27DT-5 Operated B	1	Inactive	Active	
73	27DT-5 Operated C	1	Inactive	Active	
74	27DT-6 Operated	1	Inactive	Active	
75	27DT-6 Operated A	1	Inactive	Active	
76	27DT-6 Operated B	1	Inactive	Active	
77	27DT-6 Operated C	1	Inactive	Active	
78	27IT-1 Operated	1	Inactive	Active	
79	27IT-1 Operated A	1	Inactive	Active	
80	27IT-1 Operated B	1	Inactive	Active	
81	27IT-1 Operated C	1	Inactive	Active	
82	27IT-2 Operated	1	Inactive	Active	
83	27IT-2 Operated A	1	Inactive	Active	
84	27IT-2 Operated B	1	Inactive	Active	
85	27IT-2 Operated C	1	Inactive	Active	

86	59DT-1 Operated	1	Inactive	Active	
87	59DT-1 Operated A	1	Inactive	Active	
88	59DT-1 Operated B	1	Inactive	Active	
89	59DT-1 Operated C	1	Inactive	Active	
90	59DT-2 Operated	1	Inactive	Active	
91	59DT-2 Operated A	1	Inactive	Active	
92	59DT-2 Operated B	1	Inactive	Active	
93	59DT-2 Operated C	1	Inactive	Active	
94	59DT-3 Operated	1	Inactive	Active	
95	59DT-3 Operated A	1	Inactive	Active	
96	59DT-3 Operated B	1	Inactive	Active	
97	59DT-3 Operated C	1	Inactive	Active	
98	59DT-4 Operated	1	Inactive	Active	
99	59DT-4 Operated A	1	Inactive	Active	
100	59DT-4 Operated B	1	Inactive	Active	
101	59DT-4 Operated C	1	Inactive	Active	
102	59DT-5 Operated	1	Inactive	Active	
103	59DT-5 Operated A	1	Inactive	Active	
104	59DT-5 Operated B	1	Inactive	Active	
105	59DT-5 Operated C	1	Inactive	Active	
106	59DT-6 Operated	1	Inactive	Active	
107	59DT-6 Operated A	1	Inactive	Active	

108	59DT-6 Operated B	1	Inactive	Active	
109	59DT-6 Operated C	1	Inactive	Active	
110	59IT-1 Operated	1	Inactive	Active	
111	59IT-1 Operated A	1	Inactive	Active	
112	59IT-1 Operated B	1	Inactive	Active	
113	59IT-1 Operated C	1	Inactive	Active	
114	59IT-2 Operated	1	Inactive	Active	
115	59IT-2 Operated A	1	Inactive	Active	
116	59IT-2 Operated B	1	Inactive	Active	
117	59IT-2 Operated C	1	Inactive	Active	
118	50/67-1 Operated	1	Inactive	Active	
119	50/67-1 Operated A	1	Inactive	Active	
120	50/67-1 Operated B	1	Inactive	Active	
121	50/67-1 Operated C	1	Inactive	Active	
122	50/67-2 Operated	1	Inactive	Active	
123	50/67-2 Operated A	1	Inactive	Active	
124	50/67-2 Operated B	1	Inactive	Active	
125	50/67-2 Operated C	1	Inactive	Active	
126	51/67-1 Operated	1	Inactive	Active	
127	51/67-1 Operated A	1	Inactive	Active	
128	51/67-1 Operated B	1	Inactive	Active	
129	51/67-1 Operated C	1	Inactive	Active	

130	51/67-2 Operated	1	Inactive	Active	
131	51/67-2 Operated A	1	Inactive	Active	
132	51/67-2 Operated B	1	Inactive	Active	
133	51/67-2 Operated C	1	Inactive	Active	
134	50N/67N-1 Operated	1	Inactive	Active	
135	50N/67N-2 Operated	1	Inactive	Active	
136	51N/67N-1 Operated	1	Inactive	Active	
137	51N/67N-2 Operated	1	Inactive	Active	
138	46/50 Operated	1	Inactive	Active	
139	46/51 Operated	1	Inactive	Active	
140	49 Operated	1	Inactive	Active	
141	49 Alarm Operated	1	Inactive	Active	
142	50BF-D1 Operated	1	Inactive	Active	
143	50BF-D2 Operated	1	Inactive	Active	
144	46BC Operated	1	Inactive	Active	
145	81HBL2 Operated	1	Inactive	Active	
146	74TCS-1 Operated	1	Inactive	Active	
147	74TCS-2 Operated	1	Inactive	Active	
148	79 Initiate	1	Inactive	Active	
149	79 Reclose	1	Inactive	Active	
150	79 Lockout	1	Inactive	Active	
151	79 Block	1	Inactive	Active	

152	I2T Limit Operated	1	Inactive	Active	
153	60VTS Operated	1	Inactive	Active	
154	60CTS Operated	1	Inactive	Active	
155	Output Contact 1	1	Open	Closed	
156	Output Contact 2	1	Open	Closed	
157	Output Contact 3	1	Open	Closed	
158	Output Contact 4	1	Open	Closed	
159	Output Contact 5	1	Open	Closed	
160	Output Contact 6	1	Open	Closed	
161	Output Contact 7	1	Open	Closed	
162	Output Contact 8	1	Open	Closed	

1.10 BINARY OUTPUT STATUS AND CONTROL RELAY OUTPUT BLOCK Binary Output Status Group Number: 10 CROB Group Number: 12	Capabilities	Current Value	If configurable, list methods
1.10.1 Minimum pulse time allowed with Trip, Close, and Pulse On commands:	<input checked="" type="checkbox"/> Fixed at <u>0,000</u> ms (hardware may limit this further) <input type="checkbox"/> Based on point Index (add column to table below)		
1.10.2 Maximum pulse time allowed with Trip, Close, and Pulse On commands:	<input checked="" type="checkbox"/> Fixed at <u>0,000</u> ms (hardware may limit this further) <input type="checkbox"/> Based on point Index (add column to table below)		
1.10.3 Binary Output Status included in Class 0 response:	<input checked="" type="checkbox"/> Always <input type="checkbox"/> Never <input type="checkbox"/> Only if point is assigned to Class 1, 2, or 3 <input type="checkbox"/> Based on point Index (add column to table below)		
1.10.4 Reports Output Command Event Objects:	<input checked="" type="checkbox"/> Never <input type="checkbox"/> Only upon a successful Control <input type="checkbox"/> Upon all control attempts	Not supported	
1.10.5 Event Variation reported when variation 0 requested:	<input type="checkbox"/> Variation 1 – without time <input type="checkbox"/> Variation 2 – with absolute time <input type="checkbox"/> Based on point Index (add column to table below)	Not supported	F-PRO 2000 Offliner (See Note 2 below)
1.10.6 Command Event Variation reported when variation 0 requested:	<input type="checkbox"/> Variation 1 – without time <input type="checkbox"/> Variation 2 – with absolute time <input type="checkbox"/> Based on point Index (add column to table below)	Not supported	F-PRO 2000 Offliner (See Note 2 below)
1.10.7 Event reporting mode:	<input type="checkbox"/> Only most recent <input type="checkbox"/> All events	Not supported	F-PRO 2000 Offliner (See Note 2 below)

1.10.8 Command Event reporting mode:	<input type="checkbox"/> Only most recent <input type="checkbox"/> All events	Not supported	
1.10.9 Maximum Time between Select and Operate:	<input type="checkbox"/> Not Applicable <input checked="" type="checkbox"/> Fixed at 10 seconds <input type="checkbox"/> Configurable, range _____ to _____ seconds <input type="checkbox"/> Configurable, selectable from _____, _____, _____ seconds <input type="checkbox"/> Configurable, other, describe _____ <input type="checkbox"/> Variable, explain _____ <input type="checkbox"/> Based on point Index (add column to table below)	10 s	
1.10.10 Definition of Binary Output Status/Control relay output block (CROB) Point List:	<input type="checkbox"/> Fixed, list shown in table below <input checked="" type="checkbox"/> Configurable <input type="checkbox"/> Other, explain _____ _____	Complete list is shown in the table below; points excluded from the default configuration are marked with '**'	F-PRO 2000 Offliner

NOTES	<ol style="list-style-type: none"> 1. Binary Outputs are scanned with 500 ms resolution. 2. Events are not supported for Binary Outputs (group 10), but most of Binary Output points can be mapped to Binary Inputs (group 2) with full Event and Class Data support. See F-PRO 2000 Offliner/DNP Configuration/Point Map screen for complete point lists and configuration options. 3. Virtual Inputs (default Binary Output points 14-43) can be used to control relay output contacts. See F-PRO 2000 Offliner/Setting Group X/Output Matrix screen for configuration options. 4. Binary Output data points are user selectable; the data points available in the device for any given Binary Output point selection can be obtained through the F-PRO 2000 Offliner software (see SCADA Setting Summary).
--------------	---

Point Index	Name	Supported Control Operations											Name for State when value is 0	Name for State when value is 1	Default Class Assigned to Events (1, 2, 3 or none)		Description
		Select/Operate	Direct Operate	Direct Operate – No Ack	Pulse On / NUL	Pulse Off	Latch On / NUL	Latch Off / NUL	Trip	Close	Count > 1	Cancel Currently Running Operation			Change	Command	
0	Output Contact 1	-	-	-	-	-	-	-	-	-	-	-	Open	Closed	None	None	
1	Output Contact 2	-	-	-	-	-	-	-	-	-	-	-	Open	Closed	None	None	
2	Output Contact 3	-	-	-	-	-	-	-	-	-	-	-	Open	Closed	None	None	
3	Output Contact 4	-	-	-	-	-	-	-	-	-	-	-	Open	Closed	None	None	
4	Output Contact 5	-	-	-	-	-	-	-	-	-	-	-	Open	Closed	None	None	
5	Output Contact 6	-	-	-	-	-	-	-	-	-	-	-	Open	Closed	None	None	
6	Output Contact 7	-	-	-	-	-	-	-	-	-	-	-	Open	Closed	None	None	
7	Output Contact 8	-	-	-	-	-	-	-	-	-	-	-	Open	Closed	None	None	
8	Virtual Input 1	Y	Y	Y	Y	-	Y	Y	-	-	-	-	Inactive	Active	None	None	Pulse duration fixed at 1 s
9	Virtual Input 2	Y	Y	Y	Y	-	Y	Y	-	-	-	-	Inactive	Active	None	None	Pulse duration fixed at 1 s
10	Virtual Input 3	Y	Y	Y	Y	-	Y	Y	-	-	-	-	Inactive	Active	None	None	Pulse duration fixed at 1 s
11	Virtual Input 4	Y	Y	Y	Y	-	Y	Y	-	-	-	-	Inactive	Active	None	None	Pulse duration fixed at 1 s
12	Virtual Input 5	Y	Y	Y	Y	-	Y	Y	-	-	-	-	Inactive	Active	None	None	Pulse duration fixed at 1 s
13	Virtual Input 6	Y	Y	Y	Y	-	Y	Y	-	-	-	-	Inactive	Active	None	None	Pulse duration fixed at 1 s
14	Virtual Input 7	Y	Y	Y	Y	-	Y	Y	-	-	-	-	Inactive	Active	None	None	Pulse duration fixed at 1 s
15	Virtual Input 8	Y	Y	Y	Y	-	Y	Y	-	-	-	-	Inactive	Active	None	None	Pulse duration fixed at 1 s
16	Virtual Input 9	Y	Y	Y	Y	-	Y	Y	-	-	-	-	Inactive	Active	None	None	Pulse duration fixed at 1 s
17	Virtual Input 10	Y	Y	Y	Y	-	Y	Y	-	-	-	-	Inactive	Active	None	None	Pulse duration fixed at 1 s
18	Virtual Input 11	Y	Y	Y	Y	-	Y	Y	-	-	-	-	Inactive	Active	None	None	Pulse duration fixed at 1 s
19	Virtual Input 12	Y	Y	Y	Y	-	Y	Y	-	-	-	-	Inactive	Active	None	None	Pulse duration fixed at 1 s

20	Virtual Input 13	Y	Y	Y	Y	-	Y	Y	-	-	-	-	Inactive	Active	None	None	Pulse duration fixed at 1 s
21	Virtual Input 14	Y	Y	Y	Y	-	Y	Y	-	-	-	-	Inactive	Active	None	None	Pulse duration fixed at 1 s
22	Virtual Input 15	Y	Y	Y	Y	-	Y	Y	-	-	-	-	Inactive	Active	None	None	Pulse duration fixed at 1 s
23	Virtual Input 16	Y	Y	Y	Y	-	Y	Y	-	-	-	-	Inactive	Active	None	None	Pulse duration fixed at 1 s
24	Virtual Input 17	Y	Y	Y	Y	-	Y	Y	-	-	-	-	Inactive	Active	None	None	Pulse duration fixed at 1 s
25	Virtual Input 18	Y	Y	Y	Y	-	Y	Y	-	-	-	-	Inactive	Active	None	None	Pulse duration fixed at 1 s
26	Virtual Input 19	Y	Y	Y	Y	-	Y	Y	-	-	-	-	Inactive	Active	None	None	Pulse duration fixed at 1 s
27	Virtual Input 20	Y	Y	Y	Y	-	Y	Y	-	-	-	-	Inactive	Active	None	None	Pulse duration fixed at 1 s
28	Virtual Input 21	Y	Y	Y	Y	-	Y	Y	-	-	-	-	Inactive	Active	None	None	Pulse duration fixed at 1 s
29	Virtual Input 22	Y	Y	Y	Y	-	Y	Y	-	-	-	-	Inactive	Active	None	None	Pulse duration fixed at 1 s
30	Virtual Input 23	Y	Y	Y	Y	-	Y	Y	-	-	-	-	Inactive	Active	None	None	Pulse duration fixed at 1 s
31	Virtual Input 24	Y	Y	Y	Y	-	Y	Y	-	-	-	-	Inactive	Active	None	None	Pulse duration fixed at 1 s
32	Virtual Input 25	Y	Y	Y	Y	-	Y	Y	-	-	-	-	Inactive	Active	None	None	Pulse duration fixed at 1 s
33	Virtual Input 26	Y	Y	Y	Y	-	Y	Y	-	-	-	-	Inactive	Active	None	None	Pulse duration fixed at 1 s
34	Virtual Input 27	Y	Y	Y	Y	-	Y	Y	-	-	-	-	Inactive	Active	None	None	Pulse duration fixed at 1 s
35	Virtual Input 28	Y	Y	Y	Y	-	Y	Y	-	-	-	-	Inactive	Active	None	None	Pulse duration fixed at 1 s
36	Virtual Input 29	Y	Y	Y	Y	-	Y	Y	-	-	-	-	Inactive	Active	None	None	Pulse duration fixed at 1 s
37	Virtual Input 30	Y	Y	Y	Y	-	Y	Y	-	-	-	-	Inactive	Active	None	None	Pulse duration fixed at 1 s

1.11 ANALOG INPUT POINTS Static (Steady-State) Group Number: 30 Event Group Number: 32	Capabilities	Current Value	If configurable, list methods
1.11.1 Static Variation reported when variation 0 requested:	<input type="checkbox"/> Variation 1 – 32-bit with flag <input type="checkbox"/> Variation 2 – 16-bit with flag <input checked="" type="checkbox"/> Variation 3 – 32-bit without flag <input checked="" type="checkbox"/> Variation 4 – 16-bit without flag <input type="checkbox"/> Variation 5 – single-precision floating point with flag <input type="checkbox"/> Variation 6 – double-precision floating point with flag <input type="checkbox"/> Based on point Index (add column to table below)		
1.11.2 Event Variation reported when variation 0 requested:	<input checked="" type="checkbox"/> Variation 1 – 32-bit without time <input checked="" type="checkbox"/> Variation 2 – 16-bit without time <input type="checkbox"/> Variation 3 – 32-bit with time <input type="checkbox"/> Variation 4 – 16-bit with time <input type="checkbox"/> Variation 5 – single-precision floating point w/o time <input type="checkbox"/> Variation 6 – double-precision floating point w/o time <input type="checkbox"/> Variation 7 – single-precision floating point with time <input type="checkbox"/> Variation 8 – double-precision floating point with time <input type="checkbox"/> Based on point Index (add column to table below)		
1.11.3 Event reporting mode:	<input type="checkbox"/> Only most recent <input checked="" type="checkbox"/> All events		
1.11.4 Analog Inputs Included in Class 0 response:	<input checked="" type="checkbox"/> Always <input type="checkbox"/> Never <input type="checkbox"/> Only if point is assigned to Class 1, 2, or 3 <input type="checkbox"/> Based on point Index (add column to table below)		
1.11.5 How Deadbands are set:	<input type="checkbox"/> A. Global Fixed <input type="checkbox"/> B. Configurable through DNP <input checked="" type="checkbox"/> C. Configurable via other means <input type="checkbox"/> D. Other, explain <input type="checkbox"/> Based on point Index - column specifies which of the options applies, B, C, or D		F-PRO 2000 Offliner

1.11 ANALOG INPUT POINTS Static (Steady-State) Group Number: 30 Event Group Number: 32	Capabilities	Current Value	If configurable, list methods
1.11.6 Analog Deadband Algorithm: <i>simple - just compares the difference from the previous reported value</i>	<input checked="" type="checkbox"/> Simple <input type="checkbox"/> Integrating <input type="checkbox"/> Other, explain _____ _____		
1.11.7 Definition of Analog Input Point List:	<input type="checkbox"/> Fixed, list shown in table below <input checked="" type="checkbox"/> Configurable <input type="checkbox"/> Other, explain _____ _____	Default list is shown in table below	F-PRO 2000 Offliner

NOTES	<ol style="list-style-type: none"> 1. Analog Inputs are scanned with 500 ms resolution. 2. Nominal values in calculations for the following table are based on Secondary voltage * PT ratio for voltage channels, and either 1 A or 5A secondary current * CT ratio for current channels dependent upon the format of CT installed in the F-PRO. 3. Analog Input data points are user selectable; the data points available in the device for any given Analog Input point selection can be obtained through the F-PRO 2000 Offliner software (see SCADA Setting Summary).
--------------	---

Point Index	Name	Default Class Assigned to Events (1, 2, 3 or none)	Transmitted Value ¹		Scaling ²		Scale Units	Resolution ³ (default/ maximal)	Dead band (default / (range))	Dead band Units
			Minimum	Maximum	Multiplier (default / (range))	Offset				
0.	Va Magnitude	2	0	Configurable	0.01 / (0.00001- 1.0)	0.0	kV	0.01 / 0.00001	2.0 / (0.1 to 100.0)	% of nominal
1.	Va Angle	2	-18,000	18,000	0.1 / (0.01 – 1.0)	0.0	degrees	0.1 / 0.01	0.5 / (0.1 to 180.0)	degrees
2.	Vb Magnitude	2	0	Configurable	0.01 / (0.00001- 1.0)	0.0	kV	0.01 / 0.00001	2.0 / (0.1 to 100.0)	% of nominal
3.	Vb Angle	2	-18,000	18,000	0.1 / (0.01 – 1.0)	0.0	degrees	0.1 / 0.01	0.5 / (0.1 to 180.0)	degrees
4.	Vc Magnitude	2	0	Configurable	0.01 / (0.00001- 1.0)	0.0	kV	0.01 / 0.00001	2.0 / (0.1 to 100.0)	% of nominal
5.	Vc Angle	2	-18,000	18,000	0.1 / (0.01 – 1.0)	0.0	degrees	0.1 / 0.01	0.5 / (0.1 to 180.0)	degrees
6.	Vn Magnitude	2	0	Configurable	0.01 / (0.00001- 1.0)	0.0	kV	0.01 / 0.00001	2.0 / (0.1 to 100.0)	% of nominal
7.	Vn Angle	2	-18,000	18,000	0.1 / (0.01 – 1.0)	0.0	degrees	0.1 / 0.01	0.5 / (0.1 to 180.0)	degrees
8.	Ia Magnitude	2	0	Configurable	0.01 / (0.00001 – 10.0)	0.0	A	0.01 / 0.00001	2.0 / (0.1 to 100.0)	% of nominal
9.	Ia Angle	2	-18,000	18,000	0.1 / (0.01 – 1.0)	0.0	degrees	0.1 / 0.01	0.5 / (0.1 to 180.0)	degrees
10	Ib Magnitude	2	0	Configurable	0.01 / (0.00001 – 10.0)	0.0	A	0.01 / 0.00001	2.0 / (0.1 to 100.0)	% of nominal
11	Ib Angle	2	-18,000	18,000	0.1 / (0.01 – 1.0)	0.0	degrees	0.1 / 0.01	0.5 / (0.1 to 180.0)	degrees
12	Ic Magnitude	2	0	Configurable	0.01 / (0.00001 – 10.0)	0.0	A	0.01 / 0.00001	2.0 / (0.1 to 100.0)	% of nominal
13	Ic Angle	2	-18,000	18,000	0.1 / (0.01 – 1.0)	0.0	degrees	0.1 / 0.01	0.5 / (0.1 to 180.0)	degrees
14	In Magnitude	2	0	Configurable	0.01 / (0.00001 –	0.0	A	0.01 / 0.00001	2.0 / (0.1 to 100.0)	% of nominal

1 The minimum and maximum transmitted values are the lowest and highest values that the outstation will report in DNP analog input objects. These values are integers if the outstation transmits only integers. If the outstation is

For example, a pressure sensor is able to measure 0 to 500 kPa. The outstation provides a linear conversion of the sensor's output signal to integers in the range of 0 to 25000 or floating-point values of 0 to 500.000. The sensor and outstation are used in an application where the maximum possible pressure is 380 kPa. For this input, the minimum transmitted value would be stated as 0 / 0.0 and the maximum transmitted value would be stated as 19000 / 380.000.

2 The scaling information for each point specifies how data transmitted in integer variations (16 bit and 32 bit) is converted to engineering units when received by the Master (i.e. scaled according to the equation: scaled value = multiplier * raw + offset). Scaling is not applied to Floating point variations since they are already transmitted in engineering units.

3 Resolution is the smallest change that may be detected in the value due to quantization errors and is given in the units shown in the previous column. This parameter does not represent the accuracy of the measurement.

Point Index	Name	Default Class Assigned to Events (1, 2, 3 or none)	Transmitted Value ¹		Scaling ²		Scale Units	Resolution ³ (default/ maximal)	Dead band (default / (range))	Dead band Units
			Minimum	Maximum	Multiplier (default / (range))	Offset				
					10.0)					
15	In Angle	2	-18,000	18,000	0.1 / (0.01 – 1.0)	0.0	degrees	0.1 / 0.01	0.5 / (0.1 to 180.0)	degrees
16	V1 Magnitude	2	0	Configurable	0.01 / (0.00001- 1.0)	0.0	kV	0.01 / 0.00001	2.0 / (0.1 to 100.0)	% of nominal
17	V2 Magnitude	2	0	Configurable	0.01 / (0.00001- 1.0)	0.0	kV	0.01 / 0.00001	2.0 / (0.1 to 100.0)	% of nominal
18	V0 Magnitude	2	0	Configurable	0.01 / (0.00001- 1.0)	0.0	kV	0.01 / 0.00001	2.0 / (0.1 to 100.0)	% of nominal
19	I1 Magnitude	2	0	Configurable	0.01 / (0.00001 – 10.0)	0.0	A	0.01 / 0.00001	2.0 / (0.1 to 100.0)	% of nominal
20	I2 Magnitude	2	0	Configurable	0.01 / (0.00001 – 10.0)	0.0	A	0.01 / 0.00001	2.0 / (0.1 to 100.0)	% of nominal
21	I0 Magnitude	2	0	Configurable	0.01 / (0.00001 – 10.0)	0.0	A	0.01 / 0.00001	2.0 / (0.1 to 100.0)	% of nominal
22	Real Power	2	0	Configurable	0.001 / (0.00001 – 1.0)	0.0	MW	0.001 / 0.00001	4.0 / (0.1 to 100.0)	% of nominal
23	Reactive Power	2	0	Configurable	0.001 / (0.00001 – 1.0)	0.0	MVAr	0.001 / 0.00001	4.0 / (0.1 to 100.0)	% of nominal
24	Frequency	2	0	Max F x 100	0.01 / (0.01 – 1.0)	0.0	Hz	0.01 / 0.01	0.05 / (0.01 to 50.0 / 60.0)	Hz
25	Power Factor	2	0	1,000	0.01 / (0.001 – 0.1)	0.0	N/A	0.01 / 0.001	5.0 / (1.0 to 100.0)	% of nominal
26	Thermal State	2	0	10,000	0.1 / (0.01 – 1.0)	0.0	%	0.1 / 0.01	1.0 / (0.1 to 100.0)	% of nominal
27	I2t Accumulated	2	0	Configurable	1.0 / (0.1 – 10.0)	0.0	kA^2s	1.0 / 0.1	1000.0 / (0.1 to 99999.9)	kA^2s
28	I2t for Last Operation	2	0	Configurable	1.0 / (0.1 – 10.0)	0.0	kA^2s	1.0 / 0.1	100.0 / (0.1 to 99999.9)	kA^2s

1.12 OCTET STRING POINTS Static (Steady-State) Group Number: 110 Event Group Number: 111	Capabilities	Current Value	If configurable, list methods
1.12.1 Event reporting mode *:	<input type="checkbox"/> Only most recent <input type="checkbox"/> All events	Not supported	
1.12.2 Octet Strings Included in Class 0 response:	<input type="checkbox"/> Always <input type="checkbox"/> Never <input type="checkbox"/> Only if point is assigned to Class 1, 2, or 3 <input type="checkbox"/> Based on point Index (add column to table below)	Not supported	
1.12.3 Definition of Octet String Point List:	<input type="checkbox"/> Fixed, list shown in table below <input type="checkbox"/> Configurable (current list may be shown in table below) <input type="checkbox"/> Other, explain <u>Used for Event Log access as described below</u>		

* Object 110 and 111 are Octet String Object used to provide access to the Event Log text of the relay. Object 110 always contains the most recent event in the relay. Object 111 is the corresponding change event object. As stated in the DNP specifications, the variation of the response object represents the length of the string. The string represents the ASCII values of the event text.

Implementation Table

The following implementation table identifies which object groups and variations, function codes and qualifiers the device supports in both requests and responses. The *Request* columns identify all requests that may be sent by a Master, or all requests that must be parsed by an Outstation. The *Response* columns identify all responses that must be parsed by a Master, or all responses that may be sent by an Outstation.

NOTE	The implementation table must list all functionality required by the device whether Master or Outstation as defined within the DNP3 IED Conformance Test Procedures. Any functionality beyond the highest subset level supported is indicated by highlighted rows. Any Object Groups not provided by an outstation or not processed by a Master are indicated by strike through (note these Object Groups will still be parsed).
-------------	---

DNP OBJECT GROUP & VARIATION			REQUEST Outstation parses		RESPONSE Outstation can issue	
Group Num	Var Num	Description	Function Codes (dec)	Qualifier Codes (hex)	Function Codes (dec)	Qualifier Codes (hex)
1	0	Binary Input – Any Variation	1 (read)	06 (no range, or all) 00, 01 (start-stop) 07, 08 (limited qty) 17, 28 (index)	129 (response)	00, 01 (start-stop)
1	1	Binary Input – Packed format	1 (read)	06 (no range, or all) 00, 01 (start-stop) 07, 08 (limited qty) 17, 28 (index)	129 (response)	00, 01 (start-stop)
1	2	Binary Input – With flags	1 (read)	06 (no range, or all) 00, 01 (start-stop) 07, 08 (limited qty) 17, 28 (index)	129 (response)	00, 01 (start-stop)
2	0	Binary Input Event – Any Variation	1 (read)	06 (no range, or all) 07, 08 (limited qty)	129 (response)	17, 28 (index)
2	1	Binary Input Event – Without time	1 (read)	06 (no range, or all) 07, 08 (limited qty)	129 (response) 130 (unsol. resp)	17, 28 (index)
2	2	Binary Input Event – With absolute time	1 (read)	06 (no range, or all) 07, 08 (limited qty)	129 (response) 130 (unsol. resp)	17, 28 (index)
2	3	Binary Input Event – With relative time	1 (read)	06 (no range, or all) 07, 08 (limited qty)	129 (response) 130 (unsol. resp)	17, 28 (index)
10	0	Binary Output – Any Variation	1 (read)	06 (no range, or all) 00, 01 (start-stop) 07, 08 (limited qty) 17, 28 (index)	129 (response)	00, 01 (start-stop)
10	2	Binary Output – Output Status with flag	1 (read)	06 (no range, or all) 00, 01 (start-stop) 07, 08 (limited qty) 17, 28 (index)	129 (response)	00, 01 (start-stop)
12	1	Binary Command – Control relay output block (CROB)	3 (select) 4 (operate) 5 (direct op) 6 (dir. op, no ack)	17, 28 (index)	129 (response)	Echo of request
20	0	Counter – Any Variation	1 (read) 7 (freeze) 8 (freeze noack)	06 (no range, or all)	129 (response)	

DNP OBJECT GROUP & VARIATION			REQUEST Outstation parses		RESPONSE Outstation can issue	
Group Num	Var Num	Description	Function Codes (dec)	Qualifier Codes (hex)	Function Codes (dec)	Qualifier Codes (hex)
			9 (freeze clear) 10 (frz. cl. noack)			
20	1	Counter—32-bit with flag			129 (response)	00, 01 (start-stop)
20	2	Counter—16-bit with flag			129 (response)	00, 01 (start-stop)
20	5	Counter—32-bit without flag			129 (response)	00, 01 (start-stop)
20	6	Counter—16-bit without flag			129 (response)	00, 01 (start-stop)
21	0	Frozen Counter—Any Variation	1 (read)	06 (no range, or all)		
21	1	Frozen Counter—32-bit with flag			129 (response)	00, 01 (start-stop)
21	2	Frozen Counter—16-bit with flag			129 (response)	00, 01 (start-stop)
21	9	Frozen Counter—32-bit without flag			129 (response)	00, 01 (start-stop)
21	10	Frozen Counter—16-bit without flag			129 (response)	00, 01 (start-stop)
22	0	Counter Event—Any Variation	1 (read)	06 (no range, or all) 07, 08 (limited qty)		
22	1	Counter Event—32-bit with flag			129 (response) 130 (unsol. resp)	17, 28 (index)
22	2	Counter Event—16-bit with flag			129 (response) 130 (unsol. resp)	17, 28 (index)
30	0	Analog Input—Any Variation	1 (read)	06 (no range, or all) 00, 01 (start-stop) 07, 08 (limited qty) 17, 28 (index)	129 (response)	00, 01 (start-stop)
30	1	Analog Input—32-bit with flag	1 (read)	06 (no range, or all) 00, 01 (start-stop) 07, 08 (limited qty) 17, 28 (index)	129 (response)	00, 01 (start-stop)
30	2	Analog Input—16-bit with flag	1 (read)	06 (no range, or all) 00, 01 (start-stop) 07, 08 (limited qty) 17, 28 (index)	129 (response)	00, 01 (start-stop)
30	3	Analog Input—32-bit without flag	1 (read)	06 (no range, or all) 00, 01 (start-stop) 07, 08 (limited qty) 17, 28 (index)	129 (response)	00, 01 (start-stop)
30	4	Analog Input—16-bit without flag	1 (read)	06 (no range, or all) 00, 01 (start-stop) 07, 08 (limited qty) 17, 28 (index)	129 (response)	00, 01 (start-stop)
32	0	Analog Input Event—Any Variation	1 (read)	06 (no range, or all) 07, 08 (limited qty)	129 (response)	17, 28 (index)
32	1	Analog Input Event—32-bit without time	1 (read)	06 (no range, or all) 07, 08 (limited qty)	129 (response) 130 (unsol. resp)	17, 28 (index)
32	2	Analog Input Event—16-bit without time	1 (read)	06 (no range, or all) 07, 08 (limited qty)	129 (response) 130 (unsol. resp)	17, 28 (index)
32	3	Analog Input Event—32-bit with time	1 (read)	06 (no range, or all) 07, 08 (limited qty)	129 (response)	17, 28 (index)
32	4	Analog Input Event—16-bit with time	1 (read)	06 (no range, or all) 07, 08 (limited qty)	129 (response)	17, 28 (index)

40	0	Analog Output Status—Any Variation	1 (read)	06 (no range, or all)	129 (response)	
40	2	Analog Output Status—16-bit with flag			129 (response)	00, 01 (start-stop)
41	2	Analog Output—16-bit	3 (select) 4 (operate) 5 (direct op) 6 (dir. op, no ack)	17, 28 (index)	129 (response)	Echo of request
50	1	Time and Date—Absolute time	2 (write)	07 (limited qty = 1)	129 (response)	
51	1	Time and Date CTO—Absolute time, synchronized			129 (response) 130 (unsol. resp)	07 (limited qty) (qty = 1)
51	2	Time and Date CTO—Absolute time, unsynchronized			129 (response) 130 (unsol. resp)	07 (limited qty) (qty = 1)
52	1	Time Delay—Coarse			129 (response)	07 (limited qty) (qty = 1)
52	2	Time delay—Fine			129 (response)	07 (limited qty) (qty = 1)
60	1	Class Objects—Class 0 data	1 (read)	06 (no range, or all)	129 (response)	00, 01 (start-stop)
60	2	Class Objects—Class 1 data	1 (read)	06 (no range, or all)	129 (response)	17, 28 (index)
60	3	Class Objects—Class 2 data	1 (read)	06 (no range, or all)	129 (response)	17, 28 (index)
60	4	Class Objects—Class 3 data	1 (read)	06 (no range, or all)	129 (response)	17, 28 (index)
80	1	Internal Indications—Packet format	2 (write)	00 (start-stop) (index = 7)	129 (response)	
110	0	Octet string	1 (read)	06 (no range, or all)	129 (response)	07 (limited qty)
111	0	Octet string event	1 (read)	06 (no range, or all)	129 (response)	07 (limited qty)
No Object (function code only)			13 (cold restart)		129 (response)	
No Object (function code only)			14 (warm restart)		129 (response)	
No Object (function code only)			23 (delay meas.)		129 (response)	

Appendix H Mechanical Drawings

H.1 Front View



H.2 Rear View

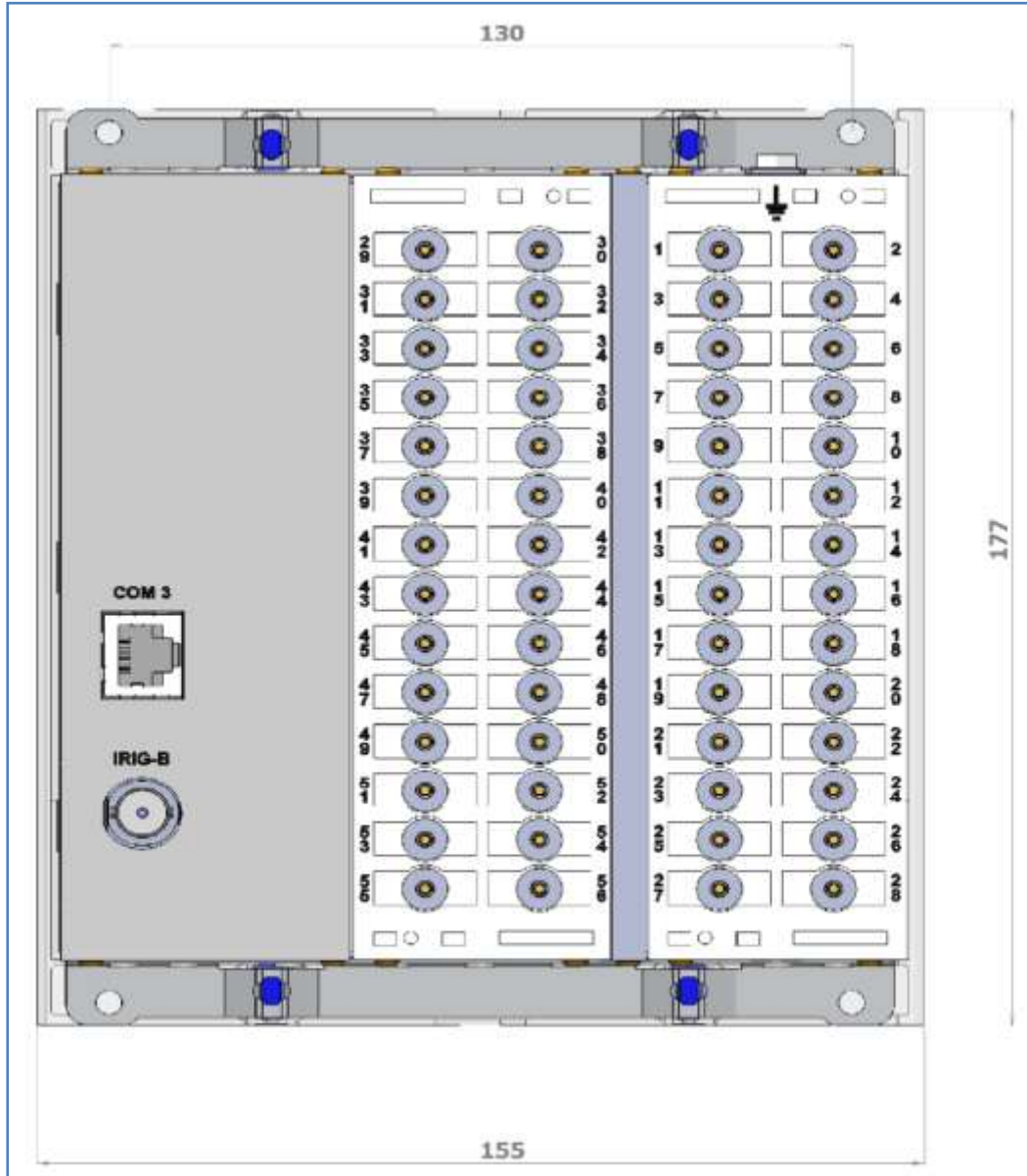

Appendix I AC Schematic Drawing

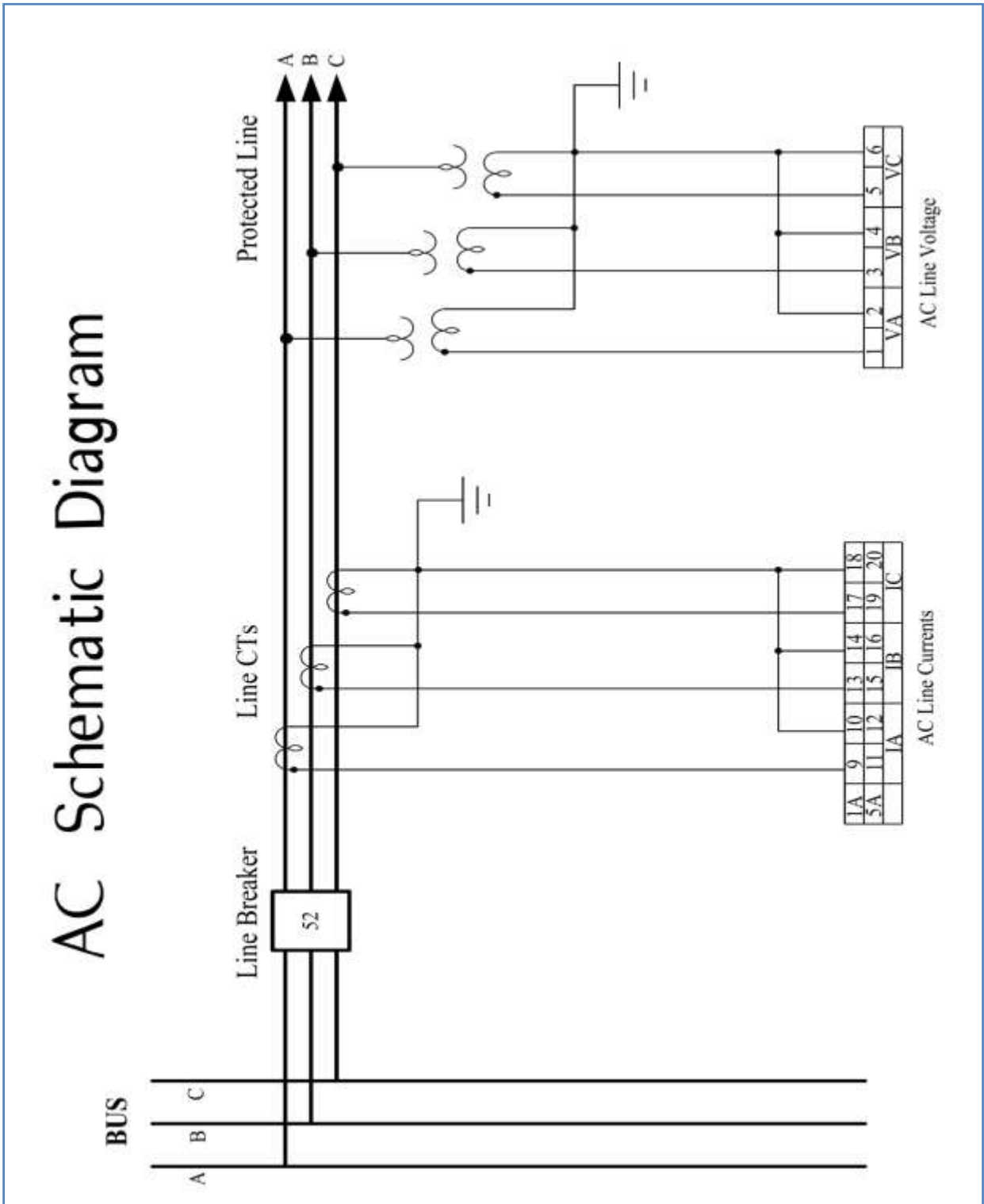

Appendix J DC Schematic Drawing

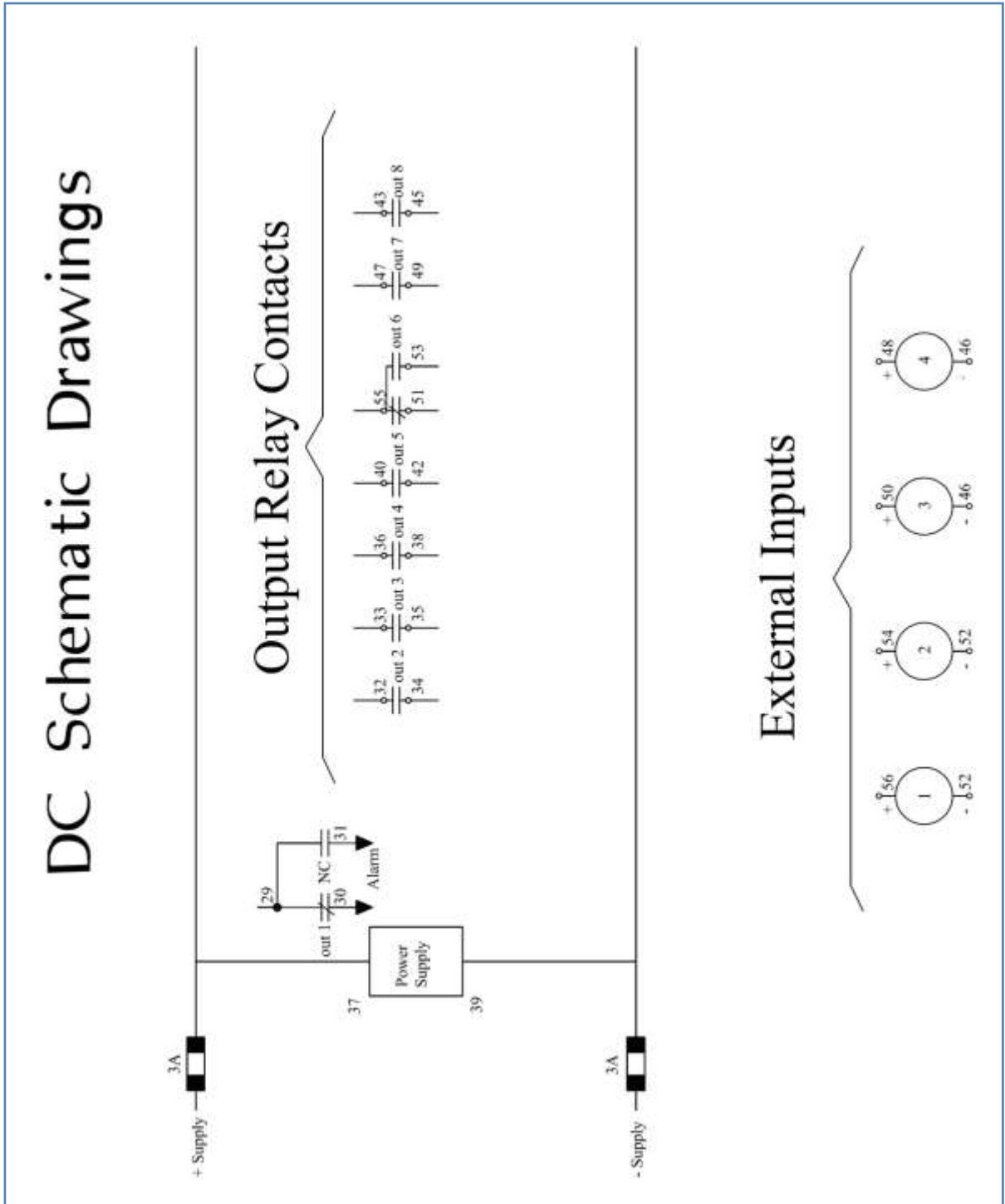

Appendix K Function Logic Diagram

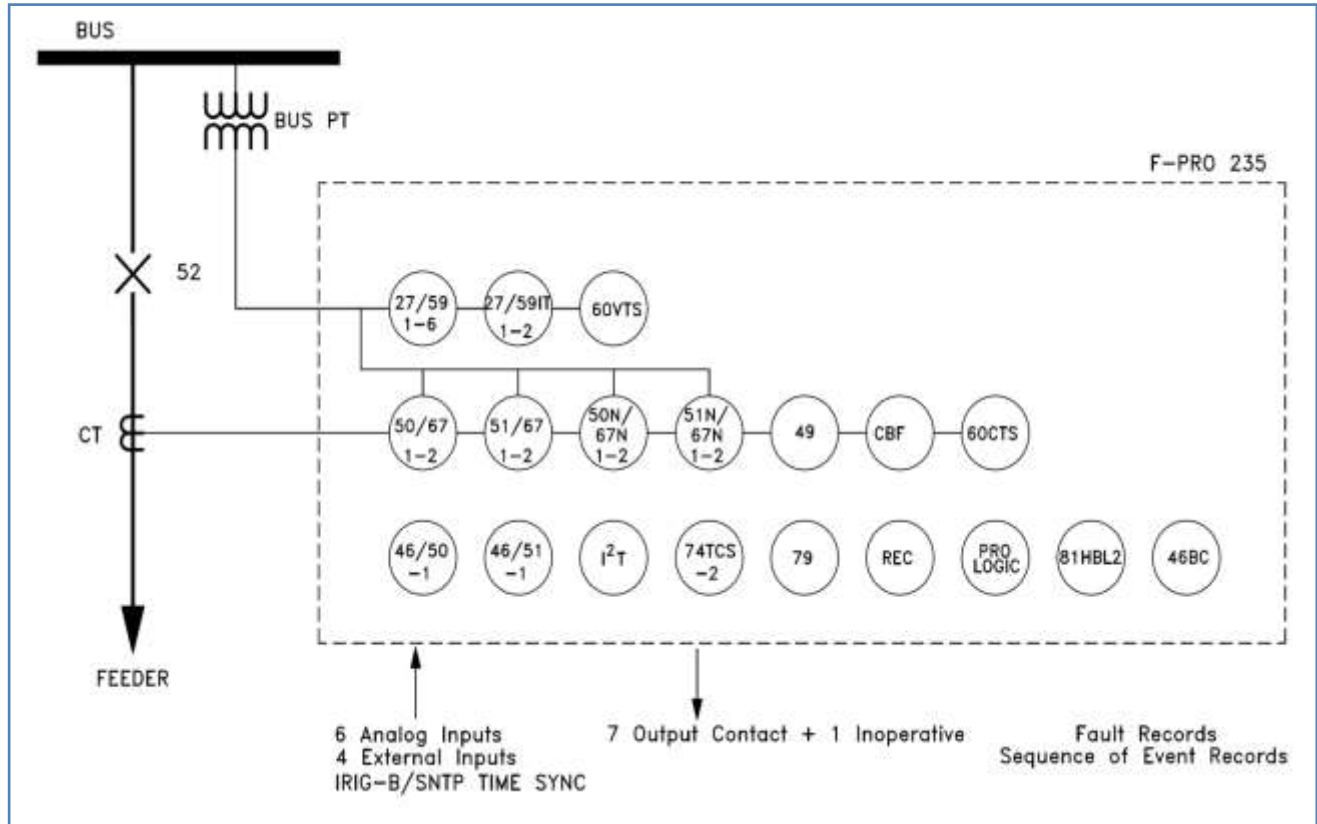

Appendix L Connection Diagram

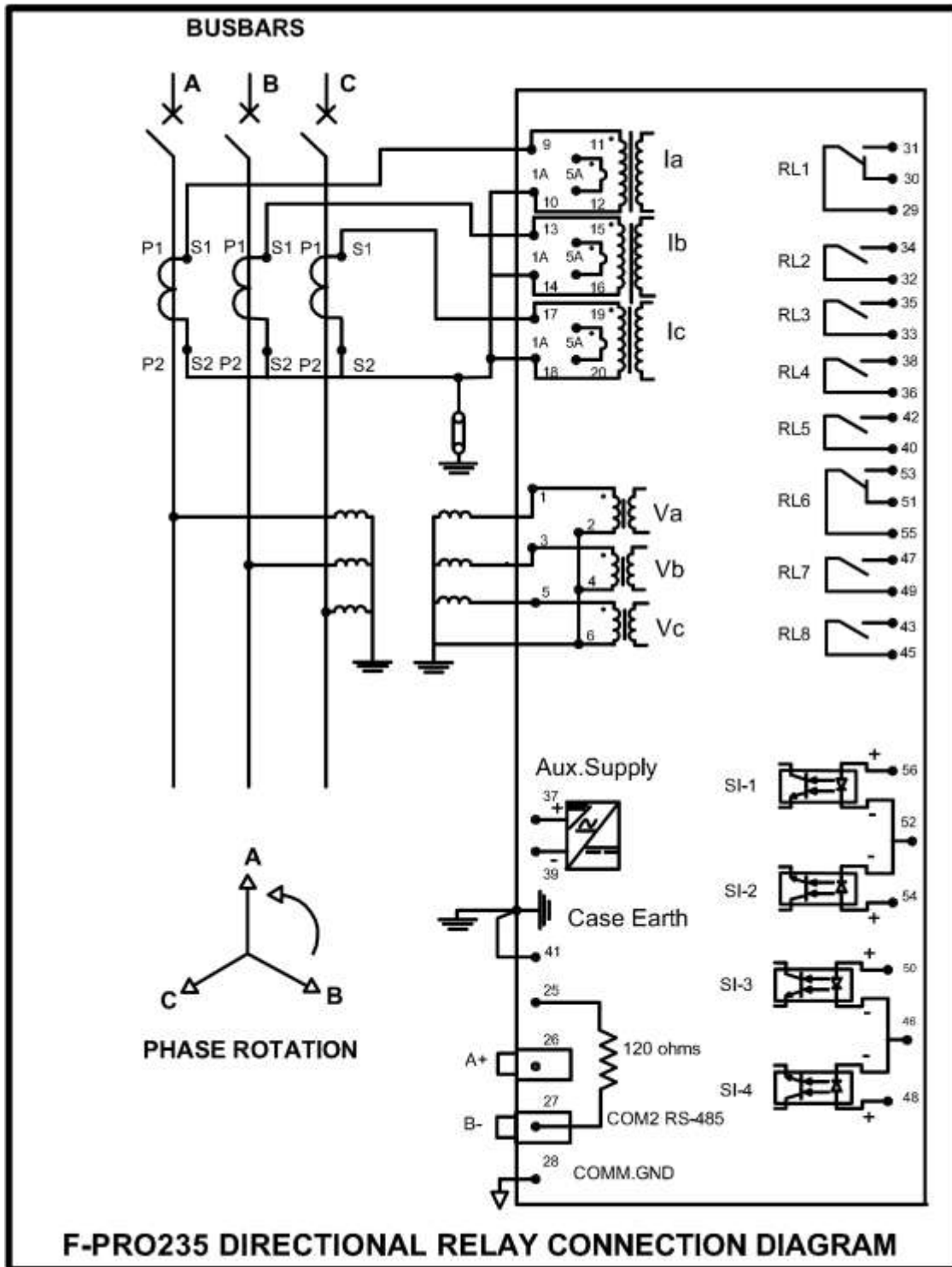

Appendix-M F-PRO Setting Example

Protection, Timers and I/O Status

The relay does not block any protection functions or external inputs during the setting save or active group change, but the external output contacts are reset for one cycle.

The relay applies the setting parameters, resets all protection functions, resets all timers and continues to process the protection algorithms but does not apply any action to the output contacts for one cycle. For close -in (heavy) fault conditions that occur at the time of a setting change the relay performance has a maximum increase in output delay of one cycle. For light fault conditions the relay performance does not have a noticeable change. There is normally a one cycle decision making process. The relay algorithms have been processing and when the one cycle blocking ends and the contacts are closed immediately.

Latch Status

The relay does not reset any ProLogic or Virtual Input latch functions during the setting save or active group change. Retaining latch status allows the relay continuous access to specific latched logic states. This is useful when the relay has ProLogic, Group Logic or Virtual Input functions used to block protection or ancillary functions for specific operating conditions.

Event Status Reset

The relay resets all the events that are currently high and reports states of all the events that remain high after a setting change.

Viewing Active Setting Group

To view active setting group via the RCP, go to *Utilities > Setting Group*. It is configurable only through Service/Change access level.

Front Panel Active Setting Group

View the active setting group with the relay front panel display. The active setting group can be changed through the front panel of the relay.

To view the active setting group enter

View>Configuration>Setting Group> Active

The same can be changed when accessed through Change or Service access

level only. We can also edit and/or view the other setting groups while active setting group is different.

Failure Modes

A – DSP System Fail:

When a DSP system fails, the relay functional LED (Green) goes OFF. The RL1 (Form C) contact on the rear panel closes to activate a remote alarm. All other contacts are forced inactive. The relay restarts automatically and becomes functional, which lit up functional LED (Green) and opens RL1.

B – Microprocessor Self-Check Fail:

The software watchdog monitors all the modules and if one or more modules fail(s), the processor restarts the Relay. At this moment, the relay functional LED goes OFF and RL1 (Form C) contact on the rear panel closes to activate a remote alarm. The relay restarts automatically and becomes functional, which lit up functional LED (Green) and opens RL1.

Appendix N IEC 61850 Data Mapping Specifications

This chapter describes IEC 61850 logical devices and nodes defined in ICD file of F-PRO 235 relay.

N.1 Protocol Implementation Conformance Statement (PICS)

Introduction

General

The following ACSI conformance statements are used to provide an overview and details about <FPRO, Feeder Protection System>, with firmware <V1.0>:

- ACSI basic conformance statement,
- ACSI models conformance statement,
- ACSI service conformance statement

The statements specify the communication features mapped to IEC 61850-8-1.

ACSI basic conformance statement

The basic conformance statement is defined in Table N.1.

Table N.1 – Basic conformance statement

		Client/ Subscriber	Server/ Publisher	Value/ Comments
Client-Server roles				
B11	Server side (of TWO-PARTY-APPLICATION-ASSOCIATION)	—	Y	
B12	Client side of (TWO-PARTY-APPLICATION-ASSOCIATION)	—	N	
SCSMs supported				
B21	SCSM: IEC 6185-8-1 used	—	Y	
B22	SCSM: IEC 6185-9-1 used	—	N	

		Client/ Subscriber	Server/ Publisher	Value/ Comments
B23	SCSM: IEC 6185-9-2 used	—	N	
B24	SCSM: other	—	N	
Generic substation event model (GSE)				
B31	Publisher side	—	Y	
B32	Subscriber side	—	Y	
Transmission of sampled value model (SVC)				
B41	Publisher side	—	N	
B42	Subscriber side	—	N	
– Y = supported N or empty = not supported				

ACSI models conformance statement

The ACSI models conformance statement is defined in Table N.2.

Table N.2 – ACSI models conformance statement

		Client/ Subscriber	Server/ Publisher	Value/ Comments
If Server or Client side (B11) supported				
M1	Logical device		Y	
M2	Logical node		Y	
M3	Data		Y	
M4	Data set		Y	
M5	Substitution		N	
M6	Setting group control		N	
	Reporting			
M7	Buffered report control		Y	

		Client/ Subscriber	Server/ Publisher	Value/ Comments
M7-1	sequence-number		Y	
M7-2	report-time-stamp		Y	
M7-3	reason-for-inclusion		Y	
M7-4	data-set-name		Y	
M7-5	data-reference		Y	
M7-6	buffer-overflow		Y	
M7-7	entryID		Y	
M7-8	BufTm		Y	
M7-9	IntgPd		Y	
M7-10	GI		Y	
M8	Unbuffered report control		Y	
M8-1	sequence-number		Y	
M8-2	report-time-stamp		Y	
M8-3	reason-for-inclusion		Y	
M8-4	data-set-name		Y	
M8-5	data-reference		Y	
M8-6	BufTm		Y	
M8-7	IntgPd		Y	
M8-8	GI		Y	
	Logging		N	
M9	Log control		N	
M9-1	IntgPd		N	
M10	Log		N	
M11	Control		N	
If GSE (B31/32) is supported				
M12	GOOSE		Y	
M12-1	entryID		Y	

M12-2	DataRefInc		Y	
M13	GSSE		N	
If SVC (B41/42) is supported				
M14	Multicast SVC		N	
M15	Unicast SVC		N	
If Server or Client side (B11/12) supported				
M16	Time		Y	
M17	File Transfer		Y	
Y = service is supported N or empty = service is not supported				

ACSI service conformance statement

The ACSI service conformance statement is defined in Table N.3 (depending on the statements in Table N.1).

Table N.3 – ACSI service Conformance statement

	Services	AA: TP/M C	Client (C)	Server (S)	Comments
Server (Clause 6)					
S1	ServerDirectory	TP		Y	

Application association (Clause 7)					
S2	Associate			Y	
S3	Abort			Y	
S4	Release			Y	

Logical device (Clause 8)					
S5	LogicalDeviceDirectory	TP		Y	

	Services	AA: TP/M C	Client (C)	Server (S)	Comments
--	----------	------------------	------------	------------	----------

Logical node (Clause 9)					
S6	LogicalNodeDirectory	TP		Y	
S7	GetAllDataValues	TP		Y	

Data (Clause 10)					
S8	GetDataValues	TP		Y	
S9	SetDataValues	TP		N	
S10	GetDataDirectory	TP		Y	
S11	GetDataDefinition	TP		Y	

Data set (Clause 11)					
S12	GetDataSetValues	TP		Y	
S13	DataSetValues	TP		N	
S14	CreateDataSet	TP		N	
S15	DeleteDataSet	TP		N	
S16	GetDataSetDirectory	TP		Y	

Substitution (Clause 12)					
S17	SetDataValues	TP		N	

Setting group control (Clause 13)					
S18	SelectActiveSG	TP		N	
S19	SelectEditSG	TP		N	
S20	SetSGValues	TP		N	
S21	ConfirmEditSGValues	TP		N	
S22	GetSGValues	TP		Y	

S23	GetSGCBValues	TP		N	
-----	---------------	----	--	---	--

Reporting (Clause 14)					
Buffered report control block (BRCB)					
S24	Report	TP		Y	
S24-1	data-change (dchg)			Y	
S24-2	quality-change (qchg)			N	
S24-3	data-update (dupd)			N	
S25	GetBRCBValues	TP		Y	
S26	SetBRCBValues	TP		Y	
Unbuffered report control block (URCB)					
S27	Report	TP		Y	
S27-1	data-change (dchg)			Y	
S27-2	quality-change (qchg)			N	
S27-3	data-update (dupd)			N	
S28	GetURCBValues	TP		Y	
S29	SetURCBValues	TP		Y	

Logging (Clause 14)					
Log control block					
S30	GetLCBValues	TP		N	
S31	SetLCBValues	TP		N	
Log					
S32	QueryLogByTime	TP		N	
S33	QueryLogAfter	TP		N	

S34	GetLogStatusValues	TP		N	
-----	--------------------	----	--	---	--

Generic substation event model (GSE)					
GOOSE-CONTROL-BLOCK					
S35	SendGOOSEMessage	MC		Y	
S36	GetGoReference	TP		N	
S37	GetGOOSEElementNumber	TP		N	
S38	GetGoCBValues	TP		Y	
S39	SetGoCBValues	TP		Y	
GSSE-CONTROL-BLOCK					
S40	SendGSSEMessage	MC		N	
S41	GetReference	TP		N	
S42	GetGSSEElementNumber	TP		N	
S43	GetGsCBValues	TP		N	
S44	SetGsCBValues	TP		N	

Transmission of sampled value model (SVC) (Clause 16)					
Multicast SVC					
S45	SendMSVMessage	MC		N	
S46	GetMSVCBValues	TP		N	
S47	SetMSVCBValues	TP		N	
Unicast SVC					
S48	SendUSVMessage	TP		N	
S49	GetUSVCBValues	TP		N	
S50	SetUSVCBValues	TP		N	

Control

S51	Select			N	
S52	SelectWithValue	TP		N	
S53	Cancel	TP		N	
S54	Operate	TP		N	
S55	CommandTermination	TP		N	
S56	TimeActivatedOperate	TP		N	

File transfer (Clause 20)					
S57	GetFile	TP		Y	
S58	SetFile	TP		Y	
S59	DeleteFile	TP		Y	
S60	GetFileAttributeValues	TP		Y	

Time					
T1	Time resolution of internal clock			10 (1 ms)	nearest negative power of 2 in seconds
T2	Time accuracy of internal clock			10 (1 ms)	T0
					T1
					T2
					T3
					T4
					T5
T3	Supported TimeStamp resolution	-		10 (1 ms)	nearest negative power of 2 in seconds

N.2 Model Implementation Conformance Statement (MICS)

Introduction

This model implementation conformance statement is applicable for FPRO, Feeder Protection System, with firmware V1.0.

This MICS document specifies the modelling extensions compared to IEC 61850 edition 1. For the exact details on the standardized model please compare the ICD substation configuration file: "ERLFPRO2xx.icd", Version V1.0

Clause 2 contains the list of implemented logical nodes.

Clause 3 describes the new and extended logical nodes.

Logical Nodes List

The following table contains the list of logical nodes implemented in the device:

L: System Logical Nodes
LPHD (Physical device information)
LLNO (Logical node zero)
P: Logical Nodes for protection functions
PTUV (Undervoltage)
PTOV (Overvoltage)
PVPH (Volts per Hz)
NPTOV (Derived residual over voltage)
PIOC (Instantaneous overcurrent)

PTOC (Time overcurrent)
NPIOC (Instantaneous neutral overcurrent)
NPTOC (Time neutral overcurrent)
PTTR (Thermal overload)
PHAR (Harmonic restraint)
R: Logical nodes for protection related functions
RBRF (Breaker failure)
RREC (Autoreclosing)
RBCD (Broken conductor detection)
RVTS (VT supervision)
RCTS (CT supervision)
RTCS (Trip circuit supervision)
RCBC (Circuit breaker condition)
G: Logical Nodes for generic references
GGIO (Generic process I/O)
M: Logical Nodes for metering and measurement
MMXU (Measurement)
MSQI (Sequene and imbalance)

Logical Node Extensions

The following table use

- M : Data is mandatory in the IEC-61850-7-4.
- O: Data is optional in the IEC-61850-7-4 and is used in the device.
- E: Data is an extension to the IEC-61850-7-4.

New Logical Explanation

New logical nodes have the descriptions in the Name plate.

LPHD

LN class				
Attribute	Attribute Type	Explanation	M/O/E	Remarks
LPHD1		Physical device information		
Data				
Common Logical Node Information				
Attribute	Attribute Type	Explanation	M/O/E	
phyHealth	INS_2_ phyHealth	Physical device health	M	
proxy	SPS_1_Proxy	Indicate if this device is proxy	M	
phyNam	DPL_2_phyNam	Device physical name plate	M	

LLNO

LN class				
Attribute	Attribute Type	Explanation	M/O/E	Remarks
LLNO		Logic node 0		
Data				
Common Logical Node Information				
Attribute	Attribute Type	Explanation	M/O/E	
Mod	INC	Mode	M	Mod
Beh	INS	Behaviour	M	Beh
Health	INS	Health	M	Health
NamPlt	LPL	Name plate	M	NamPlt

PHAR Harmonic Restraint

LN class				
Attribute	Attribute Type	Explanation	M/O/E	Remarks
D81H2PHAR		Inrush blocking		
Data				
Common Logical Node Information				
Attribute	Attribute Type	Explanation	M/O/E	

Mod	INC	Mode	M	
Beh	INS	Behaviour	M	
Health	INS	Health	M	
NamPlt	LPL	Name plate	M	
Status Information				
Str	ACD	81HBL2 inrush operated	M	

PTTR Thermal Overload

LN class				
Attribute	Attribute Type	Explanation	M/O/E	Remarks
D49PTTR		Thermal overload		
Data				
Common Logical Node Information				
Attribute	Attribute Type	Explanation	M/O/E	
Mod	INC	Mode	M	
Beh	INS	Behaviour	M	
Health	INS	Health	M	
NamPlt	LPL	Name plate	M	

Status Information				
Str	ACD	49- Pickedup	O	
Op	ACT	49 – Operated	M	
ALm Thm	ACT	49 Alarm Operated	O	

NPIOC Instantaneous Neutral Overcurrent

LN class				
Attribute	Attribute Type	Explanation	M/O/E	Remarks
D50NPIOC		Instantaneous neutral overcurrent		
Data				
Common Logical Node Information				
Attribute	Attribute Type	Explanation	M/O/E	
Mod	INC	Mode	M	
Beh	INS	Behaviour	M	
Health	INS	Health	M	
NamPlt	LPL	Name plate	M	
Status Information				
Str	ACD	50N- Pickedup	O	
Op	ACT	50N – Operated	M	

NPTOC Time Neutral Overcurrent

LN class				
Attribute	Attribute Type	Explanation	M/O/E	Remarks
D51NPTOC		Time neutral overcurrent		
Data				
Common Logical Node Information				
Attribute	Attribute Type	Explanation	M/O/E	
Mod	INC	Mode	M	
Beh	INS	Behaviour	M	
Health	INS	Health	M	
NamPlt	LPL	Name plate	M	
Status Information				
Str	ACD	51N- Pickedup	M	
Op	ACT	51N – Operated	M	

PTOC Time Over Current

LN class				
Attribute	Attribute Type	Explanation	M/O/E	Remarks
D51PTOC		IDMTL phase over current		
Data				
Common Logical Node Information				
Attribute	Attribute Type	Explanation	M/O/E	
Mod	INC	Mode	M	
Beh	INS	Behaviour	M	
Health	INS	Health	M	
NamPlt	LPL	Name plate	M	
Status Information				
Str	ACD	51- Pickedup	M	
Op	ACT	51 – Operated	M	

PIOC Instantaneous Over Current

LN class				
Attribute	Attribute Type	Explanation	M/O/E	Remarks
D50PIOC		Instantaneous phase over current		
Data				
Common Logical Node Information				
Attribute	Attribute Type	Explanation	M/O/E	
Mod	INC	Mode	M	
Beh	INS	Behaviour	M	
Health	INS	Health	M	
NamPlt	LPL	Name plate	M	
Status Information				
Str	ACD	50- Pickedup	O	
Op	ACT	50 – Operated	M	

PTOV Over Voltage

LN class				
Attribute	Attribute Type	Explanation	M/O/E	Remarks
DT59PTOV		Over Voltage		
Data				
Common Logical Node Information				
Attribute	Attribute Type	Explanation	M/O/E	
Mod	INC	Mode	M	
Beh	INS	Behaviour	M	
Health	INS	Health	M	
NamPlt	LPL	Name plate	M	
Status Information				
Str	ACD	59DT-Over Voltage Pickedup	M	
Op	ACT	59DT – Over Voltage Operated	O	

PTUV Under Voltage

LN class				
Attribute	Attribute Type	Explanation	M/O/E	Remarks
DT27PTUV		Under voltage		
Data				
Common Logical Node Information				
Attribute	Attribute Type	Explanation	M/O/E	
Mod	INC	Mode	M	
Beh	INS	Behaviour	M	
Health	INS	Health	M	
NamPlt	LPL	Name plate	M	
Status Information				
Str	ACD	27DT-Under Voltage Pickedup	M	
Op	ACT	27DT – Under Voltage Operated	M	

RBCD Broken Conductor Detection

LN class				
Attribute	Attribute Type	Explanation	M/O/E	Remarks
D46BCRBCD		Broken conductor detection		
Data				
Common Logical Node Information				
Attribute	Attribute Type	Explanation	M/O/E	
Mod	INC	Mode	M	
Beh	INS	Behaviour	M	
Health	INS	Health	M	
NamPlt	LPL	Name plate	M	
Status Information				
Op	ACT	46BC - Broken Conductor Operated	E	

RBRF Breaker Failure

LN class				
Attribute	Attribute Type	Explanation	M/O/E	Remarks
D50BFRBRF		Breaker failure		
Data				
Common Logical Node Information				
Attribute	Attribute Type	Explanation	M/O/E	
Mod	INC	Mode	M	
Beh	INS	Behaviour	M	
Health	INS	Health	M	
NamPlt	LPL	Name plate	M	
Status Information				
OpEx	ACT	50BF delay2 Operated	C	
OpIn	ACT	50BF delay1 Operated	C	

RREC Auto Reclose

LN class				
Attribute	Attribute Type	Explanation	M/O/E	Remarks
D79RREC		Multi shot auto reclose		
Data				
Common Logical Node Information				
Attribute	Attribute Type	Explanation	M/O/E	
Mod	INC	Mode	M	
Beh	INS	Behaviour	M	
Health	INS	Health	M	
NamPlt	LPL	Name plate	M	
Status Information				
Auto	ACT	79IN External Switch Status	O	
Op	ACT	79 Auto reclosure Operated	M	
AuroRecSt	ACT	79AR Lockout Information	M	
BlkRec	ACT	79AR Block	O	

RVTS VT Supervision

LN class				
Attribute	Attribute Type	Explanation	M/O/E	Remarks
D60VTRVTS		VT supervision		
Data				
Common Logical Node Information				
Attribute	Attribute Type	Explanation	M/O/E	
Mod	INC	Mode	M	
Beh	INS	Behaviour	M	
Health	INS	Health	M	
NamPlt	LPL	Name plate	M	
Status Information				
Op	ACT	60VTS Fail Operated	E	

RCTS CT Supervision

LN class				
Attribute	Attribute Type	Explanation	M/O/E	Remarks
D60CTRCTS		CT supervision		
Data				
Common Logical Node Information				
Attribute	Attribute Type	Explanation	M/O/E	
Mod	INC	Mode	M	
Beh	INS	Behaviour	M	
Health	INS	Health	M	
NamPlt	LPL	Name plate	M	
Status Information				
Op	ACT	60CTS Operated	E	

RTCS Trip Circuit Supervision

LN class				
Attribute	Attribute Type	Explanation	M/O/E	Remarks
D74TCSRTCS		Trip circuit supervision		
Data				
Common Logical Node Information				
Attribute	Attribute Type	Explanation	M/O/E	
Mod	INC	Mode	M	
Beh	INS	Behaviour	M	
Health	INS	Health	M	
NamPlt	LPL	Name plate	M	
Status Information				
Op	ACT	74TCS Operated	E	

RCBC Circuit Breaker Condition

LN class				
Attribute	Attribute Type	Explanation	M/O/E	Remarks
I2TRCBC		Circuit breaker condition		
Data				
Common Logical Node Information				
Attribute	Attribute Type	Explanation	M/O/E	
Mod	INC	Mode	M	
Beh	INS	Behaviour	M	
Health	INS	Health	M	
NamPlt	LPL	Name plate	M	
Measured Values				
I2TAcc	MV	I2T Accumulated	E	
I2TLstOp	MV	I2T Value - Last Operation	E	
Status Information				
Op	ACT	I2T Operated	E	

MMXU1

LN class				
Attribute	Attribute Type	Explanation	M/O/E	Remarks
ANAMMX U1		Physical device information		
Data				
Common Logical Node Information				
Attribute	Attribute Type	Explanation	M/O/E	
Mod	INC_2_Mod	Mode	M	
Beh	INS_1_Beh	Behaviour	M	
Health	INS_1_Health	Health	M	
NamPlt	LPL_4_NamPlt	Name Plate	M	
TotW	MV_1_TotW	Total Active Power (Total P)	M	
TotVAr	MV_1_TotW	Total Reactive Power (Total Q)	M	
TotPF	MV_1_TotW	Average Power Factor (Total PF)	M	
Hz	MV_1_TotW	Frequency	M	
PhV	WYE_1_Z	Phase to Ground Voltage	M	
A	WYE_1_Z	Phase Currents	M	

MSQI

LN class				
Attribute	Attribute Type	Explanation	M/O/E	Remarks
SEQMSQ1		Physical device information		
Data				
Common Logical Node Information				
Attribute	Attribute Type	Explanation	M/O/E	
Mod	INC_2_Mod	Mode	M	
Beh	INS_1_Beh	Behaviour	M	
Health	INS_1_Health	Health	M	
NamPlt	LPL_4_NamPlt	Name Plate	M	
SeqV	WYE_1_Z	V1,V2,V0	M	
SeqA	WYE_1_Z	I1,I2,I0	M	

N.3 Data Mapping Specifications

F-PRO logical devices

F-PRO has the following IEC 61850 logical devices (LN) defined in its ICD file:

1. Protection
2. Measurements
3. Records
4. System
5. FaultData
6. VirtualElements

F-PRO logical nodes

Below table defines the list of logical nodes (LN) for the F-PRO logical devices.

Note: System logical nodes (group L) are not shown here

LD Name	LN Name	LN Description	FPRO Protection Function Reference	Comments	Data Reference
Protection	DT27PTUV1	27-1 DTL Under Voltage	Dev 27_1	DTL Under Voltage_1	PTUV
Protection	DT27PTUV2	27-2 DTL Under Voltage	Dev 27_2	DTL Under Voltage_2	PTUV
Protection	DT27PTUV3	27-3 DTL Under Voltage	Dev 27_3	DTL Under Voltage_3	PTUV
Protection	DT27PTUV4	27-4 DTL Under Voltage	Dev 27_4	DTL Under Voltage_4	PTUV

LD Name	LN Name	LN Description	FPRO Protection Function Reference	Comments	Data Reference
Protection	DT27PTUV5	27-5 DTL Under Voltage	Dev 27_5	DTL Under Voltage_5	PTUV
Protection	DT27PTUV6	27-6 DTL Under Voltage	Dev 27_6	DTL Under Voltage_6	PTUV
Protection	IT27PTUV1	27-1 IDMTL Under Voltage	Dev 27_1	IDMTL Under Voltage_1	PTUV
Protection	IT27PTUV2	27-2 IDMTL Under Voltage	Dev 27_2	IDMTL Under Voltage_2	PTUV
Protection	DT59PTOV1	59-1 DTL Over Voltage	Dev 59_1	DTL Over Voltage_1	PTOV
Protection	DT59PTOV2	59-2 DTL Over Voltage	Dev 59_2	DTL Over Voltage_2	PTOV
Protection	DT59PTOV3	59-3 DTL Over Voltage	Dev 59_3	DTL Over Voltage_3	PTOV
Protection	DT59PTOV4	59-4 DTL Over Voltage	Dev 59_4	DTL Over Voltage_4	PTOV
Protection	DT59PTOV5	59-5 DTL Over Voltage	Dev 59_5	DTL Over Voltage_5	PTOV
Protection	DT59PTOV6	59-6 DTL Over Voltage	Dev 59_6	DTL Over Voltage_6	PTOV
Protection	IT59PTOV1	59-1 IDMTL Over Voltage	Dev 59_1	IDMTL Over Voltage_1	PTOV
Protection	IT59PTOV2	59-2 IDMTL Over Voltage	Dev 59_2	IDMTL Over Voltage_2	PTOV

LD Name	LN Name	LN Description	FPRO Protection Function Reference	Comments	Data Reference
Protection	D50PIOC1	Instantaneous Overcurrent (directional)	Dev 50/67_1	Inst. Phase Overcurrent_1	PIOC
Protection	D50PIOC2	Instantaneous Overcurrent (directional)	Dev 50/67_2	Inst. Phase Overcurrent_2	PIOC
Protection	D50NPIOC1	Instantaneous Overcurrent (directional)	Dev 50/67N_1	Inst. Phase Overcurrent_1 (Derived)	PIOC
Protection	D50NPIOC2	Instantaneous Overcurrent (directional)	Dev 50N/67_2	Inst. Phase Overcurrent_2 (Derived)	PIOC
Protection	D4650PIOC1	Instantaneous Overcurrent	Dev 46_50	Inst. Negative Sequence Overcurrent	PIOC
Protection	D51PTOC1	Time Overcurrent (directional)	Dev 51/67_1	IDMTL Phase Overcurrent	PTOC
Protection	D51PTOC2	Time Overcurrent (directional)	Dev 51/67_2	IDMTL Phase Overcurrent	PTOC
Protection	D51NPTOC1	Time Overcurrent (directional)	Dev 51/67N_1	IDMTL Neutral Overcurrent (Derived)	PTOC
Protection	D51NPTOC2	Time Overcurrent (directional)	Dev 51/67N_2	IDMTL Neutral Overcurrent (Derived)	PTOC
Protection	D4651PTOC1	Time Overcurrent	Dev 46_51	IDMTL Negative Sequence Overcurrent	PTOC
Protection	D49PTTR1	Thermal Overload	Dev 49	Thermal Overload	PTTR
Protection	D50BFRBRF1	Breaker Failure	Dev 50BF	Breaker Failure	RBRF

LD Name	LN Name	LN Description	FPRO Protection Function Reference	Comments	Data Reference
Protection	D79RREC1	Auto Reclosing	Dev 79	Auto Reclose	RREC
Protection	D81H2PHAR1	Harmonic Restraint	Dev 81HBL2	2nd Harmonic Inrush Block	PHAR
Protection	D46BCRBCD1	New LN: R-LN Group; B- Broken; C- Conductor; D- Detection	Dev 46BC	Broken Conductor Detection	RBCD
Protection	D74TCSRTCS1	New LN: R-LN Group; T-Trip; C-Circuit; S-Supervision	Dev 74TCS (for 2 stages)	Trip Circuit Supervision	RTCS
Protection	I2TRCBC1	New LN: R-LN Group; C- Circuit; B- Breaker; C- Condition	Dev I2T	CB Monitoring	RCBC
Protection	D60RVTS1	New LN: R-LN Group; V- Voltage; T-Trip; S-Supervision	Dev VTS	VT Supervision	RVTS
Protection	D60RCTS1	New LN: R-LN Group; C- Current; T-Trip; S-Supervision	Dev CTS	CT Supervision	RCTS
Protection	TRCALH1	Alarm Handling	NA	Status of Starter/Trip Elements	CALH
Measurements	ANAMMXU1	Measurements	NA	Analog Channel Input Measurement (3 Phase Current(s) & Voltage(s))	MMXU
Measurements	SEQMSQI1	Sequence & Imbalance	NA	Sequence Components of Voltage & Current (V1, V2, V0, I1,I2,I0)	MSQI

LD Name	LN Name	LN Description	FPRO Protection Function Reference	Comments	Data Reference
Records	DRRDRE1	Disturbance Recorder	Disturbance Record	Transient Records	RDRE
FaultData	FLTDATA1	New LN: DATA	NA	Fault Voltage & Current Details	DATA
System	LLNO/..(SGCB) (predefined)	Logical Node Zero	Setting Group	Used for Control of Setting Group	LLNO
System	EIGGIO1	Generic Process I/O	External Inputs	Status of External Inputs (1-4)	LLNO
System	OCGGIO1	Generic Process I/O	Output Contacts	Status of Output Contacts(1-8)	GGIO
System	PLGGIO1	Generic Process I/O	Prologics	Status of Prologics (1-20)	GGIO

LD Name	LN Name	LN Description	FPRO Protection Function Reference	Comments	Data Reference
System	LEDGGIO1	Generic Process I/O	HMI LED Monitoring	LED Status (1-8)	GGIO
System	HEALTHGGIO1	Generic Process I/O	Relay Health, IRIG-B, SNTP Monitoring	Relay Health Status (1-3)	GGIO
VirtualElements	VIGGIO1	Generic Process I/O	Virtual Input Status	Virtual Inputs Status (1-30)	GGIO
VirtualElements	VIGGIO2	Generic Process I/O	Virtual Input Control	Virtual Inputs Status (1-30)	GGIO
VirtualElements	VIGGIO3	Generic Process I/O	Virtual Outputs Control	Virtual Inputs Status (1-30)	GGIO

Logical Node Specifications

The following section provides the detailed information on each of the logical nodes for the variant FPRO 235xAy as defined in the previous section.

Logical Nodes for Protection Functions

DT27PTUV1

This section defines the logical node data of DT27PTUV1

Data Name	Description
DT27PTUV1.ST.Str.general	Start (27DT-1 Picked up)
DT27PTUV1.ST.Str.dirGeneral	Direction General
DT27PTUV1.ST.Str.phsA	Start (27DT-1 Picked up) Phase A
DT27PTUV1.ST.Str.phsB	Start (27DT-1 Picked up) Phase B
DT27PTUV1.ST.Str.phsC	Start (27DT-1 Picked up) Phase C
DT27PTUV1.ST.Op.general	Operate (27DT-1 Operated)
DT27PTUV1.ST.Op.phsA	Operate (27DT-1 Operated) Phase A
DT27PTUV1.ST.Op.phsB	Operate (27DT-1 Operated) Phase B
DT27PTUV1.ST.Op.phsC	Operate (27DT-1 Operated) Phase C

DT27PTUV2

This section defines the logical node data of DT27PTUV2

Data Name	Description
DT27PTUV2.ST.Str.general	Start (27DT-2 Picked up)
DT27PTUV2.ST.Str.dirGeneral	Direction General
DT27PTUV2.ST.Str.phsA	Start (27DT-2 Picked up) Phase A
DT27PTUV2.ST.Str.phsB	Start (27DT-2 Picked up) Phase B
DT27PTUV2.ST.Str.phsC	Start (27DT-2 Picked up) Phase C
DT27PTUV2.ST.Op.general	Operate (27DT-2 Operated)
DT27PTUV2.ST.Op.phsA	Operate (27DT-2 Operated) Phase A
DT27PTUV2.ST.Op.phsB	Operate (27DT-2 Operated) Phase B
DT27PTUV2.ST.Op.phsC	Operate (27DT-2 Operated) Phase C

DT27PTUV3

This section defines the logical node data of DT27PTUV3

Data Name	Description
DT27PTUV3.ST.Str.general	Start (27DT-3 Picked up)
DT27PTUV3.ST.Str.dirGeneral	Direction General
DT27PTUV3.ST.Str.phsA	Start (27DT-3 Picked up) Phase A
DT27PTUV3.ST.Str.phsB	Start (27DT-3 Picked up) Phase B
DT27PTUV3.ST.Str.phsC	Start (27DT-3 Picked up) Phase C
DT27PTUV3.ST.Op.general	Operate (27DT-3 Operated)
DT27PTUV3.ST.Op.phsA	Operate (27DT-3 Operated) Phase A
DT27PTUV3.ST.Op.phsB	Operate (27DT-3 Operated) Phase B
DT27PTUV3.ST.Op.phsC	Operate (27DT-3 Operated) Phase C

DT27PTUV4

This section defines the logical node data of DT27PTUV4

Data Name	Description
DT27PTUV4.ST.Str.general	Start (27DT-4 Picked up)
DT27PTUV4.ST.Str.dirGeneral	Direction General
DT27PTUV4.ST.Str.phsA	Start (27DT-4 Picked up) Phase A
DT27PTUV4.ST.Str.phsB	Start (27DT-4 Picked up) Phase B
DT27PTUV4.ST.Str.phsC	Start (27DT-4 Picked up) Phase C
DT27PTUV4.ST.Op.general	Operate (27DT-4 Operated)
DT27PTUV4.ST.Op.phsA	Operate (27DT-4 Operated) Phase A
DT27PTUV4.ST.Op.phsB	Operate (27DT-4 Operated) Phase B
DT27PTUV4.ST.Op.phsC	Operate (27DT-4 Operated) Phase C

DT27PTUV5

This section defines the logical node data of DT27PTUV5

Data Name	Description
DT27PTUV5.ST.Str.general	Start (27DT-5 Picked up)
DT27PTUV5.ST.Str.dirGeneral	Direction General
DT27PTUV5.ST.Str.phsA	Start (27DT-5 Picked up) Phase A
DT27PTUV5.ST.Str.phsB	Start (27DT-5 Picked up) Phase B
DT27PTUV5.ST.Str.phsC	Start (27DT-5 Picked up) Phase C
DT27PTUV5.ST.Op.general	Operate (27DT-5 Operated)
DT27PTUV5.ST.Op.phsA	Operate (27DT-5 Operated) Phase A
DT27PTUV5.ST.Op.phsB	Operate (27DT-5 Operated) Phase B
DT27PTUV5.ST.Op.phsC	Operate (27DT-5 Operated) Phase C

DT27PTUV6

This section defines the logical node data of DT27PTUV6

Data Name	Description
DT27PTUV6.ST.Str.general	Start (27DT-6 Picked up)
DT27PTUV6.ST.Str.dirGeneral	Direction General
DT27PTUV6.ST.Str.phsA	Start (27DT-6 Picked up) Phase A
DT27PTUV6.ST.Str.phsB	Start (27DT-6 Picked up) Phase B
DT27PTUV6.ST.Str.phsC	Start (27DT-6 Picked up) Phase C
DT27PTUV6.ST.Op.general	Operate (27DT-6 Operated)
DT27PTUV6.ST.Op.phsA	Operate (27DT-6 Operated) Phase A
DT27PTUV6.ST.Op.phsB	Operate (27DT-6 Operated) Phase B
DT27PTUV6.ST.Op.phsC	Operate (27DT-6 Operated) Phase C

IT27PTUV1

This section defines the logical node data of IT27PTUV1

Data Name	Description
IT27PTUV1.ST.Str.general	Start (27IT-1 Picked up)
IT27PTUV1.ST.Str.dirGeneral	Direction General
IT27PTUV1.ST.Str.phsA	Start (27IT-1 Picked up) Phase A
IT27PTUV1.ST.Str.phsB	Start (27IT-1 Picked up) Phase B
IT27PTUV1.ST.Str.phsC	Start (27IT-1 Picked up) Phase C
IT27PTUV1.ST.Op.general	Operate (27IT-1 Operated)
IT27PTUV1.ST.Op.phsA	Operate (27IT-1 Operated) Phase A
IT27PTUV1.ST.Op.phsB	Operate (27IT-1 Operated) Phase B
IT27PTUV1.ST.Op.phsC	Operate (27IT-1 Operated) Phase C

IT27PTUV2

This section defines the logical node data of IT27PTUV2

Data Name	Description
IT27PTUV2.ST.Str.general	Start (27IT-2 Picked up)
IT27PTUV2.ST.Str.dirGeneral	Direction General
IT27PTUV2.ST.Str.phsA	Start (27IT-2 Picked up) Phase A
IT27PTUV2.ST.Str.phsB	Start (27IT-2 Picked up) Phase B
IT27PTUV2.ST.Str.phsC	Start (27IT-2 Picked up) Phase C
IT27PTUV2.ST.Op.general	Operate (27IT-2 Operated)
IT27PTUV2.ST.Op.phsA	Operate (27IT-2 Operated) Phase A
IT27PTUV2.ST.Op.phsB	Operate (27IT-2 Operated) Phase B
IT27PTUV2.ST.Op.phsC	Operate (27IT-2 Operated) Phase C

DT59PTOV1

This section defines the logical node data of DT59PTOV1

Data Name	Description
DT59PTOV1.ST.Str.general	Start (59DT-1 Picked up)
DT59PTOV1.ST.Str.dirGeneral	Direction General
DT59PTOV1.ST.Str.phsA	Start (59DT-1 Picked up) Phase A
DT59PTOV1.ST.Str.phsB	Start (59DT-1 Picked up) Phase B
DT59PTOV1.ST.Str.phsC	Start (59DT-1 Picked up) Phase C
DT59PTOV1.ST.Op.general	Operate (59DT-1 Operated)
DT59PTOV1.ST.Op.phsA	Operate (59DT-1 Operated) Phase A
DT59PTOV1.ST.Op.phsB	Operate (59DT-1 Operated) Phase B
DT59PTOV1.ST.Op.phsC	Operate (59DT-1 Operated) Phase C

DT59PTOV2

This section defines the logical node data of DT59PTOV2

Data Name	Description
DT59PTOV2.ST.Str.general	Start (59DT-2 Picked up)
DT59PTOV2.ST.Str.dirGeneral	Direction General
DT59PTOV2.ST.Str.phsA	Start (59DT-2 Picked up) Phase A
DT59PTOV2.ST.Str.phsB	Start (59DT-2 Picked up) Phase B
DT59PTOV2.ST.Str.phsC	Start (59DT-2 Picked up) Phase C
DT59PTOV2.ST.Op.general	Operate (59DT-2 Operated)
DT59PTOV2.ST.Op.phsA	Operate (59DT-2 Operated) Phase A
DT59PTOV2.ST.Op.phsB	Operate (59DT-2 Operated) Phase B
DT59PTOV2.ST.Op.phsC	Operate (59DT-2 Operated) Phase C

DT59PTOV3

This section defines the logical node data of DT59PTOV3

Data Name	Description
DT59PTOV3.ST.Str.general	Start (59DT-3 Picked up)
DT59PTOV3.ST.Str.dirGeneral	Direction General
DT59PTOV3.ST.Str.phsA	Start (59DT-3 Picked up) Phase A
DT59PTOV3.ST.Str.phsB	Start (59DT-3 Picked up) Phase B
DT59PTOV3.ST.Str.phsC	Start (59DT-3 Picked up) Phase C
DT59PTOV3.ST.Op.general	Operate (59DT-3 Operated)
DT59PTOV3.ST.Op.phsA	Operate (59DT-3 Operated) Phase A
DT59PTOV3.ST.Op.phsB	Operate (59DT-3 Operated) Phase B
DT59PTOV3.ST.Op.phsC	Operate (59DT-3 Operated) Phase C

DT59PTOV4

This section defines the logical node data of DT59PTOV4

Data Name	Description
DT59PTOV4.ST.Str.general	Start (59DT-4 Picked up)
DT59PTOV4.ST.Str.dirGeneral	Direction General
DT59PTOV4.ST.Str.phsA	Start (59DT-4 Picked up) Phase A
DT59PTOV4.ST.Str.phsB	Start (59DT-4 Picked up) Phase B
DT59PTOV4.ST.Str.phsC	Start (59DT-4 Picked up) Phase C
DT59PTOV4.ST.Op.general	Operate (59DT-4 Operated)
DT59PTOV4.ST.Op.phsA	Operate (59DT-4 Operated) Phase A
DT59PTOV4.ST.Op.phsB	Operate (59DT-4 Operated) Phase B
DT59PTOV4.ST.Op.phsC	Operate (59DT-4 Operated) Phase C

DT59PTOV5

This section defines the logical node data of DT59PTOV5

Data Name	Description
DT59PTOV5.ST.Str.general	Start (59DT-5 Picked up)
DT59PTOV5.ST.Str.dirGeneral	Direction General
DT59PTOV5.ST.Str.phsA	Start (59DT-5 Picked up) Phase A
DT59PTOV5.ST.Str.phsB	Start (59DT-5 Picked up) Phase B
DT59PTOV5.ST.Str.phsC	Start (59DT-5 Picked up) Phase C
DT59PTOV5.ST.Op.general	Operate (59DT-5 Operated)
DT59PTOV5.ST.Op.phsA	Operate (59DT-5 Operated) Phase A
DT59PTOV5.ST.Op.phsB	Operate (59DT-5 Operated) Phase B
DT59PTOV5.ST.Op.phsC	Operate (59DT-5 Operated) Phase C

DT59PTOV6

This section defines the logical node data of DT59PTOV6

Data Name	Description
DT59PTOV6.ST.Str.general	Start (59DT-6 Picked up)
DT59PTOV6.ST.Str.dirGeneral	Direction General
DT59PTOV6.ST.Str.phsA	Start (59DT-6 Picked up) Phase A
DT59PTOV6.ST.Str.phsB	Start (59DT-6 Picked up) Phase B
DT59PTOV6.ST.Str.phsC	Start (59DT-6 Picked up) Phase C
DT59PTOV6.ST.Op.general	Operate (59DT-6 Operated)
DT59PTOV6.ST.Op.phsA	Operate (59DT-6 Operated) Phase A
DT59PTOV6.ST.Op.phsB	Operate (59DT-6 Operated) Phase B
DT59PTOV6.ST.Op.phsC	Operate (59DT-6 Operated) Phase C

IT59PTOV1This section defines the logical node data of IT59PTOV1

Data Name	Description
IT59PTOV1.ST.Str.general	Start (59IT-1 Picked up)
IT59PTOV1.ST.Str.dirGeneral	Direction General
IT59PTOV1.ST.Str.phsA	Start (59IT-1 Picked up) Phase A
IT59PTOV1.ST.Str.phsB	Start (59IT-1 Picked up) Phase B
IT59PTOV1.ST.Str.phsC	Start (59IT-1 Picked up) Phase C
IT59PTOV1.ST.Op.general	Operate (59IT-1 Operated)
IT59PTOV1.ST.Op.phsA	Operate (59IT-1 Operated) Phase A
IT59PTOV1.ST.Op.phsB	Operate (59IT-1 Operated) Phase B
IT59PTOV1.ST.Op.phsC	Operate (59IT-1 Operated) Phase C

IT59PTOV2This section defines the logical node data of IT59PTOV2

Data Name	Description
IT59PTOV2.ST.Str.general	Start (59IT-2 Picked up)
IT59PTOV2.ST.Str.dirGeneral	Direction General
IT59PTOV2.ST.Str.phsA	Start (59IT-2 Picked up) Phase A
IT59PTOV2.ST.Str.phsB	Start (59IT-2 Picked up) Phase B
IT59PTOV2.ST.Str.phsC	Start (59IT-2 Picked up) Phase C
IT59PTOV2.ST.Op.general	Operate (59IT-2 Operated)
IT59PTOV2.ST.Op.phsA	Operate (59IT-2 Operated) Phase A
IT59PTOV2.ST.Op.phsB	Operate (59IT-2 Operated) Phase B
IT59PTOV2.ST.Op.phsC	Operate (59IT-2 Operated) Phase C

D50PIOC1This section defines the logical node data of D50PIOC1

Data Name	Description
D50PIOC1.ST.Str.general	Start (50-1 Picked up)
D50PIOC1.ST.Str.dirGeneral	Direction General
D50PIOC1.ST.Str.phsA	Start (50-1 Picked up) Phase A
D50PIOC1.ST.Str.dirPhsA	Direction Phase A
D50PIOC1.ST.Str.phsB	Start (50-1 Picked up) Phase B
D50PIOC1.ST.Str.dirPhsB	Direction Phase B
D50PIOC1.ST.Str.phsC	Start (50-1 Picked up) Phase C
D50PIOC1.ST.Str.dirPhsC	Direction Phase C
D50PIOC1.ST.Op.general	Operate (50-1 Operated)
D50PIOC1.ST.Op.phsA	Operate (50-1 Operated) Phase A
D50PIOC1.ST.Op.phsB	Operate (50-1 Operated) Phase B
D50PIOC1.ST.Op.phsC	Operate (50-1 Operated) Phase C

D50PIOC2

This section defines the logical node data of D50PIOC2

Data Name	Description
D50PIOC2.ST.Str.general	Start (50-2 Picked up)
D50PIOC2.ST.Str.dirGeneral	Direction General
D50PIOC2.ST.Str.phsA	Start (50-2 Picked up) Phase A
D50PIOC2.ST.Str.dirPhsA	Direction Phase A
D50PIOC2.ST.Str.phsB	Start (50-2 Picked up) Phase B
D50PIOC2.ST.Str.dirPhsB	Direction Phase B
D50PIOC2.ST.Str.phsC	Start (50-2 Picked up) Phase C
D50PIOC2.ST.Str.dirPhsC	Direction Phase C
D50PIOC2.ST.Op.general	Operate (50-2 Operated)
D50PIOC2.ST.Op.phsA	Operate (50-2 Operated) Phase A
D50PIOC2.ST.Op.phsB	Operate (50-2 Operated) Phase B
D50PIOC2.ST.Op.phsC	Operate (50-2 Operated) Phase C

D50NPIOC1

This section defines the logical node data of D50NPIOC1

Data Name	Description
D50NPIOC1.ST.Str.general	Start (50N-1 Picked up)
D50NPIOC1.ST.Str.dirGeneral	Direction General
D50NPIOC1.ST.Op.general	Operate (50N-1 Operated)

D50NPIOC2

This section defines the logical node data of D50NPIOC2

Data Name	Description
D50NPIOC2.ST.Str.general	Start (50N-2 Picked up)
D50NPIOC2.ST.Str.dirGeneral	Direction General
D50NPIOC2.ST.Op.general	Operate (50N-2 Operated)

D4650PIOC1

This section defines the logical node data of D4650PIOC1

Data Name	Description
D4650PIOC1.ST.Str.general	Start (46-50 Picked up)
D4650PIOC1.ST.Op.general	Operate (46-50 Operated)

D51PTOC1This section defines the logical node data of D51PTOC1

Data Name	Description
D51PTOC1.ST.Str.general	Start (51-1 Picked up)
D51PTOC1.ST.Str.dirGeneral	Direction General
D51PTOC1.ST.Str.phsA	Start (51-1 Picked up) Phase A
D51PTOC1.ST.Str.dirPhsA	Direction Phase A
D51PTOC1.ST.Str.phsB	Start (51-1 Picked up) Phase B
D51PTOC1.ST.Str.dirPhsB	Direction Phase B
D51PTOC1.ST.Str.phsC	Start (51-1 Picked up) Phase C
D51PTOC1.ST.Str.dirPhsC	Direction Phase C
D51PTOC1.ST.Op.general	Operate (51-1 Operated)
D51PTOC1.ST.Op.phsA	Operate (51-1 Operated) Phase A
D51PTOC1.ST.Op.phsB	Operate (51-1 Operated) Phase B
D51PTOC1.ST.Op.phsC	Operate (51-1 Operated) Phase C

D51PTOC2This section defines the logical node data of D51PTOC2

Data Name	Description
D51PTOC2.ST.Str.general	Start (51-2 Picked up)
D51PTOC2.ST.Str.dirGeneral	Direction General
D51PTOC2.ST.Str.phsA	Start (51-2 Picked up) Phase A
D51PTOC2.ST.Str.dirPhsA	Direction Phase A
D51PTOC2.ST.Str.phsB	Start (51-2 Picked up) Phase B
D51PTOC2.ST.Str.dirPhsB	Direction Phase B
D51PTOC2.ST.Str.phsC	Start (51-2 Picked up) Phase C
D51PTOC2.ST.Str.dirPhsC	Direction Phase C
D51PTOC2.ST.Op.general	Operate (51-2 Operated)
D51PTOC2.ST.Op.phsA	Operate (51-2 Operated) Phase A
D51PTOC2.ST.Op.phsB	Operate (51-2 Operated) Phase B
D51PTOC2.ST.Op.phsC	Operate (51-2 Operated) Phase C

D51NPTOC1This section defines the logical node data of D51NPTOC1

Data Name	Description
D51NPTOC1.ST.Str.general	Start (51N-1 Picked up)
D51NPTOC1.ST.Str.dirGeneral	Direction General
D51NPTOC1.ST.Op.general	Operate (51N-1 Operated)

D51NPTOC2This section defines the logical node data of D51NPTOC2

Data Name	Description
D51NPTOC2.ST.Str.general	Start (51N-2 Picked up)
D51NPTOC2.ST.Str.dirGeneral	Direction General
D51NPTOC2.ST.Op.general	Operate (51N-2 Operated)

D4651PTOC1This section defines the logical node data of D4651PTOC1

Data Name	Description
D4651PTOC1.ST.Str.general	Start (46-51 Picked up)
D4651PTOC1.ST.Op.general	Operate (46-51 Operated)

D49PTTR1This section defines the logical node data of D49PTTR1

Data Name	Description
D49PTTR1.MX.Tmp.mag.f	% 49 (% Thermal OL)
D49PTTR1.ST.Str.general	Start (49 Picked up)
D49PTTR1.ST.Str.phsA	Start (49 Picked up) Phase A
D49PTTR1.ST.Str.phsB	Start (49 Picked up) Phase B
D49PTTR1.ST.Str.phsC	Start (49 Picked up) Phase C
D49PTTR1.ST.AlmThm.general	Alarm (49 AL Operated)
D49PTTR1.ST.Op.general	Operate (49 Operated)

D81H2PHAR1This section defines the logical node data of D81H2PHAR1

Data Name	Description
D81H2PHAR1.ST.Str.general	Operate (81HBL2 Operated)

D50BFRBRF1This section defines the logical node data of D50BFRBRF1

Data Name	Description
D50BFRBRF1.ST.OpIn.general	Operate (50BF D1 Operated)
D50BFRBRF1.ST.OpIn.phsA	Operate (50BF D1 Phase A Operated)
D50BFRBRF1.ST.OpIn.phsB	Operate (50BF D1 Phase B Operated)
D50BFRBRF1.ST.OpIn.phsC	Operate (50BF D1 Phase C Operated)
D50BFRBRF1.ST.OpEx.general	Operate (50BF D2 Operated)
D50BFRBRF1.ST.OpEx.phsA	Operate (50BF D2 Phase A Operated)
D50BFRBRF1.ST.OpEx.phsB	Operate (50BF D2 Phase B Operated)
D50BFRBRF1.ST.OpEx.phsC	Operate (50BF D2 Phase C Operated)

D79RREC1

This section defines the logical node data of D79RREC1

Data Name	Description
D79RREC1.ST.BlkRec.stVal	79 Block Status
D79RREC1.ST.Auto.stVal	External Switch Status (79 IN function output)
D79RREC1.ST.Op.general	AR Operation (79 Operated)
D79RREC1.ST.AutoRecSt.stVal	AR Multiple Operation

D46BCRBCD1

This section defines the logical node data of D46BCRBCD1

Data Name	Description
D46BCRBCD1.ST.Op.general	Operate (46BC Operated)

D74TCSRTCS1

This section defines the logical node data of D74TCSRTCS1

Data Name	Description
D74TCSRTCS1.ST.Op1.general	Operate (74TCS-1 Operated)
D74TCSRTCS1.ST.Op2.general	Operate (74TCS-2 Operated)

D60RVTS1

This section defines the logical node data of D60RVTS1

Data Name	Description
D60RVTS1.ST.Op.general	Operate (60VTS Operated)

D60RCTS1

This section defines the logical node data of D60RCTS1

Data Name	Description
D60RCTS1.ST.Op.general	Operate (60CTS Operated)

I2TRCBC1

This section defines the logical node data of I2TRCBC1

Data Name	Description
I2TRCBC1.MX.I2TAcc.mag.f	I2T Accumulated
I2TRCBC1.MX.I2TLstOp.mag.f	I2T Value – (Last Operation)
I2TRCBC1.ST.Op.general	Operate (I2T Operated)

TRCALH1

This section defines the logical node data of TRCALH1

Data Name	Description
TRCALH1.ST.GrWrn.stVal	Function(s) Starter Picked up
TRCALH1.ST.GrAlm.stVal	Function(s) Trip Operated

ANAMMXU1This section defines the logical node data of ANAMMXU1

Data Name	Description
ANAMMXU1.MX.PhV.phsA.cVal.mag.f	VA – Magnitude
ANAMMXU1.MX.PhV.phsA.cVal.ang.f	VA – Angle
ANAMMXU1.MX.PhV.phsB.cVal.mag.f	VB – Magnitude
ANAMMXU1.MX.PhV.phsB.cVal.ang.f	VB – Angle
ANAMMXU1.MX.PhV.phsC.cVal.mag.f	VC – Magnitude
ANAMMXU1.MX.PhV.phsC.cVal.ang.f	VC – Angle
ANAMMXU1.MX.PhV.neut.cVal.mag.f	VN – Magnitude
ANAMMXU1.MX.PhV.neut.cVal.ang.f	VN – Angle
ANAMMXU1.MX.A.phsA.cVal.mag.f	IA – Magnitude
ANAMMXU1.MX.A.phsA.cVal.ang.f	IA – Angle
ANAMMXU1.MX.A.phsB.cVal.mag.f	IB – Magnitude
ANAMMXU1.MX.A.phsB.cVal.ang.f	IB – Angle
ANAMMXU1.MX.A.phsC.cVal.mag.f	IC – Magnitude
ANAMMXU1.MX.A.phsC.cVal.ang.f	IC – Angle
ANAMMXU1.MX.A.neut.cVal.mag.f	IN – Magnitude
ANAMMXU1.MX.A.neut.cVal.ang.f	IN – Angle
ANAMMXU1.MX.TotW.mag.f	Real Power
ANAMMXU1.MX.TotVar.mag.f	Reactive Power
ANAMMXU1.MX.TotPF.mag.f	Power Factor
ANAMMXU1.MX.Hz.mag.f	Frequency

SEQMSQI1This section defines the logical node data of SEQMSQI1

Data Name	Description
SEQMSQI1.MX.SeqV.c1.cVal.mag.f	V1 – Pos. Seq. Magnitude
SEQMSQI1.MX.SeqV.c2.cVal.mag.f	V2 – Neg. Seq. Magnitude
SEQMSQI1.MX.SeqV.c3.cVal.mag.f	V0 – Zero Seq. Magnitude
SEQMSQI1.MX.SeqA.c1.cVal.mag.f	I1 – Pos. Seq. Magnitude
SEQMSQI1.MX.SeqA.c2.cVal.mag.f	I2 – Neg. Seq. Magnitude
SEQMSQI1.MX.SeqA.c3.cVal.mag.f	I0 – Zero Seq. Magnitude

DRRDRE1

This section defines the logical node data of DRRDRE1

Data Name	Description
DRRDRE1.ST.RcdStr.stVal	Disturbance Recording Started
DRRDRE1.ST.RcdMade.stVal	Disturbance Recording Made
DRRDRE1.ST.FltNum.stVal	Fault Number
DRRDRE1.ST.MemUsed.stVal	% Memory Used to store DR

LLNO

This section defines the logical node data of LLNO

Data Name	Description
LLNO.SP.SGCB.NumofSG	Total no: of Setting Groups
LLNO.SP.SGCB.ActSG	Active Setting Group
LLNO.SP.SGCB.EditSG	Edit Setting Group
LLNO.SP.SGCB.CnfEdit	Confirm Edit Setting Group
LLNO.SP.SGCB.LActTm	Last Time Edited (Time Stamp)

EIGGIO1

This section defines the logical node data of EIGGIO1

Data Name	Description
EIGGIO1.ST.Ind1.stVal	External Input - 1
EIGGIO1.ST.Ind2.stVal	External Input - 2
EIGGIO1.ST.Ind3.stVal	External Input - 3
EIGGIO1.ST.Ind4.stVal	External Input - 4

OCGGIO1

This section defines the logical node data of OCGGIO1

Data Name	Description
OCGGIO1.ST.Ind1.stVal	Output Contact - 1
OCGGIO1.ST.Ind2.stVal	Output Contact - 2
OCGGIO1.ST.Ind3.stVal	Output Contact - 3
OCGGIO1.ST.Ind4.stVal	Output Contact - 4
OCGGIO1.ST.Ind5.stVal	Output Contact - 5
OCGGIO1.ST.Ind6.stVal	Output Contact - 6
OCGGIO1.ST.Ind7.stVal	Output Contact - 7
OCGGIO1.ST.Ind8.stVal	Output Contact - 8

PLGGIO1This section defines the logical node data of PLGGIO1

Data Name	Description
PLGGIO1.ST.Ind1.stVal	Prologic - 1
PLGGIO1.ST.Ind2.stVal	Prologic – 2
PLGGIO1.ST.Ind3.stVal	Prologic – 3
PLGGIO1.ST.Ind4.stVal	Prologic – 4
PLGGIO1.ST.Ind5.stVal	Prologic – 5
PLGGIO1.ST.Ind6.stVal	Prologic – 6
PLGGIO1.ST.Ind7.stVal	Prologic – 7
PLGGIO1.ST.Ind8.stVal	Prologic – 8
PLGGIO1.ST.Ind9.stVal	Prologic – 9
PLGGIO1.ST.Ind10.stVal	Prologic – 10
PLGGIO1.ST.Ind11.stVal	Prologic – 11
PLGGIO1.ST.Ind12.stVal	Prologic – 12
PLGGIO1.ST.Ind13.stVal	Prologic – 13
PLGGIO1.ST.Ind14.stVal	Prologic – 14
PLGGIO1.ST.Ind15.stVal	Prologic – 15
PLGGIO1.ST.Ind16.stVal	Prologic – 16
PLGGIO1.ST.Ind17.stVal	Prologic – 17
PLGGIO1.ST.Ind18.stVal	Prologic – 18
PLGGIO1.ST.Ind19.stVal	Prologic – 19
PLGGIO1.ST.Ind20.stVal	Prologic – 20

LEDGGIO1This section defines the logical node data of LEDGGIO1

Data Name	Description
LEDGGIO1.ST.Ind1.stVal	LED Status- 1
LEDGGIO1.ST.Ind2.stVal	LED Status- 2
LEDGGIO1.ST.Ind3.stVal	LED Status- 3
LEDGGIO1.ST.Ind4.stVal	LED Status- 4
LEDGGIO1.ST.Ind5.stVal	LED Status- 5
LEDGGIO1.ST.Ind6.stVal	LED Status- 6
LEDGGIO1.ST.Ind7.stVal	LED Status- 7
LEDGGIO1.ST.Ind8.stVal	LED Status- 8

HEALTHGGIO1This section defines the logical node data of HEALTHGGIO1

Data Name	Description
HEALTHGGIO1.ST.Ind1.stVal	Relay Healthy Status Info.
HEALTHGGIO1.ST.Ind2.stVal	IRIG-B Functional Status Info.
HEALTHGGIO1.ST.Ind3.stVal	SNTP Functional Status Info.

VIGGIO1This section defines the logical node data of VIGGIO1

Data Name	Description
VIGGIO1.ST.Ind1.stVal	Virtual Input – 1
VIGGIO1.ST.Ind2.stVal	Virtual Input – 2
VIGGIO1.ST.Ind3.stVal	Virtual Input – 3
VIGGIO1.ST.Ind4.stVal	Virtual Input – 4
VIGGIO1.ST.Ind5.stVal	Virtual Input – 5
VIGGIO1.ST.Ind6.stVal	Virtual Input – 6
VIGGIO1.ST.Ind7.stVal	Virtual Input – 7
VIGGIO1.ST.Ind8.stVal	Virtual Input – 8
VIGGIO1.ST.Ind9.stVal	Virtual Input – 9
VIGGIO1.ST.Ind10.stVal	Virtual Input – 10
VIGGIO1.ST.Ind11.stVal	Virtual Input – 11
VIGGIO1.ST.Ind12.stVal	Virtual Input – 12
VIGGIO1.ST.Ind13.stVal	Virtual Input – 13
VIGGIO1.ST.Ind14.stVal	Virtual Input – 14
VIGGIO1.ST.Ind15.stVal	Virtual Input – 15
VIGGIO1.ST.Ind16.stVal	Virtual Input – 16
VIGGIO1.ST.Ind17.stVal	Virtual Input – 17
VIGGIO1.ST.Ind18.stVal	Virtual Input – 18
VIGGIO1.ST.Ind19.stVal	Virtual Input – 19
VIGGIO1.ST.Ind20.stVal	Virtual Input – 20
VIGGIO1.ST.Ind21.stVal	Virtual Input – 21
VIGGIO1.ST.Ind22.stVal	Virtual Input – 22
VIGGIO1.ST.Ind23.stVal	Virtual Input – 23
VIGGIO1.ST.Ind24.stVal	Virtual Input – 24
VIGGIO1.ST.Ind25.stVal	Virtual Input – 25
VIGGIO1.ST.Ind26.stVal	Virtual Input – 26
VIGGIO1.ST.Ind27.stVal	Virtual Input – 27
VIGGIO1.ST.Ind28.stVal	Virtual Input – 28
VIGGIO1.ST.Ind29.stVal	Virtual Input – 29
VIGGIO1.ST.Ind30.stVal	Virtual Input – 30

VIGGIO2This section defines the logical node data of VIGGIO2

Data Name	Description
VIGGIO2.ST.Ind1.stVal	Virtual Input Control– 1
VIGGIO2.ST.Ind2.stVal	Virtual Input Control– 2
VIGGIO2.ST.Ind3.stVal	Virtual Input Control– 3
VIGGIO2.ST.Ind4.stVal	Virtual Input Control– 4
VIGGIO2.ST.Ind5.stVal	Virtual Input Control– 5
VIGGIO2.ST.Ind6.stVal	Virtual Input Control– 6
VIGGIO2.ST.Ind7.stVal	Virtual Input Control– 7
VIGGIO2.ST.Ind8.stVal	Virtual Input Control– 8
VIGGIO2.ST.Ind9.stVal	Virtual Input Control– 9
VIGGIO2.ST.Ind10.stVal	Virtual Input Control– 10
VIGGIO2.ST.Ind11.stVal	Virtual Input Control– 11
VIGGIO2.ST.Ind12.stVal	Virtual Input Control– 12
VIGGIO2.ST.Ind13.stVal	Virtual Input Control– 13
VIGGIO2.ST.Ind14.stVal	Virtual Input Control– 14
VIGGIO2.ST.Ind15.stVal	Virtual Input Control– 15
VIGGIO2.ST.Ind16.stVal	Virtual Input Control– 16
VIGGIO2.ST.Ind17.stVal	Virtual Input Control– 17
VIGGIO2.ST.Ind18.stVal	Virtual Input Control– 18
VIGGIO2.ST.Ind19.stVal	Virtual Input Control– 19
VIGGIO2.ST.Ind20.stVal	Virtual Input Control– 20
VIGGIO2.ST.Ind21.stVal	Virtual Input Control– 21
VIGGIO2.ST.Ind22.stVal	Virtual Input Control– 22
VIGGIO2.ST.Ind23.stVal	Virtual Input Control– 23
VIGGIO2.ST.Ind24.stVal	Virtual Input Control– 24
VIGGIO2.ST.Ind25.stVal	Virtual Input Control– 25
VIGGIO2.ST.Ind26.stVal	Virtual Input Control– 26
VIGGIO2.ST.Ind27.stVal	Virtual Input Control– 27
VIGGIO2.ST.Ind28.stVal	Virtual Input Control– 28
VIGGIO2.ST.Ind29.stVal	Virtual Input Control– 29
VIGGIO2.ST.Ind30.stVal	Virtual Input Control– 30

VIGGIO3This section defines the logical node data of VIGGIO3

Data Name	Description
VIGGIO3.ST.Ind1.stVal	Virtual Output Control– 1
VIGGIO3.ST.Ind2.stVal	Virtual Output Control– 2
VIGGIO3.ST.Ind3.stVal	Virtual Output Control– 3

Data Name	Description
VIGGIO3.ST.Ind4.stVal	Virtual Output Control– 4
VIGGIO3.ST.Ind5.stVal	Virtual Output Control– 5
VIGGIO3.ST.Ind6.stVal	Virtual Output Control– 6
VIGGIO3.ST.Ind7.stVal	Virtual Output Control– 7
VIGGIO3.ST.Ind8.stVal	Virtual Output Control– 8
VIGGIO3.ST.Ind9.stVal	Virtual Output Control– 9
VIGGIO3.ST.Ind10.stVal	Virtual Output Control– 10
VIGGIO3.ST.Ind11.stVal	Virtual Output Control– 11
VIGGIO3.ST.Ind12.stVal	Virtual Output Control– 12
VIGGIO3.ST.Ind13.stVal	Virtual Output Control– 13
VIGGIO3.ST.Ind14.stVal	Virtual Output Control– 14
VIGGIO3.ST.Ind15.stVal	Virtual Output Control– 15
VIGGIO3.ST.Ind16.stVal	Virtual Output Control– 16
VIGGIO3.ST.Ind17.stVal	Virtual Output Control– 17
VIGGIO3.ST.Ind18.stVal	Virtual Output Control– 18
VIGGIO3.ST.Ind19.stVal	Virtual Output Control– 19
VIGGIO3.ST.Ind20.stVal	Virtual Output Control– 20
VIGGIO3.ST.Ind21.stVal	Virtual Output Control– 21
VIGGIO3.ST.Ind22.stVal	Virtual Output Control– 22
VIGGIO3.ST.Ind23.stVal	Virtual Output Control– 23
VIGGIO3.ST.Ind24.stVal	Virtual Output Control– 24
VIGGIO3.ST.Ind25.stVal	Virtual Output Control– 25
VIGGIO3.ST.Ind26.stVal	Virtual Output Control– 26
VIGGIO3.ST.Ind27.stVal	Virtual Output Control– 27
VIGGIO3.ST.Ind28.stVal	Virtual Output Control– 28
VIGGIO3.ST.Ind29.stVal	Virtual Output Control– 29
VIGGIO3.ST.Ind30.stVal	Virtual Output Control– 30

Fault Data Logical Nodes

This section defines the logical node data under FAULT DATA. All the protection functions are grouped as 3 Logical Nodes below.

Data Name	Description
FLTDATA1.MX.A	Fault Currents (IA, IB, IC, IN)
FLTDATA1.MX.PhV	Fault Currents (VA, VB, VC, VN)
FLTDATA1.MX.SeqA	Fault Current (I2, I2/I1)

FLTDATA1This section defines the logical node data of FLTDATA1

Data Name	Description
FLTDATA1.MX.A.phsA.cVal.mag.f	IA - Magnitude
FLTDATA1.MX.A.phsA.cVal.ang.f	IA - Angle
FLTDATA1.MX.A.phsB.cVal.mag.f	IB - Magnitude
FLTDATA1.MX.A.phsB.cVal.ang.f	IB - Angle
FLTDATA1.MX.A.phsC.cVal.mag.f	IC - Magnitude
FLTDATA1.MX.A.phsC.cVal.ang.f	IC - Angle
FLTDATA1.MX.A.neut.cVal.mag.f	IN – Magnitude
FLTDATA1.MX.A.neut.cVal.ang.f	IN – Angle
FLTDATA1.MX.PhV.phsA.cVal.mag.f	VA - Magnitude
FLTDATA1.MX.PhV.phsA.cVal.ang.f	VA - Angle
FLTDATA1.MX.PhV.phsB.cVal.mag.f	VB - Magnitude
FLTDATA1.MX.PhV.phsB.cVal.ang.f	VB - Angle
FLTDATA1.MX.PhV.phsC.cVal.mag.f	VC - Magnitude
FLTDATA1.MX.PhV.phsC.cVal.ang.f	VC - Angle
FLTDATA1.MX.PhV.neut.cVal.mag.f	VN – Magnitude
FLTDATA1.MX.PhV.neut.cVal.ang.f	VN – Angle
FLTDATA1.MX.SeqA.c2.cVal.mag.f	I2 – Neg. Seq. Magnitude (46/50, 46/51)
FLTDATA1.MX.SeqA.c2.cVal.ang.f	I2 – Neg. Seq. Angle (46/50, 46/51)
FLTDATA1.MX.SeqA.c1.cVal.mag.f	Ratio 46BC (I2/I1)