



WHITE FIRE

AN OUTDOOR WORK OF ART

Fire fascinates us. Since ancient times, it has been something magical and inspirational that brings us together. The dancing flames hypnotise and connect. Few things feel as cosy as sitting together around a flickering fire. Enjoying the intense warmth, sharing stories and preparing food together.

Light a fire and people will join to sit around it. White Fire brings that magic to your garden.

**TURN EVERY MOMENT
INTO AN EXPERIENCE.**

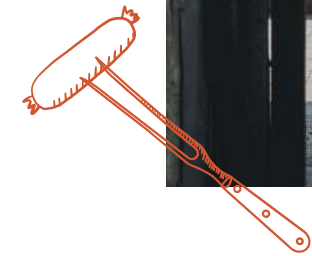

SATURDAYS

WHITE FIRE about p. 4



ARE FOR

COOK LIKE
A PRO
products p. 12



ADVENTURE,

SUNDAYS



GRILLING
ISN'T A HOBBY,
IT'S A PASSION

accessories p. 14

ARE FOR



GOOD FOOD.



OUR MOUTH WATERING
BURGER & FISH

recipes p. 24





**ABOUT
WHITE FIRE**

MAKE MOMENTS THAT MATTER

Transform your garden into a cosy meeting place and invite friends over for a fiery experience. White Fire is all about intense outdoor fire experiences, designed and manufactured in Europe. From a low-smoke brasero to a versatile outdoor kitchen that lets you enjoy flames, throw fantastic BBQ parties and bring people together.

White Fire resolutely strives for locally designed and developed quality products. Made from the best materials, we guarantee many years of enjoyment. Laser-cut thick corten steel, FSC-approved wood, or supple Italian leather: we keep looking for the perfect and eco-responsible material that meets our high-quality requirements.

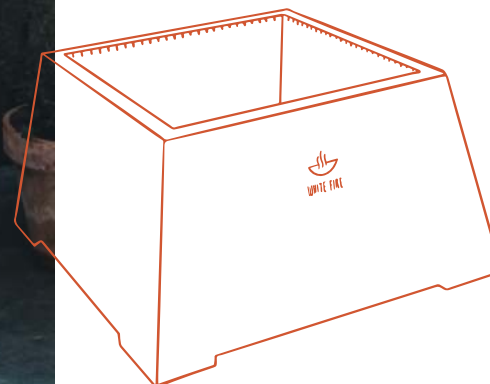

**OUR MISSION?
TO BRING PEOPLE TOGETHER
FOR MOMENTS THAT MATTER.**



AWAKEN YOUR INNER GRILL MASTER

Grilling outdoors is not just a way to cook food, it's an experience. From the sizzling sounds to the mouth-watering aroma of smoke and spices, grilling activates our senses. Whether it's a summer barbecue or a winter cookout, grilling outdoors is an all-season opportunity to awaken your inner grill master.

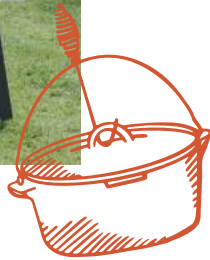

There's something special about the process of grilling. From the preparation of the food to the perfect placement on the grill, there's a sense of pride and accomplishment that comes from cooking a delicious meal for your family and friends. The process of grilling allows you to slow down and enjoy the moment.

So whether you're a seasoned grill master or a first-time griller, fire up the White Fire, call some friends and family, and enjoy.



COOKING OVER AN OPEN FLAME IS LIKE MAGIC, IT TURNS FOOD INTO MEMORIES.

**NOTHING
BRINGS PEOPLE
TOGETHER LIKE
A BACKYARD
BARBECUE.**

**DESIGNED AND MADE
IN EUROPE**



BARBECUE LID

page 16

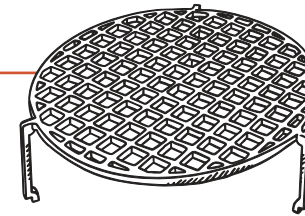

BARBECUE GRILL

page 16



FOOD BUMPER

page 16

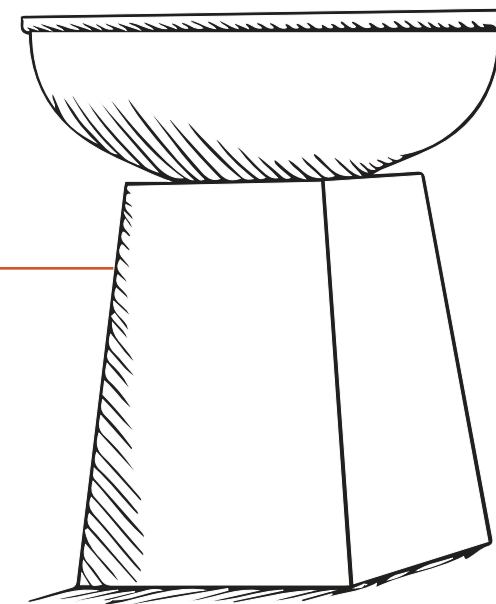

BARBECUE

page 12

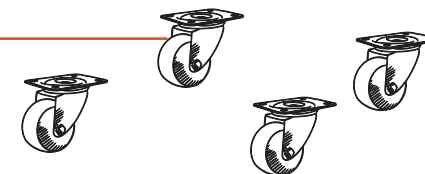

SET OF 4 WHEELS

page 17

A STATEMENT FOR EVERY BACKYARD



QUALITY & COLOUR

CORTEN STEEL

White Fire products are made from laser-cut corten steel, a type of steel alloy that is highly resistant to corrosion and weathering. When exposed to the elements, corten steel forms a protective layer that adds a beautiful patina to the material that shields it from further corrosion, making it an excellent choice for outdoor use.

In addition to its natural weather resistance, corten steel is also highly durable and low-maintenance. It requires no painting or sealing, making it a cost-effective and eco-friendly material choice.



BLACK

Do you prefer black over corten steel? The black White Fires are finished with a heatproof black powder coating. Powder coating is a process that involves applying a dry powder to a metal surface and then heating it until it forms a protective layer.

This powder coating lends your grill a sleek elegant black look, and is easy to clean with just soap and water. Powder coating is environmentally friendly, as it does not involve any solvents or volatile organic compounds.



BARBECUE IN CORTEN STEEL OR BLACK

Experience the thrill of authentic outdoor grilling and cooking.

The White Fire outdoor kitchen is a versatile alternative to an ordinary barbecue. You can grill, fry, cook and smoke food on it while your guests are enjoying the cosiness of sitting around the fire.



The spacious plancha with a diameter of 99cm gives you space to prepare various dishes for groups of up to 16 people in one go. The plancha slopes slightly inwards so that the hot oil always remains at a safe distance. The White Fire fire bowl is wide and flat, allowing for different heat zones. On one side you can sear a steak and on the other, you can keep food warm. Your sauce can simmer in between the two.

Made of weathering steel, this multifunctional cooking island is solid. The White Fire barbecue is particularly stable thanks to its widening foot. Good to know when you're playing with fire. Even when you use the add-on wheels, the centre of gravity is well supported. The barbecue can be left outdoors if covered with a lid. The weather will only make its beautiful corten steel colour even more stunning.

Corten steel	3165113
Black	3165122

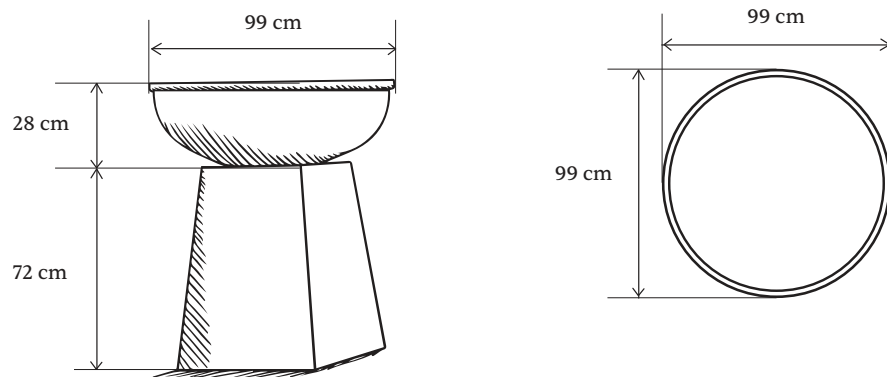

LOW-SMOKE BRASERO IN CORTEN STEEL OR BLACK

Love fire but not smoke? Avoid stinging eyes and clothes that smell of a campfire thanks to the White Fire brasero's efficient double combustion system. Minuscule particles that normally become smoke are burned up by the preheated oxygen blown in at the top. This makes the fire burn brightly and helps everyone around it stay comfortable.



Designed and produced in Belgium from thick, laser-cut weathering corten steel. The black version is finished with a heatproof black powder coating for a superior smooth look.

Easy to use, safe and smokeless for fun times in the garden.

Corten steel	3165118
Black	3165123

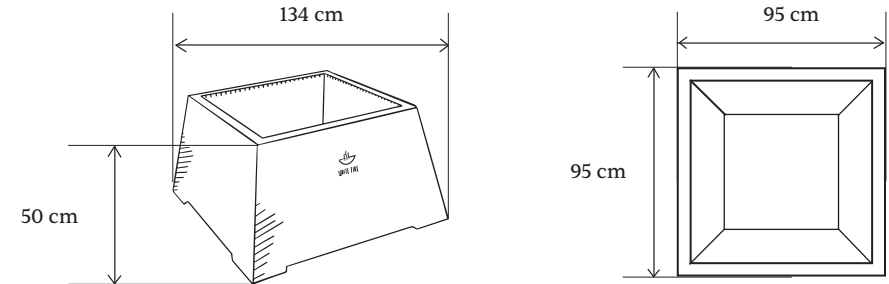



ACCESSORIES

ACCESSORIZE YOUR WHITE FIRE





BARBECUE LID

A White Fire barbecue that stays outside is best covered with a lid that keeps it well sealed. Made from the same weathering steel, this sturdy lid fits perfectly. The slight curve means rainwater will run off the barbecue, keeping the inside dry. And the large handle makes it easy to lift. Weatherproof and beautiful!

Corten steel	3165116
Black	coming soon



BARBECUE FOOD BUMPER

The White Fire food bumper prevents delicious food like cherry tomatoes, meatballs or sausages from rolling into the fire. The food bumper keeps them safely on the plancha. The three small feet mean that the ring is just high enough to allow you to push unwanted remains and scrapings into the fire. It can also be used with the White Fire barbecue grill.

Ø 52	3165121
------	---------



BARBECUE GRILL

Expand the possibilities of your White Fire barbecue even further with the multifunctional grill. It is perfect for grilling large cuts of meat or vegetables directly above the fire while you prepare other food on the large plancha. This sturdy grill is also ideal for heating a large pan or cooking in a frying pan over the flames. Or why not make coffee to accompany dessert? The height of the grill makes it easy to add wood to the fire.

Ø 48	3165115
------	---------



BARBECUE SET OF 4 WHEELS

With the optional set of four wheels, the White Fire barbecue will roll smoothly over hard, flat surfaces. That makes it easy to roll it from the garden to the garage, move it to a sunny spot or find the perfect set-up on your patio. This sturdy set of wheels is easy to attach to the bottom of the barbecue by screwing them to the mounting points. The set consists of two normal wheels and two castors for stable transport.

Set of 4	3165114
----------	---------



BRASERO SET OF 4 WHEELS

With the optional set of four wheels, the White Fire brasero will roll smoothly to the perfect spot. Find your ideal spot on the patio or move it inside for the winter. This sturdy set of wheels is easy to attach to the bottom of the brasero by screwing them to the mounting points. The set consists of 4 castors for easy transportation. It will roll best on hard, flat surfaces.

Set of 4	3165120
----------	---------



OIL DISPENSER

Oil is essential when you cook on your White Fire barbecue. So this stainless steel oil can is an indispensable tool when grilling. The wide base provides stability, and the top has a functional design. The leakproof spout with an airhole ensures you use the right amount of oil, and the funnel-shaped top makes the dispenser easy to fill.

500 ml	9601159
--------	---------



CUTTING BOARD

The White Fire cutting board is made of oiled, FSC approved European oak. Two concealed handles at the bottom and a juice groove all the way around the board allow you to cut and serve without spilling. It has rubber feet so it stands stably on your table or worktop.

45 x 35 cm	627013
------------	--------



CEDAR SMOKING BOARDS

The White Fire smoking boards made of Canadian cedarwood are a versatile addition for the ambitious chef. When placed on the grill or plancha, the wood starts to smoulder and the smoke will infuse your food with a delicious flavour. Used on the plancha, they form an additional buffer against the high heat. They keep the food nice and hot until it is served and add a subtle flavour.

30 x 15 cm - set of 2	7057011
-----------------------	---------

15 x 11 cm - set of 2	3345320
-----------------------	---------



LEATHER APRON

The White Fire leather apron made of high-quality, supple, Italian leather is a stylish way to protect yourself from stains and heat. The soft leather curves nicely around your body. The brass rivets complete the fashionable look of this apron which is hand-made in Belgium.

We've considered ease of use as well! For example, there's a brass hook on the left to hang your tongs; on the right, there's a strap to hang a towel from. Both the tie around your back and the one around your neck are adjustable for a perfect fit.

one size	2270601
----------	---------

**COMING SOON
ACCESSORIES**

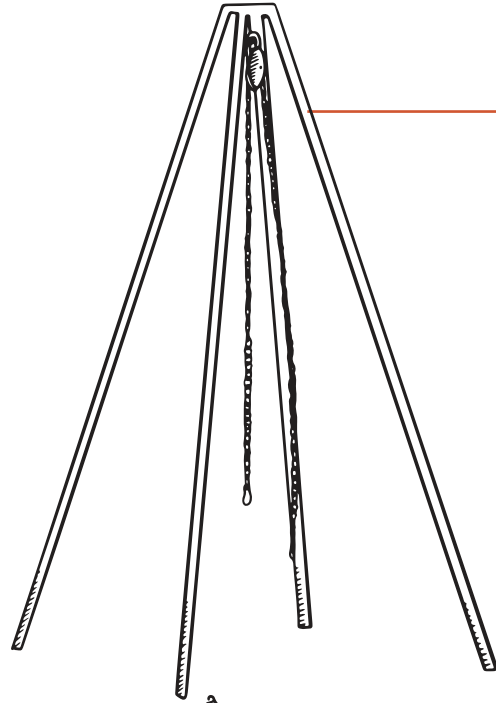

A-FRAME

coming soon

DUTCH OVEN

coming soon

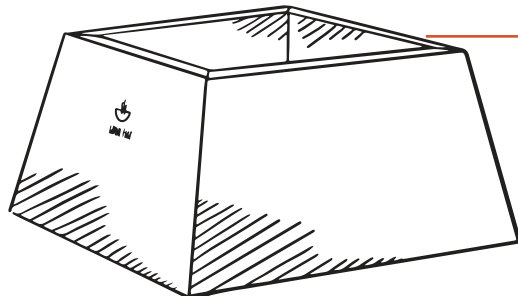
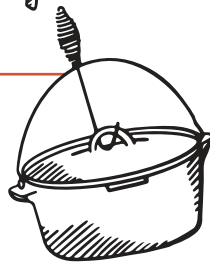

**LOW-SMOKE
BRASERO**

page 13

**TAKE YOUR
OUTDOOR
EXPERIENCE TO
THE NEXT LEVEL.**

WWW.WHITEFIRE.BE

COOKING OUTDOORS MAKES EVERY MEAL AN ADVENTURE.

TIPS & TRICKS



GRILLING

Grease the plancha with oil before lighting the barbecue, making sure that the plate is always oiled during and after baking. This way, the plancha will always remain “nourished”.

Choose sunflower, peanut or rice oil, these are more resistant to very high temperatures than olive oil, for example.

The best fuel to use are solid logs with a long burning time, such as beech or ash. With these types of wood you need less wood and you will get more heat and less smoke.



MAINTENANCE

Make sure your plancha is always coated with some oil.

To clean the plancha, all you need is a spatula. No need for a sanding sponge or other cleaning products!

The appliance itself is made of corten steel, which is perfectly resistant to weather and wind. Therefore, without the plancha, it can be left outside all year round.



FISH ON THE BARBECUE

PULLED SALMON SANDWICH

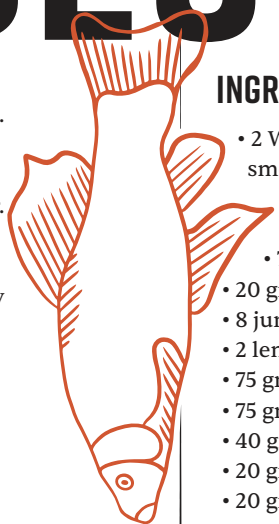

INGREDIENTS (4P)

- 1 Soak the smoking boards for 1 hour in water.
- 2 Crush the juniper berries and mix them with the salt and the sugar in a litre of water. Place the salmon fillets in the mixture and marinate in the fridge for one hour. Rinse the salmon fillets with cold water and gently pat them dry.
- 3 Finely chop the green herbs.
- 4 Arrange the salmon fillets on the smoking boards and top with half of the dill and the zest of 1 lemon. Place the smoking boards with the salmon on the White Fire plancha for 20 to 30 minutes until the salmon is nicely warm smoked.
- 5 Cut the rolls in half, rub with olive oil and grill lightly.
- 6 Cut the lemons in half and grill them with the flesh on the plate. Cut the mango into cubes and grill them a golden brown.
- 7 Mix the yoghurt and the mayonnaise with the remaining green herbs and season with pepper and salt.
- 8 Pull the warm smoked salmon. Top the roll with the herb mayonnaise, lettuce, salmon, mango, and finish with the cress and a few pieces of spring onion. Sprinkle with the roasted lemon and serve.

- 2 White Fire cedar smoking boards
- 300 grams salmon fillet with skin
- 70 grams of sea salt
- 20 grams of sugar
- 8 juniper berries
- 2 lemons
- 75 grams full yoghurt
- 75 grams of mayonnaise
- 40 grams of dill
- 20 grams of chives
- 20 grams of basil
- 20 grams of cress or shoots
- 1 solid mango
- 100 grams of mixed lettuce
- 1 stalk of spring onion
- 2 multigrain rolls



MEAT ON THE BARBECUE

SMASHED BEEF BURGER



- 1 Mix the mayonnaise, ketchup, Tabasco and Worcestershire sauce.
- 2 Finely chop the iceberg lettuce and mix into the sauce. Slice the gherkins.
- 3 Cut the buns in half, brush them with olive oil and grill them crispy on the plancha, set aside.
- 4 Season the minced meat with salt and pepper salt and roll into 8 equal-sized balls. Place the balls on the plancha and flatten them with the spatula to the size of the buns. While frying, brush them with mustard.
- 5 Fry the onion and bacon until crispy.
- 6 Place the slices of cheese on the burgers until they start to melt, and top with the fried onion.
- 7 Build up the burger with iceberg lettuce, 2 burgers with cheese and onion, gherkins, bacon and cress.

INGREDIENTS (4P)

- 1 large red onion
- 2 large gherkins
- 4 hamburger buns
- 600 grams of minced beef
- 8 slices of bacon
- 2 tablespoons mustard
- 4 slices cheddar cheese
- 1/4th head of iceberg lettuce
- 3 tbsp full-fat mayonnaise
- 1 tsp Tabasco
- 1 tsp Worcestershire sauce
- 1 tsp Pineau de Charentes (or whisky)
- Olive oil
- 20 g cress

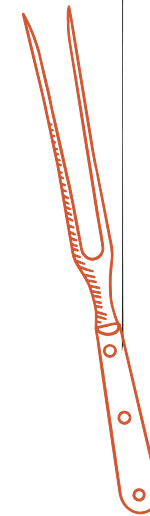



make memories

**EAT
WELL
TRAVEL
OFTEN**

**WHITE FIRE
BEVRIJDINGSLAAN 13-15
8700 TIELT**

**INFO@WHITEFIRE.BE
WWW.WHITEFIRE.BE
f @WHITEFIRE_BBQ**

**QUESTIONS OR
NEED MORE
INFO ON OUR
PRODUCTS? OUR
TEAM IS READY
TO ANSWER YOUR
QUESTIONS.**

INFO@WHITEFIRE.BE

**MAKE
MOMENTS
THAT
MATTER**



WHITE FIRE