

ADBE-10220

AB BENCH TRAININGSBANK FÜR BAUCH-TRAINING

ASSEMBLY MANUAL
AUFBAUANLEITUNG



WARNING! ACHTUNG!

EN

• This equipment is made for home use only • Injuries to health may result from incorrect or excessive training. WARNING! Serious injuries, or death, may result if caution is not used • Consult your doctor before performing any exercise program • Keep children and pets away from the device at all times • Ensure the equipment is on a flat, stable and level surface with at least 0.6m of clear area surrounding the equipment • Always wear appropriate exercise clothing and training shoes • The safety level of the equipment can only be maintained if it is examined regularly for damage and wear. Replace defective components immediately and/or keep the equipment out of use until repaired. Pay special attention to components most susceptible to wear. All warnings and instructions must be read and followed prior to use • Keep hair, body, and clothing free and clear of all moving parts • If at any time during exercise you feel faint, dizzy, or experience pain, stop and consult your physician

DE

• Dieses Gerät ist nur für den Heimgebrauch bestimmt • Falsches oder übermässiges training kann zu gesundheitlichen schäden führen. Achtung! Schwere Verletzungen oder Tod können die Folge sein, wenn die Vorsicht nicht angewendet wird • Wenden sie sich an ihren arzt, bevor sie ein trainingsprogramm durchführen • Bewahren sie das gerät stets ausserhalb der reichweite von kindern und haustieren auf • Stellen sie sicher, dass sich das gerät auf einer flachen, stabilen und geraden oberfläche befindet und ein mindestabstand von 0,6 m um das gerät eingehalten wird • Tragen sie stets angemessene sportbekleidung und trainingsschuhe • Das sicherheitsniveau des geräts kann nur gewährleistet werden, wenn es regelmässig auf beschädigungen und verschleiss geprüft wird. Tauschen sie defekte teile umgehend aus bzw. Benutzen sie das gerät erst wieder, wenn es repariert wurde. Achten sie insbesondere auf verschleissanfällige teile. Alle Warnungen und Anweisungen müssen vor der Anwendung gelesen und befolgt werden • Halten Sie Haare, Körper und Kleidung frei und fern von allen beweglichen Teilen • Wenn Sie sich während der Übung zu irgendeinem Zeitpunkt schwach oder schwindelig fühlen oder Schmerzen haben, halten Sie an und konsultieren Sie Ihren Arzt.

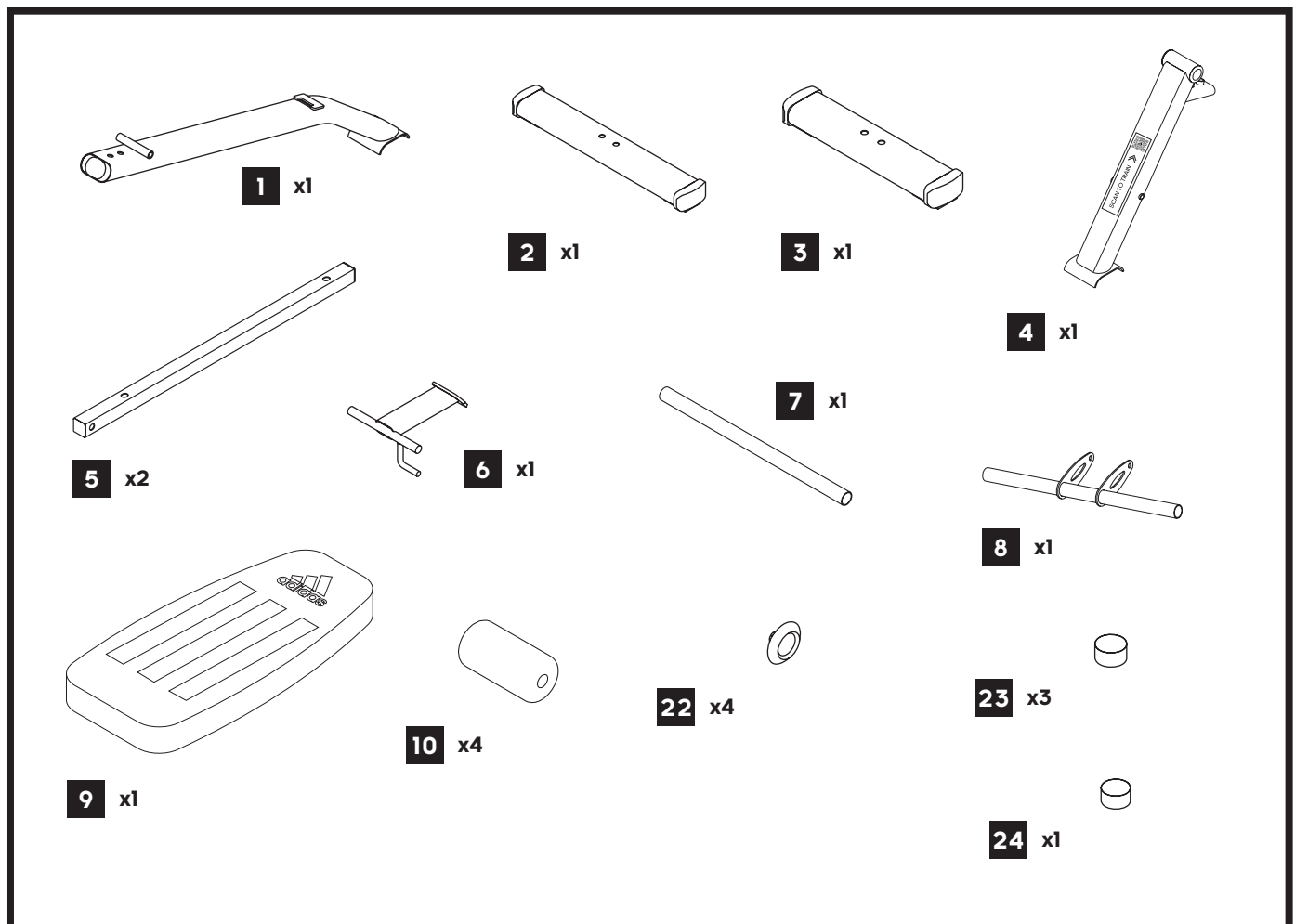

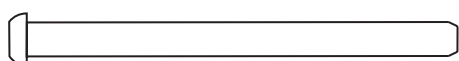

11 x1



15 x3



17 x10



25 x7

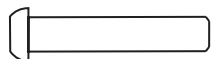

12 x6



16 x1



18 x6



26 x5

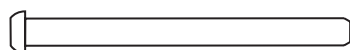

13 x1

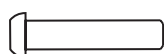

14 x4

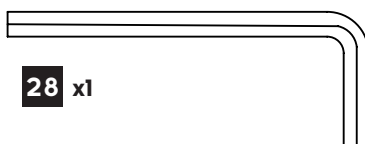

28 x1

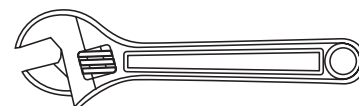

x1











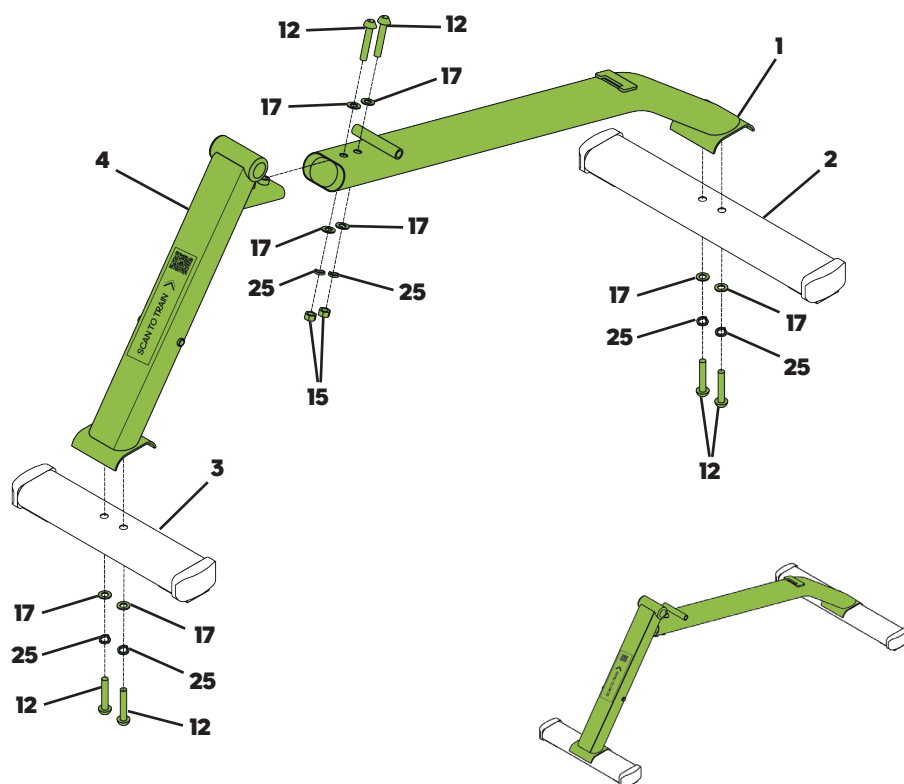

27 x1

NOT INCLUDED:
IM LIEFERUMFANG NICHT ENTHALTEN:

01





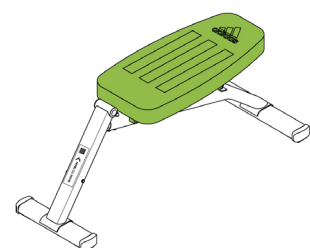
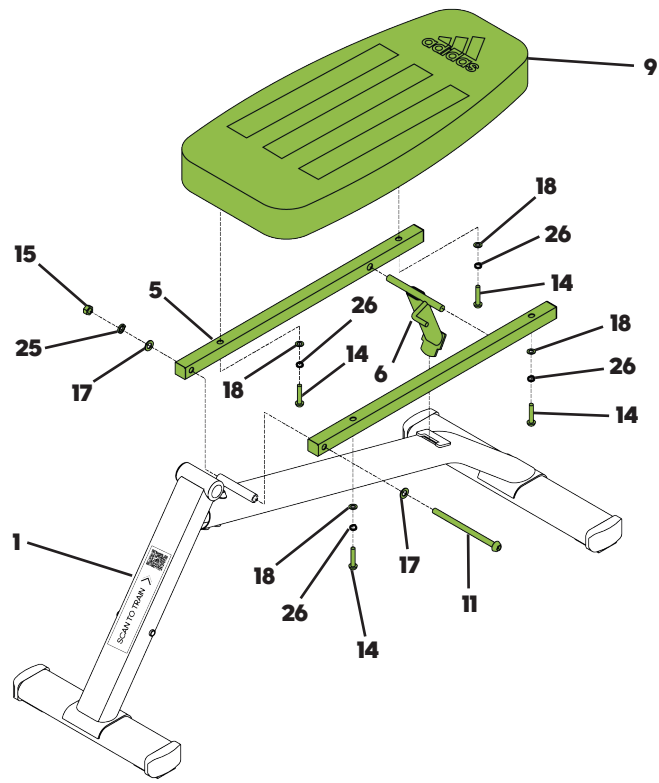

- 12** x6
- 15** x2
- 17** x8
- 25** x6
- 28** x1
- x1**



- 11** x1 
- 14** x4 
- 15** x1 
- 17** x2 
- 18** x4 
- 25** x1 
- 26** x4 
- 27** x1 
- 28** x1 
- x1 



03

- 13 x1 
- 16 x1 
- 18 x2 
- 26 x1 
- 27 x1 
- x1 

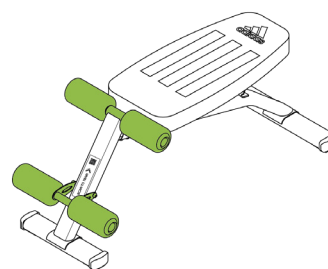
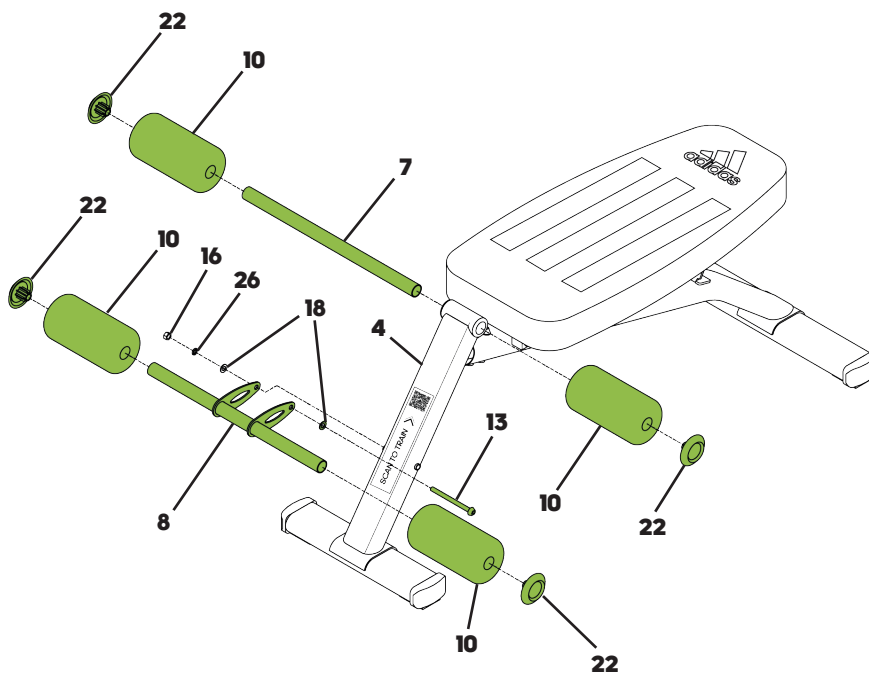

04

23x3 

24x1 

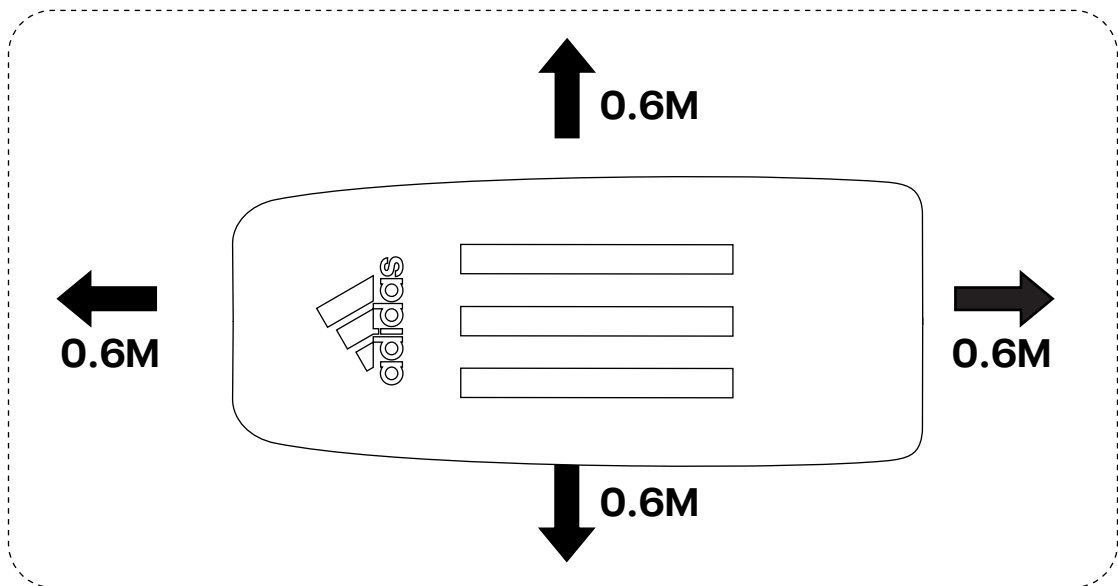
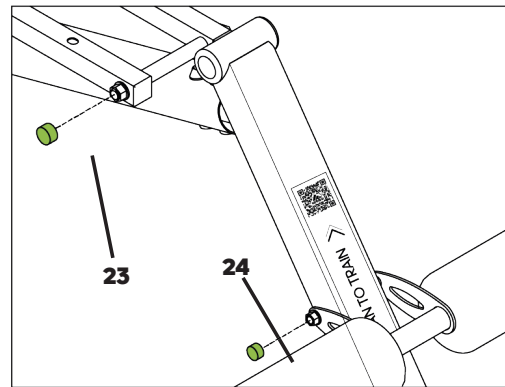
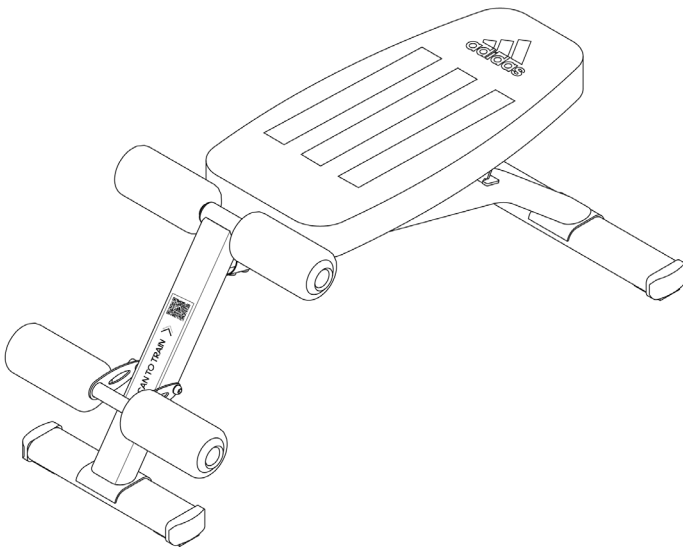

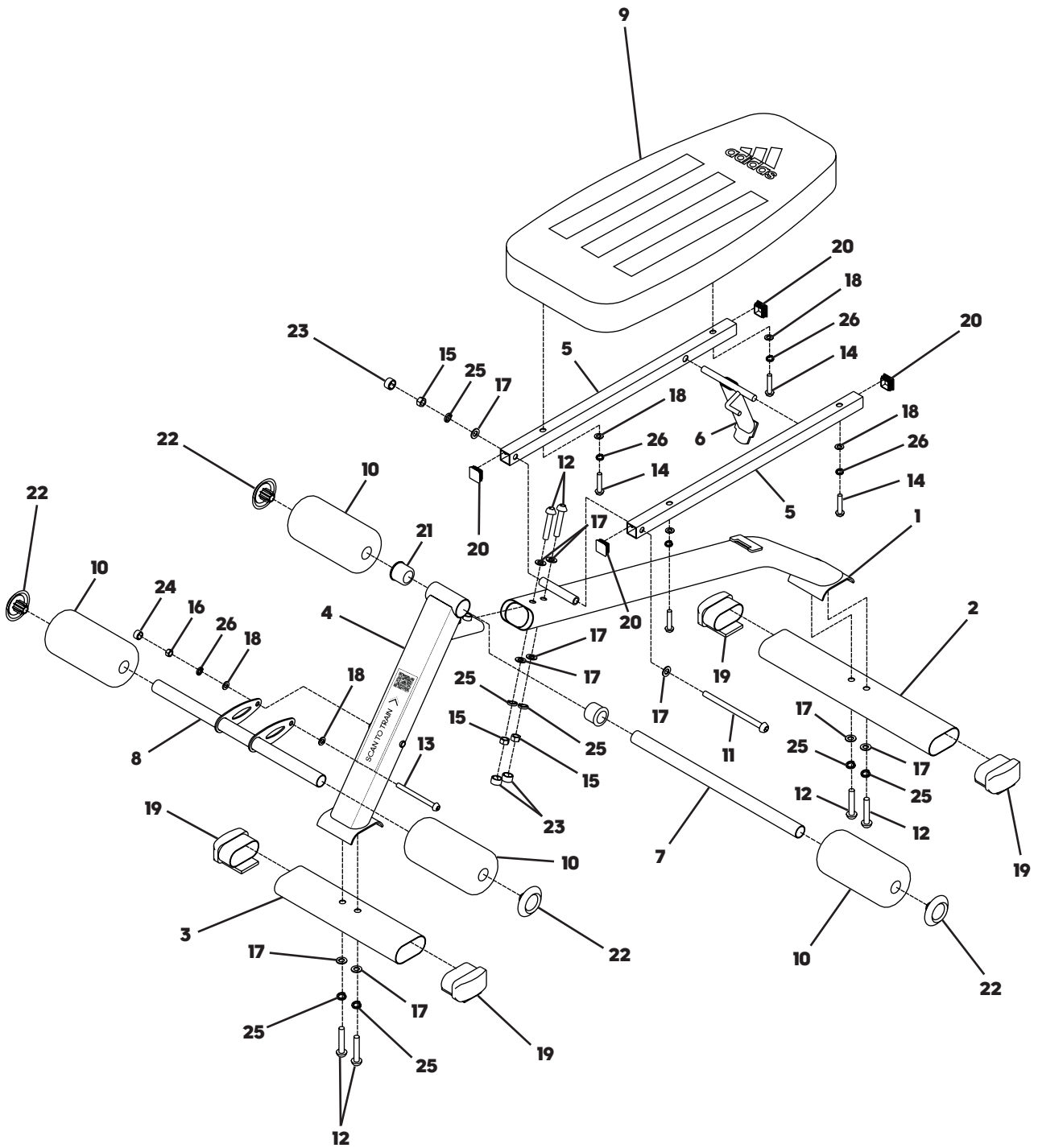

				QTY/ MENGE
1	FMAD612-01	Main Frame	Grundrahmen	1
2	FMAD611-02	Rear Base	Hinterer Fuß	1
3	FMAD611-03	Front Base	Vorderer Rahmen	1
4	FMAD611-04	Front Post	Vorderer Fuß	1
5	FMAD611-05	Backrest Support	Rahmen für Rückenlehne	2
6	FMAD611-06	Backrest Incline Support	Stütze für die Rückenlehne	1
7	FMAD611-07	Foam Tube	Schaumstoffrohr	1
8	FMAD611-08	Foam Tube Frame	Rahmen für Schaumstoffrohr	1
9	FMAD611-09	Backrest Board	Rückenpolster	1
10	FMAD614AB-16	Foam Roll	Schaumstoffrolle	4
11	FMAD611-10	M10x155mm Bolt	M10x155mm Schraube	1
12	PFMCS704MF-13	M10x55mm Bolt	M10x55mm Schraube	6
13	FMAD611-11	M8x105mm Bolt	M8x105mm Schraube	1
14	PFMS80-32	M8x45mm Bolt	M8x45mm Schraube	4
15	PRK1-05	M10 Nylon Locknut	M10 Nylon Gegenmutter	3
16	PHHKRK6-10	M8 Nylon Locknut	M8 Nylon Gegenmutter	1
17	PRK1-06	M10 Washer	M10 Unterlegscheibe	10
18	PFM2006-27	M8 Washer	M8 Unterlegscheibe	6
19	PFMH1001-21	40x80mm Ellipse End Cap	40x80mm Ellipse Endkappe	4
20	PFM2240-32	25mm Square Inner Cap	25mm Vierkant-Innenkappe	4
21	PFM4004-18	38x25mm Round Plastic Bushing	38x25mm Runde Plastikhülse	2
22	FMAD614AB-22	25mm Large Round Inner Cap	25mm runde Innenkappe (groß)	4
23	FMAD614AB-23	M10 Bolt Cover Cap	Abdeckkappe für Schraube M10	3
24	FMAD611-12	M8 Bolt Cover Cap	Abdeckkappe für Schraube M8	1
25	FMAD613-06	M10 Spring Washer	M10 Federscheibe	7
26	FMAD613-07	M8 Spring Washer	M8 Federscheibe	5
27	3B69E00009	Allen Wrench 5#	Inbusschlüssel 5#	1
28	3B69E00010	Allen Wrench 6#	Inbusschlüssel 6#	1



**Product Registration
and Support**

**Registrierung und
Kundendienst**



WWW.ADIDASHARDWARE.COM/PRODUCT-SUPPORT



SCAN TO TRAIN

WWW.ADIDASHARDWARE.COM/PERFORMANCE-BENCHES

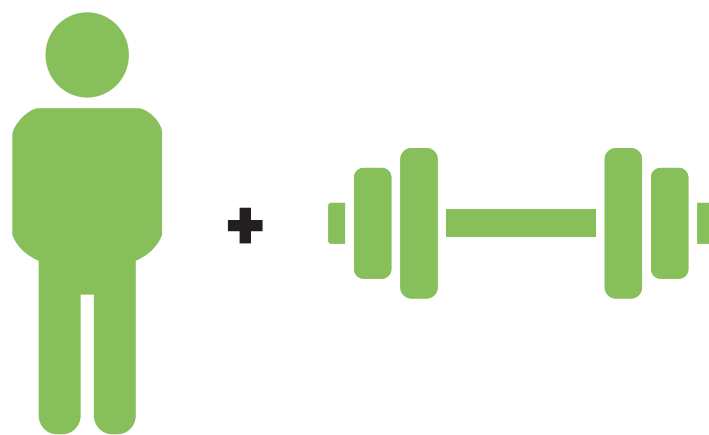

= 175 kg / 385.8 lb

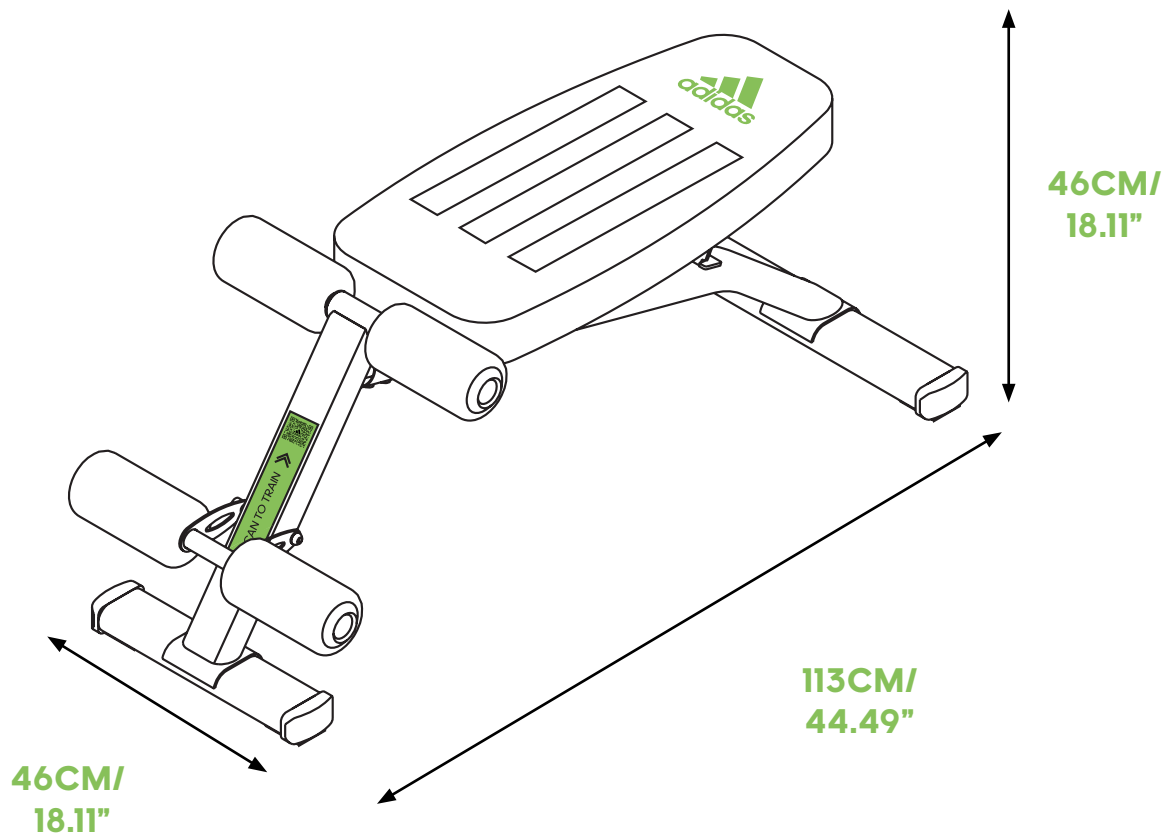



AB BENCH TRAININGSBANK FUR BAUCH TRAINING

For product information or service please contact:

UK: RFE Europa Ltd., 8 Clarendon Drive, Wymbush, Milton Keynes, MK8 8ED, UK.

+44 (0)800 440 2459 / techsupport@rfeinternational.com

Europe: RFE Europa, Linprunstrasse 49, 80335 Munich, Deutschland.

techsupporteu@rfeinternational.com

ES: +34 800 600 816 / serviciotecnico@rfeinternational.com

DE: +49 (0)89 189 39 700 / techsupporteu@rfeinternational.com

APAC (excluding Australia): RFE Asia Pacific, 26F, 2608-2609,

1 Hung To Road, Kwun Tong, Kowloon, Hong Kong.

+852 34685027 / techsupportapac@rfeinternational.com

Australia: techsupportaustralia@rfeinternational.com

China: 上海锐达健身科技发展有限公司 上海市宝山区爱辉路201号 智航创新园 1座 1601 A室,

4007037798 / techsupportchina@rfeinternational.com

USA: RFE Sporting Goods Inc., 445 Plasamour Drive, Suite 1, Atlanta, GA 30324, USA.

+1 (800) 215 6216 / techsupportusa@rfeinternational.com