

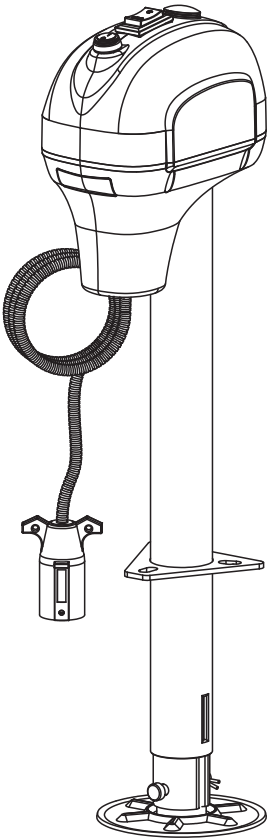

Electric A-Frame Trailer Jack Manual



WARNING:

Read carefully and understand all **INSTRUCTIONS** before operating. Failure to follow the safety rules and other basic safety precautions may result in serious personal injury. Save these instructions in a safe place and on hand so that they can be read when required. Keep these instructions to assist in future servicing.

⚠️ WARNING

CAREFULLY READ THE FOLLOWING INSTALLATION INFORMATION.

NOTICE: Please read and understand all instructions before attempting to install, service, or use this jack.

SPECIFICATIONS

Item No.	GUT045
Maximum Lift Capacity	3500 lbs (continuous use)
Retracted Height	29 1/5"
Vertical Travel	18"
Power Requirements	12V DC
Outer Tube Diameter	2 1/4"
Power Cord Length	48", #12 gauge Wire
Foot Pad Diameter	6"
LED Work Lights For Easy Nighttime Hookups	
Shipping Weight	20lbs

CONTENTS OF KIT:

1. Removable Foot Pad
2. 3/8" Safety Lock Pin
3. Manual Crank Handle
4. Three 3/8" Star Washers

INSTALLATION INSTRUCTIONS

⚠️ WARNING

KEEP HANDS, FEET, AND BODY OUT FROM BENEATH THE JACK & TRAILER TO AVOID THE RISK OF HARM OR FATAL INJURY!

BEFORE INSTALLATION, COMPARE THE LIFT CAPACITY OF THE TONGUE JACK WITH YOUR TRAILER TO ENSURE SAFE OPERATION OF THE JACK.

1. Park the trailer on a level surface and block the trailer tires.
2. Support the trailer tongue by the frame with the jack stands.
3. Insert the electric jack into the jack hole, aligning the bolt holes so the motor housing is facing forward as shown in Fig 1.
4. Attach the jack using three bolts (grade 5, 3/8"-16 UNC bolts with washers and nuts or 3/8"-16 self-tapping bolts are recommended). Place the star washers between the flat washers and mounting plate as shown in Fig 1. The star washers are intended to penetrate through the paint on the mounting plate to ensure direct metal to metal contact. Bolts should be tightened to 15-20 ft-lb.
5. If a lower support plate is not already present, install one in the bottom of the trailer frame.



⚠️WARNING

Do not operate the jack without a lower support plate.

6. Attach foot with 3/8" safety lock pin. Be sure to insert pin through the complete assembly closing safety.
7. Connect 7-pin connector to vehicle's trailer plug, or if hard wiring connect the black positive lead to the positive terminal of the battery. The electric tongue jack is internally grounded, and needs no ground wire if A frame is properly grounded.

OPERATION INSTRUCTIONS

1. Park your trailer on a level surface and block all dolly and trailer tires.

Tip: For night time hookups, flip the light switch ON to illuminate your work area.

2. Before operating the jack, attach the foot with the 3/8" safety lock pin provided.

⚠️WARNING

DO NOT stack blocks under the jack's foot to increase the height. Stacked blocks may become unstable and fall.

The jack must be applied with the original foot, otherwise the jack will be damaged.

3. Normal operation:

- (1) Extend the jack by pressing the UP button.
- (2) Retract the jack by pressing the DOWN button.

NOTE: The jack will not slow down and stop as it approaches the fully retracted position. Release the switch at the first sign of slowing.

⚠️WARNING

DO NOT retract the jack exceeding the STOP limiting mark, otherwise may result in damage of jack.

4. Before driving, remove the foot or position it in the highest position and completely retract the jack.

MANUAL OPERATION INSTRUCTIONS

Park your trailer on a level surface and block all dolly and trailer tires.

Before operating the jack, attach the foot with the 3/8" safety lock pin provided.

1. Disconnect the jack from the power source.
2. Remove the rubber access cover on the top of the jack.
3. Insert the manual crank handle into the access hole on the top of the jack, engaging the drive screw.
4. Rotate the manual crank handle counter-clockwise to extend the jack, and clockwise to retract it.
5. Remove manual crank handle and replace manual override plug.

MAINTENANCE

To keep your jack in good, functional condition, fully extend the jack and clean the inner jack tube once a year. After cleaning, coat the tube with a light grease or silicone spray lubricant. Always avoid high pressure water cleaning to prevent water penetration into components.

TROUBLESHOOTING

CAUSE	SOLUTION
Poor Ground	Clean area between the jack mounting plate and coupler, and ensure paint has been removed by the star washers. Direct metal-to-metal contact must exist between mounting components to ensure good electrical contact.
No or Low Voltage	Check battery & electrical connections. Power supplied must be at least 10V DC. If the battery is low, plug the trailer cable into the tow vehicle, and start the tow vehicle to provide power to the jack.

REPLACEMENT PARTS

REF	DESCRIPTION
A-D	Upper Jack Assembly; includes all housing, gear motor box assembly & items a - d
A	Gearbox
B	Plastic cover assembly
C	Operate switch & Light switch
D	LED light strip
E-J	Lower Jack Assembly; includes outer jack tube, Inner jack tube, screw shaft & items e-j
E	Jack lower assembly (including outer tube, inner tube and screw)
F	25A circuit breaker
G	3/8" safety lock pin
H	Removable foot pad
I	Manual crank handle
J	3/8" Star Washers
K	7-pin connector

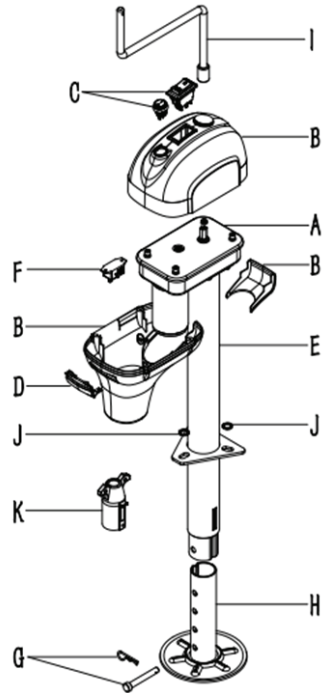

Great Circle USA
 Support Line: 1-866-493-0524
 superhandy@greatcircleus.com
 www.greatcircleus.com