



Oil Control Valve Operator's Manual



WARNING:

Read carefully and understand all INSTRUCTIONS before operating. Failure to follow the safety rules and other basic safety precautions may result in serious personal injury. Save these instructions in a safe place and on hand so that they can be read when required. Keep these instructions to assist in future servicing.



GENERAL SAFETY REGULATIONS



WARNING: The warnings, cautions, and instructions discussed in this instruction manual cannot cover all possible conditions or situations that could occur. It must be understood by the operator that common sense and caution are factors that cannot be built into this product but must be supplied by the operator.

1. Keep the work area clean and dry. Damp or wet work areas can result in injury.
2. Keep children away from work area. Children to handle this product without adequate adult supervision.
3. Use the right tool for the job. Do not attempt to force small equipment to do the work of larger industrial equipment. There are certain applications for which this equipment was designed. It will do the job better and more safely at the capacity for which it was intended. Do not modify this equipment, and do not use this equipment for any purpose other than for what is was intended.
4. Check for damaged parts. Before using this product, carefully check that it will operate properly and perform its intended function. Check for damaged parts and any other conditions that may affect the operation of this product. Replace damaged or worn parts immediately.
5. Do not overreach when using the product. Maintain proper footing and balance at all times to prevent tripping, falling, back injury, etc.
6. DO NOT use the equipment when tired or under the influence of drugs, alcohol, or medication. A moment of inattention while operating this equipment may result in serious personal injury.

TECHNICAL DETAILS

Item No.	GUL009
Inlet connection	1/2"
Fluid Range	0.3~9.25gpm
Pressure Range	70-725psi
Temperature	Min. -10°C Max. 60°C
Precision	±0.5%
Viscosity	8-5000mps
Power source	1x3V CR2 battery
Rigid tube	—
Flexible hose	■
Manual tip	—
Automatic tip	■
Digital meter	■
Inlet Connection	NPT

INSTALLATION

1. Control valve is 1/2" oil inlet. When connecting with hose fitting, please remember to apply teflon tape for an improved seal.

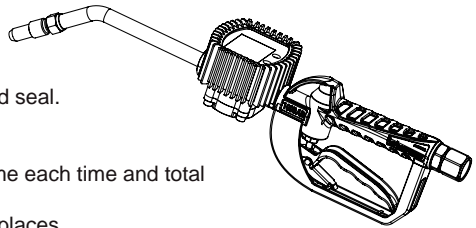

METER

- 5-digit liquid crystal display for both volume each time and total
- 4 units options: L, GAL, PT and QT
- Accurate out to two to the second decimal places
- Low battery indicator
- 2 buttons: "Move", "Reset"

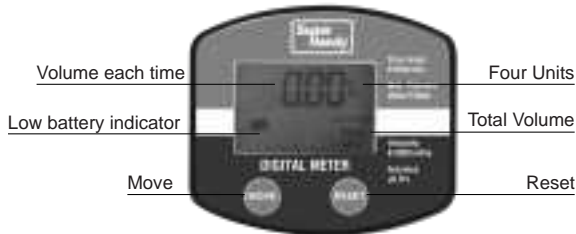

Attn: Do not apply the meter as a measuring tool for commercial trading.

DETAILS OF OPERATION

1. BEFORE PUTTING INTO OPERATION

- Check the technical data of the installation match with those of the lube meter. For example, connections, pressure, flow range and medium. Use the formula: Proper correction factor = (actual value / displayed value) x current correction factor to decide the right connection factor, then set the proper correction factor (refer to 3. Button usage part)
- Once the meter has been installed, please make sure that no air pressure shocks, or particles can damage the meter
- Please check all connections to avoid leakage.

2. CHANGE THE BATTERY

- Battery type: Lithium CR2, 3V/1400mAh.
- Change the battery like below when the low battery signal is flashing on the display.
- Remove the protector cover, loosen the securing screw.
- Change the battery and secure the lid on again.

USER BUTTONS

The turbine digital meter features two buttons (MOVE and RESET) which individually perform two main functions and together, other secondary functions.

The main functions performed are:

For the reset key, resetting the Partial Register and resetting the table total (reset total) for the move key, and entering instrument calibration mode.

Depressing both keys together permit entering configuration mode.

LCD DISPLAY

KEY

① Partial register (5 figures with moving comma from 0.1 to 99999)

Indicating the volume dispensed since the reset button was last pressed.

② Indication of battery charge

③ Indication of calibration mode

④ Indication of resetting present total to Zero

⑤ Total register

⑥ Indication of flow rate mode

⑦ Indication of unit of measurement of partial: L= Litres , GAL = Gallons, PT = Pints, and QT = Quarts.

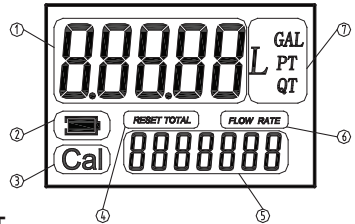

DAILY USE

BUTTON USAGE, CALIBRATION AND MEASUREMENT UNIT CHANGE

• Reset the present total (See Fig. 4)

- 1) When the meter is on standby, press the RESET key.
- 2) The display shows all the segments.
- 3) The meter resets the present total already.

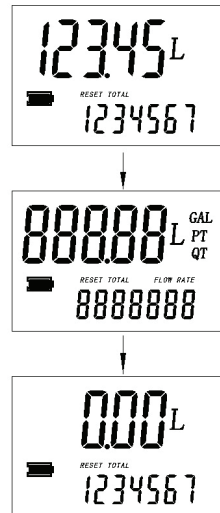

Fig. 4

- **Show current correction factor and general total (See Fig. 5)**

Press MOVE and RESET together and hold for less than 3 seconds. Value "1.4000" is the correction factor which can be reset; "1234567" is the general total which cannot be reset.



Fig. 5

- **Measurement unit change (See Fig. 6)**

Press MOVE and RESET together and hold for more than 3 seconds.

Zone 7 on the display is the current unit. Press RESET to chose a different measurement unit and then press MOVE and hold for more than 3 seconds to confirm.

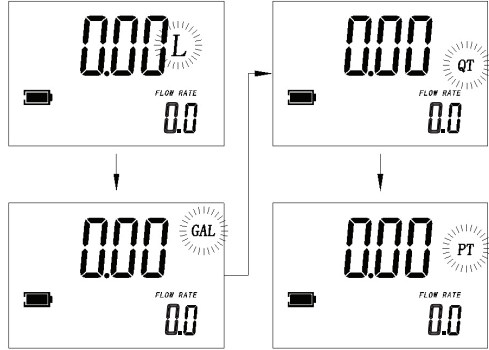

Fig. 6

- **Reset The Resettable Total (See Fig. 7)**

When the meter is on standby, press the RESET key for more than 3 seconds to reset the present total first.

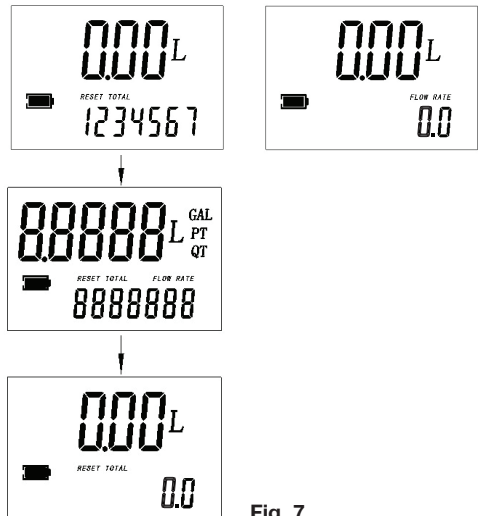

Fig. 7

PROCEDURE FOR ENTER THE CORRECTION FACTOR DIRECTLY

Carefully follow the procedure indicated below.

FORMULA

Proper correction factor = current correction factor × (actual value / display value)





Example:

Actual value 20.75



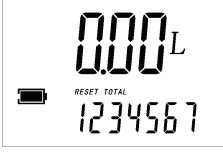

Display value 18.96

Current correction factor 1.000

Proper correction factor 1.000 × (20.75 / 18.96) = 1.000 × 1.094 = 1.094

1	Wait for the meter to go standby.	
2	Reset the resettable total.	
3	Press the MOVE key. Keep it pressed until it shows similar to the right image (the digit flash in ① zone), which means the meter is under the calibration mode.	
4	Press the RESET key to choose the right digit from 0 to 9. Press the MOVE key to start the next digit. So the digit of correction factor can be changed one by one.	
5	Make sure the correction factor is right, press the MOVE key. Keep it pressed until the indication of calibration mode quits and the factor is saved.	

MODIFY THE CORRECTION FACTOR IN FIELD
PLEASE CAREFULLY FOLLOW THE PROCEDURE INDICATED BELOW.

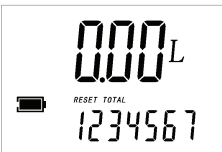
1	Wait for the meter to go standby.	
2	Reset the resettable total.	
3	Start dispensing into a measuring glass. Stop dispensing when over 5 Litres of volume is reached, read out the actual value. The volume that is displayed on the LCD is the Display Value, not the Actual Value which may be slightly higher. For example, in the figure on the right, the Display Value is 18.96 while the Actual Value is 20.75.	
4	Press the MOVE key. Keep it pressed until it shows as the right fig., with the digit flashing in ① zone. Press the MOVE key to go the the next digit so that the Actual Value can be input.	 
5	Make sure the correction factor is right and then press the MOVE key. Keep it pressed until calibration is finished and the factor is save. The meter will then return to to be on standby.	

USAGE INSTRUCTION

(1) Start:

Turn on the trigger to make the oil transmission.

(2) Keep the status:

Push the lock ahead, then the transmission can be kept when the trigger is released.

(3) Finish:

a. If the lock is not used, release your hand, the trigger will turn off and finish the transmission.

b. If the lock is used, please turn on the trigger once again, the lock will stop working. Then turn off the trigger, release your hand, the transmission will be finished.

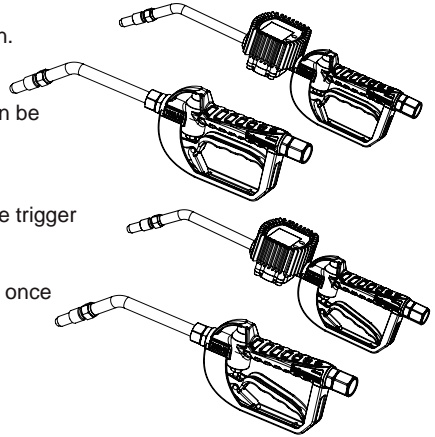

Notes When Using:

Cautions:

1. For working condition, please refer to the specification parameter list. Temperature: -10°C~60°C
2. Media: Lubricant Oil,.

OIL CONTROL VALVE EXPLODED DRAWING

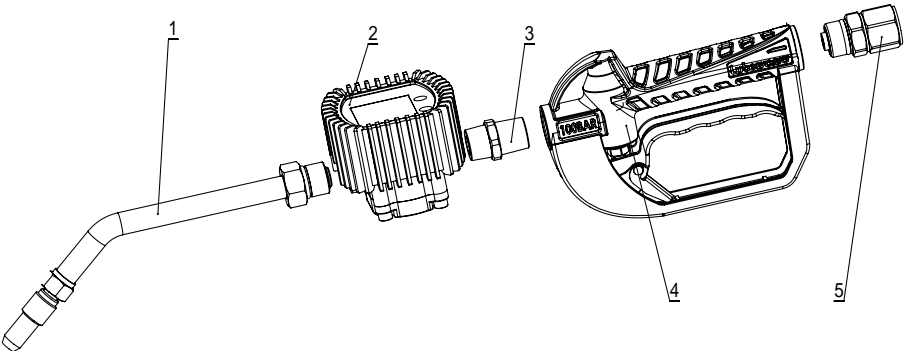

Part No.	Description	Q'ty	Part No.	Description	Q'ty
1	Spout	1	4	Handle Body	1
2	Meter	1	5	Swivel Fitting	1
3	Adapter	1			

Note: digital oil control valve part

MAINTENANCE

If any problem, please contact your local service center.

TROUBLE SHOOTING GUIDE

Relieve the pressure before you check or repair the dispensing valve. Be sure all other valves and controls and the pump are operating properly.

To reduce the risk of serious injury whenever you are instructed to relieve pressure, always follow the pressure relief procedure on page 3.

Problem	Problem	Solution
Slow or no fluid flow	Filter is clogged, or pump pressure is low, or shut-off valve is not fully open, or foreign materials jammed in the metering element.	<ol style="list-style-type: none"> 1. Relieve the pressure. 2. Loose swivel fitting, clean or replace the filter. 3. If the problem remains, contact your distributor for repair or replacement.
Oil leaks from swivel	Swivel is loose	Torque the swivel If the problem remains, contact your distributor for repair or replacement
	O-ring is worn or damaged	Replace the O-ring. If the problem remains, contact your distributor for repair or replacement
Oil drips from nozzle	Nozzle is damaged or obstructed	Inspect the nozzle for damage or obstructions, and replace if damaged If the problem remains, contact your distributor for repair or replacement
Valve leaks	O-rings or valve seat are worn or damaged	Replace the O-rings and/or the valve seat. If the problem remains, contact your distributor for repair or replacement
Leakage from meter	O-ring damaged	<ol style="list-style-type: none"> 1. Take meter off from the dispense system 2. Take off the protector 3. Loosing four the socket head cap screws on the cover of the meter 4. Loosen eight the hex bolts on the bottom of the meter 5. Take off the seat 6. Check the O-ring, replacing the O-ring if it is damaged 7. After replacing the O-ring, assemble the meter and fix it back to the dispense system
No Display	Loosing Battery	<ol style="list-style-type: none"> 1. Take meter off from the dispense system 2. Take off the protector 3. Take off the labels sticks on the bottom of the meter 4. Loosing the five socket head cap screws on the bottom of the meter 5. Take off the seat 6. Check the battery, replacing the battery if it is out of power 7. After replacing the battery, assemble the meter and fix it back to the dispense system
	Battery out of power	
Wrong Reading	Correction coefficient error	Reset the correction factor (follow the instructions on Page 6)



WARNING: Your risk from these exposures varies, depending on how often you do this type of work. To reduce your exposure to these chemicals: work in a well-ventilated, and work with approved safety equipment, such as those dust masks that are specially designed to filter out microscopic particles.

EXPLODED AND PARTS LIST

(Meter Exploded Drawing)

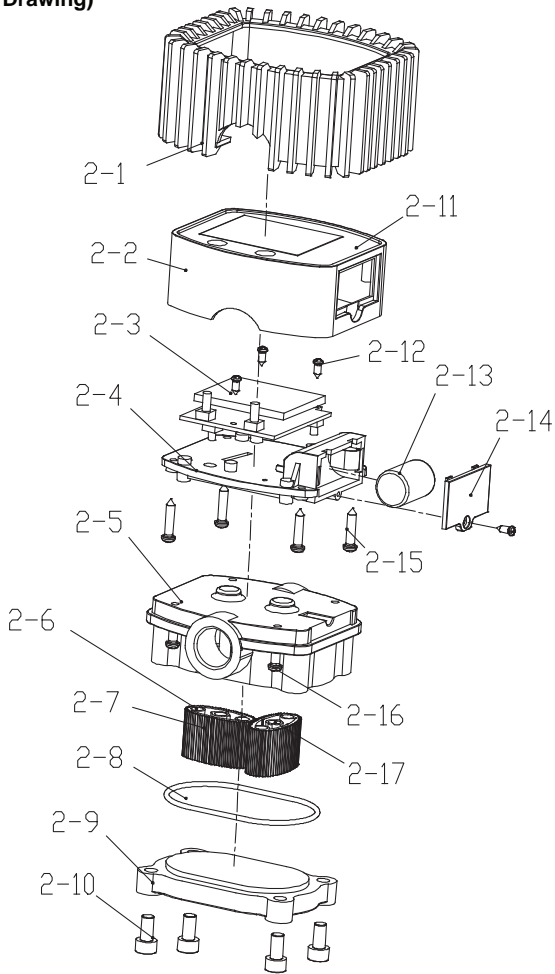

Part No.	Description	Q'ty	Part No.	Description	Q'ty
2-1	Rubber Protector	1	2-10	Screw	4
2-2	Meter Cover	1	2-11	Label	1
2-3	Main Circuit Board	1	2-12	Screw	4
2-4	Fix Board	1	2-13	Battery	1
2-5	Seat	1	2-14	Battery Cover	1
2-6	Magnetic Rod	2	2-15	Screw	4
2-7	Oval Gear	2	2-16	Screw	4
2-8	O-ring	1	2-17	Shaft	2
2-9	Meter Holder	1			

EXPLODED AND PARTS LIST

(Valve Body Exploded Drawing)

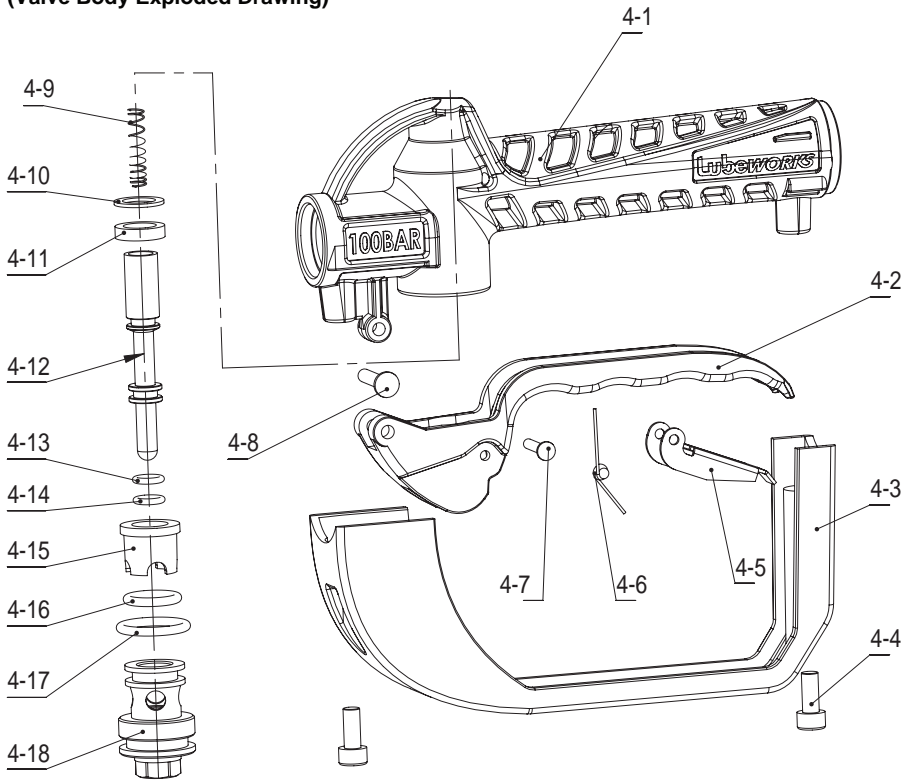

Part No.	Description	Q'ty	Part No.	Description	Q'ty
4-1	Handle Body	1	4-10	Washer	1
4-2	Trigger	1	4-11	Seal	1
4-3	Grip	1	4-12	Slip Pole	1
4-4	Screw	2	4-13	O Ring	1
4-5	Trigger Lock	1	4-14	O Ring	1
4-6	Clip	1	4-15	Bushing	1
4-7	Pin	1	4-16	O Ring	1
4-8	Pin	1	4-17	O Ring	1
4-9	Spring	1	4-18	Piston Sleeve	1



Great Circle USA
Support Line: 1-866-493-0524
help@greatcircleus.com
www.greatcircleus.com