

Operating Manual

SUNNY ISLAND 3.0M / 4.4M / 6.0H / 8.0H SUNNY REMOTE CONTROL

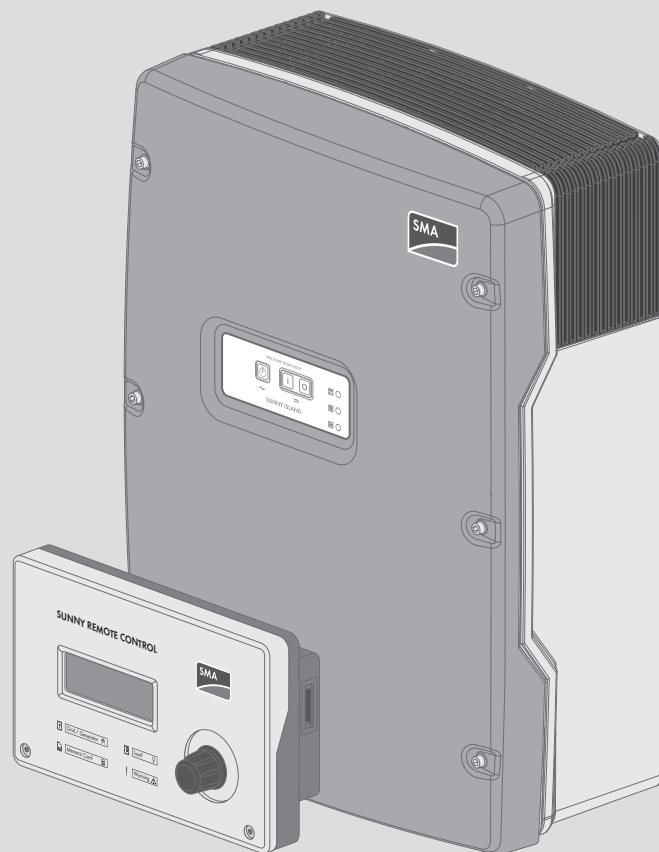

Legal Provisions

The information contained in these documents is property of SMA Solar Technology AG. Any publication, whether in whole or in part, requires prior written approval by SMA Solar Technology AG. Internal reproduction used solely for the purpose of product evaluation or other proper use is allowed and does not require prior approval.

SMA Warranty

You can download the current warranty conditions from the Internet at www.SMA-Solar.com.

Trademarks

All trademarks are recognized, even if not explicitly identified as such. Missing designations do not mean that a product or brand is not a registered trademark.

Modbus® is a registered trademark of Schneider Electric and is licensed by the Modbus Organization, Inc.

QR Code is a registered trademark of DENSO WAVE INCORPORATED.

Phillips® and Pozidriv® are registered trademarks of Phillips Screw Company.

Torx® is a registered trademark of Acument Global Technologies, Inc.

SMA Solar Technology AG

Sonnenallee 1

34266 Niestetal

Germany

Tel. +49 561 9522-0

Fax +49 561 9522-100

www.SMA.de

Email: info@SMA.de

Copyright © 2016 SMA Solar Technology AG. All rights reserved.

Table of Contents

1	Information on this Document	7
1.1	Validity	7
1.2	Target group	7
1.3	Symbols.....	7
1.4	Typographies.....	8
1.5	Nomenclature	8
2	Safety.....	10
2.1	Intended Use.....	10
2.2	Safety Information	10
2.3	Information on Handling Batteries.....	12
3	Product Description.....	15
3.1	Sunny Island.....	15
3.2	Control Panel of the Sunny Island Inverter.....	16
3.3	Type Label.....	17
3.4	Sunny Remote Control.....	18
4	Starting and Stopping the System.....	20
4.1	Switching on the Sunny Island.....	20
4.2	Starting the System	20
4.3	Stopping the System.....	20
4.4	Switching Off the Sunny Island.....	21
4.5	Tripping the Emergency Disconnection of the System.....	21
4.6	Setting Time-Controlled Inverter Operation in Off-Grid Systems.....	22
5	Operation of the Sunny Island Inverter with the Sunny Remote Control	23
5.1	Display Modes	23
5.2	Standard Mode.....	24
5.2.1	Display of Operating States.....	24
5.2.2	Information Page in Systems for Increased Self-Consumption and Battery Backup Systems	25
5.2.3	Information Page in Off-Grid Systems	26
5.3	User Mode.....	29
5.3.1	Pages in the User Mode.....	29
5.3.2	Displaying Parameters and Operating and Setting the System.....	30
5.4	Installer Mode and Expert Mode.....	32
5.4.1	Switching to Installer Mode or Expert Mode	32
5.4.2	Exiting Installer Mode or Expert Mode	32
5.4.3	Menus in Installer and Expert Mode	33
5.4.4	Parameter Page in Installer and Expert Mode	33
5.4.5	Selecting Menus and Parameters.....	33
5.4.6	Setting Parameters	34
5.4.7	Directly Accessing the Parameters	34
6	Operation of the Sunny Island Inverter with a Communication Product.....	36
7	Data Storage and Firmware Update	37
7.1	Data Storage on the Computer	37
7.2	Data Storage on SD Memory Card.....	37
7.2.1	Insert the SD Memory Card	37

7.2.2	Loading and Saving Parameters	37
7.2.3	Saving the Event History and Error History	38
7.2.4	Displaying the SD Memory Card Status Message	38
7.2.5	Removing the SD Memory Card	38
7.2.6	Displaying the SD Memory Card Content.....	38
7.3	Firmware Update.....	40
7.3.1	Display of the Firmware Version	40
7.3.2	Updating the Firmware Using an SD Memory Card	40
7.3.3	Updating the Firmware Using Sunny Explorer	41
7.3.4	Performing a Remote Update Using the Sunny Home Manager.....	41
8	Manually Controlling the Generator	43
8.1	Starting the Generator with Sunny Remote Control	43
8.2	Stopping the Generator with Sunny Remote Control.....	43
8.3	Starting the Generator without Autostart Function	43
8.4	Stopping the Generator without Autostart Function	44
9	Disconnecting the Sunny Island from Voltage Sources.....	45
10	Troubleshooting	46
10.1	Display of Errors	46
10.1.1	Display of Errors on the Sunny Remote Control	46
10.1.2	Display of Errors on the Communication Product (Example)	46
10.2	Sunny Island Inverter Behavior Under Fault Conditions.....	47
10.3	Acknowledge Errors.....	47
10.4	Logged Events.....	48
10.4.1	Sunny Island Category (1xx)	48
10.4.2	Battery Category (2xx).....	48
10.4.3	Generator Category (4xx)	49
10.4.4	Utility Grid Category (5xx).....	49
10.4.5	Relay Category (6xx)	49
10.4.6	System Category (7xx).....	50
10.4.7	External Device and Component Category (8xx)	51
10.4.8	Category External Events (9xx).....	51
10.5	Logged Warning Messages and Error Messages	52
10.5.1	Sunny Island Category (1xx)	52
10.5.2	Battery Category (2xx).....	57
10.5.3	Generator or Utility Grid Category (3xx)	59
10.5.4	Generator Category (4xx)	67
10.5.5	Utility Grid Category (5xx).....	68
10.5.6	Relay Category (6xx)	68
10.5.7	System Category (7xx).....	68
10.5.8	External Device and Component Category (8xx)	73
10.5.9	General Category (9xx).....	83
10.6	Frequently Asked Questions (FAQs)	86
10.6.1	Questions Regarding the Sunny Island.....	86
10.6.2	Questions Regarding the Sunny Remote Control.....	86
10.6.3	Questions Regarding the Battery	87
10.6.4	Questions Regarding the Generator.....	87
10.6.5	Questions Regarding Multicluster Systems.....	88
10.7	Charging the Battery After Automatic Shutdown in Off-Grid Systems (Emergency Charge Mode)	89

10.8	Changing Slave Addresses in a Cluster.....	91
11	Cleaning and Maintenance.....	93
11.1	Cleaning and Checking the Sunny Island Inverter Enclosure.....	93
11.2	Cleaning the Sunny Remote Control.....	93
11.3	Performing a Manual Equalization Charge in the Off-Grid System.....	93
11.4	Checking the Function.....	93
11.5	Checking the Connections.....	94
11.6	Checking and Maintaining the Battery.....	94
11.7	Cleaning the Fans.....	95
11.8	Replacing the Battery.....	97
12	Decommissioning the Sunny Island.....	100
13	Parameters in Sunny Remote Control.....	102
13.1	Directory of the Parameters in User Mode.....	102
13.1.1	Inverter Category.....	102
13.1.2	Battery Category.....	103
13.1.3	Generator Category.....	104
13.1.4	Grid Category.....	105
13.1.5	SI Charger Category.....	105
13.1.6	Self Cnsmptn Category.....	106
13.1.7	Grid Cnsmptn Category.....	106
13.1.8	Grid Feed Category.....	106
13.1.9	Loads Category.....	106
13.1.10	PV System Category.....	107
13.1.11	System Category.....	107
13.1.12	Time Category.....	107
13.1.13	Identity Category.....	108
13.1.14	Password Category.....	108
13.2	Directory of the Parameters in Installer Mode and Expert Mode.....	108
13.2.1	Display Values.....	108
13.2.1.1	Inverter (110#).....	108
13.2.1.2	Battery (120#).....	112
13.2.1.3	External (130#).....	113
13.2.1.4	Charge Controller (140#).....	116
13.2.1.5	Compact (150#).....	118
13.2.1.6	SlfCsmptn (160#).....	120
13.2.1.7	Multicluster (170#).....	122
13.2.2	Adjustable Parameters.....	124
13.2.2.1	Inverter (210#).....	124
13.2.2.2	Battery (220#).....	125
13.2.2.3	External/Backup (230#).....	129
13.2.2.4	Relay (240#).....	141
13.2.2.5	System (250#).....	145
13.2.2.6	SlfCsmptnBackup (#260).....	147
13.2.2.7	Authent (270#).....	149
13.2.3	Information (300#).....	149
13.2.3.1	Inverter (310#).....	149
13.2.3.2	Battery (320#).....	152
13.2.3.3	External (330#).....	154
13.2.4	Report (400#).....	155
13.2.5	Operation (500#).....	155

13.2.5.1	Inverter (510#)	155
13.2.5.2	Battery (520#)	156
13.2.5.3	Generator (540#)	157
13.2.5.4	MMC Card (550#)	157
13.2.5.5	Grid (560#)	157
14	Parameters in the Communication Product	158
15	Menu Structure	159
15.1	User Mode	159
15.2	Installer Mode and Expert Mode	160
16	Contact	161

1 Information on this Document

1.1 Validity

This document is valid for the following device types:

- SI3.0M-11 (Sunny Island 3.0M) from firmware version 3.2
- SI4.4M-11 (Sunny Island 4.4M) from firmware version 3.2
- SI6.0H-11 (Sunny Island 6.0H) from firmware version 3.1
- SI8.0H-11 (Sunny Island 8.0H) from firmware version 3.1
- SRC-20 (Sunny Remote Control)

1.2 Target group

This document is intended for qualified persons and operators. Only qualified persons are allowed to perform the activities marked in this document with a warning symbol and the caption "Qualified person". Activities that may also be performed by operators are not marked and may be performed by operators.

Operator





Operators must be given training on the following subjects by qualified persons:







- Training on the dangers involved in handling electrical devices
- Training on operation of the Sunny Island
- Training on the safe handling of batteries
- Training on secure disconnection of the Sunny Island under fault conditions
- Training on how to secure a system against unintentional reactivation
- Training on the maintenance and cleaning of the Sunny Island inverter
- Knowledge of and compliance with this document and all safety information

Qualified Persons

- Training in how to deal with the dangers and risks associated with installing and using electrical devices and batteries
- Training in the installation and commissioning of electrical devices
- Knowledge of and adherence to the local standards and directives
- Knowledge of and compliance with the documentation of the Sunny Island inverter with all safety information

1.3 Symbols

Symbol	Explanation
 DANGER	Indicates a hazardous situation which, if not avoided, will result in death or serious injury
 WARNING	Indicates a hazardous situation which, if not avoided, can result in death or serious injury
 CAUTION	Indicates a hazardous situation which, if not avoided, can result in minor or moderate injury
NOTICE	Indicates a situation which, if not avoided, can result in property damage
 QUALIFIED PERSON	Information advising that the following section contains activities that may be performed only by qualified persons.

Symbol	Explanation
	This information is relevant for systems which are to be operated in parallel with utility grid. (e.g. SMA Flexible Storage System).
	Content is relevant for off-grid systems.
	Information that is important for a specific topic or goal, but is not safety-relevant
	Indicates a requirement for meeting a specific goal
	Desired result
	A problem that might occur

1.4 Typographies

Typography	Use	Example
bold	<ul style="list-style-type: none"> • Display messages • Parameter • Terminals • Slots • Elements to be selected • Elements to be entered 	<ul style="list-style-type: none"> • Connect the grounding conductor to AC2 Gen/ Grid. • Select the parameter 235.01 GnAutoEna and set to Off.
>	<ul style="list-style-type: none"> • Several elements that are to be selected 	<ul style="list-style-type: none"> • Select 600# Direct Access > Select Number.
[Button]	<ul style="list-style-type: none"> • Button that is to be selected or clicked on 	<ul style="list-style-type: none"> • Select [Enter].
[Key]		

1.5 Nomenclature

Complete designation	Designation in this document
Off-grid system, battery-backup system, system for increased self-consumption	System
Sunny Boy, Sunny Mini Central, Sunny Tripower	PV inverter
Sunny Explorer, Sunny Portal, Sunny Home Manager	Communication product
Grid failure or deviation from the country-specific thresholds for voltage and frequency	Grid failure
Automatic transfer switch with battery-backup function	Automatic transfer switch
Grid-forming generators such as electric generators or utility grids	External energy sources

Menus are presented as follows: menu number, pound sign and menu name (e.g., **150# Compact Meters**).

Parameters are presented as follows: menu number, period, parameter number and parameter name (e.g., **150.01 GdRmgTm**). The term "parameter" includes parameters with configurable values as well as parameters for displaying values.

2 Safety

2.1 Intended Use

Sunny Island

The Sunny Island is a battery inverter that controls the electrical energy balance in an off-grid system, in a battery-backup system or in a system for increased self-consumption. In a battery-backup system, you can also use the Sunny Island for increased self-consumption.

The product is suitable for indoor and outdoor use.

The Sunny Island is not suitable for supplying life-sustaining medical devices. A power outage must not lead to personal injury.

The Sunny Island uses batteries for energy storage. The nominal voltage of the battery must correspond to the input voltage on the DC connection. A fuse switch-disconnector (e.g., BatFuse) must be installed between the battery and the Sunny Island. With lead-acid batteries, the battery room must be ventilated in accordance with the requirements of the battery manufacturer and with the locally applicable standards and directives (see documentation of the battery manufacturer).

If connecting a lithium-ion battery, the following must be observed:

- The lithium-ion battery must comply with the locally applicable standards and directives and be intrinsically safe.
- The battery management of the lithium-ion battery is compatible with the Sunny Island (see the technical information at "List of Approved Lithium-Ion Batteries").

Use this product only in accordance with the information provided in the enclosed documentation and with the locally applicable standards and directives. Any other application may cause personal injury or property damage.

Alterations to the product, e.g. changes or modifications, are only permitted with the express written permission of SMA Solar Technology AG. Unauthorized alterations will void guarantee and warranty claims and in most cases terminate the operating license. SMA Solar Technology AG shall not be held liable for any damage caused by such changes.

Any use of the product other than that described in the Intended Use section does not qualify as appropriate.

The enclosed documentation is an integral part of this product. Keep the documentation in a convenient place for future reference and observe all instructions contained therein.

The type label must remain permanently attached to the product.

Sunny Remote Control

You can configure and control the system from a central location using the Sunny Remote Control display.

Use this product only in accordance with the information provided in the enclosed documentation and with the locally applicable standards and directives. Any other application may cause personal injury or property damage.

Alterations to the product, e.g. changes or modifications, are only permitted with the express written permission of SMA Solar Technology AG. Unauthorized alterations will void guarantee and warranty claims and in most cases terminate the operating license. SMA Solar Technology AG shall not be held liable for any damage caused by such changes.

Any use of the product other than that described in the Intended Use section does not qualify as appropriate.

The enclosed documentation is an integral part of this product. Keep the documentation in a convenient place for future reference and observe all instructions contained therein.

The type label must remain permanently attached to the product.

2.2 Safety Information

This section contains safety information that must be observed at all times when working on or with the product.

To prevent personal injury and property damage and to ensure long-term operation of the product, read this section carefully and observe all safety information at all times.

⚠ DANGER**Danger to life from electric shocks due to live voltage and risk of injury from short-circuit currents**

High voltages are present inside the Sunny Island inverter. When the enclosure lid is removed, live components can be touched that can result in death or serious injury due to electric shock. Short-circuit currents in the battery can cause heat build-up and electric arcs. Burns or eye injuries due to flashes may result.

- When carrying out any work on the electrical installation, wear suitable personal protective equipment.
- Switch off or disconnect the following components in the following order:
 - Sunny Island
 - The control and measurement voltages in the distribution board of the Sunny Island circuit breakers
 - Load-break switch of the battery
- Ensure that the system cannot be reconnected.
- Open the enclosure lid of the Sunny Island and ensure that no voltage is present.
- Ground and short-circuit the AC conductors outside the Sunny Island inverter.
- Cover or isolate any adjacent live components.

⚠ WARNING**Danger to life from electric shock due to damaged inverter**

Operating a damaged inverter can lead to hazardous situations that can result in death or serious injuries due to electric shock.

- Only use inverter when it is technically faultless and in an operationally safe state.
- Check the inverter regularly for visible damage.
- Make sure that all external safety equipment is freely accessible at all times.
- Make sure that all safety equipment is in good working order.

⚠ WARNING**Risk of crushing injuries due to moving PV array parts**

Moving parts in the PV array can crush or sever body parts. A generator can be started automatically by the Sunny Island.

- Operate the generator only with the safety equipment.
- Carry out work on the generator in accordance with the manufacturer's specifications.

⚠ CAUTION**Risk of burns due to short-circuit currents on the disconnected Sunny Island**

The capacitors in the DC connection input area store energy. After the battery is isolated from the Sunny Island, battery voltage is still temporarily present at the DC connection. A short circuit at the DC terminal can lead to burns and may damage the Sunny Island inverter.

- Wait 15 minutes before performing any work at the DC terminal or on the DC cables. This allows the capacitors to discharge.

⚠ CAUTION**Risk of burns due to hot components**

Some components of the inverter can become very hot during operation. Touching these components can cause burns. Heat build-up can cause burns.

- During operation, do not touch any parts other than the enclosure lid of the inverter.
- After opening the inverter, wait until the component parts have cooled down.

NOTICE**Damage to the inverter due to electrostatic discharge**

Touching electronic components can cause damage to or destroy the inverter through electrostatic discharge.

- Ground yourself before touching any component.

2.3 Information on Handling Batteries

This section contains safety information that must be observed at all times when working on or with batteries.

To prevent personal injury or property damage and to ensure long-term operation of the batteries, read this section carefully and observe all safety information at all times.

⚠ WARNING**Danger to life due to explosive gases**

Explosive gases may escape from the battery and cause an explosion. This can result in death or serious injury.

- Protect the battery environment from open flames, embers and sparks.
- Install, operate and maintain the battery in accordance with the manufacturer's specifications.
- Do not heat the battery above the temperature permitted or burn the battery.
- Ensure that the battery room is sufficiently ventilated.

⚠ WARNING**Chemical burns and poisoning due to battery electrolyte**

If handled inappropriately, battery electrolyte can cause irritation to the eyes, respiratory system and skin, and it can be toxic. This may result in blindness or serious chemical burns.

- Protect the battery enclosure against destruction.
- Do not open or deform the battery.
- Whenever working on the battery, wear suitable personal protective equipment such as rubber gloves, apron, rubber boots and goggles.
- Rinse acid splashes thoroughly for a long time with clear water, and consult a doctor.
- If acid fumes have been inhaled, consult a doctor.
- Install, operate, maintain and dispose of the battery according to the manufacturer's specifications.

⚠ WARNING**Danger to life due to incompatible lithium-ion battery**

An incompatible lithium-ion battery can lead to a fire or an explosion. With incompatible lithium-ion batteries, it is not ensured that battery management is intrinsically safe and will protect the battery.

- Verify that the battery complies with locally applicable standards and directives and is intrinsically safe.
- Ensure that the lithium-ion batteries are approved for use with the Sunny Island. The list of lithium-ion batteries approved for the Sunny Island is updated regularly (see the technical information "List of Approved Lithium-Ion Batteries" at www.SMA-Solar.com).
- If no lithium-ion batteries approved for the Sunny Island can be used, lead-acid batteries can be used.

⚠ WARNING**Risk of injury due to short-circuit currents**

Short-circuit currents in the battery can cause heat build-up and electric arcs. Burns or eye injuries due to flashes may result.

- Remove watches, rings and other metal objects.
- Use insulated tools.
- Do not place tools or metal parts on the battery.

⚠ CAUTION**Risk of burns due to hot battery components**

Improper battery connection may result in excessively high transition resistances. Excessive transition resistances give rise to localized heat build-up.

- Ensure that all pole connectors are connected with the connecting torque specified by the battery manufacturer.
- Ensure that all DC cables are connected with the connecting torque specified by the battery manufacturer.

NOTICE**Damage to the battery due to incorrect settings**

The set battery parameters influence the charging behavior of the Sunny Island inverter. The battery can be damaged by incorrect settings of the battery type, nominal voltage and capacity parameters.

- Ensure that the values recommended by the manufacturer are set for the battery (refer to the technical data of the battery in the manufacturer documentation). Note that the battery charging behavior names used by SMA Solar Technology AG and the battery manufacturer may, in some cases, differ in meaning (for the battery charging behavior of the Sunny Island inverter, see technical information "List of Approved Lithium-Ion Batteries").
- Set the battery capacity for a ten-hour electric discharge (C10). The battery manufacturer specifies the battery capacity in relation to discharge time.

NOTICE**Permanent damage to the battery due to improper handling**

Improper set-up and maintenance of the battery can cause it to become permanently damaged. Logs can help to determine the cause.

- Comply with all requirements of the battery manufacturer with regard to mounting location.
- Check and log the status of the battery before performing maintenance work.
Useful hint: Many battery manufacturers provide suitable logs.
 - Check the battery for visible damage and log.
 - Measure and log the fill level and acid density of FLA batteries.
 - In the case of lead-acid batteries, measure and log the voltages of the individual cells.
 - Perform and log the test routines required by the battery manufacturer.

i Prior damage to batteries

Batteries may have suffered prior damage due to production defects. Logs can help to determine the cause.

- Check and log the status of the battery before performing maintenance work.

i Check and log the status of the battery before performing maintenance work.

Transition resistances can impair the performance of the batteries.

- Ensure that the torques at the battery connections are correct each time that maintenance is performed.

3 Product Description

3.1 Sunny Island

The Sunny Island is a battery inverter that controls the electrical energy balance in an off-grid system, in a battery-backup system or in a system for increased self-consumption. In a battery-backup system, you can also use the Sunny Island for increased self-consumption.

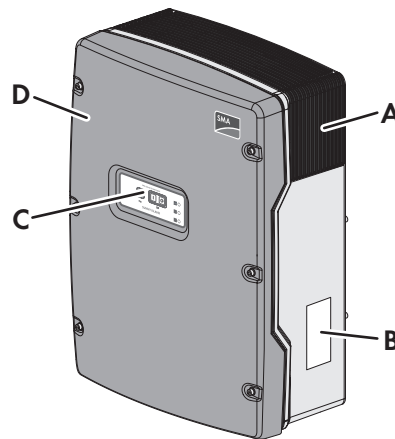

Figure 1: Design of the Sunny Island inverter

Position	Designation
A	Ventilation grid
B	Type label
C	Control panel
D	Enclosure lid

The Sunny Island supplies AC loads in the system from a battery or charges the battery with the energy provided by AC sources (e.g., PV inverter). AC sources supply loads and are used by the Sunny Island to recharge the battery. In order to be able to increase the availability of the off-grid system and reduce the battery capacity, the Sunny Island can use and control a generator as an energy reserve.

The loads may temporarily overload the Sunny Island. If there is a short circuit, the Sunny Island briefly feeds short-circuit currents into the utility grid. As a result, the Sunny Island may trip certain circuit breakers (for technical data see installation manual of the Sunny Island inverter).

Type label

The type label clearly identifies the product. The type label is located on the right-hand side of the enclosure (for a description of the type label, see the Sunny Island inverter operating manual).

You will require the information on the type label to use the product safely and when seeking customer support from Service (see Section 16 "Contact", page 161).

3.2 Control Panel of the Sunny Island Inverter

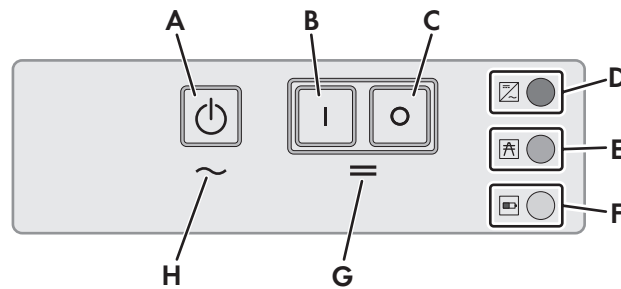

Figure 2: Layout of the control panel

Position	Symbol	Designation	Status	Explanation
A		Start-stop button TSS	–	By pressing the start-stop button, you can start or stop the system. In display messages on the Sunny Remote Control, the start-stop button is referred to as TSS .
B		"On" button	–	Pressing the "On" button will switch the Sunny Island on. The Sunny Island is in standby mode after being switched on.
C		"Off" button	–	Pressing the "Off" button will switch off the Sunny Island.
D		Inverter LED	Not glowing	The Sunny Island is switched off.
			Glowing green	The Sunny Island is in operation.
			Glowing orange	The Sunny Island is in standby mode.
			Glowing red	The Sunny Island switched off due to an error.
			Flashing quickly*	The Sunny Island is not configured.
			Flashing slowly**	The Sunny Island is in overnight shutdown.
E		Grid LED	Not glowing	There is no voltage present from the generator or the utility grid.
			Glowing green	Generator or utility grid is connected.
			Glowing orange	The Sunny Island is synchronizing the stand-alone grid with the generator or the utility grid.
			Glowing red	Error at the connection of the generator or the utility grid.
F		Battery LED	Glowing green	The state of charge is more than 50%.
			Glowing orange	The state of charge is between 50% and 20%.
			Glowing red	The state of charge is less than 20%.

Position	Symbol	Designation	Status	Explanation
G	≡	Standby	–	Position of the buttons for switching on and off
H	~	AC operation	–	Position of the button for starting and stopping operation

* Flashing at intervals of 0.5 s to 1 s

** Flashing at intervals of 1.5 s to 2 s







3.3 Type Label



The type label clearly identifies the product. The type label is located on the right-hand side of the enclosure. You will find the following information on the type label:

- Address of SMA Solar Technology AG
- Device type (Model)
- Serial number (Serial No.)
- Device-specific characteristics

You will require the information on the type label to use the product safely and when seeking customer support from Service (see Section 16 "Contact", page 161).

Symbols on the inverter, the ESS and the type label

Symbol	Explanation
	Danger to life due to electric shock The product operates at high voltages. All work on the product must be carried out by qualified persons only.
	Risk of burns due to hot surfaces The product can get hot during operation. Avoid contact during operation. Prior to performing any work on the product, allow the product to cool down sufficiently.
	Observe the documentation Observe all documentation supplied with the product.
~	Alternating current
---	Direct current
	Transformer The product has a transformer.
	WEEE designation Do not dispose of the product together with the household waste but in accordance with the disposal regulations for electronic waste applicable at the installation site.
	CE marking The product complies with the requirements of the applicable EU directives.
	Protection class I All electrical equipment is connected to the grounding conductor system of the product.

Symbol	Explanation
 IP54	Degree of protection IP54 The product is protected against interior dust deposits and splashing water from all angles.
	Certified safety The product is VDE-tested and complies with the requirements of the German Equipment and Product Safety Act.
	RCM (Regulatory Compliance Mark) The product complies with the requirements of the applicable Australian standards.

3.4 Sunny Remote Control

You can configure and control the system from a central location using the Sunny Remote Control display.

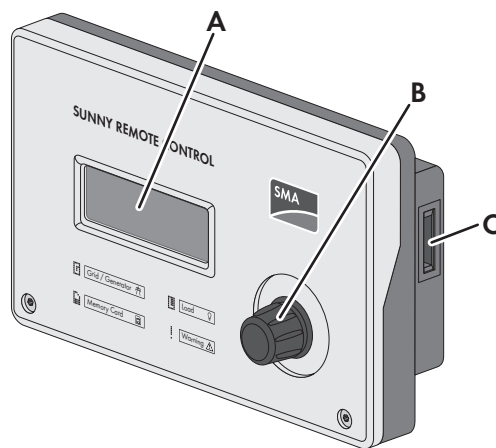

Figure 3: Layout of the Sunny Remote Control

Position	Designation	Explanation
A	Display	Four-line display shows operating data (e.g., operating state, display values) and events, warnings, or errors on the Sunny Island inverter. The display backlight is automatically deactivated after a short period of inactivity.
B	Switch	Pressing the button will turn on the backlight, confirm parameters, or switch the level within a menu. The return symbol "⌫" in the display indicates when you can perform an action by pressing the button. Turning the button will switch on the backlight, change parameters, or navigate within a menu level.
C	Slot for SD memory card	–

Service Interface, SD Memory Card

The Sunny Remote Control has a slot for SD memory cards. The SD memory card stores data for system control and facilitates service work. The SD memory card also allows you to update the firmware on the Sunny Island inverter. The following data is stored on the SD memory card:

- Parameter Settings
- Every minute, measurement data from the areas:
 - Battery
 - Sunny Island
 - Generator
 - Utility grid
 - Stand-alone grid
- Events and errors
- Statistical values of the battery

The SD memory card must be formatted as FAT-16 or FAT-32.

4 Starting and Stopping the System

4.1 Switching on the Sunny Island

Requirements:

- The load-break switch in the DC cable must be closed.
- The Sunny Island must not have switched itself off (see Section 10.7 "Charging the Battery After Automatic Shutdown in Off-Grid Systems (Emergency Charge Mode)", page 89).

Procedure:

- For systems with one Sunny Island, press the "On" button on the Sunny Island.

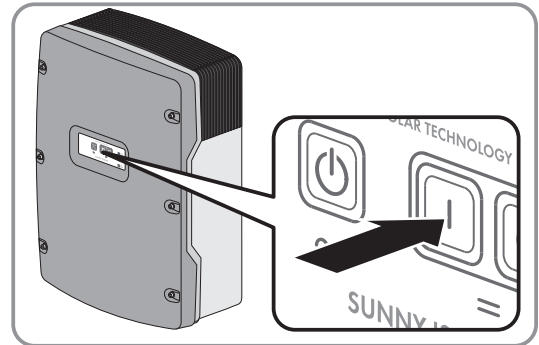

- For systems with up to three Sunny Island inverters, press and hold the "On" button on the master until an acoustic signal sounds.
- For multicluster systems, press and hold the "On" button on each master until an acoustic signal sounds.
 - The inverter LED on each Sunny Island inverter is glowing orange and the Sunny Island inverters are in standby mode.

4.2 Starting the System

Requirements:

- All Sunny Island inverters must be switched on.
- The circuit breakers for the AC sources in the stand-alone grid must be switched off in the AC distribution board.
- The load-break switch of the PV array must be open.
- The circuit breakers for the charge controllers must be switched off in the DC distribution board.

Procedure:

- Press the start-stop button on the Sunny Island and hold it until an acoustic signal sounds.
or
 Press and hold the button on the Sunny Remote Control until an acoustic signal sounds.
 - The inverter LED on each Sunny Island is glowing green.

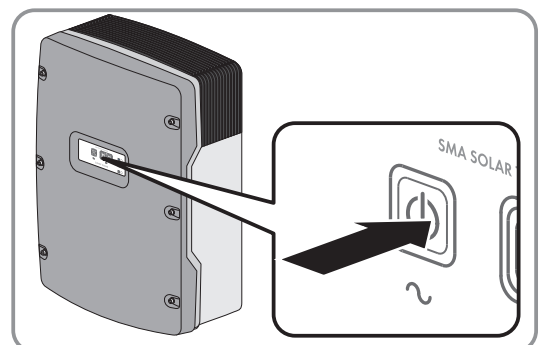

4.3 Stopping the System

If you stop the system, the Sunny Island switches from operation into standby mode. In standby mode, the Sunny Island discharges the battery due to its standby consumption. Tip: For longer shut-down periods, switch off the Sunny Island (see Section 4.4, page 21).

Procedure:

- Press and hold the start-stop button on the Sunny Island until the inverter LED is glowing orange.
- **or**
- Press and hold the button on the Sunny Remote Control until the progress bar has run down.
 - ☑ The inverter LED on each Sunny Island is glowing orange. The Sunny Island inverters are in standby mode.

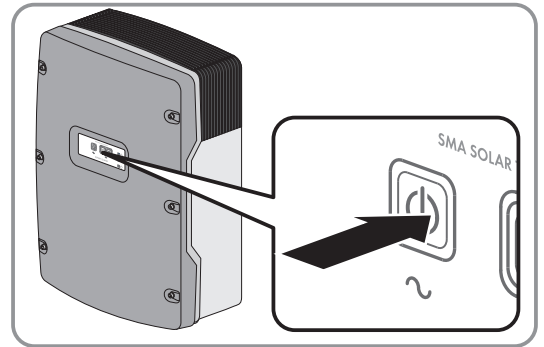

4.4 Switching Off the Sunny Island

Requirements:

- ☐ The system is stopped.

Procedure:

- Press and hold the "Off" button on the Sunny Island until an acoustic signal sounds.
 - ☑ The inverter LED is off on all Sunny Island inverters.

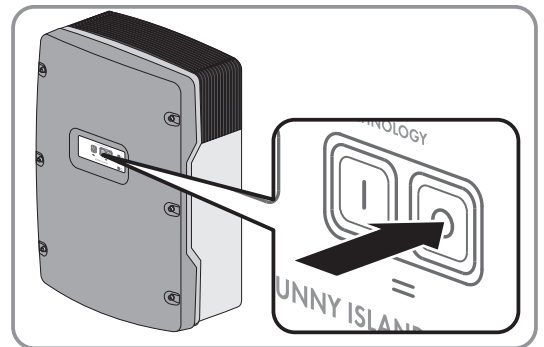

4.5 Tripping the Emergency Disconnection of the System

i Effects of an emergency disconnection

Emergency disconnection triggers the uncontrolled shutdown of the system and unsaved data is lost.

- Only use the emergency disconnection to avoid danger or consequential damage.
- In the event of an emergency disconnection in a multicluster system, always check whether any fuse elements in the Multicluster-Box, such as circuit breakers, have tripped. If any fuse elements have tripped, reactivate these fuse elements.

Procedure:

- Press and hold the "Off" button on the Sunny Island until an acoustic signal sounds.
 - ☑ The inverter LED is off on all Sunny Island inverters.

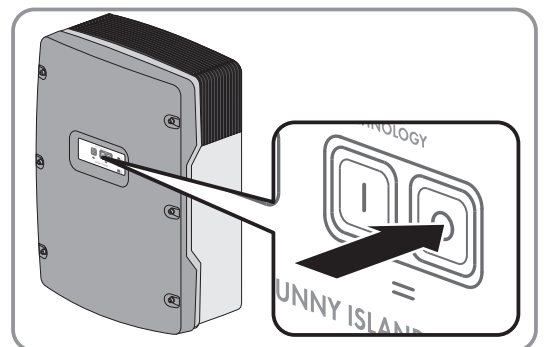

4.6 Setting Time-Controlled Inverter Operation in Off-Grid Systems

Example: Parameter settings for time-controlled inverter operation

You want to operate the Sunny Island in inverter operation every Sunday from 10:00 a.m. to 6:00 p.m., starting on Sunday, January 8, 2012. To do this, set the Sunny Island as follows:

- Str.Date: 08.01.2012
- Start Time: 10:00:00
- Run Time: 08:00:00
- Repetition: Weekly

Procedure:

1. Log in to the communication product as User (see user manual of the communication product) or switch to user mode on the Sunny Remote Control (see Section 5.3, page 29).

```
Inverter (1/1) ↵
Tot.Power xx:x kW
Timer Mode Disable
```

2. To set the time-controlled inverter operation on the Sunny Remote Control, select the Inverter display page on the Sunny Remote Control and press the button.

```
Inverter (1/2)
Restart --- ↵
Str.Date xx:xx.xxxx
Start Time xx:xx:xx
```

The Sunny Remote Control switches to the **Inverter** setting page.

3. Set the time-controlled inverter operation:

- Select the **Start date for time-controlled inverter operation / Start Date** parameter and set it to the desired start date.
- Select the **Start date for time-controlled inverter operation / Str.Date** parameter and set it to the desired start time.
- Select the **Start date for time-controlled inverter operation / Str.Date** parameter and set it to the desired running time.
- Select the **Repetition cycle for time-controlled inverter operation / Repetition** parameter and set it to the desired repetition cycle.

4. To activate time-controlled inverter operation, select the **Time controlled inverter operation / Timed Start** parameter and set it to **Enable**.

Time-controlled inverter operation is activated. If the Sunny Island has started automatically under time-control and you stop the Sunny Island, time-controlled inverter operation is deactivated automatically.

5 Operation of the Sunny Island Inverter with the Sunny Remote Control

5.1 Display Modes

The Sunny Remote Control uses four display modes for the display. The Sunny Remote Control will switch to standard mode if the button has not been used for over five minutes.

State	Page contents
Standard mode <home>	<ul style="list-style-type: none"> • Message regarding operating states • Display of energy flows • Display of key parameters <p>In display messages on the Sunny Remote Control, <home> refers to the standard mode.</p>
User mode User	<ul style="list-style-type: none"> • Display of and access to key operating parameters <p>In display messages on the Sunny Remote Control, User refers to the user mode.</p>
Installer mode Installer	<ul style="list-style-type: none"> • Display of and access to configuration and operation parameters <p>The installer mode is protected with an installer password. In display messages on the Sunny Remote Control, Installer refers to the installer mode.</p>
Expert mode Expert	<ul style="list-style-type: none"> • Display of and access to all parameters for the system configuration set in QCG <p>The expert mode can be accessed only via installer mode (see Section 5.4.1, page 32). In display messages on the Sunny Remote Control, Expert refers to the expert mode.</p>

The parameters for devices that are not configured are hidden, e.g., the generator parameters are hidden for systems without a generator. The parameters for multicluster systems are available only in expert mode.

5.2 Standard Mode

5.2.1 Display of Operating States

The Sunny Remote Control displays the following operating states until the Sunny Island is started.

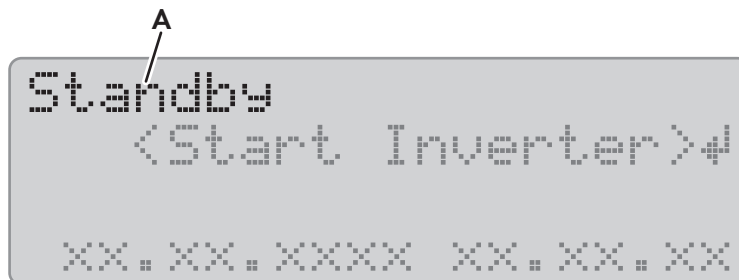

Figure 4: Display of operating states (example: Standby)

Position	Designation	Explanation
A	Boot	The Sunny Island is initializing.
	Error	The Sunny Island is in error status.
	LBM 1	The Sunny Island is in battery protection mode 1.
	LBM 2	The Sunny Island is in battery protection mode 2.
	LBM 3	The Sunny Island is in battery protection mode 3.
	Restart	The Sunny Island is performing a restart.
	Shutdown	The Sunny Island is stopped.
	Silent	The Sunny Island is in energy-saving mode.
	Standby	The Sunny Island is in standby mode or in time-controlled operation.
	Startup	The Sunny Island is starting up.

5.2.2 Information Page in Systems for Increased Self-Consumption and Battery Backup Systems

When the Sunny Island is started, the Sunny Remote Control provides information on the status of the system for increased self-consumption.

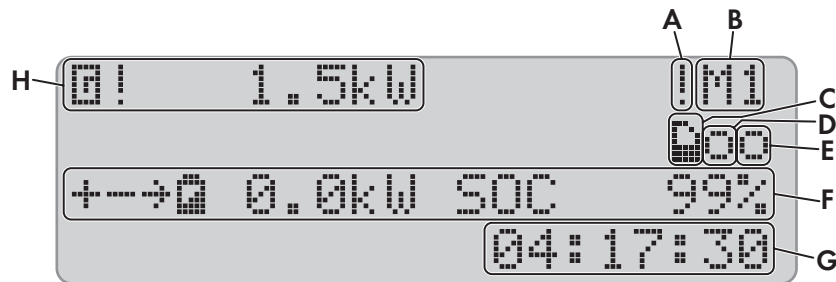

Figure 5: Energy flows and status messages of the Sunny Island

Position	Symbol	Designation	Explanation
A	!	Warning symbol	Symbol for warnings and errors that do not affect the Sunny Island operation. If this symbol is flashing, acknowledge the error or warning (see Section 10.3, page 47).
B	M1	Device assignment	The Sunny Island connected to the Sunny Remote Control is the master.
	S1		The Sunny Island connected to the Sunny Remote Control is slave 1.
	S2		The Sunny Island connected to the Sunny Remote Control is slave 2.
C	SD Memory Card icon	SD Memory Card	SD memory card is inserted.
	Symbol flashing		The Sunny Island is accessing the SD memory card.
	None Symbol		SD memory card not inserted.
D	Relay 1 Deactivated icon	Multifunction relay 1	Multifunction relay 1 is deactivated.
	Relay 1 Activated icon		Multifunction relay 1 is activated.
E	Relay 2 Deactivated icon	Multifunction relay 2	Multifunction relay 2 is deactivated.
	Relay 2 Activated icon		Multifunction relay 2 is activated.
F	Battery Charging icon	Battery power and state of charge*	The battery is being charged.
	Battery Discharging icon		The battery is being discharged.
	Battery Power icon		Battery power in kW, state of charge (SOC) in %
G	hh:mm:ss	Time	System time

Position	Symbol	Designation	Explanation
H		Power and status of the utility grid*	Power in kW
			The utility grid voltage and frequency are within the configured limits.
			The maximum reverse power in the utility grid has been exceeded.

* If a PV production meter is installed, load power and PV production are additionally shown in kW on the left side of the display. Load power is marked with **L** and PV production with **P**.

5.2.3 Information Page in Off-Grid Systems

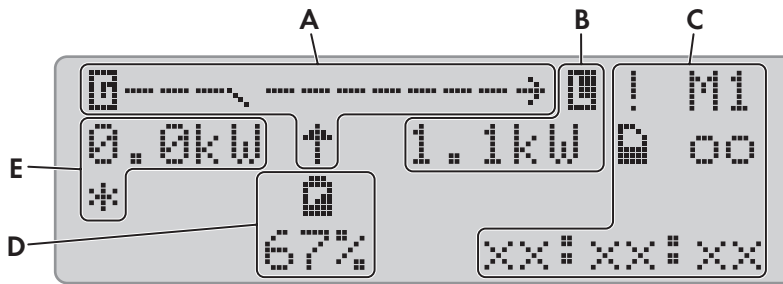

Figure 6: Energy flows and status of the Sunny Island inverter (example)

Position	Designation
A	Graphical Representation of the Energy Flows
B	Status of the stand-alone grid
C	Status of the Sunny Island Inverter
D	State of charge of the battery
E	Status of the generator

Graphical Representation of the Energy Flows

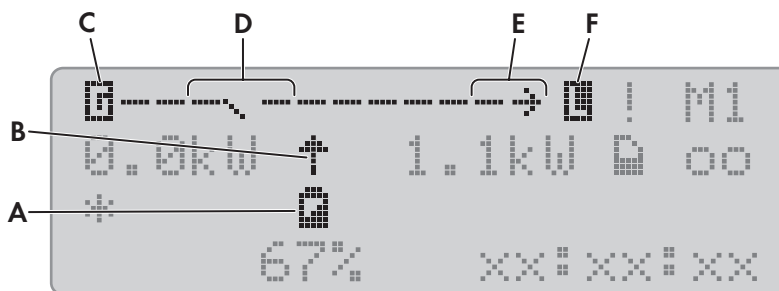

Figure 7: Energy flow diagram in standard mode (example)

Position	Symbol	Designation	Explanation
A		Battery	Battery symbol If this symbol is flashing, acknowledge the error or warning
B		Direction of energy flow	The battery is supplying the loads.
			The battery is being charged.
C		Generator	Generator symbol



Position	Symbol	Designation	Explanation
D		Internal transfer relay	The generator is disconnected from the stand-alone grid.
			The stand-alone grid is synchronized with the generator. The generator is supplying the loads and charging the battery.
E		Direction of energy flow	Loads are being supplied.
			AC sources in the stand-alone grid are supplying more energy than is being consumed by the stand-alone grid.
F		Loads in the Stand-alone grid	Symbol for loads in the stand-alone grid

Status of the Sunny Island Inverter



Figure 8: Status of the Sunny Island inverter (example)

Position	Symbol	Designation	Explanation
A	!	Warning symbol	Symbol for warnings and errors that do not affect the Sunny Island operation. If this symbol is flashing, acknowledge the error or warning (see Section 10.3, page 47).
B	M1	Device assignment	The Sunny Island connected to the Sunny Remote Control is the master.
	S1		The Sunny Island connected to the Sunny Remote Control is slave 1.
	S2		The Sunny Island connected to the Sunny Remote Control is slave 2.
C		SD Memory Card	SD memory card is inserted.
	Symbol flashing		The Sunny Island is accessing the SD memory card.
	None Symbol		SD memory card not inserted.
D		Multifunction relay 1	Multifunction relay 1 is deactivated.
			Multifunction relay 1 is activated.

Position	Symbol	Designation	Explanation
E		Multifunction relay 2	Multifunction relay 2 is deactivated.
			Multifunction relay 2 is activated.
G	hh:mm:ss	Time	System time

Battery state of charge

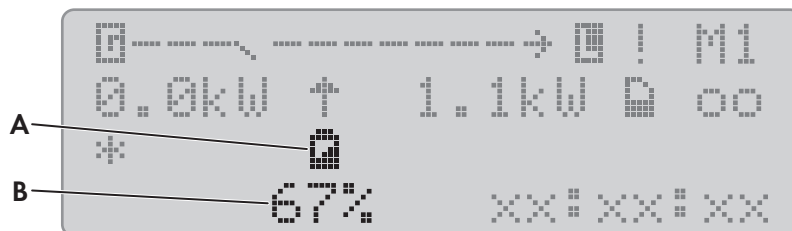

Figure 9: State of charge of the battery in standard mode (example)

Position	Designation	Explanation
A	Battery	Battery symbol
B	State of charge	State of charge of the battery in percent

Status of the External Energy Source



Figure 10: Status of the external energy source in standard mode (example)

Position	Symbol	Designation	Explanation
A	☼	Status of the generator	Voltage and frequency of the generator are within the thresholds set.
	!		The maximum reverse power in the generator has been exceeded.
	B		Battery Electricity generator was requested due to state of charge.
	C		Cycle Generator was requested via time control.
	E		External Generator was requested by an extension cluster.
	L		Load Electricity generator was requested due to load.
	S		Start You have manually started the generator via Sunny Remote Control or a generator was requested via the DigIn input.
	T		Time You have started the generator for one hour via Sunny Remote Control.
B	—	Power of the generator or the utility grid	Power in kW
C	☼	Generator	Generator symbol
D	↘	Internal transfer relay	The generator is disconnected from the stand-alone grid.
		The stand-alone grid is synchronized with the generator. The generator is supplying the loads and charging the battery.

5.3 User Mode

5.3.1 Pages in the User Mode

User mode displays all important information for the system sorted by category. User mode enables manual control of the Sunny Island inverter or system devices, e.g., generator start.

User mode distinguishes between display pages and setting pages. Display pages show the parameters of a category. Setting pages enable the operation and setting of the system.

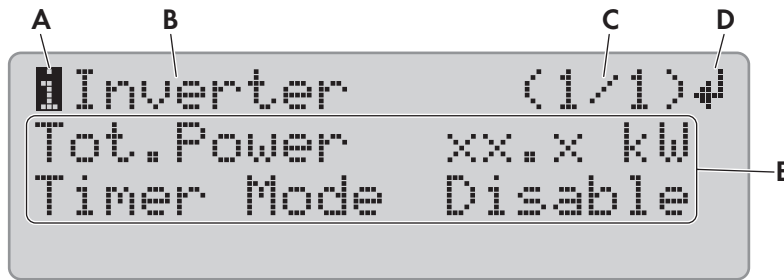

Figure 11: Layout of a page in user mode (example)

Position	Designation	Symbol or message	Explanation
A	Page type		Information This symbol indicates display pages.
			Set This symbol indicates setting pages.
B	Category	–	Category name (see Section 13.1 "Directory of the Parameters in User Mode", page 102)
C	Page and number of pages	–	Page and number of pages of the selected category
D	Return symbol		On display pages, this symbol means that setting pages are available for this category. On setting pages, this symbol points to the selected parameter.
		no symbol	No setting pages are available for this category.
		–	Parameters with the current values
E	Parameter	–	Parameters with the current values

5.3.2 Displaying Parameters and Operating and Setting the System

1. Press the button to activate the display illumination of the Sunny Remote Control.
2. Turn the button to the right.

- The Sunny Remote Control switches from standard mode to user mode.

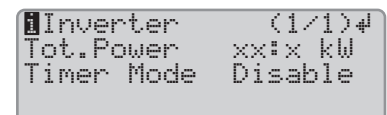

3. To scroll through the display pages, turn the button to the right or left.
4. To select a setting page, scroll to the display page for the category of the desired setting (see Section 13.1 "Directory of the Parameters in User Mode", page 102).

Example: Selecting the Display Page.

You want to select the category **Inverter**.

- Select the **Inverter (1/1)** display page.

5. Press the button. The Sunny Remote Control displays the setting pages belonging to the display page.

Example: Selecting the Setting Page

You have selected the display page **Inverter (1/1)**.

- Press the button.

```
Inverter      (1/1)
Tot.Power    xx!x kW
Timer Mode   Disable
```

- The setting page **Inverter (1/2)** appears.

```
Inverter      (1/2)
Restart      ---
Str.Date     xx!xx.xxxx
Start Time   xx!xx!xx
```

6. To select the desired parameter, turn the button to the right until the return symbol appears to the right of the desired parameter.

- You have selected the parameter.

7. To set the parameter, press the button and then turn it to the left or right.

8. Once you have set the required parameter, press the button. This saves the setting.

Example: The Sunny Island is to start in time-controlled operation weekly. For this, the repetition type (Repetition) must be set to (Weekly).

- Access the setting page **Inverter (1/2)**.

```
Inverter      (1/2)
Restart      ---
Str.Date     xx!xx.xxxx
Start Time   xx!xx!xx
```

- Turn the button until the return symbol \leftarrow appears next to the parameter **Repetition**. The Sunny Remote Control switches from setting page **Inverter (1/2)** to setting page **Inverter (2/2)**.
- Press the button.
- Turn the button to the right until **Weekly** appears.
- Press the button. This saves the parameter.
- You have set the repetition type to Weekly in time-controlled inverter operation.

```
Inverter      (2/2)
Run Time     xx.xx.xxxx
Repetition   Weekly
Timed Start  Disable
```

9. To exit the setting page, switch to the display page or the standard mode:

Useful hint: **<back>** and **<home>** also appear at the end of the list if the button is turned to the right.

- Turn the button to the left until the return symbol appears in the first line.
- To return to the display page, turn the button to the left until **<back>** appears.
- To switch to standard mode, turn the button to the left until **<home>** appears.
- Press the button.

<back> and **<home>** also appear at the end of the list if the button is turned to the right.

5.4 Installer Mode and Expert Mode

5.4.1 Switching to Installer Mode or Expert Mode

The installer mode is protected with an installer password. The installer password changes constantly and must be recalculated every time. Expert mode can be accessed only via installer mode.

NOTICE

System failures due to entry of incorrect parameter values

The system can become unstable and fail due to entry of incorrect parameter values. All parameters that could affect the operational safety of the system are protected by the installer password.

- Only a qualified person is permitted to set and adjust system parameters.
- Give the installer password only to qualified persons and operators.

Procedure:

1. On the Sunny Remote Control, select the setting page **Password (1/1)** in user mode.
2. Calculate the checksum of the operating hours **Runtime**. This determines the installer password.

Example: Calculating the checksum

The operating hours **Runtime** are 1234 h. The checksum is the sum of all digits:

$$1 + 2 + 3 + 4 = 10$$

The checksum is 10.

3. Select the parameter **Set** and set the installer password calculated.

```
Installer
100# Meters
200# Settings
300# Diagnosis
```

- The Sunny Remote Control is in installer mode.

4. To switch to expert mode, select the parameter **700.01 ActLev** and set to **Expert** (see Section 5.4.6, page 34).

5.4.2 Exiting Installer Mode or Expert Mode

If you do not press or turn the button on the Sunny Remote Control for five minutes, the Sunny Remote Control will switch from installer or expert mode to standard mode automatically.

Procedure:

- Select the parameter **700.01 ActLev** on the Sunny Remote Control and set to **User** (see Section 5.4.6, page 34).

5.4.3 Menus in Installer and Expert Mode

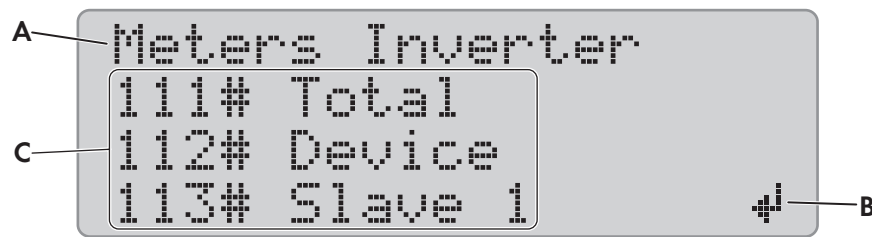

Figure 12: Layout of the menu page in installer mode (example)

Position	Designation	Explanation
A	Menu path	The two previously selected menu levels If you are in the top menu level, the display will show Installer in installer mode and Expert in expert mode.
B	Return symbol	Return symbol for selecting a menu
C	Menu	–

5.4.4 Parameter Page in Installer and Expert Mode

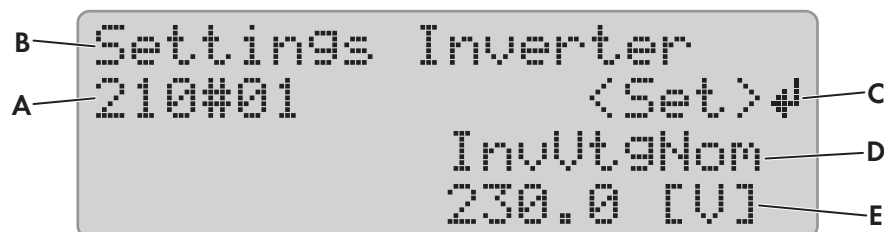

Figure 13: Layout of the parameter page in installer mode (example)

Position	Designation	Explanation
A	Menu number and parameter number	–
B	Menu path	The two previously selected menu levels
C	Return symbol	Return symbol for setting the parameter If no return symbol is displayed, the parameter cannot be set.
D	Name of the parameter	–
E	Value and unit of the parameter	–

5.4.5 Selecting Menus and Parameters

1. Switch to installer mode on the Sunny Remote Control (see Section 5.4.1, page 32).
2. Turn the button to the right until the return symbol appears to the right of the desired menu. The Sunny Remote Control scrolls through the menu items on the display line by line.

3. Press the button.

- The Sunny Remote Control displays the sub-menu level. The selected menu level is shown in the first line.

4. Repeat steps 2 and 3 until the Sunny Remote Control displays the first parameter page.

5. Turn the button to the right until the Sunny Remote Control displays the desired parameter.

6. Set the parameter (see Section 5.4.6, page 34).

7. To exit the parameter page, switch to the higher level or switch to standard mode:

Useful hint: **<back>** and **<home>** also appear at the end of the list if the button is turned to the right.

- Turn the button to the left until the return symbol appears in the first line.
- To switch to a higher menu level, turn the button to the left until **<back>** appears.
- To switch to standard mode, turn the button to the left until **<home>** appears.
- Press the button.

<back> and **<home>** also appear at the end of the list if the button is turned to the right.

5.4.6 Setting Parameters

1. Switch to installer mode on the Sunny Remote Control (see Section 5.4.1, page 32).

2. Select the desired parameter. You can set only the parameters for which **< Set >** [#] is shown in the second line in the display.

```
Settings interter
210#01          (Set)#
                InvUt9Nom
                250.0 [V]
```

3. Press the button.

- The return symbol is flashing next to the value.

✘ Stop device to change the value appears in the display?

The parameter can be changed only in standby mode.

- Stop the system (see Section 4.3, page 20).

✘ No permission to change the value appears in the display?

You are not allowed to change the parameter in installer mode.

- If you want to change the parameters for the battery, select the menu New Battery in the QCG (see Section 11.8 "Replacing the Battery", page 97).
- For all other settings, select the menu **New System** in the QCG (see the Sunny Island inverter installation manual).

4. To set the parameter, turn the button to the left or right.

5. Press the button.

- The Sunny Remote Control requests confirmation of the set parameter.

```
Settings interter
210#01 (accept Y/N)#
                InvUt9Nom
                230.0 [V]
```

6. To confirm the value, turn the button to the right until **Y** is flashing and then press the button.

7. To discard the value, turn the button to the right until **N** is flashing and then press the button.

5.4.7 Directly Accessing the Parameters

Any parameter can be accessed directly by entering a five-digit number. The five-digit number is composed as follows:

- The first three digits are the menu number.
- The last two digits are the parameter number.

Example: Five-digit number for direct parameter access.

The parameter **111.01 TotInvPwrAt** allows you to display the complete active power of the Sunny Island inverters in a cluster. The five-digit number for direct access is 11101.

Procedure:

1. Switch to installer mode on the Sunny Remote Control (see Section 5.4.1, page 32).
2. Select the parameter **600.02 Select Number** and set the five-digit number.
 - The parameter is displayed.
 - The display shows **Item not Found?**
 - You are still in the installer mode or entered the wrong number.
 - Switch to expert mode (see Section 5.4.1, page 32) or repeat the entry.

6 Operation of the Sunny Island Inverter with a Communication Product

When operating a Sunny Island inverter with a communication product, observe the following differences compared with operation via Sunny Remote Control:

- When the parameters and messages of the Sunny Island inverter are accessed via the communication product, the defined access rights of the communication product apply (see user manual of the communication product).
- The inverter messages are displayed on the screen of the communication product as clear-text names (see technical information "SUNNY ISLAND – Message of the same event for Speedwire (e. g. Sunny Explorer) and RS485 / Sunny Remote Control").

Example:

The Sunny Remote Control displays the following message when the Sunny Island inverter is warning of high operating temperatures: **W212 BatTmpHiWarn**.

The same warning message appears as clear text on the screen of the communication product:

Overtemperature fault in battery.

- The inverter parameters are displayed on the screen of the communication product as clear-text names (see technical information "SUNNY ISLAND – Comparison of the same parameters for Speedwire (e. g. Sunny Explorer) and RS485 / Sunny Remote Control").

Example:

Example: The information regarding the reason for the generator request sent by the Sunny Island is displayed on the screen of the Sunny Remote Control as parameter number and parameter name: **133.01 GnDmdSrc**.

The same information appears as clear text on the screen of the communication product: **Reason for requesting generator**.

- A three-phase cluster is shown as a three-phase inverter on the screen of the communication product.

Function of the Sunny Island inverter in a three-phase cluster	Display on the communication product (example)
Master	Line conductor 1
Slave 1	Line conductor 2
Slave 2	Line conductor 3

- The parameters at the Sunny Remote Control can be adjusted only one at a time. The communication product allows associated parameters to be grouped. To edit the parameters, this group must be selected on the communication product.

Example:

The battery states of charge for the battery protection mode are set via three parameters on the Sunny Remote Control:

- **223.05 BatPro1Soc**: State of charge for battery protection mode, level 1
 - **223.06 BatPro2Soc**: State of charge for battery protection mode, level 2
 - **223.07 BatPro3Soc**: State of charge for battery protection mode, level 3
-

On the communication product, all three battery states of charge can be set via the parameter **Battery state of charge for protection mode**.

7 Data Storage and Firmware Update

7.1 Data Storage on the Computer

With Sunny Explorer, you can save system yields and events as CSV files on your computer (see user manual of Sunny Explorer). The CSV files can be opened in Microsoft Excel and the data can be used e.g. to create diagrams.

7.2 Data Storage on SD Memory Card

7.2.1 Insert the SD Memory Card

Requirements:

- The SD memory card must be formatted as FAT-16 or FAT-32.
- The SD memory card must be used exclusively as a data medium for the system.

Procedure:

- Insert the SD memory card, with the slanted corner facing upwards, into the SD memory card slot in the Sunny Remote Control.

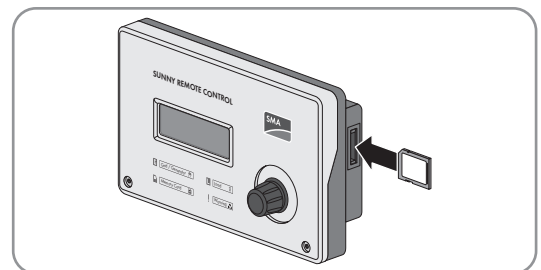

7.2.2 Loading and Saving Parameters

You can load and save the current parameter settings in two different parameter sets on the SD memory card. The Sunny Remote Control calls the two parameter sets **Set1** and **Set2**. Each parameter set saves all settings. This makes it possible to test the settings of a new parameter set without having to delete the old parameter set.

Useful hint: As soon as you have adjusted the system to your requirements, save the parameter settings to the SD memory card. After saving, you can make further adjustments to the system. If the adjustment does not lead to the desired results, reload the saved parameter set.

Requirement:

- The SD memory card must be inserted.

Procedure:

1. Switch to installer mode on the Sunny Remote Control (see Section 5.4.1, page 32).
2. To save a parameter set, select the parameter **550.01 ParaSto** and set the parameter:

Value	Explanation
Set1	Save the settings in the first parameter set.
Set2	Save the settings in the second parameter set.

3. Proceed as follows to load a parameter set:

- Switch to expert mode on the Sunny Remote Control (see Section 5.4.1, page 32).
- Select the parameter **550.02 ParaLod** and set the parameter:

Value	Explanation
Set1	Save the settings in the first parameter set.

Value	Explanation
Set2	Save the settings in the second parameter set.
Factory	Start the quick configuration guide.

7.2.3 Saving the Event History and Error History

Requirement:

- The SD memory card must be inserted.

Procedure:

1. Switch to installer mode on the Sunny Remote Control (see Section 5.4.1, page 32).
2. To save the event history, select the parameter **550.03 CardFunc** and set to **StoEvtHis**.
3. To save the error history, select the parameter **550.03 CardFunc** and set to **StoFailHis**.
4. To save the error history and the event history, select the parameter **550.03 CardFunc** and set to **StoHis**.

7.2.4 Displaying the SD Memory Card Status Message

The Sunny Remote Control determines the SD memory card status (see Section 13.2.3.1 "Inverter (310#)", page 149).

Procedure:

1. Switch to installer mode on the Sunny Remote Control (see Section 5.4.1, page 32).
2. Select the parameter **312.11 CardStt** and read off the value.

7.2.5 Removing the SD Memory Card

If the SD memory card is removed without preparation, the removal will cause data loss. Data loss affects the log data of the last 15 minutes at most.

Procedure:

1. Switch to installer mode on the Sunny Remote Control (see Section 5.4.1, page 32).
2. Select the parameter **550.03 CardFunc** and set to **ForcedWrite**. Unsaved data will now be saved to the SD memory card.
3. Remove the SD memory card.

7.2.6 Displaying the SD Memory Card Content

The files saved to the SD memory card depend on the configuration and on the system.

 BATSTAT		File Folder
 HISTORY		File Folder
 LOGGING		File Folder
 MISC		File Folder
 SIPAR		File Folder
 SIM.CCF	1 KB	CCF-Datei
 UPDATE.BIN	1.420 KB	BIN-Datei
 version.txt	1 KB	Textdokument

Figure 14: Content of an SD memory card (example)

Explanation of the folders:

Folder name	Explanation
BATSTAT	Folder containing battery statistics for each month The files are stored by year and month in sub-folders.
HISTORY	Folder containing event and error histories
LOGGING	Folder containing the data logging, event and error histories for each day The files are stored by year and month in sub-folders.
SIPAR	Folder containing the parameter lists

Explanation of the files within the folders:

File name	Explanation
evthis.log	Event history
errhis.log	Error history
si010112.evt	Event and error histories for one day The date (ddmmyy) is part of the file name.
si010112.log	Data logging for the day The date (ddmmyy) is part of the file name.
sipar.lst	Current parameter set
sipar1.lst	Parameter set 1
sipar2.lst	Parameter set 2
update.bin	Sunny Island inverter firmware
batstat.txt	Statistical values of the battery These values are saved every night at 10:00 p.m.
batstat.sma	Statistical values of the battery for evaluation by SMA Solar Technology AG
sim.ccf	System information of the Sunny Island inverter
bootex.log	File generated by the operating system of the computer This file is not generated by every operating system.

Structure of the files:

The files are CSV files, which means that the data is saved as ASCII text. The files are structured as follows:

- The first lines in the file are used for information. Information lines start and end with the character #.
- The data in the following lines is separated by semicolons.
- Decimal places are separated by periods.
- The date format is dd.mm.yyyy.
- The time format is hh:mm:ss.
- Some of the parameter values are saved with plain text numbers (see Section 13.2 "Directory of the Parameters in Installer Mode and Expert Mode", page 108).

Requirements:

- A computer with spreadsheet software installed must be available.
- The spreadsheet software must be able to read CSV files.

Procedure:

1. Insert the SD memory card into the card reader and display the content.
2. Start the spreadsheet software and import the required file. When importing, set the import filter in accordance with the file structure (see spreadsheet software manual).

7.3 Firmware Update

7.3.1 Display of the Firmware Version

The current firmware version of the Sunny Island and the SMA Speedwire data module Sunny Island can be downloaded as a software package at www.SMA-Solar.com. The software package contains the following components that are displayed differently on the screen of the Sunny Remote Control and communication product.

Hardware component	Display of the firmware components on the Sunny Remote Control	Display of the firmware components on the communication product (e.g. Sunny Explorer)
Sunny Island	Master (Operation Control Unit)	Main processor
	Digital signal processor	Logic component
SMA Speedwire data module for Sunny Island	-	Protocol converter

The version number of the software package is based on the first two digits of the version number of the operation control unit.

Example

The version number of the operation control unit is, for example, **3.113**. The first two digits are therefore **3** and **1**. The version number of the software package is as follows: **03.01.00.R**

7.3.2 Updating the Firmware Using an SD Memory Card

Automatic Sunny Island inverter start

If the Sunny Island was in operation before the firmware update, the Sunny Island restarts automatically upon completion of the firmware update.

Requirements:

- The SD memory card must be formatted as FAT-16 or FAT-32.
- SD memory card with the current firmware in the main directory must be available.
- The SD memory card must be used exclusively as a data medium for the system.
- A computer must be able to read from and write to the SD memory card.
- The Sunny Remote Control must be connected to the master.

Procedure:

1. Insert the SD memory card into the SD memory card slot (see Section 7.2.1, page 37).
2. Wait until the message **UPDATE AVAILABLE** appears. This can take up to two minutes.
3. Confirm the question **UPDATE AVAILABLE Start update now ?** with **YES**.
 - The Sunny Island switches to standby and updates the firmware.

7.3.3 Updating the Firmware Using Sunny Explorer

i Automatic Sunny Island inverter start

If the Sunny Island was in operation before the firmware update, the Sunny Island restarts automatically upon completion of the firmware update.

Using Sunny Explorer, transfer the firmware update to the SMA Speedwire data module Sunny Island. Then, the SMA Speedwire data module Sunny Island automatically transfers the firmware update to the SD memory card in the Sunny Remote Control. This transfer takes some time.

Requirements:

- The SMA Speedwire data module Sunny Island of the type SWDMSI-NR10 with firmware version 1.01.06.R or higher must be installed in the system.
- A computer with Sunny Explorer and the current firmware must be available.
- The Sunny Remote Control must be connected to the master.

Procedure:

1. Ensure that a writable SD memory card is inserted in the Sunny Remote Control and remains inserted throughout the entire update.
 2. Switch to installer mode on the Sunny Remote Control (see Section 5.4.1, page 32).
 3. Set the parameter **250.32 UpdMode** to **Auto**.
 4. Set the parameter **250.33 UpdAutoTime** to the desired firmware update time.
 5. Transfer the firmware update from the computer to the Sunny Island using Sunny Explorer (see the Sunny Explorer user manual).
 6. Once the transfer is complete, close Sunny Explorer.
- Once the transfer to the SD memory card is complete, the Sunny Island updates automatically at the specified time. The Sunny Island switches to standby mode and updates the firmware.

7.3.4 Performing a Remote Update Using the Sunny Home Manager

i Automatic Sunny Island inverter start

If the Sunny Island was in operation before the firmware update, the Sunny Island restarts automatically upon completion of the firmware update.

The Sunny Home Manager can automatically make the current firmware available via Sunny Portal. For this, the Sunny Home Manager first transfers the firmware update to the SMA Speedwire data module Sunny Island. Then, the SMA Speedwire data module Sunny Island automatically transfers the firmware update to the SD memory card in the Sunny Remote Control. This transfer takes some time.

Requirements:

- The Sunny Island must be registered in Sunny Portal.
- The SMA Speedwire data module Sunny Island of the type SWDMSI-NR10 must be installed in the system.
- The Sunny Home Manager must be integrated in the system.
- The Sunny Remote Control must be connected to the master.

Procedure:

1. Ensure that a writable SD memory card is inserted in the Sunny Remote Control and remains inserted.
 2. Switch to installer mode on the Sunny Remote Control (see Section 5.4.1, page 32).
 3. Set the parameter **250.32 UpdMode** to **Auto**.
 4. Set the parameter **250.33 UpdAutoTime** to the desired firmware update time.
 5. Activate the automatic software update in the Sunny Home Manager (see user manual of the Sunny Home Manager).
- Once the transfer to the SD memory card is complete, the Sunny Island updates automatically at the specified time. The Sunny Island switches to standby mode and updates the firmware.

8 Manually Controlling the Generator

8.1 Starting the Generator with Sunny Remote Control

Requirements:

- The Sunny Island must be able to control the generator via a control cable.
- The Sunny Remote Control must be in standard mode or user mode.

Procedure:

1. Select the **Generator** display page on the Sunny Remote Control and press the button (see Section 5.3.2 "Displaying Parameters and Operating and Setting the System", page 30).
2. To start the generator and run it permanently, select the parameter **Mode** and set to **Start**.
 - The electricity generator starts and runs until you stop it again.
3. To start the generator and run it for one hour, select the parameter **Mode** and set to **Run1h**.
 - The generator starts. If there is no generator request after one hour, the Sunny Island stops the generator.

8.2 Stopping the Generator with Sunny Remote Control

WARNING

Risk of crushing injuries due to moving PV array parts

Moving parts in the PV array can crush or sever body parts. A generator can be started automatically by the Sunny Island.

- Operate the generator only with the safety equipment.
- Carry out work on the generator in accordance with the manufacturer's specifications.

Requirements:

- The Sunny Island must be able to control the generator via a control cable.
- The Sunny Remote Control must be in standard mode or user mode.

Procedure:

1. Select the **Generator** display page on the Sunny Remote Control and press the button (see Section 5.3.2 "Displaying Parameters and Operating and Setting the System", page 30).
2. Select the parameter **Mode** and set to **Stop**.
 - The generator is stopped temporarily. The generator restarts when a generator request is issued in automatic generator mode and the minimum stop time has elapsed.
3. To stop the generator permanently, deactivate the automatic generator mode:
 - Switch to installer mode on the Sunny Remote Control (see Section 5.4.1, page 32).
 - Select the parameter **235.01 GnAutoEna** and set to **Disable**.
 - The generator is permanently stopped.

8.3 Starting the Generator without Autostart Function

1. Start the generator (see manufacturer's manual).
2. Close the load-break switch between the generator and Sunny Island.
- After the warm-up period, the Sunny Island connects the stand-alone grid to the generator.

8.4 Stopping the Generator without Autostart Function

1. Stop the generator on the Sunny Remote Control (see Section 8.2, page 43). When you do this, the Sunny Island disconnects the stand-alone grid from the generator.
2. Open the load-break switch between the generator and the Sunny Island.
3. Stop the generator (see manufacturer's manual).
 - The generator is stopped. After the power-down time and the minimum stop time, you can use the generator again.

9 Disconnecting the Sunny Island from Voltage Sources

1. Stop the system (see Section 4.3, page 20).
2. Switch off the Sunny Island (see Section 4.4, page 21).
3. Disconnect the circuit breakers and the load-break switches in the sub-distributions and secure against reconnection.
4. Open the load-break switch in the DC cable and secure against reconnection.

5. **NOTICE**

Destruction of the Sunny Island inverter due to electrostatic discharge (ESD)

By touching electronic components within the Sunny Island, you can damage or destroy the Sunny Island.

- Ground yourself before touching any component.

6. Loosen all screws of the enclosure lid and remove the enclosure lid.
7. Ensure that the **DC** connection is disconnected from voltage sources.
8. Ensure that the connections **AC1 Loads/SunnyBoys**, **AC2 Gen/Grid**, and **ExtVtg** (position A) are disconnected from voltage sources.

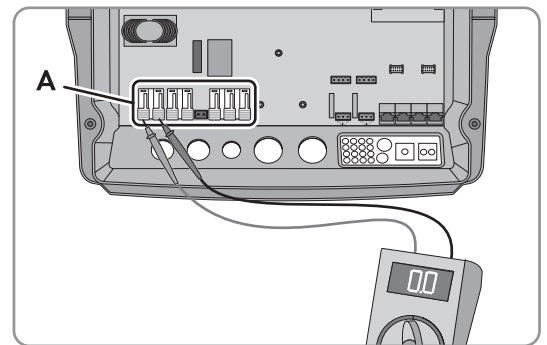

9. Ensure that the connections **Relay1** and **Relay2** (position A) are disconnected from voltage sources.

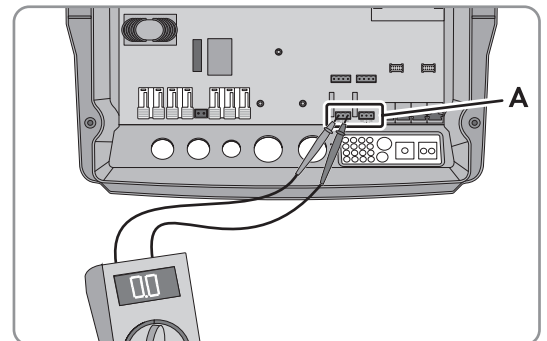

10. Ground and short-circuit the AC power cables outside the Sunny Island.
11. Cover or isolate any adjacent live components.

10 Troubleshooting

10.1 Display of Errors

10.1.1 Display of Errors on the Sunny Remote Control

Display of Errors, Warnings, and Events

Pending warnings and errors are shown automatically on the display of the Sunny Remote Control until the cause of the warning or error is no longer logged by the Sunny Island or has been acknowledged. Events are logged by the Sunny Island. The following menus log warnings, errors and events:

- **410# Error active** - display of currently pending warnings and errors
- **420# Error history** - warning and error history
- **430# Event history** - events history
- In systems for increased self-consumption and battery backup systems: **440# Error Grid** - history of the last five utility grid errors

Structure of Display Numbers

Each error and each event has a unique three-digit display number that is determined based on the parameter or measurement value assignment. Events and errors use the same number range:

- 1xx - Sunny Island
- 2xx - Battery
- 3xx - Generator or utility grid
- 4xx - Generator
- 5xx - Utility grid
- 6xx - Relay
- 7xx - System
- 8xx - External devices and components
- 9xx - General

Meaning of abbreviations

F indicates an error, **W** a warning, and **E** an event.

In the event of an error, the display shows whether the error has come or gone using **!** for "Set" and **C** for "Clear".

10.1.2 Display of Errors on the Communication Product (Example)

Most warnings, errors and events of the Sunny Island inverter can be called up and set on the communication product (e.g. Sunny Explorer or Sunny Portal). Links to additional information can be found at www.SMA-Solar.com.

Document title and content	Document type
SUNNY EXPLORER Call up and set the parameters in Sunny Portal	User Manual
SUNNY HOME MANAGER in SUNNY PORTAL Call up and set the parameters in Sunny Portal	User Manual
SUNNY ISLAND - Comparison of the same parameters for Speedwire (e.g. Sunny Explorer) and RS485 (e.g. Sunny Remote Control)	Technical Information

10.2 Sunny Island Inverter Behavior Under Fault Conditions

Error Levels

The Sunny Island distinguishes between five different levels of errors, each requiring different user interaction.

Level	Designation	Display on the Sunny Remote Control	Explanation
1	Warning	Warning	Warning; the Sunny Island continues to run. Information in standard mode indicating that a warning has been generated.
2	Malfunction 1	Malfunction	Malfunction that is detectable only during operation. The Sunny Island shuts down. Restart can be initiated immediately (e.g. via autostart).
3	Malfunction 2	Malfunction	Malfunction that is also detectable in standby mode. The Sunny Island shuts down. Restart is blocked until the malfunction is no longer detected by the Sunny Island.
4	Failure	Failure	Device failure; the Sunny Island switches off. Troubleshooting, acknowledgment of the error and manual restart necessary.
5	Device defect	Defect	The Sunny Island is defective and switches itself off. The Sunny Island must be replaced.

Handling of Pending Errors upon Activation

During the activation procedure, all pending errors are acknowledged without the error being logged in the list **420# Error history**. Errors that are still pending are entered again after activation. Errors that were detected by the Sunny Island before activation and are no longer detected after activation are shown in the list **420# Error history**.

Autostart

The autostart function allows automatic restarts in the event of malfunctions. If the autostart function fails in the event of a malfunction, the Sunny Island attempts to carry out the next autostart immediately. The number of autostarts is restricted. If the Sunny Island is in operation without malfunctions for ten minutes, it resets the autostart counter.

When the maximum number of autostarts has been reached, the Sunny Island reacts as follows:

- The Sunny Island waits ten minutes.
- The autostart counter is reset.
- The Sunny Island attempts to perform an autostart.
- When the maximum number of autostarts has been reached, the Sunny Island waits again for ten minutes.

10.3 Acknowledge Errors

If a malfunction or failure occurs, the Sunny Island switches to standby mode. Once you have eliminated the cause of the error, you can enable a restart of the Sunny Island inverter by acknowledging the error.

Procedure:

1. Eliminate the cause.
2. Press the button on the Sunny Remote Control. This acknowledges the error.
3. Start the system (see Section 4.2, page 20).

10.4 Logged Events

10.4.1 Sunny Island Category (1xx)

No.	Name	Description
E101	Standby	Waiting mode
E102	Startup	Startup process
E103	Run	Operation
E104	RunExtGn	Operation with a generator
E105	RunExtGd	Operation with the utility grid
E106	RunGdFeed	Feed-in grid operation
E108	Silent	Energy-saving mode
E110	ErrShutdown	Shutdown due to error
E115	EmgCharge	Emergency charging
E118	AutoStart	Automatic start
E119	ManStart	Manual start
E120	ManStop	Manual stop
E121	PwrSaveStart	Start of energy-saving mode
E122	PwrSaveStop	End of energy-saving mode
E129	Ext.Start	External start
E130	Ext.Stop	External stop
E133	SlfCsmptStart	Start of increased self-consumption
E134	SlfCsmptStop	Stop of increased self-consumption
E135	SlfCsmptChrgOnly	The battery is charged only when increased self-consumption is active.
E136	SlfCsmptBatMnt	Full or equalization charge with active increased self-consumption
E137	SlfCsmptNormal	Switch back to increased self-consumption after completion of full or equalization charge
E138	InvShutdown	The Sunny Island shuts down.
E140	FedInOn	Setpoint activated
E141	FedInOff	Setpoint deactivated

10.4.2 Battery Category (2xx)

No.	Name	Description
E202	BmsNewBat	(Partial) reset of battery management due to new battery
E203	BmsFloat	Battery charge algorithm switches to float charge

No.	Name	Description
E204	BmsBoost	Battery charge algorithm switches to boost charge
E205	BmsFull	Battery charge algorithm switches to full charge
E206	BmsSilent	Switches to energy-saving mode
E207	BmsEqual	Status change to equalization charge of the battery
E224	BMS20PReCal	20% recalibration being performed.

10.4.3 Generator Category (4xx)

No.	Name	Description
E401	GnAutoStart	Automatic generator start (e.g., via state-of-charge-dependent generator request)
E402	GnAutoStop	Automatic generator stop
E403	GnManStart	Manual generator start
E404	GnManStop	Manual generator stop
E405	GnManAck	Manual error acknowledgment of generator error
E406	GnDmdSrc	Generator request
E407	GnCurCtlStr	Current-controlled generator operation started
E408	GnCurCtlStp	Current-controlled generator operation stopped

10.4.4 Utility Grid Category (5xx)

No.	Name	Description
E501	GdSocOn	Grid request due to low battery state of charge
E502	GdSocOff	Grid release due to adequate battery state of charge
E503	GdPwrOn	Grid request due to power limit being exceeded
E504	GdPwrOff	Grid approval due to falling below the power limit
E505	GdManOn	Manual grid request
E506	GdManOff	Manual grid release

10.4.5 Relay Category (6xx)

No.	Name	Description
E601	Rly1Off	Multifunction relay 1 is deactivated.
E602	Rly1On	Multifunction relay 1 is activated.
E603	Rly1Slv1Off	Multifunction relay 1 of slave 1 is deactivated.
E604	Rly1Slv1On	Multifunction relay 1 of slave 1 is activated.
E605	Rly1Slv2Off	Multifunction relay 1 of slave 2 is deactivated.

No.	Name	Description
E606	Rly1Slv2On	Multifunction relay 1 of slave 2 is activated.
E609	TransferOff	Internal transfer relay is open.
E610	TransferOn	Internal transfer relay is closed.
E611	TransferSlv1Off	Internal transfer relay of slave 1 is open.
E612	TransferSlv1On	Internal transfer relay of slave 1 is closed.
E613	TransferSlv2Off	Internal transfer relay of slave 2 is open.
E614	TransferSlv2On	Internal transfer relay of slave 2 is closed.
E617	Rly2Off	Multifunction relay 2 is deactivated.
E618	Rly2On	Multifunction relay 2 is activated.
E619	Rly2Slv1Off	Multifunction relay 2 of slave 1 is deactivated.
E620	Rly2Slv1On	Multifunction relay 2 of slave 1 is activated.
E621	Rly2Slv2Off	Multifunction relay 2 of slave 2 is deactivated.
E622	Rly2Slv2On	Multifunction relay 2 of slave 2 is activated.
E625	DigInOff	No voltage at input DigIn (Low).
E626	DigInOn	Voltage at input DigIn (High).

10.4.6 System Category (7xx)

No.	Name	Description
E705	PwrOn	Device start
E706	DateSet	Date or time has been changed.
E707	NewSys	New system configured in the QCG.
E708	Fw1Update	Part 1 of the firmware updated.
E709	Fw2Update	Part 2 of the firmware updated.
E710	ClstUpdate	Cluster firmware updated.
E711	CardInsert	SD memory card is inserted.
E712	ParaUpdate	Parameter set has been loaded from SD memory card.
E715	SRCon	Sunny Remote Control is activated.
E716	PvDiscon	Disconnection of inverters whose power is not controllable depending on the frequency
E718	NoComMod1	Communication interface 1 is incorrectly plugged or missing.
E719	NoComMod2	Communication interface 2 is incorrectly plugged or missing.

10.4.7 External Device and Component Category (8xx)

No.	Name	Description
E824	UpdFileComplete	File for firmware update transferred.
E825	UpdFileCrcOK	File for firmware update is OK.
E827	UpdFileCrcNOK	File for firmware update is damaged.
E851	Sic1Detect	Sunny Island Charger 1 has been detected.
E852	Sic2Detect	Sunny Island Charger 2 has been detected.
E853	Sic3Detect	Sunny Island Charger 3 has been detected.
E854	Sic4Detect	Sunny Island Charger 4 has been detected.

10.4.8 Category External Events (9xx)

No.	Name	Description
E901	BMSStrSOCRecal	SOC recalibration started
E902	BMSStpSOCRecal	SOC recalibration stopped
E903	BMSStrPwrLim	Active power limitation started (derating)
E904	BMSStpPwrLim	Active power limitation stopped (derating)
E905	BMSPrevShutdown	Preventive battery shutdown
E906	XE06	Message of the external battery management (see battery manufacturer's documentation)
E907	XE07	Message of the external battery management (see battery manufacturer's documentation)
E908	XE08	Message of the external battery management (see battery manufacturer's documentation)

10.5 Logged Warning Messages and Error Messages

10.5.1 Sunny Island Category (1xx)

No.	Name	Level	Cause	Corrective measures
F 109	InvTmpHi	3	Overtemperature in the transformer of the device at L1: Temperature of the transformer in the master is too high due to overload or ambient temperature.	<ul style="list-style-type: none"> • Ensure that the Sunny Island is functional. For this, disconnect all AC sources and loads from the Sunny Island and restart the Sunny Island. • Reduce the total power of the loads, e.g. by staggering their use over time.
W 110	InvTmpHiSlv1	1	Overtemperature in the transformer of the device at L2: Temperature of the transformer in the slave 1 is too high due to overload or ambient temperature.	<p>⚠ QUALIFIED PERSON</p> <ul style="list-style-type: none"> • Clean the fans (see Section 11.7, page 95).
W 111	InvTmpHiSlv2	1	Overtemperature in the transformer of the device at L3: Temperature of the transformer in slave 2 is too high due to overload or ambient temperature.	
F 113	InvTmpHi	3	Overtemperature in the inverter bridge of the device at L1: Temperature of the heat sink in the master is too high due to overload or ambient temperature.	<ul style="list-style-type: none"> • Ensure that the Sunny Island is functional. For this, disconnect all AC sources and loads from the Sunny Island and restart the Sunny Island. • Reduce the total power of the loads, e.g. by staggering their use over time.
W 114	InvTmpHiSlv1	1	Overtemperature in the inverter bridge of the device at L2: Temperature of the heat sink in slave 1 is too high due to overload or ambient temperature.	
W 115	InvTmpHiSlv2	1	Overtemperature in the inverter bridge of the device at L3: Temperature of the heat sink in slave 2 is too high due to overload or ambient temperature.	

No.	Name	Level	Cause	Corrective measures
F 117	AcCurlim	2	AC current limitation Line conductor L1: The power of the loads is too high for the master.	<p>⚠ QUALIFIED PERSON</p> <ul style="list-style-type: none"> Ensure that the Sunny Island is functional. For this, clean the fans and restart the Sunny Island (see Section 11.7, page 95). Ensure that there are no short circuits in the system and that the power of the loads is not greater than the power of the Sunny Island inverter. Use a star delta electronic circuit to start three-phase loads with a high start-up electricity demand (e.g., engines). Connect the loads with very high power directly to the generator whenever possible. Ensure that the generator is not overloaded.
W 118	AcCurlimSlv1	1	AC current limitation Line conductor L2: The power of the loads is too high for slave 1.	
W 119	AcCurlimSlv2	1	AC current limitation Line conductor L3: The power of the loads is too high for slave 2.	
F 121	InvVtgHi	3	Inverter overvoltage Line conductor L1: An overvoltage has occurred at connection AC1 of the master.	<p>⚠ QUALIFIED PERSON</p> <ul style="list-style-type: none"> Ensure that the Sunny Island is functional. For this, disconnect all AC sources and loads from the Sunny Island and restart the Sunny Island. Find the cause of the overvoltage through measurement and step-by-step connection of the AC sources and loads.
W 122	InvVtgHiSlv1	1	Inverter overvoltage Line conductor L2: An overvoltage has occurred at connection AC1 of slave 1.	
W 123	InvVtgHiSlv2	1	Inverter overvoltage Line conductor L3: An overvoltage has occurred at connection AC1 of slave 2.	
F 129	InvFrqHi	3	Inverter overfrequency Line conductor L1: An overfrequency has occurred at connection AC1 of the master.	<p>⚠ QUALIFIED PERSON</p> <ul style="list-style-type: none"> Ensure that the Sunny Island is functional. For this, disconnect all AC sources and loads from the Sunny Island and restart the Sunny Island. Find the cause of the overfrequency through measurement and step-by-step connection of the AC sources and loads.
W 130	InvFrqHiSlv1	1	Inverter overfrequency Line conductor L2: An overfrequency has occurred at connection AC1 of slave 1.	
W 131	InvFrqHiSlv2	1	Inverter overfrequency Line conductor L3: An overfrequency has occurred at connection AC1 of slave 2.	

No.	Name	Level	Cause	Corrective measures
F 133	InvFrqLo	3	Inverter underfrequency Line conductor L1: An underfrequency has occurred at connection AC1 of the master.	<p>⚠ QUALIFIED PERSON</p> <ul style="list-style-type: none"> Ensure that the Sunny Island is functional. For this, disconnect all AC sources and loads from the Sunny Island and restart the Sunny Island. Find the cause of the underfrequency through measurement and step-by-step connection of the AC sources and loads.
W 134	InvFrqLoSlv1	1	Inverter underfrequency Line conductor L2: An underfrequency has occurred at connection AC1 of slave 1.	
W 135	InvFrqLoSlv2	1	Inverter underfrequency Line conductor L3: An underfrequency has occurred at connection AC1 of slave 2.	
W 137	Derate	1	Derating due to temperature L1: The master has reduced the battery charging current due to overtemperature in the Sunny Island.	<p>⚠ QUALIFIED PERSON</p> <ul style="list-style-type: none"> Reduce the total power of the loads, e.g. by staggering their use over time. Clean the fans (see Section 11.7, page 95). If the Sunny Island frequently reduces its power, increase power by replacing the Sunny Island with a higher-powered version or by installing additional Sunny Island inverters.
W 138	DerateSlv1	1	Derating due to temperature L2: slave 1 has reduced the battery charging current due to overtemperature in the Sunny Island.	
W 139	DerateSlv2	1	Derating due to temperature L3: slave 2 has reduced the battery charging current due to overtemperature in the Sunny Island.	
F 141	InvVtgLo	2	Inverter undervoltage Line conductor L1: The voltage at connection AC1 of the master is too low due to AC sources in the system.	<p>⚠ QUALIFIED PERSON</p> <ul style="list-style-type: none"> Ensure that the Sunny Island is functional. For this, disconnect all AC sources and loads from the Sunny Island and restart the Sunny Island. Find the cause of the undervoltage through measurement and step-by-step connection of the AC sources and loads.
W 142	InvVtgLoSlv1	1	Inverter undervoltage Line conductor L2: The voltage at connection AC1 of slave 1 is too low due to AC sources in the system.	
W 143	InvVtgLoSlv2	1	Inverter undervoltage Line conductor L3: The voltage at connection AC1 of slave 2 is too low due to AC sources in the system.	

No.	Name	Level	Cause	Corrective measures
F 158	VtgOnAC1Det	2	Voltage at AC connection Line conductor L1: The master has measured an undesired voltage at connection AC1 .	A bypass switch may have bridged the internal transfer relay. <ul style="list-style-type: none"> Ensure that the bypass switch is in the position for operation with the Sunny Island.
W 159	VtgOnAC1DetSlv1	1	Voltage at AC connection Line conductor L2: slave 1 has measured an undesired voltage at connection AC1 .	<p>⚠ QUALIFIED PERSON</p> <ul style="list-style-type: none"> Ensure that the bypass switch is in the position for operation with the Sunny Island. <p>An external energy source (e.g., generator) may have been connected to the connection AC1.</p>
W 160	VtgOnAC1DetSlv2	1	Voltage at AC connection Line conductor L3: slave 2 has measured an undesired voltage at connection AC1 .	<p>⚠ QUALIFIED PERSON</p> <ul style="list-style-type: none"> Disconnect external energy source from connection AC1 and connect to connection AC2 (see the Sunny Island inverter installation manual).
F 162	OvrCurDet	2	Too much current is flowing through the DC connection of the master.	<ul style="list-style-type: none"> Reduce the power of the loads.
W 163	OvrCurDetSlv1	1	Too much current is flowing through the DC connection of slave 1.	
W 164	OvrCurDetSlv2	1	Too much current is flowing through the DC connection of slave 2.	
F 166	Overload5min	3	The device at L1 (Master) has been loaded over its five-minute rated capacity.	<ul style="list-style-type: none"> Reduce the power of the loads.
W 167	Overload5minSlv1	1	The device at L2 (slave 1) has been loaded over its five-minute rated capacity.	
W 168	Overload5minSlv2	1	The device at L3 (slave 2) has been loaded over its five-minute rated capacity.	

No.	Name	Level	Cause	Corrective measures
F 169	Overload30min	3	The device at L1 (Master) has been loaded over its 30-minute rated capacity.	<ul style="list-style-type: none"> Reduce the power of the loads.
W 170	Overload30minSlv1	1	The device at L2 (slave 1) has been loaded over its 30-minute rated capacity.	
W 171	Overload30minSlv2	1	The device at L3 (slave 2) has been loaded over its 30-minute rated capacity.	
F 172	Overload	3	The device at L1 (Master) has been loaded over its rated short-term capacity.	<ul style="list-style-type: none"> Reduce the power of the loads.
W 173	OverloadSlv1	1	The device at L2 (slave 1) has been loaded over its rated short-term capacity.	
W 174	OverloadSlv2	1	The device at L3 (slave 2) has been loaded over its rated short-term capacity.	
F 175	StopSlvError	1	slave is in Fault mode. The cluster is stopped.	<ul style="list-style-type: none"> Contact the Service (see Section 16 "Contact", page 161).
F 176	CurTrfSns	4	The current sensor is not connected, not available or defective.	
W 177	SlfCsmBatRes	1	The deep discharge protection area BatResSoc has been reached.	<p>⚠ QUALIFIED PERSON</p> <p>A fuse may have tripped at the grid-connection point.</p> <ul style="list-style-type: none"> Activate the fuse. Replace the fuse if necessary. <p>The utility grid may not work within the set system limits.</p> <ul style="list-style-type: none"> Check whether the grid parameters is still within the set system limits. Contact the grid operator if necessary.
W 178	SlfCsmProRes	1	The deep discharge protection area prior to disconnection ProResSOC has been reached.	

No.	Name	Level	Cause	Corrective measures
F 179	RetryConFail	4	The pre-fuse F104.1 in the Multicluster-Box is open. The master in the main cluster detects a supply voltage at ExtVtg and tries to switch to line conductor L1 in the multicluster system. At line conductor L1 an anti-islanding error occurs due to the open pre-fuse.	<p>⚠ QUALIFIED PERSON</p> <ul style="list-style-type: none"> Reactivate the pre-fuse. Check the voltage supply at terminal AC2 of the master in the main cluster.
W 180	RetryConFailS1	4	The pre-fuse F104.2 in the Multicluster-Box is open. The master in the main cluster detects a supply voltage at ExtVtg and tries to switch to Phase L2 in the multicluster system. At line conductor L2 an anti-islanding error occurs due to the open pre-fuse.	
W 181	RetryConFailS2	4	The pre-fuse F104.3 in the Multicluster-Box is open. The master in the main cluster detects a supply voltage at ExtVtg and tries to switch to line conductor L3 in the multicluster system. At line conductor L3 an anti-islanding error occurs due to the open pre-fuse.	

10.5.2 Battery Category (2xx)

No.	Name	Level	Cause	Corrective measures
F 201	VBATMAX	2	Measuring range of battery voltage exceeded in device at L1: Battery voltage at the master is above the permissible measurement range.	<ul style="list-style-type: none"> Check whether the value of the parameter 120.02 BatVtg is above 65.0 V. If the value is above 65.0 V, check the settings of the DC sources and ensure that the battery capacity is sufficient. When doing so, bear in mind the technical data for the battery at the DC connection (see the Sunny Island inverter installation manual).
W 202	VBATMAXSL1	1	Measuring range of battery voltage exceeded in device at L2: Battery voltage at slave 1 is above the permissible measurement range.	<p>⚠ QUALIFIED PERSON</p> <ul style="list-style-type: none"> Ensure that the DC sources are correctly connected and configured.
W 203	VBATMAXSL2	1	Measuring range of battery voltage exceeded in device at L3: Battery voltage at slave 2 is above the permissible measurement range.	

No.	Name	Level	Cause	Corrective measures
F 206	BatTmpHi	3	Overtemperature fault in battery: The battery temperature is too high.	<ul style="list-style-type: none"> Wait for the battery to cool down. Useful hint: Protect the battery against temperatures above 25°C. This helps prevent premature aging of the battery. <p>⚠ QUALIFIED PERSON</p> <ul style="list-style-type: none"> Check whether the electrical resistance of the battery temperature sensor is approx. 2000 Ω at 20°C to 25°C. If the resistance deviates strongly from this value, replace the sensor.
F 208	BatVtgHi	3	Measuring range of battery voltage exceeded in device at L2: Battery voltage is higher than the target charge voltage.	<p>⚠ QUALIFIED PERSON</p> <ul style="list-style-type: none"> Ensure that all DC sources are correctly configured. Ensure that all SMA inverters are configured to the country data set for stand-alone grid operation.
W 209	BatVtgWrnHi	1	The battery voltage is too high and has not been generated by the device.	
W 210	BatVtgHiWarn	1	Battery overvoltage: Battery voltage is temporarily too high.	
W 211	BatTmpLoWarn	1	Undertemperature fault in battery: The battery temperature is too low.	<ul style="list-style-type: none"> Ensure that the battery room is sufficiently warm.
W 212	BatTmpHiWarn	1	Overtemperature fault in battery: The battery temperature is too high.	<ul style="list-style-type: none"> Wait for the battery to cool down. Useful hint: Protect the battery against temperatures above 25°C. This helps prevent premature aging of the battery.
F 213	BatVtgLow	3	Battery undervoltage: Battery voltage is too low.	<p>⚠ QUALIFIED PERSON</p> <ul style="list-style-type: none"> Charge the battery in emergency charge operation or using an external battery charger (see Section 10.7 "Charging the Battery After Automatic Shutdown in Off-Grid Systems (Emergency Charge Mode)", page 89). Ensure that DC loads are shed via a load-shedding contactor when the battery state of charge is low.
W 220	BatSOH70Warn	1	Current battery capacity (SOH) is below 70%.	<p>⚠ QUALIFIED PERSON</p> <ul style="list-style-type: none"> Verify the plausibility of the error message and replace the battery if necessary.

No.	Name	Level	Cause	Corrective measures
F 221	InvalidBatType	4	External battery management detected but not configured.	<p>⚠ QUALIFIED PERSON</p> <ul style="list-style-type: none"> Start QCG and configure a new system with external energy management (e.g., system with lithium-ion battery).
W 222	CheckBat	1	A 20% recalibration of the battery state of charge has been performed with a jump of more than 10%.	<ul style="list-style-type: none"> Check the battery.

10.5.3 Generator or Utility Grid Category (3xx)

No.	Name	Level	Cause	Corrective measures
W 309	RlyProtect	1	Excessive current has been applied to the transfer relay of the device at L1: Excessive current has been applied to the internal transfer relay of the master.	<ul style="list-style-type: none"> Reduce the total power of the loads, e.g. by staggering their use over time. <p>⚠ QUALIFIED PERSON</p> <ul style="list-style-type: none"> Connect the loads with very high power directly to the generator whenever possible or connect the utility grid. Ensure that the generator is not overloaded. In off-grid systems, ensure that the country data sets of the SMA inverters are set to stand-alone grid operation (see the installation manuals of the SMA inverters).
W 310	RlyProtectSlv1	1	Excessive current has been applied to the transfer relay of the device at L2: Excessive current has been applied to the internal transfer relay of slave 1.	<ul style="list-style-type: none"> In off-grid systems, ensure that the country data sets of the SMA inverters are set to stand-alone grid operation (see the installation manuals of the SMA inverters).
W 311	RlyProtectSlv2	1	Excessive current has been applied to the transfer relay of the device at L3: Excessive current has been applied to the internal transfer relay of slave 2.	<ul style="list-style-type: none"> In off-grid systems, ensure that the country data sets of the SMA inverters are set to stand-alone grid operation (see the installation manuals of the SMA inverters).
F 314	ExtVtgLoss	2	External voltage failure: The voltage and/or frequency of the generator or the utility grid are outside of the configured range.	<p>Corrective measures for a generator:</p> <p>⚠ QUALIFIED PERSON</p> <ul style="list-style-type: none"> Adjust the thresholds for generator frequency and/or voltage on the Sunny Island (see the Sunny Island inverter installation manual). Observe and analyze the measured values 134.02 ExtVtg and 134.04 ExtFrq during operation. Adjust the generator voltage and/or generator frequency. <p>Corrective measures in battery backup systems:</p> <ul style="list-style-type: none"> Contact the Service, if required (see Section 16 "Contact", page 161).

No.	Name	Level	Cause	Corrective measures
W 315	ExtVtgLo	1	Disconnection from the external grid due to undervoltage at line conductor L1: The voltage of the generator or the utility grid at the master is too low.	<p>Corrective measures for a generator:</p> <p>⚠ QUALIFIED PERSON</p> <ul style="list-style-type: none"> Adjust the thresholds for generator voltage on the Sunny Island (see the Sunny Island inverter installation manual). Observe and analyze the measured values 134.02 ExtVtg during operation. Adjust the generator voltage and/or generator frequency.
W 316	ExtVtgLoSlv1	1	Disconnection from the external grid due to undervoltage at line conductor L2: The voltage of the generator or the utility grid at slave 1 is too low.	
W 317	ExtVtgLoSlv2	1	Disconnection from the external grid due to undervoltage at line conductor L3: The voltage of the generator or the utility grid at slave 2 is too low.	<p>Corrective measures in battery backup systems:</p> <ul style="list-style-type: none"> Contact the Service, if required (see Section 16 "Contact", page 161).
W 319	ExtVtgHi	1	Disconnection from the external grid due to overvoltage at line conductor L1: The voltage of the generator or the utility grid at the master is too high.	<p>Corrective measures for a generator:</p> <p>⚠ QUALIFIED PERSON</p> <ul style="list-style-type: none"> Adjust the thresholds for generator voltage on the Sunny Island (see the Sunny Island inverter installation manual). Observe and analyze the measured values 134.02 ExtVtg during operation. Adjust the generator voltage and/or generator frequency.
W 320	ExtVtgHiSlv1	1	Disconnection from the external grid due to overvoltage at line conductor L2: The voltage of the generator or the utility grid at slave 1 is too high.	
W 321	ExtVtgHiSlv2	1	Disconnection from the external grid due to overvoltage at line conductor L3: The voltage of the generator or the utility grid at slave 2 is too high.	<p>Corrective measures in battery backup systems:</p> <ul style="list-style-type: none"> Contact the Service, if required (see Section 16 "Contact", page 161).

No.	Name	Level	Cause	Corrective measures
W 323	ExtFrqLo	1	Disconnection from the external grid due to too low frequency at line conductor L1: The frequency of the generator or the utility grid at the master is too low.	<p>Corrective measures for a generator:</p> <ul style="list-style-type: none"> The generator may be overloaded. Reduce the total power of the loads by staggering their use over time.
W 324	ExtFrqLoSlv1	1	Disconnection from the external grid due to too low frequency at line conductor L2: The frequency of the generator or the utility grid at slave 1 is too low.	<p>⚠ QUALIFIED PERSON</p> <ul style="list-style-type: none"> Adjust the thresholds for generator frequency on the Sunny Island (see the Sunny Island inverter installation manual). Observe and analyze the measured values 134.04 ExtFrq during operation. Adjust the frequency of the external energy source.
W 325	ExtFrqLoSlv2	1	Disconnection from the external grid due to too low frequency at line conductor L3: The frequency of the generator or the utility grid at slave 2 is too low.	<p>Corrective measures for a utility grid:</p> <ul style="list-style-type: none"> Contact the Service, if required (see Section 16 "Contact", page 161).
W 327	ExtFrqHi	1	Disconnection from the external grid due to too high frequency at line conductor L1: The frequency of the generator or the utility grid at the master is too high.	<p>Corrective measures for a generator:</p> <ul style="list-style-type: none"> The generator may be overloaded. Reduce the total power of the loads by staggering their use over time.
W 328	ExtFrqHiSlv1	1	Disconnection from the external grid due to too high frequency at line conductor L2: The frequency of the generator or the utility grid at slave 1 is too high.	<p>⚠ QUALIFIED PERSON</p> <ul style="list-style-type: none"> Adjust the thresholds for generator frequency on the Sunny Island (see the Sunny Island inverter installation manual). Observe and analyze the measured values 134.04 ExtFrq during operation. Adjust the frequency of the external energy source.
W 329	ExtFrqHiSlv2	1	Disconnection from the external grid due to too high frequency at line conductor L3: The frequency of the generator or the utility grid at slave 2 is too high.	<p>Corrective measures for a utility grid:</p> <ul style="list-style-type: none"> Contact the Service, if required (see Section 16 "Contact", page 161).

No.	Name	Level	Cause	Corrective measures
W 331	Antilsl	1	Disconnection from the external grid due to undesired stand-alone grid at line conductor L1: Undesired stand-alone grid is present at connection AC2 of the master.	<p>⚠ QUALIFIED PERSON</p> <ul style="list-style-type: none"> Ensure that the insulated wires at connection AC2 are securely connected and that the conductors in the terminals are free of insulation.
W 332	AntilslSlv1	1	Disconnection from the external grid due to undesired stand-alone grid at line conductor L2: Undesired stand-alone grid is present at connection AC2 of slave 1.	<p>Corrective measures for a generator:</p> <p>This may be caused by a contactor between the generator and the Sunny Island.</p> <ul style="list-style-type: none"> Control of the contactor via a Sunny Island inverter multifunction relay. Set the parameter of the multifunction relay, e.g., 241.01 Rly1Op, to AutoGn. Set the parameter 234.20 GdAiSns to a lower sensitivity. <p>Corrective measures for a utility grid:</p> <ul style="list-style-type: none"> Contact the Service, if required (see Section 16 "Contact", page 161).
W 333	AntilslSlv2	1	Disconnection from the external grid due to undesired stand-alone grid at line conductor L3: Undesired stand-alone grid is present at connection AC2 of slave 2.	<p>Corrective measures for a utility grid:</p> <ul style="list-style-type: none"> Contact the Service, if required (see Section 16 "Contact", page 161).
W 335	ExtVtgRdtErr	1	Disconnection from external source due to exceeding the configured thresholds in the device at L1: The voltage of the generator or the utility grid at the master is outside the configured thresholds (redundant measurement).	<p>Corrective measures for a generator:</p> <p>⚠ QUALIFIED PERSON</p> <ul style="list-style-type: none"> Adjust the thresholds for generator voltage on the Sunny Island (see the Sunny Island inverter installation manual). Observe and analyze the measured values 134.02 ExtVtg during operation. If possible, adjust the generator voltage. <p>Corrective measures for a utility grid:</p> <ul style="list-style-type: none"> Contact the Service, if required (see Section 16 "Contact", page 161).
W 336	ExtVtgRdtErrSlv1	1	Disconnection from external source due to exceeding the configured thresholds in the device at L2: The voltage of the generator or the utility grid at slave 1 is outside the configured thresholds (redundant measurement).	<p>Corrective measures for a utility grid:</p> <ul style="list-style-type: none"> Contact the Service, if required (see Section 16 "Contact", page 161).
W 337	ExtVtgRdtErrSlv2	1	Disconnection from external source due to exceeding the configured thresholds in the device at L3: The voltage of the generator or the utility grid at slave 2 is outside the configured thresholds (redundant measurement).	<p>Corrective measures for a utility grid:</p> <ul style="list-style-type: none"> Contact the Service, if required (see Section 16 "Contact", page 161).

No.	Name	Level	Cause	Corrective measures
W 339	ExtVtgIncPro	1	Voltage increase protection Line conductor L1	<p>⚠ QUALIFIED PERSON</p> <ul style="list-style-type: none"> Ensure that the conductor cross-section of the AC cables is correctly sized.
W 340	ExtVtgIncProSlv1	1	Voltage increase protection of line conductor L2	
W 341	ExtVtgIncProSlv2	1	Voltage increase protection Line conductor L3	
W 343	AcVtglim	1	Disconnection from the external grid due to insufficient battery voltage or overvoltage at line conductor L1: The master disconnects from the external energy source because the voltage at connection AC2 is too high or the battery voltage too low.	<ul style="list-style-type: none"> Contact the Service, if required (see Section 16 "Contact", page 161).
W 344	AcVtglimSlv1	1	Disconnection from the external grid due to insufficient battery voltage or overvoltage at line conductor L2: Slave 1 disconnects from the external energy source because the voltage at connection AC2 is too high or the battery voltage too low.	
W 345	AcVtglimSlv2	1	Disconnection from the external grid due to insufficient battery voltage or overvoltage at line conductor L3: Slave 2 disconnects from the external energy source because the voltage at connection AC2 is too high or the battery voltage too low.	

No.	Name	Level	Cause	Corrective measures
W 347	ExtOverload	1	Disconnection from the external grid due to line conductor failure or overload at line conductor 1: The master disconnects from the utility grid due to line conductor failure/overload at connection AC2 .	<ul style="list-style-type: none"> Reduce the total power of the loads, e.g. by staggering their use over time. <p>⚠ QUALIFIED PERSON</p> <ul style="list-style-type: none"> Ensure that there is not a short circuit present at connection AC2.
W 348	ExtOverloadSlv1	1	Disconnection from the external grid due to line conductor failure or overload at line conductor 2: Slave 1 disconnects from the utility grid due to line conductor failure/overload at connection AC2 .	
W 349	ExtOverloadSlv2	1	Disconnection from the external grid due to line conductor failure or overload at line conductor 3: Slave 2 disconnects from the utility grid due to line conductor failure/overload at connection AC2 .	
W 351	ExtScirDet	1	Disconnection from the external grid due to external short circuit at line conductor L1: Short circuit is present at connection AC2 of the master.	<p>⚠ QUALIFIED PERSON</p> <ul style="list-style-type: none"> Eliminate the short circuit.
W 352	ExtScirDetSlv1	1	Disconnection from the external grid due to external short circuit at line conductor L2: Short circuit is present at connection AC2 of slave 1.	
W 353	ExtScirDetSlv2	1	Disconnection from the external grid due to external short circuit at line conductor L3: Short circuit is present at connection AC2 of slave 2.	
W 355	PhsAngErr	1	External grid does not have a correct rotating magnetic field: Assignment of the line conductors of the external energy source to the AC2 connections of the Sunny Island does not result in a right-rotating magnetic field.	<p>⚠ QUALIFIED PERSON</p> <ul style="list-style-type: none"> Ensure that the master is connected to L1, slave 1 to L2, and slave 2 to L3.

No.	Name	Level	Cause	Corrective measures
F 364	PhsPwrFail	2	The Sunny Island system disconnects from the generator or utility grid due to a voltage imbalance between the line conductors.	<p>⚠ QUALIFIED PERSON</p> <ul style="list-style-type: none"> Eliminate any faults in the installation.
F 365	VAcExtPhsFail	3	Phase position of the measured AC voltage at VExt and AC2 does not match at line conductor L1 (Master).	<p>⚠ QUALIFIED PERSON</p> <ul style="list-style-type: none"> Ensure that the neutral conductor and line conductor are correctly connected to connection ExtVtg. Ensure that the neutral conductor and line conductor are correctly connected to connection AC2. Ensure that connections ExtVtg and AC2 are connected to the same line conductor.
F 366	HotAcBus	3	When the tie switch is open, AC voltage is present at line conductor L1 (Master).	<p>⚠ QUALIFIED PERSON</p> <ul style="list-style-type: none"> Ensure that the triggering of the tie switch is correct. Ensure that the tie switch is correctly wired.
F 367	ExtCtcNotOpen	3	Tie switch does not open.	<p>⚠ QUALIFIED PERSON</p> <ul style="list-style-type: none"> Ensure that the triggering of the tie switch is correct. Ensure that the tie switch is correctly wired. Ensure that the feedback contact is correctly connected.
F 368	NRelNotOpen	3	Neutral conductor relay does not open at L1 (Master).	<ul style="list-style-type: none"> Contact the Service (see Section 16 "Contact", page 161).
W 369	NRelNotOpenSlv1	1	Neutral conductor relay does not open at L2 (slave 1).	
W 370	NRelNotOpenSlv2	1	Neutral conductor relay does not open at L3 (slave 2).	

No.	Name	Level	Cause	Corrective measures
W 372	VtgFrqRatio	1	Disconnection from the external grid or generator due to non-compliance with the voltage-frequency ratio at line conductor L1 (Master)	<ul style="list-style-type: none"> Contact the Service, if required (see Section 16 "Contact", page 161).
W 373	VtgFrqRatioSlv1	1	Disconnection from the external grid due to non-compliance with the voltage-frequency ratio at line conductor L2 (slave 1)	
W 374	VtgFrqRatioSlv2	1	Disconnection from the utility grid due to non-compliance with the voltage-frequency ratio at line conductor L3 (slave 2)	
F 376	ExtCtcNotClose	3	Tie switch does not close.	<p>⚠ QUALIFIED PERSON</p> <ul style="list-style-type: none"> Ensure that the triggering of the tie switch is correct. Ensure that the tie switch is correctly wired. Ensure that the feedback contact is correctly connected.
W 377	ExtCurExCeed	1	The external current measured on L1 exceeds the set parameter value 232.04 GdCurNom or 234.03 GnCurNom by 2%.	<p>⚠ QUALIFIED PERSON</p> <ul style="list-style-type: none"> Reduce power consumption of all loads. Reduce power output of the AC sources (e.g. PV inverter).
W 378	ExCurExcSlv1	1	The external current measured on L2 exceeds the set parameter value 232.04 GdCurNom or 234.03 GnCurNom by 2%.	
W 379	ExCurExcSlv2	1	The external current measured on L3 exceeds the set parameter value 232.04 GdCurNom or 234.03 GnCurNom by 2%.	
W 380	VAcExtPhsFailS1	1	Phase position of the measured AC voltage at VExt and AC2 does not match at line conductor L2 (slave 1).	<p>⚠ QUALIFIED PERSON</p> <ul style="list-style-type: none"> Ensure that the neutral conductor and line conductor are correctly connected to connection ExtVtg. Ensure that the neutral conductor and line conductor are correctly connected to connection AC2. Ensure that connections ExtVtg and AC2 are connected to the same line conductor.
W 381	VAcExtPhsFailS2	1	Phase position of the measured AC voltage at VExt and AC2 does not match at line conductor L3 (slave 2).	

No.	Name	Level	Cause	Corrective measures
W 383	HotAcBusSlv1	1	When the tie switch is open, AC voltage is present at line conductor L2 (slave 1).	<p>⚠ QUALIFIED PERSON</p> <ul style="list-style-type: none"> Ensure that the triggering of the tie switch is correct.
W 384	HotAcBusSlv2	1	When the tie switch is open, AC voltage is present at line conductor L3 (slave 2).	<ul style="list-style-type: none"> Ensure that the tie switch is correctly wired.

10.5.4 Generator Category (4xx)

No.	Name	Level	Cause	Corrective measures
W 401	GnRevPwrProt	1	Reverse power protection (Generator): AC sources in the system are driving the generator. The reverse power in the generator has been exceeded for too long.	<ul style="list-style-type: none"> Adjust the generator request to the properties of the AC sources in the system and the loads, e.g., for PV inverters, preferably request the generator at night. <p>⚠ QUALIFIED PERSON</p> <ul style="list-style-type: none"> If the generator can absorb reverse power, adjust the settings for reverse power (see the Sunny Island inverter installation manual).
W 402	GnFailLock	1	Blocking of generator due to too many interrupted start-ups	<p>⚠ QUALIFIED PERSON</p> <ul style="list-style-type: none"> Ensure that the generator triggering is functioning, the generator starts, and there is constant and stable generator voltage present at connection AC2. To re-enable connection of the generator, acknowledge the generator error (see Section 10.3 "Acknowledge Errors", page 47). <p>⚠ QUALIFIED PERSON</p> <p>A warm-up time 234.12 GnWarmTm that is too short may have been configured and hence the generator is unable to supply valid voltage.</p> <ul style="list-style-type: none"> Ensure that the generator warm-up time is configured appropriately (see the Sunny Island inverter installation manual).

10.5.5 Utility Grid Category (5xx)

No.	Name	Level	Cause	Corrective measures
W 501	GdRevPwrProt	1	Non-permitted reverse feeding into the utility grid at line conductor L1 (Master)	Contact the Service, if required (see Section 16 "Contact", page 161).
W 502	GdRevPwrProtSL1	1	Non-permitted reverse feeding into the utility grid at line conductor L2 (slave 1)	
W 503	GdRevPwrProtSL2	1	Non-permitted reverse feeding into the utility grid at line conductor L3 (slave 2)	
W 505	GdCurNomExceed	1	At line conductor L1 (Master), the feed-in current is greater than the set maximum value 232.04 GdCurNom.	Contact the Service, if required (see Section 16 "Contact", page 161).
W 506	GdCurNomExcSlv1	1	At line conductor L2 (slave 1), the feed-in current is greater than the set maximum value 232.04 GdCurNom.	
W 507	GdCurNomExcSlv2	1	At line conductor L3 (slave 2), the feed-in current is greater than the set maximum value 232.04 GdCurNom.	

10.5.6 Relay Category (6xx)

No.	Name	Level	Cause	Corrective measures
F 605	TransfNotOpn	4	Transfer relay does not open at line conductor L1 (Master).	A bypass switch may have bridged the internal transfer relay.
W 606	TransfNotOpnSL1	1	Transfer relay does not open at line conductor L2 (slave 1).	<ul style="list-style-type: none"> Ensure that the bypass switch is in the position for operation with the Sunny Island.
W 607	TransfNotOpnSL2	1	Transfer relay does not open at line conductor L3 (slave 2).	<p>⚠ QUALIFIED PERSON</p> <ul style="list-style-type: none"> Ensure that the connections AC1 and AC2 are not bridged.

10.5.7 System Category (7xx)

No.	Name	Level	Cause	Corrective measures
F 702	RsDsp	5	Reset of the signal processor in the device at L1 has been identified.	<ul style="list-style-type: none"> Contact the Service (see Section 16 "Contact", page 161).
F 703	TimeOut	2	Internal timing fault: Time for performing a particular task has been exceeded.	<ul style="list-style-type: none"> Contact the Service (see Section 16 "Contact", page 161).

No.	Name	Level	Cause	Corrective measures
F 704	Calib	4	Invalid Calibration in DSP: The system has not calibrated.	<ul style="list-style-type: none"> Contact the Service (see Section 16 "Contact", page 161).
W 705	TimeOut	1	Watchdog DSP: The watchdog of the signal processor of the master has tripped.	<ul style="list-style-type: none"> Contact the Service, if required (see Section 16 "Contact", page 161).
F 706	TimeOut	4	Frequent watchdog fault: The watchdog of the signal processor of the master has tripped several times.	<ul style="list-style-type: none"> Contact the Service (see Section 16 "Contact", page 161).
W 707	TimeOutSlv1	1	Watchdog meter on slave 1 elapsed (watchdog tripped several times in succession)	
W 708	TimeOutSlv2	1	Watchdog meter on slave 2 elapsed (watchdog tripped several times in succession).	
F 710	AutoStrCnt	4	Autostart meter elapsed in the device at L1 (several autostarts in succession).	<ul style="list-style-type: none"> Ensure that the parameter 250.01 AutoStr is set to 3. <p>⚠ QUALIFIED PERSON</p> <ul style="list-style-type: none"> Read off the pending and logged warnings and errors and eliminate the causes.
W 713	TimeOut	1	Watchdog OCU: The watchdog of the operation control unit has tripped.	<ul style="list-style-type: none"> Contact the Service, if required (see Section 16 "Contact", page 161).
W 715	MMCUpdFail	1	The update cannot be carried out. The type or format of the SD memory card is not supported.	Copy the update file to an SD memory card with maximum 2 GB and with FAT-16 format.
F 716	VBATMIN	2	Measuring range of battery voltage exceeded in device at L1: Battery voltage at the master is below the permissible measurement range.	<ul style="list-style-type: none"> Disconnect the DC loads and charge the battery. <p>The usable battery capacity may be too small, e.g., due to aging. If a load with high power connects, the battery voltage collapses.</p>
W 717	VBATMINSL1	1	Measuring range of battery voltage exceeded in device at L2: Battery voltage at slave 1 is below the permissible measurement range.	<p>⚠ QUALIFIED PERSON</p> <ul style="list-style-type: none"> If DC loads are installed in the system, install load shedding for DC loads.
W 718	VBATMINSL2	1	Measuring range of battery voltage exceeded in device at L3: Battery voltage at slave 2 is below the permissible measurement range.	<ul style="list-style-type: none"> Ensure that all battery cells are functional.

No.	Name	Level	Cause	Corrective measures
F 720	InvTmpSns	4	Short circuit or cable break on the temperature sensor of the transformer L1 (Master).	<ul style="list-style-type: none"> Contact the Service (see Section 16 "Contact", page 161).
F 721	InvTmpSns	4	Short circuit or cable break on the temperature sensor of the inverter bridge L1 (Master).	<ul style="list-style-type: none"> Contact the Service (see Section 16 "Contact", page 161).
W 722	BatTmpSnsShort	1	Short circuit on battery temperature sensor	<p>⚠ QUALIFIED PERSON</p> <ul style="list-style-type: none"> Ensure that the battery temperature sensor is correctly connected (see the Sunny Island inverter installation manual). Contact the Service (see Section 16 "Contact", page 161).
W 723	BatTmpSnsOpn	1	Cable break on battery temperature sensor	
W 724	AutoStrCntSlv1	1	Autostart meter elapsed in the device at L2: Maximum number of autostarts for slave 1 has been reached.	<p>⚠ QUALIFIED PERSON</p> <ul style="list-style-type: none"> Read off the pending and logged warnings and errors and eliminate the causes. Ensure that the parameter 250.01 AutoStr is set to 3.
W 725	AutoStrCntSlv2	1	Autostart meter elapsed in the device at L3: Maximum number of autostarts for slave 2 has been reached.	
F 731	ClstConfig	4	Error in the cluster configuration	<p>⚠ QUALIFIED PERSON</p> <ul style="list-style-type: none"> Change the addresses of the slaves in the cluster (see Section 10.8, page 91)
F 733	MstrLoss	4	No message from Master (only slave): Communication with the Master is interrupted.	<p>⚠ QUALIFIED PERSON</p> <ul style="list-style-type: none"> Ensure that undamaged CAT5e cables are used for communication and that the cables are plugged in correctly. Ensure that the communication bus is equipped with a terminator at both ends.
W 734	Slv1Loss	1	No message from device to L2: Communication from the Master to slave 1 is interrupted.	
W 735	Slv2Loss	1	No message from device to L3: Communication from the Master to slave 2 is interrupted.	
F 737	BootUpdateFail	4	Updating of the boot loader failed.	<ul style="list-style-type: none"> Contact the Service (see Section 16 "Contact", page 161).

No.	Name	Level	Cause	Corrective measures
W 738	GnSynLoss	1	Synchronization with the generator not successful.	<ul style="list-style-type: none"> Ensure that the generator can be started. The fuel level may be too low. <p>⚠ QUALIFIED PERSON</p> <ul style="list-style-type: none"> Ensure that a constant and stable voltage is present at connection AC2. Ensure that the thresholds for the generator voltage are correctly configured.
F 739	SPICom	3	No message from the device at L1: Internal device communication of the master is disturbed.	<ul style="list-style-type: none"> Contact the Service (see Section 16 "Contact", page 161).
W 740	SPIComSlv1	1	No message from the device at L2: Internal device communication of slave 1 is disturbed.	
W 741	SPIComSlv2	1	No message from the device at L3: Internal device communication of slave 2 is disturbed.	
F 743	CANCom	3	Internal CAN communication is missing in the device at L1 (Master).	<ul style="list-style-type: none"> Contact the Service (see Section 16 "Contact", page 161). <p>⚠ QUALIFIED PERSON</p>
W 744	CANComSlv1	1	Internal CAN communication is missing in the device at L2 (slave 1).	<ul style="list-style-type: none"> Ensure that the terminators in the communication bus are attached.
W 745	CANComSlv2	1	Internal CAN communication is missing in the device at L3 (slave 2).	<ul style="list-style-type: none"> Ensure that undamaged CAT5e cables are used for communication and that the cables are plugged in correctly.
W 747	InvTmpSnsSlv1	1	Short circuit or cable break on the temperature sensor of the transformer L2 (slave 1).	<ul style="list-style-type: none"> Contact the Service (see Section 16 "Contact", page 161).
W 748	InvTmpSnsSlv2	1	Short circuit or cable break on the temperature sensor of the transformer L3 (slave 2).	
W 750	InvTmpSnsSlv1	1	Short circuit or cable break on the temperature sensor of the inverter bridge L2 (slave 1).	<ul style="list-style-type: none"> Contact the Service (see Section 16 "Contact", page 161).
W 751	InvTmpSnsSlv2	1	Short circuit or cable break on the temperature sensor of the inverter bridge L3 (slave 2).	

No.	Name	Level	Cause	Corrective measures
W 753	DateInvalid	1	Invalid date: System time is invalid.	<ul style="list-style-type: none"> Select the parameter 250.02 Dt and set the date. Select the parameter 250.03 Tm and set the time.
F 754	BoxCom	2	Communication with MC BOX is interrupted: Communication with Multicluster-Box is interrupted.	<p>⚠ QUALIFIED PERSON</p> <ul style="list-style-type: none"> Ensure that undamaged CAT5e cables are used for communication and that the cables are plugged in correctly. Ensure that the communication bus is equipped with a terminator at both ends.
W 755	LoBatMod1	1	Battery protection mode 1 is activated.	<ul style="list-style-type: none"> Disconnect the loads, start the generator, start the Sunny Island and charge the battery.
W 756	LoBatMod2	1	Battery protection mode 2 is activated.	
W 757	LoBatMod3	1	Battery protection mode 3 is activated.	
F 758	McNoVtg	2	Voltage of the main cluster cannot be measured at L1 (Master).	<ul style="list-style-type: none"> Ensure that all circuit breakers of the Sunny Island inverters in the Multicluster-Box are closed. <p>⚠ QUALIFIED PERSON</p> <ul style="list-style-type: none"> Ensure that the cabling at connection ACT1 is correctly installed.
W 759	McNoVtgSv1	1	Voltage of the main cluster cannot be measured at L2 (slave 1).	
W 760	McNoVtgSlv2	1	Voltage of the main cluster cannot be measured at L3 (slave 2).	
W 778	DSPNoSlv1	1	CAN communication with slave 1 is faulty.	<p>⚠ QUALIFIED PERSON</p> <ul style="list-style-type: none"> Ensure that undamaged CAT5e cables are used for communication and that the cables are plugged in correctly. Ensure that the communication bus is equipped with a terminator at both ends.
W 779	DSPNoSlv2	1	CAN communication with slave 2 is faulty.	
F 781	SlvError	4	Error at a slave in the main cluster causing system shutdown.	<p>⚠ QUALIFIED PERSON</p> <p>Read off the pending and logged warnings and errors and eliminate the causes.</p>
F 782	AlVtgMonFail	4	Non-compliance of monitoring times (islanding detection) and external grid voltage in the device at L1 (Master)	<ul style="list-style-type: none"> Contact the Service (see Section 16 "Contact", page 161).

No.	Name	Level	Cause	Corrective measures
F 783	CANCom	2	Device-internal sync pulse in the device at L1 (Master) is missing.	⚠ QUALIFIED PERSON <ul style="list-style-type: none"> Ensure that undamaged CAT5e cables are used for communication and that the cables are plugged in correctly. Ensure that the communication bus is equipped with a terminator at both ends.
W 784	CANComSlv1	1	Device-internal sync pulse in the device at L2 (slave 1) is missing.	
W 785	CANComSlv2	1	Device-internal sync pulse in the device at L3 (slave 2) is missing.	<ul style="list-style-type: none"> Contact the Service (see Section 16 "Contact", page 161).
F 787	VcoreFail	3	Processor voltage in the device at L1 (Master) is incorrect.	
F 788	VcoreFailSlv1	3	Processor voltage in the device at L2 (slave 1) is incorrect.	<ul style="list-style-type: none"> Contact the Service (see Section 16 "Contact", page 161).
F 789	VcoreFailSlv2	3	Processor voltage in the device at L3 (slave 2) is incorrect.	
W 791	RsDspSlv1	1	Reset of the signal processor in the device at L2 (slave 1) has been identified.	<ul style="list-style-type: none"> Contact the Service (see Section 16 "Contact", page 161).
W 792	RsDspSlv2	1	Reset of the signal processor in the device at L3 (slave 2) has been identified.	
W 794	TimeOutDspSlv1	1	Timeout of the signal processor in the device at L2 (slave 1)	<ul style="list-style-type: none"> Contact the Service (see Section 16 "Contact", page 161).
W 795	TimeOutDspSlv2	1	Timeout of the signal processor in the device at L3 (slave 2)	
W 797	AiVtgMonFailSlv1	1	Non-compliance of monitoring times (islanding detection) and external grid voltage in the device at L2 (slave 1)	<ul style="list-style-type: none"> Contact the Service (see Section 16 "Contact", page 161).
W 798	AiVtgMonFailSlv2	1	Non-compliance of monitoring times (islanding detection) and external grid voltage in the device at L3 (slave 2)	

10.5.8 External Device and Component Category (8xx)

No.	Name	Level	Cause	Corrective measures
F 801	Box	4	Plausibility check on the contactors in the Multicluster-Box has failed.	<ul style="list-style-type: none"> Contact the Service (see Section 16 "Contact", page 161).

No.	Name	Level	Cause	Corrective measures
W 805	BoxNoGn	1	Generator operation not possible	<p>⚠ QUALIFIED PERSON</p> <ul style="list-style-type: none"> Reset the off-grid system. For this, disconnect all loads, AC sources, generator and DC sources. Open the load-break switch of the BatFuse. Wait ten minutes and restart the off-grid system. Wait until all AC sources are feeding into the stand-alone grid and all loads are connected before connecting the generator. Contact the Service (see Section 16 "Contact", page 161).
F 806	BoxType	4	<p>Box coding conflicts with software settings: Configuration of the Sunny Island inverters does not match the Multicluster-Box.</p>	<p>⚠ QUALIFIED PERSON</p> <ul style="list-style-type: none"> Check whether the value of the parameter 250.23 Box matches the Multicluster-Box. If the value does not match, restart the QCG (see the Sunny Island inverter installation manual). Contact the Service (see Section 16 "Contact", page 161).
W 807	BoxGdVtg	1	Voltage of the external energy source is not within the valid thresholds for connection.	<ul style="list-style-type: none"> Acknowledge the error (see Section 10.3, page 47). Contact the Service (see Section 16 "Contact", page 161).
F 809	BoxNoLod	4	<p>Error Q10 contactor: Load-shedding contactor Q10 in the Multicluster-Box is not functioning correctly.</p> <p>Exception: Load-shedding contactor Q110 in the Multicluster-Box 12 (MC-BOX-12.3-20) is not functioning correctly.</p>	<ul style="list-style-type: none"> Reset the off-grid system. For this, disconnect the off-grid system and restart. <p>The configuration may be incorrect.</p> <p>⚠ QUALIFIED PERSON</p> <ul style="list-style-type: none"> Start the QCG and reconfigure multicluster operation (see the Sunny Island inverter installation manual). Contact the Service (see Section 16 "Contact", page 161).
F 810	Box15V	4	<p>Error in the 15 V voltage supply of the MCBUBox: 15 V voltage supply in the Multicluster-Box is defective.</p>	<ul style="list-style-type: none"> Contact the Service (see Section 16 "Contact", page 161).

No.	Name	Level	Cause	Corrective measures
F 811	Box24V	4	Error in the 24 V voltage supply of the MCBUBox: 24 V voltage supply in the Multicluster-Box is defective.	<ul style="list-style-type: none"> Contact the Service (see Section 16 "Contact", page 161).
W 815	BoxQ5	1	Error Q5 contactor: Contactor Q5 in the Multicluster-Box is not functioning correctly. Exception: Load-shedding contactor Q105 in the Multicluster-Box 12 (MC-BOX-12.3-20) is not functioning correctly.	<ul style="list-style-type: none"> Reset the off-grid system. For this, disconnect the off-grid system and restart. <p>The configuration may be incorrect.</p> <p>⚠ QUALIFIED PERSON</p> <ul style="list-style-type: none"> Start the QCG and reconfigure multicluster operation (see the Sunny Island inverter installation manual).
F 816	BoxQ7	2	Error Q7 contactor: Contactor Q7 in the Multicluster-Box is not functioning correctly.	<ul style="list-style-type: none"> Contact the Service (see Section 16 "Contact", page 161).
F 817	BoxQ9	4	Error Q9 contactor: Contactor Q9 in the Multicluster-Box is not functioning correctly. Exception: Load-shedding contactor Q109 in the Multicluster-Box 12 (MC-BOX-12.3-20) is not functioning correctly.	<ul style="list-style-type: none"> Contact the Service (see Section 16 "Contact", page 161).
F 818	BoxPhsFail	4	Box phase missing: One line conductor of a Sunny Island inverter is missing.	<ul style="list-style-type: none"> Ensure that all circuit breakers of the Sunny Island inverters in the Multicluster-Box are closed. <p>⚠ QUALIFIED PERSON</p> <ol style="list-style-type: none"> Search for the missing line conductor and eliminate the error. For this, with loads connected, measure the AC voltage between each line conductor and between the line conductors and the neutral conductors. If an AC voltage deviates from the nominal voltage by $\pm 10\%$, the corresponding line conductor is missing. Reset the off-grid system. For this, disconnect the off-grid system and restart.
W 824	BoxQ4Overload	1	Multicluster-Box signals an error at contactor Q4 .	<ul style="list-style-type: none"> Contact the Service (see Section 16 "Contact", page 161).
F 830	BoxQ2NotOpen	2	Error: Contactor Q2 does not open Exception: In the NA-Box, the tie switch Q202 does not open.	<ul style="list-style-type: none"> Contact the Service (see Section 16 "Contact", page 161).

No.	Name	Level	Cause	Corrective measures
F 831	BoxQ2NotClose	2	Error: Contactor Q2 does not close Exception: In the NA-Box, the tie switch Q202 does not close.	<ul style="list-style-type: none"> Contact the Service (see Section 16 "Contact", page 161).
F 832	BoxQ9NotOpen	2	Error: Contactor Q9 does not open Exception: Load-shedding contactor Q109 in the Multicluster-Box 12 (MC-BOX-12.3-20) does not open.	<ul style="list-style-type: none"> Contact the Service (see Section 16 "Contact", page 161).
F 833	BoxQ9NotClose	2	Error: Contactor Q9 does not close Exception: Load-shedding contactor Q109 in the Multicluster-Box 12 (MC-BOX-12.3-20) does not close.	<ul style="list-style-type: none"> Contact the Service (see Section 16 "Contact", page 161).
F 834	BoxQ10NotOpen	4	Error: Contactor Q10 does not open Exception: Load-shedding contactor Q110 in the Multicluster-Box 12 (MC-BOX-12.3-20) does not open.	<ul style="list-style-type: none"> Contact the Service (see Section 16 "Contact", page 161).
F 835	BoxQ10NotClose	4	Error: Contactor Q10 does not close Exception: Load-shedding contactor Q110 in the Multicluster-Box 12 (MC-BOX-12.3-20) does not close.	<ul style="list-style-type: none"> Contact the Service (see Section 16 "Contact", page 161).
W 840	eHZ1ComFail	1	Faulty communication with the PV production meter	<ul style="list-style-type: none"> Ensure that the optical probe is correctly installed and connected.
W 841	eHZ2ComFail	1	Faulty communication with the feed-in meter and purchased electricity meter	
W 842	ComBoxFail	1	Communication between device and SBUKomBox (Meter Box) is faulty	<div style="background-color: #cccccc; padding: 2px;">⚠ QUALIFIED PERSON</div> <ul style="list-style-type: none"> Ensure that the data cables are correctly installed.

No.	Name	Level	Cause	Corrective measures
W 843	ComBoxWD	1	The SBUKomBox (Meter Box) watchdog has triggered.	<ul style="list-style-type: none"> Contact the Service (see Section 16 "Contact", page 161).
W 844	eHZ1ProtFail	1	Unsupported protocol detected on eHZ 1 (feed-in & purchased electricity meter)	
W 845	eHZ2ProtFail	1	Unsupported protocol detected on eHZ 2 (PV production meter)	
W 846	eHzInFail	1	Reading heads of the eHZ interchanged in the input of the SBUKomBox (Meter Box).	<ul style="list-style-type: none"> Swap the optical probe connections.
W 847	ComHMFail	1	CAN communication with energy meter is faulty.	<p>⚠ QUALIFIED PERSON</p> <ul style="list-style-type: none"> Ensure that the data cables are correctly installed. Ensure that the parameter 250.06 ComBaud is set to 115k Bd.
W 848	PhsMtrComFail	1	Faulty communication between the Sunny Island and the SMA Energy Meter: Electric power per line conductor is not available.	<p>⚠ QUALIFIED PERSON</p> <ul style="list-style-type: none"> Ensure that the data cables are correctly installed. Ensure that the current firmware version of the SMA Speedwire data module is installed.
W 851	Sic1BatShort	1	Battery reversely connected or short circuit on PV charge controller 1: Connection of the battery to the Sunny Island Charger 1 is reverse-poled or there is a short circuit.	<p>⚠ QUALIFIED PERSON</p> <ul style="list-style-type: none"> Ensure that the battery is correctly connected to the DC connection of the Sunny Island Charger charge controller. Disconnect the PV array from the Sunny Island Charger and restart the system. This will ensure that the PV array is not short-circuited.
W 852	Sic1BatVtgHi	1	PV charge controller 1 battery overvoltage: Battery voltage at the Sunny Island Charger 1 is too high.	<p>⚠ QUALIFIED PERSON</p> <ol style="list-style-type: none"> Ensure that the configuration of the Sunny Island Charger charge controller with the DIP switches is correct. Ensure that all DC sources and DC loads are correctly configured and connected. Reset the off-grid system. Disconnect the off-grid system, wait ten minutes and restart.

No.	Name	Level	Cause	Corrective measures
W 853	Sic1PvVtgHi	1	PV charge controller 1 PV generator overvoltage: PV voltage at the Sunny Island Charger 1 is too high.	<ul style="list-style-type: none"> Contact the Service, if required (see Section 16 "Contact", page 161).
W 854	Sic1PvVtgLo	1	No PV voltage or short circuit on PV charge controller 1: No PV voltage at the Sunny Island Charger 1 or there is a short circuit.	<ul style="list-style-type: none"> Contact the Service, if required (see Section 16 "Contact", page 161).
W 855	Sic1TmpLo	1	Sensor error (or undertemperature) for the PV charge controller 1 charger temperature: Sunny Island Charger 1 reports battery undertemperature.	<p>⚠ QUALIFIED PERSON</p> <ul style="list-style-type: none"> Set the Sunny Island Charger to the operating mode "SMA operation" (see the Sunny Island Charger charge controller installation manual).
W 856	Sic1TmpHI	1	PV charge controller 1 device overtemperature: Sunny Island Charger 1 reports battery overtemperature.	<ul style="list-style-type: none"> Ensure that the configuration of the Sunny Island Charger charge controller with the DIP switches is correct. Ensure that the communication interfaces are correctly inserted in the Sunny Island.
W 857	Sic1ComLoss	1	No communication with DC charger for more than 24 h – PV charge controller 1: Last communication with the Sunny Island Charger 1 was more than 24 hours ago.	<p>⚠ QUALIFIED PERSON</p> <ul style="list-style-type: none"> Ensure that undamaged CAT5e cables are used for communication and that the cables are plugged in correctly. Ensure that the configuration of the Sunny Island Charger charge controller with the DIP switches is correct. Ensure that the communication interfaces are correctly inserted in the Sunny Island.
W 861	Sic2BatShort	1	Battery reversely connected or short circuit on PV charge controller 2: Connection of the battery to the Sunny Island Charger 2 is reverse-poled or there is a short circuit.	<p>⚠ QUALIFIED PERSON</p> <ul style="list-style-type: none"> Ensure that the battery is correctly connected to the DC connection of the Sunny Island Charger charge controller. Disconnect the PV array from the Sunny Island Charger and restart the system. This will ensure that the PV array is not short-circuited.

No.	Name	Level	Cause	Corrective measures
W 862	Sic2BatVtgHi	1	PV charge controller 2 battery overvoltage: Battery voltage at the Sunny Island Charger 2 is too high.	<ul style="list-style-type: none"> Reset the system. For this, switch off the system, wait ten minutes and restart. <p>⚠ QUALIFIED PERSON</p> <ul style="list-style-type: none"> Ensure that the configuration of the Sunny Island Charger charge controller with the DIP switches is correct. Ensure that all DC sources and DC loads are correctly configured and connected.
W 863	Sic2PvVtgHi	1	PV charge controller 2 PV generator overvoltage: PV voltage at the Sunny Island Charger 2 is too high.	<ul style="list-style-type: none"> Contact the Service, if required (see Section 16 "Contact", page 161).
W 864	Sic2PvVtgLo	1	No PV voltage or short circuit on PV charge controller 2: No PV voltage at the Sunny Island Charger 2 or there is a short circuit.	<ul style="list-style-type: none"> Contact the Service, if required (see Section 16 "Contact", page 161).
W 865	Sic2TmpLo	1	Sensor error (or undertemperature) for the PV charge controller 2 charger temperature: Sunny Island Charger 2 reports battery undertemperature.	<p>⚠ QUALIFIED PERSON</p> <ul style="list-style-type: none"> Set the Sunny Island Charger to the operating mode "SMA operation" (see the Sunny Island Charger charge controller installation manual).
W 866	Sic2TmpHI	1	PV charge controller 2 device overtemperature: Sunny Island Charger 2 reports battery overtemperature.	
W 867	Sic2ComLoss	1	No communication with DC charger for more than 24 h – PV charge controller 2: Last communication with the Sunny Island Charger 2 was more than 24 hours ago.	<p>⚠ QUALIFIED PERSON</p> <ul style="list-style-type: none"> Ensure that undamaged CAT5e cables are used for communication and that the cables are plugged in correctly. Ensure that the configuration of the Sunny Island Charger charge controller with the DIP switches is correct. Ensure that the communication interfaces are correctly inserted in the Sunny Island.

No.	Name	Level	Cause	Corrective measures
W 871	Sic2BatShort	1	Battery reversely connected or short circuit on PV charge controller 3: Connection of the battery to the Sunny Island Charger 2 is reverse-poled or there is a short circuit.	<p>⚠ QUALIFIED PERSON</p> <ul style="list-style-type: none"> • Ensure that the battery is correctly connected to the DC connection of the Sunny Island Charger charge controller. • Disconnect the PV array from the Sunny Island Charger and restart the system. This will ensure that the PV array is not short-circuited.
W 872	Sic3BatVtgHi	1	PV charge controller 3 battery overvoltage: Battery voltage at the Sunny Island Charger 3 is too high.	<p>⚠ QUALIFIED PERSON</p> <ol style="list-style-type: none"> 1. Ensure that the battery is correctly connected to the DC connection of the Sunny Island Charger charge controller. 2. Disconnect the PV array from the Sunny Island Charger and restart the system. This will ensure that the PV array is not short-circuited. 3. Reset the system. For this, switch off the system, wait ten minutes and restart.
W 873	Sic3PvVtgHi	1	PV charge controller 3 PV generator overvoltage: PV voltage at the Sunny Island Charger 3 is too high.	<ul style="list-style-type: none"> • Contact the Service, if required (see Section 16 "Contact", page 161).
W 874	Sic3PvVtgLo	1	No PV voltage or short circuit on PV charge controller 3: No PV voltage at the Sunny Island Charger 3 or there is a short circuit.	
W 875	Sic3TmpLo	1	Sensor error (or undertemperature) for the PV charge controller 3 charger temperature: Sunny Island Charger 3 reports battery undertemperature.	<p>⚠ QUALIFIED PERSON</p> <ul style="list-style-type: none"> • Set the Sunny Island Charger to the operating mode "SMA operation" (see the Sunny Island Charger charge controller installation manual).
W 876	Sic3TmpHI	1	PV charge controller 3 device overtemperature: Sunny Island Charger 3 reports battery overtemperature.	

No.	Name	Level	Cause	Corrective measures
W 877	Sic3ComLoss	1	No communication with DC charger for more than 24 h – PV charge controller 3: Last communication with the charge controller 3 was more than 24 hours ago.	<p>⚠ QUALIFIED PERSON</p> <ul style="list-style-type: none"> • Ensure that undamaged CAT5e cables are used for communication and that the cables are plugged in correctly. • Ensure that the configuration of the Sunny Island Charger charge controller with the DIP switches is correct. • Ensure that the communication interfaces are correctly inserted in the Sunny Island.
W 881	Sic4BatShort	1	Battery reversely connected or short circuit on PV charge controller 4: Connection of the battery to the Sunny Island Charger 4 is reverse-poled or there is a short circuit.	<p>⚠ QUALIFIED PERSON</p> <ul style="list-style-type: none"> • Ensure that the battery is correctly connected to the DC connection of the Sunny Island Charger charge controller. • Disconnect the PV array from the Sunny Island Charger and restart the system. This will ensure that the PV array is not short-circuited.
W 882	Sic4BatVtgHi	1	PV charge controller 4 battery overvoltage: Battery voltage at the Sunny Island Charger 4 is too high.	<p>⚠ QUALIFIED PERSON</p> <ol style="list-style-type: none"> 1. Ensure that the configuration of the Sunny Island Charger charge controller with the DIP switches is correct. 2. Ensure that all DC sources and DC loads are correctly configured and connected. 3. Reset the system. For this, switch off the system, wait ten minutes and restart.
W 883	Sic4PvVtgHi	1	PV charge controller 4 PV generator overvoltage: PV voltage at the Sunny Island Charger 4 is too high.	<ul style="list-style-type: none"> • Contact the Service, if required (see Section 16 "Contact", page 161).
W 884	Sic4PvVtgLo	1	No PV voltage or short circuit on PV charge controller 4: No PV voltage at the Sunny Island Charger 4 or there is a short circuit.	

No.	Name	Level	Cause	Corrective measures
W 885	Sic4TmpLo	1	Sensor error (or undertemperature) for the PV charge controller 4 charger temperature: Sunny Island Charger 4 reports battery undertemperature.	<p>⚠ QUALIFIED PERSON</p> <ul style="list-style-type: none"> Set the Sunny Island Charger to the operating mode "SMA operation" (see the Sunny Island Charger charge controller installation manual).
W 886	Sic4TmpHI	1	PV charge controller 4 device overtemperature: Sunny Island Charger 4 reports battery overtemperature.	
W 887	Sic4ComLoss	1	No communication with DC charger for more than 24 h – PV charge controller 4: Last communication with the Sunny Island Charger 4 was more than 24 hours ago.	<p>⚠ QUALIFIED PERSON</p> <ul style="list-style-type: none"> Ensure that undamaged CAT5e cables are used for communication and that the cables are plugged in correctly. Ensure that the configuration of the Sunny Island Charger charge controller with the DIP switches is correct. Ensure that the communication interfaces are correctly inserted in the Sunny Island.
W 890	BoxMeas	2	Voltage or current measurement interferences at external measurement point of the AC sub-distribution (Multicluster-Box) at line conductor L1 (Master)	<p>⚠ QUALIFIED PERSON</p> <ul style="list-style-type: none"> Ensure that the control and measuring cable between the Multicluster-Box and the corresponding Sunny Island of the main cluster is correctly inserted. When doing so, observe the correct sequence of the Multicluster-Box connections to the Sunny Island inverters (see the Sunny Island inverter installation manual and the Multicluster-Box documentation).
W 891	BoxMeasSlv1	2	Voltage or current measurement interferences at external measurement point of the AC sub-distribution (Multicluster-Box) at line conductor L2 (slave 1)	
W 892	BoxMeasSlv2	2	Voltage or current measurement interferences at external measurement point of the AC sub-distribution (Multicluster-Box) at line conductor L3 (slave 2)	
F 894	BoxQ10LdScFail	4	Q10 error: The voltage supply of Q10/Q110 fails due to a short circuit in the stand-alone grid.	<p>⚠ QUALIFIED PERSON</p> <ul style="list-style-type: none"> Eliminate the short circuit.

10.5.9 General Category (9xx)

No.	Name	Level	Cause	Corrective measures
F 905	CalFail	4	The calibration data cannot be read or was not completely transferred from the device at L1 (Master).	<ul style="list-style-type: none"> Contact the Service (see Section 16, page 161).
F 906	CalFailSlv1	4	The calibration data cannot be read or was not completely transferred from the device at L2 (slave 1).	
F 907	CalFailSlv2	4	The calibration data cannot be read or was not completely transferred from the device at L3 (slave 2).	
W 909	McExtnClstFwDif	1	At least one extension cluster has another firmware version than the main cluster.	Update the firmware (see Section 7.3, page 40).
F 910	McEClstCntyDif	3	At least in one extension cluster, the Sunny Islands are set to another country standard than the Sunny Islands in the main cluster.	<div style="background-color: #cccccc; padding: 2px;">⚠ QUALIFIED PERSON</div> <ul style="list-style-type: none"> Set the same country standard on all Sunny Island inverters in the main and extension cluster (parameter 232.01 Country).
W 915	Timeout	1	Watchdog OCU: An error has occurred in the program run sequence.	<ul style="list-style-type: none"> Contact the Service (see Section 16, page 161).
F 920	XA01General	3	Error message via SiCom: General	<ul style="list-style-type: none"> Eliminating the error cause in the external battery management system (see battery manufacturer's documentation).
F 921	XA02DcHiVolt	3	Error message via SiCom: Battery overvoltage	
F 922	XA03DcLoVolt	3	Error message via SiCom: Battery undervoltage	<ul style="list-style-type: none"> Eliminating the error cause in the external battery management system (see battery manufacturer's documentation).
F 923	XA04DcHiTmp	3	Error message via SiCom: Battery overtemperature	
F 924	XA05DcLoTmp	3	Error message via SiCom: Battery undertemperature	<ul style="list-style-type: none"> Eliminating the error cause in the external battery management system (see battery manufacturer's documentation).
F 925	XA06DcHiTmpC	3	Error message via SiCom: Battery overtemperature in charge mode	
F 926	XA07DcLoTmpC	3	Error message via SiCom: battery undertemperature in charge mode	

No.	Name	Level	Cause	Corrective measures
F 927	XA08DcHiCur	3	Error message via SiCom: battery charging current too high	<ul style="list-style-type: none"> Eliminating the error cause in the external battery management system (see battery manufacturer's documentation).
F 928	XA09DcHiChgCur	3	Error message via SiCom: Battery charging current in charge mode too high	
F 929	XA10Contact	3	Error message via SiCom: Error in the battery	<ul style="list-style-type: none"> Eliminating the error cause in the external battery management system (see battery manufacturer's documentation).
F 930	XA11Short	3	Error message via SiCom: Short circuit	<ul style="list-style-type: none"> Eliminating the error cause in the external battery management system (see battery manufacturer's documentation).
F 931	XA12Bms	3	Error message via SiCom: Internal error in battery management	<ul style="list-style-type: none"> Eliminating the error cause in the external battery management system (see battery manufacturer's documentation).
F 932	XA13CellBal	3	Error message via SiCom: Different state of charge of the battery cells	<ul style="list-style-type: none"> Eliminating the error cause in the external battery management system (see battery manufacturer's documentation).
F 933	XA14PackBal	3	Error message via SiCom: Reserved	<ul style="list-style-type: none"> Eliminating the error cause in the external battery management system (see battery manufacturer's documentation).
F 935	XA16Generator	3	Error message via SiCom: Error in the generator	<ul style="list-style-type: none"> Eliminating the error cause in the external battery management system (see battery manufacturer's documentation).
W 936	XW01General	1	Warning via SiCom: General	<ul style="list-style-type: none"> Eliminating the error cause in the external battery management system (see battery manufacturer's documentation).
W 937	XW02DcHiVolt	1	Warning via SiCom: Battery overvoltage	<ul style="list-style-type: none"> Eliminating the error cause in the external battery management system (see battery manufacturer's documentation).
W 938	XW03DcLoVolt	1	Warning via SiCom: Battery undervoltage	
W 939	XW04DcHiTmp	1	Warning via SiCom: Battery overtemperature	<ul style="list-style-type: none"> Eliminating the error cause in the external battery management system (see battery manufacturer's documentation).
W 940	XW05DcLoTmp	1	Warning via SiCom: Battery undertemperature	

No.	Name	Level	Cause	Corrective measures
W 941	XW06DcHiTmpC	1	Warning via SiCom: Battery overtemperature in charge mode	<ul style="list-style-type: none"> Eliminating the error cause in the external battery management system (see battery manufacturer's documentation).
W 942	XA07DcLoTmpC	1	Warning via SiCom: Battery undertemperature in charge mode	
W 943	XW08DcHiCur	1	Warning via SiCom: battery charging current too high	<ul style="list-style-type: none"> Eliminating the error cause in the external battery management system (see battery manufacturer's documentation).
W 944	Warning via SiCom: battery charging current in charge mode too high	1	Warning via SiCom: battery charging current in charge mode too high	
W 945	XW10Contact	1	Warning via SiCom: error in the battery	<ul style="list-style-type: none"> Eliminating the error cause in the external battery management system (see battery manufacturer's documentation).
W 946	XW11Short	1	Warning via SiCom: short circuit	<ul style="list-style-type: none"> Eliminating the error cause in the external battery management system (see battery manufacturer's documentation).
W 947	XW12Bms	1	Warning via SiCom: internal error in battery management	<ul style="list-style-type: none"> Eliminating the error cause in the external battery management system (see battery manufacturer's documentation).
W 948	XW13CellBal	1	Warning via SiCom: different state of charge of the battery cells	<ul style="list-style-type: none"> Eliminating the error cause in the external battery management system (see battery manufacturer's documentation).
w 949	XW14PackBal	1	Warning via SiCom: Reserved	<ul style="list-style-type: none"> Eliminating the error cause in the external battery management system (see battery manufacturer's documentation).
W 951	XW16Generator	1	Warning via SiCom: Error in the generator	<ul style="list-style-type: none"> Eliminating the error cause in the external battery management system (see battery manufacturer's documentation).
F 952	ExtBMSTimeout	3	The timeout monitoring system of the battery management has triggered	<ul style="list-style-type: none"> Ensure that the data cable of the external lithium-ion battery is connected correctly.
W 953	WrnExtBMSTmOut	1	The timeout monitoring system of the battery management has triggered	<ul style="list-style-type: none"> Ensure that the terminators of the CAN bus in the communication bus are attached.

10.6 Frequently Asked Questions (FAQs)

10.6.1 Questions Regarding the Sunny Island

Why is the Sunny Island not switching off even though I have opened the load-break switch of the BatFuse?

The Sunny Island may still be supplied from the AC side.

⚠ QUALIFIED PERSON

- Switch off all AC sources and disconnect them from the Sunny Island.

Why is the Sunny Island not switching to energy-saving mode?

Another function might have a higher priority than energy saving mode, e.g., equalization charge or full charge.

After automatic disconnection in battery protection mode, the Sunny Island can no longer be started?

⚠ QUALIFIED PERSON

- Charge the battery only when the Sunny Island cannot be switched on (see Section 10.7 "Charging the Battery After Automatic Shutdown in Off-Grid Systems (Emergency Charge Mode)", page 89).
 - Switch off all loads.
 - If there is a generator in the system, start the generator manually. When doing so, observe the warm-up time of the generator. Five minutes without charge current can result in disconnection of the Sunny Island inverter.
 - If sufficient power is available from the generator or the AC sources in the stand-alone grid, e.g., sufficient solar irradiation for PV inverters, switch the Sunny Island on. AC sources in the stand-alone grid can start feeding in electric current only once the Sunny Island has been started and is in operation.

10.6.2 Questions Regarding the Sunny Remote Control

The display of the Sunny Remote Control is dark and nothing is displayed – why?

The Sunny Island might not be switched on.

- Ensure that the fuse in the BatFuse is not defective and switch on the Sunny Island (see Section 4.1, page 20) .

The Sunny Remote Control might not be connected to the Sunny Island.

⚠ QUALIFIED PERSON

- Ensure that the Sunny Remote Control is connected to the Sunny Island.

The RJ45 data cable may be damaged.

⚠ QUALIFIED PERSON

- Replace the RJ45 data cable between the Sunny Remote Control and the Sunny Island.

Why can parameters not be changed?

It is possible that the parameter is displayed only in expert mode.

- Switch to expert mode on the Sunny Remote Control (see Section 5.4.1, page 32).

It might be possible to change the parameter only in standby mode or in the QCG.

- Observe the messages in the display (see Section 5.4.6, page 34).

The parameter may be hidden as it is not required in the configuration set for the system.

- Ensure that the configuration does not deactivate any functions which are required.

Why is "MMC/SD operation failed!" shown on the display?

An action with the SD memory card has failed.

- Use a computer to ensure that the SD memory card is free of errors.

⚠ QUALIFIED PERSON

- Ensure that the data cable between the Sunny Remote Control and the Sunny Island is undamaged and that the plugs are firmly inserted into the pin connectors.

Why is the display showing "WRONG FILE SYSTEM"?

The SD memory card is not formatted with the FAT-16 or FAT-32 file system.

10.6.3 Questions Regarding the Battery

What happens if a battery is defective?

⚠ QUALIFIED PERSON

- Remove the defective battery cell from the battery system. This reduces the rated voltage of the battery by the voltage of the battery cell.
- In the QCG, set the current rated voltage of the battery under **New Battery** (see Section 11.8 "Replacing the Battery", page 97).

Why is the SOC of the battery not 100% after completion of full charge?

The power requirements of the loads might have been so high before completion of the full charge that the battery could not be charged to 100 percent.

- If necessary, select the parameter **222.03 AptmFul** and set to a longer time period.

Why is the battery discharging even though the generator is running?

The Sunny Island may not have connected to the generator.

- Eliminate the cause (see Section 10.6.4 "Questions Regarding the Generator", page 87).

The power of the loads might exceed the power of the generator.

What do you need to do after replacing a battery current sensor?

⚠ QUALIFIED PERSON

- Calibrate the battery current sensor (see the Commissioning section in the Sunny Island inverter installation manual).

10.6.4 Questions Regarding the Generator

Why is the Sunny Island not connecting to the running generator?

A high output power of the Sunny Island inverter when the battery state of charge is low may lead to the Sunny Island not being able to raise the AC voltage in the stand-alone grid to the AC voltage of the generator. The Sunny Island cancels the synchronization.

- To charge the battery, reduce the power of the loads.

The generator voltage might not be within the thresholds for voltage and frequency.

- Check whether the symbol * is displayed permanently in standard mode.

If the * symbol is not displayed, ensure that the fuse is not defective or the circuit breaker is activated.

If the * symbol is not displayed permanently, the generator voltage is sporadically outside the thresholds.

- Set the thresholds for voltage and frequency of the generator voltage (see the Sunny Island inverter installation manual).

If the * symbol is displayed permanently, the Sunny Island is in the warm-up period or is blocked for connection.
Useful hint: Tip: Check whether the Sunny Remote Control displays the "!" warning symbol in standard mode.

Why does the Sunny Island connect to the generator for only a short time?

The generator may be overloaded.

- Select the parameter **234.03 GnCurNom** and set it to 75% of the rated current of the generator.
- If possible, reduce the power of the loads.

The maximum permissible generator voltage may be set too low.

⚠ QUALIFIED PERSON

- Select the parameter **234.02 GnVtgMax** and set to the maximum generator voltage.

The minimum frequency for the generator voltage may be set too high.

⚠ QUALIFIED PERSON

- Select the parameter **234.05 GnFrqMin** and set to the minimum frequency of the generator voltage.

The permitted time **234.14 GnRvTm** for reverse power might have been exceeded.

- Check whether warning **W401** is registered in the menu **420# Error history**.
Useful hint: Tip: If a warning was registered, the warning symbol "!" is shown in the standard mode of the Sunny Remote Control.
- Select the **540.02 GnAck** parameter and set to **Ackn**. This acknowledges the generator error.

The Sunny Island does not reconnect to the generator after disconnection from the generator due to non-compliance with the thresholds for voltage and frequency – why?

The Sunny Island is switched with a hysteresis, i.e., the thresholds for connection do not correspond to the thresholds for disconnection.

- To unload the generator, disconnect unnecessary loads.
- Wait until the voltage and frequency have reached the nominal values.

10.6.5 Questions Regarding Multicluster Systems

Extension clusters remain in standby mode even though the main cluster is in inverter mode?

The data cable between the masters of the individual clusters might not be connected. The master of the main cluster cannot forward the "Start" command to the masters of the extension clusters.

Why is the multicluster system not supplying full power?

An extension cluster or individual Sunny Island inverters of an extension cluster might have failed.

Why are high levels of energy being transferred between the clusters in the multicluster system?

The state of charge of the batteries might differ temporarily. The off-grid system equalizes different states of charge automatically.

The nominal frequencies and nominal voltages may be defined differently.

- Set the frequencies and voltages in the **210# Inverter Settings** menu to the same values for all masters.

The battery capacities might differ significantly.

⚠ QUALIFIED PERSON

- Distribute the battery capacities to the clusters as evenly as possible.

Individual battery cells of a battery might have failed.

⚠ QUALIFIED PERSON

- Disconnect defective battery cells and set the new rated voltage and capacity (see Section 11.8 "Replacing the Battery", page 97).

10.7 Charging the Battery After Automatic Shutdown in Off-Grid Systems (Emergency Charge Mode)

When a battery undergoes deep discharge, the Sunny Island shuts down automatically and you cannot restart the Sunny Island. In order to start the Sunny Island again after an automatic shutdown, you must charge the battery in emergency charge mode.

In emergency charge mode, the Sunny Island does not form a separate stand-alone grid, and you can charge the battery using a generator. Battery management is active in emergency charge mode and the Sunny Island charges the battery in accordance with the parameter settings. In standby mode or in the QCG, you can adjust the parameters for the battery, e.g., the battery nominal voltage, if a battery cell fails.

⚠ WARNING

Danger to life due to fire or explosion when charging a deep discharged lithium-ion battery.

The charging of a deep discharged lithium-ion battery can lead to its destruction. Death or lethal injuries can result.

- Verify that the lithium-ion battery is not deep discharged (see manual of the lithium-ion battery)
- Charging is performed in accordance with the specifications of the battery manufacturer (see manual of the lithium-ion battery).
- Only run the emergency charge mode with Sunny Island after approval by the battery manufacturer.

⚠ WARNING

Danger to life from electric shock due to high voltages

High voltages are present inside the Sunny Island. When the enclosure lid is removed, live components can be touched that can result in death or serious injury due to electric shock.

- Disconnect the Sunny Island from voltage sources (see Section 9, page 45).

i Restricted management functions in emergency charge mode

In emergency charge mode, the generator management is not active. The limits for voltage, current and frequency are not monitored. Set the maximum current consumption of the Sunny Island inverter for charging the battery in emergency charge mode. The Sunny Island does not record additional strain on the generator due to loads.

Requirements:

- The Sunny Remote Control must be connected to the master.
- The system must be an off-grid system.
- The system must be a single system (single-phase system with Sunny Island).
- Lead-acid batteries must be connected (for emergency charge mode of a lithium-ion battery see documentation of the battery manufacturer).

Procedure:

- Connect the generator to connection **AC1**.
- Charge the battery.
- Disconnect the generator from connection **AC1**.
- Start the off-grid system.

Connecting the Generator to Connection AC1

1. Disconnect the Sunny Island from voltage sources (see Section 9, page 45).
2. If the system is a single-cluster system (single-phase or three-phase), the master must temporarily be connected as single system (see quick reference guide "Off-Grid Systems" of the Sunny Island inverter).
3. If the system is a multicluster system (single-phase or three-phase), the master of the main cluster must temporarily be connected as single system (see quick reference guide "Off-Grid Systems" of the Sunny Island inverter).
4. If a generator is installed permanently in the off-grid system, bridge the connections **AC1** and **AC2**.
5. If a mobile generator is used, connect the generator to connection **AC1** (see the Sunny Island inverter installation manual).

Close the Sunny Island (see commissioning section in the Sunny Island inverter installation manual).

Charging the Battery

1. Switch off all loads.
2. Connect or close all circuit breakers and fuse switch-disconnectors for energy sources.
3. Quickly close the load-break switch of the BatFuse and close the BatFuse (see BatFuse installation manual).
4. Start the generator.
5. Switch the Sunny Island on (see Section 4.1, page 20).
6. If the Sunny Remote Control displays **<Init System>** [#], press and hold the button.
 - The Sunny Remote Control displays the QCG.

```
Select option
001#01 <00#000000>
      StartMenu
      New System#
```

7. Select the menu **Emerg Charge** and press the button.
 - The Sunny Remote Control shows the **ExtCurMax** parameter.

```
Select option
001#01 <00#000000>
      StartMenu
      Emerg Charge#
```

```
Emerg. Charg Mode
005#22 <Set>#
      ExtCurMax
      0.0 [A]
```

8. Confirm with **Y**.
9. Set the AC current of the connected generator and press the button.
10. Confirm the AC current with **Y**.
11. Turn the button to the right and confirm the message **Emerg. Charge Mode Start?**

```
Setup new system
Done ? <accept Y/N>
```

i Interrupting the emergency charge mode

You can interrupt the emergency charge mode, e.g., to add diesel to a generator.

- Press and hold the button.
 - Emergency charge mode is stopped.
- Press and hold the button.
 - Emergency charge mode is in operation.

Disconnecting the generator from connection AC1

1. Switch the Sunny Island off (see Section 4.4 "Switching Off the Sunny Island", page 21).
2. Ensure that the generator is stopped permanently.

3. **⚠ WARNING****Danger to life from electric shock due to high voltages**

High voltages are present on the AC power cables and on the control cables. Touching live components can result in death or serious injury due to electric shock.

- Disconnect the Sunny Island from voltage sources (see Section 9, page 45).

4. If the connections **AC1** and **AC2** are bridged, remove the bridge.
5. If a mobile generator is used, disconnect the generator from connection **AC1**.
6. If the system is a single-cluster system (single-phase or three-phase) or a multicluster system, restore the system-specific connection (see quick reference guide of the used system).
7. Close the Sunny Island (see commissioning section in the Sunny Island inverter installation manual).

Starting the Off-Grid System

1. Connect or close all circuit breakers and fuse-switch-disconnectors.
2. Start the system (see Section 4.2, page 20).

10.8 Changing Slave Addresses in a Cluster

If you want to change slave addresses (e.g., after replacing a Sunny Island inverter), you can assign the slaves a new address using the QCG. Only the address is changed; all other configurations remain as they were, e.g., assignment of the clusters in a multicluster system. When replacing a master, you must reconfigure the cluster (see the quick reference guide for the relevant system for configuring single-cluster operation or multicluster operation).

Requirements:

- All Sunny Island inverters must be switched off.
- A Sunny Remote Control is connected to the master only.

Procedure:

1. Switch the slave on.
2. Switch the master on.
3. When the Sunny Remote Control shows **<Init System>**, press and hold the button on the Sunny Remote Control.
 - An acoustic signal sounds three times and the QCG starts.
4. Select the **NewClstCfg** menu on the Sunny Remote Control and confirm with **Y**.
5. Select number of line conductors in the system:
 - For a single-phase system, set **1Phs** and press the button.
 - For a three-phase system, set **3Phs** and press the button.
6. Confirm the question **Setup new cluster ?** with **Y**.
7. Wait until the inverter LED of slave 1 is flashing and the Sunny Remote Control shows the message **To identify slave1 press Tss on the Slv**.
8. Press the start-stop button on slave 1.

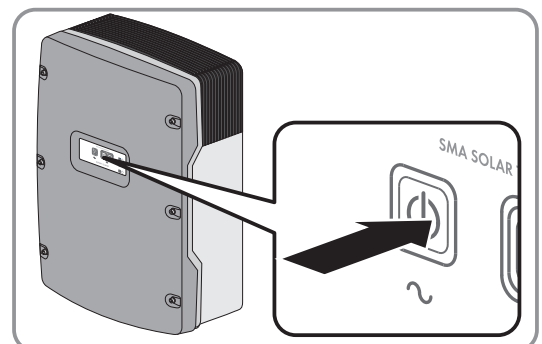

- The QCG configures slave 1.
- 9. To configure slave 2, wait until the inverter LED of slave 2 is flashing and the Sunny Remote Control shows the message **To identify slave2 press Tss on the Slv.**
- 10. Press the start-stop button on slave 2.
 - An acoustic signal sounds and the QCG configures slave 2.
- 11. Press the button on the Sunny Remote Control. This closes the QCG.
 - The Sunny Remote Control switches from display mode to standard mode.

11 Cleaning and Maintenance

11.1 Cleaning and Checking the Sunny Island Inverter Enclosure

NOTICE

Damage to the inverter due to the use of cleaning agents

- If the inverter is dirty, clean the enclosure, the enclosure lid, the type label and the LEDs using only clean water and a cloth.
- Ensure that the inverter is free of dust, foliage and other dirt. Carefully remove heavy dirt with a soft brush.

11.2 Cleaning the Sunny Remote Control

NOTICE

Damage to the Sunny Remote Control due to the use of cleaning agents

- If the Sunny Remote Control is dirty, clean the enclosure, type label, button, and display with a damp cloth only.
- Ensure that the Sunny Remote Control is free of dust, foliage and other dirt.

11.3 Performing a Manual Equalization Charge in the Off-Grid System

After extended periods without charging (e.g., systems operated seasonally), perform a manual equalization charge at the end or start of the season.

Requirement:

- The Sunny Remote Control must be in standard mode or user mode.

Procedure:

1. Select the **Battery** display page on the Sunny Remote Control and press the button (see Section 5.3.2 "Displaying Parameters and Operating and Setting the System", page 30).
2. Select the parameter **Equalize** and set to **Start**.

11.4 Checking the Function

- For the first six months after installation of new systems, check every week whether error messages have been logged. This will reveal any hidden errors in the installation or configuration:
 - Switch to installer mode on the Sunny Remote Control (see Section 5.4.1, page 32).
 - Select the menu **420# Error history** and check whether any error messages have been logged.
 - If error messages have been logged, eliminate the cause (see Section 10 "Troubleshooting", page 46).
- Check every six months whether error messages have been logged:
 - Switch to installer mode on the Sunny Remote Control (see Section 5.4.1, page 32).
 - Select the menu **420# Error history** and check whether any error messages have been logged.
 - If error messages have been logged, eliminate the cause (see Section 10.5 "Logged Warning Messages and Error Messages", page 52).

11.5 Checking the Connections

WARNING

Danger to life from electric shock due to high voltages

High voltages are present inside the Sunny Island. When the enclosure lid is removed, live components can be touched that can result in death or serious injury due to electric shock.

- Disconnect the Sunny Island from voltage sources (see Section 9, page 45).

1. Make sure the Sunny Island is dead. (see Section 9, page 45).
2. Ensure that the cables on the **DC+** and **DC-** connections are securely fastened (torque: 12 Nm).
3. Ensure that the connections are free of corrosion.
4. Ensure that the cables in the **AC1** and **AC2** connections are securely fastened.
5. Close the Sunny Island (see the Sunny Island inverter installation manual).
6. Switch on all load-break switches and circuit breakers.

11.6 Checking and Maintaining the Battery

WARNING

Chemical burns and poisoning due to battery electrolyte

If handled inappropriately, battery electrolyte can cause irritation to the eyes, respiratory system and skin, and it can be toxic. This may result in blindness or serious chemical burns.

- Protect the battery enclosure against destruction.
- Do not open or deform the battery.
- Do not throw batteries into fire. Batteries may explode in fire.
- Whenever working on the battery, wear suitable personal protective equipment such as rubber gloves, an apron, rubber boots and goggles.
- Rinse acid splashes thoroughly for a long time with clear water, and consult a doctor.
- Install, operate, maintain and dispose of the battery according to the manufacturer's specifications.

WARNING

Risk of injury due to short-circuit currents

Short-circuit currents in the battery can cause heat build-up and electric arcs. Burns or eye injuries due to flashes may result.

- Remove watches, rings and other metal objects.
- Use insulated tools.
- Do not place tools or metal parts on the battery.

Requirement:

- The Sunny Remote Control is in user mode.

Procedure:

1. Check whether the current state of the battery corresponds to the expected state:
 - Select the **Battery** display page on the Sunny Remote Control.
 - Select the parameter **Cycle** and compare the value with the expected nominal energy throughputs.

- Select the parameter **Health (SOH)** and compare with the expected usable battery capacity.

If the current state of the battery does not correspond to the expected state, carry out the following steps:

- Ensure that the requirements for the ambient temperature of the battery are met (see documentation of the battery manufacturer).
- Check and optimize the battery management settings.
- If you cannot determine the cause for the deviation, contact the Service (see Section 16 "Contact", page 161)

2. Stop the system and switch off the Sunny Island (see Section 4 "Starting and Stopping the System", page 20).
3. Open the load-break switch of the BatFuse and secure against reconnection.
4. Check and maintain the battery (see documentation of the battery manufacturer).
5. Quickly close the load-break switch of the BatFuse and close the BatFuse (see BatFuse installation manual).
6. Start the system.

11.7 Cleaning the Fans

If the Sunny Remote Control shows the warning **W137 Derate** exceptionally often, one of the fans is probably defective or blocked.

Procedure:

- Clean the ventilation grids.
- Clean the fans.

Cleaning the Ventilation Grids

Proceed as follows to clean each ventilation grid.

Procedure:

1. Remove the ventilation grid laterally.
2.

NOTICE

Damage to the inverter due to foreign bodies

- Do not remove the ventilation grid permanently, otherwise foreign bodies could penetrate the enclosure.
3. Clean the ventilation grid with a soft brush, a paint brush, or compressed air.
 4. Close the recessed grips with the ventilation grids. Ensure that the assignment is correct. The correct assignment is marked on the inside of each ventilation grid: **links/left** for the left-hand side and **rechts/right** for the right-hand side.

Cleaning the Fans

Proceed as follows to clean each fan.

WARNING

Danger to life from electric shock due to high voltages

High voltages are present inside the Sunny Island. When the enclosure lid is removed, live components can be touched that can result in death or serious injury due to electric shock.

- Disconnect the Sunny Island from voltage sources (see Section 9, page 45).

1. Disconnect the Sunny Island from voltage sources (see Section 9, page 45).
2. Wait for the fans to stop rotating.

3. Check whether the fan guard is dusty or badly clogged.

If the fan guard is dusty, clean it with a vacuum cleaner or a soft brush.

If the fan guard is heavily soiled, remove it and clean it:

- Use a screwdriver to push the two locking tabs at the right-hand edge of the fan guard to the right-hand side and remove them from the retainer.

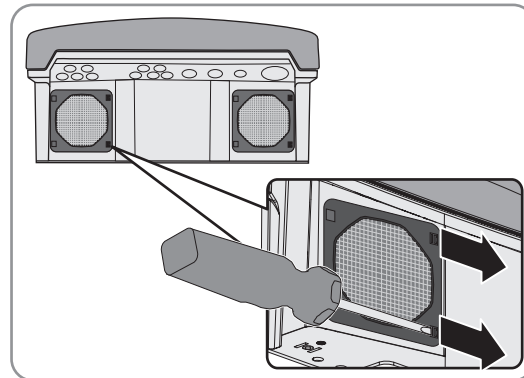

- Carefully remove the fan guard.
- Clean the fan guard with a soft brush, a paint brush, a cloth or compressed air.

4. Check whether the fan is soiled.

If the fan is soiled, remove the fan:

- Use a screwdriver to push the two locking tabs at the right-hand edge of the fan guard to the right-hand side and remove them from the retainer.

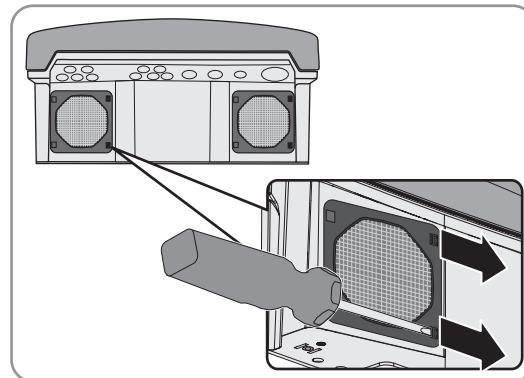

- Carefully remove the fan guard.
- Push the front locking tabs of the fan backwards and the rear locking tabs of the fan forwards.

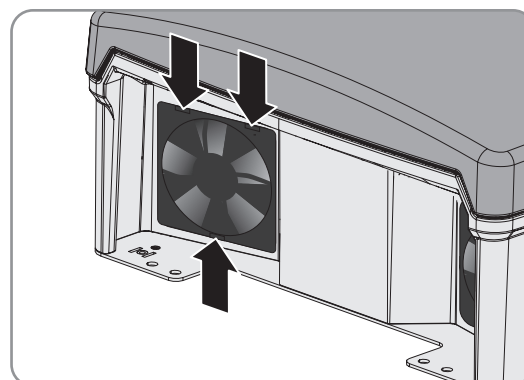

- Slowly remove the fan from the Sunny Island.

- Release and remove the fan plug.

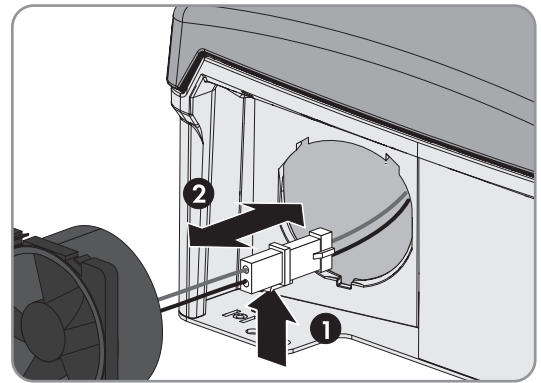

5. **NOTICE**

Damage to the fan due to compressed air

- Clean the fan with a soft brush, a paint brush, or a damp cloth.
6. Insert the plug of the fan in the pin connector until it snaps into place.
 7. Insert the fan into the Sunny Island until the fan audibly snaps into place.
 8. Press the fan guard into the bracket until it audibly snaps into place.

11.8 Replacing the Battery

⚠ WARNING

Risk of injury due to short-circuit currents

Short-circuit currents in the battery can cause heat build-up and electric arcs. Burns or eye injuries due to flashes may result.

- Remove watches, rings and other metal objects.
- Use insulated tools.
- Do not place tools or metal parts on the battery.

⚠ WARNING

Danger to life due to incompatible lithium-ion battery

An incompatible lithium-ion battery can lead to a fire or an explosion. With incompatible lithium-ion batteries, it is not ensured that battery management is intrinsically safe and will protect the battery.

- Verify that the battery complies with locally applicable standards and directives and is intrinsically safe.
- Ensure that the lithium-ion batteries are approved for use with the Sunny Island. The list of lithium-ion batteries approved for the Sunny Island is updated regularly (see the technical information "List of Approved Lithium-Ion Batteries" at www.SMA-Solar.com).
- If no lithium-ion batteries approved for the Sunny Island can be used, lead-acid batteries can be used.

⚠ WARNING**Chemical burns and poisoning due to battery electrolyte**

If handled inappropriately, battery electrolyte can cause irritation to the eyes, respiratory system and skin, and it can be toxic. This may result in blindness or serious chemical burns.

- Protect the battery enclosure against destruction.
- Do not open or deform the battery.
- Do not throw batteries into fire. Batteries may explode in fire.
- Whenever working on the battery, wear suitable personal protective equipment such as rubber gloves, an apron, rubber boots and goggles.
- Rinse acid splashes thoroughly for a long time with clear water, and consult a doctor.
- Install, operate, maintain and dispose of the battery according to the manufacturer's specifications.

NOTICE**Damage to the battery due to incorrect settings**

The set battery parameters influence the charging behavior of the Sunny Island inverter. The battery can be damaged by incorrect settings of the battery type, nominal voltage and capacity parameters.

- Ensure that the values recommended by the manufacturer are set for the battery (refer to the technical data of the battery in the manufacturer documentation). Note that the battery charging behavior names used by SMA Solar Technology AG and the battery manufacturer may, in some cases, differ in meaning (for the battery charging behavior of the Sunny Island inverter, see technical information "List of Approved Lithium-Ion Batteries").
- Set the battery capacity for a ten-hour electric discharge (C10). The battery manufacturer specifies the battery capacity in relation to discharge time.

Procedure:

1. Stop the system and switch off the Sunny Island (see Section 4, page 20).
2. Ensure that the battery is not grounded unintentionally.

If the battery is unintentionally grounded, identify the connection between the battery and ground potential and remove the unintentional connection. This helps to prevent electric shock caused by malfunction of other system devices.
3. Open the load-break switch of the BatFuse and secure against reconnection.
4. Remove the battery to be replaced (see battery manufacturer's manuals).
5. Mount and connect the new battery (see manuals of the battery manufacturer). The battery must comply with the technical requirements of the Sunny Island inverter (refer to the Sunny Island inverter installation manual for technical data of the DC connection).
6. Quickly close the load-break switch of the BatFuse and close the BatFuse (see BatFuse installation manual).
7. Switch the Sunny Island on (see Section 4.1, page 20).
8. If the Sunny Remote Control displays **<Init System>** [#], press and hold the button until the Sunny Remote Control displays the QCG.
9. Select the menu **New Battery** and press the button.
10. Confirm with **Y**.

11. Select the parameter **BatTyp**, set the battery type as follows and confirm with **Y**.

Value	Explanation
VRLA	Lead-acid battery with immobilized electrolyte in AGM (Absorbent Glass Mat Separator) or gel
FLA	Lead-acid battery with liquid electrolyte
Lilon_Ext-BMS	Lithium-ion battery

12. Make the following settings for lead-acid batteries.

- Select the parameter **BatVtgLst**, set the battery voltage and confirm with **Y**.
- Select the parameter **BatCpyNom**, set the C10 capacity of the battery (see the Sunny Island inverter installation manual for how to calculate the battery capacity) and confirm the battery capacity with **Y**.

13. Make the following settings for lithium-ion batteries.

- Select the parameter **BatCpyNom**, set the C10 capacity of the battery (see the Sunny Island inverter installation manual for how to calculate the battery capacity) and confirm the battery capacity with **Y**.

14. Select the last page and confirm the question **Setup new battery** with **Y**.

12 Decommissioning the Sunny Island

⚠ WARNING

Danger to life from electric shock due to high voltages

High voltages are present inside the Sunny Island. When the enclosure lid is removed, live components can be touched that can result in death or serious injury due to electric shock.

- Disconnect the Sunny Island from voltage sources (see Section 9, page 45).

1. Ensure that the Sunny Island is disconnected from all voltage sources (see Section 9, page 45).
2. Remove all cables from the Sunny Island.
3. Close the Sunny Island.
4. Remove the ventilation grids laterally.

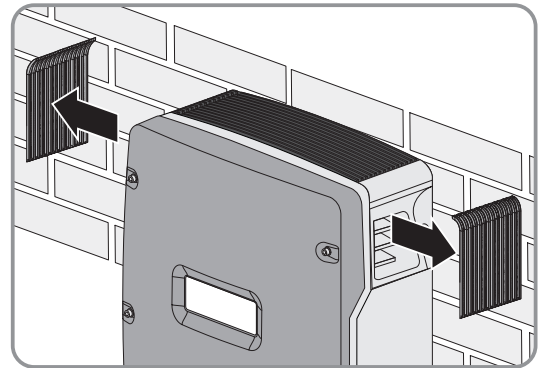

5. If the Sunny Island is protected against theft, loosen the security screws.

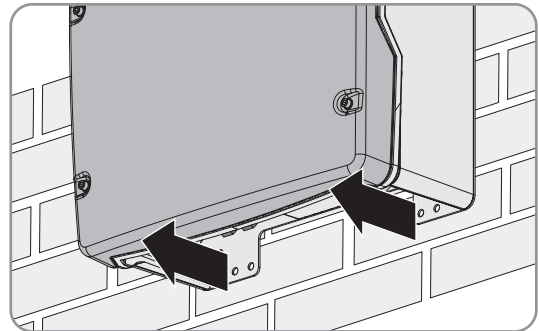

6. Loosen the screws on both sides between the Sunny Island and the wall mounting bracket using a hex key (AF 5).

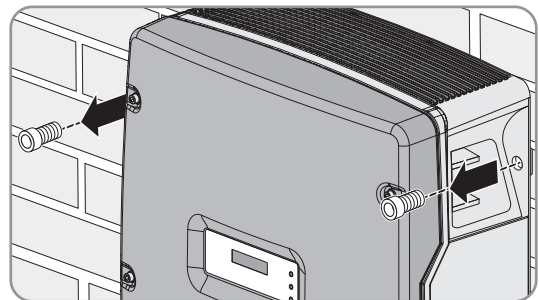

7. **CAUTION****Risk of injury due to the heavy weight of the Sunny Island inverter**

The Sunny Island weighs 44 kg resp. 63 kg. There is risk of injury if the inverter is lifted incorrectly or dropped while being transported or when attaching it to or removing it from the wall mounting bracket.

- Keep in mind the weight of the Sunny Island inverter.
- With the SI3.0M-11 and SI4.4M-11, remove the Sunny Island vertically upwards from the wall mounting bracket. For this, use the side recess grips. Keep the Sunny Island in a horizontal position when moving it.
- With the SI6.0H-11 and SI8.0H-11, remove the Sunny Island vertically upwards from the wall mounting bracket. For this, use the side recess grips or a steel rod (diameter: maximum 30 mm). Keep the Sunny Island in a horizontal position when moving it.

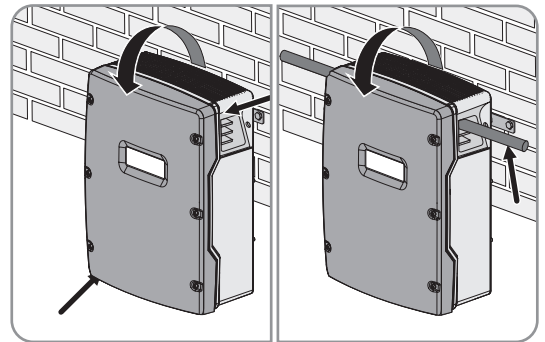
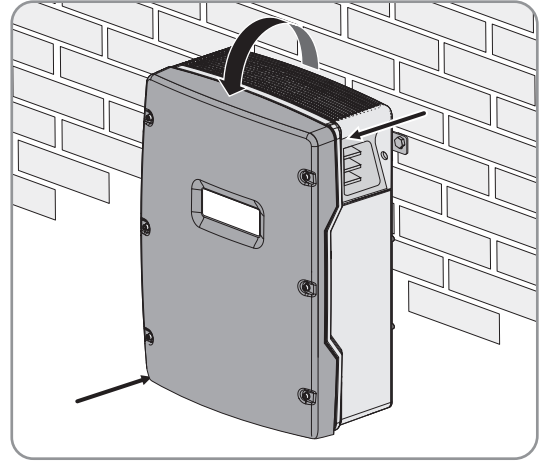



8. Remove the cable glands from the inverter.
9. If the inverter is to be stored or shipped, pack the inverter. Use the original packaging or packaging that is suitable for the weight and dimensions of the inverter.
10. Dispose of the inverter in accordance with the locally applicable disposal regulations for electronic waste.

13 Parameters in Sunny Remote Control



13.1 Directory of the Parameters in User Mode





13.1.1 Inverter Category

Display Page

Name	Description	Value	Explanation		
Tot.Power	Total active power of the Sunny Island inverters in kW This parameter is hidden in multicluster systems.	-	-	✓	✓
MC.Power	Total active power of the multicluster system in kW This parameter is hidden in single systems and single-cluster systems.	-	-	✗	✓
Timer mode	Time-controlled operation of the Sunny Island in off-grid systems	Enable	The Sunny Island is in time-controlled operation.	✗	✓
		Disable	Time-controlled operation is disabled.		



















Setting Page

Name	Description	Value	Explanation		
Restart	Restart of the Sunny Island inverter	Yes	Initiate restart.	✗	✓
		No	Do not initiate restart.		
Str.Date	Start date for time-controlled operation of the Sunny Island in dd.mm.yy In time-controlled operation, the Sunny Island switches from standby mode to operation for the first time on the start date.	-	-	✗	✓
Start time	Start time for time-controlled operation, in hh:mm:ss	-	-	✗	✓
Run Time	Run time for time-controlled operation The Sunny Island switches to operation from the start time for the configured run time.	-	-	✗	✓
Repetition	Repetition cycle for time-controlled operation	Single	Configures one-time operation on the start date.	✗	✓
		Daily	Configures daily operation from the start date.		
		Weekly	Configures weekly operation from the start date. The start date determines the weekday.		



Name	Description	Value	Explanation		
Timed start	Time-controlled operation	Disable	Disables time-controlled operation.		
		Enable	Enables time-controlled operation.		

13.1.2 Battery Category

Display Pages

Name	Description	Value	Explanation		
StateOfCharge	Current battery state of charge in %	-	-		
Voltage	Battery voltage in V	-	-		
PowerOut	Current discharge power of the battery in kW	-	If the value is positive, the battery is discharging. If the value is negative, the battery is charging.		
Mode	Current charging process	Boost	Boost charge is enabled.		
		Full	Full charge is enabled.		
		Float	Float charge is enabled.		
		Equalize	Equalization charge is enabled.		
		Silent	The Sunny Island has switched to energy-saving mode.		
Remain time	Remaining time of current charging process in h:mm:ss	-	-		
Next equal	Remaining time until next equalization charge in days	-	-		
Health (SOH)	Ratio of currently usable capacity to nominal capacity, in %	-	-		
Cycle	Nominal energy throughputs of the battery A nominal energy throughput is the calculated result of one full charge and discharge of the battery.	-	-		

Setting Pages

Name	Description	Value	Explanation		
Equalize	Manual equalization charge	Start	Starts the equalization charge.	✓	✓
		Stop	Stops the equalization charge.		
		Idle	Remains idle until the requirements for an equalization charge are met.		



13.1.3 Generator Category

Display Pages

The Sunny Remote Control displays these pages whenever a generator has been connected and configured.

Name	Description	Value	Explanation		
Power	Active power of the generator in kW	-	-	✗	✓
Voltage	Generator voltage	-	-	✗	✓
Frequency	Frequency of generator voltage	-	-	✗	✓
Request by	Source for generator request	None	Generator has not been requested.	✗	✓
		Bat	Electricity generator was requested due to state of charge.		
		Lod	Electricity generator was requested due to load.		
		Tim	Generator requested due to time.		
		Run 1 h	Generator manually requested for one hour.		
		Start	Generator was started manually.		
		ExtSrcReq	Generator was requested externally.		
Run Time	Current run time of the generator in hh:mm:ss	-	-	✗	✓
Energy	Energy supplied by the generator since the last start in kWh	-	-	✗	✓
No.OfStarts	Number of generator starts	-	-	✗	✓
Op.Hours	Total operating hours of the generator	-	-	✗	✓
Tot.Energy	Total energy supplied by the generator in kWh	-	-	✗	✓



Setting Pages

Name	Description	Value	Explanation		
Mode	Generator control	Auto	Enable automatic generator operation.	✓	✓
		Stop	Stops the generator.		
		Start	Start the generator.		
		Run 1 h	Starts the generator for one hour.		
Error	Error confirmation for generator error	Ackn	Acknowledge the error.	✗	✓



13.1.4 Grid Category

Display Pages

The Sunny Remote Control displays these pages in a battery backup system.

Name	Description		
Power	Active power of utility grid in kW	✓	✗
Voltage	Voltage of utility grid in V	✓	✗
Frequency	Frequency of the utility grid, in Hz	✓	✗



Setting Pages

Name	Description	Value	Explanation		
Mode	Manual connection to the utility grid	Auto	Enables automatic connection to the utility grid.	✓	✗
		Stop	Disconnects the Sunny Island from the utility grid.		
		Start	Connects the Sunny Island to the utility grid.		

13.1.5 SI Charger Category

Display Pages



The Sunny Remote Control only shows this page if at least one Sunny Island Charger is used in the off-grid system.

Name	Description		
Tot.Power	Total PV power of all Sunny Island Charger charge controllers in kW	✗	✓
Tot.Energy	Energy of all Sunny Island Charger charge controllers in kWh	✗	✓
Day Energy	Total PV energy today This is the total energy of all Sunny Island Charger charge controllers in kWh	✗	✓

13.1.6 Self Cnsmptn Category

Display Pages



The Sunny Remote Control displays these pages if the PV generation in a system for increased self-consumption is transferred to the Sunny Island.

Name	Description		
IncPower	Current increased self-consumption in kW	✓	✗
IncToday	Today's increased self-consumption in kWh	✓	✗
IncEnergy	Total increased self-consumption in kWh	✓	✗
Energy	Energy consumed internally in kWh	✓	✗

13.1.7 Grid Cnsmptn Category

Display Pages

The Sunny Remote Control displays these pages in a system for increased self-consumption.

Name	Description		
Power	Power drawn from the utility grid in kW	✓	✗
Energy	Energy drawn from the utility grid in kWh	✓	✗

13.1.8 Grid Feed Category

Display Pages



The Sunny Remote Control displays these pages in a system for increased self-consumption.

Name	Description		
Power	Power fed into the utility grid in kW	✓	✗
Energy	Today's grid feed-in in kWh	✓	✗

13.1.9 Loads Category

Display Pages



The Sunny Remote Control displays these pages if PV generation in a system for increased self-consumption is transferred to the Sunny Island.

Name	Description		
Power	Current power of the loads in kW	✓	✗
Energy	Consumption meter reading in kWh	✓	✗
ConState	Reserved for future applications	✓	✗

13.1.10 PV System Category



Display Pages

The Sunny Remote Control displays these pages if PV generation in a system for increased self-consumption is transferred to the Sunny Island.

Name	Description		
Power	Power PV generation in kW	✓	✗
Energy	PV production meter reading in kWh	✓	✗
ConState	Reserved for future applications	✓	✗

13.1.11 System Category



Display Pages

Name	Description	Value	Explanation		
Type	Configuration of the system	1Phase1	Single-phase system with one Sunny Island	✓	✓
		1Phase2	Single-phase system with two Sunny Island inverters	✗	✓
		1Phase3	Single-phase system with three Sunny Island inverters	✗	✓
		3Phase	Three-phase system	✓	✓
Box Type	Type of connected Multicluster-Box This parameter is shown only in multicluster systems.	MC-Box-6	Multicluster-Box 6	✗	✓
		MC-Box-12	Multicluster-Box 12 (MC-BOX-12.3)	✗	✓
		MC-Box-12-2x*	Multicluster-Box 12 (MC-BOX-12.3-20)	✓	✓
		MC-Box-36	Multicluster-Box 36	✗	✓
Device	Type of cluster This parameter is shown only in multicluster systems.	MainClst	Sunny Remote Control is connected to the main cluster.	✗	✓
		ExtnClst	The Sunny Remote Control is connected to the extension cluster.		



* Value is visible until firmware version 3.5 of the Sunny Island

13.1.12 Time Category



Display Pages

Name	Description		
Date	Date in dd.mm.yyyy	✓	✓
Time	Time in hh:mm:ss	✓	✓



Setting Page

Name	Description	Explanation		
Date	Date in dd.mm.yyyy	Set the date.	✓	✓
Time	Time in hh:mm:ss	Set the time.	✓	✓



13.1.13 Identity Category**Display Pages**

Name	Description		
Serial No.	Serial number	✓	✓
Firmware	Firmware version	✓	✓



13.1.14 Password Category**Display Pages**

Name	Description	Value	Explanation		
Level	Current password level	User	Sunny Remote Control is in user mode.	✓	✓

Setting Page

Name	Description		
Set	Enter the installer password.	✓	✓
Runtime	Displays the operating hours	✓	✓



13.2 Directory of the Parameters in Installer Mode and Expert Mode**13.2.1 Display Values****13.2.1.1 Inverter (110#)****111# Total**

No.	Name	Description		
111.01	TotInvPwrAt	Total active power of Sunny Island inverters in a cluster in kW	✓	✓
111.02	TotInvCur	Total current of Sunny Island inverters in a cluster in A	✓	✓
111.03	TotInvPwrRt	Total reactive power of Sunny Island inverters in a cluster in kVAr (expert mode)	✓	✓
111.05	TotLodPwr	Total current active power of the loads in a cluster in kW	✓	✓
111.07	TotMcclnVpwr	Total active power currently supplied in the multicluster system in kW	✓	✓



112# Device

No.	Name	Description	Value (Plain text no.)	Explanation		
112.01	InvOpStt	Operating state of the Sunny Island inverter	Init (1)	Initialization	✓	✓
			Startup (2)	Switch from standby to operation		
			Standby (3)	Standby		
			Run (4)	Operation		
			I-Loop (5)	Current-controlled generator operation		
			Error (6)	Error status		
112.02	InvPwrAt	Active power of the Sunny Island inverter at line conductor L1 in kW	-	-	✓	✓
112.03	InvVtg	Grid voltage of the Sunny Island inverter at line conductor L1 in V	-	-	✓	✓
112.04	InvCur	Line current of the Sunny Island inverter at line conductor L1 in A	-	-	✓	✓
112.05	InvFrq	Grid frequency of the Sunny Island inverter in Hz	-	-	✓	✓
112.06	InvPwrRt	Reactive power of the Sunny Island inverter at line conductor L1 in kVAr (expert mode)	-	-	✓	✓
112.07	Rly1Stt	Multifunction relay status 1	Off	Multifunction relay is deactivated.	✓	✓
			On	Multifunction relay is activated.		
112.08	Rly2Stt	Multifunction relay status 2	Off	Multifunction relay is deactivated.	✓	✓
			On	Multifunction relay is activated.		
112.12	TrfTmp	Temperature of the transformer in °C (expert mode) The temperature of the transformer is displayed in the master of a cluster.	-	-	✓	✓
112.13	HsTmp	Temperature of the heat sink in the Sunny Island in °C (expert mode) The temperature of the heat sink is displayed in the master of a cluster.	-	-	✓	✓



113# Slave1

No.	Name	Description	Value (Plain text no.)	Explanation		
113.01	InvOpSttSlv1	Operating state of slave 1	Init (1)	Initialization	✓	✓
			Startup (2)	Switch from standby to operation		
			Standby (3)	Standby		
			Run (4)	Operation		
			I-Loop (5)	Current-controlled generator operation		
			Error (6)	Error status		
113.02	InvPwrAtSlv1	Active power of slave 1 at line conductor L2 in kW	-	-	✓	✓
113.03	InvVtgSlv1	Line voltage of slave 1 at line conductor L2 in V	-	-	✓	✓
113.04	InvCurSlv1	Line current of the slave 1 at line conductor L2 in A	-	-	✓	✓
113.05	InvPwrRtSlv1	Reactive power of slave 1 at line conductor L2 in kVAr (expert mode)	-	-	✓	✓
113.06	Rly1SttSlv1	Multifunction relay status 1 of slave 1	Off	Multifunction relay is deactivated.	✓	✓
			On	Multifunction relay is activated.		
113.07	Rly2SttSlv1	Multifunction relay status 2 of slave 1	Off	Multifunction relay is deactivated.	✓	✓
			On	Multifunction relay is activated.		
113.09	TrfTmpSlv1	Temperature of the transformer in slave 1 in °C (expert mode)	-	-	✓	✓
113.10	HsTmpSlv1	Temperature of the heat sink in slave 1 in °C (expert mode)	-	-	✓	✓

114# Slave2



No.	Name	Description	Value (Plain text no.)	Explanation		
114.01	InvOpSttSlv2	Operating state of slave 2	Init (1)	Initialization	✓	✓
			Startup (2)	Switch from standby to operation		
			Standby (3)	Standby		
			Run (4)	Operation		
			I-Loop (5)	Current-controlled generator operation		
			Error (6)	Error status		
114.02	InvPwrAtSlv2	Active power of slave 2 at line conductor L3 in kW	-	-	✓	✓
114.03	InvVtgSlv2	Line voltage of slave 2 at line conductor L3 in V	-	-	✓	✓
114.04	InvCurSlv2	Line current of slave 2 at line conductor L3 in A	-	-	✓	✓
114.05	InvPwrRtSlv2	Reactive power of slave 2 at line conductor L3 in kVAr (expert mode)	-	-	✓	✓
114.06	Rly1SttSlv2	Multifunction relay status 1 of slave 2	Off	Multifunction relay is deactivated.	✓	✓
			On	Multifunction relay is activated.		
114.07	Rly2SttSlv2	Multifunction relay status 2 of slave 2	Off	Multifunction relay is deactivated.	✓	✓
			On	Multifunction relay is activated.		
114.09	TrfTmpSlv2	Temperature of the transformer in slave 2 in °C (expert mode)	-	-	✓	✓
114.10	HsTmpSlv2	Temperature of the heat sink in slave 2 in °C (expert mode)	-	-	✓	✓

13.2.1.2 Battery (120#)

No.	Name	Description	Value (Plain text no.)	Explanation		
120.01	BatSoc	State of charge of the battery (SOC) based on the nominal battery capacity in %	0% to 100%	-	✓	✓
120.02	BatVtg	Battery voltage in V	-	-	✓	✓
120.03	BatChrgVtg	Current battery charging voltage set-point in V	-	-	✓	✓
120.04	AptTmRmg	Remaining absorption time for completion of the current battery charge phase 120.05 BatChrgOp in hh:m-m:ss	-	-	✓	✓
120.05	BatChrgOp	Active battery charging mode	Boost (1)	Boost charge	✓	✓
			Full (2)	Full charge		
			Float (3;7)	Float charge		
			Equalize (4;5)	Equalization charge		
			Silent (6;8)	Energy-saving mode active		
120.06	TotBatCur	Total battery current of the cluster in A	-	-	✓	✓
120.07	BatTmp	Battery temperature in °C	-	-	✓	✓
120.08	RmgTmFul	Remaining time until next full charge in days	-	-	✓	✓
120.09	RmgTmEqu	Remaining time until next equalization charge in days	-	-	✓	✓
120.10	AptPhs	Status of the absorption phase	Off (1)	Absorption phase not active	✓	✓
			On (2)	Absorption phase is active		
120.11	BatSocErr	Estimated error of the battery state of charge (SOC) in % (expert mode)	-	-	✓	✓
120.12	BatCpyThrp Cnt	Number of nominal energy throughputs of the battery A nominal energy throughput is the calculated result of one full charge and discharge of the battery.	-	-	✓	✓

13.2.1.3 External (130#)











131# Total

No.	Name	Description		
131.01	TotExtPwrAt	Total active power of the external grid connection in kW	✓	✓
131.02	TotExtCur	Total current of the external grid connection in A	✓	✓
131.03	TotExtPwrRt	Total reactive power of the external grid connection in kvar	✓	✓







132# Grid State



No.	Name	Description	Value (Plain text no.)	Explanation		
132.01	GdStt	Utility grid status (expert mode)	Off (1)	Off; Grid operation is disabled.	✓	✓
			Init (2)	Initialization; Utility grid has been detected.		
			Detect (3)	Grid monitoring started.		
			Wait (4)	Waiting until the stand-alone grid is synchronized with the utility grid.		
			RunVExt (5)	Grid operation without feedback; The stand-alone grid is synchronized with and connected to the utility grid.		
			Feed (6)	Grid operation with feedback; Grid feed-in into the utility grid is possible.		
			Silent (7)	Energy-saving in the utility grid; the Sunny Island is in energy-saving mode.		
			SiStr (8)	The Sunny Island is switching to energy-saving mode.		
			SiStp (9)	The Sunny Island is leaving energy-saving mode.		
			Error (10)	An error occurred when connecting.		
			Reinit (11)	Initialization; Utility grid has been detected again.		
132.02	GdRmgTm	Standby time to feed-in in hh:m- m:ss This is the remaining time of grid monitoring in hh:mm:ss	-	-	✓	✓

133# Gen State



No.	Name	Description	Value (Plain text no.)	Explanation	 
133.01	GnDmdSrc	Reason for requesting generator:	None (1)	No request	 
			Bat (2)	State-of-charge-dependent request	
			Lod (3)	Load-dependent request	
			Tim (4)	Time-controlled request	
			Run 1 h (5)	Requested for 1 hour	
			Start (6)	Manually started	
			ExtSrcReq (7)	External generator request	
133.02	GnStt	Generator state	Off (1)	Deactivated generator operation	 
			Init (2)	Detecting generator	
			Ready (3)	Waiting for request (ready)	
			Warm (4)	Warming up	
			Connect (5)	Connecting	
			Run (6)	Operation	
			Retry (7)	Restarting	
			Disconnect (8)	Split	
			Cool (9)	Cooling down	
			Lock (10)	Locked after operation	
			Fail (11)	Error	
			FailLock (12)	Locked after error	
			Reinit (13)	Re-detection of the generator	
133.03	GnRmgTm	Remaining minimum run time of the generator in hh:mm:ss	-	-	 
133.04	GnRnStt	Status of the digital input for generator feedback (expert mode)	Off (1)	Off	 
			On (2)	On	

134# Device



No.	Name	Description	 
134.01	ExtPwrAt	Total active power of the external grid connection at line conductor L1 in kW	 
134.02	ExtVtg	Voltage of the external grid connection at line conductor L1 in V	 

No.	Name	Description		
134.03	ExtCur	Current of the external grid connection at line conductor L1 in A	✘	✓
134.04	ExtFrq	Frequency of external energy source in Hz	✘	✓
134.05	ExtPwrRt	Reactive power of the external grid connection at line conductor L1 in kVAr (expert mode)	✘	✓
134.07	ExtLkRmgTm	Minimum stop time in hh:mm:ss	✘	✓



135# Slave1

No.	Name	Description		
135.01	ExtPwrAtSlv1	Total active power of the external grid connection at slave 1 / line conductor L2 in kW	✘	✓
135.02	ExtVtgSlv1	Voltage of the external grid connection at slave 1 / line conductor L2 in V	✘	✓
135.03	ExtCurSlv1	Current of the external grid connection at slave 1 / line conductor L2 in A	✘	✓
135.04	ExtPwrRtSlv1	Reactive power of the external grid connection at slave 1 line conductor L2 in kVAr (expert mode)	✘	✓



136# Slave2

No.	Name	Description		
136.01	ExtPwrAtSlv2	Total active power of the external grid connection at slave 2 / line conductor L3 in kW	✘	✓
136.02	ExtVtgSlv2	Voltage of the external grid connection at slave 2 / line conductor L3 in V	✘	✓
136.03	ExtCurSlv2	Current of the external grid connection at slave 2 / line conductor L3 in A	✘	✓
136.04	ExtPwrRtSlv2	Reactive power of the external grid connection at slave 2 line conductor L3 in kVAr (expert mode)	✘	✓



13.2.1.4 Charge Controller (140#)**141# SIC50 Total**

No.	Name	Description		
141.01	TotSicEgyCntln	Total PV energy: This is the total energy of all Sunny Island Charger charge controllers in kWh	✘	✓
141.02	TSicDyEgyCntln	Total PV energy today: This is the total energy of all Sunny Island Charger charge controllers in kWh	✘	✓
141.03	TotSicPvPwr	Total PV power of all Sunny Island Charger charge controllers in W	✘	✓
141.04	TotSicBatCur	Total output current of all Sunny Island Charger charge controllers in A	✘	✓



142# SIC50 1

No.	Name	Description		
142.01	Sic1EgyCntln	Total PV energy of Sunny Island Charger charge controller 1 in kWh	✘	✓
142.02	Sic1TdyEgyCntln	Daily energy of Sunny Island Charger charge controller 1 in kWh	✘	✓
142.03	Sic1PvPwr	PV power of Sunny Island Charger charge controller 1 in W	✘	✓
142.04	Sic1PvVtg	PV voltage of Sunny Island Charger charge controller 1 in V	✘	✓
142.05	Sic1BatVtg	Battery voltage of Sunny Island Charger charge controller 1 in V (expert mode)	✘	✓
142.06	Sic1BatCur	Battery current of Sunny Island Charger charge controller 1 in A (expert mode)	✘	✓
142.07	Sic1HsTmp	Heat sink temperature of Sunny Island Charger charge controller 1 in °C (expert mode)	✘	✓

143# SIC50 2

No.	Name	Description		
143.01	Sic2EgyCntln	Total PV energy of Sunny Island Charger charge controller 2 in kWh	✘	✓
143.02	Sic2TdyEgyCntln	Daily energy of Sunny Island Charger charge controller 2 in kWh	✘	✓
143.03	Sic2PvPwr	PV power of Sunny Island Charger charge controller 2 in W	✘	✓
143.04	Sic2PvVtg	PV voltage of Sunny Island Charger charge controller 2 in V	✘	✓
143.05	Sic2BatVtg	Battery voltage of Sunny Island Charger charge controller 2 in V (expert mode)	✘	✓
143.06	Sic2BatCur	Battery current of Sunny Island Charger charge controller 2 in A (expert mode)	✘	✓
143.07	Sic2HsTmp	Heat sink temperature of Sunny Island Charger charge controller 2 in °C (expert mode)	✘	✓

144# SIC50 3

No.	Name	Description		
144.01	Sic3EgyCntln	Total PV energy of Sunny Island Charger charge controller 3 in kWh	✘	✓
144.02	Sic3TdyEgyCntln	Daily energy of Sunny Island Charger charge controller 3 in kWh	✘	✓
144.03	Sic3PvPwr	PV power of Sunny Island Charger charge controller 3 in W	✘	✓
144.04	Sic3PvVtg	PV voltage of Sunny Island Charger charge controller 3 in V	✘	✓
144.05	Sic3BatVtg	Battery voltage of Sunny Island Charger charge controller 3 in V (expert mode)	✘	✓

No.	Name	Description		
144.06	Sic3BatCur	Battery current of Sunny Island Charger charge controller 3 in A (expert mode)	✘	✓
144.07	Sic3HsTmp	Heat sink temperature of Sunny Island Charger charge controller 3 in °C (expert mode)	✘	✓

145# SIC50 4

No.	Name	Description		
145.01	Sic4EgyCntIn	Total PV energy of Sunny Island Charger charge controller 4 in kWh	✘	✓
145.02	Sic4TdyEgyCntIn	Daily energy of Sunny Island Charger charge controller 4 in kWh	✘	✓
145.03	Sic4PvPwr	PV power of Sunny Island Charger charge controller 4 in W	✘	✓
145.04	Sic4PvVtg	PV voltage of Sunny Island Charger charge controller 4 in V	✘	✓
145.05	Sic4BatVtg	Battery voltage of Sunny Island Charger charge controller 4 in V (expert mode)	✘	✓
145.06	Sic4BatCur	Battery current of Sunny Island Charger charge controller 4 in A (expert mode)	✘	✓
145.07	Sic4HsTmp	Heat sink temperature of Sunny Island Charger charge controller 4 in °C (expert mode)	✘	✓

13.2.1.5 Compact (150#)

The menu **150# Compact** displays multiple parameters from the following areas at a glance:



- Battery
- AC measured values of the Sunny Island inverter
- Electric generator or utility grid
- Status of the Sunny Island Inverter

Battery (Bat)



Figure 15: Overview of the menu **Meters Compact** for the battery



Position	Description	Parameter		
A	Battery state of charge (SOC) as %	120.01 BatSoc	✓	✓
B	Estimated error of the battery state of charge (SOC) in % (expert mode)	120.11 BatSocErr	✓	✓
C	Battery temperature in °C	120.07 BatTmp	✓	✓

Position	Description	Parameter		
D	Charging voltage setpoint in V	120.03 BatChrgVtg	✓	✓
E	Battery voltage in V	120.02 BatVtg	✓	✓
F	Total battery current of the cluster in A	120.06 TotBatCur	✓	✓

AC Measured Values of the Sunny Island Inverter (Inv)





Figure 16: Overview of the menu **Meters Compact** for the AC measured values of the Sunny Island inverter

Position	Description	Parameter		
A	Voltage of the Sunny Island inverter in V	112.03 InvVtg	✓	✓
B	Voltage frequency of the Sunny Island inverter in Hz	112.05 InvFrq	✓	✓
C	Reactive power of the inverter in kVAr	112.06 InvPwrRt	✓	✓
D	Active power of the inverter in kW	112.02 InvPwrAt	✓	✓

Generator or Utility Grid (Ext)



Figure 17: Overview of the menu **Meters Compact** for the generator or the battery backup grid

Position	Description	Parameter		
A	Voltage of generator or utility grid in V	134.02 ExtVtg	✓	✓
B	Frequency of generator or utility grid in Hz	134.04 ExtFrq	✓	✓
C	Reactive power of generator or utility grid in kVAr	134.05 ExtPwrRt	✓	✓
D	Active power of generator or utility grid in kW	134.01 ExtPwrAt	✓	✓

Status of the Sunny Island Inverter (OpStt)



Figure 18: Overview of the menu **Meters Compact** for the status of the Sunny Island inverter

Position	Description	Value	Explanation	Parameter		
A	Operating state of the Sunny Island inverter	Init	Initialization	112.01 InvOpStt	✓	✓
		Standby	Standby			
		Run	Operation			
		EmChargeMod	Emergency charge mode			
		Error	Error			

13.2.1.6 SlfCsmP (160#)

161# Power

No.	Name	Description		
161.01	TotPvPwrAt	Power PV generation in kW	✓	✗
161.02	TotLodPwrAt	Total power of the loads in kW	✓	✗
161.03	SlfCsmPwrAt	Current self-consumption in kW	✓	✗
161.04	SlfCsmPlncPwr	Current increased self-consumption in kW	✓	✗
161.05	GdCsmPwrAt	Power drawn from the utility grid in kW	✓	✗
161.06	GdFeedPwrAt	Power fed into the utility grid in kW	✓	✗

162# Energy

No.	Name	Description		
162.01	TotLodEgyCnt	Consumption meter reading in kWh	✓	✗
162.02	SlfCsmPlncEgy	Total increased self-consumption in kWh	✓	✗
162.03	SlfCsmPlncTdy	Today's increased self-consumption in kWh	✓	✗
162.04	SlfCsmPEgy	Energy consumed internally in kWh	✓	✗
162.05	GdCsmPEgyMtr	Purchased electricity meter reading in kWh	✓	✗
162.06	GdCsmPEgyTdy	Today's purchased electricity in kWh	✓	✗
162.07	GdFeedEgyMtr	Feed-in meter reading in kWh	✓	✗

No.	Name	Description		
162.08	PvEgyMtr	PV production meter reading in kWh	✓	✗
162.09	GdFeedEgyTdy	Today's grid feed-in in kWh	✓	✗



163# State

No.	Name	Description	Value	Explanation		
163.01	BatMntStt	Battery maintenance charge status: If full charge or equalization charge with PV energy has not ended after 24 hours, 163.01 BatMntStt automatically switches to On .	On	Charge with solar power: Full charge or equalization charge active; energy is drawn from the utility grid	✓	✗
			Wait	Charge with solar power: If sufficient PV energy is available, full charge or equalization charge active		
			Off	Inactive: No full charge or equalization charge active		
163.02	SlfCsmptSOCArea	Status of the battery utilization range In systems for increased self-consumption and in battery-backup systems, this parameter shows in which range the state of charge of the battery is currently in (expert mode).	SlfCsmptSOC	Range for increased self-consumption	✓	✗
			PVResSOC	Range for maintenance of the battery state of charge		
			BUResSOC	Range for the battery backup system function		
			BatResSOC	Range for protection against deep discharge		
			ProtResSOC	Range for protection in the event of deep discharge		
163.03	SlfCsmptSOCLim	Lower discharge limit for self-consumption range as %: With this updated display value, the Sunny Island inverter informs of the state of charge up to which the battery for increased self-consumption is discharged (expert mode).	5% to 90%	-	✓	✗

13.2.1.7 Multicluster (170#)

171# Total



The menu **171# Total** is visible until firmware version 3.5 of the Sunny Island. Firmware version 3.5 of Sunny Island can only be used in multicluster systems with the Multicluster-Box 12 of device type MC-BOX-12.3-20.



No.	Name	Description		
171.01	MCBatSOC	Battery state of charge of the multicluster systems as %	✓	✓

172# Ext.Cluster

The menu **172# Ext.Cluster** is visible until firmware version 3.5 of the Sunny Island. Firmware version 3.5 of Sunny Island can only be used in multicluster systems with the Multicluster-Box 12 of device type MC-BOX-12.3-20.



No.	Name	Description	Value	Explanation		
172.01	BatSOCExt1	Battery state of charge of extension cluster 1 as %	-	-	✓	✓
172.02	BatSOCExt2	Battery state of charge of extension cluster 2 as %	-	-	✓	✓
172.03	BatSOCExt3	Battery state of charge of extension cluster 3 as %	-	-	✓	✓
172.04	BatSOCExt4	Battery state of charge of extension cluster 4 as %	-	-	✗	✓
172.05	BatSOCExt5	Battery state of charge of extension cluster 5 as %	-	-	✗	✓
172.06	BatSOCExt6	Battery state of charge of extension cluster 6 as %	-	-	✗	✓
172.07	BatSOCExt7	Battery state of charge of extension cluster 7 as %	-	-	✗	✓
172.08	BatSOCExt8	Battery state of charge of extension cluster 8 as %	-	-	✗	✓
172.09	BatSOCExt9	Battery state of charge of extension cluster 9 as %	-	-	✗	✓
172.10	BatSOCExt10	Battery state of charge of extension cluster 10 as %	-	-	✗	✓
172.11	BatSOCExt11	Battery state of charge of extension cluster 11 as %	-	-	✗	✓
172.13	TotInvPwrAtExt1	Active power of extension cluster 1 in kW	-	-	✓	✓
172.14	TotInvPwrAtExt2	Active power of extension cluster 2 in kW	-	-	✓	✓
172.15	TotInvPwrAtExt3	Active power of extension cluster 3 in kW	-	-	✓	✓



No.	Name	Description	Value	Explanation		
172.16	TotInvPwrAtExt4	Active power of extension cluster 4 in kW	-	-	✘	✓
172.17	TotInvPwrAtExt5	Active power of extension cluster 5 in kW	-	-	✘	✓
172.18	TotInvPwrAtExt6	Active power of extension cluster 6 in kW	-	-	✘	✓
172.19	TotInvPwrAtExt7	Active power of extension cluster 7 in kW	-	-	✘	✓
172.20	TotInvPwrAtExt8	Active power of extension cluster 8 in kW	-	-	✘	✓
172.21	TotInvPwrAtExt9	Active power of extension cluster 9 in kW	-	-	✘	✓
172.22	TotInvPwrAtExt10	Active power of extension cluster 10 in kW	-	-	✘	✓
172.23	TotInvPwrAtExt11	Active power of extension cluster 11 in kW	-	-	✘	✓
172.25	TotInvPwrRtExt1	Reactive power of extension cluster 1 in kVAr	-	-	✓	✓
172.26	TotInvPwrRtExt2	Reactive power of extension cluster 2 in kVAr	-	-	✓	✓
172.27	TotInvPwrRtExt3	Reactive power of extension cluster 3 in kVAr	-	-	✓	✓
172.28	TotInvPwrRtExt4	Reactive power of extension cluster 4 in kVAr	-	-	✘	✓
172.29	TotInvPwrRtExt5	Reactive power of extension cluster 5 in kVAr	-	-	✘	✓
172.30	TotInvPwrRtExt6	Reactive power of extension cluster 6 in kVAr	-	-	✘	✓
172.31	TotInvPwrRtExt7	Reactive power of extension cluster 7 in kVAr	-	-	✘	✓
172.32	TotInvPwrRtExt8	Reactive power of extension cluster 8 in kVAr	-	-	✘	✓
172.33	TotInvPwrRtExt9	Reactive power of extension cluster 9 in kVAr	-	-	✘	✓
172.34	TotInvPwrRtExt10	Reactive power of extension cluster 10 in kVAr	-	-	✘	✓
172.35	TotInvPwrRtExt11	Reactive power of extension cluster 11 in kVAr	-	-	✘	✓

No.	Name	Description	Value	Explanation		
172.37	OpSttExt1	Operating state of extension cluster 1	Operating (1)	Operation	✓	✓
			Warning (2)	Warning		
			Failure (3)	Error		
172.38	OpSttExt2	Operating state of extension cluster 2	see 172.32 OpSttExt1		✓	✓
172.39	OpSttExt3	Operating state of extension cluster 3	see 172.32 OpSttExt1		✓	✓
172.40	OpSttExt4	Operating state of extension cluster 4	see 172.32 OpSttExt1		✗	✓
172.41	OpSttExt5	Operating state of extension cluster 5	see 172.32 OpSttExt1		✗	✓
172.42	OpSttExt6	Operating state of extension cluster 6	see 172.32 OpSttExt1		✗	✓
172.43	OpSttExt7	Operating state of extension cluster 7	see 172.32 OpSttExt1		✗	✓
172.44	OpSttExt8	Operating state of extension cluster 8	see 172.32 OpSttExt1		✗	✓
172.45	OpSttExt9	Operating state of extension cluster 9	see 172.32 OpSttExt1		✗	✓
172.46	OpSttExt10	Operating state of extension cluster 10	see 172.32 OpSttExt1		✗	✓
172.47	OpSttExt11	Operating state of extension cluster 11	see 172.32 OpSttExt1		✗	✓

13.2.2 Adjustable Parameters

13.2.2.1 Inverter (210#)

No.	Name	Description	Value	Explanation			Default Value
210.01	InvVtgNom	Nominal voltage of the Sunny Island inverter in V	202.0 V to 253.0 V	230 V / 50 Hz	✓	✓	230.0 V
			202.0 V to 242.0 V	220 V / 60 Hz			220.0 V
210.02	InvFrqNom	Nominal frequency of the Sunny Island inverter in Hz (expert mode)	45.0 Hz to 55.0 Hz	230 V / 50 Hz	✓	✓	50.0 Hz
			55.0 Hz to 65.0 Hz	220 V / 60 Hz			60.0 Hz

No.	Name	Description	Value	Explanation			Default Value
210.03	In- vChrgCurMax	Maximum AC current during charging and discharging in A (expert mode) The actual AC current can be limited due to normative requirements.	0 A to 26.1 A	SI 8.0H	✓	✓	26.1 A
			0 A to 20.0 A	SI 6.0H			20.0 A
			0 A to 14.3 A	SI 4.4M			14.3 A
			0 A to 10 A	SI 3.0M			10 A

13.2.2.2 Battery (220#)



NOTICE

Damage to the battery due to incorrect settings

The set battery parameters influence the charging behavior of the Sunny Island inverter. The battery can be damaged by incorrect settings of the battery type, nominal voltage and capacity parameters.

- Ensure that the values recommended by the manufacturer are set for the battery (refer to the technical data of the battery in the manufacturer documentation). Note that the battery charging behavior names used by SMA Solar Technology AG and the battery manufacturer may, in some cases, differ in meaning (for the battery charging behavior of the Sunny Island inverter, see technical information "List of Approved Lithium-Ion Batteries").
- Set the battery capacity for a ten-hour electric discharge (C10). The battery manufacturer specifies the battery capacity in relation to discharge time.

221# Property

No.	Name	Description	Value	Explanation			Default Value
221.01	BatTyp	Battery type	VRLA	Valve-regulated lead-acid battery with immobilized electrolyte in gel or glass mat	✓	✓	-
			FLA	Valve-regulated lead-acid battery with liquid electrolyte			
			Lilon	Lithium-ion battery			
221.02	BatCpyNom	Battery nominal capacity C10 in Ah	100 Ah to 10000 Ah	VRLA, FLA	✓	✓	166 Ah
			50 to 10000 Ah	Lithium-ion			
221.03	BatVtgNom	Battery nominal voltage in V	40.0 V to 48.0 V	-	✓	✓	-
221.04	BatTmpMax	Maximum battery temperature in °C (expert mode)	221.05 BatTmpStr to 50°C	-	✓	✓	40°C

No.	Name	Description	Value	Explanation			Default Value
221.05	BatTmpStr	Battery temperature as connection limit after overtemperature disconnection in °C (expert mode)	0°C to 221.04 BatTmpMax	-	✓	✓	35°C
221.06	BatWirRes	Cable resistance of the battery connection, in mΩ (expert mode)	0 mΩ to 100 mΩ	-	✓	✓	0 mΩ
221.07	BatFanTmpStr	Temperature limit for multi-function relay with battery room fan (BatFan function) in °C	20°C to 221.04 BatTmpMax	-	✓	✓	40°C







222# Chargemode

No.	Name	Description	Value	Explanation			Default Value
222.01	BatChrgCurMax	Maximum battery charging current in A	10 A to 900 A	-	✓	✓	-
222.02	AptTmBoost	Absorption time of the boost charge in minutes (expert mode)	1 min to 600 min	For VRLA For FLA	✓	✓	180 min 90 min
222.03	AptTmFul	Absorption time for full charge in hours (expert mode)	1.0 h to 20.0 h	-	✓	✓	6.0 h
222.04	AptTmEqu	Absorption time for equalization charge in hours (expert mode)	1.0 h to 48.0 h	-	✓	✓	12.0 h
222.05	CycTmFul	Cycle time of full charge in days (expert mode)	1 d to 180 d	-	✓	✓	14 d
222.06	CycTmEqu	Cycle time of equalization charge in days (expert mode)	7 d to 365 d	-	✓	✓	90 d
222.07	ChrgVtgBoost	Setpoint of the cell voltage at boost charge in V (expert mode)	2.20 V to 2.70 V	VRLA FLA, off-grid FLA, on-grid	✓ ✗ ✓	✓ ✓ ✗	2.40 V 2.40 V 2.55 V
222.08	ChrgVtgFul	Cell voltage setpoint for full charge in V (expert mode)	2.30 V to 2.70 V	Off-grid On Grid	✗ ✓	✓ ✗	2.45 V 2.50 V









No.	Name	Description	Value	Explanation			Default Value
222.09	ChrgVtgEqu	Cell voltage setpoint for equalization charge in V (expert mode)	2.30 V to 2.70 V	Off-grid	<input checked="" type="checkbox"/>	<input checked="" type="checkbox"/>	2.45 V
				VRLA, on-grid	<input checked="" type="checkbox"/>	<input checked="" type="checkbox"/>	2.55 V
				FLA, on-grid	<input checked="" type="checkbox"/>	<input checked="" type="checkbox"/>	2.50 V
222.10	ChrgVtgFlo	Cell voltage setpoint for float charge in V (expert mode)	2.20 V to 2.40 V	-	<input checked="" type="checkbox"/>	<input checked="" type="checkbox"/>	2.25 V
222.11	BatTmpCps	Battery temperature compensation in $\text{mV}/^{\circ}\text{C}$ (expert mode)	0.0 $\text{mV}/^{\circ}\text{C}$ to 10.0 $\text{mV}/^{\circ}\text{C}$	-	<input checked="" type="checkbox"/>	<input checked="" type="checkbox"/>	4.0 $\text{mV}/^{\circ}\text{C}$
222.12	AutoEquChrgEna	Automatic equalization charge (expert mode)	Disable	Disable	<input checked="" type="checkbox"/>	<input checked="" type="checkbox"/>	Enable
			Enable	Enable			
222.13	BatChrgVtgMan	Manual setpoint of the battery charging voltage with disabled battery management in V (expert mode)	41.0 V to 63.0 V	-	<input checked="" type="checkbox"/>	<input checked="" type="checkbox"/>	54.0 V

223# Protection











No.	Name	Description	Value			Default Value
223.01	BatPro1TmStr	Start time of battery protection mode level 1 in hh:mm:ss (expert mode)	00:00:00 to 23:59:59	<input checked="" type="checkbox"/>	<input checked="" type="checkbox"/>	22:00:00
223.02	BatPro1TmStp	End time of battery protection mode level 1 in hh:mm:ss (expert mode)	00:00:00 to 23:59:59	<input checked="" type="checkbox"/>	<input checked="" type="checkbox"/>	06:00:00
223.03	BatPro2TmStr	Start time of battery protection mode level 2 in hh:mm:ss (expert mode)	00:00:00 to 23:59:59	<input checked="" type="checkbox"/>	<input checked="" type="checkbox"/>	17:00:00
223.04	BatPro2TmStp	End time of battery protection mode level 2 in hh:mm:ss (expert mode)	00:00:00 to 23:59:59	<input checked="" type="checkbox"/>	<input checked="" type="checkbox"/>	09:00:00
223.05	BatPro1Soc	Battery SOC for protection mode level 1 as % (expert mode)	0% to 70%	<input checked="" type="checkbox"/>	<input checked="" type="checkbox"/>	20 %
223.06	BatPro2Soc	Battery SOC for protection mode level 2 as % (expert mode)	0% to 70%	<input checked="" type="checkbox"/>	<input checked="" type="checkbox"/>	15 %

No.	Name	Description	Value	 	Default Value
223.07	BatPro3Soc	Battery SOC for protection mode level 3 as % (expert mode)	0% to 70%	 	10 %
223.08	BatProTmm	Minimum time (in minutes) during which there is no battery current for switching to battery protection mode (expert mode) If the minimum time has elapsed and no battery current was present, the Sunny Island can switch to battery protection mode.	1 min to 20 min	 	5 min

224# BatSilent



No.	Name	Description	Value	Explanation	 	Default value
224.01	BatSilentEna	Energy-saving mode	Enable	Enable	 	Disable
			Disable	Disable		
224.02	BatSilentTmFlo	Time until switchover to energy-saving mode (h)	1 h to 48 h	-	 	3 h
224.03	BatSilentTmMax	Maximum duration of energy-saving mode (h)	1 h to 168 h		 	12 h

225# Current Sensor



No.	Name	Description	Value	Explanation	 	Default value
225.01	BatCurSnsTyp	Type of battery current sensor	None	No sensor is connected.	 	None
			60 mV	60 mV type		
			50 mV	50 mV type		
225.02	BatCurGain60	60 mV type in $\frac{A}{60 \text{ mV}}$	0 $\frac{A}{60 \text{ mV}}$ to 1800 $\frac{A}{60 \text{ mV}}$	-	 	100 $\frac{A}{60 \text{ mV}}$
225.03	BatCurGain50	50 mV-Typ in $\frac{A}{50 \text{ mV}}$	0 $\frac{A}{50 \text{ mV}}$ to 1800 $\frac{A}{50 \text{ mV}}$	-	 	100 $\frac{A}{50 \text{ mV}}$
225.04	BatCurAutoCal	Automatic calibration of external battery current sensor	Start	Start automatic calibration	 	-



13.2.2.3 External/Backup (230#)



231# General



No.	Name	Description	Value	Explanation			Default Value
231.01	PvFeedTmStr	Start time for PV grid feed-in in hh:mm:ss (expert mode)	00:00:00 to 23:59:59	-	✗	✓	04:00:00
231.02	PvFeedTmStp	Stop time for PV grid feed-in in hh:mm:ss (expert mode)	00:00:00 to 23:59:59	-	✗	✓	22:00:00
231.03	ExtLkTm	Lock time until connection to the external grid after reverse power or relay protection in minutes (expert mode)	0 min to 60 min	-	✗	✓	20 min
231.06	ExtSrc	External energy sources in Off-Grid mode	PvOnly	Only AC sources in the stand-alone grid, no generator in the off-grid system	✗	✓	-
			Gen	Generator			
			Grid	Utility grid			
			GenGrid	Electric generator or utility grid			
231.12	ClstPwrNom	Nominal power of the cluster in kW	-	-	✓	✓	-



232# Grid Control



No.	Name	Description	Value	Explanation			Default Value
232.01	Country	Set country standard (protected by SMA Grid Guard)	Other	Individual setting	✓	✓	-
			VDE-AR-4105	Code of Practice VDE-AR-N 4105			-
			AS4777	Standard AS4777			
232.02	GdVtgMin	Lower minimum threshold of line voltage for voltage monitoring in V (expert mode, protected by SMA Grid Guard)	172.50 V to 210.01 InvVtgNom	230 V / 50 Hz	✓	✓	184.00 V
				220 V / 60 Hz			194.00 V



No.	Name	Description	Value	Explanation			Default Value
232.03	GdVtgMax	Upper maximum threshold of line voltage for voltage monitoring in V (expert mode, protected by SMA Grid Guard)	210.01 InvVtgNom to 264.50 V	230 V / 50 Hz	✓	✓	264.50 V
				220 V / 60 Hz			242.00 V
232.04	GdCurNom	Maximum current from the utility grid in A (expert mode)	0.0 A to 50.0 A	1 inverter SI 3.0M / 4.4M (single-phase)	✗	✓	16 A
				1 inverter SI 6.0H / 8.0H (single-phase)	✗	✓	16 A
				2 inverters SI 6.0H / 8.0H (single-phase)	✗	✓	16 A
				3 inverters SI 6.0H / 8.0H (single-phase)	✗	✓	16 A
				3 inverters SI 3.0M / 4.4M (three-phase)	✗	✓	16 A
				3 inverters SI 6.0H / 8.0H (three-phase)	✗	✓	16 A
232.05	GdFrqNom	Nominal grid frequency in Hz (expert mode, protected by SMA Grid Guard)	232.05 GdFrqMin to 232.06 GdFrqMax	230 V / 50 Hz	✓	✓	50.00 Hz
				220 V / 60 Hz			60.00 Hz
232.06	GdFrqMin	Lower minimum threshold of power frequency for frequency monitoring in Hz (expert mode, protected by SMA Grid Guard)	40.00 Hz to 232.04 GdFrqNom	230 V / 50 Hz	✓	✓	47.50 Hz
				220 V / 60 Hz			59.30 Hz
232.07	GdFrqMax	Upper maximum threshold of power frequency for frequency monitoring in Hz (expert mode, protected by SMA Grid Guard)	232.4 GdFrqNom to 70.00 Hz	230 V / 50 Hz	✓	✓	51.50 Hz
				220 V / 60 Hz			60.50 Hz

No.	Name	Description	Value	Explanation			Default Value
232.08	GdVldTm	Minimum observation time for line voltage and frequency in the permissible range for connection in s (expert mode, protected by SMA Grid Guard)	5 s to 900 s	VDE-AR-N 4105 AS4777	✓	✓	60 s
				220 V / 60 Hz			300 s
232.09	GdMod	Type of reverse feeding into the utility grid (expert mode, protected by SMA Grid Guard)	GridFeed	Charge and feed-back on utility grid If ApplSel was set to OnGrid in the QCG, the value GridFeed is fixed. If ApplSel was set to OffGrid in the QCG, GridFeed and GridCharge can be selected.	✓	✓	-
			GridCharge	Charge on utility grid			
232.10	GdRvPwr	Maximum grid reverse power in W (expert mode)	0 W to 5000 W	One Sunny Island or single-cluster system	✗	✓	100 W
			0 W to 20000 W	Multicluster system			100 W
232.11	GdRvTm	Permissible time for maximum grid reverse power in s (expert mode)	0 s to 60 s	-	✗	✓	5 s
232.12	GdVtgMinDel	Lower voltage difference for valid grid connection in V (expert mode, protected by SMA Grid Guard)	0.0 V to 20.0 V	VDE_AR_4105	✓	✓	11.5 V
				AS4777			2.0 V
				Off-grid			2.0 V
				Other			2.0 V
				220 V / 60 Hz			2.0 V
232.13	GdVtgMaxDel	Upper voltage difference for valid grid connection in V (expert mode, protected by SMA Grid Guard)	0.0 V to 12.0 V	VDE_AR_4105	✓	✓	11.5 V
				AS4777			2.0 V
				Off-grid			2.0 V
				Other			2.0 V
				220 V / 60 Hz			2.0 V



No.	Name	Description	Value	Explanation	 	Default Value
232.14	GdFrqMinDel	Lower frequency difference for valid grid connection in Hz (expert mode, protected by SMA Grid Guard)	0.00 Hz to 2.50 Hz	-	✓ ✓	0.02 Hz
232.15	GdFrqMaxDel	Upper frequency difference for valid grid connection in Hz (expert mode, protected by SMA Grid Guard)	0.00 Hz to 2.50 Hz	VDE_AR_4105	✓ ✓	1.45 Hz
			0.00 Hz to 0.20 Hz	230 V / 50 Hz		0.02 Hz
			0.00 Hz to 0.20 Hz	220 V / 60 Hz		0.02 Hz
232.16	GdAlSns	Sensitivity of the anti-islanding detection (expert mode, protected by SMA Grid Guard)	Low	Low	✓ ✓	Standard
			Medium	Medium		
			Standard	Standard		
			High	High		
232.40	GdRtCurSrc	Place of reactive current compensation in grid operation (expert mode)	External	Sunny Island compensates all reactive currents.	✓ ✗	External
			Inverter	Sunny Island does not compensate reactive currents.		
			Shared	Sunny Island partially compensates reactive currents.		
232.41	P-WCtHzMod	Operating mode of active power reduction in case of overfrequency P(f) (expert mode, protected by SMA Grid Guard)	Off	Disable	✓ ✓	-
			WCtHz	Enable		
232.42	P-HzStr	Difference between starting frequency and grid frequency, linear instantaneous power gradient configuration (protected by SMA Grid Guard)	0.0 Hz to 5.0 Hz	This value defines how many Hz above 210.02 InvFrqNom the active power limitation starts.	✓ ✗	0.2 Hz















No.	Name	Description	Value	Explanation			Default Value
232.43	P-HzStop	Difference between reset frequency and grid frequency, linear instantaneous power gradient configuration (protected by SMA Grid Guard)	0.0 Hz to 5.0 Hz	This values defines how many Hz above 210.02 InvFrqNom the active power limitation stops.	✓	✗	0.2 Hz
232.44	P-WGra	Active power gradient, linear instantaneous power gradient configuration (expert mode, protected by SMA Grid Guard)	10 %/Hz to 130 %/Hz	-	✓	✓	40%Hz
232.46	WGraRecon	Power gradient following grid error in % (expert mode, protected by SMA Grid Guard)	1% to 100%	-	✓	✓	10 %
232.48	Q-VArMod	Operating mode of static voltage stability, configuration of static voltage stability (expert mode, protected by SMA Grid Guard)	Off	Disable	✓	✓	-
			PFCnst	Constant displacement power factor $\cos \varphi$			
			PFCtIW	Automatic adaptation of the displacement power factor according to the current active power			
232.49	PF-PF	CosPhi setpoint, cosPhi configuration, direct specification (expert mode, protected by SMA Grid Guard)	0.8 to 1	Code of Practice VDE-AR-N 4105	✓	✓	0.9
				Norm AS-4777			1
232.50	PF-PFExt	CosPhi excitation type, cosPhi configuration, direct specification (expert mode, protected by SMA Grid Guard)	OvExt	Lagging	✓	✓	UnExt
			UnExt	Leading			
232.51	PF-PFStr	CosPhi of the start point, configuration of cos Phi(P) characteristic curve, direct specification (expert mode, protected by SMA Grid Guard)	0.8 to 1	-	✓	✓	1

No.	Name	Description	Value	Explanation	 	Default Value
232.52	PF-PFExtStr	Excitation type of the start point, configuration of cos Phi(P) characteristic curve, direct specification (expert mode, protected by SMA Grid Guard)	OvExt	Lagging	✓ ✓	OvExt
			UnExt	Leading		
232.53	PF-WNomStr	Active power of the start point, configuration of cos Phi(P) characteristic curve, direct specification (expert mode, protected by SMA Grid Guard)	0% to 232.56 PF-WNomStop	-	✓ ✓	50 %
232.54	PF-PFStop	CosPhi of the end point, configuration of cos Phi(P) characteristic curve, direct specification (expert mode, protected by SMA Grid Guard)	0.8 to 1.0	-	✓ ✓	0.9
232.55	PF-PFExtStop	Excitation type of the end point, configuration of cos Phi(P) characteristic, direct specification (expert mode, protected by SMA Grid Guard)	OvExt	Lagging	✓ ✓	UnExt
			UnExt	Leading		
232.56	PF-WNomStop	Active power of the end point, configuration of cos Phi(P) characteristic curve, direct specification (expert mode, protected by SMA Grid Guard)	232.52 PF-WNomStr to 100%	-	✓ ✓	100 %
232.58	GdAlFac	Anti-islanding factor in current-controlled grid operation with I-Loop (expert mode)	0.00 to 3.00	-	✓ ✓	0.50
232.59	MsPhSel	Line conductor to which the Sunny Island is connected (expert mode, protected by SMA Grid Guard)	L1	Line conductor L1	✓ ✗	-
			L2	Line conductor L2		
			L3	Line conductor L3		







No.	Name	Description	Value	Explanation			Default Value
232.60	EZATyp	Type of PV system feed-in (expert mode, protected by SMA Grid Guard)	Symmetric	All PV inverters are three-phase and feed in symmetrically.	✓	✗	-
			Asymmetric	At least one PV inverter is single-phase and feeds in asymmetrically.			



















233# Grid Start, for Off-Grid Systems Only



No.	Name	Description	Value	Explanation			Default Value
233.01	GdSocEna	Enable grid request based on battery state of charge (expert mode)	Disable	Disable	✗	✓	Disable
			Enable	Enable			
233.02	GdSocTm1Str	Battery state of charge limit for connection to the utility grid in the standard additional time period in % (expert mode) This is the valid threshold without the additional time period.	1% to 233.03 GdSocTm1Stp	-	✗	✓	40 %
233.03	GdSocTm1Stp	Battery state of charge limit for disconnection from the utility grid in the standard additional time period as % (expert mode) This is the valid threshold without the additional time period.	233.02 GdSocTm1Str to 95%	-	✗	✓	80 %
233.04	GdSocTm2Str	Battery state of charge limit for connection to the utility grid in the additional time period as % (expert mode)	1% to 233.05 GdSocTm2Stp	-	✗	✓	40 %
233.05	GdSocTm2Stp	Battery state of charge limit for disconnection from the utility grid in the additional time period as % (expert mode)	233.04 GdSocTm2Str to 95%	-	✗	✓	80 %

No.	Name	Description	Value	Explanation			Default Value
233.06	GdTm1Str	Start of standard additional time period for grid request in hh:mm:ss (expert mode)	00:00:00 to 23:59:59	-			-
233.07	GdTm2Str	Start of additional time period for grid request in hh:mm:ss (expert mode)	00:00:00 to 23:59:59	-			-
233.08	GdPwrEna	Grid request based on power (expert mode)	Disable Enable	Disable Enable			Disable
233.09	GdPwrStr	Grid request for connection power limit in kW (expert mode)	233.10 GdPwrStp to 300 kW	-			4.0 kW
233.10	GdPwrStp	Grid request for disconnection power limit in kW (expert mode)	0 kW to 233.09 GdPwrStr	-			2.0 kW
233.11	GdStrChrgMod	Grid request based on charge mode (expert mode)	Off Full Equal Both	Off Full charge Equalization charge Full and equalization charge			Equal

234# Gen Control

No.	Name	Description	Value	Explanation			Default Value
234.01	GnVtgMin	Lower minimum threshold of PV array voltage for voltage monitoring in V (expert mode)	172.5 V to 210.01 InvVtgNom	-			172.50 V
234.02	GnVtgMax	Upper maximum threshold of PV array voltage for voltage monitoring in V (expert mode, protected by SMA Grid Guard)	210.01 InvVtgNom to 264.5 V	-			250.0 V

No.	Name	Description	Value	Explanation			Default Value
234.03	GnCurNom	Nominal generator current in A	0.0 A to 50.0 A	1 Sunny Island			16.0 A
			0.0 A to 100.0 A	Two Sunny Island inverters, parallel			16.0 A
			0.0 A to 150.0 A	Three Sunny Island inverters, parallel			16.0 A
			0.0 A to 50.0 A	Three-phase			16.0 A
			0.0 A to 80.0 A	Multicluster-Box 6			60.0 A
			0.0 A to 160.0 A	Multicluster-Box 12 (MC-BOX-12.3)			160.0 A
			0.0 A to 200.0 A	Multicluster-Box 12 (MC-BOX-12.3-20)			200.0 A
		0.0 A to 500.0 A	Multicluster-Box 36	435.0 A			
234.04	GnFrqNom	Nominal generator frequency under nominal load in Hz (expert mode)	234.05 GnFrqMin to 234.06 GnFrqMax	230 V / 50 Hz			50.00 Hz
				220 V / 60 Hz			60.00 Hz
234.05	GnFrqMin	Lower minimum threshold of generator frequency for frequency monitoring in Hz (expert mode)	40.00 Hz to 234.04 GnFrqNom	230 V / 50 Hz			44.64 Hz
			50.00 Hz to 234.04 GnFrqNom	220 V / 60 Hz			50.00 Hz
234.06	GnFrqMax	Upper maximum threshold of generator frequency for frequency monitoring in Hz (expert mode, protected by SMA Grid Guard)	234.04 GnFrqNom to 70.00 Hz	230 V / 50 Hz			60.00 Hz
				220 V / 60 Hz			70.00 Hz
234.07	GnStrMod	Generator interface	Manual Autostart	Manual Automatic			Autostart
234.08	GnOpTmMin	Minimum run time of generator in minutes	0 min to 360 min	-			15 min
234.09	GnStpTmMin	Minimum stop time of the generator in minutes	0 min to 360 min	-			15 min
234.10	GnCoolTm	Cooling time of the generator in minutes	0 min to 60 min	-			5 min

No.	Name	Description	Value	Explanation			Default Value
234.11	GnErrStpTm	Idle time after generator error in hours (expert mode)	0 h to 24 h	-	✗	✓	1 h
234.12	GnWarmTm	Warm-up time in seconds	5 s to 900 s	-	✗	✓	60 s
234.13	GnRvPwr	Maximum reverse power for voltage monitoring of generator in W (expert mode)	0 W to 5000 W	One Sunny Island or single-cluster system	✗	✓	100 W
			0 W to 20000 W	Multicluster system			100 W
234.14	GnRvTm	Time for reverse power or reverse current for voltage monitoring of generator in s (expert mode)	0 s to 900 s	-	✗	✓	30 s
234.15	GnCtlMod	Type of generator current limitation (expert mode)	Cur	Fixed threshold for current limitation	✗	✓	Cur
		The generator control limits the consumption of generator current.	CurFrq	Frequency-dependent current limitation			
234.20	GnAISns	Anti-islanding Sensitivity of the generator fault recognition (expert mode)	Low	Low	✗	✓	Standard
			Medium	Medium			
			Standard	Standard			
			High	High			
234.41	GnCurCtlMod	Enable I-Loop in generator operation (expert mode, only with SI6.0H-11 and SI8.0H-11) I-Loop enables generators with inadequate voltage regulation to be used in the system.	Droop	Standard generator operation without I-Loop	✗	✓	Droop
			CurCtl	Current-controlled generator operation with I-Loop			
234.42	GnAlFac	Anti-islanding factor in current-controlled generator operation with I-Loop (expert mode)	0.00 to 1.00	-	✗	✓	0.10



235# Gen Start

No.	Name	Description	Value	Explanation			Default Value
235.01	GnAutoEna	Automatic restart of generator in the event of disturbance	Off	Disable			On
			On	Enable			
235.02	GnAutoStr	Number of attempts to carry out automatic restart of generator (expert mode)	0 to 10	-			3
235.03	GnSocTm1Str	Battery state of charge limit for generator request in the standard additional time period as % This is the valid threshold without the additional time period.	1% to 235.04 GnSocTm1Stp	-			40 %
235.04	GnSocTm1Stp	Battery state of charge limit for end of generator request in the standard additional time period as % This is the valid threshold without the additional time period.	235.03 GnSocTm1Str to 95%	-			80 %
235.05	GnSocTm2Str	Battery state of charge limit for generator request in additional time period as %	1% to 235.06 GnSocTm2Stp	-			40 %
235.06	GnSocTm2Stp	Battery state of charge limit for end of generator request in the additional time period as %	235.05 GnSocTm2Str to 95%	-			80 %
235.07	GnTm1Str	Start time of the standard additional time period for generator request in hh:mm:ss; corresponds to the end time of the additional time period	00:00:00 to 23:59:59	-			00:00:00
235.08	GnTm2Str	Start time of additional time period for generator request in hh:mm:ss	00:00:00 to 23:59:59	-			00:00:00
235.09	GnPwrEna	Generator request based on power (expert mode)	Disable	Disable			Enable
			Enable	Enable			

No.	Name	Description	Value	Explanation			Default Value
235.10	GnPwrStr	Load limit: Generator start for generator request based on power in kW (expert mode)	235.11 GnPwrStp to 300.0 kW	-			4.0 kW
235.11	GnPwrStp	Load limit: Generator shutdown for end of generator request based on power in kW (expert mode)	0.0 kW to 235.10 GnPwrStr	-			2.0 kW
235.12	GnPwrAvgTm	Averaging time for load-dependent generator request based on power in s (expert mode)	1 s to 900 s	-			60 s
235.13	GnTmOpEna	Time-controlled generator operation	Disable Enable	Disable Enable			Disable
235.14	GnTmOpStrDt	Start date for time-controlled generator operation in dd.mm.yyyy	-	-			2011-01-01
235.15	GnTmOpStrTm	Time at the start of time-controlled generator operation in hh:mm:ss	00:00:00 to 23:59:59	-			00:00:00
235.16	GnTmOpRnDur	Run time for time-controlled generator operation in hh:mm:ss	00:00:00 to 99:59:00	-			00:00:00
235.17	GnTmOpCyc	Repeat cycle for time-controlled generator operation	Single Daily Weekly	Once Daily Weekly			Single
235.18	GnStrChrgMod	Generator request in configured charge mode (expert mode)	Off Full Equal Both	Off Full charge Equalization charge Full and equalization charge			Both
235.19	GnStrDigIn	Generator request in response to signal on activated digital input (expert mode)	Disable Enable	Disable Enable			Disable

13.2.2.4 Relay (240#)

241# General

No.	Name	Description	Value	Explanation			Default Value
241.01	Rly1Op	Operating mode of the multifunction relay 1	Value and description see following table 241.01 Rly1Op: Operating mode of the multifunction relay 1		✓	✓	AutoGn
241.02	Rly2Op	Multifunction relay 2 function	Value and description see following table 241.01 Rly1Op: Operating mode of the multifunction relay 1		✓	✓	AutoLodExt
241.07	ExtPwrDerMinTm	Minimum time for ExtPwrDer of the multifunction relays in minutes	0 min to 600 min		✓	✓	10 min
241.08	ExtPwrDerDltVtg	Voltage difference for the ExtPwrDer function of the multifunction relay in V The voltage difference corresponds to the cell voltage of the battery.	0 V to 0.40 V		✓	✓	0.15 V

241.01 Rly1Op: Operating mode of the multifunction relay 1

Value	Explanation
Off	Off; the multifunction relay is always in idle mode.
On	On; the multifunction relay is permanently activated.
AutoGn	Automatic generator request: the Sunny Island automatically requests the generator. In the event of a generator request, the multifunction relay is activated.
AutoLodExt	1-level load shedding When the generator is connected, the Sunny Island stops the load shedding. When the loads are to be shed, the multifunction relay is deactivated.
AutoLod1Soc	1-level load shedding or first level of 2-level load shedding When the upper SOC threshold is reached, the Sunny Island ends load shedding. When the loads are to be shed, the multifunction relay is deactivated.
AutoLod2Soc	Second level of 2-level load shedding When the upper SOC threshold is reached, the Sunny Island ends load shedding. When the loads are to be shed, the multifunction relay is deactivated.
Tm1	Timer 1 The Sunny Island controls external processes time-dependently. When the set time #243 Timer is reached, the multifunction relay is activated.

241.01 Rly1Op: Operating mode of the multifunction relay 1



Value	Explanation
Tm2	Timer 2 The Sunny Island controls external processes time-dependently. When the set time #243 Timer is reached, the multifunction relay is activated.
ExtPwrDer	Control of additional loads: the Sunny Island controls additional loads in order to put excess energy to practical use. When excessive energy can be used, the multifunction relay is activated.
GnRn	Relay is activated when generator is running: When the generator is in operation, the multifunction relay is activated.
ExtVfOk	Relay is activated when external source is present: When the voltage and frequency of the external energy source are within the valid range for the connection, the multifunction relay is activated.
GdOn	Relay is activated when utility grid is present: When the utility grid is connected, the multifunction relay is activated.
Error	Relay is deactivated during error: When an error message is pending, the multifunction relay is deactivated.
Warn	Relay is activated during warning: When a warning is pending, the multifunction relay is activated.
Run	Relay is activated when cluster is running: When the Sunny Island or the cluster is in operation, the multifunction relay is activated.
BatFan	Relay is activated when battery room fan is running: The Sunny Island controls the battery room fan for all clusters together. When the battery room is to be ventilated, the multifunction relay is activated.
AcdCir	Relay is activated when the electrolyte pump is running: The Sunny Island controls the electrolyte pump of the battery. When the electrolyte is to be circulated, the multifunction relay is activated.
MccBatFan	Relay is activated when battery room fan is running: The Sunny Island controls the battery room fan for all clusters together. When the battery room is to be ventilated, the multifunction relay is activated.
MccAutoLod	Load shedding in a multicluster system When all batteries have reached the upper SOC threshold, the Sunny Island ends load shedding. When the loads are to be shed, the multifunction relay is deactivated.
CHPReq	No function
CHPAdd	No function
SiComRemote	Multifunction relay is controlled via ComSync.
Overload	When the Sunny Island limits its power, the multifunction relay is deactivated.
GriSwT	Triggering of contactors for grid disconnection in the battery backup system

241.01 Rly1Op: Operating mode of the multifunction relay 1



Value	Explanation
GndSwT	Triggering of the grounding in the battery backup system
GriRdtSwT	Triggering of redundant contactor for grid disconnection in the battery backup system

242# Load



No.	Name	Description	Value			Default Value
242.01	Lod1SocTm1Str	Battery state of charge limit for start of load shedding 1 in the standard additional time period as % This is the valid threshold without the additional time period.	1% to 242.02 Lod1SocTm1Stp	✓	✓	30 %
242.02	Lod1SocTm1Stp	Battery state of charge limit for end of load shedding 1 in the standard additional time period as % This is the valid threshold without the additional time period.	242.01 Lod1SocTm1Str to 90%	✓	✓	50 %
242.03	Lod1SocTm2Str	Battery state of charge limit for start of load shedding 1 in additional time period as %	1% to 242.04 Lod1SocTm2Stp	✓	✓	30 %
242.04	Lod1SocTm2Stp	Battery state of charge limit for end of load shedding stop in additional time period as %	242.03 Lod1SocTm2Str to 90%	✓	✓	50 %
242.05	Lod1Tm1Str	Start time of the standard additional time period for load shedding 1 in hh:mm:ss; corresponds to the end time of the additional time period	00:00:00 to 23:59:59	✓	✓	-
242.06	Lod1Tm2Str	Start time of the additional time period for load shedding 1 in hh:mm:ss	00:00:00 to 23:59:59	✓	✓	-
242.07	Lod2SocTm1Str	Battery state of charge limit for start of load shedding 2 in the standard additional time period as % This is the valid threshold without the additional time period.	1% to 242.08 Lod2SocTm1Stp	✓	✓	30 %
242.08	Lod2SocTm1Stp	Battery state of charge limit for end of load shedding 2 in the standard additional time period as % This is the valid threshold without the additional time period.	242.07 Lod2SocTm1Str to 90%	✓	✓	50 %
242.09	Lod2SocTm2Str	Battery state of charge limit for start of load shedding 2 in the standard additional time period as %	1% to 242.10 Lod2SocTm2Stp	✓	✓	30 %

No.	Name	Description	Value			Default Value
242.10	Lod2SocTm2Stp	Battery state of charge limit for end of load shedding 2 in additional time period as %	242.09 Lod2SocTm2Str to 90%	✓	✓	50 %
242.11	Lod2Tm1Str	Start time of the standard additional time period for load shedding 2 in hh:mm:ss; corresponds to the end time of the additional time period	00:00:00 to 23:59:59	✓	✓	00:00:00
242.12	Lod2Tm2Str	Start time of the additional time period for load shedding 2 in hh:mm:ss; corresponds to the start time of the additional time period	00:00:00 to 23:59:59	✓	✓	00:00:00



243# Timer

No.	Name	Description	Value	Explanation			Default Value
243.01	RlyTmr1StrDt	Start date for timer 1 in dd.mm.yyyy	-	-	✓	✓	2011-01-01
243.02	RlyTmr1StrTm	Start time at which the multifunction relay is activated for timer 1 in hh:mm:ss	00:00:00 to 23:59:59	-	✓	✓	-
243.03	RlyTmr1Dur	Duration for which the multifunction relay remains activated for timer 1 in hh:m-m:ss	00:00:00 to 99:59:00	-	✓	✓	-
243.04	RlyTmr1Cyc	Repetition cycle time for timer 1	Single Daily Weekly	Once Daily Weekly	✓	✓	Single
243.05	RlyTmr2StrDt	Start date timer 2	-	-	✓	✓	2011-01-01
243.06	RlyTmr2StrTm	Start time at which the multifunction relay is activated for timer 2 in hh:mm:ss	00:00:00 to 23:59:59	-	✓	✓	-
243.07	RlyTmr2Dur	Duration for which the multifunction relay remains activated for timer 2 in hh:m-m:ss	00:00:00 to 99:59:00	-	✓	✓	-
243.08	RlyTmr2Cyc	Repetition cycle time for timer 2	Single Daily Weekly	Once Daily Weekly	✓	✓	Single



244# Slave1



No.	Name	Description	Value	Explanation			Default Value
244.01	Rly1Op Slv1	Operating mode of the multifunction relay 1 of slave 1	Value and explanation see 241.01 Rly1Op		✓	✓	Off
244.02	Rly2Op Slv1	Operating mode of the multifunction relay 2 of slave 1	Value and explanation see 241.01 Rly1Op		✓	✓	Off



245# slave2

No.	Name	Description	Value	Explanation			Default Value
245.01	Rly1Op Slv2	Operating mode of the multifunction relay 1 of slave 2	Value and explanation see 241.01 Rly1Op		✓	✓	Off
245.02	Rly2Op Slv2	Operating mode of the multifunction relay 2 of slave 2	Value and explanation see 241.01 Rly1Op		✓	✓	Off

13.2.2.5 System (250#)



No.	Name	Description	Value	Explanation			Default Value
250.01	AutoStr	Number of autostarts	0 to 10	0 indicates that autostart is disabled.	✓	✓	3
250.02	Dt	Date in dd.mm.yyyy	-	-	✓	✓	-
250.03	Tm	Time in hh:mm:ss	-	-	✓	✓	-
250.04	BeepEna	Button sound	Off On	Disable Enable	✓	✓	On
250.06	ComBaud	Baud rate in Bd This value cannot be changed with Speedwire.	1200 4800 9600 19200 115k	Default value for RS485 communication. - - - Default value for Speedwire communication.	✓	✓	-



No.	Name	Description	Value	Explanation	 	Default Value
250.09	ComAdr	Communication address (non-adjustable)	0 to 65535	-	✓ ✓	1
250.11	AfraEna	Automatic frequency synchronization (AFRA) (expert mode)	Disable	Disable	✗ ✓	-
			Enable	Enable		
250.23	Box	Type of AC subdistribution: / Multicluster-Box	None	None	✗ ✓	-
			MC-Box-6-1x	Multicluster-Box 6.3		
			MC-Box-9-1x	Multicluster-Box 9.3		
			MC-Box-12-1x	Multicluster-Box 12.3		
			MC-Box-12-2x	Multicluster-Box 12.3 of the type MC-BOX-12.3-20		
			MC-Box-36-1x	Multicluster-Box 36.3		
250.24	ClstMod	Cluster type (adjustable in QCG)	SingleClst	Single cluster	✓ ✓	-
			MainClst	Main cluster		
			ExtnClst	Extension cluster		
250.28	ChrgCtlOp	Type: other DC sources (expert mode)	Auto	AC sources and DC charge controllers	✗ ✓	Auto
			NoFrq	Other DC charge controllers The DC charge controllers are not Sunny Island Charger devices and there are no AC sources in the system.		
			SMA	Communicative coupled DC charge controllers, e.g. Sunny Island Charger No AC sources in the system.		
250.30	RnMod	Run Mode Behavior of the cluster in the event of a device fault	RunAlways	In the event of a slave device error, the cluster remains in operation	✓ ✓	RunAlways
			StopAlways	In the event of a device error, the cluster stops operation		

No.	Name	Description	Value	Explanation	 	Default Value
250.31	ChLstSel	Selection of short or normal channel list (expert mode) The length must be compatible with the communication device.	Short	Short	✓ ✓	Standard
			Standard	Standard		
250.32	UpdMode	Type of firmware update	Manual	Update must be confirmed on the Sunny Remote Control.	✓ ✓	Manual
			Auto	Update will be performed automatically at the set time 250.33 UpdAutoTime .		
			Never	Deactivation of all updates		
250.33	UpdAutoTime	Point in time for performing the automatic firmware update in hh:mm:ss	00:00:00 to 23:59:59	-	✓ ✗	05:00:00

13.2.2.6 SlfCsmBackup (#260)



261# General



No.	Name	Description	Value	Explanation	 	Default Value
261.01	SlfCsm-plncEna	Increased self-consumption	Disable	Disable	✓ ✗	-
			Enable	Enable	✓ ✗	
261.02	SlfCsmPosSel	Highest-yielding month for battery utilization range:	North	Highest PV yield in June	✓ ✗	-
			South	Highest PV yield in December	✓ ✗	
261.03	Saisonenable	Seasonal operation (expert mode) Automatic adjustment of the battery depth of discharge: In seasons with fewer hours of sunlight, the electric discharge of the battery will be lower.	No	Disable	✓ ✗	Yes
			Yes	Enable	✓ ✗	

No.	Name	Description	Value	Explanation	 	Default Value
261.04	SlfCsmSpnt	Specification of the control target at active self-consumption in W*	≤ 0 W	Negative value: grid feed-in	✓ ✗	0 W
			0 W	No grid feed-in and purchased electricity		
			≥ 0 W	Positive value: purchased electricity		
261.05	SlfCsm-pLodShed	Activation of load shedding during self-consumption.*	Disable	Load shedding during self-consumption is deactivated.	✓ ✗	Enable
			Enable	Load shedding during self-consumption is activated.		

* The parameter is visible until firmware version 3.5 of the Sunny Island. Firmware version 3.5 of Sunny Island can only be used in multicuster systems with the Multicuster-Box 12 of device type MC-BOX-12.3-20.

262# BatUsage



No.	Name	Description	Value	Explanation	 	Default Value
262.01	ProtResSOC	Lower limit of the deep-discharge protection range for disconnection (%) of the battery capacity (expert mode)	10% to 20%	Lead-acid batteries	✓ ✗	10 %
			3% to 20%	Lithium-ion batteries	✓ ✗	3 %
262.02	BatResSOC	Minimum width of the deep-discharge protection range (%) of the battery capacity (expert mode)	2% to 50%	Lithium-ion battery, self-consumption only	✓ ✗	2 %
				Lithium-ion battery, battery backup system	✓ ✗	10 %
				Lead-acid battery, self-consumption only	✓ ✗	30 %
				Lead-acid battery, battery backup system	✓ ✗	5 %
262.03	BUResSOC	Minimum width of the backup power supply range on the longest day of the year as a percentage of the battery capacity (expert mode)	0% to 100%	-	✓ ✗	0 %

No.	Name	Description	Value	Explanation	 	Default Value
262.04	PVResSOC	Width of the range for the maintenance of the battery state of charge (%) of the nominal capacity (expert mode)	4% to 20%	-	<input checked="" type="checkbox"/> <input checked="" type="checkbox"/>	5 %
262.05	MinSlfCsm- pSOC	Minimum width of the self-consumption range on the shortest day of the year as a percentage of the battery capacity (expert mode)	0% to 91%	Lithium-ion battery	<input checked="" type="checkbox"/> <input checked="" type="checkbox"/>	70 %*
				Lead-acid battery	<input checked="" type="checkbox"/> <input checked="" type="checkbox"/>	35 %**

* The setting of the parameter **262.05 MinSlfCsm-pSOC** to 70% for lithium-ion batteries corresponds to a discharge of 30% until the SOC is reached (see **120.01 BatSoc**).

** The setting of the parameter **262.05 MinSlfCsm-pSOC** to 35% for lead-acid batteries corresponds to a discharge of 65% until the SOC is reached (see **120.01 BatSoc**).



13.2.2.7 Authent (270#)

No.	Name	Description	 
270.01	Auth.Code	Entry of the SMA Grid Guard code	<input checked="" type="checkbox"/> <input checked="" type="checkbox"/>



13.2.3 Information (300#)

13.2.3.1 Inverter (310#)



311# Total

No.	Name	Description	 
311.01	EgyCntIn	Energy consumed by the Sunny Island inverter in kWh	<input checked="" type="checkbox"/> <input checked="" type="checkbox"/>
311.02	EgyCntOut	Energy supplied by the Sunny Island inverter in kWh	<input checked="" type="checkbox"/> <input checked="" type="checkbox"/>
311.03	EgyCntTm	Energy metering run time in hours	<input checked="" type="checkbox"/> <input checked="" type="checkbox"/>



312# Device

No.	Name	Description	Value (Plain text no.)	Explanation	 
312.01	Adr	Device address	Master (1)	Address	<input checked="" type="checkbox"/> <input checked="" type="checkbox"/>
			Slave1 (2)	Address	
			Slave2 (3)	Address	

No.	Name	Description	Value (Plain text no.)	Explanation		
312.03	ApplSel	Operating mode of the Sunny Island (expert mode)	Offgrid	Sunny Island is operating in the stand-alone grid.	✓	✓
			OnGrid	Sunny Island is connected to the utility grid.		
312.05	SysFncSel	Selection of the on-grid system (expert mode)	SelfConsOnly	Increased self-consumption only	✓	✗
			BackupOnly	Battery backup only		
			SelfConsBackup	Battery backup with increased self-consumption		
312.06	FwVer	Firmware version of the central processing unit of the master	-	-	✓	✓
312.07	SN	Serial number of the master	-	-	✓	✓
312.08	OnTmh	Operating hours	-	-	✓	✓
312.09	ClstCfgAt	Set configuration of cluster	1Phase1	Single-phase, one Sunny Island	✓	✓
			1Phase2	Single-phase, two Sunny Island inverters		
			1Phase3	Single-phase, three Sunny Island inverters		
			3Phase	Three-phase, three Sunny Island inverters		
312.10	OpStt	Operating state of the Sunny Island inverter	Operating (1)	Operation	✓	✓
			Warning (2)	Warning		
			Failure (3)	Error		
312.11	CardStt	SD memory card status message	Off (1)	No SD memory card inserted	✓	✓
			Operational (2)	Ready for operation		
			Mount (3)	Initialization		
			OutOfSpace (4)	No storage space available		
			BadFileSys (5)	No file system detected		
			Incomp (6)	File system incompatible		
			Parameter (7)	Parameter set write access		
			ParamFailed (8)	Parameter set write access failed		
			WriteLogData (9)	Log data write access		

No.	Name	Description	Value (Plain text no.)	Explanation		
312.12	FwVer2	Firmware version of the logic component (digital signal processor)	-	-	✓	✓
312.13	FwVer3	Boot loader of the operation control unit	-	-	✓	✓
312.14	FwVer4	Boot loader of the digital signal processor	-	-	✓	✓
312.18	ComMod1	Type of interface in the interface slot SiSysCan	-	No interface inserted	✗	✓
			SI-SysCan	SI-SYSCAN.BGx inserted (multicluster system)		
312.19	ComMod2	Type of interface in the interface slot SiComSma	-	No interface inserted	✓	✓
			SI-ComSma	SI-COMSMA.BGx inserted (RS485)		
			SI-SW-DM	SWDMSI-NR inserted (Speedwire)		
312.21	Mm-cUpdFmVer	OCU firmware version of the update file on the SD memory card	-	-	✓	✓
312.22	Mm-cUpdFmVer 2	DSP firmware version of the update file on the SD memory card	-	-	✓	✓
312.23	MmcFileSys	File system of the SD memory card	FAT16	-	✓	✓
			FAT32	-		

313# Slave1

No.	Name	Description	Value	Explanation		
313.01	FwVerSlv1	Firmware version of slave 1	-	-	✓	✓
313.02	SNSlv1	Serial number of slave 1 (line conductor 2)	-	-	✓	✓
313.03	OnTmhSlv1	Operating hours of slave 1 in hours	-	-	✓	✓
313.04	PhSlv1	Line conductor assignment of slave 1	L1	Line conductor L1	✓	✓
			L2	Line conductor L2		
			L3	Line conductor L3		

No.	Name	Description	Value	Explanation		
313.05	OpSttSlv1	Operating state of slave 1 (line conductor 2)	Operating	Operation	✓	✓
			Warning	Warning		
			Failure	Error		
313.06	FwVer2Slv1	DSP firmware version of slave 1	-	-	✓	✓
313.07	FwVer3Slv1	OCU boot loader of slave 1	-	-	✓	✓
313.08	FwVer4Slv1	DSP boot loader of slave 1	-	-	✓	✓



314# Slave2

No.	Name	Description	Value	Explanation		
314.01	FwVerSlv2	Firmware version of slave 2	-	-	✓	✓
314.02	SNSlv2	Serial number of slave 2 (line conductor 3)	-	-	✓	✓
314.03	OnTmhSlv2	Operating hours of slave 2 in hours	-	-	✓	✓
314.04	PhSlv2	Line conductor assignment of slave 2	L1	Line conductor L1	✓	✓
			L2	Line conductor L2		
			L3	Line conductor L3		
314.05	OpSttSlv2	Operating state of slave 2 (line conductor 3)	Operating	Operation	✓	✓
			Warning	Warning		
			Failure	Error		
314.06	FwVer2Slv2	Firmware version of the digital signal processor of slave 2	-	-	✓	✓
314.07	FwVer3Slv2	Boot loader of the operation control unit of slave 2	-	-	✓	✓
314.08	FwVer4Slv2	Boot loader of the digital signal processor of slave 2	-	-	✓	✓

13.2.3.2 Battery (320#)



No.	Name	Description		
320.01	Soh	Usable battery capacity (SOH) in %	✓	✓
		Ratio of currently usable capacity to the rated value of the battery		
320.02	StatTm	Run time of statistics counter in days	✓	✓
320.03	ChrgFact	Charging factor	✓	✓
320.04	BatEgyCntln	Energy meter for battery charging in kWh	✓	✓

No.	Name	Description		
320.05	BatEgyCntOut	Energy meter for battery discharging in kWh	✓	✓
320.06	AhCntIn	Battery charging counter in Ah	✓	✓
320.07	AhCntOut	Battery discharging counter in Ah	✓	✓
320.08	BatTmpPkMin	Minimum battery temperature [°C]	✓	✓
320.09	BatTmpPkMax	Maximum battery temperature °C	✓	✓
320.10	EquChrgCnt	Number of equalization charges of the battery	✓	✓
320.11	FulChrgCnt	Number of full charges of the battery	✓	✓
320.12	BatCurOfsErr	Estimated offset error of battery current in A (expert mode)	✓	✓
320.13	OcvPointCnt	Open-circuit voltage points meter (expert mode)	✓	✓
320.15	AhCntFul	Relative battery discharging since the last full charge in $\frac{\text{Ah}}{100 \text{ Ah}}$	✓	✓
320.16	AhCntEqu	Ampere-hour meter for battery discharging since the last equalization charge in $\frac{\text{Ah}}{100 \text{ Ah}}$	✓	✓
320.17	BatVtgPk	Maximum battery voltage reached since the last start in V	✓	✓
320.18	BatCurPkIn	Maximum battery current reached since the last start in charge direction in A	✓	✓
320.19	BatCurPkOut	Maximum battery current reached since the last start in discharge direction in A	✓	✓
320.20	SocHgm100	Percentage frequency distribution of state of charge (SOC) when SOC is in the range of 100% to and including 90%, based on time in % (expert mode)	✓	✓
320.21	SocHgm090	Percentage frequency distribution of state of charge (SOC) when SOC is in the range of 90% to and including 80%, based on time in % (expert mode)	✓	✓
320.22	SocHgm080	Percentage frequency distribution of state of charge (SOC) when SOC is in the range of 80% to and including 70%, based on time in % (expert mode)	✓	✓
320.23	SocHgm070	Percentage frequency distribution of state of charge (SOC) when SOC is in the range of 70% to and including 60%, based on time in % (expert mode)	✓	✓
320.24	SocHgm060	Percentage frequency distribution of state of charge (SOC) when SOC is in the range of 60% to and including 50%, based on time in % (expert mode)	✓	✓
320.25	SocHgm050	Percentage frequency distribution of state of charge (SOC) when SOC is in the range of 50% to and including 40%, based on time in % (expert mode)	✓	✓
320.26	SocHgm040	Percentage frequency distribution of state of charge (SOC) when SOC is in the range of 40% to and including 30%, based on time in % (expert mode)	✓	✓
320.27	SocHgm030	Percentage frequency distribution of state of charge (SOC) when SOC is in the range of 30% to and including 20%, based on time in % (expert mode)	✓	✓
320.28	SocHgm020	Percentage frequency distribution of state of charge (SOC) when SOC is in the range of 20% to and including 10%, based on time in % (expert mode)	✓	✓
320.29	SocHgm010	Percentage frequency distribution of state of charge (SOC) when SOC is in the range of 10% to and including 0%, based on time in % (expert mode)	✓	✓



No.	Name	Description		
320.30	SocHgm000	Frequency distribution of SOC in relation to time, when SOC is equal to 0%, in % (expert mode)	✓	✓
320.31	SocVtgCal	Recalibration of SOC based on open-circuit voltage only in % (expert mode)	✓	✓
320.32	ErrSocVtgCal	Estimated error of the voltage-calibrated state of charge in % (expert mode)	✓	✓
320.33	SocChrgCal	Recalibration of SOC based on full charge only in % (expert mode)	✓	✓
320.34	ErrSocChrgCal	Estimated error of the full charge calibrated state of charge in % (expert mode)	✓	✓
320.35	OcvGra	Gradient of the open-circuit voltage characteristic curve in $\frac{Ah}{V}$ (expert mode)	✓	✓
320.36	OcvMax	Maximum open-circuit voltage in V (expert mode)	✓	✓
320.37	ExtBMSBatTyp	External battery management: battery type	✓	✓
320.38	ExtBMSBatCpyNom	External battery management: nominal battery capacity	✓	✓
320.39	ExtBMSFWVer	External battery management: version number of software	✓	✓
320.40	ExtBMSManID	External battery management: manufacturer identification	✓	✓

13.2.3.3 External (330#)

331# Grid

No.	Name	Description		
331.01	GdEgyCntIn	Energy meter for grid feed-in in kWh	✓	✓
331.02	GdEgyCntOut	Energy meter for purchased electricity in kWh	✓	✓
331.03	GdEgyTmh	Duration for which energy exchange with the utility grid is possible, in hours	✓	✓
331.04	GdOpTmh	Operating hours counter for grid operation in hours	✓	✓
331.05	GdCtcCnt	Number of grid connections	✓	✓
331.06	TotTmh	Feed-in hours	✓	✓
331.07	GdFailTms	Power outage time (s)	✓	✓

332# Generator

No.	Name	Description		
332.01	GnEgyCnt	Released energy from generator in kWh	✗	✓
332.02	GnEgyTm	Duration of energy measurement for the generator in hours	✗	✓
332.03	GnOpTmh	Operating hours counter for generator in hours	✗	✓
332.04	GnStrCnt	Number of generator starts	✗	✓

13.2.4 Report (400#)

410# Error Active

Display of currently pending warnings and errors (see Section 10 "Troubleshooting", page 46).

420# Error History

History of warnings and errors (see Section 10 "Troubleshooting", page 46).

430# Event History



History of events (see Section 10 "Troubleshooting", page 46).

440# Error Grid

History of the last five grid errors (see Section 10 "Troubleshooting", page 46).

13.2.5 Operation (500#)

13.2.5.1 Inverter (510#)

No.	Name	Description	Value	Explanation			Default Value
510.01	InvRs	Initiate device restart	No	Do not restart	✓	✓	-
			Yes	Restart			
510.02	InvTmOpEna	Time-controlled inverter operation:	Disable	Disable	✗	✓	Disable
			Enable	Enable			
510.03	InvTmOpStrDt	Start date for time-controlled inverter operation in dd.mm.yyyy	-	-	✗	✓	-
510.04	InvTmOpStrTm	Time for the start of time-controlled operation in hh:mm:ss	00:00:00 to 23:59:59	-	✗	✓	-
510.05	InvTmOpRnDur	Run time for time-controlled inverter operation in hh:mm:ss	00:00:00 to 99:59:00	-	✗	✓	-
510.06	InvTmOpCyc	Repetition cycle for time-controlled inverter operation	Single	Once	✗	✓	Single
			Daily	Daily			
			Weekly	Weekly			







No.	Name	Description	Value	Explanation			Default Value
510.07	CntRs	Delete energy meter The value indicates which energy meter is to be deleted.	Inv	Sunny Island	✓	✓	-
			Bat	Battery			
			Gn	Generator			
			Gd	Utility grid			
			All	All Energy meter			
			Sic1	Sunny Island Charger 1			
			Sic2	Sunny Island Charger 2			
			Sic3	Sunny Island Charger 3			
			Sic4	Sunny Island Charger 4			
			SicAll	All Sunny Island Charger charge controllers			
510.08	TstClstCom	Activation of communication test between individual clusters (expert mode)	Off	Off	✗	✓	-
			Transmit	Enable	*		
510.09	ClstComStt	Status of communication test (expert mode)	Wait	Waiting	✗	✓	-
			OK	Completed	*		

* With firmware version 3.5, this parameter can also be set for systems connected to the utility grid. Firmware version 3.5 of Sunny Island can only be used in multicuster systems with the Multicuster-Box 12 of device type MC-BOX-12.3-20.









13.2.5.2 Battery (520#)

No.	Name	Description	Value	Explanation			Default value
520.01	ChrgSelMan	Manual equalization charge	Idle	Waiting until conditions are met	✓	✓	Idle
			Start	Starting			
			Stop	Stop			





13.2.5.3 Generator (540#)

No.	Name	Description	Value	Explanation	 	Default value
540.01	GnManStr	Manual generator start	Auto	Automatic	 	Auto
			Start	Starting		
			Stop	Stop		
			Run1h	Start for 1 hour		
540.02	GnAck	Acknowledgment of generator errors	Ackn	Acknowledge	 	-

13.2.5.4 MMC Card (550#)

No.	Name	Description	Value	Explanation	 
550.01	ParaSto	Parameter Settings save	Set1	Parameter set 1	 
			Set2	Parameter set 2	
550.02	ParaLod	Load parameter settings (expert mode)	Set1	Parameter set 1	 
			Set2	Parameter set 2	
			Factory	Load default settings	
550.03	CardFunc	Functions of the SD memory card	ForcedWrite	Forced write	 
			StoEvtHis	Storing event memory	
			StoFailHis	Save error log	
			StoHis	Storing event and fault memory	

13.2.5.5 Grid (560#)

No.	Name	Description	Value	Explanation	 	Default value
560.01	GdManStr	Manual connection to the utility grid Visible if the parameter 233.01 GdSocEna or 233.08 GdPwrEna is enabled.	Auto	Automatic	 	Auto
			Start	Starting		
			Stop	Stop		

14 Parameters in the Communication Product

Most parameters of the Sunny Island inverter can be called up and set on the communication product (e.g. Sunny Explorer or Sunny Portal). Links to additional information can be found at www.SMA-Solar.com.

Document title and content	Document type
SUNNY EXPLORER Call up and set the parameters in Sunny Portal	User Manual
SUNNY HOME MANAGER in SUNNY PORTAL Call up and set the parameters in Sunny Portal	User Manual
SUNNY ISLAND - Comparison of the same parameters for Speedwire (e.g. Sunny Explorer) and RS485 (e.g. Sunny Remote Control)	Technical Information

15 Menu Structure

15.1 User Mode

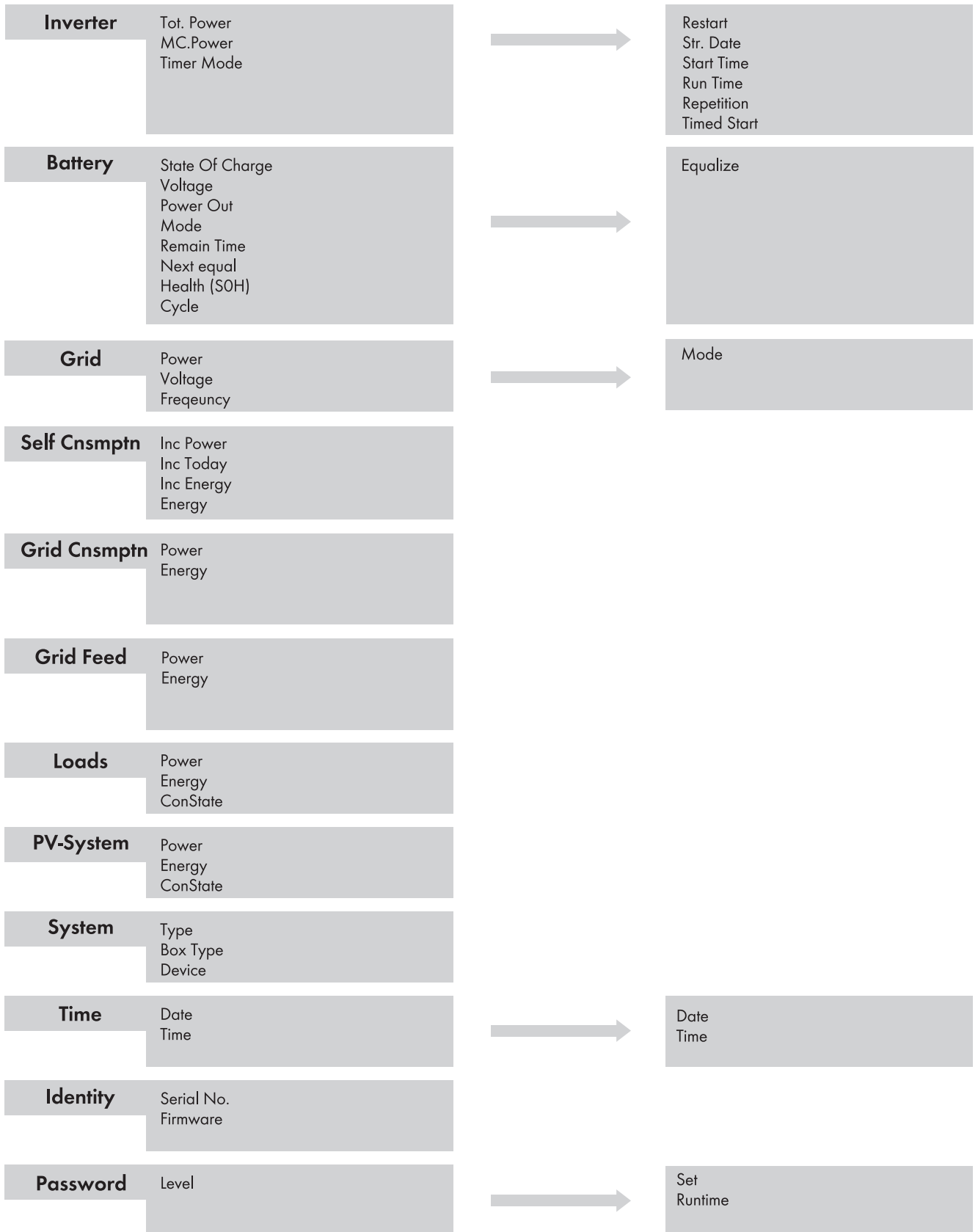

Figure 19: Menu structure: user mode

15.2 Installer Mode and Expert Mode

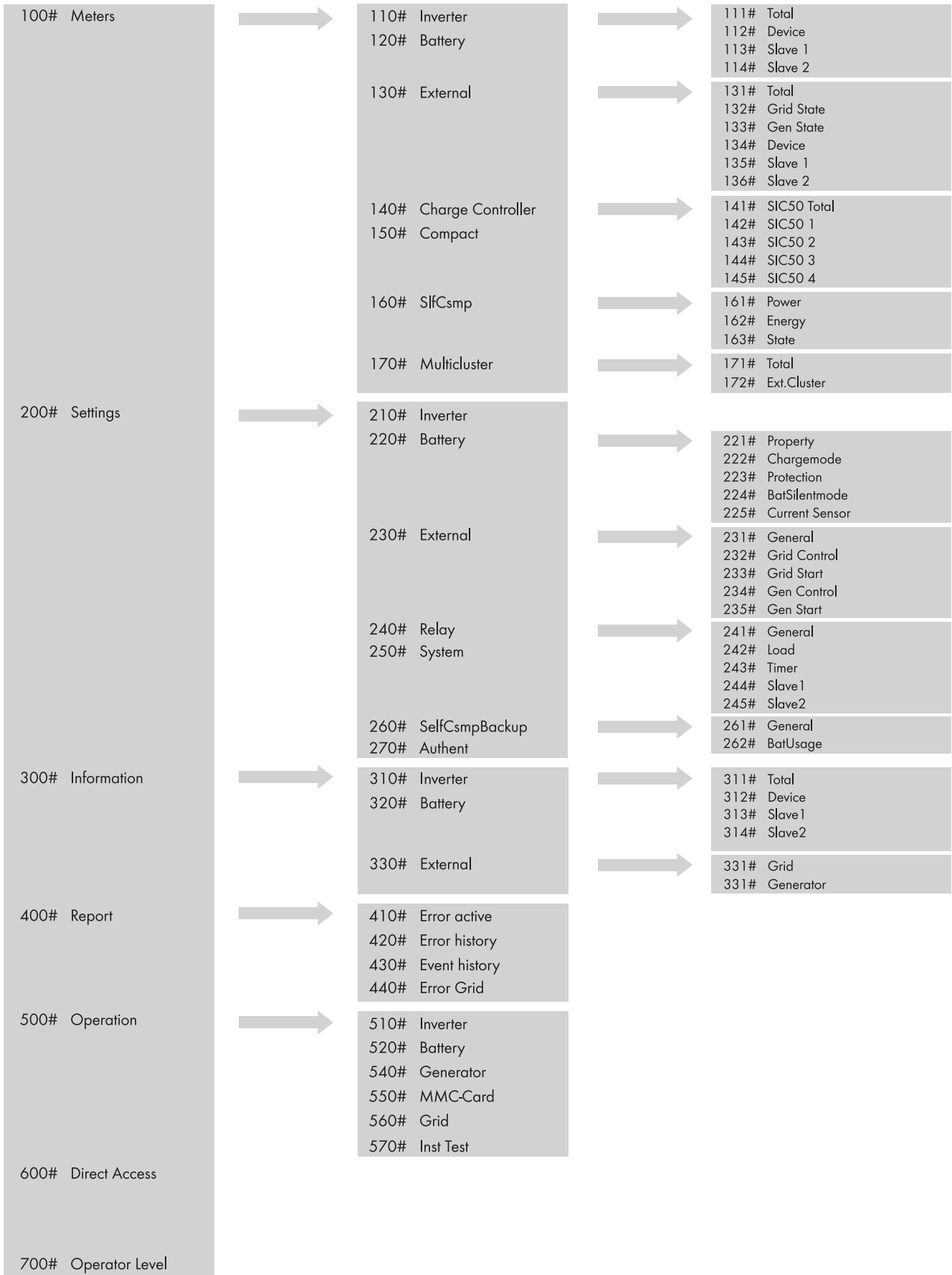

Figure 20: Menu structure: installer mode and expert mode

16 Contact

If you have technical problems with our products, please contact the SMA Service Line. We require the following information in order to provide you with the necessary assistance:

- Sunny Island inverter type
- Sunny Island inverter serial number
- Sunny Island inverter firmware version
- Error message displayed
- Type of battery connected
- Nominal battery capacity
- Nominal battery voltage
- Type of the communication products connected
- Type and size of additional energy sources

In order to receive service assignments for the Sunny Island system, all system data must be recorded in the information sheet for Sunny Island systems during commissioning and made available to Service (for information sheet see www.SMA-Solar.com).

Danmark	SMA Solar Technology AG	Belgien	SMA Benelux BVBA/SPRL
Deutschland	Niestetal	Belgique	Mechelen
Österreich	SMA Online Service Center:	België	+32 15 286 730
Schweiz	www.SMA-Service.com	Luxemburg	
	Sunny Boy, Sunny Mini Central, Sunny Tripower: +49 561 9522-1499	Luxembourg	
	Monitoring Systems (Kommunikation- sprodukte): +49 561 9522-2499	Nederland	
	Fuel Save Controller (PV-Diesel-Hy- bridsysteme): +49 561 9522-3199	Česko	SMA Service Partner TERMS a.s.
	Sunny Island, Sunny Backup, Hydro Boy: +49 561 9522-399	Magyarország	+420 387 6 85 111
	Sunny Central: +49 561 9522-299	Slovensko	
France	SMA France S.A.S.	Polska	SMA Polska
	Lyon		+48 12 283 06 66
	+33 472 22 97 00	Ελλάδα	SMA Hellas AE
España	SMA Ibérica Tecnología Solar, S.L.U.	Κύπρος	Αθήνα
Portugal	Barcelona		+30 210 9856666
	+34 935 63 50 99	United Kingdom	SMA Solar UK Ltd.
Bulgaria	SMA Italia S.r.l.		Milton Keynes
Italia	Milano		+44 1908 304899
România	+39 02 8934-7299		
United Arab Emirates	SMA Middle East LLC	India	SMA Solar India Pvt. Ltd.
	Abu Dhabi		Mumbai
	+971 2234 6177		+91 22 61713888

ไทย	SMA Solar (Thailand) Co., Ltd. กรุงเทพฯ +66 2 670 6999	대한민국	SMA Technology Korea Co., Ltd. 서울 +82-2-520-2666
South Africa	SMA Solar Technology South Africa Pty Ltd. Cape Town 08600SUNNY (08600 78669) International: +27 (0)21 826 0600	Argentina Brasil Chile Perú	SMA South America SPA Santiago +562 2820 2101
Australia	SMA Australia Pty Ltd. Sydney Toll free for Australia: 1800 SMA AUS (1800 762 287) International: +61 2 9491 4200	Other countries	International SMA Service Line Niestetal Toll free worldwide: 00800 SMA SERVICE (+800 762 7378423)

**ENERGY
THAT
CHANGES**

