

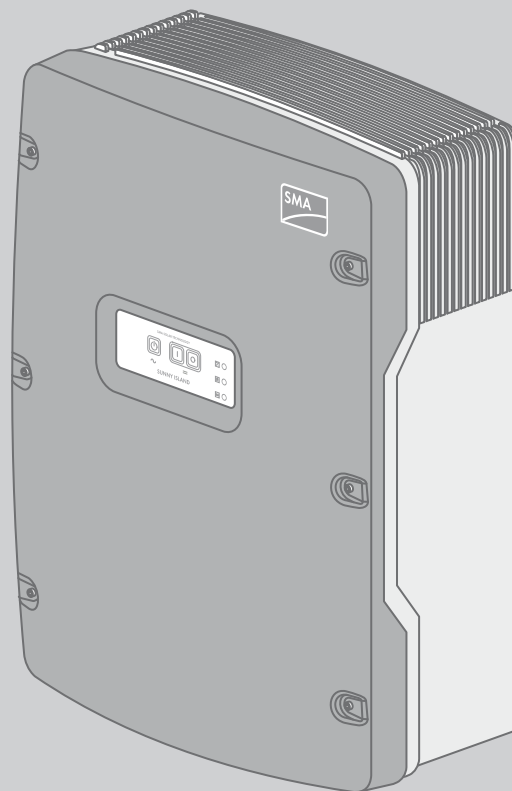

Installation Manual

## **SUNNY ISLAND 6.0H / 8.0H**



## Legal Provisions

The information contained in this document is the property of SMA Solar Technology AG. Publishing its content, either partially or in full, requires the written permission of SMA Solar Technology AG. Any internal company copying of the document for the purposes of evaluating the product or its correct implementation is allowed and does not require permission.

### SMA Warranty

The current warranty conditions come enclosed with your device. These are also available online at [www.SMA-Solar.com](http://www.SMA-Solar.com) and can be downloaded and are available on paper from the usual sales channels if required.

### Trademarks

All trademarks are recognized even if these are not marked separately. Missing designations do not mean that a product or brand is not a registered trademark.

The *Bluetooth*<sup>®</sup> word mark and logos are registered trademarks owned by Bluetooth SIG, Inc. and any use of such marks by SMA Solar Technology AG is under license.

QR Code<sup>®</sup> is a registered trademark of DENSO WAVE INCORPORATED.

### SMA Solar Technology AG

Sonnenallee 1  
34266 Niestetal  
Germany

Tel. +49 561 9522-0  
Fax +49 561 9522-100  
[www.SMA.de](http://www.SMA.de)  
E-mail: [info@SMA.de](mailto:info@SMA.de)

© 2004 to 2014 SMA Solar Technology AG. All rights reserved.

## Table of Contents

<b>1</b>	<b>Information on this Document</b>	<b>7</b>
<b>2</b>	<b>Safety</b>	<b>9</b>
2.1	Intended Use	9
2.2	Skills of Qualified Persons	9
2.3	Safety Precautions	10
<b>3</b>	<b>Scope of Delivery</b>	<b>13</b>
<b>4</b>	<b>Additional Tools Required</b>	<b>15</b>
<b>5</b>	<b>Product Description</b>	<b>16</b>
5.1	Sunny Island	16
5.2	Multifunction Relay	17
5.3	Communication	18
<b>6</b>	<b>Mounting</b>	<b>19</b>
6.1	Safety during Mounting	19
6.2	Requirements for Mounting	19
6.3	Mounting the Sunny Island	21
<b>7</b>	<b>Electrical Connection</b>	<b>24</b>
7.1	Content and Structure of the Section	24
7.2	Connection Area	25
7.3	Connecting the Grounding Conductor in Systems with Grounded Battery	25
7.4	Connecting the Components	27
7.4.1	Connecting the Fuse Switch-Disconnecter BatFuse to the Sunny Island	27
7.4.2	Connecting the Utility Grid in the System for Increased Self-Consumption	28
7.4.3	Connecting an Automatic Transfer Switch in the Battery Backup System	29
7.4.3.1	Automatic Transfer Switch Function	29
7.4.3.2	Connecting the AC Power Cables to the Automatic Transfer Switch	29
7.4.3.3	Connecting the Control Cables to the Automatic Transfer Switch	29
7.4.3.4	Connecting the Measuring Cables to the Automatic Transfer Switch	30
7.4.4	Connecting the Stand-Alone Grid or Multicluster Box	31
7.4.5	Connecting the Generator in an Off-Grid System	32
7.4.6	Inserting Filler-Plugs	32
7.4.7	Communication Connection	33
7.4.7.1	Connecting the Sunny Remote Control	33
7.4.7.2	Connecting the Data Cable of the Lithium-Ion Batteries	33
7.4.7.3	Connecting Speedwire	33
7.4.7.4	Connecting the Data Cable for the Internal Communication of the Cluster	34
7.4.7.5	Connecting the Data Cable of the Sunny Island Charger 50	36
7.4.7.6	Connecting the Data Cable of the Multicluster Box	37
7.4.7.7	Connecting Control and Measuring Cables of the Multicluster Box	37
7.4.7.8	Connecting the Cable of the Multicluster Communication	38
7.4.7.9	Connecting RS485	39
7.4.8	Connecting the Battery Temperature Sensor	40
7.4.9	Connecting the Battery Current Sensor	41
7.4.10	Connecting the Control Cable for Autostart Generators	42

7.4.11	Connecting a Signal Generator for Generators without Autostart Function	43
7.4.12	Connecting Load-Shedding Contactors	44
7.4.13	Connecting the Time Control for External Processes	45
7.4.14	Connecting Message Devices for Operating States and Warning Messages	46
7.4.15	Connecting the Battery Room Fan	47
7.4.16	Connecting the Electrolyte Pump for the Battery	48
7.4.17	Connecting the Control Cable for the Use of Excess Energy in an Off-Grid System	49
7.4.18	Connecting the Signal Cable of the External Generator Request	50
7.5	Connecting the Cables	51
7.5.1	Connecting the DC Power Cable	51
7.5.2	Connecting the AC Power Cable	54
7.5.3	Connecting the Grounding Conductor	55
7.5.4	Connecting the Data Cables	56
7.5.5	Connecting Relay 1 and Relay 2	57
7.5.6	Connecting BatVtg, DigIn, BatTMP and BatCur	58
7.5.7	Connecting ExtVtg	58
7.6	Checking the Wiring	59
7.7	Closing the Sunny Island	62
7.8	Inserting the Fuse Links in the Fuse Switch-Disconnecter BatFuse	62
<b>8</b>	<b>Commissioning</b>	<b>63</b>
8.1	Basic Configuration	63
8.1.1	Starting the Quick Configuration Guide	63
8.1.2	Performing Basic Configuration of the Sunny Island	64
8.1.3	Setting Sunny Island Charger for Charge Controller/Sunny Island Charger in Off-Grid Systems	64
8.1.4	Commissioning the Battery Current Sensor in Off-Grid Systems	65
8.1.5	Setting the Functions of the Multifunction Relays	67
8.2	Battery Management	68
8.2.1	Adjusting the Battery Management to the Battery	68
8.2.2	Changing the Battery Usage through Battery Backup Systems without Increased Self-Consumption	69
8.2.3	Battery Usage through Systems for Increased Self-Consumption	70
8.2.3.1	Seasonal Adjustment of the Battery Usage	70
8.2.3.2	Changing the Battery Usage through Systems for Increased Self-Consumption without a Battery Backup Grid	71
8.2.3.3	Changing the Battery Usage through Battery Backup Systems with Increased Self-Consumption	74
8.2.4	Changing the Battery Protection Mode in Off-Grid Systems	77
8.2.5	Configuring the Resistance of the Battery Cable	78
8.2.6	Setting the Control of the Battery Room Fan	79
8.3	Energy Management	79
8.3.1	Setting Load Shedding in a Multicluster System	79
8.3.2	Setting 1-Level Load Shedding	80
8.3.3	Setting 2-Level Load Shedding	80
8.3.4	Setting Time-Dependent 1-Level Load Shedding	82
8.3.5	Setting Time-Dependent 2-Level Load Shedding	83
8.3.6	Setting Energy Saving Modes in Battery Backup Systems	84
8.3.7	Setting Utilization of Excess Energy in Off-Grid Systems	85
8.4	Generator Management	86
8.4.1	Configuring the Thresholds for the Generator Terminal	86
8.4.1.1	Changing the Current Thresholds for the Generator	86

8.4.1.2	Changing the Voltage Thresholds for the Generator	86
8.4.1.3	Changing the Frequency Thresholds of the Generator Voltage	86
8.4.1.4	Changing the Permitted Reverse Power in the Generator	87
8.4.1.5	Configuring the Current Limit for the Generator Depending on the Frequency	87
8.4.2	Changing the Type of the Generator Interface	87
8.4.3	Configuring Generator Run-Times	88
8.4.3.1	Changing the Warm-Up Time for the Generator	88
8.4.3.2	Changing the Minimum Run Time for the Generator	88
8.4.3.3	Changing the Power-Down Time for the Generator	88
8.4.3.4	Changing the Minimum Stop Time for the Generator	88
8.4.4	Configuring the Generator Request	89
8.4.4.1	Changing the Automatic Generator Operation	89
8.4.4.2	Changing a State-Of-Charge-Dependent Generator Request	89
8.4.4.3	Setting a Time-Dependent Generator Request	89
8.4.4.4	Configuring the Load-Dependent Generator Request	90
8.4.4.5	Time-Controlled Generator Requesting	91
8.4.4.6	Changing the Generator Request via the Charging Process of the Battery	91
8.4.4.7	Setting an External Generator Request	92
8.4.5	Configuring the Procedure in the Event of a Generator False Start	92
8.5	Setting the Time Control	93
8.6	Changing Thresholds for Systems for Increased Self-Consumption	93
8.7	Changing the Automatic Frequency Synchronization in Off-Grid Systems	93
8.8	Completing Commissioning	94
<b>9</b>	<b>Supplementary Information</b>	<b>95</b>
9.1	Entering the SMA Grid Guard Code	95
9.2	Determining the Battery Capacity	95
9.3	Setting Time-Dependent Functions	95
9.4	Setting Time-Controlled Functions	96
<b>10</b>	<b>Technical Data</b>	<b>97</b>
10.1	AC1 Connection for Stand-Alone Grid	97
10.2	AC2 Connection for Utility Grid and Generator	98
10.3	DC Connection for Battery	99
10.4	Efficiency	99
10.5	Sunny Island 6.0H Efficiency Profile	100
10.6	Sunny Island 8.0H Efficiency Profile	100
10.7	Power-Temperature Curve	101
10.8	Power Consumption	101
10.9	Noise Emission	101
10.10	Grid Configuration	101
10.11	Protective Devices	101
10.12	Equipment	102
10.13	DC Load Limitation Curve of the Multifunction Relays	102
10.14	General Data	103
<b>11</b>	<b>Accessories</b>	<b>104</b>
<b>12</b>	<b>Contact</b>	<b>105</b>



# 1 Information on this Document

## Validity

This document is valid for the following device types as of firmware version 3.0:

- SI6.0H-11 (Sunny Island 6.0H)
- SI8.0H-11 (Sunny Island 8.0H)

## Target Group









This document is intended for qualified persons. Only persons with the appropriate skills are allowed to perform the tasks described in this document (see Section 2.2 "Skills of Qualified Persons", page 9).

## Additional Information

Additional information is available at [www.SMA-Solar.com](http://www.SMA-Solar.com):

Document title	Document type
Battery Management in Off-Grid Systems	Technology Brochure 6
Battery Management	Technical Information
Battery Backup Systems	Planning Guidelines
SMA Smart Home	Planning Guidelines

## Symbols

Symbol	Explanation
	Indicates a hazardous situation which, if not avoided, will result in death or serious injury
	Indicates a hazardous situation which, if not avoided, can result in death or serious injury
	Indicates a hazardous situation which, if not avoided, can result in minor or moderate injury
	Indicates a situation which, if not avoided, can result in property damage
	Information that is important for a specific topic or goal, but is not safety-relevant
	Indicates a requirement for meeting a specific goal
	Desired result
	A problem that might occur

## Typographies

Typography	Usage	Example
<b>bold</b>	<ul style="list-style-type: none"> <li>• Display messages</li> <li>• Parameter</li> <li>• Terminals</li> <li>• Fuse holders</li> <li>• Elements to be selected</li> <li>• Elements to be entered</li> </ul>	<ul style="list-style-type: none"> <li>• Connect the grounding conductor to <b>AC 2Gen/Grid</b>.</li> <li>• Select the parameter <b>235.01 GnAutoEna</b> and set to <b>Off</b>.</li> </ul>
<b>&gt;</b>	<ul style="list-style-type: none"> <li>• Several elements that are to be selected</li> </ul>	<ul style="list-style-type: none"> <li>• Select <b>600# Direct Access &gt; Select Number</b>.</li> </ul>

## Nomenclature

Complete designation	Designation in this document
Off-grid system, battery backup system, system for increased self-consumption	System
Sunny Boy, Sunny Mini Central, Sunny Tripower	PV inverter

Menus are depicted as follows: menu number, pound sign and menu name (e.g. 150# Compact Meters).

Parameters are presented as follows: menu number, period, parameter number and parameter name (e.g. 150.01 GdRmgTm). The term parameter includes parameters with configurable values as well as parameters for displaying values.

## Abbreviations

Abbreviation	Designation	Explanation
AC	Alternating Current	-
DC	Direct Current	-
FLA	Flooded Lead Acid Batteries	-
FSPC	Frequency Shift Power Control	-
LED	Light-Emitting Diode	-
MSL	Mean Sea Level	-
PV	Photovoltaics	-
QCG	Quick Configuration Guide	-
SOC	State of Charge	State of charge of the battery
SOH	State of Health	Battery capacity available for consumption
VDE	Verband der Elektrotechnik Elektronik Informationstechnik e. V.	Association for Electrical, Electronic and Information Technologies
VRLA	Valve Regulated Lead-Acid	-



## 2 Safety

### 2.1 Intended Use

The Sunny Island is a battery inverter which controls the electrical energy balance in an off-grid system, in a battery backup system or in a system for increased self-consumption. The Sunny Island can additionally be used for increased self-consumption in a battery backup system.

The Sunny Island is suitable for indoor-use and in weather-protected outdoor areas.

The grid configuration of the generator or the utility grid must be a TN or TT system. Cables with copper wires must be used for the installation.

Only use this product in accordance with the enclosed documentation and with the local standards and directives. Any other application may cause personal injury or property damage.

The Sunny Island is not suitable for supplying life-sustaining medical devices. A power outage must not lead to personal injury.

AC sources (e.g. PV inverters) can be used in off-grid systems and battery backup systems for energy supply. Too much power from the AC sources in the stand-alone grid or with battery backup systems in a battery backup grid can lead to system failures. The maximum output power of the AC sources must be observed in off-grid systems and battery backup systems (see Section 10 "Technical Data", page 97). The powers of the individual Sunny Island inverters are added to yield the total maximum power.

The Sunny Island uses batteries for energy storage. The nominal voltage of the battery must correspond to the input voltage on the DC terminal. A fuse switch-disconnector (e.g. BatFuse) must be installed between the battery and the Sunny Island. The battery room must be ventilated in accordance with the requirements of the battery manufacturer and with the locally applicable standards and directives (see documentation of the battery manufacturer). If lithium-ion batteries are connected, the battery management of the lithium-ion battery must be compatible with the Sunny Island (see the Planning Guidelines "SMA Smart Home" at [www.SMA-Solar.com](http://www.SMA-Solar.com)).

DC loads and charge controllers can only be included in off-grid systems. If DC loads and charge controllers are included, a battery current sensor must be installed. This requirement does not apply to Sunny Island Charger devices. Up to four Sunny Island Charger devices can be installed in the system without a battery current sensor. The Sunny Island is not suitable for establishing a DC distribution grid.

The Sunny Island can control various components in the system (e.g. load shedding contactors) via two multifunction relays. The multifunction relays are not suitable for controlling functions which may endanger persons in the event of a malfunction in the multifunction relays – for example, if there is insufficient redundancy in the ventilation of the battery room.

Changes to the product, e.g. modifications or retrofitting, are only allowed when permitted explicitly by SMA Solar Technology AG in writing. Making unauthorized changes will void the warranty and warranty claims and will normally result in invalidation of the operating permit. SMA Solar Technology AG shall not be held liable for damages caused by such changes.

Any use of the product other than that described in the Intended Use section does not qualify as appropriate.

The enclosed documentation is an integral part of this product. Keep the documentation in a convenient place for future reference and observe the instructions.

The type label must remain permanently attached to the product.

### 2.2 Skills of Qualified Persons

Qualified persons must have the following skills:

- Training in how to deal with the dangers and risks associated with installing and using electrical devices and batteries
- Training in the installation and commissioning of electrical devices
- Knowledge of and adherence to the local standards and directives
- Knowledge of and adherence to this document and all safety precautions

## 2.3 Safety Precautions

This section contains safety precautions that must be observed at all times when working on or with the product. To prevent personal injury or property damage and to ensure long-term operation of the product, read this section carefully and follow all safety precautions at all times.

### **⚠ WARNING**

#### **Danger to life from electric shock due to live voltage**

High voltages are present inside the Sunny Island. When the enclosure lid is removed, live components can be touched which can result in death or serious injury due to electric shock.

- When carrying out any work on the electrical installation, wear suitable personal protective equipment.
- Turn off or disconnect the following components from voltage sources in the given order:
  - Sunny Island
  - In the distribution board the circuit breakers of the Sunny Island and of the control and measuring voltages
  - Load-break switch of the battery
- Ensure that the system cannot be reconnected.
- Open the enclosure lid of the Sunny Island and ensure that no voltage is present.
- Ground and short-circuit the AC conductors outside the Sunny Island.
- Cover or shield any adjacent live components.

#### **Danger to life from electric shock due to damaged Sunny Island**

Operating a damaged Sunny Island can lead to hazardous situations that result in death or serious injuries due to electric shock.

- Only use the Sunny Island when it is technically faultless and in an operationally safe state.
- Check the Sunny Island for visible damage.
- Make sure that all external safety equipment is freely accessible at all times.
- Make sure that all safety equipment is in good working order.

#### **Danger to life due to explosive gases**

Explosive gases may escape from the battery and cause an explosion. This can result in death or serious injury.

- Protect the battery environment from open flames, embers or sparks.
- Install, operate and maintain the battery according to the manufacturer's specifications.
- Do not heat or burn the battery above the temperature permitted.
- Ensure that the battery room is sufficiently ventilated.

**⚠ WARNING****Chemical burns and poisoning due to battery electrolyte**

If handled inappropriately, electrolyte from the battery can burn the eyes, respiratory system and skin, and emit toxic fumes. This may result in blindness and serious chemical burns.

- Protect the battery enclosure against destruction.
- Do not open or deform the battery.
- Whenever working on the battery, wear suitable personal protective equipment such as rubber gloves, apron, rubber boots and goggles.
- Rinse acid splashes thoroughly with clear water for a long time and consult a doctor.
- Install, operate, maintain and dispose of the battery according to the manufacturer's specifications.

**Risk of injury due to short-circuit currents**

Short-circuit currents in the battery can cause heat build-up and electric arcs. Burns or eye injury due to flashes may result.

- Remove watches, rings and other metal objects.
- Use insulated tools.
- Do not place tools or metal parts on the battery.

**Risk of crushing injuries due to movable generator parts**

Moving parts in the generator can crush or sever body parts. A generator can be started automatically by the Sunny Island.

- Only operate the generator with the safety equipment.
- Install, maintain, and operate the generator according to the manufacturer standards.

**⚠ CAUTION****Risk of burns due to short-circuit currents on the disconnected Sunny Island**

The capacitors at the DC terminal input area store energy. When isolating the battery from the Sunny Island, there is still battery voltage present on the DC terminal temporarily. A short circuit on the DC terminal can lead to burns and may damage the Sunny Island.

- Wait ten minutes before working on the DC terminal or on the DC cables. This allows the capacitors to discharge.

**Risk of burns due to hot components**

Some components of the Sunny Island can become very hot during operation. Touching these components can result in burn injuries.

- Only touch the enclosure lid of the Sunny Island during operation.
- When the Sunny Island is open, do not touch hot surfaces.

**NOTICE****Damage to the battery due to incorrect settings**

Incorrect settings lead to premature aging of the battery. Settings of the parameters in the menu **220# Battery** influence the charging behavior of the Sunny Island.

- Ensure that the values recommended by the battery manufacturer are set for the battery (refer to the technical data of the battery in the manufacturer documentation).

**Destruction of the Sunny Island due to electrostatic discharge (ESD)**

By touching electronic components within the Sunny Island, you can damage or destroy the Sunny Island.

- Do not touch electronic assemblies.
- Ground yourself before touching any terminals.

### 3 Scope of Delivery

Check the scope of delivery for completeness and any externally visible damage. Contact your distributor if the scope of delivery is incomplete or damaged.

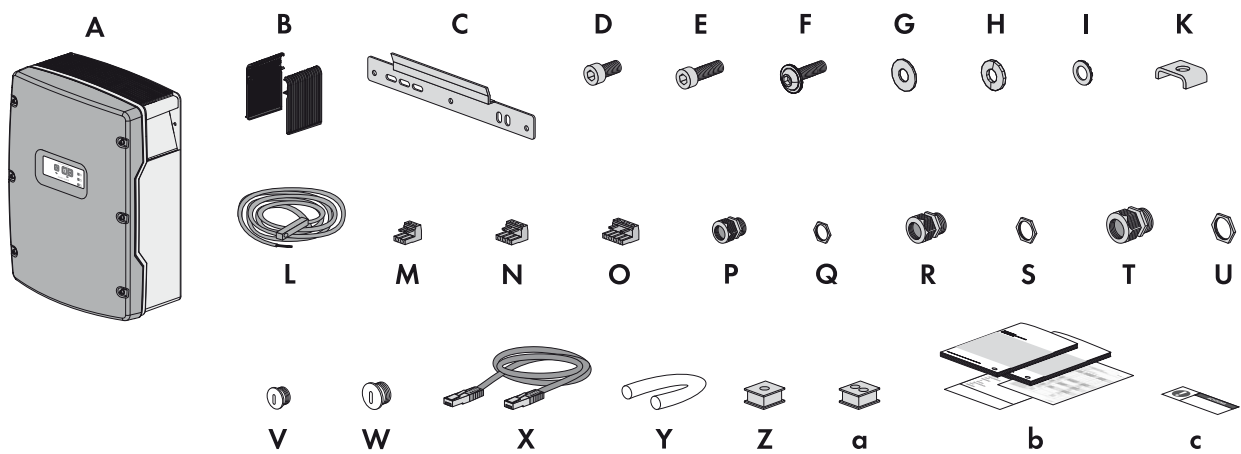

Figure 1: Components included in the scope of delivery

Position	Number	Designation	Position	Number	Designation
A	1	Sunny Island	S	2	Counter nut for M25 cable gland
B	2	Ventilation grid	T	2	M32 cable gland
C	1	Wall mounting bracket	U	2	Counter nut for M32 cable gland
D	2	Hexagon-socket screw M6x10	V	1	Filler plug M20
E	2	Hexagon-socket screw M6x16*	W	1	Filler plug M25
F	2	Hexagon-socket screw M8x20	X	1	Black data cable CAT5e, 2 m
G	2	Fender washer M8	Y	2	Silicon tube 10 mm x 500 mm
H	2	Spring washer M8	Z	1	Cable support sleeve for 1 cable
I	2	M6 conical spring washer*	a	2	Cable support sleeve for 2 cables
K	1	Clamping bracket	b	1	Installation manual, operating manual, document set with declarations and certificates, three Quick Reference Guides: "SMA Flexible Storage System", "Battery Backup Systems", "Off-Grid Systems"
L	1	Battery temperature sensor	c	1	Warning label
M	1	2-pin terminal			
N	2	3-pin terminal			
O	2	4-pin terminal			
P	1	M20 cable gland			
Q	1	Counter nut for M20 cable gland			
R	2	M25 cable gland			

\* 1 spare part for the enclosure lid included

### Communication for RS485 Order Option

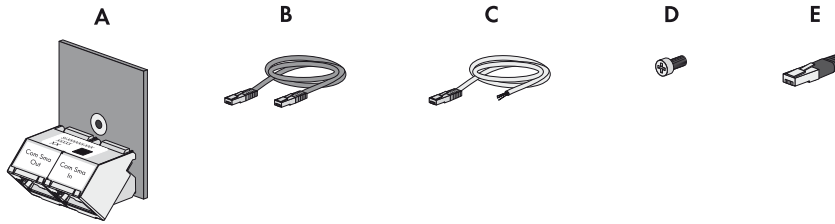

Figure 2: Components of the Communication for RS485 order option

Position	Number	Designation
A	1	SI-COM SMA.BGx, installed in the Sunny Island* ex works
B	1	Gray data cable CAT5e, 5 m
C	1	White data cable CAT5e with three wires with stripped insulation
D	1	Screw, installed in the Sunny Island ex works
E	1	Terminator, plugged into SI-COM SMA.BGx ex works

\* In the case of a cluster system, the communication interface is only installed in the master.

### Communication for Multicluster System Order Option

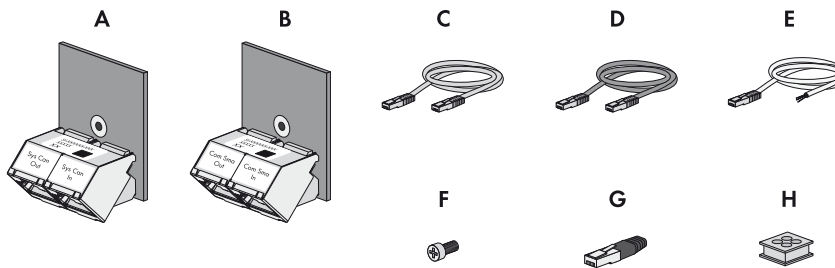

Figure 3: Components of the Communication for multicluster system order option

Position	Number	Designation
A	1	SI-SYSCAN.BGx* , installed in the master ex works
B	1	SI-COM SMA.BGx** , installed in the master ex works
C	1	Yellow data cable CAT5e, 5 m
D	1	Gray data cable CAT5e, 5 m
E	1	White data cable CAT5e with three wires with stripped insulation
F	2	Screw, installed in the Sunny Island ex works
G	2	Terminator, plugged into SI-SYSCAN.BGx and SI-COM SMA.BGx ex works
H	1	Cable support sleeve for 4 cables

\* CAN communication interface

\*\* RS485 communication interface

## 4 Additional Tools Required

Tool	Explanation
Drill	-
Masonry drill	Mounting the wall mounting bracket
Allen key (AF 5)	-
Torque wrench	Attachment: SW5 Measurement range: 4 Nm to 12 Nm
Crimping pliers	Crimping of the DC cable terminal lugs
Crimping tool	Crimping of the bootlace ferrules
Flat-blade screwdriver	Connection of the control and measuring cables to the terminals
Current clamp	Measuring of the battery current
Measuring device for voltage measurement	Measuring of the AC voltages in the system and measuring of the battery voltage

## 5 Product Description

### 5.1 Sunny Island

The Sunny Island is a battery inverter which controls the electrical energy balance in an off-grid system, in a battery backup system or in a system for increased self-consumption. The Sunny Island can additionally be used for increased self-consumption in a battery backup system.

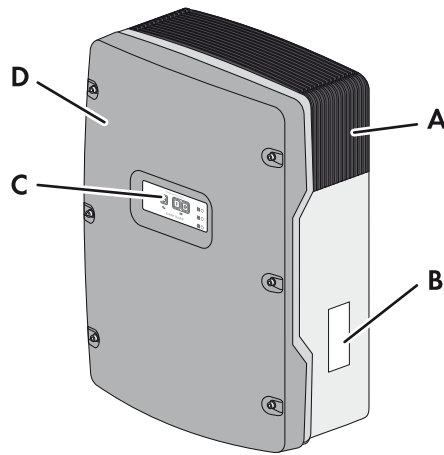

Figure 4: Design of the Sunny Island

Position	Designation
A	Ventilation grid
B	Type label
C	Control panel
D	Enclosure lid

The Sunny Island supplies AC loads in the system from a battery or charges the battery with the energy provided by AC sources (e.g. PV inverter). AC sources supply loads and are used by the Sunny Island to recharge the battery. In order to be able to increase the availability of the off-grid system and reduce the battery capacity, the Sunny Island can use and control a generator as an energy reserve.

The loads may temporarily overload the Sunny Island. If there is a short circuit, the Sunny Island briefly feeds short-circuit currents into the utility grid. As a result, the Sunny Island may trip certain circuit breakers (see Section 10 "Technical Data", page 97).

#### Type Label

The type label clearly identifies the product. The type label is located on the right-hand side of the enclosure (for description of the type label see Sunny Island operating manual).

You will require the information on the type label to use the product safely and when seeking customer support from the SMA Service Line.



## 5.2 Multifunction Relay

Each Sunny Island can control various functions by means of two multifunction relays and display operating states and warning messages. The multifunction relays of the master are permanently adjusted to control the contactors within the automatic transfer switch in battery backup systems.

Possible function or output	Explanation
Controlling generators	The multifunction relay is activated in the event of a generator request from the Sunny Island generator management. With the multifunction relay you can control generators equipped with electrical remote-start function or connect a signal generator for generators with no autostart function (see Section 7.4.10 and 7.4.11).
Control of the tie switch and of the contactors for grounding	In battery backup systems the multifunction relays control the contactors for grid coupling and grounding.
Control of load-shedding contactors	The multifunction relay is activated depending on the state of charge of the battery. Depending on the configuration, you can install a one-level load shedding with one multifunction relay or a two-level load shedding with two multifunction relays. You can also adjust the thresholds for the state of charge of the battery depending on the time of day (see Section 7.4.12).
Time control for external processes	The multifunction relays can be time-controlled (see Section 7.4.13).
Display of operating states and warning messages	Every multifunction relay can display either one event or one warning message (see Section 7.4.14).
Control of a battery room fan	The multifunction relay is activated when the charging current leads to the emission of gases from the battery. A connected battery room fan is being switched on for one hour at least (see Section 7.4.15).
Control of an electrolyte pump	Depending on the nominal energy throughput, the multifunction relay is activated at least once a day (see Section 7.4.16).
Use of excess energy	In off-grid systems during the constant voltage phase, a multifunction relay is activated and thus controls additional loads that can put any excess energy to good use (see Section 7.4.17).

## 5.3 Communication

The Sunny Island is equipped with two interface slots for the connection of SMA communication interfaces.

### Interface Slot SICOMSMA

The interface slot **SICOMSMA** is for connecting the Speedwire data module SWDMSI-xx or the communication interface SI-COMSMA.BGx.

The Speedwire data module SWDMSI-xx allows the inclusion of the Sunny Island in a Speedwire network. Speedwire is a cable-based type of communication based on the Ethernet standard and the communication protocol SMA Data2+. This enables inverter-optimized 10/100 Mbit data transmission between Speedwire devices, e.g. between Sunny Island and Sunny Home Manager.

The communication interface SI-COMSMA.BGx allows the inclusion of the Sunny Island in a RS485 communication bus. You can connect the Sunny Island to the following products using RS485:

- SMA communication products (e.g. Sunny WebBox)
- PV inverters
- Wind power inverter
- Extension cluster masters

When the Sunny Island is ordered with the communication interface SI-COMSMA.BGx, the Sunny Island is going to be delivered with mounted communication interfaces. The SWDMSI-xx data module always has to be retrofitted.

### Interface Slot SISYSCAN

The interface slot **SISYSCAN** is for connecting the Multicluster data module SI-SYSCAN.BGx.

In a multicluster system, the masters of the clusters must communicate with each other via an individual CAN bus. An SI-SYSCAN.BGx communication interface must be installed in each master for multicluster communication.

When the Sunny Island is ordered with the communication interface SI-SYSCAN.BGx, the Sunny Island is going to be delivered with mounted communication interfaces.

## 6 Mounting

### 6.1 Safety during Mounting

This section contains safety precautions that must be observed at all times when working on or with the product. To prevent personal injury or property damage and to ensure long-term operation of the product, read this section carefully and follow all safety precautions at all times.

#### **⚠ WARNING**

##### **Danger to life due to fire or explosion**

Despite careful construction, electrical devices can cause fire. Contact with flammable materials allows the fire to spread. This can result in death or serious injury.

- Do not mount the Sunny Island on flammable construction materials.
- Do not mount the Sunny Island near highly flammable materials.
- Do not mount the Sunny Island in potentially explosive atmospheres.
- Ensure that the battery room is sufficiently ventilated and that all other requirements for the installation location of the battery are complied with (see battery manufacturer documentation). This will prevent the build-up of explosive and dangerous gases.

### 6.2 Requirements for Mounting

#### **Mounting location:**

- The mounting must be on a stable support surface, e.g. concrete, walls. In the living area, ensure that the support surface is not made of drywall or similar. When in operation, the Sunny Island makes noises which can be perceived as annoying.
- The mounting location must be suitable for the weight and dimensions of the Sunny Island (see Section 10 "Technical Data", page 97).
- The mounting location must be clear and safely accessible at all times without the need for any auxiliary equipment (e.g. scaffolding or lifting platforms). Non-fulfillment of these criteria may restrict servicing.
- The mounting location must not hinder access to disconnection devices.
- The mounting location must not be exposed to direct solar irradiation. Direct solar irradiation can cause the Sunny Island to overheat.
- Climatic conditions must be met (see Section 10 "Technical Data", page 97).
- The mounting location must be below 3,000 m above MSL. For altitudes of 2,000 m above MSL, the power is reduced by 0.5% per every 100 m.
- The ambient temperature should be below 40°C. This will ensure optimum operation of the Sunny Island (see Section 10.7 "Power-Temperature Curve", page 101).

**Mounting position:**

Figure 5: Permitted and prohibited mounting positions

- The mounting location must be suitable for a permitted mounting position. The control panel should be at eye level. This will make it easier to operate the buttons and view the LED signals.

**Clearances:**

Figure 6: Minimum clearances

- The mounting location must be suitable for mounting while observing minimum clearances to walls, other Sunny Island units or objects. This will allow for sufficient heat dissipation.

**i Multiple Sunny Island inverters installed in areas with high ambient temperatures**

There must be sufficient clearance between the Sunny Island inverters to ensure that the cooling air of the adjacent inverter is not drawn in.

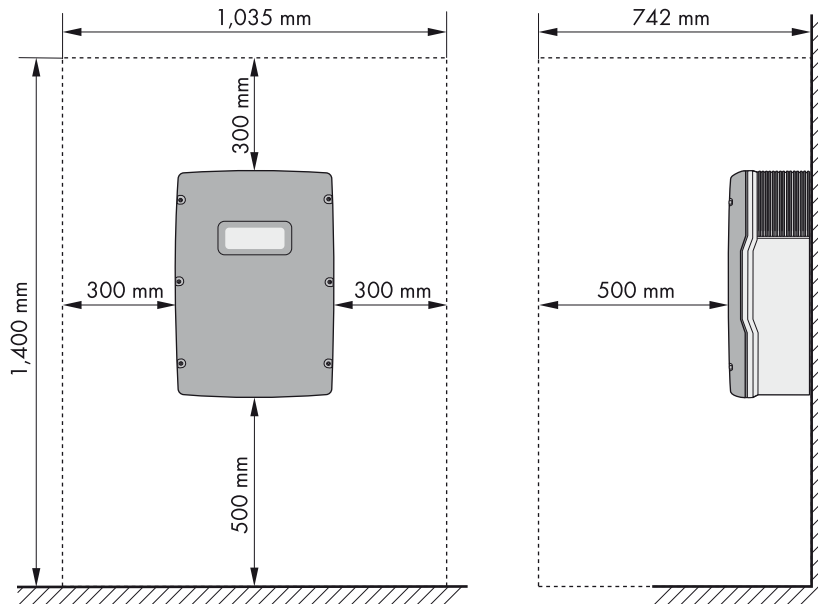
- In order to guarantee sufficient cooling of the Sunny Island inverters, the clearances between the Sunny Island units should be significantly greater than the minimum clearances.
- Provide sufficient fresh-air supply.

## 6.3 Mounting the Sunny Island

Dimensions for wall mounting:

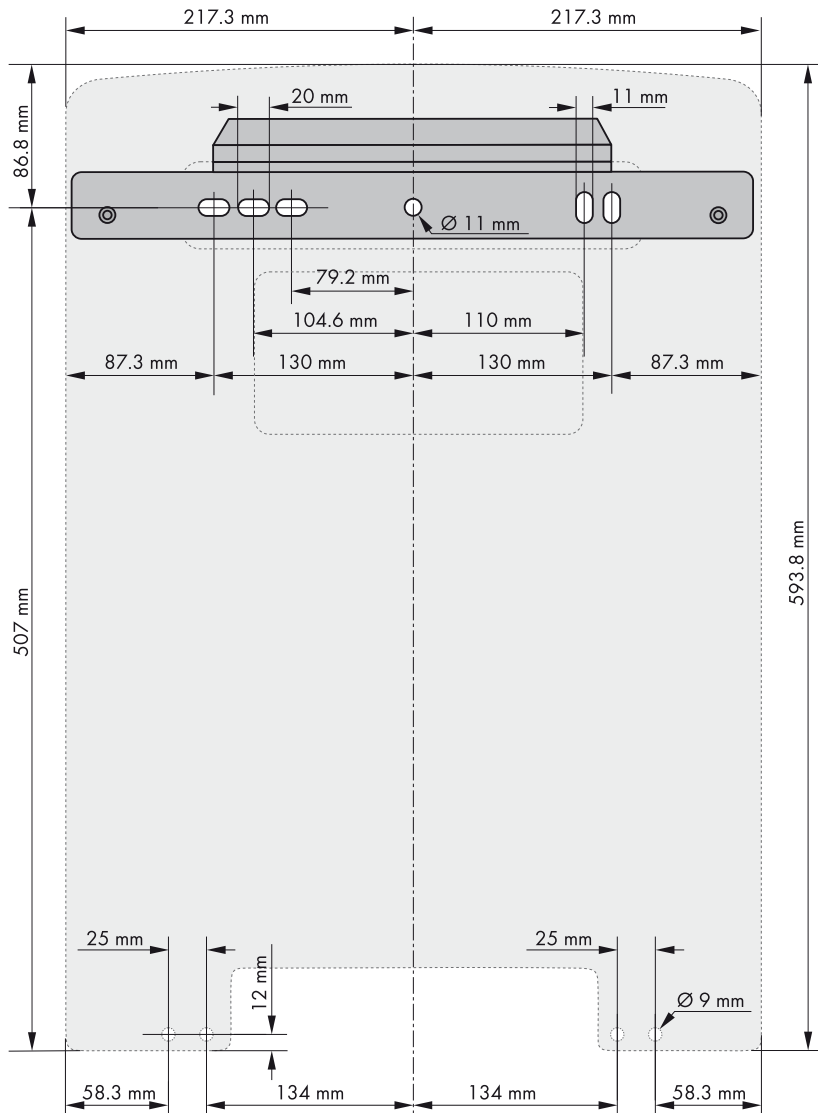

Figure 7: Dimensions of the wall mounting bracket and dimensions of the drill holes in the Sunny Island enclosure for the optional anti-theft device

### **i** Sunny Island with order options "Communication for RS485" or "Multicluster System"

Any ordered communication interfaces are installed in the master ex works. The master can be identified by the labeling on the packaging.

- For single-cluster systems and multicluster systems, mount the Sunny Island units with integrated communication interfaces at the planned mounting locations for masters.

#### **Additionally required mounting material (not included in the scope of delivery):**

- At least two screws that are suitable for the support surface.
- At least two washers that are suitable for the screws.
- At least two screw anchors suitable for the support surface and the screws.
- If the inverter is to be secured against theft, two safety screws that can only be unscrewed with a special tool.

**Procedure:**

1. At the mounting location mark the position of the drill holes using the wall mounting bracket. Use at least one hole on the right-hand and left-hand side in the wall mounting bracket.
2. Ensure that there are no electric lines or other supply lines in the wall behind the marked positions.
3. Drill the holes and insert the screw anchors.
4. Secure the wall mounting bracket horizontally to the wall using screws and washers.
5. If the Sunny Island is to be secured against theft, mark the drill holes for the anti-theft device. Use at least one hole on both the left- and right-hand sides.

6. **CAUTION****Risk of injury due to the heavy weight of the Sunny Island**

Improper transport and mounting can result in the Sunny Island falling. Falling may lead to bruising and broken bones.

- Take the weight of the Sunny Island into account (see Section 10 "Technical Data", page 97).
- Attach the Sunny Island to the wall mounting bracket. To do this, use the side recess grips or a steel rod (diameter: maximum 30 mm). Keep the Sunny Island in a horizontal position during transport.

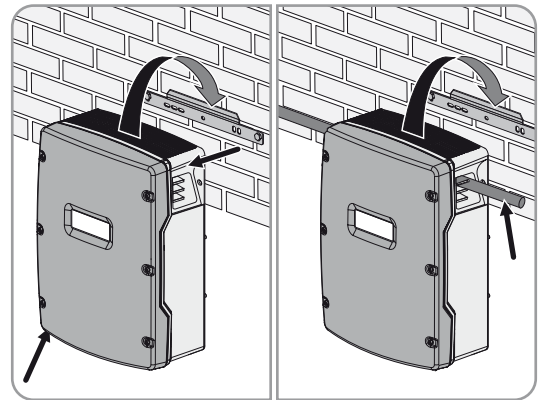

7. Use an Allen key (AF 5) to attach the Sunny Island to the wall mounting bracket on both sides with the M6x10 screws provided (torque: 4 Nm to 5.7 Nm). This will secure the Sunny Island from being lifted off the bracket.

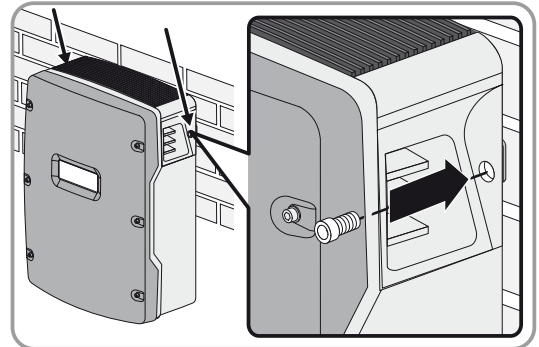

8. Close the recessed grips with the ventilation grids:
  - Plug the ventilation grid marked **links/left** into the left recessed grip.
  - Plug the ventilation grid marked **rechts/right** into the right recessed grip.

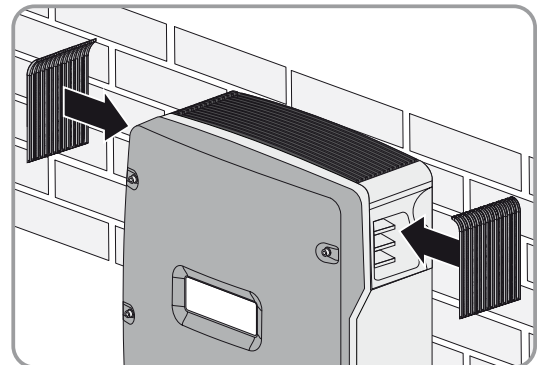

9. In order to protect the Sunny Island against theft, attach the bottom side to the wall with two safety screws.

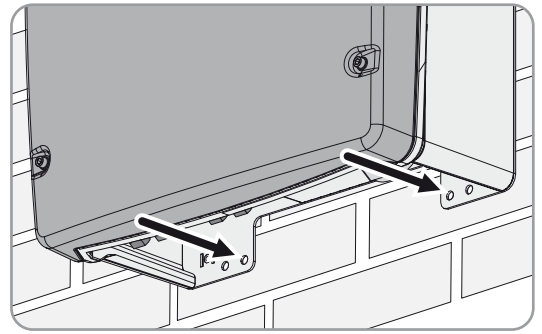

10. Ensure that the Sunny Island is firmly attached.

## 7 Electrical Connection

### 7.1 Content and Structure of the Section

The sub-sections differ in their structure. Some sub-sections refer to the correct connection of components, others refer to basic procedures.

An overview detailing which contents the sub-sections describe and which contents should be read and adhered to can be found in the following table.

Section	Explanation
7.2 Connection Area	Graphic overview of the connection area
7.3 Connecting the Grounding Conductor in Systems with Grounded Battery	For systems with grounded battery, this section must be read and observed.
7.4 Connecting the Components	Information on connection and circuitry of individual components with terminal specification on the Sunny Island
7.5 Connecting the Cables	Correct connection of the cables to the respective terminals You must read and observe the sections for the connections used.
7.6 Checking the Wiring	You must read and observe the section for the connections used.
7.7 Closing the Sunny Island	You must read and observe this section.
7.8 Inserting the Fuse Links in the Fuse Switch-Disconnecter BatFuse	You must read and observe this section.



## 7.2 Connection Area

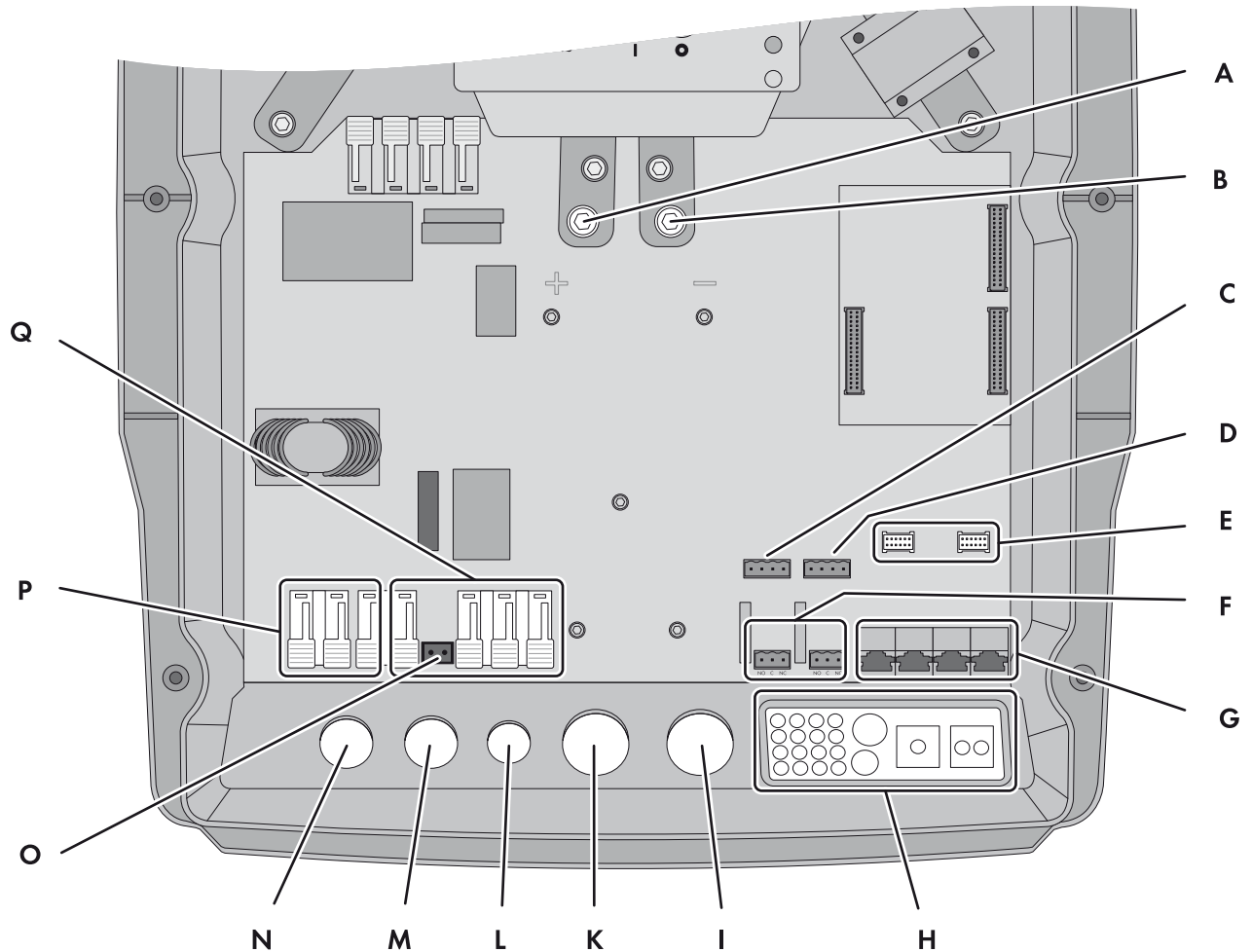

Figure 8: Connection area of the Sunny Island

Position	Designation	Position	Designation
A	DC+ terminal	I	Enclosure opening for DC -
B	DC- terminal	K	Enclosure opening for DC+
C	BatTmp and BatCur terminals	L	Enclosure opening for PE/ExtVtg
D	BatVtg and DigIn terminals	M	Enclosure opening for AC2
E	2 interface slots	N	Enclosure opening for AC1
F	Relay1 and Relay2 terminals	O	ExtVtg terminal
G	Communication terminal	P	AC1 terminal
H	Cable feed-through plate	Q	AC2 terminal

## 7.3 Connecting the Grounding Conductor in Systems with Grounded Battery

If you ground the battery, you can ground the battery at the positive terminal or at the negative terminal with a grounding conductor. SMA Solar Technology AG does not recommend grounding the battery. If the battery is grounded, the enclosure of the Sunny Island must be grounded in addition. This additional grounding is not a substitute for the grounding at terminals **AC1** and **AC2**.

**Conductor cross-section:**

You must determine the required conductor cross-section of the grounding conductor, taking into account the applicable local standards and directives. The calculation of the grounding conductor cross-section depends on the type and size of the connected battery, the external fuse in the BatFuse, and the material of the grounding conductor.

**Example: Calculation of the grounding conductor cross-section**

Grounding conductor made of copper. The required cross-section of the grounding conductor can be calculated using the following formula:

$$S_{Cu} (I, t) = \sqrt{\frac{I_{SC} \cdot t}{143}}$$

$S_{Cu}$  = conductor cross-section in mm<sup>2</sup>

$I_{SC}$  = short-circuit current in A

$t$  = interruption time in s

Typical tripping times for an LV/HRC fuse are around 25 ms for short-circuit currents between 2,000 A and 10,000 A. Grounding with a cross-section of 16 mm<sup>2</sup> is sufficient for short-circuit currents up to 10,000 A.

**Cable requirement:**

- Copper wire
- Maximum conductor cross-section: maximum 16 mm<sup>2</sup>
- The cross-sections of the grounding conductor for the battery and the protective conductor for the Sunny Island must be identical.

**Procedure:**

1. Calculate the cross-section of the grounding conductor.
2. Ground the battery at the positive pole or negative pole using a conductor with the calculated cross-section.
3. Carry out additional grounding of the Sunny Island enclosure using a conductor with the calculated cross-section, as follows:
  - Strip the grounding conductor.
  - Place the clamping bracket over the conductor. Position the conductor on the left.
  - Fasten the clamping bracket using a M6x16 hexagon socket screw and a conical spring washer (AW 5, torque: 4 Nm to 5.7 Nm). The teeth of the conical spring washer must face the clamping bracket.

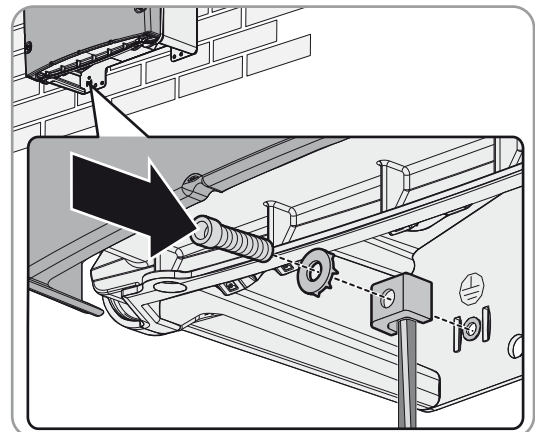
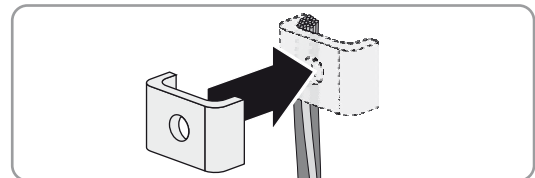

## 7.4 Connecting the Components

### 7.4.1 Connecting the Fuse Switch-Disconnecter BatFuse to the Sunny Island

#### **i** Recommended minimum battery capacity

If the battery capacity selected is too low for off-grid systems and battery backup systems, system failures may result.

- Observe the recommendations for the minimum battery capacity connected to the DC terminal of the Sunny Island (see Section 10 "Technical Data", page 97). The recommended capacities of the individual Sunny Island in a cluster are added to yield the total minimum battery capacity.

#### **i** Cable length and recommended conductor cross-section for the DC connection

Long cables and insufficient conductor cross-sections reduce the efficiency of the system and the overload capacity of the Sunny Island. The maximum cable length from the battery to the Sunny Island is 10 m. The recommended minimum conductor cross-section depends on the battery voltage, the power and the length of the cable:

Sunny Island	Cable length	Conductor cross-section
SI 8.0H	$\leq 5$ m	70 mm <sup>2</sup>
	$> 5$ m	95 mm <sup>2</sup>
SI 6.0H	$\leq 5$ m	50 mm <sup>2</sup>
	$> 5$ m	70 mm <sup>2</sup>

#### **⚠ WARNING**

##### Danger to life due to incompatible lithium ion-battery

An incompatible lithium-ion battery can lead to a fire or an explosion. With incompatible lithium-ion batteries, it is not ensured that the battery management will protect the battery.

- Ensure that the battery is from one of the following manufacturers and has been approved for Sunny Island by the manufacturer:
  - Akasol
  - Dispatch Energy
  - LG Chem
  - Leclanché
  - SAFT
  - Samsung
  - Sony

This list is updated regularly (see Planning Guidelines "SMA Smart Home" at [www.SMA-Solar.com](http://www.SMA-Solar.com)).

#### Procedure:

1. Ensure that the load-break switch of the BatFuse is open and secured against reconnection.
2. On the Sunny Island remove all screws of the lower enclosure lid using an Allen key (AF 5) and remove the enclosure lid. Retain the screws and conical spring washers for later use.
3. Clean the contact surfaces of the **DC+** and **DC-** terminals e.g. with ethanol. This reduces the transition resistance on the contact surfaces. A low transition resistance increases the system stability and minimizes the risk of damage to the Sunny Island.

4. **NOTICE****Damage to the Sunny Island due to reverse polarity or wrong choice of terminal lug**

If the DC cables get swapped, high currents will flow after the load-break switch has closed that can damage the Sunny Island.

- Fasten the DC power cables to the DC terminal with M8x20 screws, ensuring correct polarity (torque: 12 Nm). Make sure that the cable is correctly connected (see Section 7.5.1 "Connecting the DC Power Cable", page 51) and adhere to the following screw assembly: screw head | spring washer | fender washer | terminal lug | DC terminal.

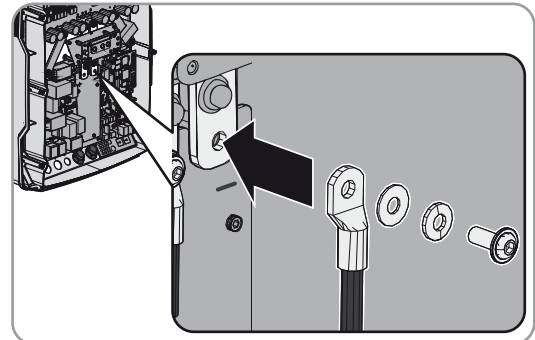

- ☑ The contact surfaces of the fender washers have full contact with the terminal lugs.

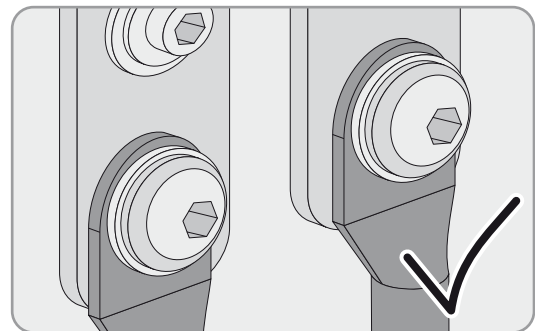
**7.4.2 Connecting the Utility Grid in the System for Increased Self-Consumption****Requirements:**

- ☐ The system is not a battery backup system
- ☐ For connection of the Sunny Island there must be a circuit breaker and a residual-current device installed in the distribution board (for wiring principle, see Quick Reference Guide "SMA Flexible Storage System").

**Procedure:**

1. On the Sunny Island connect the power cable to the terminals **AC2 Gen/Grid**: Ensure that the cable is correctly connected (see Section 7.5.2 "Connecting the AC Power Cable", page 54).
  - Connect the line conductor to **AC2 Gen/Grid**.
  - Connect the neutral conductor to **AC2 Gen/Grid N<sub>TT</sub>**.
  - Connect the grounding conductor to **AC2 Gen/Grid PE**.
2. Connect an additional grounding conductor to the **AC1 Loads/SunnyBoys PE** terminal if the power cable conductor cross-section is smaller than 10 mm<sup>2</sup> (see Section 7.5.3 "Connecting the Grounding Conductor", page 55).

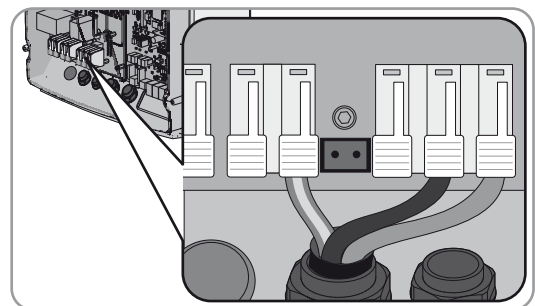

## 7.4.3 Connecting an Automatic Transfer Switch in the Battery Backup System

### 7.4.3.1 Automatic Transfer Switch Function

The automatic transfer switch separates the utility grid from the battery backup grid in battery backup systems. The control cables, measuring cables and power cables connect the automatic transfer switch to the Sunny Island (Circuitry overview see Quick Reference Guide Battery Backup System).

### 7.4.3.2 Connecting the AC Power Cables to the Automatic Transfer Switch

The AC power cables conduct the energy between the battery backup grid and the Sunny Island (for circuitry overview see Quick Reference Guide "Battery Backup System").

#### Requirements:

- For a three-phase battery backup system, L1 must be assigned to the master, L2 to slave 1 and L3 to slave 2. This creates a right-hand rotating magnetic field.
- The power of the AC sources in the battery backup grid must be less than the maximum connectable power of the AC sources (see Section 10.2 "AC2 Connection for Utility Grid and Generator", page 98). The powers of the individual Sunny Island inverters are added to yield the total maximum power.

#### Cable requirements:

- Copper wire
- Number of conductors in the cable: 3
- Conductor cross-section: 10 mm<sup>2</sup> to 16 mm<sup>2</sup>
- Cable diameter: 9 mm to 18 mm

#### Procedure:

- On the Sunny Island connect the power cable of **X3** to the **AC2 Gen/Grid** terminals (for circuitry overview see Quick Reference Guide "Battery Backup System"). Ensure that the cable is correctly connected (see Section 7.5.2 "Connecting the AC Power Cable", page 54).
  - Connect the line conductor to **AC2 Gen/Grid L**.
  - Connect the neutral conductor to **AC2 Gen/Grid N<sub>TT</sub>**.
  - Connect the grounding conductor to **AC2 Gen/Grid PE**.

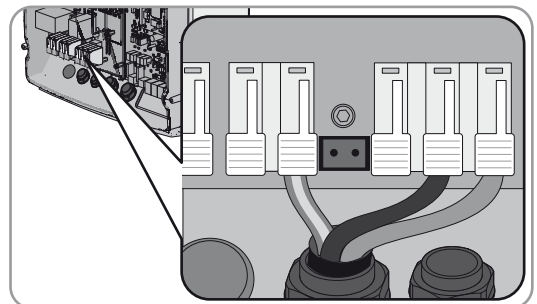

### 7.4.3.3 Connecting the Control Cables to the Automatic Transfer Switch

Control cables conduct the control signals of the multifunction relays to the contactors (for circuitry overview see Quick Reference Guide "Battery Backup System").

#### Procedure:

1. Connect the cable of **X5 L1** and **X5 N** for the control voltage to the terminal master **AC1 Loads/SunnyBoys**. Ensure that the cable is correctly connected (see Section 7.5.2 "Connecting the AC Power Cable", page 54).

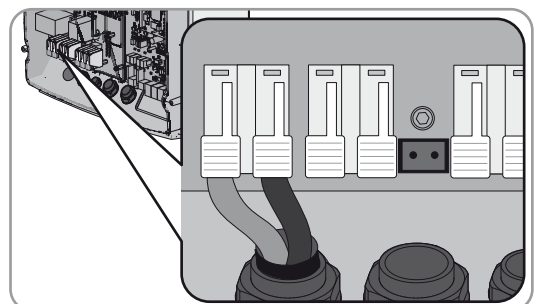

2. **⚠ WARNING****Danger to life from electric shock due to incorrect insulation**

- Connect the control cable of **X4 1** and **X4 2** to the **Relay 1 C** and **Relay 1 NC** terminals. Ensure that the cable is correctly connected (see Section 7.5.5 "Connecting Relay 1 and Relay 2", page 57).

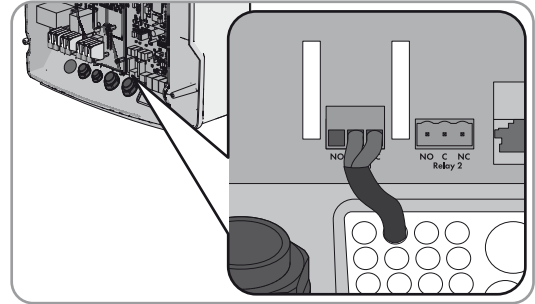
3. **⚠ WARNING****Danger to life from electric shock due to incorrect insulation**

- Connect the control cable of **X5 1** and **X5 2** to the **Relay 2 C** and **Relay 2 NO** terminals. Ensure that the cable is correctly connected (see Section 7.5.5 "Connecting Relay 1 and Relay 2", page 57).

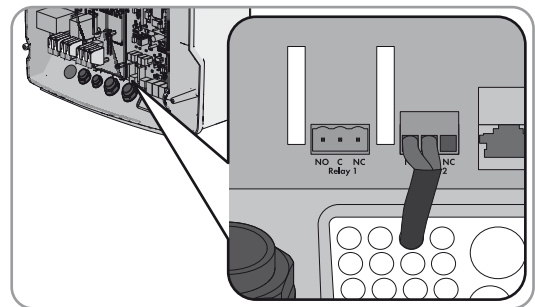

### 7.4.3.4 Connecting the Measuring Cables to the Automatic Transfer Switch

The Sunny Island measures the voltages of the respective line conductors via one measuring cable. In addition, the master measures whether the tie switch has activated or deactivated (for circuitry overview see Quick Reference Guide "Battery Backup System").

**Procedure:**

1. On the Sunny Island connect the measuring cable **X4 Ln \*** and **X4 N** for voltage monitoring to the **ExtVtg** terminal. Ensure that the cable is correctly connected (see Section 7.5.7 "Connecting ExtVtg", page 58).

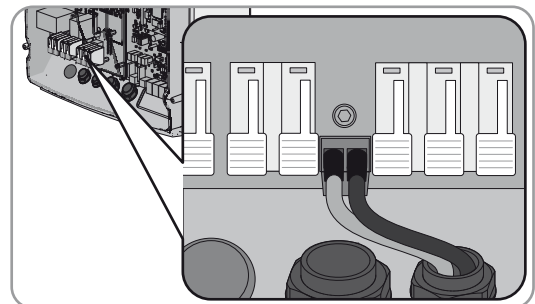

2. Connect the monitoring of the tie switch to the master. Ensure that the cable from **X5 3** and **X5 4** is correctly connected (see Section 7.5.6 "Connecting BatVtg, DigIn, BatTMP and BatCur", page 58).
  - Connect **BatVtgOut** – with **DigIn** – within the master.
  - Connect insulated conductor from **X5 3** to **DigIn+**.
  - Connect the insulated conductor from **X5 4** to **BatVtgOut+**.

---

\* Ln = L1 to L3

### 7.4.4 Connecting the Stand-Alone Grid or Multicluster Box

In off-grid systems you connect AC loads and the grid-parallel AC sources (e.g. PV inverters) using an AC sub-distribution board to the **AC1** terminal of the Sunny Island. In the case of a multicluster system, the Multicluster Box is the AC distribution board that is connected to the **AC1** terminal.

**Requirements for connecting Sunny Island inverters in single-phase parallel single-cluster systems:**

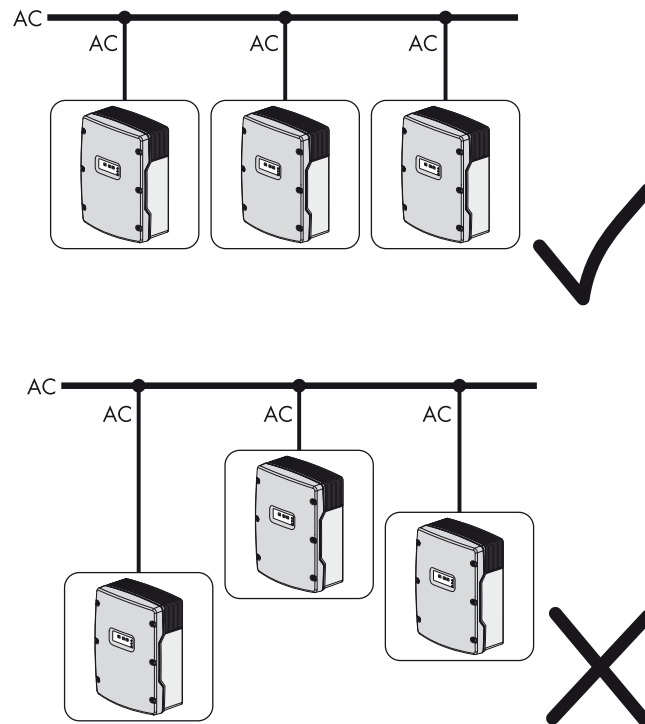

Figure 9: Correct, symmetric connection and incorrect, asymmetric connection of the Sunny Island inverters

- For a single-phase parallel single-cluster system, the cable length and conductor cross-section from each Sunny Island to the AC distribution board must be identical. This will allow for stable and symmetric operation.

#### ⚠ WARNING

##### Danger to life due to fire

In case of a short circuit, the short-circuit current driven by the generator flows over the unfused cable between the Sunny Island and the AC distribution board. Short-circuit currents can cause fires.

- If the generator fuse rating is greater than the fuse rating in the AC distribution board, the cable must be dimensioned to the generator fuse.

#### Procedure:

1. On the Sunny Island connect the cable to the **AC1 Loads/SunnyBoys** terminal. Ensure that the cable is correctly connected (see Section 7.5.2 "Connecting the AC Power Cable", page 54).

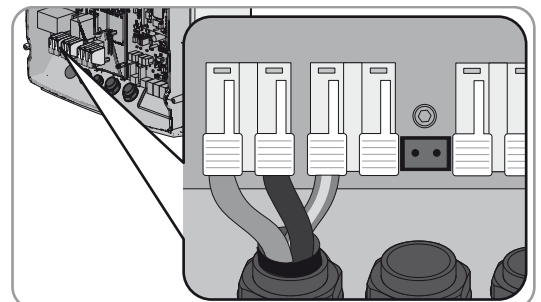

2. If the conductor cross-section of the grounding conductor is smaller than 10 mm<sup>2</sup>, make sure that an additional grounding conductor is connected to terminal **AC2 Loads/SunnyBoys PE** (see Section 7.5.3 "Connecting the Grounding Conductor", page 55).

### 7.4.5 Connecting the Generator in an Off-Grid System

For a single system and single-cluster system, connect the generator to the **AC2** terminal of the Sunny Island. For a multicluster system, connect the generator directly to the Multicluster Box (see the Multicluster Box documentation).

#### ⚠ WARNING

#### Danger to life from electric shock due to incorrect connection of the neutral conductor

Connecting the neutral conductor incorrectly can cause failure of the protective functions in the system. This can result in death or serious injury.

- Connect the neutral conductor to terminal **AC2 Gen/Grid N**.

#### Requirements:

- A separate cable must be laid for each Sunny Island from the AC distribution board or directly from the generator.
- For a single-phase parallel system, the cable length and the conductor cross-section must be identical from each Sunny Island to the AC distribution board or directly to the generator.
- For a three-phase system, L1 must be assigned to the master, L2 to slave 1 and L3 to slave 2.

#### Procedure:

- Connect the power cable to the **AC2 Gen/Grid** terminal on the Sunny Island. Connect the neutral conductor to the terminal **N** and ensure that the cable is correctly connected (see Section 7.5.2 "Connecting the AC Power Cable", page 54).

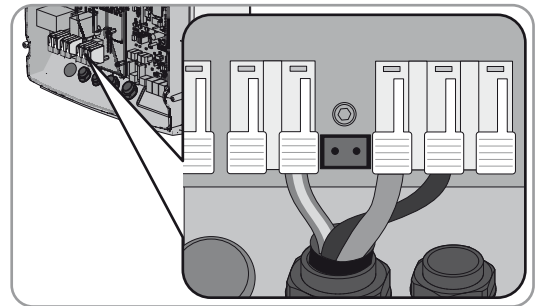

### 7.4.6 Inserting Filler-Plugs

- Seal unused enclosure openings of the Sunny Island with filler plugs. The enclosure openings will then comply with degree of protection IP54.



## 7.4.7 Communication Connection

### 7.4.7.1 Connecting the Sunny Remote Control

A data cable is included with the Sunny Remote Control for connection purposes. If the data cable is not long enough, you can replace it with a longer data cable.

#### Cable requirements:

- Maximum cable length: maximum 20 m
- Classification: CAT5e
- Type of plug: RJ45

#### Procedure:

1. Insert the data cable in the pin connector **Display** on the Sunny Island (see Section 7.5.4 "Connecting the Data Cables", page 56).

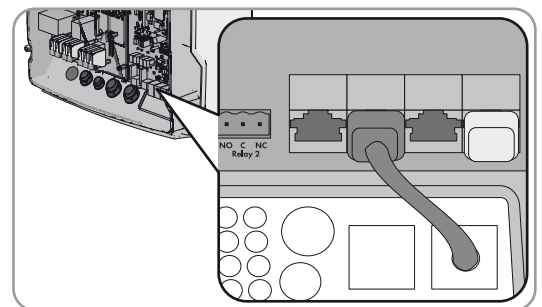

2. Connect the other end of the data cable to the Sunny Remote Control.

### 7.4.7.2 Connecting the Data Cable of the Lithium-Ion Batteries

#### Requirement:

- The total length of the communication bus must not be greater than 30 m. Keep in mind that the communication bus possibly connects several nodes such as additional Sunny Island inverters.

#### Cable requirements:

- Classification: CAT5e
- Type of plug: RJ45

#### Procedure:

1. Plug the data cable into a free pin connector **ComSync** on the Sunny Island. Ensure that the cable is correctly connected (see Section 7.5.4 "Connecting the Data Cables", page 56).

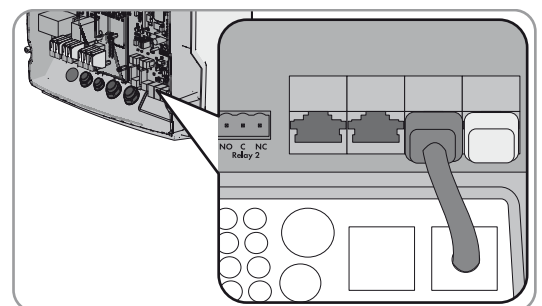

2. Connect the other end of the data cable to the battery management of the lithium-ion battery (see battery manufacturer documentation).
3. Ensure that the communication bus is closed at each end, e.g. with a terminator.

### 7.4.7.3 Connecting Speedwire

#### Requirement:

- A Speedwire data module for Sunny Island must be installed (see the installation manual of the SMA Speedwire/ Webconnect data module).

**Cable requirements:**

- Maximum cable length: maximum 100 m
- Cross-section: at least 2 x 2 x 0.22 mm<sup>2</sup> or at least 2 x 2 AWG 24
- Cable type: 100BaseTx, CAT5 with shielding S-UTP, F-UTP or higher
- UV-resistant for outdoor use
- Type of plug: RJ45

**Procedure:**

1. On the Sunny Island insert the data cable in the pin connector of the Speedwire data module (for electrical connection, see the installation manual of the Speedwire data module Sunny Island).

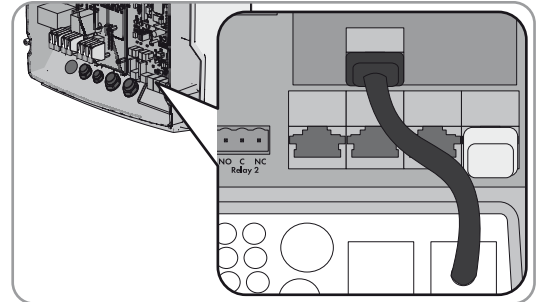

2. Connect the other end of the data cable to the router or network switch.

**7.4.7.4 Connecting the Data Cable for the Internal Communication of the Cluster**

In a cluster, the Sunny Island inverters communicate internally via a black data cable.

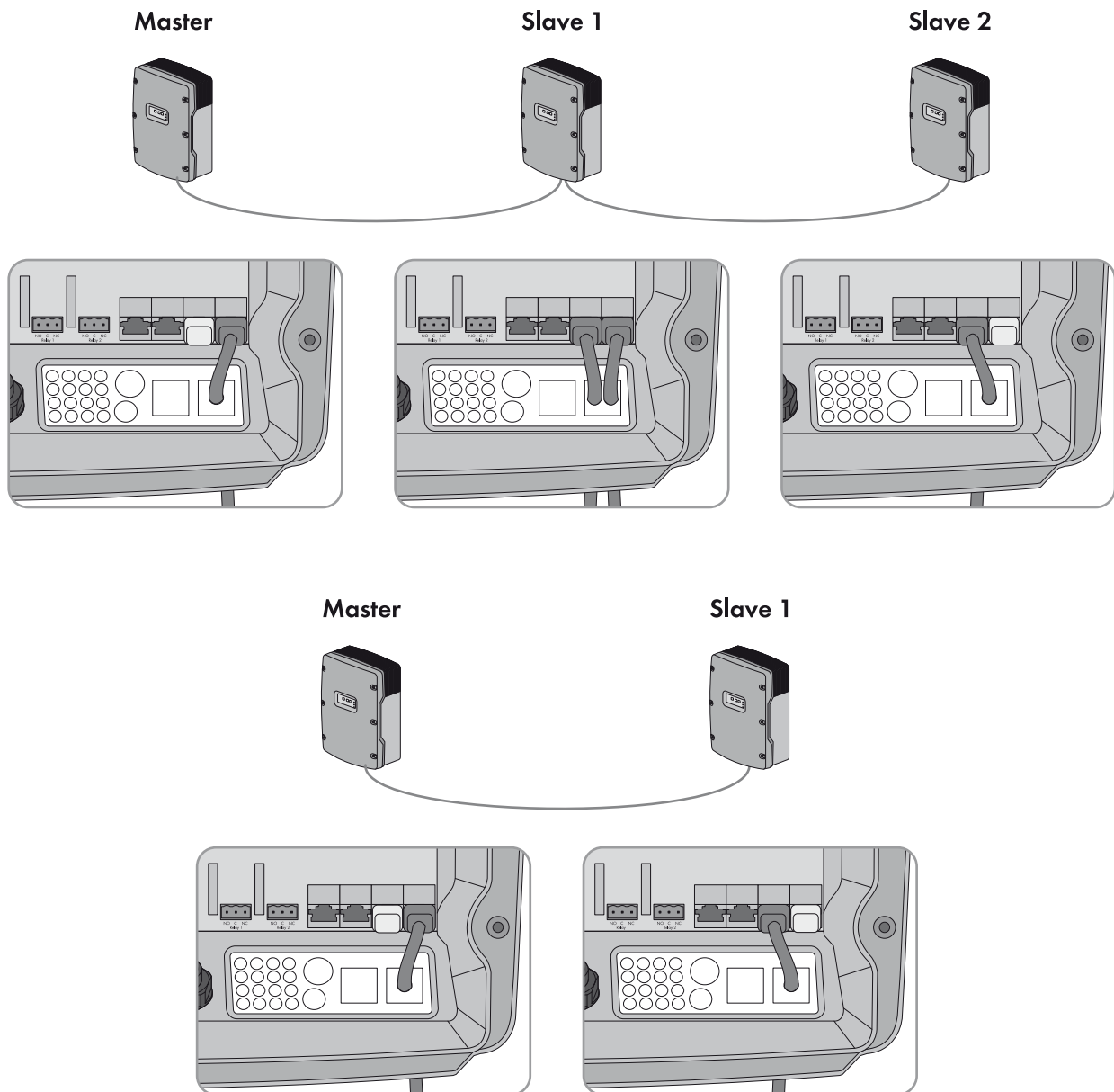

Figure 10: Internal communication cabling

**Requirements:**

- The total length of the communication bus must not be greater than 30 m. Keep in mind that the communication bus possibly connects several other users such as other Sunny Island Charger.

**Procedure:**

1. Plug the data cable into a free pin connector **ComSync** on the Sunny Island. Ensure that the cable is correctly connected (see Section 7.5.4 "Connecting the Data Cables", page 56).

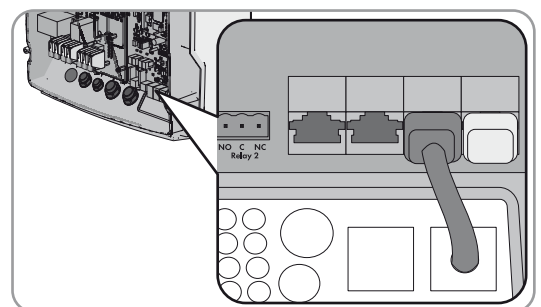

2. Ensure that the communication bus is closed at each end, e.g. with a terminator.

### 7.4.7.5 Connecting the Data Cable of the Sunny Island Charger 50

Up to four Sunny Island Charger 50 can be connected in an off-grid system (see Quick Reference Guide "Off-Grid Systems").

#### Requirements:

- The total length of the communication bus must not be greater than 30 m. Keep in mind that the communication bus possibly connects several nodes such as additional Sunny Island inverters.

#### Cable requirements:

- Classification: CAT5e
- Type of plug: RJ45

#### Procedure:

1. Plug the data cable into a free pin connector **ComSync** on the Sunny Island. Ensure that the cable is correctly connected (see Section 7.5.4 "Connecting the Data Cables", page 56).

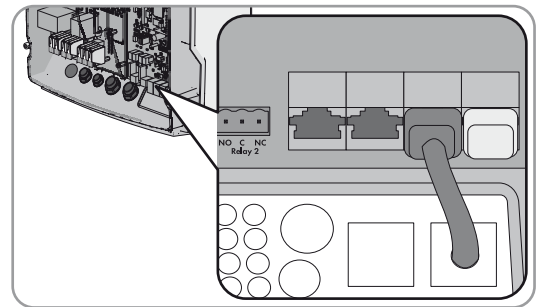

2. Connect the other end of the data cable to a Sunny Island Charger 50 and further Sunny Island Charger 50 devices with each other (see Sunny Island Charger 50 documentation).
3. Ensure that the communication bus is closed at each end, e.g. with a terminator.

### 7.4.7.6 Connecting the Data Cable of the Multicluster Box

For a multicluster system, the Multicluster Box communicates with the master of the main cluster via a black data cable (see Multicluster Box documentation). The black data cable is part of the scope of delivery of the Multicluster Box.

#### Requirements:

- The total length of the communication bus must not be greater than 30 m. Keep in mind that the communication bus connects several nodes such as additional Sunny Island inverters.

#### Cable requirements:

- Classification: CAT5e
- Type of plug: RJ45

#### Procedure:

1. Plug the data cable into a free **ComSync** pin connector on a Sunny Island of the main cluster. Ensure that the cable is correctly connected (see Section 7.5.4 "Connecting the Data Cables", page 56).

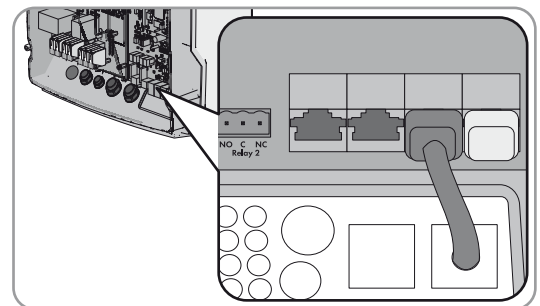

2. Connect the other end of the data cable to the Multicluster Box (see Multicluster Box documentation).
3. Ensure that the communication bus is closed at each end, e.g. with a terminator.

### 7.4.7.7 Connecting Control and Measuring Cables of the Multicluster Box

For a multicluster system, the Multicluster Box communicates control and measuring data with the three Sunny Island inverters of the main cluster via three red data cables (see Multicluster Box documentation). The red data cables are part of the scope of delivery of the Multicluster Box.

#### Procedure:

- Plug the red data cable into the pin connector **BackupVtgCur** on the Sunny Island units of the main cluster (see Section 7.5.4 "Connecting the Data Cables", page 56). Observe the following assignment:
  - Connect the master with the **Mstr./L1** terminal of the Multicluster Box.
  - Connect slave 1 with the **Slv1./L2** terminal of the Multicluster Box.
  - Connect slave 2 with the **Slv2./L3** terminal of the Multicluster Box.

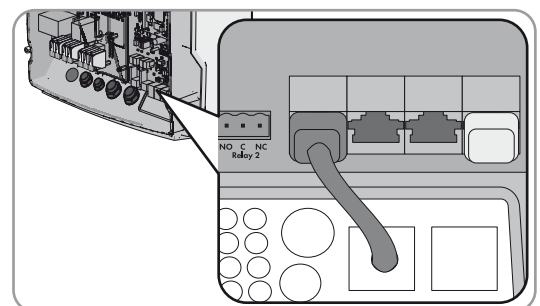

### 7.4.7.8 Connecting the Cable of the Multicluster Communication

In a multicluster system, the masters of the various clusters communicate with each other (see Multicluster Box documentation). An SI-SYSCAN.BGx communication interface must be installed in every master for Multicluster communication. This communication is not necessary for a multicluster system with one cluster. If the Sunny Island was ordered with the "Communication for multicluster system" order option, SI-SYSCAN.BGx is installed in every master.

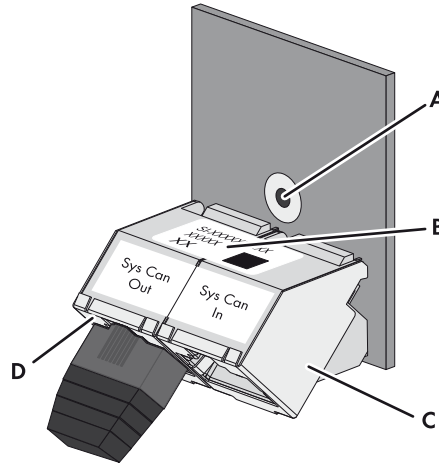

Figure 11: Design of the SI-SYSCAN.BGx

Position	Designation
A	Mounting hole
B	Type label
C	<b>SysCanIn</b> pin connector
D	<b>SysCanOut</b> pin connector

#### Cable requirements:

- Classification: CAT5e
- Maximum cable length: 50 m

#### Procedure:

1. If no SI-SYSCAN.BGx communication interface is installed, install SI-SYSCAN.BGx in each master (see SI-SYSCAN-NR documentation).
2. Remove the terminator from the **SysCanOut** pin connector on the master of the main cluster and plug it into the **SysCanIn** pin connector.
3. Plug the yellow data cable into the **SysCanOut** pin connector on the main cluster master (see Section 7.5.4 "Connecting the Data Cables", page 56).
4. Plug the other end of the yellow data cable into the **SysCanIn** pin connector on the master of the extension cluster 1.
5. Connect the other extension clusters with each other as described in steps 3 and 4. Remove the terminators for this.
6. Leave the terminator plugged into the unused **SysCanOut** pin connector. The communication bus is equipped with a terminating resistor at the end.

### 7.4.7.9 Connecting RS485

The SI-COMSMA.BGx communication interface is required for communication with a communication device (e.g. Sunny WebBox) or other SMA products (e.g. PV inverter). If the Sunny Island was ordered with the "Communication for RS485" order option, the SI-COMSMA.BGx is installed on every master.

#### Plug assignment:

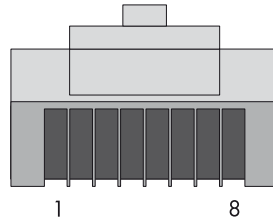

Figure 12: RJ45 plug assignment

Contact pin	Signal	Color coding of the insulated conductors
2	GND	Orange with white stripes
3	Data+ (A)	White with green stripes
6	Data – (B)	Green with white stripes

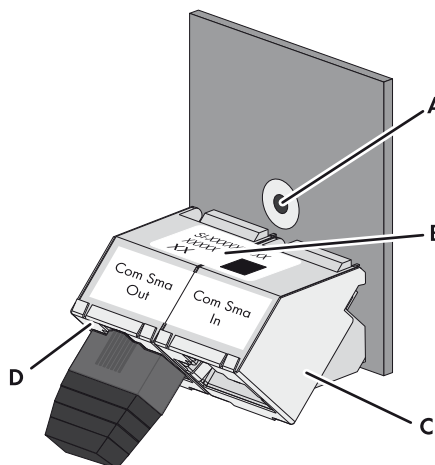

Figure 13: Design of the SI-COMSMA.BGx

Position	Designation
A	Mounting hole
B	Type label
C	<b>ComSmaIn</b> pin connector
D	<b>ComSmaOut</b> pin connector

#### Cable requirements:

- Classification: CAT5e
- Maximum cable length: 1,200 m

**Procedure:**

1. If an SI-COMSMA.BGx is not installed in the Sunny Island, install an SI-COMSMA.BGx in the Sunny Island (see SI-COMSMA-NR mounting instructions):
  - For single systems, install an SI-COMSMA.BGx in the Sunny Island.
  - For a single-cluster system, install an SI-COMSMA.BGx in the master.
  - For a multicluster system, install an SI-COMSMA.BGx in each master.
2. Connect the white data cable with open wires to the communication device (see installation manual of the communication device).
3. Plug the white data cable into the **ComSmaIn** pin connector on the Sunny Island (see Section 7.5.4 "Connecting the Data Cables", page 56).
4. For a single-cluster system plug the white data cable into the **ComSmaIn** pin connector on the master (see Section 7.5.4 "Connecting the Data Cables", page 56).
5. For a multicluster system, connect the masters to each other:
  - Remove the terminator from the **ComSmaOut** pin connector on the master of the main cluster.
  - Plug the gray data cable into the **ComSmaOut** pin connector on the master of the main cluster.
  - Plug the gray data cable into the pin connector **ComSmaIn** on the master of the extension cluster 1.
  - Connect the other extension clusters with each other as described.
6. Leave the terminator plugged into the unused **ComSmaOut** pin connector. The communication bus is equipped with a terminating resistor at the end.

### 7.4.8 Connecting the Battery Temperature Sensor

The Sunny Island battery management must capture the temperature of the connected battery for lead-acid batteries.

#### **i** Battery temperature sensor in a cluster

Only the master measures the battery temperature in a cluster.

- Connect the battery temperature sensor only to the master.

#### **NOTICE**

##### Damage to the battery due to excessive charging voltage

Due to incorrect temperature measurements, the Sunny Island charges the battery with an incorrect charging voltage.

- Connect only the battery temperature sensor supplied.
- Attach the battery temperature sensor in the middle of the battery bank, in the upper third of the battery cell. As a result, the battery temperature sensor measures the warmest point in the battery bank.

**Procedure:**

- On the Sunny Island connect both insulated conductors of the sensor to the **BatTmp** terminal (see Section 7.5.6 "Connecting BatVtg, DigIn, BatTMP and BatCur", page 58). In this case, the polarity is arbitrary.

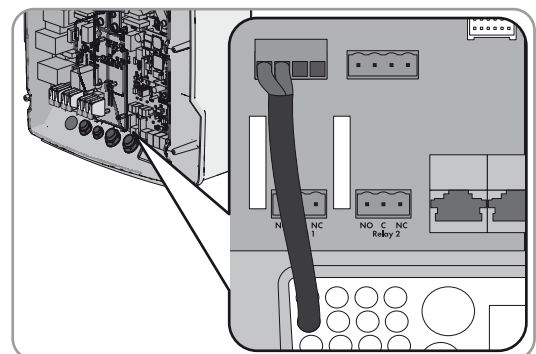



### 7.4.9 Connecting the Battery Current Sensor

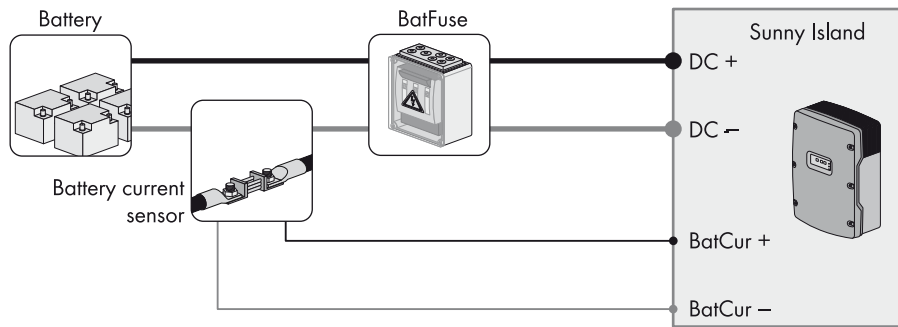

Figure 14: Connection of the battery current sensor to the Sunny Island.

#### Cable requirements:

- Copper wire
- Cable length: maximum 3 m
- Conductor cross-section: 0.2 mm<sup>2</sup> to 2.5 mm<sup>2</sup>
- A measuring cable with intrinsically safe current circuits must be used. In this case, "intrinsically safe" means that the cable is double-insulated and that, in the event of a short circuit, the conductor melts but the insulation remains intact. In addition, the cable is not combustible.
- Conductors in the measuring cable must be twisted.

#### Procedure:

1. Install the battery current sensor on the **DC-** power cable between the battery and BatFuse.
2. Connect the **BatCur+** measuring conductors to the side for connecting the BatFuse on the battery current sensor.

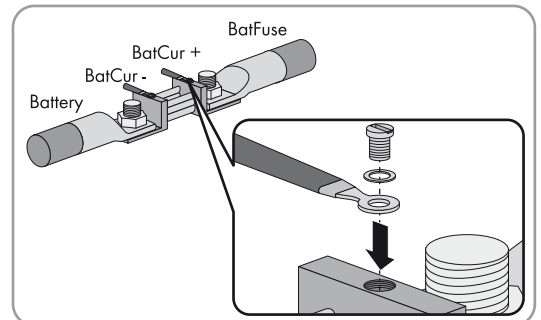

3. Connect the **BatCur-** measuring conductor to the side for connecting the battery on the battery current sensor.

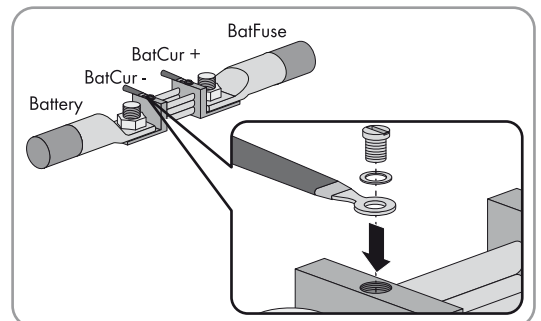

4. On the Sunny Island connect the conductors to the terminals **BatCur +** and **BatCur -**. Ensure that the cable is correctly connected (see Section 7.5.6 "Connecting BatVtg, DigIn, BatTMP and BatCur", page 58).

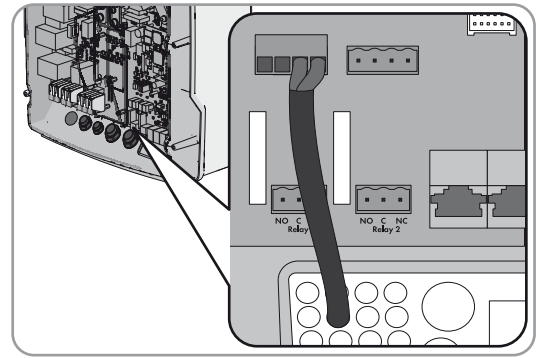

### 7.4.10 Connecting the Control Cable for Autostart Generators

Autostart generators are started and stopped by a contact.

#### **i** Generator control in a cluster

Slaves control the generator less reliably than masters do.

- Connect the generator control to the master preferably.
- If the off-grid system is a multicluster system, always connect the generator control to the master of the main cluster.



Figure 15: Connection of the generator control to the Sunny Island

#### Requirements:

- The technical requirements of the multifunction relay must be met (see Section 10 "Technical Data", page 97).

#### Cable requirements:

- Copper wire
- Conductor cross-section: 0.2 mm<sup>2</sup> to 2.5 mm<sup>2</sup>

#### Procedure:

##### 1. **⚠ WARNING**

#### Danger to life from electric shock due to incorrect insulation

- On the Sunny Island, connect the control cable either to the multifunction relay **Relais1** or **Relais2** (see Section 7.5.5 "Connecting Relay 1 and Relay 2", page 57). Use the **C** and **NO** terminals.

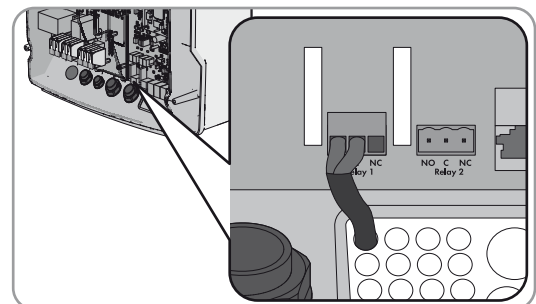

2. Go to Section 8.1.5, page 67 and enter **AutoGn** in the table for configuration.

### 7.4.11 Connecting a Signal Generator for Generators without Autostart Function

Generators without an autostart function do not have electric starting devices. If you install a generator without an autostart function, you can connect a signal generator (e.g. signal lamp) to the multifunction relay of the Sunny Island. As a result, the Sunny Island can signal when the generator is to be manually started and stopped.

#### **i** Connecting a signal generator in a cluster

Slaves control the generator less reliably than masters do.

- Connect the generator control to the master preferably.
- In a multicenter system, always connect the signal generator to the master of the main cluster.

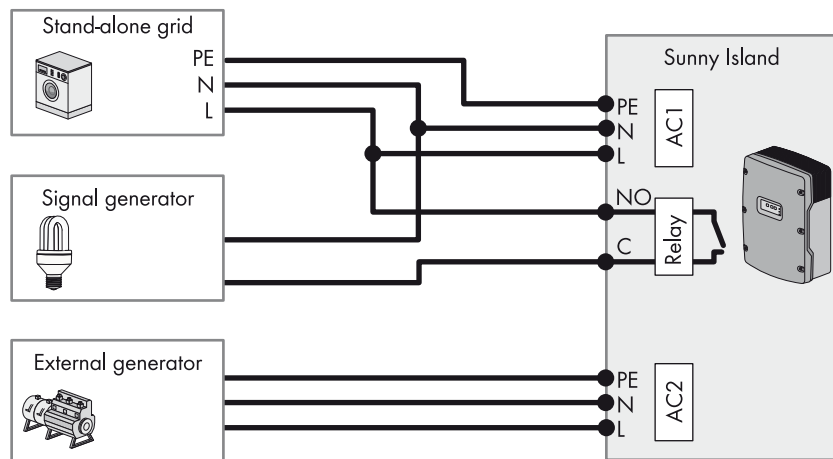

Figure 16: Connection of a signal generator for signaling the generator request (example)

#### Requirements:

- The technical requirements of the multifunction relay must be met (see Section 10 "Technical Data", page 97).

#### Cable requirements:

- Copper wire
- Conductor cross-section: 0.2 mm<sup>2</sup> to 2.5 mm<sup>2</sup>

#### Procedure:

##### 1. **⚠ WARNING**

#### Danger to life from electric shock due to incorrect insulation

- On the Sunny Island, connect the control cable either to the multifunction relay **Relais1** or **Relais2** (see Section 7.5.5 "Connecting Relay 1 and Relay 2", page 57). Use the **C** and **NO** terminals.

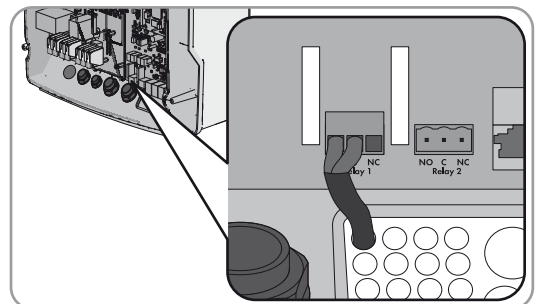

2. Go to Section 8.1.5, page 67 and enter **AutoGn** in the table for configuration.

## 7.4.12 Connecting Load-Shedding Contactors

Load shedding prevents the battery deep discharge and controls the power output to the loads. Load shedding provides the option of disconnecting specific loads from the system.

The load shedding is necessary for an off-grid system that is exclusively supplied with PV energy or wind energy.

The Sunny Island controls up to two load-shedding contactors depending on the state of charge of the battery. You can install two types of load shedding:

- 1-level load shedding

If the limit of the state of charge of the battery is reached, one load-shedding contactor disconnects all loads at the same time. Depending on the configuration, the load-shedding contactor closes when the battery has been sufficiently charged or when the stand-alone grid has been switched to an external energy source.

- 2-level load shedding

For 2-level load shedding, there are two limits for the state of charge of the battery in order to control two load-shedding contactors. When the first threshold for the state of charge of the battery is reached, the first load-shedding contactor disconnects a group of loads. When the second threshold for the state of charge of the battery is reached, the second load-shedding contactor disconnects the remaining loads.

### **i** Load shedding in a multicluster system

1-level load shedding is integrated into the Multicluster Box. The load-shedding contactor is controlled directly by the master of the main cluster by via communication with the Multicluster Box. If you install an additional load-shedding contactor in a multicluster system, it is controlled with a multifunction relay in the master of extension cluster 1. Additional load-shedding contactors cannot be controlled by the main cluster.

### **i** Load-shedding contactors in a cluster

If you connect load-shedding contactors to the master, limited operation is possible in the event of a disturbance. Slaves can control the load-shedding contactors less reliably in the event of a fault. In case of a disturbance, the slave waits for confirmation from the master, if necessary.

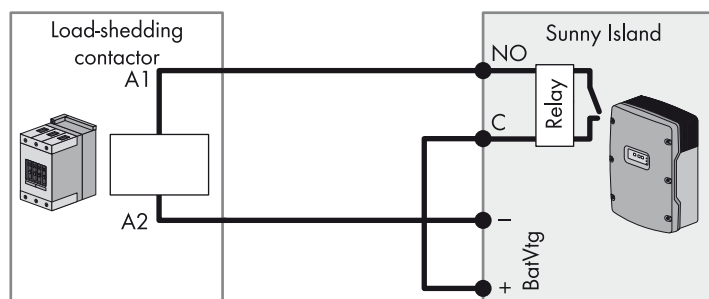

Figure 17: Connection of the control cable for 1-level load shedding (example)

#### Requirements:

- The technical requirements of the multifunction relay must be met (see Section 10 "Technical Data", page 97).

#### Cable requirements:

- Copper wire
- Conductor cross-section: 0.2 mm<sup>2</sup> to 2.5 mm<sup>2</sup>

#### Procedure:

1. Ensure that the load-shedding contactor only disconnects loads from the system. This ensures that the battery can be recharged from AC sources in the system.
2. Connect the insulated conductor for coil connection **A1** of the first load-shedding contactor to the **Relay 1 NO** terminal (see Section 7.5.5 "Connecting Relay 1 and Relay 2", page 57).

3. Connect the insulated conductor for the **A2** coil connection to the **BatVtg** – terminal (see Section 7.5.6 "Connecting BatVtg, DigIn, BatTMP and BatCur", page 58).
4. Connect the **BatVtg +** terminal to the **Relay1 C** terminal. Use the same conductor cross-section as that of the cable for the load-shedding contactor.
5. Go to Section 8.1.5, page 67 and enter the following values in the table for configuration 1.

Value	Explanation
AutoLodExt	Setting for 1-level load shedding. When the Sunny Island switches to an external energy source, load shedding is stopped and the loads are supplied by the external energy source. The battery is only charged with excess energy.
AutoLod1 Soc	Setting for 1-level load shedding or the first level of 2-level load shedding. Load shedding is only stopped when the battery has been sufficiently charged.
AutoLod2Soc	Setting for the second level of 2-level load shedding. Load shedding is only stopped when the battery has been sufficiently charged.
MccAutoLod	Setting for additional 1-level load shedding in a multicluster system. Load shedding is only stopped when the batteries of the extension cluster have been sufficiently charged.

6. Repeat steps 1 to 5 for 2-level load shedding. Connect the second load-shedding contactor to an unused multifunction relay.

### 7.4.13 Connecting the Time Control for External Processes

The Sunny Island has two timers for time-dependent control of external processes. For each timer, you can set the starting day and time that the multifunction relay is to be switched once, daily or weekly.

#### Requirements:

- The technical requirements of the multifunction relay must be met (see Section 10 "Technical Data", page 97).

#### Cable requirements:

- Copper wire
- Conductor cross-section: 0.2 mm<sup>2</sup> to 2.5 mm<sup>2</sup>

#### Procedure:

##### 1. **⚠ WARNING**

#### Danger to life from electric shock due to incorrect insulation

- On the Sunny Island connect the control cable either to multifunction relay **Relais1** or **Relais2** (see Section 7.5.5 "Connecting Relay 1 and Relay 2", page 57). Use the **C** and **NO** terminals.

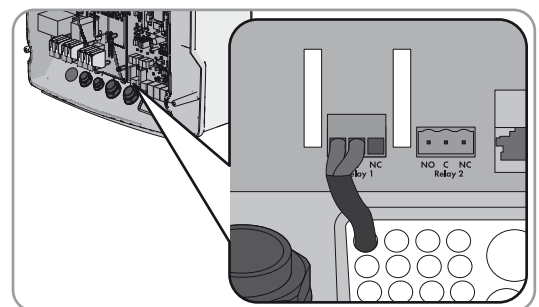

2. Go to Section 8.1.5, page 67 and enter the value **TM1** for timer 1 or the value **TM2** for timer 2 in the table for configuration.

### 7.4.14 Connecting Message Devices for Operating States and Warning Messages

You can connect message devices to the multifunction relay to display operating states and warning messages of the Sunny Island. One of the following operating states and warning messages can be displayed for each multifunction relay:

- The generator is running and is connected.
- Voltage and frequency of the utility grid are within the range for connection.
- A Sunny Island displays an error message of level 2 or higher. Only the error messages within a cluster are evaluated here.

#### **i** Different control logic for error messages of level 2 or higher

- When an error message of level 2 is pending, the multifunction relay is deactivated.
- When no error message is pending, the multifunction relay is activated.

This ensures that the error message will also be displayed in the case of automatic shutdown.

- The Sunny Island displays a warning. Only the warnings within a cluster are evaluated here.
- The Sunny Island is in operation in the single system.
- The respective cluster is in operation in a cluster system.
- The Sunny Island is in derating in a single system.
- The respective cluster is in derating in a cluster system.

#### Requirements:

- The technical requirements of the multifunction relay must be met (see Section 10 "Technical Data", page 97).

#### Cable requirements:

- Copper wire
- Conductor cross-section: 0.2 mm<sup>2</sup> to 2.5 mm<sup>2</sup>

#### Procedure:

##### 1. **⚠ WARNING**

#### Danger to life from electric shock due to incorrect insulation

- On the Sunny Island connect the control cable either to multifunction relay **Relais 1** or **Relais 2** (see Section 7.5.5 "Connecting Relay 1 and Relay 2", page 57). Use the **C** and **NO** terminals.

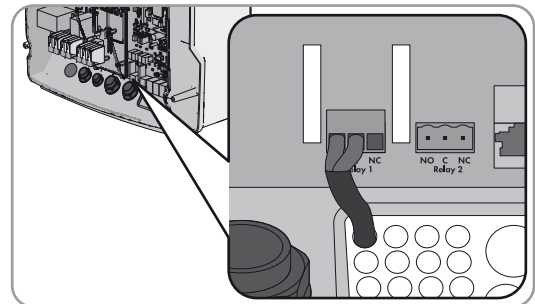

2. Go to Section 8.1.5, page 67 and enter the following values in the table for configuration 1.

Value	Display
GnRn	The generator is running and is connected.
ExtVfOk	Voltage and frequency of the generator are within the range for connection.
GdOn	The utility grid is connected in the off-grid system.
Error	A Sunny Island displays an error message of level 2 or higher.
Warn	The Sunny Island displays a warning.
Run	In a single system the Sunny Island is operating or the cluster is operating in a cluster system.
Overload	In a single system a Sunny Island is in derating or the cluster is in derating in a cluster system.

### 7.4.15 Connecting the Battery Room Fan

If the charging current leads to the emission of gases from the battery, the battery room fan is switched on by the Sunny Island for at least one hour.

#### Requirements:

- The technical requirements of the multifunction relay must be met (see Section 10 "Technical Data", page 97).

#### Cable requirements:

- Copper wire
- Conductor cross-section: 0.2 mm<sup>2</sup> to 2.5 mm<sup>2</sup>

#### Procedure:

The Sunny Island battery management can control one battery room fan per battery. The following options result for the connection:

- Control a separate battery room fan for each battery.
- Control one battery room fan for all batteries.  
This is only an option with multicluste systems.

### Controlling a Separate Battery Room Fan for Each Battery

1. Ensure that the battery room is sufficiently ventilated in the case of a malfunction of the multifunction relay.
2. **⚠ WARNING**

#### Danger to life from electric shock due to incorrect insulation

- With single systems or single-cluster systems:
  - Connect the battery room fan to a multifunction relay (see Section 7.5.5 "Connecting Relay 1 and Relay 2", page 57).

- Go to Section 8.1.5, page 67 and enter **BatFan** in the table for configuration.

- With a multicluste system:

- In each cluster connect one battery room fan to one Sunny Island to any multifunction relay (see Section 7.5.5 "Connecting Relay 1 and Relay 2", page 57).
- Go to Section 8.1.5, page 67 and enter **BatFan** in the table for configuration.

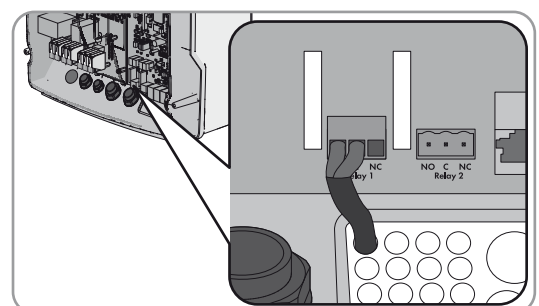

## Controlling One Battery Room Fan for All Batteries

1. Ensure that the battery room is sufficiently ventilated in the case of a malfunction of the multifunction relay.

### 2. **⚠ WARNING**

#### Danger to life from electric shock due to incorrect insulation

- Connect the battery room fan to one multifunction relay on a Sunny Island of the main cluster (see Section 7.5.5 "Connecting Relay 1 and Relay 2", page 57).

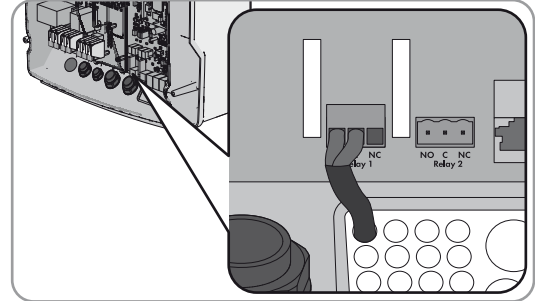

3. Go to Section 8.1.5, page 67 and enter **MccBatFan** in the table for configuration.

## 7.4.16 Connecting the Electrolyte Pump for the Battery

The Sunny Island controls the electrolyte pump for the battery as follows:

- The Sunny Island switches on the electrolyte pump at least once a day.
- The Sunny Island switches on the electrolyte pump nine times a day at the maximum.
- When the battery has been charged to 10% of its rated capacity, the Sunny Island switches the electrolyte pump on for five minutes.

### Requirements:

- The technical requirements of the multifunction relay must be met (see Section 10 "Technical Data", page 97).

### Cable requirements:

- Copper wire
- Conductor cross-section 0.2 mm<sup>2</sup> to 2.5 mm<sup>2</sup>

### Procedure:

### 1. **⚠ WARNING**

#### Danger to life from electric shock due to incorrect insulation

1. On the Sunny Island connect the control cable of the acid circulation to a multifunction relay (see Section 7.5.5 "Connecting Relay 1 and Relay 2", page 57).

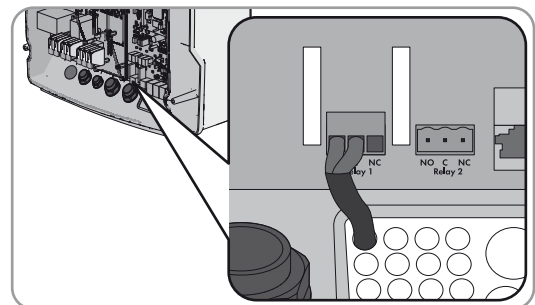

2. For a multicluster system, repeat step 1 for every cluster.

3. Go to Section 8.1.5, page 67 and enter **AcdCir** in the table for configuration.



### 7.4.17 Connecting the Control Cable for the Use of Excess Energy in an Off-Grid System

If the battery can no longer take up excess energy in an off-grid system, the power output of the AC sources in the stand-alone grid is limited by the Sunny Island. The excess energy is not used then. The Sunny Island allows for the use of excess energy by means of a multifunction relay.

During the constant voltage phase, a multifunction relay is activated and thus controls additional loads that can put any excess energy to good use. As a result of the utilization of excess energy, the Sunny Island has to limit the power output of the AC sources in the stand-alone grid to a less extent.

---

#### Example: Utilization of excess energy

The energy source of an off-grid system is PV energy. On days with high solar irradiation and low power consumption, the battery cannot take up all of the PV energy during the constant voltage phase. In order to utilize the excess energy, the Sunny Island activates the control of a pump that pumps water into a container for subsequent use.

---

#### Requirements:

- The technical requirements of the multifunction relay must be met (see Section 10 "Technical Data", page 97).

#### Cable requirements:

- Copper wire
- Conductor cross-section: 0.2 mm<sup>2</sup> to 2.5 mm<sup>2</sup>

#### Procedure:

##### 1. **⚠ WARNING**

#### Danger to life from electric shock due to incorrect insulation

- On the Sunny Island connect the control cable for the utilization of excess energy to the multifunction relay (see Section 7.5.5 "Connecting Relay 1 and Relay 2", page 57).

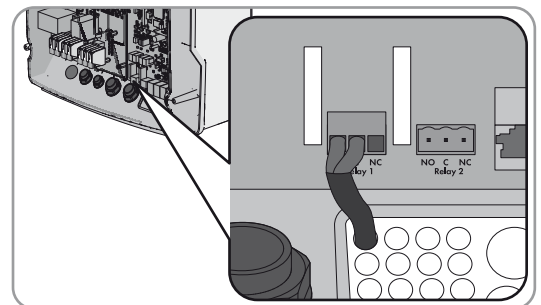

2. Enter the function of the multifunction relay used in the configuration table (see Section 8.1.5 "Setting the Functions of the Multifunction Relays", page 67). Note the **ExtPwrDer** value.

### 7.4.18 Connecting the Signal Cable of the External Generator Request

An external control signal can communicate a generator request to the generator management. If you have configured the generator management for the external generator request, the generator management starts the generator if there is a high level present. The generator management stops the generator if there is a low level. As a result, all generator run-times are met.

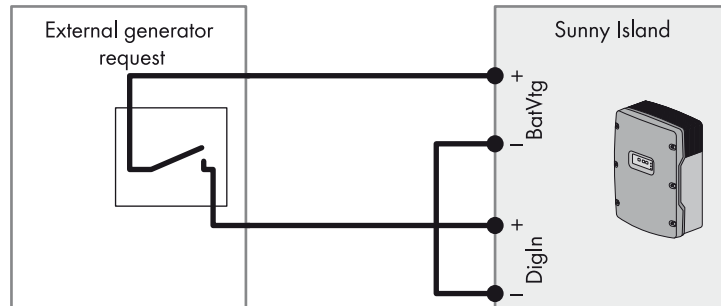

Figure 18: Connection of the control cable of an external generator request (example).

#### Requirements:

- The technical requirements of the digital input must be complied with (see Section 10 "Technical Data", page 97).

#### Cable requirements:

- Copper wire
- Conductor cross-section: 0.2 mm<sup>2</sup> to 2.5 mm<sup>2</sup>

#### Procedure:

1. Connect one insulated conductor of the control cable to the **BatVtg +** terminal on the Sunny Island (see Section 7.5.6 "Connecting BatVtg, DigIn, BatTMP and BatCur", page 58).
2. Connect one insulated conductor of the control cable to the **DigIn +** terminal
3. Connect the **BatVtg-** terminal with the **DigIn -** terminal. For this purpose, use the same conductor as in the control cable.

## 7.5 Connecting the Cables

### 7.5.1 Connecting the DC Power Cable

**Additionally required material (not included in the scope of delivery):**

- Ethanol
- 2 terminal lugs M8, 20 mm to 25 mm wide

**Cable requirements:**

- Conductor cross-section: 50 mm<sup>2</sup> to 95 mm<sup>2</sup>
- Cable diameter: 14 mm to 25 mm

#### **⚠ WARNING**

##### **Danger to life due to incompatible lithium ion-battery**

An incompatible lithium-ion battery can lead to a fire or an explosion. With incompatible lithium-ion batteries, it is not ensured that the battery management will protect the battery.

- Ensure that the battery is from one of the following manufacturers and has been approved for Sunny Island by the manufacturer:
  - Akasol
  - Dispatch Energy
  - LG Chem
  - Leclanché
  - SAFT
  - Samsung
  - Sony

This list is updated regularly (see Planning Guidelines "SMA Smart Home" at [www.SMA-Solar.com](http://www.SMA-Solar.com)).

#### **Procedure:**

1. Ensure that the load-break switch of the BatFuse is open and secured against reconnection.
2. Loosen all screws of the enclosure lid and remove the lid. Retain the screws and conical spring washers for later use.
3. Clean the contact surfaces of the **DC+** and **DC-** terminals e.g. with ethanol. This reduces the transition resistance on the contact surfaces. A low transition resistance increases the system stability and minimizes the risk of damage to the Sunny Island.
4. Strip the **DC+** cable and mount a terminal lug.
5. Attach two M32 cable glands with counter nuts to the **DC+** and **DC -** enclosure openings (torque: 12 Nm).

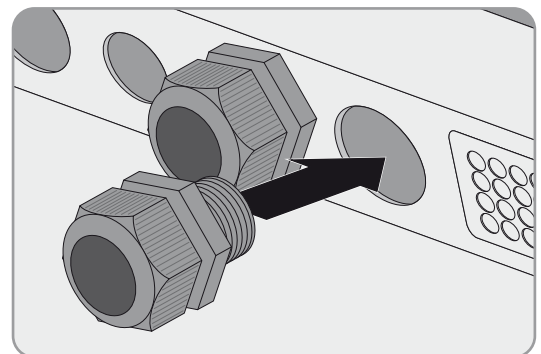

6. Lead the **DC+** cable through the **DC+** cable gland into the Sunny Island.

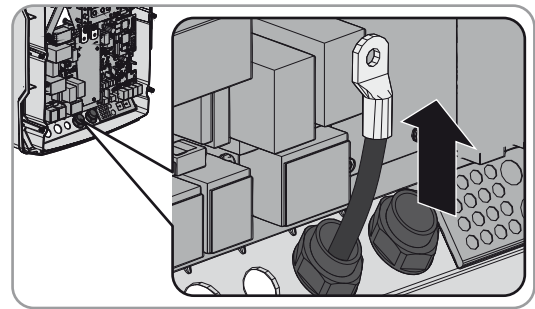

7. **NOTICE**

**Damage to the Sunny Island due to reverse polarity or wrong choice of terminal lug**

If the DC cables get swapped, high currents will flow after the load-break switch has closed that can damage the Sunny Island.

- Route the **DC+** cable on the side of the protective cover marked with a + symbol.
- Use an Allen key (AF 5) to fasten the **DC+** cable to the **DC+** terminal with an M8x20 screw (torque: 12 Nm). Be sure to adhere to the following screw assembly: screw head | spring washer | fender washer | terminal lug | DC terminal.

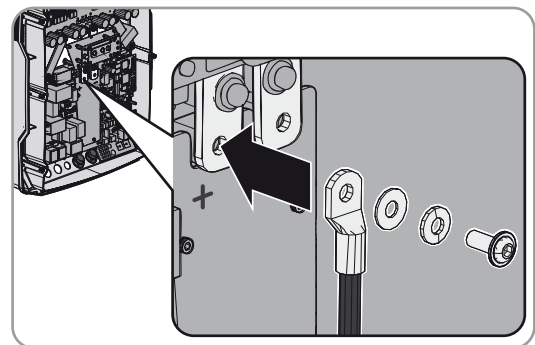

- The entire contact surface of the fender washer is in contact with the terminal lug.

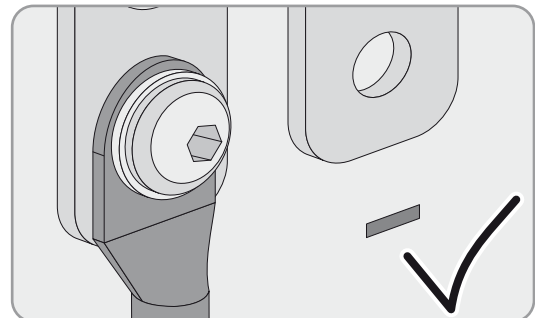

8. Strip the insulation off the **DC-** cable and mount a terminal lug.  
9. Lead the **DC-** cable through the **DC-** cable gland into the Sunny Island.

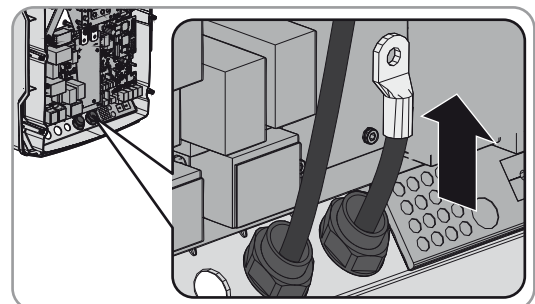

10. Route the **DC-** cable on the side of the protective cover marked with a - symbol.

11. Use an Allen key (AF 5) to fasten the **DC-** cable to the **DC-** terminal with an M8x20 screw (torque: 12 Nm). Be sure to adhere to the following screw assembly: screw head | spring washer | fender washer | terminal lug | DC terminal.

- The entire contact surface of the fender washer is in contact with the terminal lug.

12. Tighten the swivel nuts of the cable glands (torque 4.5 Nm).

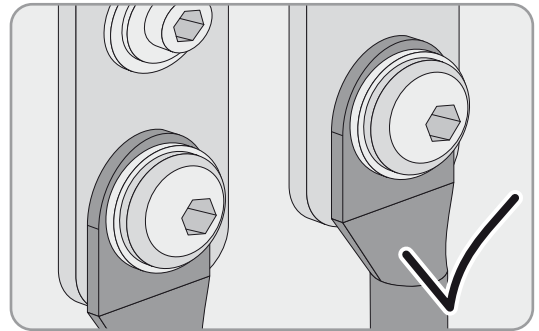
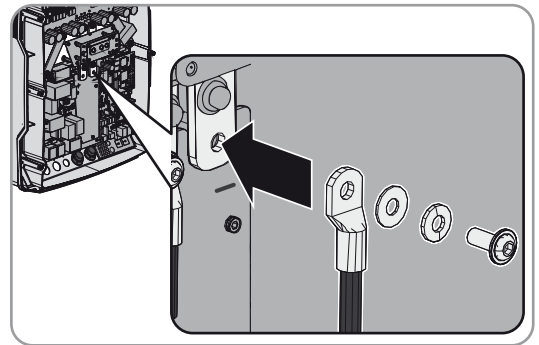

## 7.5.2 Connecting the AC Power Cable

Always connect the power cables in accordance with the following procedure.

### Cable requirements:

- Copper wire
- Conductor cross-section: maximum 16 mm<sup>2</sup>
- Cable diameter: 9 mm to 18 mm

### ⚠ WARNING

#### Danger to life from electric shock due to incorrect connection of the neutral conductor

The neutral conductor of the external energy source is firmly connected to the neutral conductor of the Sunny Island on terminal **AC2 Gen/Grid N**. When disconnecting the external energy source, the Sunny Island only disconnects the line conductor on terminal **AC2 Gen/Grid N**. The Sunny Island disconnects all poles from the external energy source on terminal **AC2 Gen/Grid N<sub>TT</sub>**. If the neutral conductor is incorrectly connected on terminal **AC2**, the protective functions in the system can fail. This can result in death or serious injury.

- Always connect the neutral conductor to the **AC2 Gen/Grid N<sub>TT</sub>** terminal in systems for increased self-consumption.
- Always connect the neutral conductor to the **AC2 Gen/Grid N<sub>TT</sub>** terminal in battery backup systems.
- Always connect the neutral conductor of the generator to the **AC2 Gen/Grid N** terminal in off-grid systems.

### Procedure:

1. Push the levers of the **AC1** or **AC2** terminal upward.
2. When connecting the cable to terminal **AC1**, attach the M25 cable gland to the **AC1** enclosure opening using the counter nut (torque: 7 Nm).

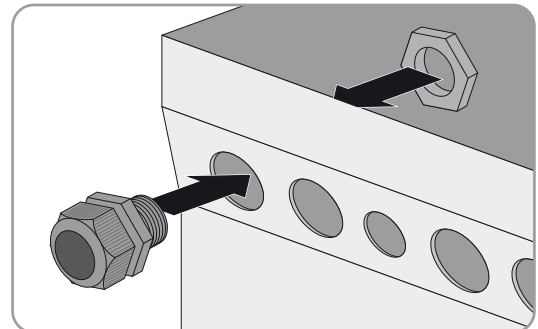

3. When connecting the cable to terminal **AC2**, attach the M25 cable gland to the **AC2** enclosure opening using the counter nut (torque: 7 Nm).

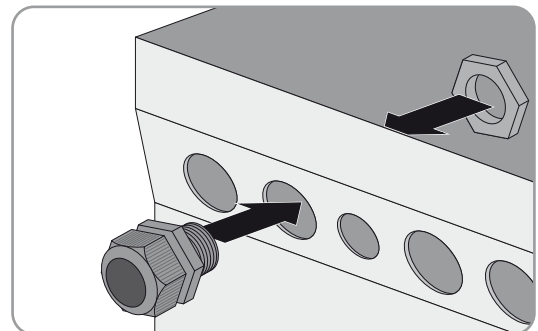

4. Remove the cable jacket and strip the wire insulation by 13 mm.
5. Lead the cable through the cable gland into the Sunny Island.
6. Connect the insulated conductors to the terminals **AC1 Loads/SunnyBoys** or **AC2 Gen/Grid**.
  - Insert the neutral conductor as far as it will go into terminal **N** or **N<sub>TT</sub>** and push the lever down.
  - Insert the line conductor as far as it will go into terminal **L** and push the lever down.
  - Insert the grounding conductor as far as it will go into terminal **PE** and push the lever down.
7. Tighten the swivel nut of the cable gland (torque: 4 Nm).

### 7.5.3 Connecting the Grounding Conductor

The Sunny Island must be connected via a grounding conductor on the **AC1** or **AC2** terminal to the ground potential. The conductor cross-section of the grounding conductor must be 10 mm<sup>2</sup> or larger. If the conductor cross-section is smaller, an additional grounding conductor must connect the Sunny Island with the ground potential.

Additional grounding is fulfilled if the Sunny Island is already grounded due to the grounded battery (see Section 7.3 "Connecting the Grounding Conductor in Systems with Grounded Battery", page 25).

#### Cable requirements:

- Conductor cross-section:
  - Cross-section of the connected line conductor or larger
  - Maximum 16 mm<sup>2</sup>
- Cable diameter: 7 mm to 14 mm

#### Procedure:

1. Push the lever of terminal **AC1 Loads/SunnyBoys PE** or **AC2 Gen/Grid PE** upward.
2. Attach the M20 cable gland to the **PE/ExtVtg** enclosure opening with the counter nut (torque: 5 Nm).

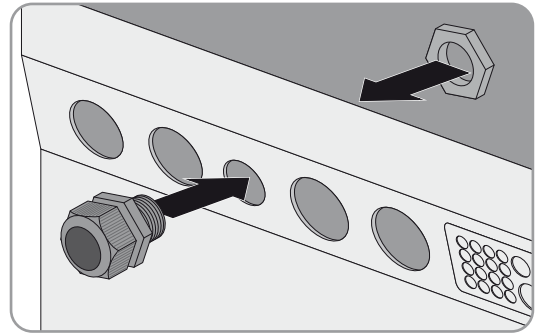

3. Strip the grounding conductor by 13 mm.
4. Lead the cable through the cable gland into the Sunny Island.
5. Insert the grounding conductor up to the stop into the **AC1 Loads/SunnyBoys PE** or **AC2 Gen/Grid PE** terminal and move the lever downward.
6. Tighten the swivel nut of the cable gland (torque: 2.6 Nm).

## 7.5.4 Connecting the Data Cables

Always proceed as follows to connect data cables.

### Procedure:

1. Push the cable feed-through plate outwards out of the enclosure.

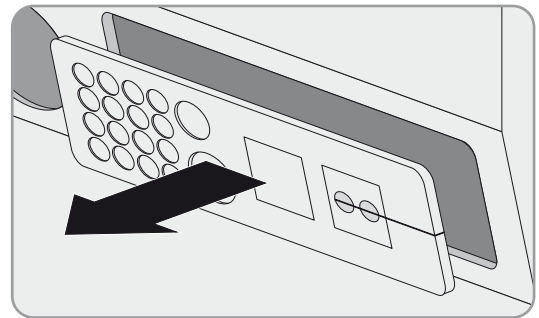

2. Retain the cable feed-through plate for later use.
3. Lead the data cable through the enclosure opening.
4. Connect the data cable.
5. When all data cables are connected, select two cable support sleeves with a suitable number of openings.
6. Open the cable support sleeves and place the cables in the cable support sleeves.

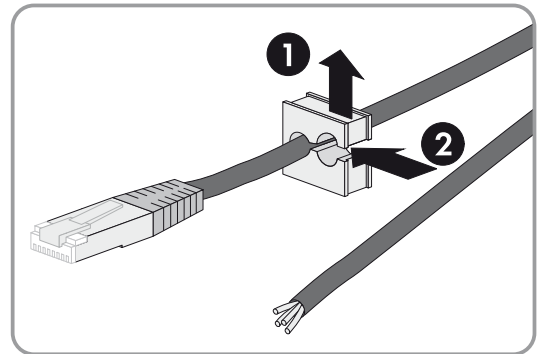

7. Open the cable feed-through plate and insert the cable support sleeves into the cable feed-through plate. Place the flat side of each cable support sleeve on the flat sides in the cable feed-through plate.

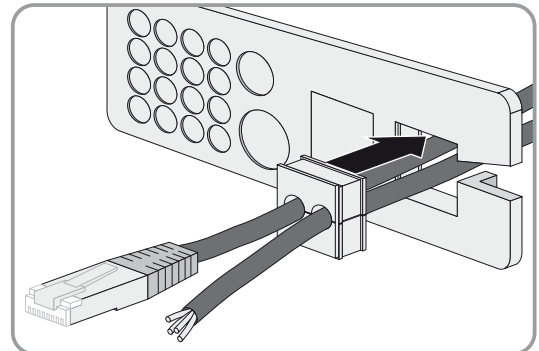

8. Hold the cables and push the cable feed-through plate to the enclosure opening of the cable feed-through plate.

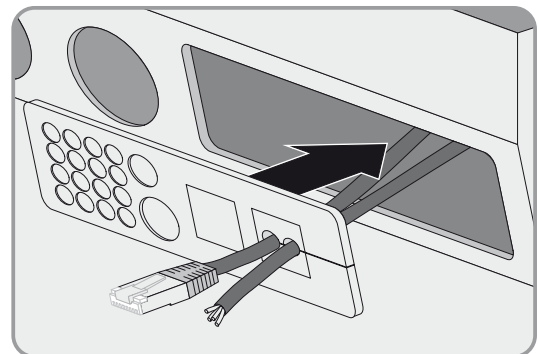

9. Hook the cable feed-through plate into the enclosure opening of the cable feed-through plate and press into the enclosure opening.



## 7.5.5 Connecting Relay 1 and Relay 2

If you are using a multifunction relay, always connect it as follows:

### **i** Switching behavior of the slaves

In case of a fault, the multifunction relays of the slaves switch less reliably than the multifunction relays of the masters.  
In case of a fault, the slaves wait for the master to confirm the fault.

### Additionally required material (not included in the scope of delivery):

- 2 bootlace ferrules

### Requirement:

- The technical requirements of the multifunction relay must be met (see Section 10 "Technical Data", page 97).
- Copper wire
- Conductor cross-section: 0.2 mm<sup>2</sup> to 2.5 mm<sup>2</sup>

### Procedure:

1. Break through a suitable location in the cable feed-through plate with a sharp object.
2. Strip the insulation from the cable and press bootlace ferrules onto the insulated conductors.
3. Lead the cable through the hole in the cable feed-through plate into the Sunny Island.

### 4. **⚠ WARNING**

#### Danger to life from electric shock due to incorrect insulation

There might be high voltage in the control cable. Faulty insulation can result in a conductive connection with other cables or components. Live components can be touched due to this connection. Touching can result in death or serious injury due to electric shock.

- Cut the silicon tube to the length of the cable in the Sunny Island.
- Pull the silicone tube over the cable.
  - The cable is double-insulated.

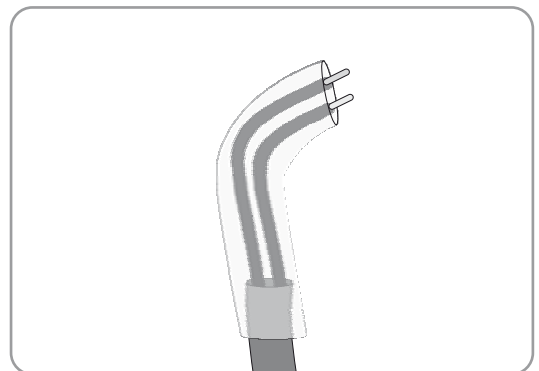

- Lead the cable into the Sunny Island making sure that it does not touch any data cables.
5. Connect the insulated conductors to the **Relay1** or **Relay2** terminals using the 3-pin terminal (torque: 0.5 Nm to 0.6 Nm):

Terminal	Explanation
NC	Closed when idle
C	Change-over contact
NO	Open when idle

### 7.5.6 Connecting BatVtg, DigIn, BatTMP and BatCur

Always connect the cables to the **BatVtg**, **DigIn**, **BatTMP** and **BatCur** as follows:

**Additionally required material (not included in the scope of delivery):**

- Bootlace ferrules

**Cable requirements:**

- Copper wire
- Conductor cross-section: 0.2 mm<sup>2</sup> to 2.5 mm<sup>2</sup>

**Procedure:**

1. Break through a suitable location in the cable feed-through plate with a sharp object.
2. Strip the cable insulation.
3. For stranded wires: press the bootlace ferrules onto the insulated conductors.
4. Lead the conductors through the hole in the cable feed-through plate into the Sunny Island.
5. Connect the conductors with the four-pole terminal (torque: 0.5 Nm to 0.6 Nm).

### 7.5.7 Connecting ExtVtg

Always connect the cable to the **ExtVtg** terminal in accordance with the following procedure.

**Additionally required material (not included in the scope of delivery):**

- Bootlace ferrules

**Cable requirements:**

- Copper wire
- Conductor cross-section: 0.2 mm<sup>2</sup> to 2.5 mm<sup>2</sup>

**Procedure:**

1. On the Sunny Island attach the M20 cable gland to the **PE/ExtVtg** enclosure opening with the counter nut (torque: 5 Nm).
2. Strip the cable insulation.
3. For stranded wires: press the bootlace ferrules onto the insulated conductors.
4. Lead the cable through the cable gland into the Sunny Island.
5. Connect the insulated conductors to the **ExtVtg** terminal using the 2-pin terminal (torque: 0.5 Nm to 0.6 Nm) (circuitry overview see Quick Reference Guide "Battery Backup Systems"):
  - Connect the line conductor to terminal **ExtVtg L**.
  - Connect the neutral conductor to terminal **ExtVtg N**.
6. Tighten the swivel nut of the cable gland (torque: 2.6 Nm).

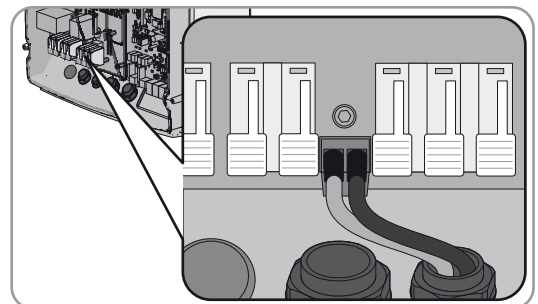
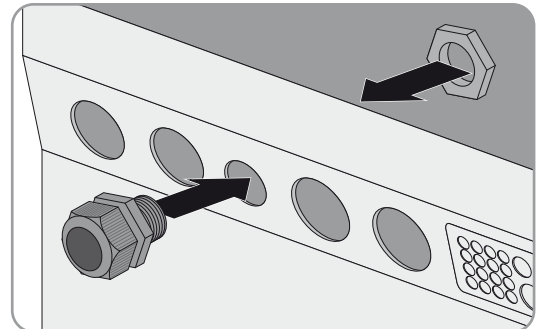

## 7.6 Checking the Wiring

Ensure that you carry out all tests relevant to the system and rectify all detected problems.

Tip: Tests can be documented directly in the tables. Cross out all tests not applicable.

### Requirement:

- All Sunny Island inverters must be disconnected from all voltage sources (see operating manual of the Sunny Island).

### Procedure:

#### Checking the Grounding

Measuring point	Test criterion	OK
Enclosure opening PE/ExtVtg	Enclosure opening is sealed with a filler plug or M20 cable gland.	<input type="checkbox"/>
	The cable diameter of the cable must be 7 mm to 14 mm for an M20 cable gland.	<input type="checkbox"/>
Conductor cross-section of the grounding conductor at the <b>AC1</b> and <b>AC2</b> terminals	If one grounding conductor is connected, the conductor cross-section must be at least 10 mm <sup>2</sup> . If two grounding conductors are connected, the cross-section of each conductor must be at least 4 mm <sup>2</sup> .	<input type="checkbox"/>
Grounding conductor connection to ground	The grounding conductor must be grounded, e.g. by connection to a grounding busbar or a foundation ground electrode.	<input type="checkbox"/>
With a TN system, neutral conductor and grounding conductor connection	Ensure by measuring that there is a conductive connection between the neutral conductor and the grounding conductor.	<input type="checkbox"/>
Grounding of the battery	Ensure that the battery is not grounded unintentionally.  If the battery has been grounded intentionally, ensure that the conductor cross-section is sufficient (see Section 7.3 "Connecting the Grounding Conductor in Systems with Grounded Battery", page 25).	<input type="checkbox"/>

#### Checking the Additional Grounding

If the battery is grounded, you must check the additional grounding on the Sunny Island.

Measuring point	Test criterion	OK
Conductor cross-section for the additional grounding	The conductor cross-section must correspond to the grounding of the battery.	<input type="checkbox"/>
Connection of additional grounding	Hexagon socket screw is screwed tight (torque: 4 Nm to 5.7 Nm).	<input type="checkbox"/>
Grounding conductor connection to ground	The grounding conductors must be grounded, e.g. by connection to a grounding busbar or a foundation ground electrode.	<input type="checkbox"/>

## Checking the DC Connection of the Sunny Island

Measuring point	Test criterion	OK
Enclosure opening for DC	In the cable gland M32, the diameter of the DC power cable must be 14 mm to 25 mm.	<input type="checkbox"/>
DC connection	Terminal lugs are pressed on firmly.	<input type="checkbox"/>
	The bolted connection for fitting terminal lugs to the DC terminal is assembled as follows: head of M8x20 screw   spring washer   fender washer   terminal lug   DC terminal.	<input type="checkbox"/>
	Terminal lugs are firmly fastened on the Sunny Island (torque: 12 Nm).	<input type="checkbox"/>
DC power cable	The maximum length of cables from the battery via the BatFuse to the Sunny Island is 10 m.	<input type="checkbox"/>
	The conductor cross-section corresponds to the minimum requirements of 50 mm <sup>2</sup> to 95 mm <sup>2</sup> (recommended conductor cross-section, see Section 7.4.1).	<input type="checkbox"/>
BatFuse	Fuse links are matched to the Sunny Island. <ul style="list-style-type: none"> <li>• SI 8.0H: 200 A</li> <li>• SI 6.0H: 160 A</li> </ul>	<input type="checkbox"/>
	The cables are attached to the BatFuse with the required torque (see BatFuse installation manual).	<input type="checkbox"/>
If installed, charge controllers and DC loads	All charge controllers and DC loads are installed in accordance with the manufacturer's data.	<input type="checkbox"/>
If installed, battery current sensor	The battery current sensor can be loaded with the maximum DC current (see technical data of the battery current sensor).	<input type="checkbox"/>

## Checking the AC1 and AC2 Terminals of the Sunny Island

Measuring point	Test criterion	OK
AC1 and AC2 enclosure openings	All enclosure openings are sealed with M25 cable glands or filler plugs.	<input type="checkbox"/>
	For an M25 cable gland, the cable diameter must be 9 mm to 18 mm.	<input type="checkbox"/>
AC1 and AC2 terminals	All contact areas are not insulated.	<input type="checkbox"/>
	All terminal levers are in the downward position.	<input type="checkbox"/>
	All cables are securely clamped.	<input type="checkbox"/>
AC power cable	The cables are sufficiently protected by circuit breakers.	<input type="checkbox"/>
	Circuit breakers with tripping characteristics B16 or C6 are installed or additional residual-current devices have been installed.	<input type="checkbox"/>
With a three-phase system, allocation of the Sunny Island inverters	The allocation of the Sunny Island inverters to the line conductors of the stand-alone grid or the Multicluster Box results in a right-hand rotating magnetic field. The master must be assigned to L1, slave 1 must be assigned to L2, slave 2 must be assigned to L3.	<input type="checkbox"/>

### Checking the Generator Connection

Measuring point	Test criterion	OK
The connection cables	The conductor cross-section is sufficient for the maximum generator current.	<input type="checkbox"/>
	The cables are sufficiently protected by circuit breakers.	<input type="checkbox"/>
With a three-phase off-grid system, allocation of the line conductors	The allocation of the Sunny Island inverters to the line conductors of the generator results in a right-hand rotating magnetic field. The master must be assigned to L1, slave 1 must be assigned to L2, slave 2 must be assigned to L3.	<input type="checkbox"/>
Grounding	The generator enclosure is grounded.	<input type="checkbox"/>

### Checking the Control and Measuring Cables

Measuring point	Test criterion	OK
Battery temperature sensor if installed	The battery temperature sensor is connected to the terminal <b>BatTmp</b> .	<input type="checkbox"/>
	The battery temperature sensor is secured in the middle of the battery bank, in the upper third of the battery cell.	<input type="checkbox"/>
If installed, the control and measuring cables of the Multicluster Box	The control and measuring cables are correctly connected (see Multicluster Box manual).	<input type="checkbox"/>
If installed, the measuring cable of the battery current sensor	The measuring cable of the battery current sensor is connected to the terminal <b>BatCur</b> with the correct polarity (see Section 7.4.9 "Connecting the Battery Current Sensor", page 41).	<input type="checkbox"/>
Control cable of the load shedding, if installed	The multifunction relay and the load-shedding contactors are correctly wired (see Section 7.4.12 "Connecting Load-Shedding Contactors", page 44).	<input type="checkbox"/>
Communication with Sunny Island Charger 50, if installed	The data cable between the Sunny Island Charger 50 and the Sunny Island is correctly connected (see Sunny Island Charger 50 manual).	<input type="checkbox"/>

### Checking the Wiring of the Communication Products

Measuring point	Test criterion	OK
Electricity supply to communication products	The plug-in power supply units are plugged in.	<input type="checkbox"/>
	The communication products are connected to an electricity supply.	<input type="checkbox"/>
Termination of the communication busses	The communication busses are connected to the first and last device in the bus.	<input type="checkbox"/>

### Checking the System Components

Measuring point	Test criterion	OK
System components	All system components are correctly connected (see the manuals of the components).	<input type="checkbox"/>
	Ensure by measuring that all system components are connected with the same ground potential.	<input type="checkbox"/>

Measuring point	Test criterion	OK
AC1 terminal in the off-grid system	The stand-alone grid or the Multicluster Box is connected to the <b>AC1 Loads/SunnyBoys</b> terminals.	<input type="checkbox"/>
AC2 terminal in the off-grid system	The generator is connected to the terminal <b>AC2 Gen/Grid</b> .	<input type="checkbox"/>
	The neutral conductor is connected to the terminal <b>AC2 Gen/Grid N</b> .	<input type="checkbox"/>

## 7.7 Closing the Sunny Island

- Use one screw for each conical spring washer. Ensure that the grooved side of the conical spring washer points to the screw head. Hint: The scope of delivery of the Sunny Island includes a spare screw and conical spring washer.
- On the Sunny Island fasten the enclosure lid following the sequence 1 to 6 using an Allen key (AF 5) (torque: 6 Nm).
  - The teeth of the conical spring washer are pushed into the enclosure lid. This ensures that the enclosure lid is grounded.

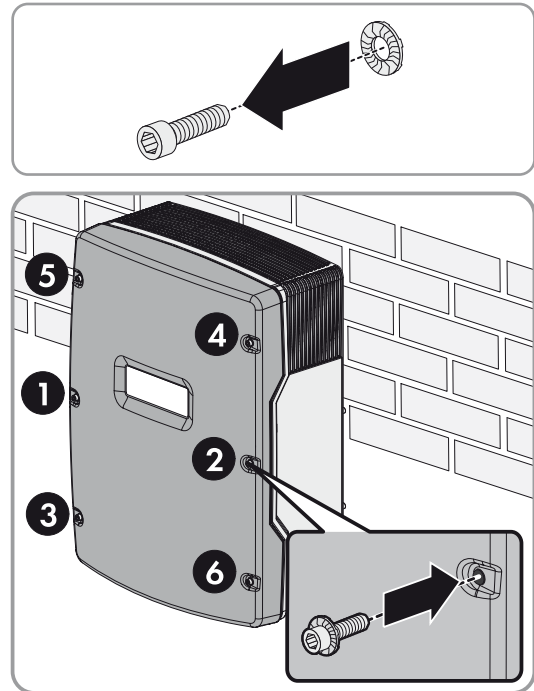

## 7.8 Inserting the Fuse Links in the Fuse Switch-Disconnecter BatFuse

- Ensure that the NH1 fuse link for the BatFuse is correct:

Sunny Island	Fuse link
SI 8.0H	200 A
SI 6.0H	160 A

- Insert the fuse link and close the BatFuse (see BatFuse documentation).

## 8 Commissioning

### 8.1 Basic Configuration

#### 8.1.1 Starting the Quick Configuration Guide

With the Quick Configuration Guide (QCG), you can configure the settings required for operation.

Step by step, the QCG queries the required settings for the system. The setting of a parameter for a cluster takes place centrally at the master. All slaves assume the configuration automatically.

##### **i** Configuration of the system using the QCG

The Sunny Island that is connected to a Sunny Remote Control when starting to configure a new system, automatically becomes the master.

- During configuration, only the master may be connected to a Sunny Remote Control.
- For a multicuster system, each cluster must be configured individually at the master.

##### Requirements:

- All circuit breakers in the AC distribution board must be open.
- All Sunny Island inverters must be closed.
- All Sunny Island inverters must be switched off.

##### Procedure:

1. Quickly connect the load-break switch of the BatFuse and close the BatFuse (see the installation manual of the BatFuse).
2. Start the Sunny Island:
  - For single systems, press the activation button on the Sunny Island.
  - For a cluster, press and hold down the activation button on the master until an acoustic signal sounds. As a result, all Sunny Island inverters in the cluster are switched on.

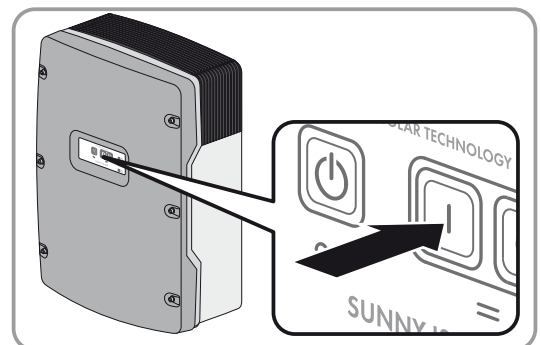

3. When the Sunny Remote Control shows **<Init System>**⏏, press and hold the button on the Sunny Remote Control (for the control concept of the Sunny Remote Control see Sunny Island operating manual).

- A signal sounds three times and the Sunny Remote Control displays the QCG.

- ✘** The Sunny Remote Control does not display the QCG?

You have either pressed the button too late or not long enough.

- Press the off button.
- Repeat steps 2 and 3.

```

Boot          xxxxxxx-xx
              <Init System>⏏
xx.xx.xxxx   xx!xx!xx
  
```

```

Select option
001#01 [00#000000]
        StartMenu
        Start System⏏
  
```

## 8.1.2 Performing Basic Configuration of the Sunny Island

### Requirement:

- The Sunny Remote Control must be connected to the master.
- All Sunny Island inverters must be switched on, but not in operation (for switching on the Sunny Island see Sunny Island operating manual).
- The Quick Configuration Guide (QCG) is started.

### Procedure:

1. Turn the button on the Sunny Remote Control to the right and select **New System**.

```
Select option
001#01  [00#000000]
          StartMenu
          New System!
```

2. Press the button.
3. Turn the button to the right until **Y** flashes and press the button. This confirms your selection of **New System**.
4. Set the parameters of the QCG (carry out basic configuration in accordance with the installed system, see quick reference guide of the installed system).

## 8.1.3 Setting Sunny Island Charger for Charge Controller/Sunny Island Charger in Off-Grid Systems

### Requirement:

- For systems with a maximum of four Sunny Island Charger devices, all Sunny Island Charger devices must be connected to the master via a communication bus.

### Procedure:

1. Switch to expert mode on the Sunny Remote Control (see Sunny Island operating manual).
2. Select the parameter **250.29 ChrgCtlOp** and set as follows:

Value	Explanation
Auto	System with AC sources (e.g. PV inverter)
SMA	System with Sunny Island Charger and without AC sources A maximum of four Sunny Island Charger devices is installed.
NoFrq	System with charge controllers and without AC sources The charge controllers are not Sunny Island Charger devices or the number is greater than four Sunny Island Charger.



### 8.1.4 Commissioning the Battery Current Sensor in Off-Grid Systems

To operate the battery current sensor, you must set the type of the battery current sensor and start the adjustments of the battery current sensor.

The Sunny Island distinguishes between battery current sensors of the types 50 mV and 60 mV. The types reflect the amplification factor of the battery current sensor. The amplification factors are given in amperes per 50 mV or in amperes per 60 mV, e.g. 400 A/60 mV.

#### Procedure:

1. Switch off the Sunny Island and quickly open the BatFuse load-break switch.

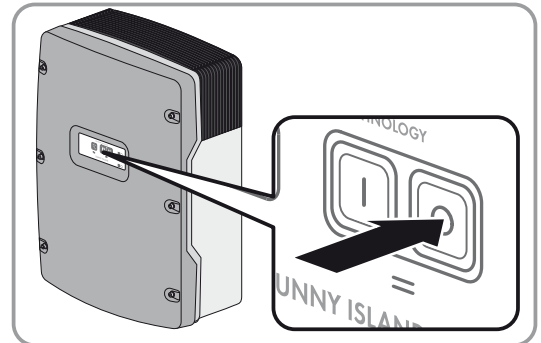

2. Short-circuit the measuring cable at the battery current sensor. Connect the BatCur- and BatCur+ measuring conductors to the terminal for BatCur+.

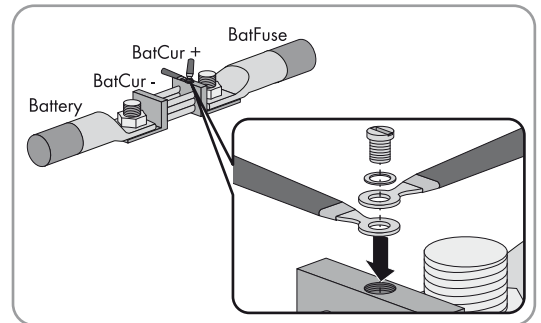

3. Close the BatFuse load-break switch quickly and switch the Sunny Island on.

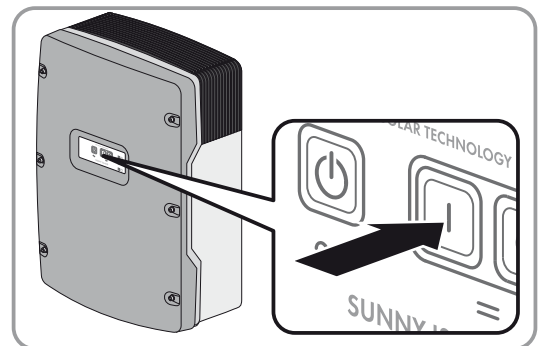

4. Switch to installer mode on the Sunny Remote Control (see Sunny Island operating manual).
5. Select the parameter **225.01 BatCurSnsTyp** and set to the type of the battery current sensor used.
6. For a 60 mV model, select the **225.02 BatCurGain60** parameter and set it according to gain the factor of the battery current sensor.
7. For a 50 mV model, select the **225.03 BatCurGain50** parameter and set it according to the gain factor of the battery current sensor.
8. Select the parameter **225.04 BatCurAutoCal** and set to **Start**.
  - The Sunny Island starts the adjustment.

9. After ten seconds, select the **120.06 TotBatCur** parameter and read off the value.

☑ The parameter value is between 0 A and 1 A.

✘ The parameter value is not between 0 A and 1 A.

The measuring cable is not correctly connected or short-circuited.

- Check whether the measuring cable is correctly connected and short-circuited.
- Repeat steps 8 and 9.

10. Switch off the Sunny Island and open the BatFuse load-break switch quickly.

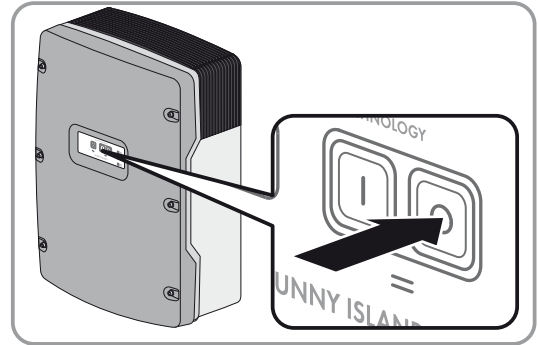

11. Connect BatCur+ measuring conductor on the side for connecting the BatFuse.

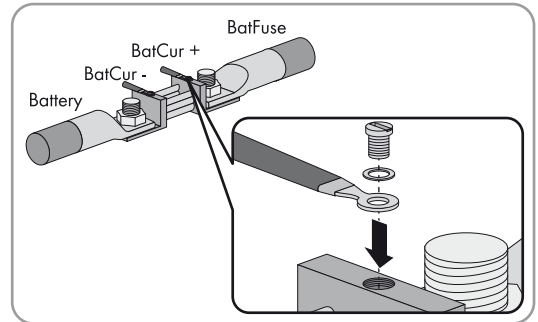

12. Connect the BatCur- measuring conductor on the side for connecting the battery.

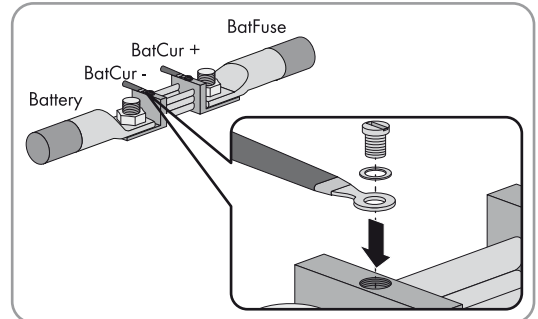

13. Close the BatFuse load-break switch quickly and switch on the Sunny Island.

### 8.1.5 Setting the Functions of the Multifunction Relays

Note the function of the multifunction relays in the following table during the electrical connection (see Section 7.4, page 27). Alternatively, you can use the parameter listing (parameter listing in the **240# Relay** menu, see Sunny Island operating manual). The multifunction relays of the master are preset in battery backup systems and cannot be changed.

**Table for configuration:**

Multifunction relay	Value	Function/output
Relay 1 of the Sunny Island/master, parameter <b>241.01 Rly1Op</b>		
Relay 2 of the Sunny Island/master, parameter <b>241.01 Rly1Op</b>		
Relay 1 of slave 1, parameter <b>244.01 Rly1OpSlv1</b>		
Relay 2 of slave 1, parameter <b>244.02 Rly2OpSlv1</b>		
Relay 1 of slave 2, parameter <b>245.01 Rly1OpSlv2</b>		
Relay 2 of slave 2, parameter <b>244.01 Rly2OpSlv2</b>		

**Procedure:**

1. Switch to installer mode on the Sunny Remote Control (see Sunny Island operating manual).
2. Set the parameter for the multifunction relay functions as shown in the table above.

## 8.2 Battery Management

### 8.2.1 Adjusting the Battery Management to the Battery

For further information on battery management and on load procedures of the Sunny Island, see Technical Information "Battery Management" on the CD supplied.

#### NOTICE

##### Damage to the battery due to incorrect settings

Settings of the parameters in the menu **220# Battery** influence the charging behavior of the Sunny Island. Incorrect settings lead to premature aging of the battery.

- Ensure that the values recommended by the battery manufacturer are set for the battery (refer to the technical data of the battery in the manufacturer documentation).

#### Procedure:

1. Switch to expert mode on the Sunny Remote Control (see Sunny Island operating manual).
2. Select the parameter **222.01 BatChrgCurMax** and set it to the maximum battery charging current recommended by the battery manufacturer.
3. Set the parameters for boost charge.
  - Select the parameter **222.02 AptmBoost** and set to the boost-charge absorption time recommended by the battery manufacturer.
  - Select the parameter **222.07 ChrgVtgBoost** and set it to the cell-voltage setpoint recommended by the battery manufacturer for boost charge.
4. Set the parameters for full charge.
  - Select the parameter **222.03 AptmFul** and set to the full-charge absorption time recommended by the battery manufacturer.
  - Select the parameter **222.05 CycTmFul** and set to the full-charge cycle time recommended by the battery manufacturer.
  - Select the parameter **222.08 ChrgVtgFul** and set it to the cell-voltage setpoint recommended by the battery manufacturer for full charge.
5. Set the parameters for equalization charge.
  - Select the parameter **222.04 AptmEqu** and set it to the equalization charge absorption time recommended by the battery manufacturer.
  - Select the parameter **222.06 CycTmEqu** and set it to the equalization charge cycle time recommended by the battery manufacturer.
  - Select the parameter **222.09 ChrgVtgEqu** and set it to the cell-voltage setpoint recommended by the battery manufacturer for equalization charge.

## 8.2.2 Changing the Battery Usage through Battery Backup Systems without Increased Self-Consumption

### **i** Adjusting the default values

The parameters for battery usage are set automatically to reasonable values during basic configuration for the respective system. The parameter values can be adjusted if there are special requirements for the system or the battery.

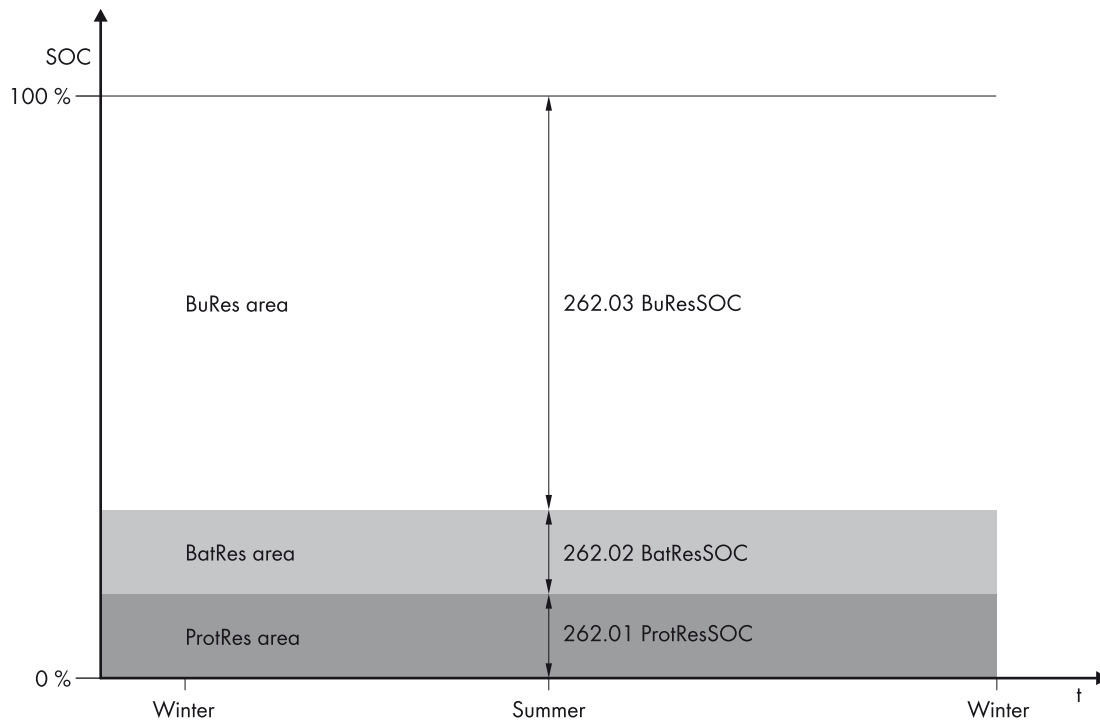

Figure 19: Ranges of the state of charge of the battery depending on the season (example)

Range	Parameter and explanation of the range	Behavior of the Sunny Island
BuRes	262.03 BUResSOC Range for the battery backup system function	The Sunny Island uses this range for supplying the battery backup grid when the utility grid fails. When the utility grid is available again, the battery is charged by the Sunny Island with nominal power from the utility grid.
BatRes	262.02 BatResSOC Range for protection against deep discharge This range can only be reached when the utility grid fails.	The Sunny Island switches into standby mode. The Sunny Island starts up every two hours and tries charging the battery with PV energy. If the battery cannot be charged, the Sunny Island switches back to standby mode.  When the utility grid is available again, the battery is charged by the Sunny Island with nominal power from the utility grid.
ProtRes	262.01 ProtResSOC Range for protection during deep discharge This range can only be reached when the utility grid fails.	The Sunny Island switches off in order to protect the battery when this range is reached. When the utility grid is available again, the system must be charged manually ("Charging the Battery after Auto Power Off" see Sunny Island operating manual).

The following ranges result from the parameter default values:

Range	Lead-acid battery	Lithium-ion battery
BuRes	15% to 100%	13% to 100%
BatRes	10% to 15%	3% to 13%
ProtRes	0% to 10%	0% to 3%

**Procedure:**

1. Switch to expert mode on the Sunny Remote Control (see Sunny Island operating manual).
2. Set the following parameters for the increased self-consumption:

Parameter	Value
261.01 SlfCsmpIncEna	<b>Disable</b>
262.01 ProtResSOC	Range for protection during deep discharge in percent of the battery capacity
262.02 BatResSOC	Range for protection against deep discharge in percent of battery capacity
262.03 BUResSOC	Range for the battery backup system function If all ranges combined do not amount to 100%, the BuRes range will be increased automatically.
261.03 Saisonenable	<b>No</b>

## 8.2.3 Battery Usage through Systems for Increased Self-Consumption

### 8.2.3.1 Seasonal Adjustment of the Battery Usage

The options for increased self-consumption greatly depend on the battery and the PV energy availability. In order to use the battery optimally, you can adjust the depth of discharge of the battery to the application.

In many regions, the PV energy available largely depends on the season and the hours of sunshine. The Sunny Island cannot charge the battery entirely on short days with few hours of sunlight. Lead-acid batteries in particular age faster due to low charging over a long period. Therefore, it is better if the battery is not discharged too much by the Sunny Island on short days. On short days there is a lack of PV energy necessary for charging the battery. The Sunny Island can usually charge the battery entirely on long days with many hours of sunlight. It is better to use as much of the battery capacity as possible for optimizing the self-consumption during these time periods.

The discharge behavior can be adjusted to the location and time by the Sunny Island. You can activate the seasonal adjustment for this (**261.03 Saisonenable**). The Sunny Island only uses a small portion of battery capacity for increased self-consumption on short days when adjustment is activated. The Sunny Island uses a large portion of the battery capacity for the increased self-consumption on long days. The seasonal adjustment prolongs the electrical endurance of the battery in regions where the available PV energy heavily depends on the season.

### 8.2.3.2 Changing the Battery Usage through Systems for Increased Self-Consumption without a Battery Backup Grid

**i** **Adjusting the default values**

The parameters for battery usage are set automatically to reasonable values during basic configuration for the respective system. The parameter values can be adjusted if there are special requirements for the system or the battery.

In systems for increased self-consumption, one range can be adjusted seasonally:

- Increased self-consumption range (SlfCsmP)

You determine the battery capacity percentage that should be used for increased self-consumption on the shortest day of the year.

The longer the days become, the more the SlfCsmP range increases automatically and the range for protection against deep discharge (BatRes) decreases. The range for increased self-consumption reaches its maximum on the longest day:

$$SlfCsmP_{max} = 100\% - 262.04 PVResSOC - 262.02 BatResSOC - 262.01 ProtResSOC$$

This results in the seasonal course of the ranges.

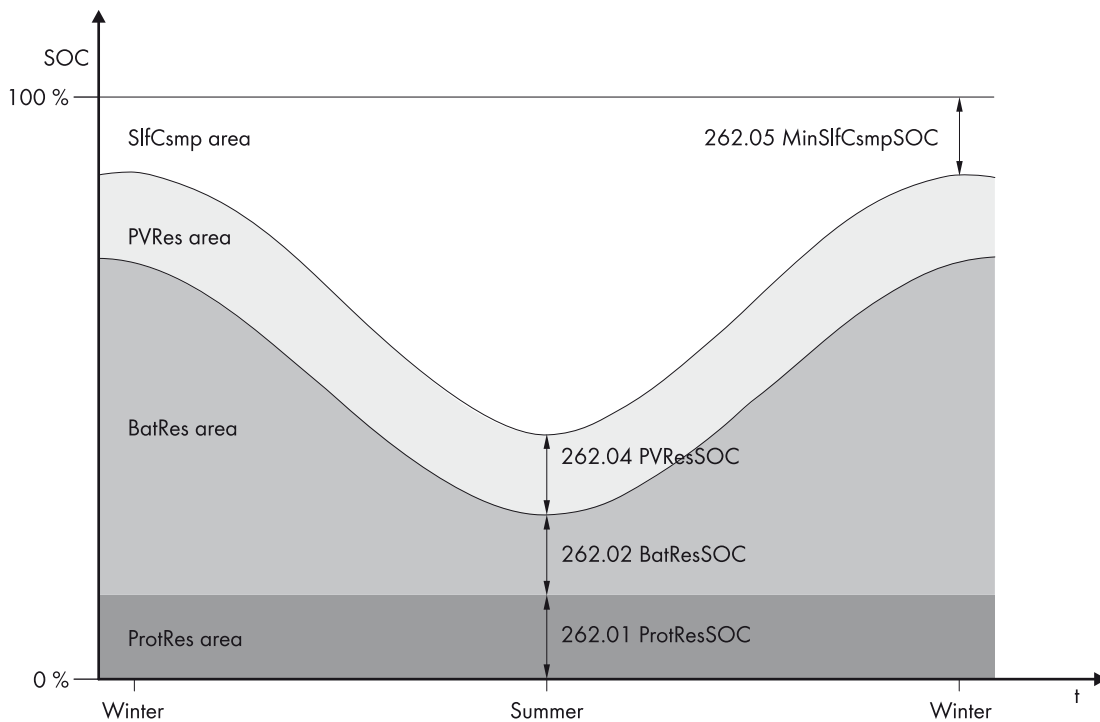

Figure 20: Ranges of the state of charge of the battery depending on the season (example)

Range	Parameter and explanation of the range	Behavior of the Sunny Island
SlfCsmP	<p>262.05 MinSlfCsmPSOC</p> <p>Range for the increased self-consumption</p> <p>The value 262.05 MinSlfCsmPSOC applies to the shortest day of the year when seasonally adjusted (see Section 8.2.3.1, page 70). If seasonal adjustment is deactivated, only the value of parameter 262.05 MinSlfCsmPSOC is used and the BatRes range increased respectively.</p>	The Sunny Island uses the battery for increased self-consumption.

Range	Parameter and explanation of the range	Behavior of the Sunny Island
PVRes	262.04 PVResSOC Range for maintaining the state of charge of the battery The range size is consistent year-round.	Excess PV energy is used for conserving the battery charge. The Sunny Island switches into silent mode if no excess PV energy is available. When the state of charge reaches the BatRes range limit, the Sunny Island charges the battery up to half of the PVRes range from the utility grid. The Sunny Island charges the battery with maximum efficiency at 25% of the nominal power of the Sunny Island.
BatRes	262.02 BatResSOC Range for protection against deep discharge This range can only be reached when the utility grid fails. The value of parameter 262.02 BatResSOC applies to the longest day of the year when seasonally adjusted (see Section 8.2.3.1, page 70). When the seasonal adjustment is deactivated, the BatRes range will be increased respectively.	If a utility grid is available, the Sunny Island charges the battery using nominal power from the utility grid.
ProtRes	262.01 ProtResSOC Range for protection during deep discharge This range can only be reached when the utility grid fails.	The Sunny Island switches off in order to protect the battery when this range is reached. When the utility grid is available again, the system must be charged manually ("Charging the Battery after Auto Power Off" see Sunny Island operating manual).

The following ranges result from the parameter default values:

Range	Lead-acid battery		Lithium-ion battery	
	Shortest day*	Longest day**	Shortest day*	Longest day**
MinSlfCsm	65% to 100%	45% to 100%	30% to 100%	10% to 100%
PVRes	60% to 65%	40% to 45%	25% to 30%	5% to 10%
BatRes	10% to 60%	10% to 40%	3% to 25%	3% to 5%
ProtRes	0% to 10%	0% to 10%	0% to 3%	0% to 3%

\* December 21st (northern hemisphere) or June 21st (southern hemisphere)

\*\* June 21st (northern hemisphere) or December 21st (southern hemisphere)



The following ranges result from deactivating the seasonal adjustment with the default values of the parameters:

Range	Lead-acid battery	Lithium-ion battery
MinSlfCsmpl	65% to 100%	30% to 100%
PVRes	60% to 65%	25% to 30%
BatRes	10% to 60%	3% to 25%
ProtRes	0% to 10%	0% to 3%

**Requirement:**

- The system is not a battery backup system

**Procedure:**

1. Switch to expert mode on the Sunny Remote Control (see Sunny Island operating manual).
2. Set the following parameters for the battery usage:

Parameter	Value
261.01 SlfCsmplncEna	Enable
262.01 ProtResSOC	Range for protection during deep discharge in percent of the battery capacity
262.02 BatResSOC	Range for the protection against deep discharge on the longest day of the year in percent of the battery capacity The range remains consistent year-round when seasonal adjustment is deactivated.
262.04 PVResSOC	Range for maintaining the state of charge of the battery in percent of the battery capacity
262.05 MinSlfCsmplSOC	Range for optimizing the self-consumption on the shortest day of the year in percent of the battery capacity When seasonal adjustment is deactivated this value is used year-round for the increased self-consumption.
261.02 SlfCsmplPosSel	<b>North</b> for northern hemisphere or <b>South</b> for southern hemisphere
261.03 Saisonenable	<b>No</b> for no seasonal adjustment or <b>Yes</b> for seasonal adjustment

- ✘ A parameter cannot be adjusted?

All ranges combined result in a value greater than 100%.

- Ensure that all ranges have been set correctly.

### 8.2.3.3 Changing the Battery Usage through Battery Backup Systems with Increased Self-Consumption

#### **i** Adjusting the default values

The parameters for battery usage are set automatically to reasonable values during basic configuration for the respective system. The parameter values can be adjusted if there are special requirements for the system or the battery.

Two ranges can be adjusted seasonally in battery backup systems with increased self-consumption:

- Range for increased self-consumption (MinSlfCsmP)

You determine the battery capacity percentage that should be used for increased self-consumption on the shortest day of the year.

- Range for the battery backup system function (BURes)

You select the battery capacity percentage that should be used for the battery backup function on the longest day.

The longer the days become, the more the SlfCsmP range automatically increases and the BURes range decreases. The range for increased self-consumption reaches its maximum on the longest day:

$$\text{SlfCsmP}_{\text{max}} = 100\% - 262.04 \text{ PVResSOC} - 262.03 \text{ BUResSOC} - 262.02 \text{ BatResSOC} - 262.01 \text{ ProtResSOC}$$

This results in the seasonal course of the ranges.

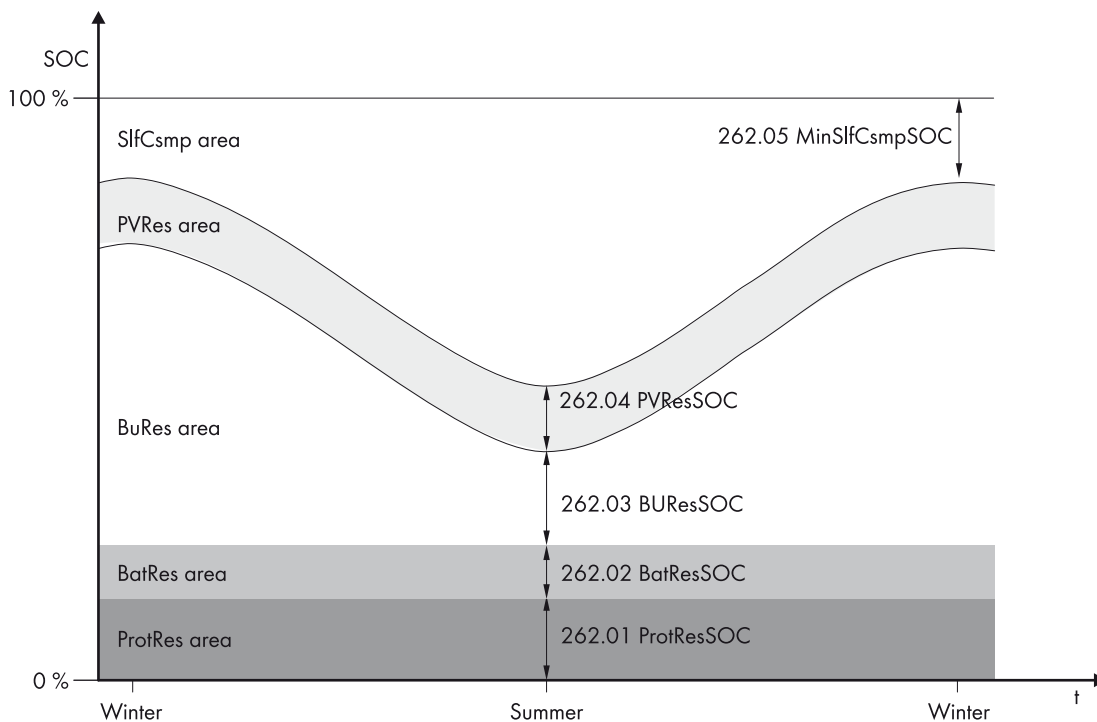

Figure 21: Ranges of the state of charge of the battery depending on the season (example)

Range	Parameter and explanation of the value	Behavior of the Sunny Island
SlfCsmP	262.05 MinSlfCsmPSOC Range for the increased self-consumption The value of 262.05 MinSlfCsmPSOC applies to the shortest day of the year with seasonal adjustment (see Section 8.2.3.1, page 70). If seasonal adjustment is deactivated, only the value of parameter 262.05 MinSlfCsmPSOC is used and the BURes range increased respectively.	The Sunny Island uses the battery for increased self-consumption.

Range	Parameter and explanation of the value	Behavior of the Sunny Island
PVRes	262.04 PVResSOC Range for maintaining the state of charge of the battery The range size is consistent year-round.	Excess PV energy is used for conserving the battery charge. The Sunny Island switches into silent mode if no excess PV energy is available. When the state of charge reaches the BatRes range limit, the Sunny Island charges the battery up to half of the PVRes range from the utility grid. The Sunny Island charges the battery with maximum efficiency at 25% of the nominal power of the Sunny Island.
BURes	262.03 BUResSOC Range for the battery backup system function With seasonal adjustment (see Section 8.2.3.1, page 70) the value of 262.03 BUResSOC applies to the longest day of the year. When the seasonal adjustment is deactivated, only the minimum range is being used and the SlfCsmpl increased respectively.	The Sunny Island uses this range for supplying the battery backup grid when the utility grid fails. When the utility grid is available again, the battery is charged by the Sunny Island with nominal power from the utility grid.
BatRes	262.02 BatResSOC Range for protection against deep discharge This range can only be reached when the utility grid fails.	The Sunny Island switches into standby mode. The Sunny Island starts up every two hours and tries charging the battery with PV energy. If the battery cannot be charged, the Sunny Island switches back to standby mode. When the utility grid is available, the Sunny Island charges the battery with nominal power from the utility grid.
ProtRes	262.01 ProtResSOC Range for protection during deep discharge This range can only be reached when the utility grid fails.	The Sunny Island switches off in order to protect the battery when this range is reached. When the utility grid is available again, the system must be charged manually ("Charging the Battery after Auto Power Off" see Sunny Island operating manual).

The following ranges result from the parameter default values:

Range	Lead-acid battery		Lithium-ion battery	
	Shortest day*	Longest day**	Shortest day*	Longest day**
SlfCsmP	65% to 100%	45% to 100%	30% to 100%	28% to 100%
PVRes	60% to 65%	40% to 45%	25% to 30%	23% to 28%
BURes	15% to 60%	15% to 40%	13% to 25%	13% to 23%
BatRes	10% to 15%	10% to 15%	3% to 13%	3% to 13%
ProtRes	0% to 10%	0% to 10%	0% to 3%	0% to 3%

\* December 21st (northern hemisphere) or June 21st (southern hemisphere)

\*\* June 21st (northern hemisphere) or December 21st (southern hemisphere)

The following ranges result from deactivating the seasonal adjustment with the default values of the parameters:

Range	Lead-acid battery	Lithium-ion battery
SlfCsmP	65% to 100%	30% to 100%
PVRes	60% to 65%	25% to 30%
BURes	15% to 60%	13% to 25%
BatRes	10% to 15%	3% to 13%
ProtRes	0% to 10%	0% to 3%

#### Procedure:

1. Switch to expert mode on the Sunny Remote Control (see Sunny Island operating manual).
2. Set the following parameters for the increased self-consumption:

Parameter	Value
261.01 SlfCsmPlncEna	Enable
262.01 ProtResSOC	Range for protection during deep discharge in percent of the battery capacity
262.02 BatResSOC	Range for protection against deep discharge in percent of battery capacity
262.03 BUResSOC	Range for the battery backup function on the longest day of the year in percent of the battery capacity The range remains consistent year-round when seasonal adjustment is deactivated.
262.04 PVResSOC	Range for maintaining the state of charge in percent of the nominal capacity
262.05 MinSlfCsmPSOC	Range for increased self-consumption on the shortest day of the year in percent of the battery capacity When seasonal adjustment is deactivated this value is used year-round for the increased self-consumption.
261.02 SlfCsmPosSel	<b>North</b> for northern hemisphere or <b>South</b> for southern hemisphere
261.03 Saisonenable	<b>No</b> for no seasonal adjustment or <b>Yes</b> for seasonal adjustment

✘ A parameter cannot be adjusted?

All ranges combined result in a value greater than 100%.

- Ensure that all ranges have been set correctly.

## 8.2.4 Changing the Battery Protection Mode in Off-Grid Systems

### **i** Battery Protection mode for lithium-ion batteries cannot be changed

You can only change the Battery Protection mode if you are using lead-acid batteries. When using lithium-ion batteries, the Battery Protection mode cannot be changed.

#### **Function of the Battery Protection mode:**

Battery Protection mode protects the battery.

If the state of charge of the battery falls below a defined threshold, Battery Protection mode is activated. In Battery Protection mode, the Sunny Island switches to standby mode or switches itself off. The Battery Protection mode has three levels. One SOC threshold can be set for each level. Levels 1 and 2 of the Battery Protection mode have specific start and end times and are therefore dependent on the time of day (see Section 9.3 "Setting Time-Dependent Functions", page 95).

- Level 1

If the state of charge drops below the SOC threshold for level 1, the Sunny Island switches to standby between the start time and the end time. This way you can specify preferred times for the Sunny Island to be switched off if an energy deficit occurs.

- Level 2

If the state of charge drops below the threshold for level 2, the Sunny Island switches to standby. Use the start time and end time to define the time window in which no energy is anticipated from AC sources. Outside this time window, the Sunny Island starts up every two hours to charge the battery. If no energy is available to charge the battery, the Sunny Island remains on standby.

This means that e.g. in stand-alone grids with PV inverters, you can specify that the Sunny Island does not start up at night and does not use energy from the battery.

- Level 3

If the state of charge drops below the threshold for level 3, the Sunny Island switches itself off. This protects the battery against deep discharge and severe damage. To charge the battery again, the Sunny Island must be switched on and started manually.

At all three levels, the Sunny Island will only switch to standby mode or switch itself off if no charging current has flowed in the battery at least five minutes.

#### **Recharging the battery with an external energy source:**

In levels 1 and 2 of Battery Protection mode, you can charge the battery at any time with an external energy source. If a voltage is present at the **AC2** terminal, the Sunny Island exits standby mode.

If the Sunny Island has switched itself off in level 3 of battery protection mode, you must charge the battery in emergency charge mode (see Sunny Island operating manual).

#### **Time settings:**

The start and end time can be configured for Battery Protection mode levels 1 and 2.

If the state of charge drops below the SOC threshold for level 1, the Sunny Island switches to standby between the start time and the end time.

If the state of charge drops below the SOC threshold for level 2, the Sunny Island switches to standby between the start time and the end time. The Sunny Island tries charging the battery in the remaining time.

#### **Requirement:**

- In a cluster, the Sunny Remote Control must be connected to the master.

**Procedure:**

1. Switch to expert mode on the Sunny Remote Control (see Sunny Island operating manual).
2. To change Battery Protection mode 1, set the desired times and SOC thresholds as follows:
  - Select the parameter **223.01 BatPro1TmStr** and set to the desired start time.
  - Select the parameter **223.02 BatPro1TmStp** and set to the desired end time.
  - Select the parameter **223.05 BatPro1Soc** and set to the desired SOC threshold.
3. To change Battery Protection mode 2, set the desired times and SOC thresholds as follows:
  - Select the parameter **223.03 BatPro2TmStr** and set to the desired start time.
  - Select the parameter **223.04 BatPro2TmStp** and set to the desired end time.
  - Select the parameter **223.06 BatPro2Soc** and set to the desired SOC threshold.
4. To change Battery Protection mode 3, select the parameter **223.07 BatPro3Soc** and set to the desired SOC threshold.

### 8.2.5 Configuring the Resistance of the Battery Cable

You can optimize the battery management if you set the resistance of the battery cable in expert mode.

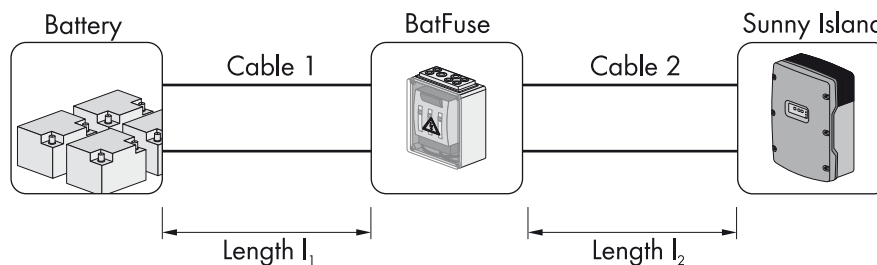

Figure 22: Designation of the cable

The resistance of the battery cable is composed of the resistance of cable 1, the BatFuse, and the resistance of cable 2.

**Requirement:**

- In a cluster, the Sunny Remote Control must be connected to the master.

**Procedure:**

1. Calculate the individual cable resistances. For this purpose, use the following formula:

$$R_{Cu}(l,A) = \rho \frac{l}{A}$$

$R_{Cu}(l,A)$  = resistance of the cable

$\rho$  = specific resistance of copper ( $\rho = 0.018 \frac{\Omega \text{ mm}^2}{\text{m}}$ )

$l$  = total length of the conductor (outward conductor + return conductor = twice the cable length) in m

$A$  = conductor cross-section in  $\text{mm}^2$

2. Calculate the total resistance of the battery cable. For this purpose, use the following formula:

$$R_{\text{BatRes}} = R_{\text{Cable 1}} + R_{\text{BatFuse}} + R_{\text{Cable 2}}$$

$R_{\text{BatRes}}$  = total resistance of the battery cable

$R_{\text{Cable 1}}$  = calculated resistance of cable 1

$R_{\text{Cable 2}}$  = calculated resistance of cable 2

$R_{\text{BatFuse}}$  = calculated resistance of BatFuse =  $2 \text{ m} \Omega$

3. Switch to expert mode on the Sunny Remote Control (see Sunny Island operating manual).
4. Select the parameter **221.06 BatWirRes** and set to the resistance of the battery cable.

## 8.2.6 Setting the Control of the Battery Room Fan

1. Switch to installer mode on the Sunny Remote Control (see Sunny Island operating manual).
2. Select the **221.07 BatFanTmpStr** parameter and set it to the battery temperature at which the fan is to be switched on.
3. Ensure that the multifunction relay used for control is set to **BatFan** or **MccBatFan** (see Section 8.1.5 "Setting the Functions of the Multifunction Relays", page 67).
4. Ensure that the battery room is sufficiently ventilated in the case of malfunctions – for example, failure of the multifunction relay.

## 8.3 Energy Management

### 8.3.1 Setting Load Shedding in a Multicluster System

The load contactor in the Multicluster Box is a load-shedding contactor and is controlled depending on the state of charge of the batteries.

#### Significance of the SOC thresholds:

When the state of charge of a battery reaches the lower SOC threshold, the load-shedding contactor is opened. The state of charge of the battery of the main cluster and the states of charge of the batteries of the extension clusters are evaluated. The load-shedding contactor disconnects the loads from the stand-alone grid. When the state of charge of all batteries reaches the upper SOC threshold during recharging, the load-shedding contactor closes. The load-shedding contactor connects the loads to the stand-alone grid.

#### Requirement:

- The Sunny Remote Control must be connected to the master of the main cluster.

#### Procedure:

1. Switch to installer mode on the Sunny Remote Control (see Sunny Island operating manual).
2. Select the **242.01 Lod1SocTm1Str** parameter and set it to the lower SOC threshold.
3. Select the **242.02 Lod1SocTm1Stp** parameter and set it to the upper SOC threshold. The upper SOC threshold must be at least 10 percentage points above the lower SOC threshold.
4. Set the **242.05 Lod1Tm1Str** and **242.06 Lod1Tm2Str** parameters to the same value, e.g. both to **00:00:00**. This switches off time-dependent load shedding.
5. If the off-grid system is a multicluster system, ensure that the parameter of the multifunction relay is set to **MccAutoLod** (see Section 8.1.5 "Setting the Functions of the Multifunction Relays", page 67).

### 8.3.2 Setting 1-Level Load Shedding

One multifunction relay controls the load-shedding contactor depending on the state of charge of the battery.

#### Significance of the SOC thresholds:

When the state of charge of the battery reaches the lower SOC threshold, the multifunction relay opens the connected load-shedding contactor. The load-shedding contactor disconnects the loads from the stand-alone grid. When the state of charge of the battery reaches the upper SOC threshold during recharging, the multifunction relay closes the connected load-shedding contactor. The load-shedding contactor connects the loads to the stand-alone grid.

#### Requirement:

- In a cluster, the Sunny Remote Control must be connected to the master.

#### Procedure:

1. Switch to installer mode on the Sunny Remote Control (see Sunny Island operating manual).
2. Select the **242.01 Lod1SocTm1Str** parameter and set it to the lower SOC threshold.
3. Select the **242.02 Lod1SocTm1Stp** parameter and set it to the upper SOC threshold. The upper SOC threshold must be at least 10 percentage points above the lower SOC threshold.
4. Set the **242.05 Lod1Tm1Str** and **242.06 Lod1Tm2Str** parameters to the same value, e.g. both to **00:00:00**. This switches off time-dependent load shedding.
5. If the loads are only to be reconnected when the set SOC threshold is reached, ensure that the parameter of the multifunction relay has been set to **AutoLod1Soc** (see Section 8.1.5 "Setting the Functions of the Multifunction Relays", page 67).
6. If the loads are to be supplied by an external energy source during recharging of the battery, ensure the following:
  - Ensure that the parameter of the multifunction relay is set to **AutoLodExt** (see Section 8.1.5 "Setting the Functions of the Multifunction Relays", page 67).
  - Ensure that the external energy source can supply the loads with sufficient power.
7. If the off-grid system is a multicenter system, ensure that the parameter of the multifunction relay is set to **MccAutoLod** (see Section 8.1.5 "Setting the Functions of the Multifunction Relays", page 67).

### 8.3.3 Setting 2-Level Load Shedding

Two multifunction relays control two load-shedding contactors depending on the state of charge of the battery.

#### Significance of the SOC thresholds:

Two lower and two upper SOC thresholds each are available for controlling the load-shedding contactors. The load-shedding contactors disconnect the loads from the utility grid if the states of charge are as follows:

- When the state of charge of the battery reaches the first lower SOC threshold, the multifunction relay opens the connected load-shedding contactor for the first level of load shedding. The load-shedding contactor disconnects those loads from the utility grid that are to be disconnected for the first level.
- When the state of charge of the battery reaches the second lower SOC threshold, the multifunction relay opens the connected load-shedding contactor for the second level of load shedding. The load-shedding contactor disconnects the remaining loads from the utility grid.
- When the state of charge of the battery reaches the second upper SOC threshold during recharging, the multifunction relay closes the connected load-shedding contactor for the second level of load shedding. The load-shedding contactor connects those loads to the utility grid that were disconnected for the second level.
- When the state of charge of the battery reaches the first upper SOC threshold during recharging, the multifunction relay closes the connected load-shedding contactor for the first level of load shedding. The load-shedding contactor connects those loads to the utility grid that were disconnected for the first level. All loads are connected to the utility grid.



**Requirement:**

- In a cluster, the Sunny Remote Control must be connected to the master.

**Procedure:**

1. Switch to installer mode on the Sunny Remote Control (see Sunny Island operating manual).
2. Setting the first level of load shedding:
  - Select the **242.01 Lod1SocTm1Str** parameter and set it to the lower SOC threshold.
  - Select the **242.02 Lod1SocTm1Stp** parameter and set it to the upper SOC threshold.
  - Set the **242.05 Lod1Tm1Str** and **242.06 Lod1Tm2Str** parameters to the same value, e.g. both to **000000**. This switches off time-dependent load shedding.
  - Ensure that the parameter of the multifunction relay is set to **AutoLod1Soc** (see Section 8.1.5 "Setting the Functions of the Multifunction Relays", page 67).
3. Setting the second level of load shedding:
  - Select the **242.07 Lod2SocTm1Str** parameter and set it to the lower SOC threshold.
  - Select the **242.08 Lod2SocTm1Stp** parameter and set it to the upper SOC threshold.
  - Set the **242.11 Lod2Tm1Str** and **242.12 Lod2Tm2Str** parameters to the same value, e.g. to **000000**. This switches off time-dependent load shedding.
  - Ensure that the parameter of the multifunction relay is set to **AutoLod2Soc** (see Section 8.1.5 "Setting the Functions of the Multifunction Relays", page 67).

### 8.3.4 Setting Time-Dependent 1-Level Load Shedding

The time-dependent load shedding divides the day into two intervals (see Section 9.3 "Setting Time-Dependent Functions", page 95). You set the SOC limits that apply for each interval. For example, you can set that no loads are to be disconnected from the utility grid during the night where possible.

#### Significance of the SOC thresholds:

When the state of charge of the battery reaches the lower SOC threshold, the multifunction relay opens the connected load-shedding contactor. The load-shedding contactor disconnects the loads from the utility grid. When the state of charge of the battery reaches the upper SOC threshold during recharging, the multifunction relay closes the connected load-shedding contactor. The load-shedding contactor connects the loads to the utility grid.

---

**Example: From 10:00 p.m. to 6:00 a.m., the load-shedding contactor is not to disconnect the loads from the utility grid where possible.**

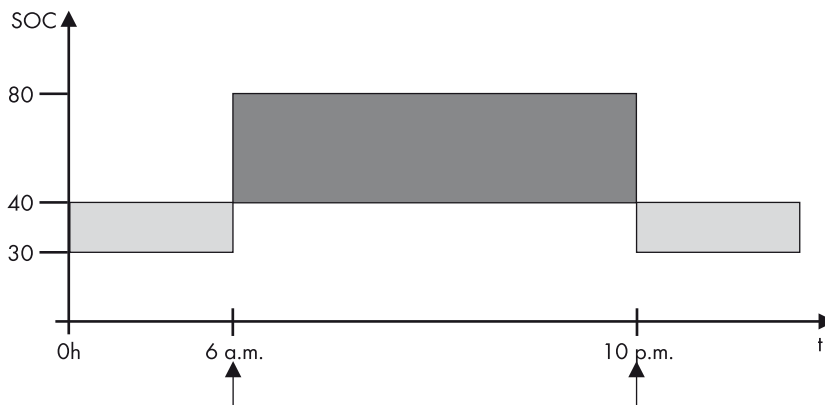

Figure 23: Profile of the SOC thresholds for controlling the load-shedding contactor and the start times for the intervals

The start time for the first interval is set to 6:00 a.m. The lower SOC threshold is set to 40% and the upper SOC threshold is set to 80% in this time interval.

The start time for the second interval is set to 10:00 p.m. The lower SOC threshold is set to 30% and the upper SOC threshold is set to 40% in this time interval.

#### Requirement:

- In a cluster, the Sunny Remote Control must be connected to the master.

#### Procedure:

1. Switch to installer mode on the Sunny Remote Control (see Sunny Island operating manual).
2. Select the parameter **242.05 Lod1Tm1Str** and set to the start time for the first interval.
3. Select the parameter **242.06 Lod1Tm2Str** and set to the start time for the second interval.
4. Select the **242.01 Lod1SocTm1Str** parameter and set it to the lower SOC threshold for the first interval.
5. Select the **242.02 Lod1SocTm1Stp** parameter and set it to the upper SOC threshold for the first interval.
6. Select the **242.03 Lod1SocTm2Str** parameter and set it to the lower SOC threshold for the second interval.
7. Select the **242.04 Lod1SocTm2Stp** parameter and set it to the upper SOC threshold for the second interval.
8. Ensure that the multifunction relay used for control is set to **AutoLod1 Soc** (see Section 8.1.5 "Setting the Functions of the Multifunction Relays", page 67).

### 8.3.5 Setting Time-Dependent 2-Level Load Shedding

The time-dependent load shedding divides the day into two intervals (see Section 9.3 "Setting Time-Dependent Functions", page 95). You set the SOC limits that apply for each interval for two-level load shedding. For example, you can set that as far as possible no loads are to be disconnected from the utility grid during the day.

#### Significance of the SOC thresholds:

Two lower and two upper SOC thresholds are available for each interval for controlling the load-shedding contactors. The load-shedding contactors disconnect the loads from the utility grid if the states of charge are as follows:

- When the state of charge of the battery reaches the first lower SOC threshold, the multifunction relay opens the connected load-shedding contactor for the first level of load shedding. The load-shedding contactor disconnects those loads from the utility grid that are to be disconnected for the first level.
- When the state of charge of the battery reaches the second lower SOC threshold, the multifunction relay opens the connected load-shedding contactor for the second level of load shedding. The load-shedding contactor disconnects the remaining loads from the utility grid.
- When the state of charge of the battery reaches the second upper SOC threshold during recharging, the multifunction relay closes the connected load-shedding contactor for the second level of load shedding. The load-shedding contactor connects those loads to the utility grid that were disconnected for the second level.
- When the state of charge of the battery reaches the first upper SOC threshold during recharging, the multifunction relay closes the connected load-shedding contactor for the first level of load shedding. The load-shedding contactor connects those loads to the utility grid that were disconnected for the first level. All loads are now reconnected to the utility grid.

#### Requirement:

- In a cluster, the Sunny Remote Control must be connected to the master.

#### Procedure:

1. Switch to installer mode on the Sunny Remote Control (see Sunny Island operating manual).
2. Select the parameter **242.05 Lod1Tm1Str** and set to the start time for the first interval.
3. Select the parameter **242.05 Lod1Tm2Str** and set to the start time for the second interval.
4. Setting the SOC threshold for the first interval:
  - Select the **242.01 Lod1SocTm1Str** parameter and set it to the lower SOC threshold for the first level of load shedding.
  - Select the **242.02 Lod1SocTm1Stp** parameter and set it to the upper SOC threshold for the first level of load shedding.
  - Select the **242.07 Lod2SocTm1Str** parameter and set it to the lower SOC threshold for the second level of load shedding.
  - Select the **242.08 Lod2SocTm1Stp** parameter and set it to the upper SOC threshold for the second level of load shedding.
5. Setting the SOC threshold for the second interval:
  - Select the **242.03 Lod1SocTm2Str** parameter and set it to the lower SOC threshold for the first level of load shedding.
  - Select the **242.04 Lod1SocTm2Stp** parameter and set it to the upper SOC threshold for the first level of load shedding.
  - Select the **242.09 Lod2SocTm2Str** parameter and set it to the lower SOC threshold for the second level of load shedding.
  - Select the **242.10 Lod2SocTm2Stp** parameter and set it to the upper SOC threshold for the second level of load shedding.
6. Ensure that the multifunction relay used for controlling the first level of load shedding is set to **AutoLod1Soc** (see Section 8.1.5 "Setting the Functions of the Multifunction Relays", page 67).
7. Ensure that the multifunction relay used for controlling the second level of load shedding is set to **AutoLod2Soc**.

### 8.3.6 Setting Energy Saving Modes in Battery Backup Systems

There are two energy saving mode types:

- Self-Consumption Silent mode
- Battery Silent mode

#### Self-Consumption Silent Mode for Systems for Increased Self-Consumption:

In systems for increased self-consumption, the Sunny Island switches into silent mode when the state of charge of the battery reaches the PVRes range and no energy is being fed into the utility grid (see Section 8.2.3.2, page 71). The Sunny Island leaves the silent mode when energy is being fed into the utility grid or the state of charge reaches the lower threshold of the PVRes range.

This Self-Consumption Silent mode is activated in all systems and this function cannot be deactivated.

#### Battery Silent Mode for Battery Backup System:

In battery backup systems you can have the Sunny Island switch into a silent mode when the Battery Silent mode is active and a definable time for float charge has run out. At the same time, the state of charge of the battery is maintained. The Sunny Island leaves silent mode at definable intervals or whenever the battery voltage per cell drops by 0.14 V. When the utility grid fails in silent mode, the Sunny Island leaves the non-operative mode and supplies the battery backup system. You can activate or deactivate the Battery Silent mode. The Battery Silent mode is only activated by default in battery backup systems without increased self-consumption.

When activating the Battery Silent mode in battery backup systems with increased self-consumption, pay attention to the following:

- The Sunny Island switches into non-operative mode only once the battery has been fully charged and the definable time **224.02 BatSilentTmFlo** has run out.
- The Sunny Island remains in non-operative mode until the time **224.03 BatSilentTmMax** has run out. The Sunny Island cannot optimize the self-consumption in silent mode.

In most systems it does not make sense to activate this function in battery backup systems with increased self-consumption.

#### Requirement:

- The system must be a battery backup system.

#### Procedure:

1. Switch to expert mode on the Sunny Remote Control (see Sunny Island operating manual).
2. To activate Battery Silent mode, set the values of the following parameters:
  - Select the parameter **224.01 BatSilentEna** and set it to **Enable**.
  - Select the parameter **224.02 BatSilentTmFlo** and set it to the maximum time for float charge.
  - Select the **224.03 BatSilentTmMax** parameter and set it to the maximum duration for energy-saving mode.
3. To deactivate Battery Silent mode, select the **224.01 BatSilentEna** parameter and set it to **Disable**.

### 8.3.7 Setting Utilization of Excess Energy in Off-Grid Systems

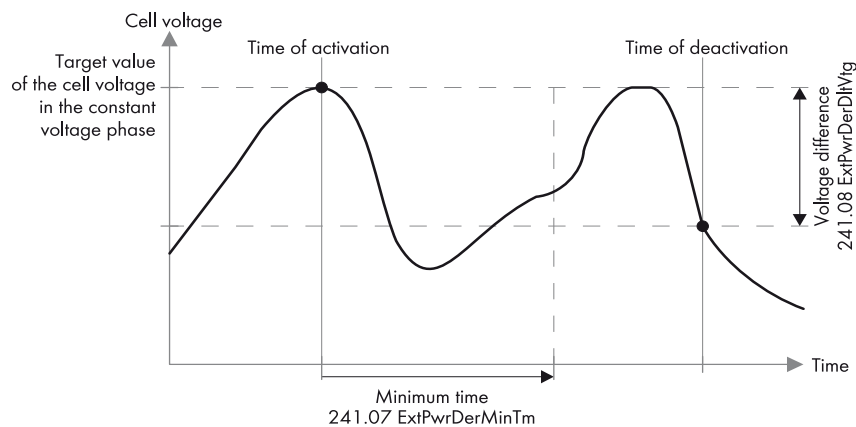

Figure 24: Switching-on time and switching-off time for utilization of excess energy during constant voltage phase

The Sunny Island controls the utilization of excess energy during the constant voltage phase depending on the cell voltage of the battery. During the constant voltage phase, the battery is charged with a constant charging voltage. When the setpoint of the cell voltage in the constant voltage phase is reached, the multifunction relay is activated. The multifunction relay remains in this position for the minimum time **241.07 ExtPwrDerMinTm**. If the cell voltage differs by more than **241.08 ExtPwrDerDltVtg** from the setpoint of the cell voltage, the multifunction relay is deactivated. The setpoint of the cell voltage depends on the charging process during the constant voltage phase.

Charging process	Parameter	Default value
Fast charge	222.07 ChrgVtgBoost	2.40 V
Full charge	222.08 ChrgVtgFul	2.45 V
Equalization charge	222.09 ChrgVtgEqu	2.45 V

To control the utilization of excess energy, set the multifunction relay as follows:

#### Procedure:

1. Switch to installer mode on the Sunny Remote Control (see Section 8.4).
2. Select the **241.07 ExtPwrDerMinTm** parameter and set it to the minimum time that the multifunction relay remains activated.
3. Select the **241.08 ExtPwrDerDltVtg** parameter and set it to the voltage difference relative to the setpoint of the cell voltage during the constant voltage phase.

#### **i** Recording of the measured values of the cell voltage reacts to changes with time-lag

The Sunny Island calculates the cell voltage from the measured battery voltage. The Sunny Island calculates an average from the measured values of the battery voltage. As a result of the calculation of an average, the cell voltage that is recorded reacts to changes with time-lag.

4. Ensure that the multifunction relay used for control is set to **ExtPwrDer** (see Section 8.1.5 "Setting the Functions of the Multifunction Relays", page 67).

## 8.4 Generator Management

### 8.4.1 Configuring the Thresholds for the Generator Terminal

#### 8.4.1.1 Changing the Current Thresholds for the Generator

**Significance of the current limits:**

The generator management limits the intake of generator current to the set maximum value.

In three-phase systems, the generator current is limited for each line conductor individually. The set value also applies for each line conductor.

For Sunny Island inverters that are operated in parallel, the generator management only limits the total generator current. The generator current may be unequally distributed to the Sunny Island inverters. If a Sunny Island fails, for example, more current correspondingly flows through the remaining Sunny Island inverters.

**Extended generator management:**

If the set generator current is not sufficient for supplying the loads, the generator management requests additional current from the battery. The system then supplies the loads with the generator current and the battery current.

**Procedure:**

1. Switch to installer mode on the Sunny Remote Control (see Sunny Island operating manual).
2. Select the parameter **234.03 GnCurNom** and set to the desired value. Tip: A suitable value for the **234.03 GnCurNom** parameter is 80% of the maximum generator current per line conductor.

#### 8.4.1.2 Changing the Voltage Thresholds for the Generator

The voltage thresholds determine the range within which the generator voltage is allowed to fluctuate.

When the Sunny Island switches to the generator, the stand-alone grid will also fluctuate within this range.

A breach of the set voltage thresholds leads to disconnection of the line conductor from the stand-alone grid or the generator not being switched on.

**Procedure:**

1. Switch to expert mode on the Sunny Remote Control (see Sunny Island operating manual).
2. Select the parameter **234.01 GNVtgMin** and set to the minimum generator voltage.
3. Select the parameter **234.02 GNVtgMax** and set to the maximum generator voltage.

#### 8.4.1.3 Changing the Frequency Thresholds of the Generator Voltage

The frequency thresholds determine the range within which the frequency of the generator voltage is allowed to fluctuate. When the Sunny Island switches to the generator, the stand-alone grid will also fluctuate within this range.

A breach of the set frequency thresholds leads to disconnection of the line conductor from the stand-alone grid or to the generator not being switched on.

**Procedure:**

1. Switch to expert mode on the Sunny Remote Control (see Sunny Island operating manual).
2. Select the parameter **234.04 GnFrqNom** and set to the rated frequency of the generator voltage.
3. Select the parameter **234.05 GnFrqMin** and set to the minimum frequency of the generator voltage.
4. Select the parameter **234.06 GnFrqMax** and set to the maximum frequency of the generator voltage.

#### 8.4.1.4 Changing the Permitted Reverse Power in the Generator

If the reverse power for the set time is exceeded, all Sunny Island inverters disconnect the generator from the stand-alone grid and block the connection of the generator to the stand-alone grid for the minimum stop time.

##### NOTICE

##### Damage to the generator

In the event of reverse power, the AC sources in the stand-alone grid drive the generator. The generator can be damaged as a result.

- Observe the information from the manufacturer about the reverse power protection of the generator.
- Set the generator reverse power and permitted time for reverse power according to the manufacturer's data.

##### Procedure:

1. Switch to expert mode on the Sunny Remote Control (see Sunny Island operating manual).
2. Select the parameter **234.13 GnRvPwr** and set to the active power of the generator reverse power.
3. Select the parameter **234.14 GnRvTm** and set to the time for the generator reverse power.

#### 8.4.1.5 Configuring the Current Limit for the Generator Depending on the Frequency

The higher the generator current, the higher the torque for the generator. In case of unregulated generators, the speed of rotation decreases with increasing torque. If the speed of rotation decreases, the frequency of the generator voltage is reduced.

If the frequency of the generator voltage and the rated frequency is reduced, the generator management can additionally limit the generator current. The lower the frequency, the more the generator current is limited by the generator management. This setting is useful if the generator is supplying other loads parallel to the Sunny Island. This setting allows the maximum load to be placed on the generator without overloading it.

##### Requirement:

- The generator must not be an inverter generator. The output frequency of the inverter generator is fixed.

##### Procedure:

1. Switch to expert mode on the Sunny Remote Control (see Sunny Island operating manual).
2. Select the parameter **234.03 GnCurNom** and set to the desired value. Tip: A suitable value for the **234.03 GnCurNom** parameter is 80% of the maximum generator current per line conductor.
3. Select the parameter **234.15 GnCflMod** and set to **CurFrq**. This will activate the frequency-dependent current limiting.

#### 8.4.2 Changing the Type of the Generator Interface

If you have installed a generator in the system, the type of generator interface determines the way the generator is controlled.

##### Procedure:

1. Switch to installer mode on the Sunny Remote Control (see Sunny Island operating manual).
2. If the generator has an autostart function, select the parameter **234.07 GnStrMod** and set to **Autostart**.
3. If the generator does not have an autostart function, select the parameter **234.07 GnStrMod** and set to **Manual**.

## 8.4.3 Configuring Generator Run-Times

### 8.4.3.1 Changing the Warm-Up Time for the Generator

#### Relation between warm-up time and termination of generator start:

The generator management measures the time between the generator start and the beginning of the warm-up time. If a maximum time is exceeded, the generator management terminates the generator start. The maximum time to start termination is double the warm-up time plus an additional two minutes.

For several generator types, the generator only switches the voltage to the output of the generator following the expiration of the warm-up time. During this time, the generator management cannot detect any applicable generator voltage. If the warm-up time is set too low, the generator management terminates the generator start before the internal warm-up time of the generator has expired.

#### Procedure:

1. Switch to installer mode on the Sunny Remote Control (see Sunny Island operating manual).
  2. For generators without internal warm-up time:
    - Select the parameter **234.12 GnWarmTm** and set to the desired warm-up time.
  3. For generators with an internal warm-up time:
    - For generators with an autostart function, select the **234.12 GnWarmTm** parameter and set the warm-up time to be at least half the internal warm-up time of the generator.
    - For generators without an autostart function, select the **234.12 GnWarmTm** parameter and set the warm-up time to be at least half the internal warm-up time of the generator.
- The generator start is not terminated prematurely.

### 8.4.3.2 Changing the Minimum Run Time for the Generator

1. Switch to installer mode on the Sunny Remote Control (see Sunny Island operating manual).
2. Select the parameter **234.08 GnOpTmMin** and set to the desired value.

### 8.4.3.3 Changing the Power-Down Time for the Generator

#### Internal shut-off delay of the generator

Generators can have an internal shut-off delay that is activated only when the generator request has been disabled. Ensure that this internal shut-off delay increases the actual power-down time.

#### Procedure:

1. Switch to installer mode on the Sunny Remote Control (see Sunny Island operating manual).
2. Select the parameter **234.10 GnCoolTm** and set to the desired value.

### 8.4.3.4 Changing the Minimum Stop Time for the Generator

1. Switch to installer mode on the Sunny Remote Control (see Sunny Island operating manual).
2. Select the parameter **234.09 GnStpTmMin** and set to the desired value.



## 8.4.4 Configuring the Generator Request

### 8.4.4.1 Changing the Automatic Generator Operation

In automatic generator operation, the generator management specifies when and for how long the generator runs, depending on the configuration.

**Procedure:**

1. Switch to installer mode on the Sunny Remote Control (see Sunny Island operating manual).
2. To deactivate automatic generator mode, select the **235.01 GnAutoEna** parameter and set it to **Disable**.
3. To activate automatic generator mode, select the **235.01 GnAutoEna** parameter and set it to **Enable**.

### 8.4.4.2 Changing a State-Of-Charge-Dependent Generator Request

If the battery reaches the lower SOC threshold, the generator management requests the generator. If the battery reaches the upper SOC threshold during recharging, the generator management resets this generator request.

**Procedure:**

1. Switch to installer mode on the Sunny Remote Control (see Sunny Island operating manual).
2. Select the **235.03 GnSocTm1Str** parameter and set it to the lower SOC threshold.
3. Select the **235.04 GnSocTm1Stp** parameter and set it to the upper SOC threshold.
4. Set the **235.07 GnTm1Str** and **235.08 GnTm2Str** parameters to the same value, e.g. both to **000000**.  
This deactivates the time-dependent generator request.

### 8.4.4.3 Setting a Time-Dependent Generator Request

The time-dependent generator request divides the day into two intervals. For each interval, you set which conditions there are for the generator request (see Section 9.3 "Setting Time-Dependent Functions", page 95). In this way, you can e.g. set the generator not to start at night. This ensures that the noise pollution produced by the generator takes place during the day whenever possible.

Both intervals have a lower and an upper SOC threshold each. If the battery reaches the lower SOC threshold, the generator management requests the generator. When the battery reaches the upper SOC threshold during recharging, generator management resets this generator request. The following settings are possible for the SOC thresholds:

- The lower SOC threshold is smaller than the upper SOC threshold.  
The generator is requested during this interval depending on the state of charge.
- The lower SOC threshold is greater than or equal to the upper SOC threshold.  
The generator is not started depending on the state of charge. During this interval, the special settings for a generator request apply, e.g. the load-dependent generator request.

**Example: From 10:00 p.m. to 6:00 a.m., the generator is not to start where possible.**

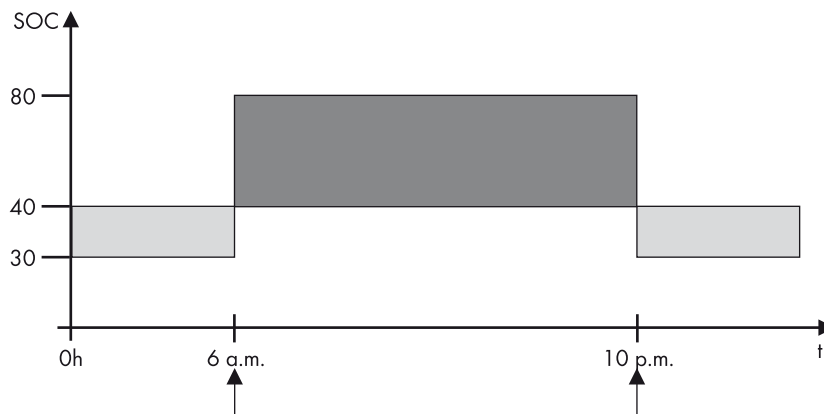

Figure 25: Profile of the SOC and the times for generator requests

The start time for the first interval is set to 6:00 a.m. In the first interval, the lower SOC threshold is set to 40% and the upper SOC threshold is set to 80%.

The start time for the second interval is set to 10:00 p.m. In the second interval, the lower SOC threshold is set to 30% and the upper SOC threshold is set to 40%.

#### Procedure:

1. Switch to installer mode on the Sunny Remote Control (see Sunny Island operating manual).
2. Select the parameter **235.07 GnTm1Str** and set the start time for the first interval.
3. Select the **235.03 GnSocTm1Str** parameter and set it to the lower SOC threshold during the first interval.
4. Select the **235.04 GnSocTm1Stp** parameter and set it to the upper SOC threshold during the first interval.
5. Select the parameter **235.08 GnTm2Str** and set to the start time for the second interval.
6. Select the **235.05 GnSocTm2Str** parameter and set it to the lower SOC threshold during the second interval.
7. Select the **235.06 GnSocTm2Stp** parameter and set it to the upper SOC threshold during the second interval.

#### 8.4.4.4 Configuring the Load-Dependent Generator Request

##### Significance of the load-dependent generator request:

If you activate the load-dependent generator request, the Sunny Island requests the generator in the event of a high load. This prevents the battery from deep electric discharging and cycling and extends its service life. The output power of the off-grid system for powering the loads increases to the total of the generator output and the output of the Sunny Island. This improves the system stability. The load is the calculated average output power of the Sunny Island.

##### Loads in a three-phase system:

The generator management considers the total load of all phases. It does not monitor single phases in three-phase systems. If the switch-on power limit is exceeded, the generator management requests the generator.

##### Time-based procedure of the load-dependent generator request:

If the switch-on power limit is reached, the generator management requests the generator. If the load connected to the switch-off power limit is reduced, the generator management resets the generator request again following the minimum run time. The generator management does not capture the load as an instantaneous value. The generator management calculates the load during the averaging time **235.12 GnPwrAvgTm**. The greater the averaging time that you set, the less the generator management reacts to load peaks.

**Generator run times:**

Following the generator start, the warm-up, minimum, and power-down times are maintained. The power of the generator is not immediately available in the stand-alone grid. Each start also means that the generator runs for at least the warm-up time, minimum run time and power-down time.

**Procedure:**

1. Switch to expert mode on the Sunny Remote Control (see Sunny Island operating manual).
2. Select the **235.09 GnPwrEna** parameter and set it to **Enable**. This will activate the load-dependent generator request.
3. Select the parameter **235.10 GnPwrStr** and set to the switch-on power limit.
4. Select the parameter **235.11 GnPwrStp** and set to the switch-off power limit.
5. Select the parameter **235.12 GnPwrAvgTm** and set to the averaging time, with which the generator management calculates the average power.

**8.4.4.5 Time-Controlled Generator Requesting**

If the generator is requested dependent on time, it is requested on certain days for a set duration (see Section 9.4 "Setting Time-Controlled Functions", page 96).

**Procedure:**

1. Select the **235.13 GnTmOpEna** parameter and set it to **Enable**.
2. Select the **235.14 GnTmOpStrDt** parameter and set it to the desired start date.
3. Select the **235.15 GnTmOpStrTm** parameter and set it to the desired start time.
4. Select the **235.16 GnTmOpRnDur** parameter and set it to the desired duration.
5. Select the **235.17 GnTmOpCyc** parameter and set it to the desired repetition cycle:

Value	Explanation
Single	Single generator request on the start date
Daily	Daily generator request starting on the start date
Weekly	Weekly generator request starting on the start date The start date determines the weekday.

**8.4.4.6 Changing the Generator Request via the Charging Process of the Battery**

1. Switch to expert mode on the Sunny Remote Control (see Sunny Island operating manual).
2. Select the parameter **235.18 GnStrChrgMod** and set to the desired generator request:

Value	Explanation
Equal	Generator request during equalization charge
Full	Generator request during full charge
Both	Generator request during equalization and full charge
Off	Deactivation of the generator request via the charging process of the battery

#### 8.4.4.7 Setting an External Generator Request

An external control signal can communicate a generator request to the generator management.

**Procedure:**

1. Switch to expert mode on the Sunny Remote Control (see Sunny Island operating manual).
2. In order to activate the external generator request, select the parameter **235.19 GnStrDigIn** and set to **Enable**.
3. In order to deactivate the external generator request, select the parameter **235.19 GnStrDigIn** and set to **Disable**.

#### 8.4.5 Configuring the Procedure in the Event of a Generator False Start

**Operating procedure if a generator false start is detected**

If the Sunny Island detects a generator false start (e.g. voltage too high), the Sunny Island does not switch the stand-alone grid to the generator.

If there is another request for the generator after the minimum stop time, the Sunny Island attempts to start the generator.

If the Sunny Island detects a false start on numerous occasions and the number of failed attempts exceeds the maximum value, the Sunny Island switches into error status.

After the stop time **234.11 GnErrStpTm** has run out, the Sunny Island tries to restart the generator.

**Single cluster systems:**

The generator management evaluates a fault in the line conductor at the master as a failure of the generator. All Sunny Island inverters disconnect the stand-alone grid from the generator.

The generator management treats a fault in the line conductor of the slave as a line conductor fault. The slave only disconnects the affected line conductor from the stand-alone grid. The slave switches the stand-alone grid to the generator again if the faulty line conductor is in the valid range.

**Procedure:**

1. Switch to expert mode on the Sunny Remote Control (see Sunny Island operating manual).
2. In order to change the maximum number of failed attempts:
  - Select the **235.01 GnAutoEna** parameter and set it to **Enable**.
  - Select the parameter **235.02 GnAutoStr** and set to the desired number of start attempts.
3. In order to change the stop time of the generator after the maximum number of start attempts has been exceeded, select the parameter **234.11 GnErrStpTm** and set to the desired stop time.

## 8.5 Setting the Time Control

The time control controls up to two multifunction relays according to the set times.

### Procedure:

1. Switch to installer mode on the Sunny Remote Control (see Sunny Island operating manual).
2. To set timer 1, set the start date, start time, duration and repetition cycle:
  - Select the **243.01 RlyTmr1StrDt** parameter and set it to the desired start date.
  - Select the **243.02 RlyTmr1StrTm** parameter and set it to the desired start time.
  - Select the **243.03 RlyTmr1Dur** parameter and set it to the desired duration.
  - Select the **243.04 RlyTmr1Cyc** parameter and set it to the desired repetition cycle.
  - Ensure that the multifunction relay used for control is set to **Tm1** (see Section 8.1.5 "Setting the Functions of the Multifunction Relays", page 67).
3. To set timer 2, set the start date, start time, duration and repetition cycle:
  - Select the **243.05 RlyTmr2StrDt** parameter and set it to the desired start date.
  - Select the **243.06 RlyTmr2StrTm** parameter and set it to the desired start time.
  - Select the **243.07 RlyTmr2Dur** parameter and set it to the desired duration.
  - Select the **243.08 RlyTmr2Cyc** parameter and set it to the desired repetition cycle.
  - Ensure that the multifunction relay used for control is set to **Tm2** (see Section 8.1.5 "Setting the Functions of the Multifunction Relays", page 67).

## 8.6 Changing Thresholds for Systems for Increased Self-Consumption

The Sunny Island 6.0H meets the requirements of application rule: "VDE-AR-N 4105: 2011-08 - Erzeugungsanlagen am Niederspannungsnetz, Technische Mindestanforderungen für Anschluss und Parallelbetrieb von Erzeugungsanlagen am Niederspannungsnetz". The application rule is enclosed with the Sunny Island as standard country data set VDE-AR-4105.

Adjusting the settings for connecting the Sunny Island to the utility grid is necessary in various countries.

### Procedure:

- If the operation of the Sunny Island connected to the utility grid is allowed and an adjustment is necessary, change the Sunny Island according to the documentation (see [www.SMA-Solar.com](http://www.SMA-Solar.com)).

## 8.7 Changing the Automatic Frequency Synchronization in Off-Grid Systems

The automatic frequency synchronization enables the use of timepieces that use the power frequency as a timer. The power frequency dictates the accuracy of the timepiece. For power frequencies with constant frequency deviations from the rated frequency, the time indications will become ever more inaccurate.

Continuous frequency deviations occur, e.g. in off-grid systems with generators. If the automatic frequency synchronization is activated, the Sunny Island regulates the frequency deviations over time. As a result, the accuracy of clocks that use the power frequency as timers is increased.

### Procedure:

1. Switch to expert mode on the Sunny Remote Control (see Sunny Island operating manual).
2. To deactivate automatic frequency synchronization, select the **250.11 AfraEna** parameter and set it to **Disable**.
3. To activate automatic frequency synchronization, select the **250.11 AfraEna** parameter and set it to **Enable**.

## 8.8 Completing Commissioning

1. Make sure that the wiring is correct (see Section 7.6, page 59).
2. Ensure that the functional test has been carried out (see "Installation - Quick Reference Guide" of the system used).
3. Connect or close the circuit breakers and fuse switch-disconnectors for energy sources.
4. Only with off-grid systems disconnect or open all loads, the circuit breakers of the loads and the fuse-switch-disconnector. As a result, only the energy sources are connected to the Sunny Island.
5. Press the start-stop button on the Sunny Island and hold it until an acoustic signal sounds.

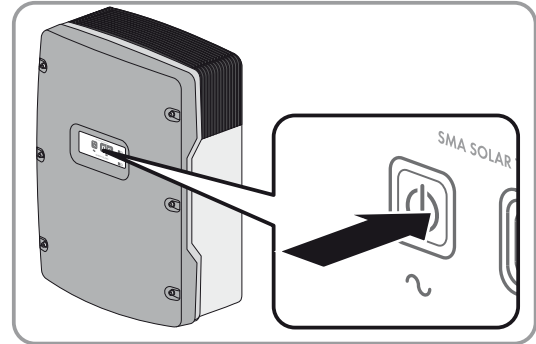

- ☑ The Sunny Island starts charging the battery automatically.
6. When full charge is complete, switch on all circuit breakers and load-break switches with off-grid systems only. Tip: The state of charge of the battery is displayed on the Sunny Remote Control in standard mode.

### **i** Load shedding in the first two operating hours

The state of charge (SOC) recorded by the battery management and the available battery capacity (SOH) will deviate strongly from the actual values of SOC and SOH for a newly connected battery. During operation, the values recorded by the battery management will gradually approach the real values. In the first two operating hours with the new battery, these deviations can lead to load shedding and corresponding entries in the **400# Failure/Event** menu.

## 9 Supplementary Information

### 9.1 Entering the SMA Grid Guard Code

Depending on the configuration, safety-relevant parameters are protected by the SMA Grid Guard code from unauthorized changes. You can unlock the parameters by entering the SMA Grid Guard code.

**Procedure:**

1. Contact the SMA Service Line and apply for a personal SMA Grid Guard code.
  2. Switch to expert mode on the Sunny Remote Control (see Sunny Island operating manual).
  3. Select the parameter **270.01 Auth.Code** and set the SMA Grid Guard code.
- Safety-relevant parameters can now be changed.

### 9.2 Determining the Battery Capacity

Manufacturers state the battery capacity depending on the discharge time. In the configuration of the off-grid system and in the QCG, you always enter the battery capacity for a 10-hour electric discharge (C10).

**Procedure:**

- Determine the battery capacity C10 specified by the battery manufacturer.
  - You could determine the battery capacity C10.
  - You could not determine the battery capacity C10?
    - Estimate the battery capacity C10 from other discharge times. This will provide a value that is probably sufficient for commissioning.

Discharging time	Estimation
120 h (C120)	$C10 = C120 / 1.28$
100 h (C100)	$C10 = C100 / 1.25$
20 h (C20)	$C10 = C20 / 1.09$
10 h (C10)	$C10 = C10$
5 h (C5)	$C10 = C5 / 0.88$
1 h (C1)	$C10 = C1 / 0.61$

- Contact the battery manufacturer, request the C10 battery capacity and set the correct battery capacity in the QCG as soon as possible. Proceed as if you were replacing the battery (replacing the battery, see Sunny Island operating manual).

### 9.3 Setting Time-Dependent Functions

With time-dependent functions, the day is divided into two intervals such as time-dependent load shedding. You specify the intervals using two points in time. The first interval starts with point in time 1 and ends with point in time 2. The second interval starts with point in time 2 and ends with point in time 1.

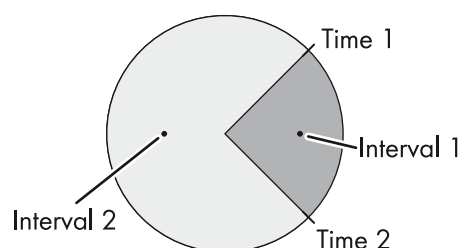

Figure 26: Division of the time of day into two intervals

## 9.4 Setting Time-Controlled Functions

For time-controlled functions, you set the start time, duration and repetition type.

---

### Example: Time-controlled operation of a generator

If you want the generator to run every Monday from 07:00 a.m. to 08:00 a.m., set the generator as follows:

- **235.13 GnTmOpEna:** Enable (activation of the function)
  - **235.14 GnTmOpStrDt:** 09.01.2012 (2012-01-09 Monday)
  - **235.15 GnTmOpStrTm:** 07:00:00 (start time)
  - **235.16 GnTmOpRnDur:** 01:00:00 (duration)
  - **235.17 GnTmOpCyc:** Weekly (repetition type)
-



## 10 Technical Data

### 10.1 AC1 Connection for Stand-Alone Grid

	Sunny Island 6.0H	Sunny Island 8.0H
Rated power	4,600 W	6,000 W
Maximum power	12,000 W	12,000 W
Power for 30 minutes at 25°C	6,000 W	8,000 W
Power for 5 minutes at 25°C	6,800 W	9,100 W
Power for 1 minute at 25°C	7,500 W	9,600 W
Maximum AC power for 3 s at 25°C	11,000 W	11,000 W
Maximum connectable power of the PV inverters in off-grid systems	9,200 W	12,000 W
Rated grid voltage	230 V	230 V
Voltage range	202 V to 253 V	202 V to 253 V
Rated frequency	50 Hz	50 Hz
Frequency range	45 Hz to 65 Hz	45 Hz to 65 Hz
Frequency range of the set range	±5 Hz	±5 Hz
Rated current	20 A	26.1 A
Maximum output current as a peak value for 60 milliseconds	120 A	120 A
Total harmonic distortion of the output voltage (THD)	< 4%	< 4%
Displacement power factor $\cos \varphi$	- 1 to +1	- 1 to +1
Recommended conductor cross-section	10 mm <sup>2</sup>	10 mm <sup>2</sup>
Maximum connectable conductor cross-section	16 mm <sup>2</sup>	16 mm <sup>2</sup>
Cable diameter	9 mm to 18 mm	9 mm to 18 mm
Terminal	Lever terminal	Lever terminal
Circuit breakers that can be tripped for selectivity	Tripping characteristics B16 and C6	Tripping characteristics B16 and C6

## 10.2 AC2 Connection for Utility Grid and Generator

	Sunny Island 6.0H	Sunny Island 8.0H
Maximum power in an off-grid system	11,500 W	11,500 W
Rated voltage	230 V	230 V
Voltage range	172.5 V to 264.5 V	172.5 V to 264.5 V
Rated frequency	50 Hz	50 Hz
Permitted frequency range	40 Hz to 70 Hz	40 Hz to 70 Hz
Maximum current in off-grid systems	50 A	50 A
Maximum current in systems for increased self-consumption with one Sunny Island in Germany	20.0 A	20.0 A
Maximum power in systems for increased self-consumption with one Sunny Island in Germany	4,600 W	4,600 W
Maximum connectable power of the PV inverters in battery backup systems	9,200 W	12,000 W
Maximum inrush current for 10 milliseconds	±1.5 A	±1.5 A
Recommended conductor cross-section	10 mm <sup>2</sup>	10 mm <sup>2</sup>
Maximum connectable conductor cross-section	16 mm <sup>2</sup>	16 mm <sup>2</sup>
Cable diameter	9 mm to 18 mm	9 mm to 18 mm
Terminal	Lever terminal	Lever terminal
Maximum back-up fuse	50 A	50 A
Circuit breakers that can be tripped for selectivity	Tripping characteristics B16 and C6	Tripping characteristics B16 and C6

## 10.3 DC Connection for Battery

	Sunny Island 6.0H	Sunny Island 8.0H
Rated input voltage	48 V	48 V
Voltage range	41 V to 63 V	41 V to 63 V
Rated charging current	90 A	115 A
Rated discharging current	103 A	136 A
Max. battery charging current	110 A	140 A
Battery type	Lead-acid battery: FLA, VRLA Lithium-ion battery	Lead-acid battery: FLA, VRLA Lithium-ion battery
Battery capacity range of lead-acid batteries	100 Ah to 10,000 Ah	100 Ah to 10,000 Ah
Battery capacity range of lithium-ion batteries	50 Ah to 10,000 Ah	50 Ah to 10,000 Ah
Recommended minimum battery capacity C10 in systems for increased self-consumption	100 Ah	100 Ah
Recommended minimum battery capacity C10 in battery backup systems	120 Ah	160 Ah
Recommended minimum battery capacity C10 in off-grid systems	190 Ah	250 Ah
Recommended minimum battery capacity C10 per 1,000 Wp power of PV systems in off-grid systems	100 Ah	100 Ah
Charge control for lead-acid batteries	IUoU charge procedure with automatic full charge and equalization charge	IUoU charge procedure with automatic full charge and equalization charge
DC connection	M8 terminal lug	M8 terminal lug
Permitted conductor cross-section	50 mm <sup>2</sup> to 95 mm <sup>2</sup>	50 mm <sup>2</sup> to 95 mm <sup>2</sup>
Maximum connectable conductor cross-section	95 mm <sup>2</sup>	95 mm <sup>2</sup>
Cable diameter	14 mm to 25 mm	14 mm to 25 mm
Maximum torque	12 Nm	12 Nm

## 10.4 Efficiency

	Sunny Island 6.0H	Sunny Island 8.0H
Maximum efficiency	95.8%	95.8%
European weighted efficiency	94.3%	94.1%

### 10.5 Sunny Island 6.0H Efficiency Profile

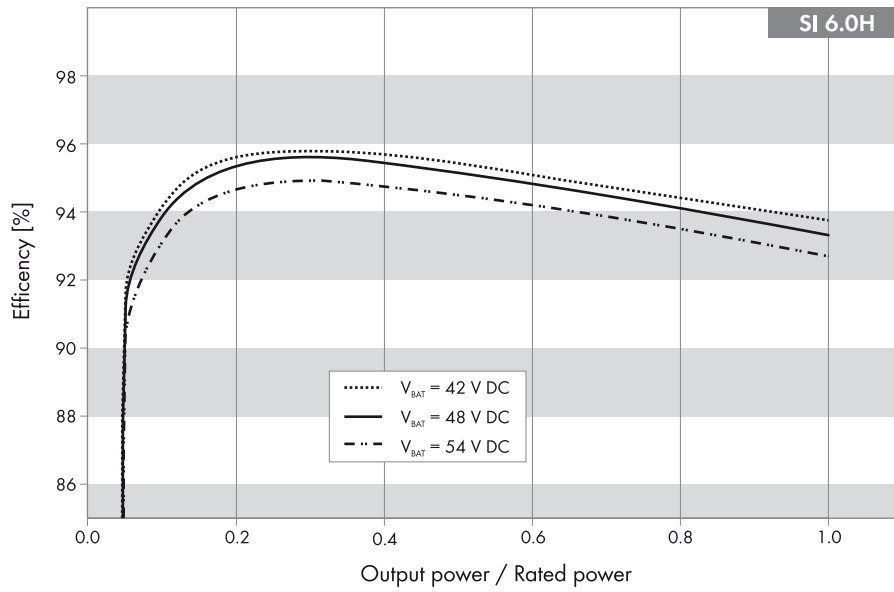

Figure 27: Characteristic efficiency curve

### 10.6 Sunny Island 8.0H Efficiency Profile

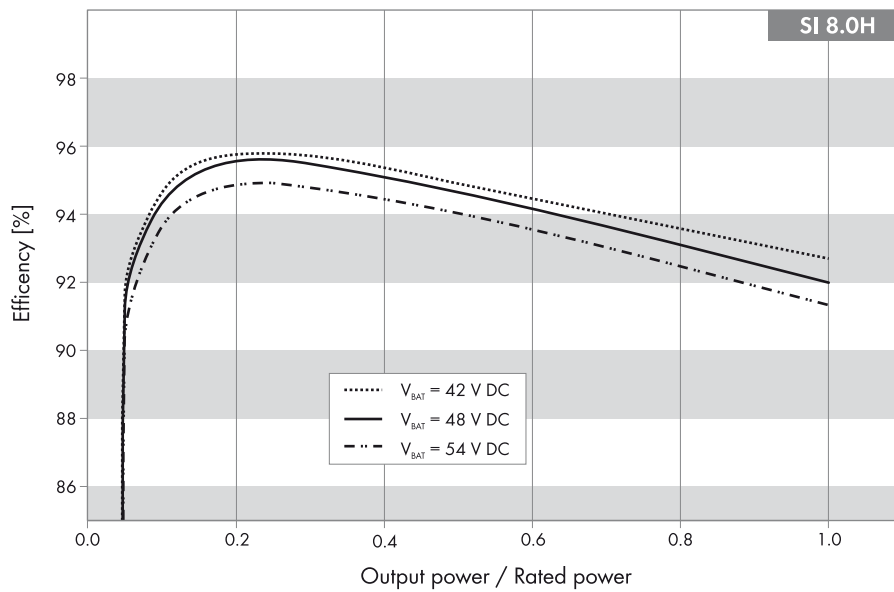

Figure 28: Characteristic efficiency curve

## 10.7 Power-Temperature Curve

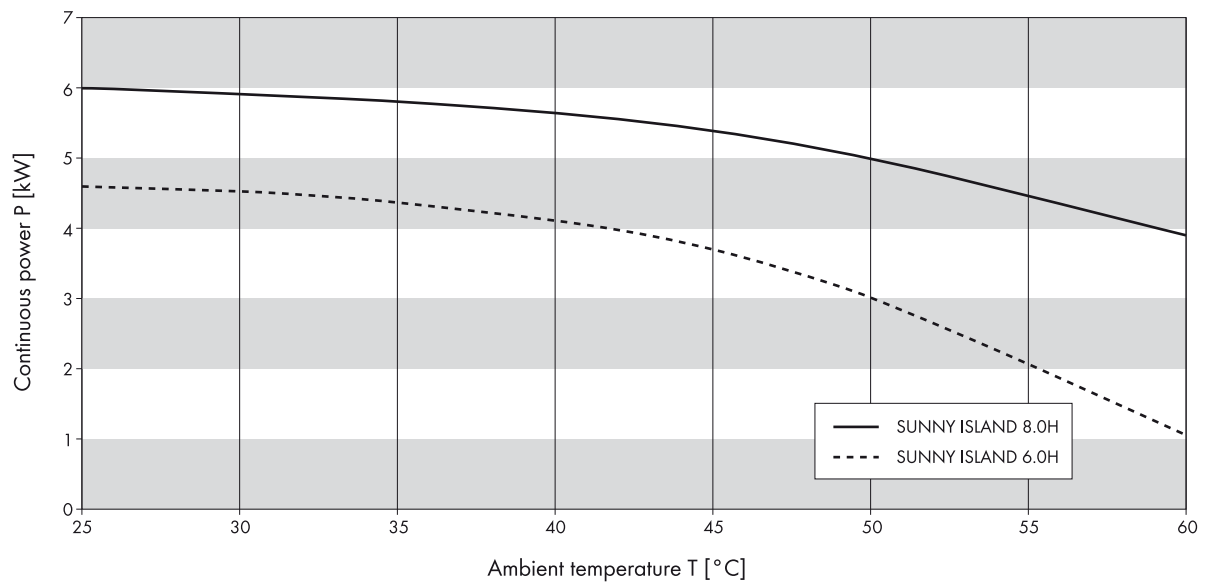

Figure 29: Power-temperature curve

## 10.8 Power Consumption

Standby consumption	< 4 W
Self-consumption in no-load operation and in discharge mode without SRC-20	< 26 W
Self-consumption in no-load operation and in discharge mode with SRC-20	< 27 W

## 10.9 Noise Emission

Noise emission, typical	49 dB(A)
-------------------------	----------

## 10.10 Grid Configuration

TN-S grid configuration	suitable
TN-C-S grid configuration	suitable
TT grid configuration	suitable

## 10.11 Protective Devices

AC short-circuit	yes
AC overload	yes
DC reverse-polarity protection	not available
Battery deep discharge	yes
Overtemperature	yes
Overvoltage category according to IEC 60664-1	III

## 10.12 Equipment

Number of buttons	3
Number of LEDs	3 two-color LEDs
Display	External display SRC-20
Number of interface slots	2
SWDMSI-xx	required in systems for increased self-consumption
SI-COMSMA.BGx	optional
COM SYNC	for internal communication only
SI-SYSCAN.BGx	optional
Number of digital control inputs	1
High level digital input	9 V to 63 V
Low level digital input	0 V to 3 V
Galvanically insulated control contacts	2 Multifunction relays
Number of terminals for battery current sensors	1
Measuring accuracy with connected battery current sensor	$\pm 10\%$
Maximum length of measuring cable on battery current sensor	3 m
AC load switching limit for multifunction relay 1 and 2	1 A at 250 V
DC load switching limit for multifunction relay 1 and 2	see Section 10.13, page 102

## 10.13 DC Load Limitation Curve of the Multifunction Relays

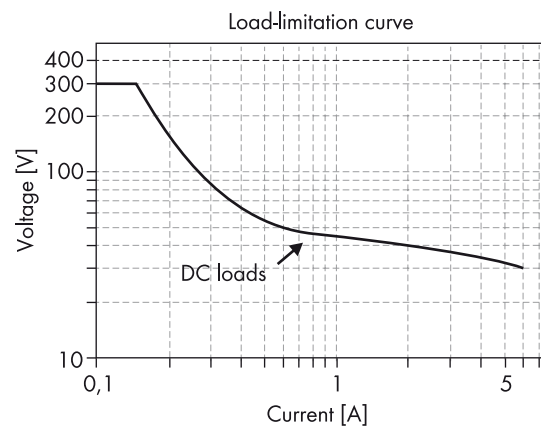

Figure 30: DC load limitation curve of multifunction relay 1 and 2

## 10.14 General Data

Width x height x depth	467 mm x 612 mm x 242 mm
Weight (kg)	63 kg
Operating temperature range	- 25°C to +60°C
Storage temperature range	- 25°C to +70°C
Humidity	0% to 100%
Maximum installation height above MSL	3,000 m
Topology	LF transformer
Cooling concept	OptiCool
Protection class according to IEC 62103	I
Climatic category according to IEC 60721	3K6
Degree of protection according to IEC 60529	IP54

## 11 Accessories

You will find the corresponding accessories and spare parts for your product in the following overview. If required, you can order them from SMA Solar Technology AG or from your distributor.

Designation	Brief description	SMA order number
Batfuse-B.01 (250 A)	2-pin LV/HRC battery fuse-switch-disconnector, size 1 for 1 Sunny Island, 3 DC inputs (1 x battery and 2 x Sunny Island Charger 50), 1 x auxiliary voltage output 8 A	BATFUSE-B.01
Batfuse-B.03 (250 A)	2-pin LV/HRC battery fuse-switch-disconnector, size 1 for up to three Sunny Island units, 6 DC inputs (2 x battery and 4 x Sunny Island Charger 50), 1 x auxiliary voltage output 8 A	BATFUSE-B.03
Load-shedding contactor	3-pole load-shedding contactor with 48 V DC coil for Sunny Island	SI-LS100-48
SI-Shunt	Battery current sensor  The battery current sensor is available in several versions. You can obtain more information from your distributor or SMA Solar Technology AG.	SI-SHUNTXXX
Sunny Island Charger 50	PV charge controller for off-grid systems	SIC50-MPT
SI-COMSMA.BGx	RS485 communication interface	SI-COMSMA-NR
SI-SYSCAN.BGx	Communication interface for communication between clusters in a multicluster system	SI-SYSCAN-NR
SWDMSI-NR10	Speedwire data module Sunny Island	SWDMSI-NR10



## 12 Contact

If you have technical problems concerning our products, contact the SMA Service Line. We require the following information in order to provide you with the necessary assistance:

- Type of Sunny Island
- Serial number of the Sunny Island
- Firmware version of the Sunny Island
- Displayed error message
- Type of battery connected
- Rated battery capacity
- Nominal battery voltage
- Type of the communication products connected
- Type and size of additional energy sources
- If a generator is connected:
  - Type
  - Power
  - Maximum current

Australia	SMA Australia Pty Ltd. Sydney	Toll free for Australia:	1 800 SMA AUS (1 800 762 287)
		International:	+61 2 9491 4200
Belgien/ Belgique/ België	SMA Benelux BVBA/SPRL Mechelen	+32 15 286 730	
Brasil	Vide España (Espanha)		
Česko	SMA Central & Eastern Europe s.r.o. Praha	+420 235 010 417	
Chile	Ver España		
Danmark	Se Deutschland (Tyskland)		
Deutschland	SMA Solar Technology AG Niestetal	Medium Power Solutions	
		Wechselrichter:	+49 561 9522-1499
		Kommunikation:	+49 561 9522-2499
		SMA Online Service Center:	<a href="http://www.SMA.de/Service">www.SMA.de/Service</a>
		Hybrid Energy Solutions	
		Sunny Island:	+49 561 9522-399
		Power Plant Solutions	
		Sunny Central:	+49 561 9522-299
España	SMA Ibérica Tecnología Solar, S.L.U. Barcelona	Llamada gratuita en España:	900 14 22 22
		Internacional:	+34 902 14 24 24

France	SMA France S.A.S. Lyon	Medium Power Solutions	
		Onduleurs :	+33 472 09 04 40
		Communication :	+33 472 09 04 41
		Hybrid Energy Solutions	
		Sunny Island :	+33 472 09 04 42
		Power Plant Solutions	
		Sunny Central :	+33 472 09 04 43
India	SMA Solar India Pvt. Ltd. Mumbai	+91 22 61713888	
Italia	SMA Italia S.r.l. Milano	+39 02 8934-7299	
Κύπρος/ Kıbrıs	Βλέπε Ελλάδα/ Bkz. Ελλάδα (Yunanistan)		
Luxemburg/ Luxembourg	Siehe Belgien/ Voir Belgien (Belgique)		
Magyarország	lásd Česko (Csehország)		
Nederland	zie Belgien (België)		
Österreich	Siehe Deutschland		
Perú	Ver España		
Polska	Patrz Česko (Czechy)		
Portugal	SMA Solar Technology Portugal, Unipessoal Lda Lisboa	Isento de taxas em Portugal: Internacional:	800 20 89 87 +351 2 12 37 78 60
România	Vezi Česko (Cehia)		
Schweiz	Siehe Deutschland		
Slovensko	pozri Česko (Česká republika)		
South Africa	SMA Solar Technology South Africa Pty Ltd. Centurion (Pretoria)	08600 SUNNY (08600 78669) International:	+27 (12) 643 1785
United Kingdom	SMA Solar UK Ltd. Milton Keynes	+44 1908 304899	
Ελλάδα	SMA Hellas AE Αθήνα	801 222 9 222 International:	+30 212 222 9 222
България	Вижте Ελλάδα (Γърция)		
ไทย	SMA Solar (Thailand) Co., Ltd. ปทุมธานี	+66 2 670 6999	
대한민국	SMA Technology Korea Co., Ltd. 서울	+82 2 508-8599	

中国	SMA Beijing Commercial Company Ltd. 北京	+86 10 5670 1350	
日本	SMA Japan K.K. 東京	+81 3 3451 9530	
+971 2 698-5080	SMA Middle East LLC أبو ظبي		الإمارات العربية المتحدة
Other countries	International SMA Service Line Niestetal	Toll free worldwide: 00800 SMA SERVICE (+800 762 7378423)	

**SMA Solar Technology**

**[www.SMA-Solar.com](http://www.SMA-Solar.com)**

