

Operating Manual

SUNNY ISLAND 4.4M / 6.0H / 8.0H

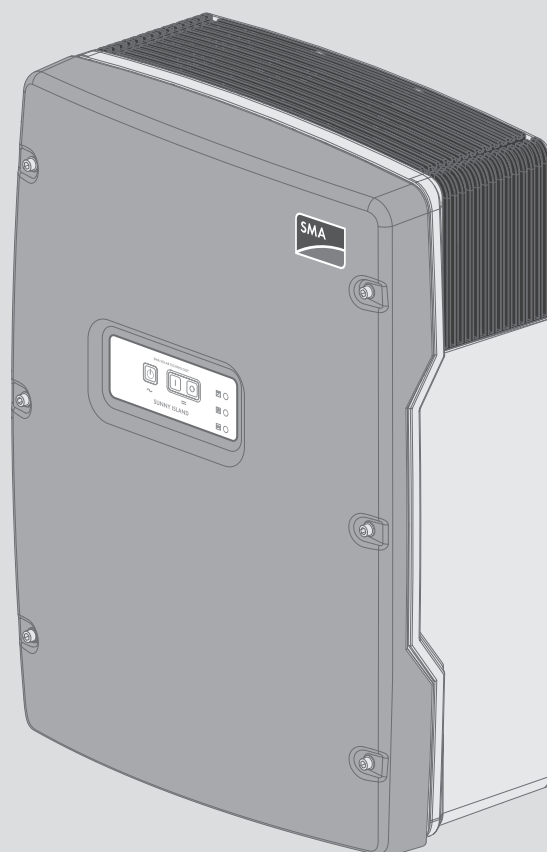

Legal Provisions

The information contained in these documents is property of SMA Solar Technology AG. Any publication, whether in whole or in part, requires prior written approval by SMA Solar Technology AG. Internal reproduction used solely for the purpose of product evaluation or other proper use is allowed and does not require prior approval.

SMA Warranty

You can download the current warranty conditions from the Internet at www.SMA-Solar.com.

Software licenses

The licenses for the used software modules can be called up on the user interface of the product.

Trademarks

All trademarks are recognized, even if not explicitly identified as such. Missing designations do not mean that a product or brand is not a registered trademark.

Modbus® is a registered trademark of Schneider Electric and is licensed by the Modbus Organization, Inc.

QR Code is a registered trademark of DENSO WAVE INCORPORATED.

Phillips® and Pozidriv® are registered trademarks of Phillips Screw Company.

Torx® is a registered trademark of Acument Global Technologies, Inc.

SMA Solar Technology AG

Sonnenallee 1

34266 Niestetal

Germany

Tel. +49 561 9522-0

Fax +49 561 9522-100

www.SMA.de

Email: info@SMA.de

Status: 9/19/2017

Copyright © 2017 SMA Solar Technology AG. All rights reserved.

Table of Contents

| | | |
|----------|---|-----------|
| 1 | Information on this Document | 8 |
| 1.1 | Validity | 8 |
| 1.2 | Target Group | 8 |
| 1.3 | Additional Information..... | 8 |
| 1.4 | Symbols..... | 8 |
| 1.5 | Typographies | 9 |
| 1.6 | Nomenclature | 9 |
| 2 | Safety | 11 |
| 2.1 | Intended Use..... | 11 |
| 2.2 | Safety Information | 12 |
| 2.3 | Battery Safety Information..... | 14 |
| 2.4 | Battery-Backup System Safety Information | 16 |
| 3 | Scope of Delivery | 18 |
| 4 | Product Description | 20 |
| 4.1 | Sunny Island..... | 20 |
| 4.2 | Interfaces and Functions..... | 21 |
| 4.3 | Control Panel | 23 |
| 4.4 | Multifunction Relay | 24 |
| 5 | Mounting | 25 |
| 5.1 | Requirements for Mounting..... | 25 |
| 5.2 | Mounting the Sunny Island | 27 |
| 6 | Electrical Connection | 30 |
| 6.1 | Content and Structure of the Section..... | 30 |
| 6.2 | Overview of the Connection Area..... | 31 |
| 6.3 | Inserting the Micro SD Card..... | 32 |
| 6.4 | Connecting the Grounding Conductor with a Grounded Battery | 32 |
| 6.5 | Connecting the Components | 33 |
| 6.5.1 | Connecting the Battery Fuse to the Sunny Island..... | 33 |
| 6.5.2 | Connecting the Utility Grid in the System for Increased Self-Consumption..... | 34 |
| 6.5.3 | Connecting an Automatic Transfer Switch in the Battery Backup System | 36 |
| 6.5.3.1 | Connecting the AC Power Cables of the Automatic Transfer Switch | 36 |
| 6.5.3.2 | Connecting the Control Cables of the Automatic Transfer Switch..... | 37 |
| 6.5.3.3 | Connecting the Measuring Cables of the Automatic Transfer Switch | 38 |
| 6.5.4 | Connecting the Stand-Alone Grid or Multicluster-Box 6 / 36 | 38 |
| 6.5.5 | Connection of Multicluster-Box 12 (MC-Box-12.3-20) | 40 |
| 6.5.5.1 | Connecting the AC Power Cable of the Multicluster-Box 12..... | 40 |
| 6.5.5.2 | Connecting the Control Cable of the Multicluster-Box 12 | 40 |
| 6.5.5.3 | Connecting the Measuring Cable of the Multicluster-Box 12..... | 41 |
| 6.5.6 | Connecting the Generator in an Off-Grid System | 42 |
| 6.5.7 | Communication Connection | 43 |
| 6.5.7.1 | Connecting the Communication Product via Speedwire | 43 |
| 6.5.7.2 | Connecting the Data Cable of the Lithium-Ion Batteries | 43 |
| 6.5.7.3 | Connecting the Data Cable for the Internal Communication of the Cluster..... | 44 |
| 6.5.7.4 | Connecting the Data Cable of the Multicluster-Box | 45 |
| 6.5.7.5 | Connecting Control and Measuring Cables of the Multicluster-Box | 45 |

| | | |
|----------|--|-----------|
| 6.5.7.6 | Connecting the Data Cables for Multicluster Communication..... | 46 |
| 6.5.8 | Connecting the Battery Temperature Sensor..... | 47 |
| 6.5.9 | Connecting the Battery Current Sensor in the Off-Grid System..... | 48 |
| 6.5.10 | Connecting the Control Cable for Autostart Generators..... | 50 |
| 6.5.11 | Connecting a Signaler for Generators Without an Autostart Function..... | 51 |
| 6.5.12 | Connecting Load-Shedding Contactors..... | 52 |
| 6.5.13 | Connecting the Time Control for External Processes..... | 54 |
| 6.5.14 | Connecting Message Devices for Operating States and Warning Messages..... | 55 |
| 6.5.15 | Connecting the Battery Room Fan..... | 56 |
| 6.5.16 | Connecting the Electrolyte Pump for the Battery..... | 57 |
| 6.5.17 | Connecting the Signal Cable of the External Generator Request..... | 58 |
| 6.6 | Connecting the Cables..... | 59 |
| 6.6.1 | Connecting the DC Power Cable..... | 59 |
| 6.6.2 | Connecting the AC Power Cable..... | 62 |
| 6.6.3 | Connecting the Grounding Conductor..... | 63 |
| 6.6.4 | Connecting the Data Cable..... | 64 |
| 6.6.5 | Connecting Relay 1 and Relay 2..... | 65 |
| 6.6.6 | Connecting BatVtgOut, DigIn, BatTMP and BatCur..... | 66 |
| 6.6.7 | Connecting ExtVtg..... | 67 |
| 6.7 | Checking the Wiring..... | 68 |
| 6.8 | Sealing and Closing the Sunny Island..... | 72 |
| 6.9 | Inserting the Fuse Links in the Fuse Switch-Disconnecter..... | 73 |
| 7 | Commissioning..... | 74 |
| 7.1 | Commissioning Procedure..... | 74 |
| 7.2 | Performing Basic Configuration of the Installation Assistant..... | 75 |
| 7.3 | Commissioning the Inverter..... | 75 |
| 7.4 | Configuring the Country Data Set..... | 76 |
| 7.5 | Changing Thresholds for Systems for Increased Self-Consumption..... | 77 |
| 7.6 | "Battery Management"..... | 77 |
| 7.6.1 | Safety When Setting the Battery Management Parameters..... | 77 |
| 7.6.2 | Adjusting the Battery Management to the Battery..... | 77 |
| 7.6.3 | Changing the Battery Usage Through Battery-Backup Systems without Increased Self-Consumption..... | 78 |
| 7.6.4 | Battery Usage through Systems for Increased Self-Consumption..... | 80 |
| 7.6.4.1 | Seasonal Adjustment of the Battery Usage..... | 80 |
| 7.6.4.2 | Changing the Battery Usage Through Systems for Increased Self-Consumption Without a Battery Backup Grid..... | 81 |
| 7.6.4.3 | Changing the Battery Usage through Battery-Backup Systems with Increased Self-Consumption..... | 84 |
| 7.6.5 | Changing the Battery Protection Mode in Off-Grid Systems..... | 88 |
| 7.6.6 | Configuring the Resistance of the Battery Cable..... | 89 |
| 7.6.7 | Setting the Control of the Battery Room Fan..... | 90 |
| 7.7 | Energy management..... | 90 |
| 7.7.1 | Setting Load Shedding in a Multicluster System..... | 90 |
| 7.7.2 | Setting One-Level Load Shedding..... | 91 |
| 7.7.3 | Setting Two-Level Load Shedding..... | 91 |
| 7.7.4 | Setting Time-Dependent One-Level Load Shedding..... | 92 |
| 7.7.5 | Setting Time-Dependent Two-Level Load Shedding..... | 94 |
| 7.8 | Generator Management..... | 96 |
| 7.8.1 | Configuration of the Thresholds for Generator Connection..... | 96 |
| 7.8.1.1 | Changing the Current Thresholds for the Generator..... | 96 |
| 7.8.1.2 | Changing the Voltage Thresholds for the Generator..... | 97 |

| | | |
|-----------|--|------------|
| 7.8.1.3 | Changing the Frequency Thresholds of the Generator Voltage | 97 |
| 7.8.1.4 | Changing the Permitted Reverse Power in the Generator | 97 |
| 7.8.1.5 | Configuring the Current Limit for the Generator Depending on the Frequency | 98 |
| 7.8.2 | Changing the Type of the Generator Interface | 99 |
| 7.8.3 | Configuring Generator Run Times | 99 |
| 7.8.3.1 | Changing the Warm-Up Time for the Generator | 99 |
| 7.8.3.2 | Changing the Minimum Run Time for the Generator | 99 |
| 7.8.3.3 | Changing the Power-Down Time for the Generator | 100 |
| 7.8.3.4 | Changing the Minimum Stop Time for the Generator | 100 |
| 7.8.4 | Configuring the Generator Request | 100 |
| 7.8.4.1 | Changing the Automatic Generator Operation | 100 |
| 7.8.4.2 | Changing a State-Of-Charge-Dependent Generator Request | 100 |
| 7.8.4.3 | Setting a Time-Dependent Generator Request | 101 |
| 7.8.4.4 | Configuring the Load-Dependent Generator Request | 103 |
| 7.8.4.5 | Time-Controlled Generator Requesting | 103 |
| 7.8.4.6 | Changing the Generator Request via the Charging Process of the Battery | 104 |
| 7.8.4.7 | Setting an External Generator Request | 104 |
| 7.8.5 | Configuring the Procedure in the Event of a Generator False Start | 105 |
| 7.9 | Off-Grid System | 105 |
| 7.9.1 | Commissioning the Battery Current Sensor in Off-Grid Systems | 105 |
| 7.9.2 | Changing the Automatic Frequency Synchronization in Off-Grid Systems | 107 |
| 7.10 | Multifunction Relay | 107 |
| 7.10.1 | Setting the Time Control | 107 |
| 7.10.2 | Setting the Functions of the Multifunction Relays | 108 |
| 7.11 | Complete Commissioning. | 109 |
| 8 | Using the Inverter User Interface | 110 |
| 8.1 | Establishing a connection to the user interface | 110 |
| 8.1.1 | Establishing a direct connection via WLAN | 110 |
| 8.1.2 | Establishing a Direct Connection via Ethernet | 111 |
| 8.1.3 | Establishing a Connection via Ethernet in the local network | 112 |
| 8.2 | Logging In and Out of the User Interface | 112 |
| 8.3 | Start Page Design of the User Interface | 114 |
| 8.4 | Changing the Password | 116 |
| 8.5 | Forgotten Password | 117 |
| 9 | Configuration of the Inverter | 118 |
| 9.1 | Starting the Installation Assistant | 118 |
| 9.2 | Changing Operating Parameters | 119 |
| 9.3 | Setting Time-Controlled Inverter Operation in Off-Grid Systems | 119 |
| 9.4 | Activate WPS Function | 120 |
| 9.5 | Switching WLAN On and Off | 120 |
| 9.6 | Configuring the Energy Meter | 121 |
| 9.7 | Configuring the Modbus Function | 121 |
| 9.8 | Supplementary Information | 122 |
| 9.8.1 | Determining the Battery Capacity | 122 |
| 9.8.2 | Setting Time-Dependent Functions | 123 |
| 9.8.3 | Setting Time-Controlled Functions | 123 |
| 10 | Starting and Stopping the System | 124 |
| 10.1 | Switching on the Sunny Island | 124 |
| 10.2 | Starting the System | 124 |

| | | |
|-----------|--|------------|
| 10.3 | Stopping the System..... | 125 |
| 10.4 | Switching Off the Sunny Island..... | 125 |
| 10.5 | Tripping the Emergency Disconnection of the System..... | 126 |
| 11 | Data Storage and Firmware Update..... | 127 |
| 11.1 | Viewing Event Messages or Instantaneous Values | 127 |
| 11.2 | Exporting Event Messages..... | 127 |
| 11.3 | Exporting Parameters | 127 |
| 11.4 | Updating the Firmware | 127 |
| 11.5 | Saving the Configuration in a File | 128 |
| 11.6 | Adopting a Configuration from a File | 128 |
| 12 | Manually Controlling the Generator..... | 130 |
| 12.1 | Starting the Generator via the User Interface..... | 130 |
| 12.2 | Stopping the Generator via the User Interface..... | 130 |
| 12.3 | Starting the Generator without Autostart Function | 130 |
| 12.4 | Stopping the Generator without Autostart Function | 131 |
| 13 | Disconnecting the Sunny Island from Voltage Sources | 132 |
| 14 | Cleaning and Maintenance..... | 133 |
| 14.1 | Cleaning and Checking the Sunny Island Inverter Enclosure | 133 |
| 14.2 | Checking the Function | 133 |
| 14.3 | Checking the Connections | 133 |
| 14.4 | Cleaning the Fans..... | 134 |
| 14.5 | Performing a Manual Equalization Charge in the Off-Grid System..... | 136 |
| 14.6 | Checking and Maintaining the Battery | 136 |
| 14.7 | Charging the Battery After Automatic Shutdown in Off-Grid Systems (Emergency Charge Mode)..... | 137 |
| 14.8 | Changing Slave Addresses in a Cluster..... | 139 |
| 14.9 | Replacing the Battery | 140 |
| 14.10 | Replacing the Micro SD Card | 141 |
| 14.11 | Opening the Inverter | 142 |
| 14.12 | Recommissioning the Inverter..... | 143 |
| 15 | Troubleshooting..... | 145 |
| 15.1 | Sunny Island Inverter Behavior Under Fault Conditions..... | 145 |
| 15.2 | Event Messages..... | 145 |
| 15.3 | Acknowledge Errors | 174 |
| 15.4 | Frequently Asked Questions (FAQs) | 175 |
| 15.4.1 | Questions Regarding the Sunny Island..... | 175 |
| 15.4.2 | Questions Regarding the Battery | 175 |
| 15.4.3 | Questions Regarding the Generator..... | 176 |
| 15.4.4 | Questions Regarding Multicluster Systems..... | 177 |
| 16 | Decommissioning the Sunny Island..... | 178 |
| 17 | Technical Data | 180 |
| 17.1 | AC1 Connection for Stand-Alone Grid..... | 180 |
| 17.2 | AC2 Connection for Utility Grid and Generator (External Energy Source) | 181 |
| 17.3 | DC Connection for Battery..... | 181 |
| 17.4 | Efficiency | 182 |

| | | |
|-----------|--|------------|
| 17.5 | Sunny Island 4.4M Efficiency Profile..... | 183 |
| 17.6 | Sunny Island 6.0H Efficiency Profile | 184 |
| 17.7 | Sunny Island 8.0H Efficiency Profile | 185 |
| 17.8 | Energy Consumption in No-Load Operation and Standby | 185 |
| 17.9 | Noise Emission..... | 185 |
| 17.10 | Grid Configuration | 185 |
| 17.11 | Protective Devices..... | 185 |
| 17.12 | Equipment | 186 |
| 17.13 | Data Storage Capacity | 186 |
| 17.14 | DC Load Limitation Curve of the Multifunction Relays | 187 |
| 17.15 | General Data..... | 187 |
| 18 | Spare Parts and Accessories | 188 |
| 19 | Contact | 189 |
| 20 | EU Declaration of Conformity | 191 |

1 Information on this Document

1.1 Validity

This document is valid for the following device types:

- SI4.4M-12 (Sunny Island 4.4M)
- SI6.0H-12 (Sunny Island 6.0H)
- SI8.0H-12 (Sunny Island 8.0H)

1.2 Target Group

This document is intended for qualified persons and operators. Only qualified persons are allowed to perform the activities marked in this document with a warning symbol and the caption "Qualified person". Tasks that do not require any particular qualification are not marked and can also be performed by operators. Qualified persons must have the following skills:



- Knowledge of how an inverter works and is operated
- Knowledge of how batteries work and are operated
- Training in the installation and commissioning of electrical devices and installations
- Knowledge of the applicable standards and directives
- Knowledge of and compliance with this document and all safety information
- Knowledge of and compliance with the documents of the battery manufacturer with all safety information





1.3 Additional Information

Links to additional information can be found at www.SMA-Solar.com:

| Document title | Document type |
|--|--------------------------------------|
| "Battery Management in Off-Grid Systems" | Technology Brochure 6 |
| "Battery Management" | Technical information |
| "Grounding in Off-Grid Systems" | Technical information |
| "Design of Off-Grid Systems with Sunny Island Devices" | Planning guidelines |
| "SMA Flexible Storage System with Battery Backup Function" | Planning guidelines |
| "SMA Smart Home" | Planning guidelines |
| "Multicluster Systems with Stand-Alone Grid or Increased Self-Consumption and Battery-Backup Function" | Installation – Quick Reference Guide |

1.4 Symbols

| Symbol | Explanation |
|--|---|
|  DANGER | Indicates a hazardous situation which, if not avoided, will result in death or serious injury |
|  WARNING | Indicates a hazardous situation which, if not avoided, can result in death or serious injury |
|  CAUTION | Indicates a hazardous situation which, if not avoided, can result in minor or moderate injury |
| NOTICE | Indicates a situation which, if not avoided, can result in property damage |

| Symbol | Explanation |
|---|--|
|  QUALIFIED PERSON | Information advising that the following section contains activities that may be performed only by qualified persons. |
|  | This information is relevant for systems which are to be operated in parallel with utility grid. (e.g. SMA Flexible Storage System). |
|  | Content is relevant for off-grid systems. |
|  | Information that is important for a specific topic or goal, but is not safety-relevant |
| <input type="checkbox"/> | Indicates a requirement for meeting a specific goal |
| <input checked="" type="checkbox"/> | Desired result |
|  | A problem that might occur |

1.5 Typographies

| Typography | Use | Example |
|-------------|---|---|
| bold | <ul style="list-style-type: none"> Terminals Slots Parameters Elements on the user interface Elements to be selected Elements to be entered | <ul style="list-style-type: none"> The value can be found in the field Energy. Select Settings. Enter 10 in the field Minutes. |
| > | <ul style="list-style-type: none"> Connects several elements to be selected | <ul style="list-style-type: none"> Select Settings > Date. |
| [Button] | <ul style="list-style-type: none"> Button to be selected or pressed | <ul style="list-style-type: none"> Select [Next]. |

1.6 Nomenclature

| Complete designation | Designation in this document |
|--|------------------------------|
| Off-grid system, battery-backup system, system for increased self-consumption | System |
| Sunny Places, Sunny Boy, Sunny Mini Central, Sunny Tripower | PV inverter |
| Sunny Portal, Sunny Home Manager, SMA Cluster Controller | Communication product |
| Grid failure or deviation from the country-specific thresholds for voltage and frequency | Grid failure |

| Complete designation | Designation in this document |
|--|-------------------------------------|
| Automatic transfer switch with battery-backup function | Automatic transfer switch |
| Grid-forming generators such as electric generators or utility grids | External energy sources |

2 Safety

2.1 Intended Use

The Sunny Island is a battery inverter that controls the electrical energy balance in an off-grid system, in a system for increased self-consumption or in a battery-backup system.

The product is for use in weather-protected outdoor areas and in indoor areas.

The product must only be used as stationary equipment.

The grid configuration of the utility grid must be a TN or TT system. Cables with copper conductors must be used for the installation.

Device type SI4.4M-12 must not be used for single-phase single cluster systems and not for three-phase multi cluster systems (see system description "Off-Grid Systems").

The product is not suitable for supplying life-sustaining medical devices. A power outage must not lead to personal injury.

Loads connected to the Sunny Island must have an CE, RCM or UL identification label.

The loads may temporarily overload the Sunny Island. Therefore, only circuit breakers that can trigger the Sunny Island at maximum may be used in off-grid systems and battery-backup systems.

The maximum output power of the AC sources must be observed in off-grid systems and battery-backup systems (see Section 17 "Technical Data", page 180). The powers of the individual Sunny Island inverters are added to yield the maximum total power.

The entire battery voltage range must be completely within the permissible DC input voltage range of the Sunny Island. The maximum permissible DC input voltage of the Sunny Island must not be exceeded. A battery fuse must be installed between the battery and the Sunny Island.

With lead-acid batteries, the battery room must be ventilated in accordance with the requirements of the battery manufacturer and with the locally applicable standards and directives (see documentation of the battery manufacturer).

The following conditions must be satisfied for lithium-ion batteries:

- The lithium-ion battery must comply with the locally applicable standards and directives and must be intrinsically safe.
- The battery management of the lithium-ion battery used must be compatible with the Sunny Island (see the technical information at "List of Approved Batteries").
- Applicable for off-grid systems and battery-backup systems: the lithium-ion battery must be able to supply sufficient current at the maximum output power of the Sunny Island (see Section 17 "Technical Data", page 180).

An DC supply grid may not be established with the Sunny Island.

The multifunction relays of the Sunny Island are not suitable for controlling safety-relevant functions which can endanger persons in the event of a malfunction in the multifunction relays.

Use this product only in accordance with the information provided in the enclosed documentation and with the locally applicable standards and directives. Any other application may cause personal injury or property damage.

Alterations to the product, e.g. changes or modifications, are only permitted with the express written permission of SMA Solar Technology AG. Unauthorized alterations will void guarantee and warranty claims and in most cases terminate the operating license. SMA Solar Technology AG shall not be held liable for any damage caused by such changes.

Any use of the product other than that described in the Intended Use section does not qualify as the intended use.

The enclosed documentation is an integral part of this product. Keep the documentation in a convenient place for future reference and observe all instructions contained therein.

The type label must remain permanently attached to the product.

2.2 Safety Information

This section contains safety information that must be observed at all times when working on or with the product.

To prevent personal injury and property damage and to ensure long-term operation of the product, read this section carefully and observe all safety information at all times.

DANGER

Danger to life from electric shock due to live voltage

High voltages are present in the live components of the inverter when in operation. Touching live components results in death or serious injury due to electric shock.

- Wear suitable personal protective equipment for all work on the product.
- Do not touch any live components.
- Observe all warning messages on the inverter and in the documentation.
- Observe all safety information of the battery manufacturer.
- Switch off or disconnect the following components from voltage sources in the following order before carrying out any work:
 - Sunny Island
 - The circuit breakers of the Sunny Island, the control and measurement voltages
 - All circuit breakers and load-break switches of the connected AC sources
 - Load-break switch of the battery fuse
- Ensure that no disconnected devices can be reconnected.
- After disconnecting the Sunny Island from voltage sources, wait at least 15 minutes for the capacitors to discharge completely before opening the doors.
- Before carrying out any work make sure that all devices are completely voltage-free.
- Cover or isolate any adjacent live components.

DANGER

Danger to life due to electric shock

Overvoltages (e. g. in the case of a flash of lightning) can be further conducted into the building and to other connected devices in the same network via network cables or other data cables if there is no overvoltage protection.

- Ensure that all devices in the same network and the battery are integrated in the existing overvoltage protection.
- When laying the network cables or other data cables outdoors, attention must be given to suitable overvoltage protection at the cable transition from the inverter or the battery outdoors to the inside of a building.

⚠ DANGER**Danger to life due to electric shock caused by incorrect connection to the grounding conductor terminals**

Only the grounding conductors of the AC power cable may be connected to the grounding conductor terminals of the inverter. When connecting the battery grounding to the grounding conductor terminals, life-threatening voltages might be present on the enclosure of the inverter

- Have the inverter and the battery mounted, installed and commissioned only by qualified persons with the appropriate skills.
- Observe all safety information of the battery manufacturer.
- Ground the battery according to the battery manufacturer's requirements.
- If the locally applicable standards and directives require battery grounding, connect the battery grounding to the grounding busbar in the distributor.

⚠ WARNING**Danger to life from electric shock due to circuit breakers that cannot be tripped**

In an off-grid system and battery-backup system, only the circuit breakers that can be tripped by the Sunny Island can be tripped in the event of a grid failure. Circuit breakers with a higher operating current cannot be tripped. Under fault conditions, a voltage that poses a danger to life may be present on accessible parts for several seconds.

- Check if a circuit breaker has a higher trip characteristic than the following circuit breakers which can be tripped:
 - SI4.4M-12: circuit breaker with trip characteristic B6 (B6A)
 - SI6.0H-12 and SI8.0H-12: circuit breaker with trip characteristic B16 (B16A) or circuit breaker with trip characteristic C6 (C6A)
- If a circuit breaker has a higher trip characteristic than the specified circuit breakers that can be tripped, you should also install a residual-current device of type A.

⚠ WARNING**Danger to life from electric shock due to overvoltages**

Overvoltages of up to 1500 V can occur in the stand-alone grid and in the battery-backup grid. If the connected loads have not been designed for these overvoltages, a voltage that poses a danger to life may be present on accessible parts for several seconds.

- Only connect loads that have a CE, RCM or UL designation. Loads with a CE, RCM or UL designation are designed for overvoltages of up to 1500 V.
- Operate the loads only when they are technically faultless and in an operationally safe state.
- Check the loads regularly for visible damage.

⚠ WARNING**Danger to life from electric shock due to damaged inverter**

Operating a damaged inverter can lead to hazardous situations that can result in death or serious injuries due to electric shock.

- Only use the inverter when it is technically faultless and in an operationally safe state.
- Check the inverter regularly for visible damage.
- Make sure that all external safety equipment is freely accessible at all times.
- Make sure that all safety equipment is in good working order at any time.

⚠ WARNING**Risk of crushing injuries due to moving PV array parts**

A generator can be started automatically by the Sunny Island. Moving parts in the PV array can crush or sever body parts.

- Operate the generator only with the specified safety equipment.
- Carry out all work on the generator in accordance with the manufacturer's specifications.

⚠ CAUTION**Risk of burns due to short-circuit currents on the disconnected inverter**

The capacitors in the DC input area of the inverter store energy. After the battery is isolated from the inverter, battery voltage is still temporarily present at the DC terminal. A short circuit at the DC terminal of the inverter can lead to burns and may damage the inverter.

- Wait 15 minutes before performing any work at the DC terminal or on the DC cables. This allows the capacitors to discharge.

⚠ CAUTION**Risk of burns due to hot enclosure parts**

Some parts of the enclosure can get hot during operation.

- Mount the inverter in such a way that it cannot be touched inadvertently during operation.

NOTICE**Damage to the product due to sand, dust or moisture penetration**

Sand, dust or moisture penetration can damage the inverter or impair its functionality.

- Do not open the inverter during a sandstorm, precipitation or when humidity exceeds 95%.
- Only perform maintenance work on the inverter when the environment is dry and free of dust.

NOTICE**Damage to the inverter due to electrostatic discharge**

Touching electronic components can cause damage to or destroy the inverter through electrostatic discharge.

- Ground yourself before touching any component.

NOTICE**Damage to seals on the enclosure lids in subfreezing conditions**

If you open the enclosure lid when temperatures are below freezing, the enclosure lid seal could be damaged. This can lead to moisture entering the inverter.

- Only open the enclosure lid if the ambient temperature is not below -5°C
- If a layer of ice has formed on the seal of the lid when temperatures are below freezing, remove it prior to opening the enclosure lid (e.g. by melting the ice with warm air). Observe the applicable safety regulations.

2.3 Battery Safety Information

This section contains safety information that must be observed at all times when working on or with batteries.

To prevent personal injury or property damage and to ensure long-term operation of the batteries, read this section carefully and observe all safety information at all times.

⚠ WARNING**Danger to life due to incompatible lithium-ion battery**

An incompatible lithium-ion battery can lead to a fire or an explosion. With incompatible lithium-ion batteries, it is not ensured that battery management is intrinsically safe and will protect the battery.

- Ensure that the lithium-ion batteries are approved for use with the Sunny Island (see technical information "List of Approved Batteries" at www.SMA-Solar.com).
- If no lithium-ion batteries approved for the inverter can be used, lead-acid batteries can be used.
- Verify that the battery complies with locally applicable standards and directives and is intrinsically safe.

⚠ WARNING**Danger to life due to explosive gases**

Explosive gases may escape from the battery and cause an explosion.

- Protect the battery environment from open flames, embers and sparks.
- Install, operate and maintain the battery in accordance with the manufacturer's specifications.
- Do not burn the battery and do not heat it beyond the permitted temperature.
- Additional measures for lead-acid batteries: Ensure that the battery room is sufficiently ventilated.

⚠ WARNING**Chemical burns due to battery electrolyte**

If handled inappropriately, battery electrolyte can leak from the battery and cause irritation to the eyes, respiratory system and skin.

- Install, operate, maintain and dispose of the battery according to the manufacturer's specifications.
- Whenever working on the battery, wear suitable personal protective equipment such as rubber gloves, an apron, rubber boots and goggles.
- Rinse acid splashes thoroughly for a long time with clear water, and consult a doctor immediately.
- If acid fumes have been inhaled, consult a doctor immediately.

⚠ WARNING**Risk of burns due to flashes**

Short-circuit currents in the battery can cause heat build-up and flashes.

- Remove watches, rings and other metal objects prior to carrying out any work on the battery.
- Use insulated tools for all work on the battery.
- Do not place tools or metal parts on the battery.

⚠ CAUTION**Risk of burns due to hot battery components**

Improper battery connection may result in excessively high transition resistances. Excessive transition resistances give rise to localized heat build-up.

- Ensure that all pole connectors are connected with the connecting torque specified by the battery manufacturer.
- Ensure that all DC cables are connected with the connecting torque specified by the battery manufacturer.

NOTICE**Damage to the battery due to incorrect settings**

The set battery parameters influence the charging behavior of the inverter. The battery can be damaged by incorrect settings of the battery type, nominal voltage and capacity parameters.

- Set the correct battery type as well as the correct values for nominal voltage and battery capacity when configuring.
- Ensure that the values recommended by the manufacturer are set for the battery (refer to the technical data of the battery in the manufacturer documentation).

NOTICE**Permanent damage to the battery due to improper handling**

Improper set-up and maintenance of the battery can cause it to become permanently damaged. Logs can help to determine the cause.

- Comply with all requirements of the battery manufacturer with regard to mounting location.
- Check and log the status of the battery before performing maintenance work.
Useful hint: Many battery manufacturers provide suitable logs.
 - Check the battery for visible damage and log.
 - Measure and log the fill level and acid density of FLA batteries.
 - In the case of lead-acid batteries, measure and log the voltages of the individual cells.
 - Perform and log the test routines required by the battery manufacturer.

2.4 Battery-Backup System Safety Information

i Wiring and connection of automatic transfer switches for single-phase or three-phase battery-backup systems

- Do not bridge the neutral conductors of connections **X1** to **X5** in the automatic transfer switch. If the neutral conductor connections are bridged, residual-current devices could trip accidentally.
- Label the equipment and devices of the automatic transfer switch in accordance with the schematic diagrams. This will facilitate installation, commissioning and assistance in case servicing is required.

i **Connection of automatic transfer switches for single-phase battery-backup systems**

In single-phase battery-backup systems, only the line conductor of the Sunny Island that is connected to the circuit breaker **F1** of the automatic transfer switch is monitored for grid failure. If terminal **AC2 Gen/Grid L** is connected to another line conductor, the battery-backup system is not able to synchronize with the utility grid following a grid failure.

- With single-phase battery-backup systems, connect circuit breaker **F1** and terminal **AC2 Gen/Grid L** of the Sunny Island to the same line conductor, e.g. to L1 (for a single-phase battery-backup system with an all-pole disconnection function).
- Connect the PV inverter and the Sunny Island to the same line conductor if possible. This way, in the event of grid failure, the PV inverters are supplied with voltage directly and then can feed in even if phase coupling is deactivated.

3 Scope of Delivery

Check the scope of delivery for completeness and any externally visible damage. Contact your distributor if the scope of delivery is incomplete or damaged.

Sunny Island

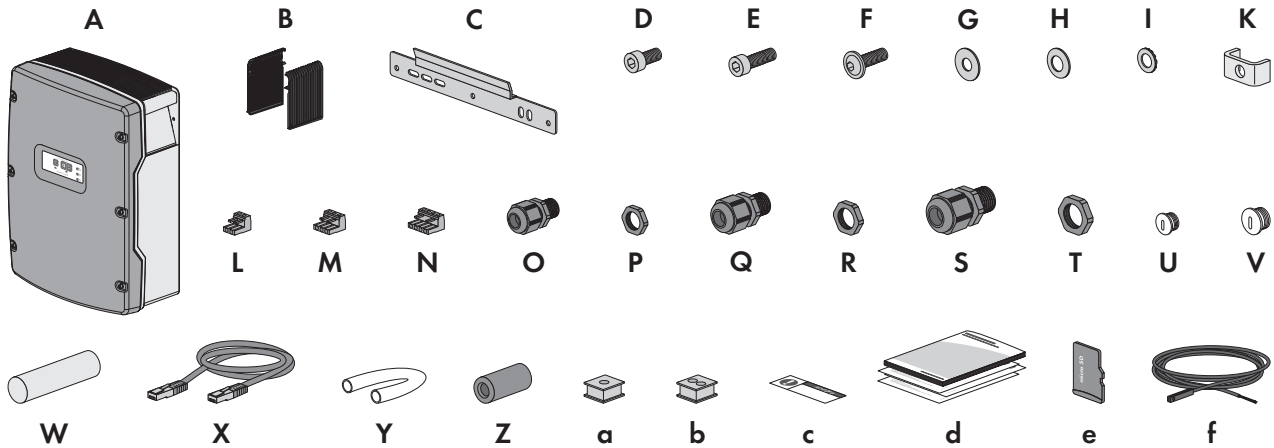
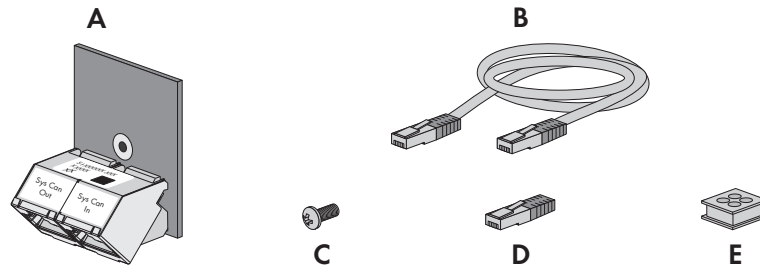

Figure 1: Components included in the scope of delivery

| Position | Quantity | Designation | Position | Quantity | Designation |
|----------|----------|--------------------------------------|----------|----------|-------------------------------------|
| A | 1 | Sunny Island | S | 2 | Cable gland M32 |
| B | 2 | Ventilation grid | T | 2 | Counter nut for cable gland M32 |
| C | 1 | Wall mounting bracket | U | 1 | Filler plug M20 |
| D | 2 | Hexagon socket screw M6x10 | V | 1 | Filler plug M25 |
| E | 2 | Hexagon socket screw M6x16 | W | 1 | Putty in a separate accessory kit |
| F | 2 | Pan head screw with hex socket M8x20 | X | 1 | Black CAT5e data cable, 2 m |
| G | 2 | Fender washer M8 | Y | 2 | Silicon tube 10 mm x 500 mm |
| H | 2 | Spring washer M8 | Z | 3 | Ferrite |
| I | 2 | Conical spring washer M6 | a | 1 | Cable support sleeve for one cable |
| K | 1 | Clamping bracket | b | 2 | Cable support sleeve for two cables |
| L | 1 | 2-pole connecting terminal plate | c | 1 | Label "VDE 0126-1-1" |
| M | 2 | 3-pole connecting terminal plate | d | 1 | Quick Reference Guide |
| N | 2 | 4-pole connecting terminal plate | | | |
| O | 1 | Cable gland M20 | | | |
| P | 1 | Counter nut for cable gland M20 | | | |

| Position | Quantity | Designation | Position | Quantity | Designation |
|----------|----------|---------------------------------|----------|----------|---------------------------------------|
| Q | 2 | Cable gland M25 | e | 1 | Micro SD card (optional) |
| R | 2 | Counter nut for cable gland M25 | f | 1 | Battery temperature sensor (optional) |

Communication for Multiclustet System Order Option



| Position | Quantity | Designation |
|----------|----------|--|
| A | 1 | SI-SYSCAN.BGx*, installed in the master at the factory |
| B | 1 | Yellow CAT5e data cable, 5 m |
| C | 1 | Screw, installed in the Sunny Island at the factory |
| D | 1 | Terminator, plugged into SI-SYSCAN.BGx at the factory |
| E | 1 | Cable support sleeve for four cables |

* CAN communication interface

4 Product Description

4.1 Sunny Island

The Sunny Island is a battery inverter that controls the electrical energy balance in an off-grid system, in a system for increased self-consumption or in a battery-backup system.

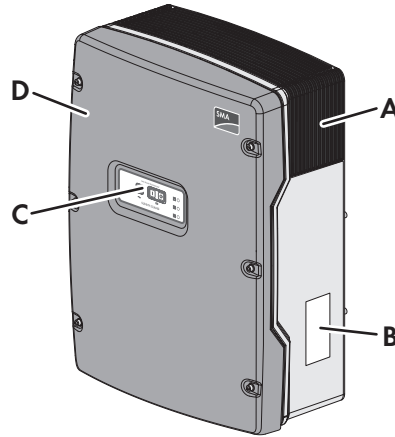













Figure 2: Design of the Sunny Island inverter

| Position | Designation |
|----------|---|
| A | Ventilation grid |
| B | Type label The type label uniquely identifies the inverter. You will require the information on the type label to use the product safely and when seeking customer support from Service. The type label must remain permanently attached to the product. You will find the following information on the type label: <ul style="list-style-type: none"> • Address of SMA Solar Technology AG • Device type (Model) • Serial number (Serial No.) • Device-specific characteristics • Identification key (PIC) for registration in Sunny Portal • Registration ID (RID) for registration in Sunny Portal • WLAN password WPA2-PSK (WiFi Protected Access 2 - Preshared Key) for direct connection to the inverter via WLAN |
| C | Control panel |
| D | Enclosure lid |

Symbols on the Inverter and on the Type Label

| Symbol | Explanation |
|---|---|
|  | Danger to life due to electric shock The product operates at high voltages. Prior to performing any work on the product, disconnect the product from voltage sources. All work on the product must be carried out by qualified persons only. |

| Symbol | Explanation |
|--|--|
|  | Risk of burns due to hot surfaces The product can get hot during operation. Avoid contact during operation. Prior to performing any work on the product, allow the product to cool down sufficiently. |
|  | Observe the documentation Observe all documentation supplied with the product. |
|  | Alternating current |
|  | Direct current |
|  | Transformer The product has a transformer. |
|  | WEEE designation Do not dispose of the product together with the household waste but in accordance with the disposal regulations for electronic waste applicable at the installation site. |
|  | CE marking The product complies with the requirements of the applicable EU directives. |
|  | Grounding conductor This symbol indicates the position for connecting a grounding conductor. |
|  IP54 | Degree of protection IP54 The product is protected against interior dust deposits and splashing water from all angles. |
|  | RCM (Regulatory Compliance Mark) The product complies with the requirements of the applicable Australian standards. |

4.2 Interfaces and Functions

The inverter can be equipped or retrofitted with the following interfaces and functions:

User interface for the monitoring and configuration of the inverter

The inverter is standard-equipped with an integrated web server, which provides a user interface for configuring and monitoring the inverter. The inverter user interface can be called up via the web browser if there is an existing WLAN or Ethernet connection to a computer, tablet PC or smartphone.

SMA Speedwire

The inverter is equipped with SMA Speedwire as standard. SMA Speedwire is a type of communication based on the Ethernet standard. This enables inverter-optimized 10 or 100 Mbit data transmission between Speedwire devices in PV systems and the user interface of the inverter.

SMA Webconnect

The inverter is equipped with a Webconnect function as standard. The Webconnect function enables direct data transmission between the inverters of a small-scale system and the Internet portal Sunny Portal without any additional communication device and for a maximum of 4 inverters per Sunny Portal system. If there is an existing WLAN or Ethernet connection, you can directly access your Sunny Portal system via the web browser on the computer, tablet PC or smartphone.

WLAN

The inverter is equipped with a WLAN interface as standard. The inverter is delivered with the WLAN interface activated as standard. If you do not want to use WLAN, you can deactivate the WLAN interface.

In addition, the inverter has a WPS (WiFi Protected Setup) function. The WPS function is for automatically connecting the inverter to a device in the same network as the inverter (e.g. router, computer, tablet PC or smartphone).

i Limited function in the event of frost

The integrated WLAN interface is only designed for temperatures down to -20°C.

- Deactivate the WLAN interface at low temperatures (see Section 9.5 "Switching WLAN On and Off", page 120).

i Limited range

The WLAN interface integrated in the inverter has a limited range of 5 m.

- Take this range into consideration when establishing the WLAN connection.

Multicluster Communication

In a multicluster system, the masters of the clusters must communicate with each other via a separate CAN bus. The Multicluster data module SI-SYSCAN.BGx must be installed in each master for this multicluster communication. The interface slot SISYSCAN is for connecting the Multicluster data module SI-SYSCAN.BGx.

If the Sunny Islands are ordered with the communication interface multicluster CAN, the masters are delivered with multicluster data modules.

Multicluster communication only functions with the device types SI6.0H-12 und SI8.0H-12.

Data Storage

Event messages and instantaneous values are saved in the Sunny Island. This data can be evaluated and thus the operating processes in the Sunny Island system can be traced. From this, for example, parameter settings can be derived that will e.g. increase the self-consumption of PV energy or the service life of the battery. For SMA Service, this data simplifies the analysis of any errors present and the identification of possible solutions.

The storage capacity of the inverter can be extended with the optional micro SD card. Thus, for example, data can be recorded over longer time periods, enabling extended diagnostics possibilities to be used (see Section 17.13, page 186).

4.3 Control Panel

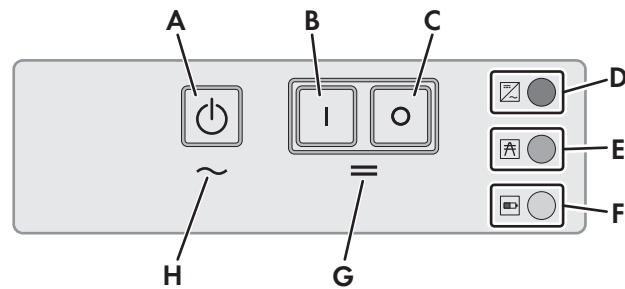

Figure 3: Layout of the control panel

| Position | Symbol | Designation | Status | Explanation |
|-------------------|--|-------------------|-------------------|--|
| A | | Start-stop button | – | By pressing the start-stop button, you can start or stop the system. |
| B | | "On" button | – | Pressing the "On" button will switch the Sunny Island on. The Sunny Island is in standby mode after being switched on. |
| C | | "Off" button | – | Pressing the "Off" button will switch off the Sunny Island. |
| D | | Inverter LED | Not glowing | The Sunny Island is switched off. |
| | | | Glowing green | The Sunny Island is in operation. |
| | | | Glowing orange | The Sunny Island is in standby mode. |
| | | | Glowing red | The Sunny Island switched off due to an error. |
| | | | Flashing quickly* | The Sunny Island is not configured. |
| Flashing slowly** | The Sunny Island is in overnight shutdown. | | | |
| E | | Grid LED | Not glowing | There is no voltage present from the generator or the utility grid. |
| | | | Glowing green | Generator or utility grid is connected. |
| | | | Glowing orange | The Sunny Island is synchronizing the stand-alone grid with the generator or the utility grid. |
| | | | Glowing red | Error at the connection of the generator or the utility grid. |
| F | | Battery LED | Glowing green | The state of charge is more than 50%. |
| | | | Glowing orange | The state of charge is between 50% and 20%. |
| | | | Glowing red | The state of charge is less than 20%. |
| G | | Standby | – | Position of the buttons for switching on and off |
| H | | AC operation | – | Position of the button for starting and stopping operation |

* Flashing at intervals of 0.5 s to 1 s

** Flashing at intervals of 1.5 s to 2 s

4.4 Multifunction Relay

Using two multifunction relays, each Sunny Island can control various functions and can display operating states and warning messages.

In an SMA Flexible Storage System with battery-backup function, the multifunction relays of the master are set permanently.

In multicluster systems with Multicluster-Box 12 (MC-BOX-12.3-20), multifunction relays 1 and 2 in the master of the main cluster and multifunction relay 2 in slave 1 of the main cluster are set permanently.

| Possible function or output | Explanation |
|---|--|
| Control of the tie switch and of the contactors for grounding | In the SMA Flexible Storage System with battery-backup function, the multifunction relays control the contactors for grid coupling and grounding. |
| Switch cycles in the multicluster system | In multicluster systems with Multicluster-Box 12, multifunction relays control different switch cycles in the multicluster system. |
| Controlling PV arrays | The multifunction relay activates if a PV array request is received from the Sunny Island inverter's generator management system. With the multifunction relay, you can control PV arrays with an electrical remote-start function or connect a signal generator for PV arrays with no autostart function (see Section 6.5.10, page 50). |
| Controlling load-shedding contactors | The multifunction relay is activated depending on the state of charge of the battery. Depending on the configuration, you can install a one-level load shedding with one multifunction relay or a two-level load shedding with two multifunction relays. You can also adjust the thresholds for the state of charge of the battery depending on the time of day (see Section 6.5.12, page 52). |
| Time control for external processes | The multifunction relays can be time-controlled (see Section 6.5.13, page 54). |
| Display of operating states and warning messages | Each multifunction relay can display either one event or one warning message (see Section 6.5.14, page 55). |
| Control of a battery-room fan | The multifunction relay is activated when the charging current causes the battery to emit gasses. A connected battery room fan is switched on for at least one hour (see Section 6.5.15, page 56). |
| Control of an electrolyte pump | Depending on the nominal energy throughput, the multifunction relay is activated at least once a day (see Section 6.5.16, page 57). |
| Use of excess energy | In off-grid systems during the constant voltage phase, a multifunction relay is activated and thus controls additional loads that can put any excess energy to good use (see Section , page 000). |

5 Mounting

5.1 Requirements for Mounting

Requirements for the Mounting Location:

WARNING

Danger to life due to fire or explosion

Despite careful construction, electrical devices can cause fires.

- Do not mount the product in areas containing highly flammable materials or gases.
- Do not mount the product in potentially explosive atmospheres.

WARNING

Danger to life due to explosive gases

Explosive gases may escape from the battery and cause an explosion.

- Protect the battery environment from open flames, embers and sparks.
- Install, operate and maintain the battery in accordance with the manufacturer's specifications.
- Do not burn the battery and do not heat it beyond the permitted temperature.
- Additional measures for lead-acid batteries: Ensure that the battery room is sufficiently ventilated.

- The mounting location must be inaccessible to children.
- A solid support surface must be available for mounting, e.g. concrete or masonry. When mounted on drywall or similar materials, the inverter emits audible vibrations during operation which could be perceived as annoying.
- The mounting location must be suitable for the weight and dimensions of the inverter (see Section 17 "Technical Data", page 180).
- The mounting location must not be exposed to direct solar irradiation. Direct solar irradiation can result in the premature aging of the exterior plastic parts of the inverter and direct solar irradiation can cause the inverter to overheat. When becoming too hot, the inverter reduces its power output to avoid overheating.
- The mounting location must be less than 3000 m above Mean Sea Level (MSL). From altitudes of 2000 m above MSL, the power decreases by 0.5% every 100 m.
- The mounting location must not hinder access to disconnection devices.
- The mounting location should be freely and safely accessible at all times without the need for any auxiliary equipment (such as scaffolding or lifting platforms). Non-fulfillment of these criteria may restrict servicing.
- The ambient temperature should be below 40°C to ensure optimum operation.
- Climatic conditions must be met (see Section 17 "Technical Data", page 180).

Permitted and prohibited mounting positions:

- The inverter must only be mounted in one of the permitted positions. This will ensure that no moisture can penetrate the inverter.
- The inverter should be mounted in such way that display messages or LED signals can be read without difficulty and buttons operated.

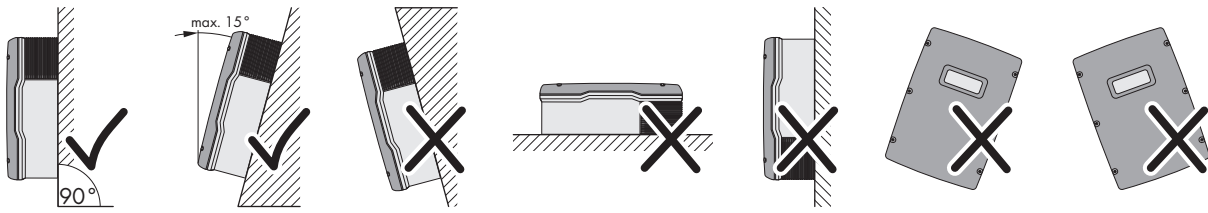

Figure 4: Permitted and prohibited mounting positions

Dimensions for mounting:

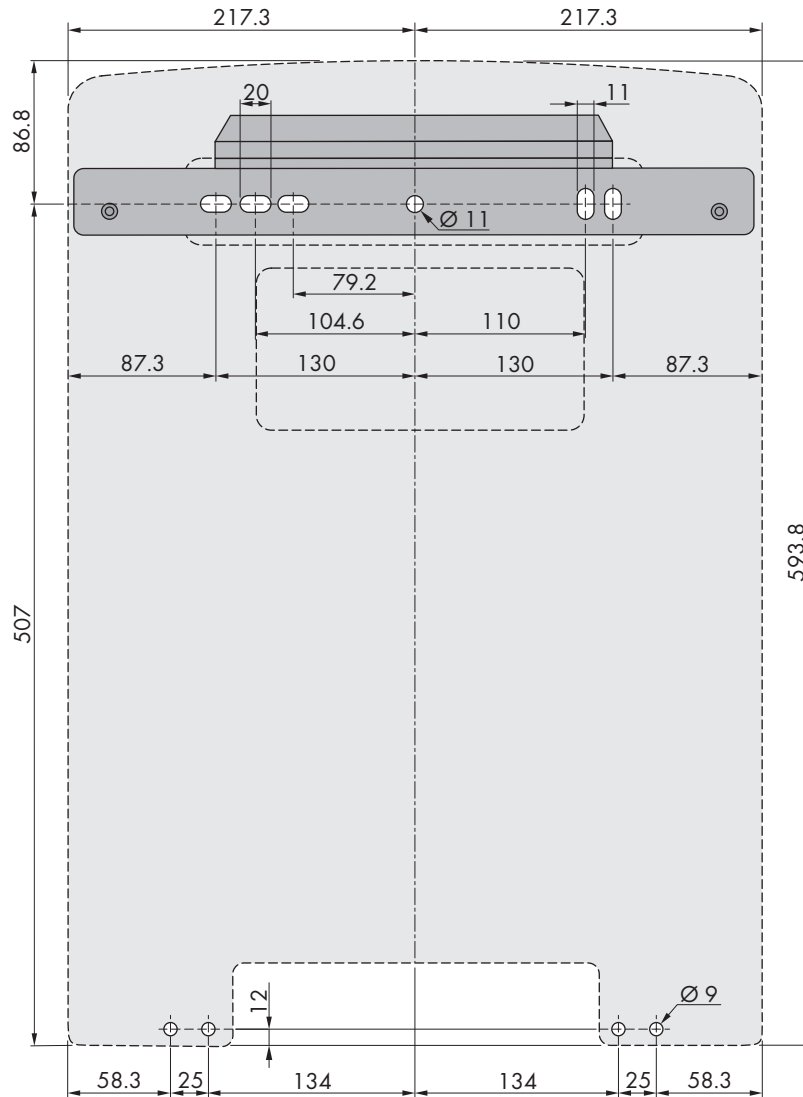

Figure 5: Position of the anchoring points (dimensions in mm)

Recommended clearances:

If you maintain the recommended clearances, adequate heat dissipation will be ensured. Thus, you will prevent power reduction due to excessive temperature.

- Maintain the recommended clearances to walls as well as to other inverters or objects.
- If multiple inverters are mounted in areas with high ambient temperatures, increase the clearances between the inverters and ensure sufficient fresh-air supply.

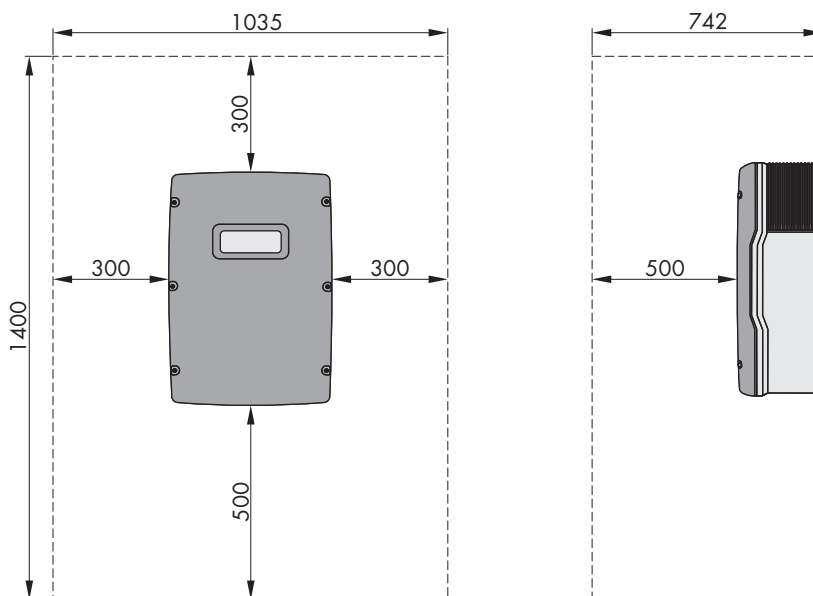

Figure 6: Recommended clearances if mounting several inverters (dimensions in mm)

5.2 Mounting the Sunny Island

⚠ QUALIFIED PERSON

i Mounting Sunny Island devices with multicluster communication

The multicluster data modules are installed in the master at the factory if multicluster communication has been ordered. The master can be identified by the labeling on the packaging.

- With multicluster systems, mount the Sunny Island devices with installed multicluster data modules at the mounting location planned for master devices.

Additionally required mounting material (not included in the scope of delivery):

- At least two screws that are suitable for the foundation
- At least two washers that are suitable for the screws
- At least two screw anchors that are suitable for the support surface and the screws
- If the inverter is to be secured against theft, two security screws that can only be unscrewed with a special tool.

Procedure:

⚠ CAUTION

Risk of injury when lifting the inverter, or if it is dropped

The Sunny Island inverter 4.4M weighs 44 kg, the Sunny Island inverter 6.0H / 8.0H weighs 63 kg. There is risk of injury if the inverter is lifted incorrectly or dropped while being transported or when attaching it to or removing it from the wall mounting bracket.

- Transport and lift the inverter carefully.

1. ⚠ CAUTION

Risk of injury due to damaged cables

There may be power cables or other supply lines (e.g. gas or water) routed in the wall.

- Ensure that no lines are laid in the wall which could be damaged when drilling holes.

2. Mark the position of the drill holes using the wall mounting bracket. Use at least one hole on the right-hand and left-hand side in the wall mounting bracket.
3. Drill the holes and insert the screw anchors.
4. Secure the wall mounting bracket horizontally on the wall using screws and washers.
5. If the Sunny Island is to be secured against theft, mark the drill holes for the anti-theft device. Use at least one hole on the right and one on the left.
6. Mount the SI4.4M-12 to the wall mounting bracket. For this, use the side recess grips. Keep the Sunny Island in a horizontal position when moving it.

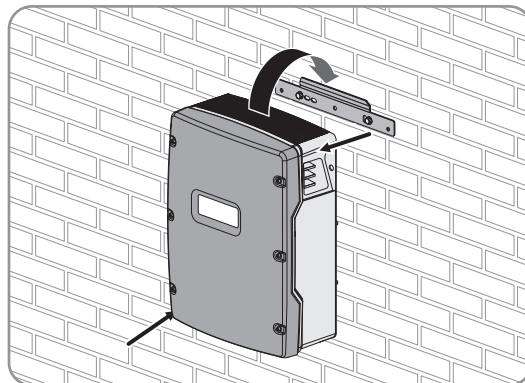

7. Mount the SI6.0H-12 and SI8.0H-12 to the wall mounting bracket. For this, use the side recess grips or a steel rod (diameter: maximum 30 mm). Keep the Sunny Island in a horizontal position when moving it.

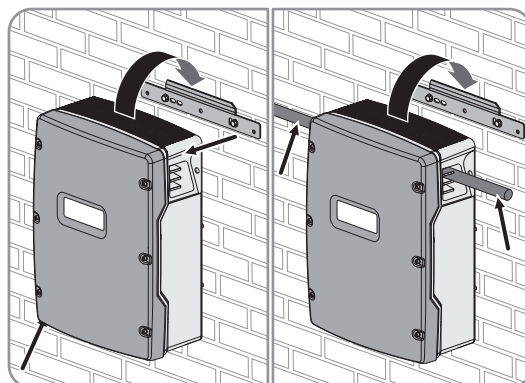

8. Use an Allen key (AF 5) to attach the Sunny Island to the wall mounting bracket on both sides with the M6x10 screws provided (torque: 4 Nm to 5.7 Nm). This will prevent the Sunny Island from being lifted off the bracket.

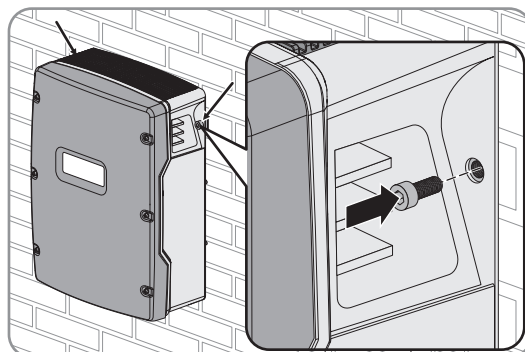

9. Close the recessed grips with the ventilation grids. Place the ventilation grid marked links/left on the left recessed grip and the ventilation grid marked rechts/right on the right recessed grip.

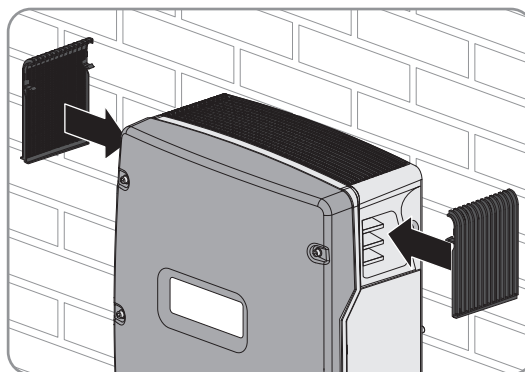

10. In order to protect the Sunny Island against theft, attach the bottom side to the wall with two security screws.

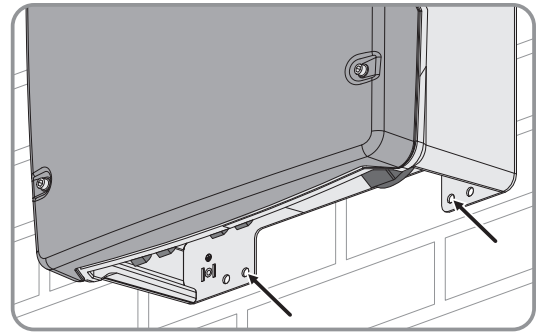

11. Ensure that the Sunny Island is firmly attached.

6 Electrical Connection

6.1 Content and Structure of the Section

Some of the following sub-sections relate to the physical connection of components or the use of physical connections on the Sunny Island. Other sub-sections describe actions that must always be performed.

An overview detailing which contents the sub-sections describe can be found in the following table.

| Section | Explanation |
|----------------------|---|
| Section 6.2, page 31 | Graphic overview of the connection area |
| Section 6.3, page 32 | The section must be read and observed if the optional micro SD card is to be inserted. |
| Section 6.4, page 32 | For systems with a grounded battery, this section must be read and observed. |
| Section 6.5, page 33 | Information on the connection and circuitry of individual devices with specification of connections on the Sunny Island You must read and observe the sub-sections for the components connected to the Sunny Island. |
| Section 6.6, page 59 | Correct connection of the cables to the respective connections on the Sunny Island You must read and observe the sub-sections for the connections on the Sunny Island used. |
| Section 6.7, page 68 | You must read and observe the section for the connections used. |
| Section 6.8, page 72 | You must always read and observe this section. |
| Section 6.9, page 73 | You must always read and observe this section. |

6.2 Overview of the Connection Area

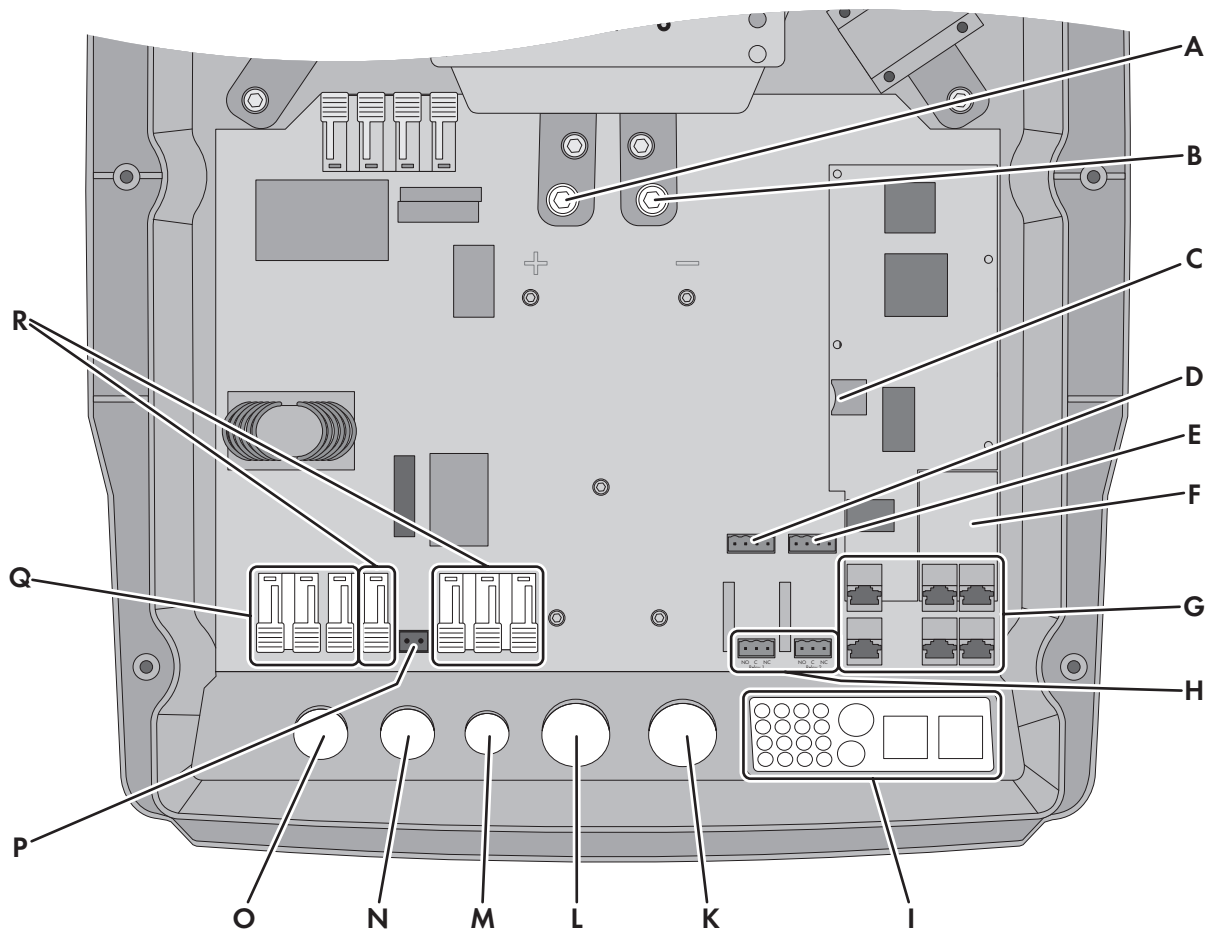

Figure 7: Connection area of the Sunny Island inverter

| Position | Designation | Position | Designation |
|----------|--|----------|----------------------------------|
| A | DC+ connection | K | Enclosure opening for DC- |
| B | DC- connection | L | Enclosure opening for DC+ |
| C | Slot for optional micro SD card | M | Enclosure opening ExtVtg |
| D | BatTmp and BatCur connections | N | Enclosure opening AC2 |
| E | BatVtgOut and DigIn connections | O | Enclosure opening AC1 |
| F | Slot for optional communication interface SI-SYSCAN.BGx* | P | ExtVtg connection |
| G | Connecting the communication unit | Q | AC1 connection |
| H | Relay1 and Relay2 connections | R | AC2 connection |
| I | Cable feed-through plate | | |

* If the inverter was ordered with the **Communication for multicluster system** order option, SI-SYSCAN.BGx is installed in each master.

6.3 Inserting the Micro SD Card

⚠ QUALIFIED PERSON

The optional micro SD card extends the data storage capacity of the inverter (see Section 17.13, page 186). The micro SD card can be ordered as an optional accessory from SMA Solar Technology AG or purchased via specialist retailers. Perform the following steps to insert the micro SD card.

NOTICE

Damage to the inverter due to electrostatic discharge

Touching electronic components can cause damage to or destroy the inverter through electrostatic discharge.

- Ground yourself before touching any component.

Requirements on the micro SD card:

- A micro SD card must be used. Other memory cards (e.g. MMC cards) may not be used.
- Data storage in the FAT16/32 file format must be possible.
- Minimum storage capacity: 1 GB
- Maximum storage capacity: 64 GB
- Quality: industry standard

Requirements:

- The micro SD card must be available.
- The inverter must be disconnected from all voltage sources (see Section 13, page 132).

Procedure:

1. On the Sunny Island, remove all screws of the lower enclosure lid using an Allen key (AF 5) and remove the enclosure lid. Retain the screws and conical spring washers for later use.
2. Insert the micro SD card into the slot up to the stop. Do not jam the micro SD card when doing so.
3. Ensure that the micro SD card is correctly plugged in.

6.4 Connecting the Grounding Conductor with a Grounded Battery

⚠ QUALIFIED PERSON

If you ground the battery, you can ground it at the positive terminal or at the negative terminal with a grounding conductor. SMA Solar Technology AG does not recommend grounding the battery. If the battery is grounded, the enclosure of the Sunny Island must also be grounded. This additional grounding is no substitute for the grounding at connections **AC1** und **AC2**.

Cable requirement:

- Material: Copper wire
- Minimum conductor cross-section: 10 mm² (or 2x 4 mm²)
- Maximum conductor cross-section: 16 mm²
- The cross-section of the grounding conductor must comply with the locally applicable standards and directives.
- The cross-section of the grounding conductor must be sized in accordance with the requirements of the external battery fuse.
- The cross-sections of the battery grounding conductor and Sunny Island inverter grounding conductor must be the same.

Procedure:

1. Calculate the cross-section of the grounding conductor. Observe all locally applicable standards and directives when doing so.
2. Ground the battery at the positive terminal or negative terminal using a conductor with the calculated cross-section.
3. Also ground the Sunny Island enclosure using a conductor with the calculated cross-section, as follows:
 - Strip off the insulation of the grounding conductor.
 - Place the clamping bracket over the conductor. Position the conductor on the left.

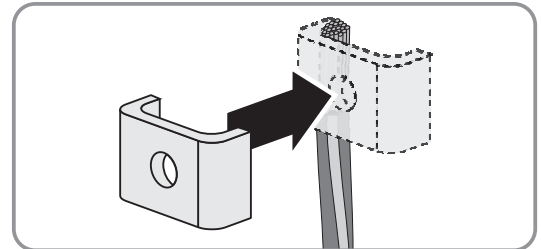

- Fasten the clamping bracket with the M6x16 hexagon socket screw and a conical spring washer (AF 5, torque: 4 Nm to 5.7 Nm). The teeth of the conical spring washer must face the clamping bracket.

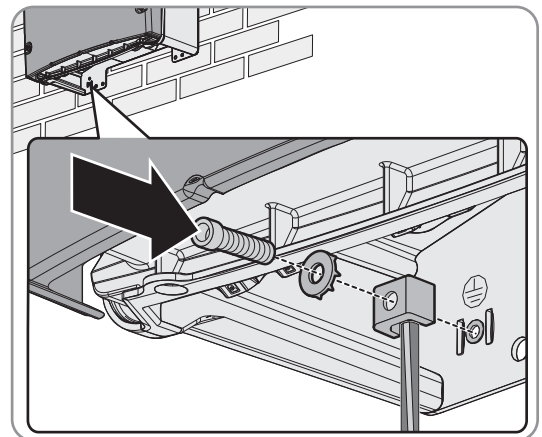

6.5 Connecting the Components

6.5.1 Connecting the Battery Fuse to the Sunny Island

⚠ QUALIFIED PERSON

i Selecting the battery fuse

The battery fuse safeguards the DC connection of the inverter against an overload caused by the battery. The battery fuse and the cabling with battery and inverter must be sized in accordance with the technical data of the DC connection (see Section 17.3, page 181).

Tip: Install a battery fuse of the type enwitec BAT FUSE B-01 or enwitec BAT FUSE B-03.

i Maximum cable length for the DC connection

Long cables and insufficient conductor cross-sections reduce the efficiency of the system and the overload capacity of the inverter.

- The length of all DC cables from the battery via the battery fuse to the Sunny Island must be smaller than 10 m.

The recommended minimum conductor cross-section depends on the battery voltage, the power and the length of the cable:

Cable requirements when using the inverter with an enwitec BAT FUSE B-01 or enwitec BAT FUSE B-03 battery fuse:

| Sunny Island | Cable length * | Conductor cross-section | Cable diameter | Terminal lug |
|--------------|----------------|-------------------------|----------------|-------------------------|
| SI8.0H | ≤ 5 m | 70 mm ² | 14 mm to 25 mm | M8, 20 mm to 25 mm wide |
| | > 5 m | 95 mm ² | 14 mm to 25 mm | M8, 20 mm to 25 mm wide |
| SI6.0H | ≤ 5 m | 50 mm ² | 14 mm to 25 mm | M8, 20 mm to 25 mm wide |
| | > 5 m | 70 mm ² | 14 mm to 25 mm | M8, 20 mm to 25 mm wide |
| SI4.4M | ≤ 5 m | 50 mm ² | 14 mm to 25 mm | M8, 20 mm to 25 mm wide |
| | > 5 m | 70 mm ² | 14 mm to 25 mm | M8, 20 mm to 25 mm wide |

* Cable length from the battery to the Sunny Island via the fuse switch-disconnector

⚠ WARNING

Danger to life due to incompatible lithium-ion battery

An incompatible lithium-ion battery can lead to a fire or an explosion. With incompatible lithium-ion batteries, it is not ensured that battery management is intrinsically safe and will protect the battery.

- Ensure that the lithium-ion batteries are approved for use with the Sunny Island (see technical information "List of Approved Batteries" at www.SMA-Solar.com).
- If no lithium-ion batteries approved for the inverter can be used, lead-acid batteries can be used.
- Verify that the battery complies with locally applicable standards and directives and is intrinsically safe.

Procedure:

1. Ensure that the load-break switch of the battery fuse is open and secured against reconnection.
2. On the Sunny Island, remove all screws of the lower enclosure lid using an Allen key (AF 5) and remove the enclosure lid. Retain the screws and conical spring washers for later use.
3. Connect the DC power cable of the battery fuse with the correct polarity (see Section 6.6.1 "Connecting the DC Power Cable", page 59).

6.5.2 Connecting the Utility Grid in the System for Increased Self-Consumption

⚠ QUALIFIED PERSON



Relevant for systems connected to the utility grid

Requirements:

- The system may not be a battery-backup system or an off-grid system.
- For connection of the Sunny Island inverter to the utility grid, there must be a circuit breaker and a type A residual-current device on the distribution board (see circuitry overview in the quick reference guide "SMA FLEXIBLE STORAGE SYSTEM")

Procedure:

1. On the Sunny Island, connect the power cable to the terminals **AC2 Gen/Grid** (see Section 6.6.2, page 62):

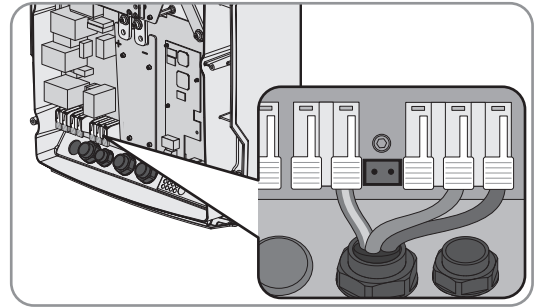

- Connect the line conductor to **AC2 Gen/Grid L**.
 - Connect the neutral conductor to **AC2 Gen/Grid NTT**.
2. Thread the grounding conductor through a ferrite included in the scope of delivery and connect to **AC2 Gen/Grid PE** (see Section 6.6.3, page 63).
 3. If the power cable conductor cross-section is less than 10 mm², thread an additional grounding conductor through the same ferrite and connect it to the **AC1 Loads/SunnyBoys PE** terminal (see Section 6.6.3, page 63).

6.5.3 Connecting an Automatic Transfer Switch in the Battery Backup System

6.5.3.1 Connecting the AC Power Cables of the Automatic Transfer Switch

⚠ QUALIFIED PERSON



Relevant for systems connected to the utility grid

The AC power cables conduct the energy between the battery-backup grid and the Sunny Island (see circuitry overview in the quick reference guide "SMA FLEXIBLE STORAGE SYSTEM with Battery-Backup Function").

Requirements:

- With each three-phase cluster, the connection of the line conductor must be prepared as follows: L1 to the master, L2 to slave 1 and L3 to slave 2. This results in a right-hand rotating magnetic field.
- The power of the AC sources in the battery backup grid must not exceed the maximum connected power of the PV inverters in the battery backup systems (see Section 17.2 "AC2 Connection for Utility Grid and Generator (External Energy Source)", page 181). The powers of the individual Sunny Island inverters are added to yield the total maximum power.

Procedure:

- Connect the power cable from **X3** on the automatic transfer switch to the terminals **AC2 Gen/Grid** on the Sunny Island. When doing so, connect the line conductor to **AC2 Gen/Grid L** and the neutral conductor to **AC2 Gen/Grid NTT** (see Section 6.6.2 "Connecting the AC Power Cable", page 62). Thread the grounding conductor through a ferrite included in the scope of delivery and connect to **AC2 Gen/Grid PE** (see Section 6.6.3 "Connecting the Grounding Conductor", page 63).

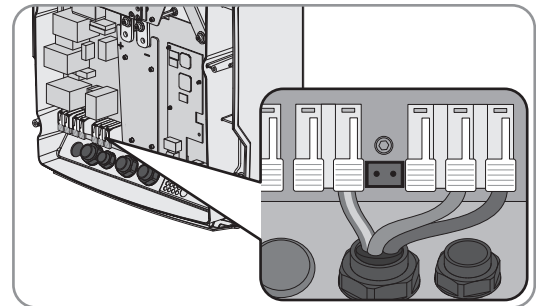

6.5.3.2 Connecting the Control Cables of the Automatic Transfer Switch

⚠ QUALIFIED PERSON



Relevant for systems connected to the utility grid

Control cables conduct the control signals of the multifunction relays to the contactors (see circuitry overview in the quick reference guide "SMA FLEXIBLE STORAGE SYSTEM with Battery-Backup Function").

i Cable route for control cables and measuring cables in the automatic transfer switch

An unfavorable cable route can lead to quality losses during the transmission of control signals and measured values. Observe the following rules for cable routes:

- Lay the control and measuring cables at the greatest possible distance from the power cables.
- Use shielded cables for the control and measuring cables.
- Always connect the digital input **DigIn** of the Sunny Island separately via a shielded cable.

Procedure:

1. On the master, connect the cable from **X5 L** and **X5 N** (for the control voltage) to terminal **AC1 Loads/SunnyBoys** (see Section 6.6.2 "Connecting the AC Power Cable", page 62).

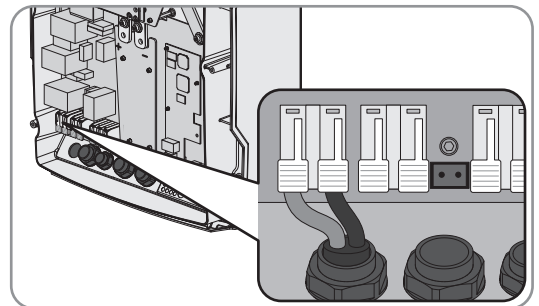

2. **⚠ WARNING**

Danger to life from electric shock due to incorrect insulation

- Connect the control cable from **X4 1** and **X4 2** to the connections **Relay1 C** and **Relay1 NC** (see Section 6.6.5 "Connecting Relay 1 and Relay 2", page 65).

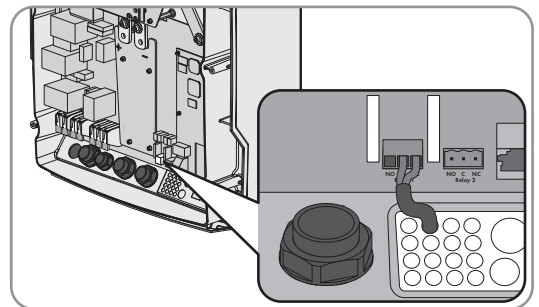

3. **⚠ WARNING**

Danger to life from electric shock due to incorrect insulation

- Connect the control cable from **X5 1** and **X5 2** to the connections **Relay2 C** and **Relay1 NO** (see Section 6.6.5 "Connecting Relay 1 and Relay 2", page 65).

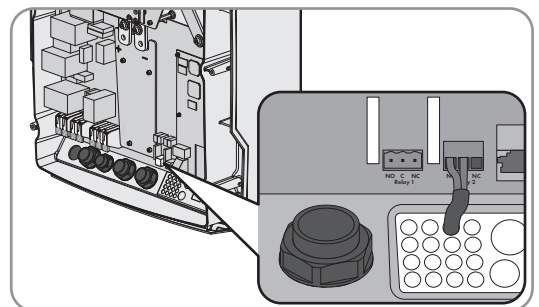

6.5.3.3 Connecting the Measuring Cables of the Automatic Transfer Switch

⚠ QUALIFIED PERSON



Relevant for systems connected to the utility grid

The Sunny Island measures the voltages of the respective line conductors via one measuring cable. In addition, the master measures whether the tie switch has activated or deactivated (see circuitry overview in the quick reference guide "SMA FLEXIBLE STORAGE SYSTEM with Battery-Backup Function").

i Cable route for control cables and measuring cables in the automatic transfer switch

An unfavorable cable route can lead to quality losses during the transmission of control signals and measured values. Observe the following rules for cable routes:

- Lay the control and measuring cables at the greatest possible distance from the power cables.
- Use shielded cables for the control and measuring cables.
- Always connect the digital input **DigIn** of the Sunny Island separately via a shielded cable.

Procedure:

1. On the Sunny Island, connect the measuring cable **X4 Ln** (Ln = L1 to L3) and **X4 N** for voltage monitoring to the **ExtVtg** terminal (see Section 6.6.7 "Connecting ExtVtg", page 67).

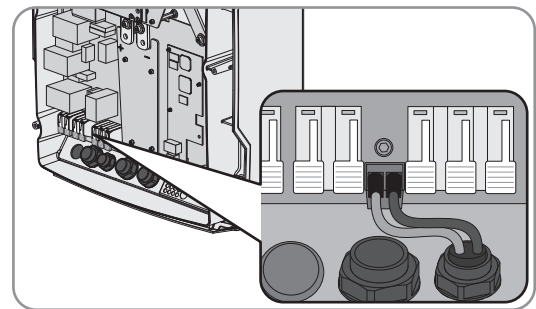

2. At the master, connect the tie switch monitoring (see Section 6.6.6 "Connecting BatVtgOut, DigIn, BatTMP and BatCur", page 66).
 - Connect the master **BatVtgOut-** with the **DigIn-**.
 - Thread both insulated conductors through a ferrite included in the scope of delivery.
 - Connect the insulated conductor from **X5 3** to **DigIn+**.
 - Connect the insulated conductor from **X5 4** to **BatVtgOut+**.

6.5.4 Connecting the Stand-Alone Grid or Multicenter-Box 6 / 36

⚠ QUALIFIED PERSON



Relevant for off-grid systems

In off-grid systems you connect AC loads and the grid-parallel AC sources (e.g. PV inverters) using an AC sub-distribution board to the **AC1** terminal of the Sunny Island. In the case of a multicenter system, the Multicenter-Box 6 or Multicenter-Box 36 is the AC distribution board that is connected to connection **AC1** (for the connection of device type MC-BOX-12.3-20 Multicenter-Box 12 (see Section 6.5.5, page 40).

Requirements for connecting Sunny Island inverters in single-phase parallel single-cluster systems:

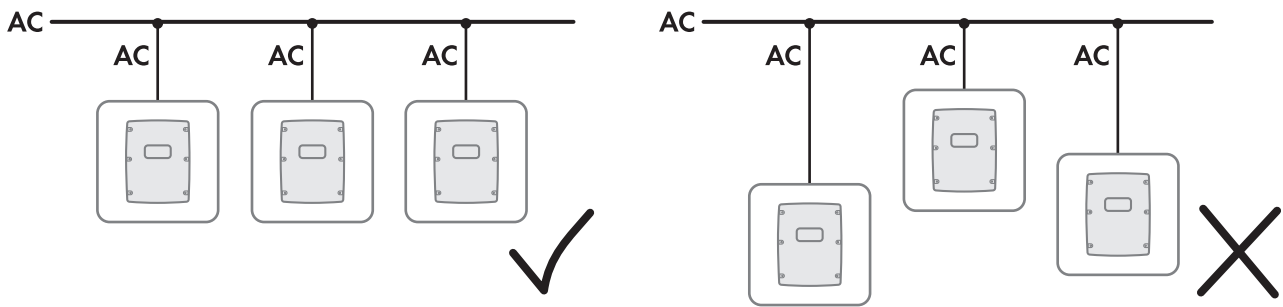

- For a single-phase parallel single-cluster system, the cable length and conductor cross-section from each Sunny Island to the AC distribution board must be identical. This will allow for stable and symmetric operation.

⚠ WARNING

Danger to life due to fire

In case of a short circuit, the short-circuit current driven by the generator flows over the unprotected cable between the Sunny Island and the AC distribution board. Short-circuit currents can cause fires.

- If the fuse on the generator has a higher operating current than the fuse in the AC distribution board, size the cable between the generator and AC distribution board in accordance with the operating current of the fuse on the generator.

1. On the Sunny Island, connect the cable to the **AC1 Loads/SunnyBoys** terminal (see Section 6.6.2 "Connecting the AC Power Cable", page 62).

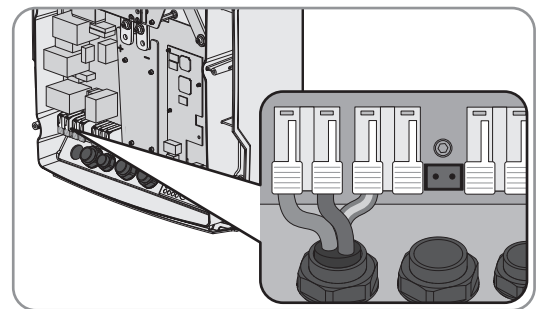

- Connect the line conductor to **AC1 Loads/SunnyBoys L**.
 - Connect the neutral conductor to **AC1 Loads/SunnyBoys N**.
2. In addition, thread the grounding conductor through a ferrite included in the scope of delivery and connect to **AC1 Loads/SunnyBoys PE** (see Section 6.6.3 "Connecting the Grounding Conductor", page 63).
 3. If the power cable conductor cross-section is less than 10 mm², thread an additional grounding conductor through the same ferrite and connect it to the **AC1 Loads/SunnyBoys PE** terminal. (see Section 6.6.3 "Connecting the Grounding Conductor", page 63).

6.5.5 Connection of Multicluster-Box 12 (MC-Box-12.3-20)

6.5.5.1 Connecting the AC Power Cable of the Multicluster-Box 12

⚠ QUALIFIED PERSON

⚠ WARNING

Danger to life due to fire

In case of a short circuit, the short-circuit current driven by the generator flows over the unprotected cable between the Sunny Island and the AC distribution board. Short-circuit currents can cause fires.

- If the fuse on the generator has a higher operating current than the fuse in the AC distribution board, size the cable between the generator and AC distribution board in accordance with the operating current of the fuse on the generator.

Requirement:

- The inverters to be connected must be Sunny Island 6.0H / 8.0H inverters.

Procedure:

1. Connect the power cable to the **AC2 Gen/Grid** terminal on all Sunny Island (see Section 6.6.2 "Connecting the AC Power Cable", page 62):

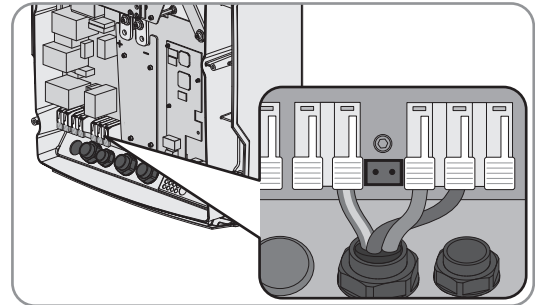

- Connect the line conductor to **AC2 Gen/Grid L**.
 - Connect the neutral conductor to **AC2 Gen/Grid N**.
2. Thread the grounding conductor through a ferrite included in the scope of delivery and connect to **AC2 Gen/Grid PE** (see Section 6.6.3, page 63).

6.5.5.2 Connecting the Control Cable of the Multicluster-Box 12

⚠ QUALIFIED PERSON

Requirement:

- The inverters to be connected must be Sunny Island 6.0H / 8.0H inverters.

Procedure:

1. On the master of the main cluster, connect the **X106 1** line conductor and **X106 2** neutral conductor (for the control voltage) to terminal **AC1 Loads/SunnyBoys** (see Section 6.6.2 "Connecting the AC Power Cable", page 62).

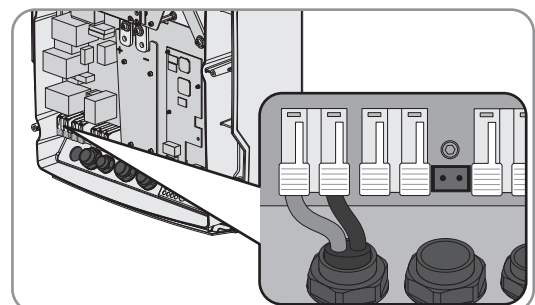

2. **⚠ WARNING****Danger to life from electric shock due to incorrect insulation**

- On the master of the main cluster, connect the control cable of **X113 1** and **X113 2** to the **Relay2 C** and **Relay2 NO** (see Section 6.6.5 "Connecting Relay 1 and Relay 2", page 65).

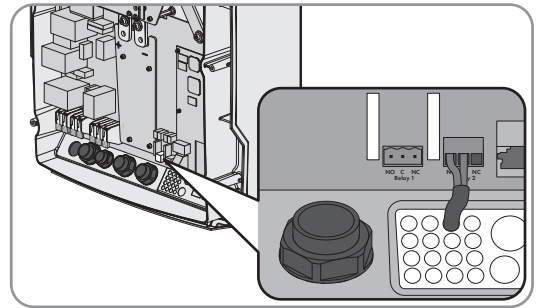
3. **⚠ WARNING****Danger to life from electric shock due to incorrect insulation**

- On the master of the main cluster, connect the control cable of **X112 1** and **X112 2** to the **Relay1 C** and **Relay1 NC** terminals when an NA-Box or Grid-Connect-Box is installed in addition to the Multicluster-Box 12 (see Section 6.6.5 "Connecting Relay 1 and Relay 2", page 65).

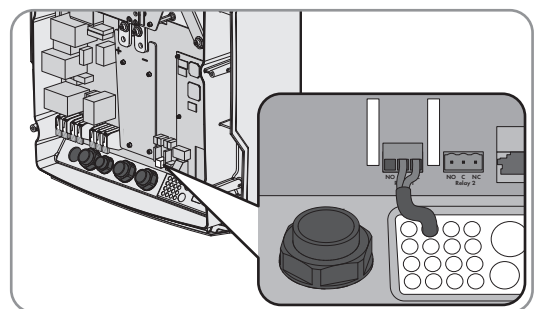
4. **⚠ WARNING****Danger to life from electric shock due to incorrect insulation**

- On slave 1 of the main cluster, connect the control cable of **X112 5** and **X112 6** to the **Relay2 C** and **Relay2 NC** terminals when an NA-Box or Grid-Connect-Box is installed in addition to the Multicluster-Box 12 (see Section 6.6.5 "Connecting Relay 1 and Relay 2", page 65).

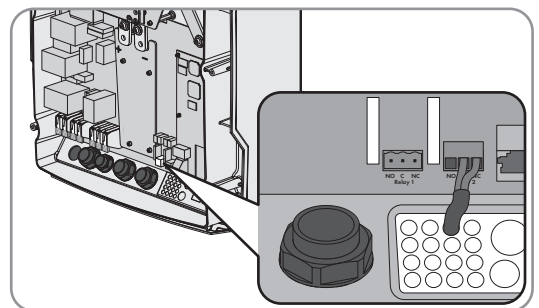
**6.5.5.3 Connecting the Measuring Cable of the Multicluster-Box 12****⚠ QUALIFIED PERSON****Requirements:**

- The inverters to be connected must be Sunny Island 6.0H / 8.0H inverters.
- The utility grid must be connected to the multicluster system (see Multicluster-Box 12 operating manual).

Procedure:

1. On every Sunny Island of the main cluster, connect the measuring cable for voltage monitoring of the Multicluster-Box 12 to the **ExtVtg** terminal (see Section 6.6.7 "Connecting ExtVtg", page 67):

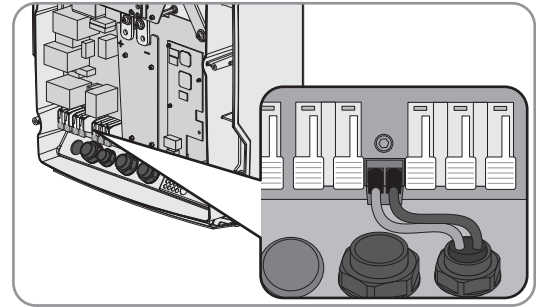

- On the master, connect the **X112 3** and **X112 4** conductors to **ExtVtg**.
 - On slave 1, connect the **X112 7** and **X112 8** insulated conductors to **ExtVtg**.
 - On slave 2, connect the **X112 9** and **X112 10** insulated conductors to **ExtVtg**.
2. At the master, connect the AC contactor monitoring (see Section 6.6.6 "Connecting BatVtgOut, DigIn, BatTMP and BatCur", page 66):

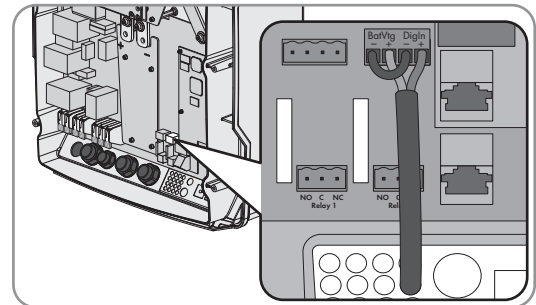

- Connect the master **BatVtgOut-** with the **DigIn-**.
- Thread both insulated conductors through a ferrite included in the scope of delivery.
- Connect the insulated conductor from **X113 3** to **BatVtgOut+**.
- Connect the insulated conductor from **X113 4** to **DigIn+**.

6.5.6 Connecting the Generator in an Off-Grid System

⚠ QUALIFIED PERSON

🔌 Relevant for off-grid systems

For a single system and single-cluster system, connect the generator to the **AC2** terminal of the Sunny Island. For a multicluster system, connect the generator directly to the Multicluster-Box (see the Multicluster-Box documentation).

⚠ WARNING

Danger to life from electric shock due to incorrect connection of the neutral conductor

Connecting the neutral conductor incorrectly can cause failure of the protective functions in the system. This can result in death or serious injury.

- Connect the neutral conductor to terminal **AC2 Gen/Grid N**.

Requirements:

- A separate cable must be laid for each Sunny Island from the AC distribution board or directly from the generator.
- For a single-phase parallel cluster, the cable length and the conductor cross-section must be identical from each Sunny Island to the AC distribution board or directly to the generator.
- With each three-phase cluster, the connection of the line conductor must be prepared as follows: L1 to the master, L2 to slave 1 and L3 to slave 2. This results in a right-hand rotating magnetic field.

Procedure:

1. Connect the power cable to the **AC2 Gen/Grid** terminal on the Sunny Island. To do this, connect the neutral conductor to terminal **N** (see Section 6.6.2 "Connecting the AC Power Cable", page 62).

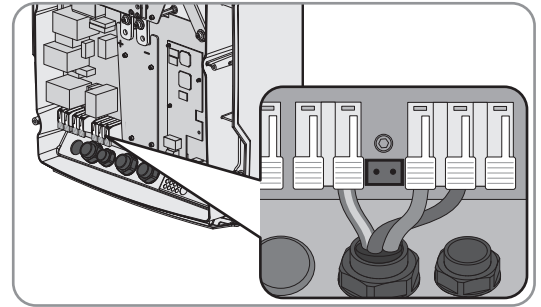

- Connect the line conductor to **AC2 Gen/Grid L**.
 - Connect the neutral conductor to **AC2 Gen/Grid N**.
2. Thread the grounding conductor through a ferrite included in the scope of delivery and connect to **AC2 Gen/Grid PE** (see Section 6.6.3 "Connecting the Grounding Conductor", page 63).

6.5.7 Communication Connection

6.5.7.1 Connecting the Communication Product via Speedwire

⚠ QUALIFIED PERSON

Cable requirements:

- Cable length between two nodes:
Maximum 50 m with patch cable
Maximum 100 m with installation cable
- Cross-section: at least 2 x 2 x 0.22 mm² or at least 2 x 2 x 24 AWG
- Cable type: 100BaseTx, CAT5 with S-UTP, F-UTP shielding or higher
- Type of plug: RJ45

Procedure:

1. Insert the data cable in the pin connector **ComETH** on the Sunny Island (see Section 6.6.4 "Connecting the Data Cable", page 64).

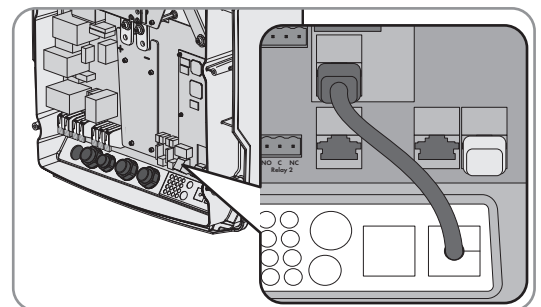

2. Connect the other end of the data cable to the router or network switch.

6.5.7.2 Connecting the Data Cable of the Lithium-Ion Batteries

⚠ QUALIFIED PERSON

Requirements:

- The total length of the communication bus must not exceed 30 m. Keep in mind that the communication bus possibly connects several nodes.

Cable requirements:

- Classification: CAT5e
- Type of plug: RJ45

Procedure:

1. Plug the data cable into a free pin connector **ComSync** on the Sunny Island (see Section 6.6.4 "Connecting the Data Cable", page 64).

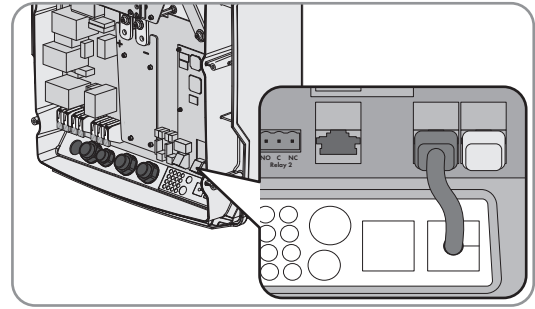

2. Connect the other end of the data cable to the battery management of the lithium-ion battery (see battery manufacturer documentation).
3. Ensure that the communication bus is closed at each end, e.g. with a terminator.

6.5.7.3 Connecting the Data Cable for the Internal Communication of the Cluster**⚠ QUALIFIED PERSON**

In a cluster, the Sunny Island inverters communicate via a black data cable.

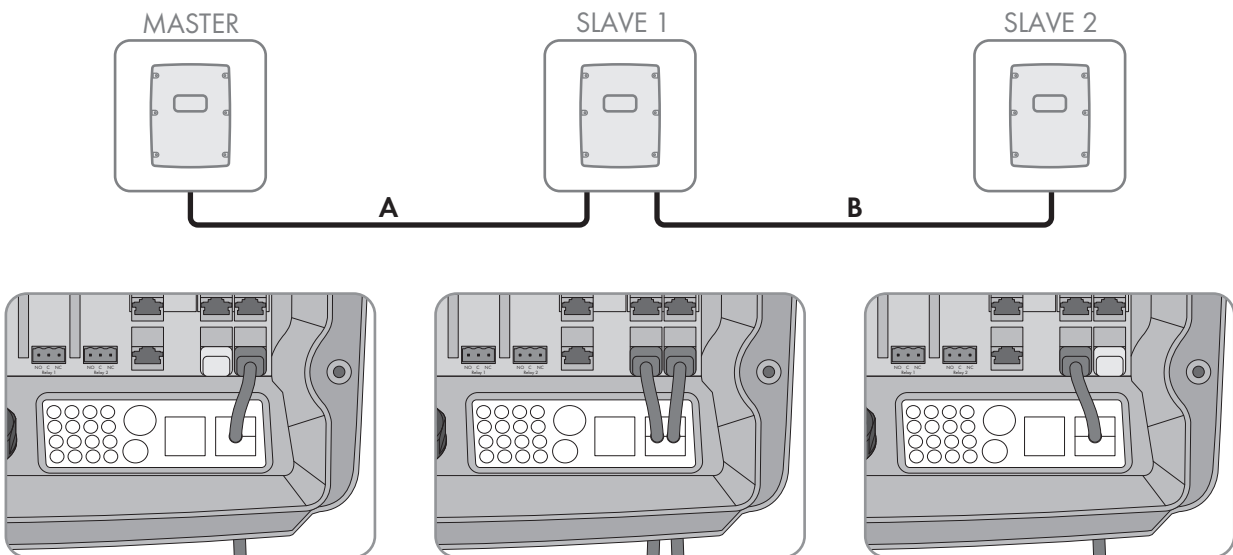
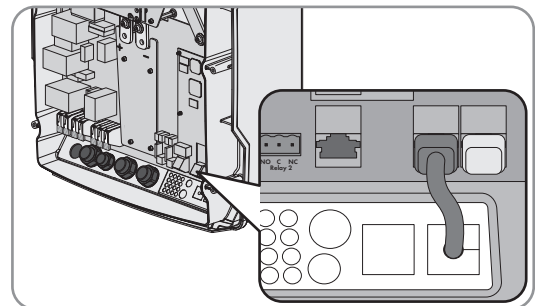

Figure 8: Internal communication cabling (example)

Requirements:

- The total length of the communication bus (A+B) must be less than 30 m. Keep in mind that the communication bus possibly connects several nodes.
1. Plug the data cable into a free pin connector **ComSync** on the Sunny Island (see Section 6.6.4 "Connecting the Data Cable", page 64).



2. Ensure that the communication bus is closed at each end, e.g. with a terminator.

6.5.7.4 Connecting the Data Cable of the Multicluster-Box

⚠ QUALIFIED PERSON

For a multicluster system, the Multicluster-Box communicates with the master of the main cluster via a black data cable (see Multicluster-Box documentation). The black data cable is part of the scope of delivery of the Multicluster-Box.

Requirements:

- The total length of the communication bus must not exceed 30 m. Keep in mind that the communication bus possibly connects several nodes.

Cable requirements:

- Classification: CAT5e
- Type of plug: RJ45

Procedure:

1. Plug the data cable into a free pin connector **ComSync** on the Sunny Island (see Section 6.6.4 "Connecting the Data Cable", page 64).

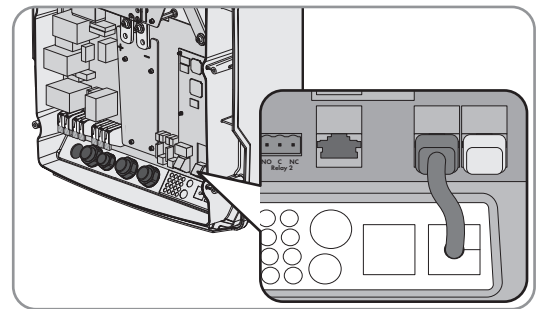

2. Connect the other end of the data cable to the Multicluster-Box (see Multicluster-Box documentation).
3. Ensure that the communication bus is closed at each end, e.g. with a terminator.

6.5.7.5 Connecting Control and Measuring Cables of the Multicluster-Box

⚠ QUALIFIED PERSON

For a multicluster system, the Multicluster-Box communicates control and measuring data with the three Sunny Island inverters of the main cluster via three red data cables (see Multicluster-Box documentation). The red data cables are part of the scope of delivery of the Multicluster-Box.

Cable requirements:

- Cable length for BatVtgOut, DigIn and BatTemp: less than 30 m

Procedure:

- Plug the red data cables into the pin connector **BackupVtgCur** on the Sunny Island units of the main cluster (see Section 6.6.4 "Connecting the Data Cable", page 64). Connect the master with the connection **Mstr./L1**, slave 1 with the connection **Slv1./L2** and slave 2 with the connection **Slv2./L3** on the Multicluster-Box.

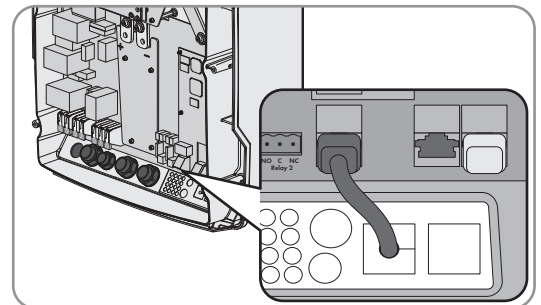

6.5.7.6 Connecting the Data Cables for Multicluster Communication

⚠ QUALIFIED PERSON

In a multicluster system, the masters of the various clusters communicate with each other (see Multicluster-Box documentation). An SI-SYSCAN.BGx communication interface must be installed in each master for Multicluster communication. This communication is not necessary for a multicluster system with one cluster. If the Sunny Island was ordered with the **Communication for multicluster system** order option, SI-SYSCAN.BGx is installed in each master.

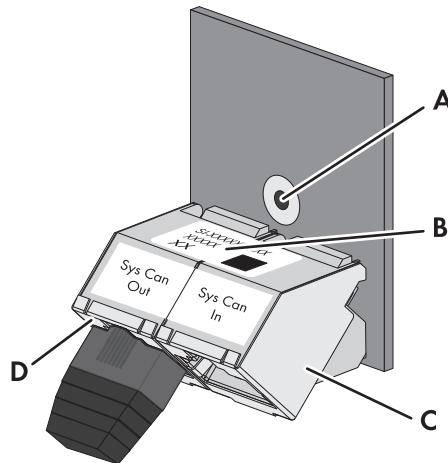

Figure 9: Design of the SI-SYSCAN.BGx

| Position | Designation |
|----------|-------------------------------|
| A | Mounting hole |
| B | Type label |
| C | SysCanIn pin connector |
| D | SysCanOut jack |

Cable requirements:

- Classification: CAT5e
- Maximum cable length: 30 m

Procedure:

1. If no SI-SYSCAN.BGx communication interface is installed, install SI-SYSCAN.BGx in each master (see SI-SYSCAN-NR documentation).
2. Remove the terminator from the **SysCanOut** pin connector on the master of the main cluster and plug it into the SysCanIn pin connector.
3. Plug the yellow data cable into the **SysCanOut** pin connector on the main cluster master (see Section 6.6.4 "Connecting the Data Cable", page 64).
4. Plug the other end of the yellow data cable into the SysCanIn pin connector on the master of the extension cluster 1.
5. Connect the other extension clusters with each other as described in steps 3 and 4. Remove the terminators for this.
6. Leave the terminator plugged into the unused **SysCanOut** pin connector. This terminates the communication bus.

6.5.8 Connecting the Battery Temperature Sensor

⚠ QUALIFIED PERSON

With lead-acid batteries, the battery management of the Sunny Island inverter must record the temperature of the connected battery.

i Battery temperature sensor in a cluster

Only the master measures the battery temperature in a cluster.

- Connect the battery temperature sensor only to the master.

NOTICE

Damage to the battery due to excessive charging voltage

Due to incorrect temperature measurements, the Sunny Island charges the battery with an incorrect charging voltage.

- Connect only the battery temperature sensor supplied.
- Attach the battery temperature sensor in the centre of the battery-storage system, in the upper third of the battery cell.

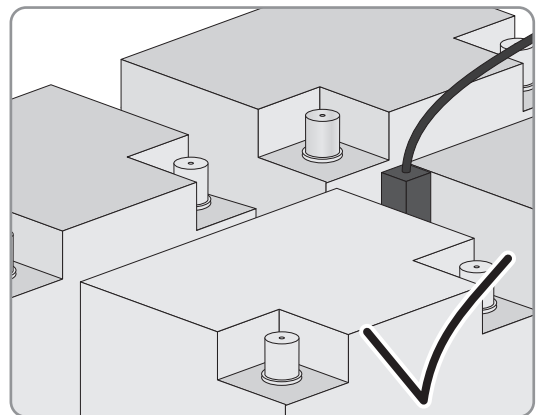

- The battery temperature sensor measures the warmest point of the battery-storage system.

Requirement:

- Cable length for BatVtgOut, DigIn and BatTemp: less than 30 m

Procedure:

- Thread both insulated conductors of the sensor through a ferrite included in the scope of delivery and connect to the terminals **BatTmp** on the Sunny Island (see Section 6.6.6 "Connecting BatVtgOut, DigIn, BatTMP and BatCur", page 66). In this case, the polarity is arbitrary.

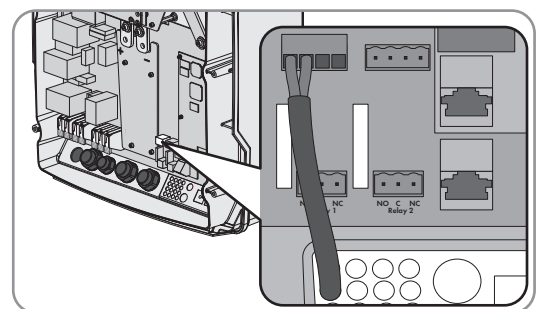

6.5.9 Connecting the Battery Current Sensor in the Off-Grid System

⚠ QUALIFIED PERSON

When using lead-acid batteries, a battery current sensor can be installed for precise measurement of the battery current.

⚠ Relevant for off-grid systems

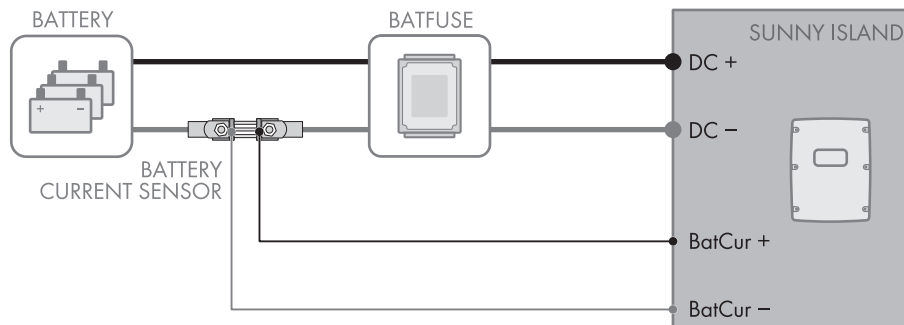

Figure 10: Connection of the battery current sensor to the Sunny Island.

Cable requirements:

- Copper wire
- Maximum cable length: 3 m
- Conductor cross-section: 0.2 mm² to 2.5 mm²
- A measuring cable with intrinsically safe current circuits must be used. For this purpose, “intrinsically safe” means that the cable is double-insulated and that, in the event of a short circuit, the conductor melts but the insulation remains intact. In addition, the cable is not combustible.
- Insulated conductors in the measuring cable must be twisted.

Procedure:

1. Install the battery current sensor in the **DC** power cable between the battery and the battery fuse.
2. Connect the **BatCur+** insulated measuring conductor to the side for connecting the battery fuse on the battery current sensor.
3. Connect the **BatCur-** insulated measuring conductor to the side for connecting the battery on the battery current sensor.

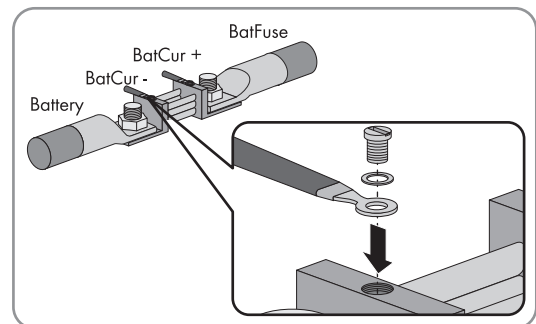
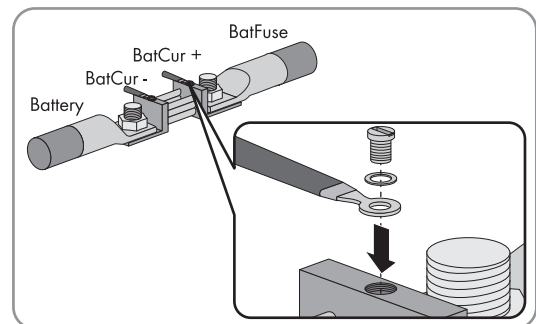

4. Thread both insulated conductors through a ferrite included in the scope of delivery and connect to the terminals **BatCur+** und **BatCur-** on the Sunny Island (see Section 6.6.6 "Connecting BatVtgOut, DigIn, BatTMP and BatCur", page 66).

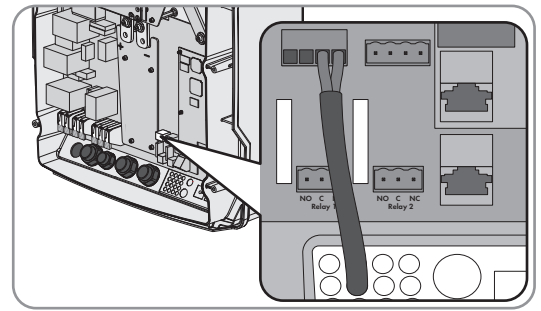

6.5.10 Connecting the Control Cable for Autostart Generators

⚠ QUALIFIED PERSON

🔌 Relevant for off-grid systems

Autostart generators are started and stopped with a contact.

i Signal generator or generator control in a cluster

Slaves control the generator less reliably than masters do.

- Connect the generator control preferably to the master.
- In a multicluster system, always connect the signal generator to the master of the main cluster.



Figure 11: Connecting the Generator Control to Sunny Island

Requirements:

- The technical requirements of the multifunction relay must be met (see Section 17 "Technical Data", page 180).

Cable requirements:

- Copper wire
- Conductor cross-section: 0.2 mm² to 2.5 mm²

Procedure:

1. ⚠ WARNING

Danger to life from electric shock due to incorrect insulation

- The default setting of the Sunny Island uses the multifunction relay **Relay1** for generator requests. Therefore, connect the control cable to the multifunction relay **Relay1** on the Sunny Island (see Section 6.6.5 "Connecting Relay 1 and Relay 2", page 65). Use the **C** and **NO** connections.

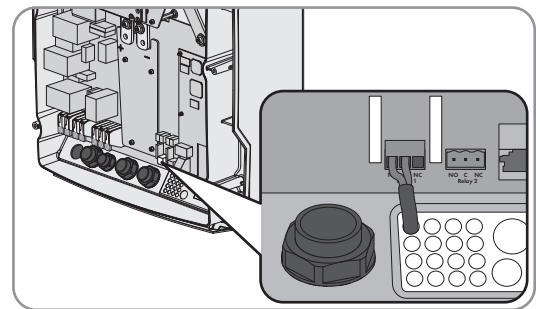

- If the multifunction relay **Relay1** for generator requests is not available, connect the control cable to the multifunction relay **Relay2** on the Sunny Island (see Section 6.6.5 "Connecting Relay 1 and Relay 2", page 65). Use the **C** and **NO** connections.
- If, with more than one Sunny Island, the multifunction relay **Relay1** and **Relay2** for generator requests are not available on the Master, connect the control cable to a free multifunction relay on slave 1 or slave 2. Use the **C** and **NO** connections.

2. Enter the configuration **Automatic generator request** in the table of settings (see Section 7.10.2 "Setting the Functions of the Multifunction Relays", page 108).

6.5.11 Connecting a Signaler for Generators Without an Autostart Function

⚠ QUALIFIED PERSON

🔧 Relevant for off-grid systems

Generators without an autostart function do not have electric starting devices. If you install a generator without an autostart function, you can connect a signal generator (e.g., signal lamp) to the multifunction relay of the Sunny Island inverter. As a result, the Sunny Island can signal when the generator is to be manually started and stopped.

i Signal generator or generator control in a cluster

Slaves control the generator less reliably than masters do.

- Connect the generator control preferably to the master.
- In a multicluster system, always connect the signal generator to the master of the main cluster.

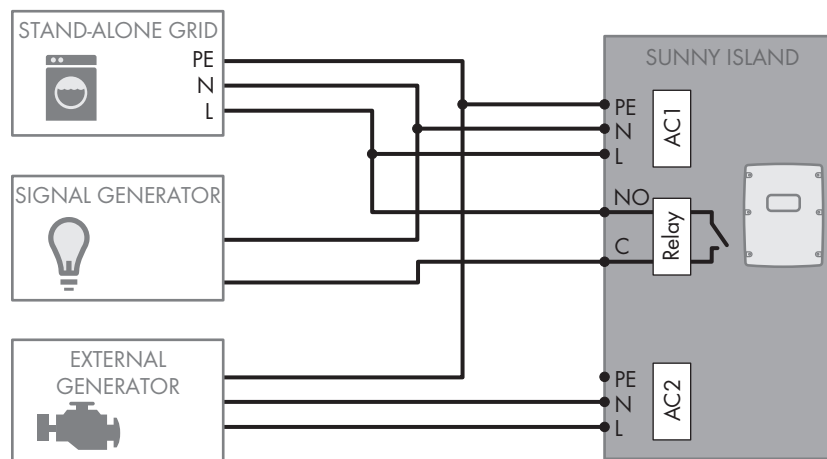

Figure 12: Connecting a Signal Generator to Signal a Generator Request (Example)

Requirements:

- The technical requirements of the multifunction relay must be met (see Section 17 "Technical Data", page 180).

Cable requirements:

- Copper wire
- Conductor cross-section: 0.2 mm² to 2.5 mm²

Procedure:1. **⚠ WARNING****Danger to life from electric shock due to incorrect insulation**

- The default setting of the Sunny Island uses the multifunction relay **Relay1** for generator requests. Therefore, connect the control cable to the multifunction relay **Relay1** on the Sunny Island (see Section 6.6.5 "Connecting Relay 1 and Relay 2", page 65). Use the **C** and **NO** connections.

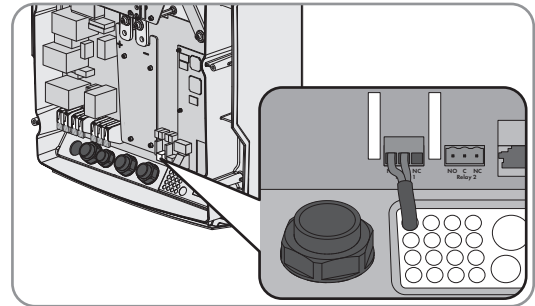

- If the multifunction relay **Relay1** for generator requests is not available, connect the control cable to the multifunction relay **Relay2** on the Sunny Island (see Section 6.6.5 "Connecting Relay 1 and Relay 2", page 65). Use the **C** and **NO** connections.
 - If, with more than one Sunny Island, the multifunction relay **Relay1** and **Relay2** for generator requests are not available on the Master, connect the control cable to a free multifunction relay on slave 1 or slave 2. Use the **C** and **NO** connections.
2. Enter the configuration **Automatic generator request** in the table of settings (see Section 7.10.2 "Setting the Functions of the Multifunction Relays", page 108).

6.5.12 Connecting Load-Shedding Contactors**⚠ QUALIFIED PERSON****🔌 Relevant for off-grid systems**

Load shedding prevents battery deep discharge and controls the supply of energy to the loads. Load shedding provides the option of disconnecting specific loads from the system.

Load shedding is necessary for an off-grid system that is exclusively supplied with PV energy or wind energy.

The Sunny Island controls up to two load-shedding contactors depending on the state of charge of the battery. You can install two types of load shedding:

- **One-level load shedding**
If the battery state of charge limit has been reached, one load-shedding contactor disconnects all loads at the same time. Depending on the configuration, the load-shedding contactor closes when the battery has been sufficiently charged or when the stand-alone grid has been switched to an external energy source.
- **Two-level load shedding**
In two-level load shedding, there are two thresholds for the state of charge of the battery in order to control two load-shedding contactors. When the first threshold for the state of charge of the battery is reached, the first load-shedding contactor disconnects a group of loads. When the second threshold for the state of charge of the battery is reached, the second load-shedding contactor disconnects the remaining loads.

i Load shedding in a multicluster system

One-level load shedding is integrated into the Multicluster-Box. The load-shedding contactor is controlled directly by the master of the main cluster via communication with the Multicluster-Box. If you install an additional load-shedding contactor in a multicluster system, it is controlled with a multifunction relay in the master of extension cluster 1. Additional load-shedding contactors cannot be controlled by the main cluster.

i Load-shedding contactors in a cluster

If you connect load-shedding contactors to the master, limited operation is possible in the event of a disturbance. Slaves can control the load-shedding contactors less reliably in the event of a fault. In the event of a disturbance, the slave may wait for confirmation from the master.

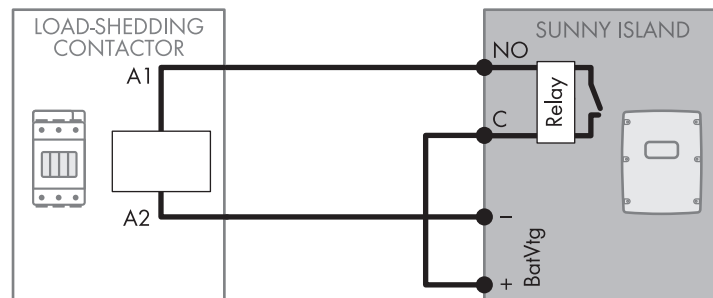

Figure 13: Connection of control cable for one-level load shedding (example)

Requirements:

- The technical requirements of the multifunction relay must be met (see Section 17 "Technical Data", page 180).

Cable requirements:

- Copper wire
- Conductor cross-section: 0.2 mm² to 2.5 mm²

Procedure:

1. Ensure that the load-shedding contactor only disconnects loads from the system. This ensures that the battery can be recharged from AC sources in the system.
2. When connecting the load shedding, preferably use the multifunction relay **Relay2**. Since the default setting of Sunny Island uses the multifunction relay **Relay2** for load shedding. Perform the following steps:
 - Connect the insulated conductor for coil connection **A1** of the load-shedding contactor on the Sunny Island to terminal **Relay2 NO** (see Section 6.6.5 "Connecting Relay 1 and Relay 2", page 65).
 - Connect the insulated conductor for coil connection **A2** to terminal **BatVtgOut-** (see Section 6.6.6 "Connecting BatVtgOut, DigIn, BatTMP and BatCur", page 66).
 - Connect terminal **BatVtgOut +** to terminal **Relay2 C**. Use the same conductor cross-section as that of the cable for the load-shedding contactor.
3. If the multifunction relay **Relay2** for load shedding is not available, use the multifunction relay **Relay1** when connecting the load shedding. Perform the following steps:
 - Connect the insulated conductor for coil connection **A1** of the load-shedding contactor on the Sunny Island to terminal **Relay1 NO** (see Section 6.6.5 "Connecting Relay 1 and Relay 2", page 65).
 - Connect the insulated conductor for coil connection **A2** to terminal **BatVtgOut-** (see Section 6.6.6 "Connecting BatVtgOut, DigIn, BatTMP and BatCur", page 66).
 - Connect terminal **BatVtgOut +** to terminal **Relay1 C**. Use the same conductor cross-section as that of the cable for the load-shedding contactor.
4. Enter the selected configuration into the table of the settings (see Section 7.10.2 "Setting the Functions of the Multifunction Relays", page 108):

| Value | Explanation |
|-------------------------|--|
| One-level load shedding | Setting for one-level load shedding. When the Sunny Island switches to an external energy source, load shedding is stopped and the loads are supplied by the external energy source. The battery is only charged with the excess energy. |

| Value | Explanation |
|---|--|
| One-level load shedding or the first level of two-level load shedding | Setting for one-level load shedding or the first level of two-level load shedding. Load shedding is only stopped when the battery has been sufficiently charged. |
| | Setting for the second level of two-level load shedding. Load shedding is only stopped when the battery has been sufficiently charged. |
| Load shedding in the multicluster system | Setting for additional one-level load shedding in a multicluster system. Load shedding is only stopped when the batteries of the extension cluster have been sufficiently charged. |

- Repeat steps 1 to 5 for two-level load shedding. Connect the second load-shedding contactor to an unused multifunction relay.

6.5.13 Connecting the Time Control for External Processes

⚠ QUALIFIED PERSON

The Sunny Island has two timers for time-dependent control of external processes. For each timer, you can set the starting day and time that the multifunction relay is to be switched once, daily or weekly.

Requirements:

- The technical requirements of the multifunction relay must be met (see Section 17 "Technical Data", page 180).

Cable requirements:

- Copper wire
- Conductor cross-section: 0.2 mm² to 2.5 mm²

1. ⚠ WARNING

Danger to life from electric shock due to incorrect insulation

- Connect the control cable on the Sunny Island to either multifunction relay **Relay1** or **Relay2** (see Section 6.6.5 "Connecting Relay 1 and Relay 2", page 65). Use the **C** and **NO** connections.

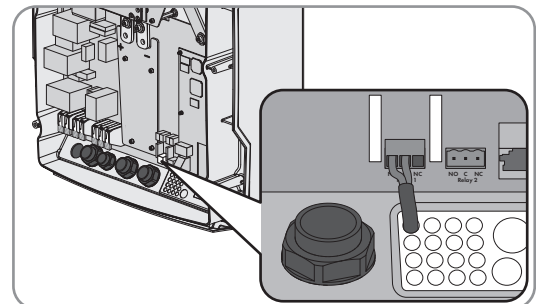

- During configuration, enter the value **TM1** for timer 1 or the value **TM2** for timer 2 in the table of settings (see Section 7.10.2 "Setting the Functions of the Multifunction Relays", page 108).

6.5.14 Connecting Message Devices for Operating States and Warning Messages

⚠ QUALIFIED PERSON

You can connect message devices to the multifunction relays to allow operating states and warning messages from the Sunny Island inverter to be output. One of the following operating states and warning messages can be displayed for each multifunction relay:

- The PV array is running and is connected.
- Voltage and frequency of the utility grid are within the range for connection.
- A Sunny Island displays an error message of level 2 or higher. Only the error messages within a cluster are evaluated here.

i Different control logic for error messages of level 2 or higher

A different control logic of level 2 ensures that the error message will also be displayed in the case of automatic shutdown.

- When an error message of level two is pending, the multifunction relay is deactivated.
- When no error message is pending, the multifunction relay is activated.
- A Sunny Island displays a warning. Only the warnings within a cluster are evaluated here.
- The Sunny Island is in operation in a single system.
- The respective cluster is in operation in a cluster system.
- The Sunny Island is in derating in a single system.
- The respective cluster is in derating in a cluster system.

Requirements:

- The technical requirements of the multifunction relay must be met (see Section 17 "Technical Data", page 180).

Cable requirements:

- Copper wire
- Conductor cross-section: 0.2 mm² to 2.5 mm²

1. ⚠ WARNING

Danger to life from electric shock due to incorrect insulation

- Connect the control cable on the Sunny Island to either multifunction relay **Relay1** or **Relay2** (see Section 6.6.5 "Connecting Relay 1 and Relay 2", page 65). Use the **C** and **NO** connections.

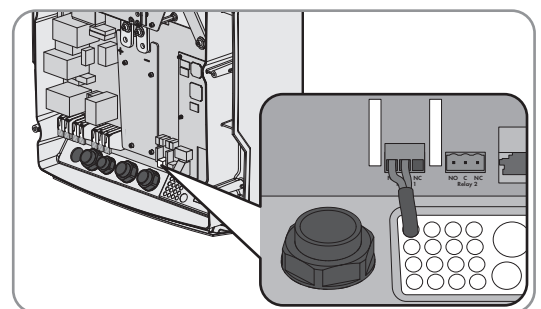

2. Enter the selected configuration into the table of the settings (see Section 7.10.2 "Setting the Functions of the Multifunction Relays", page 108):

| Value | Version |
|---|---|
| Relay is activated when the generator is running | The PV array is running and is connected. |
| Relay is activated when an external source is available | Voltage and frequency of the generator are within the range for connection. |

| Value | Version |
|---|--|
| Relay is activated when utility grid is available | The utility grid is connected in the off-grid system. |
| Relay is deactivated in the event of an error | A Sunny Island displays an error message of level 2 or higher. |
| Relay is activated in the event of a warning | A Sunny Island displays a warning. |
| Relay is activated when the cluster is running | In a single system, the Sunny Island is operating, or in a cluster system, the cluster is operating. |
| Relay is activated in the event of power limitation | In a single system, a Sunny Island is in derating, or in a cluster system, the cluster is in derating. |

6.5.15 Connecting the Battery Room Fan

⚠ QUALIFIED PERSON

If the charging current leads to the emission of gases from the battery, the battery room fan is switched on by the Sunny Island for at least one hour.

Requirements:

- The technical requirements of the multifunction relay must be met (see Section 17 "Technical Data", page 180).

Cable requirements:

- Copper wire
- Conductor cross-section: 0.2 mm² to 2.5 mm²

Procedure:

The battery management of the Sunny Island inverter is able to control one battery room fan for each battery. The following options result for the connection:

- Control a separate battery room fan for each battery.
- Control one battery room fan for all batteries. This is only an option with multicluste systems.

Controlling a separate battery room fan for each battery

1. Ensure that the battery room is sufficiently ventilated in the case of a malfunction of the multifunction relay.

2. **⚠ WARNING**

Danger to life from electric shock due to incorrect insulation

- With single systems or single-cluster systems, connect the battery room fan to a multifunction relay (see Section 6.6.5 "Connecting Relay 1 and Relay 2", page 65) and enter the configuration **Battery compartment fan** in the table of settings (see Section 7.10.2 "Setting the Functions of the Multifunction Relays", page 108).

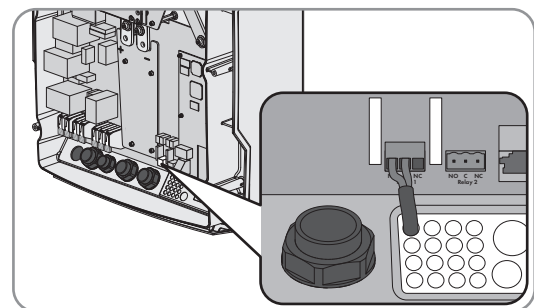

- With a multicluste system, connect one battery room fan to a multifunction relay (see Section 6.6.5 "Connecting Relay 1 and Relay 2", page 65) on one Sunny Island in each cluster and enter the configuration **Battery compartment fan** in the table of settings (see Section 7.10.2 "Setting the Functions of the Multifunction Relays", page 108).

Controlling One Battery Room Fan For All Batteries

1. Ensure that the battery room is sufficiently ventilated in the case of a malfunction of the multifunction relay.

2. **⚠ WARNING**

Danger to life from electric shock due to incorrect insulation

- Connect the battery room fan to one multifunction relay on one Sunny Island of the main cluster (see Section 6.6.5 "Connecting Relay 1 and Relay 2", page 65).

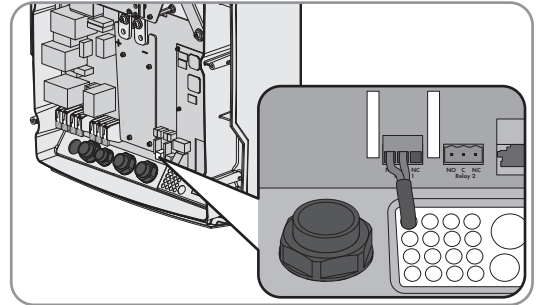

3. Enter the configuration **Battery fan in Multicluster** in the table of settings (see Section 7.10.2 "Setting the Functions of the Multifunction Relays", page 108).

6.5.16 Connecting the Electrolyte Pump for the Battery

⚠ QUALIFIED PERSON

The Sunny Island controls the electrolyte pump for the battery as follows:

- The Sunny Island switches on the electrolyte pump at least once a day.
- The Sunny Island switches on the electrolyte pump a maximum of nine times each day.
- When the battery has been charged to 10% of its rated capacity, the Sunny Island switches the electrolyte pump on for five minutes.

Requirements:

- The technical requirements of the multifunction relay must be met (see Section 17 "Technical Data", page 180).

Cable requirements:

- Copper wire
- Conductor cross-section: 0.2 mm² to 2.5 mm²

Procedure:

1. **⚠ WARNING**

Danger to life from electric shock due to incorrect insulation

- Connect the control cable of the acid circulation to a multifunction relay on the Sunny Island (see Section 6.6.5 "Connecting Relay 1 and Relay 2", page 65).

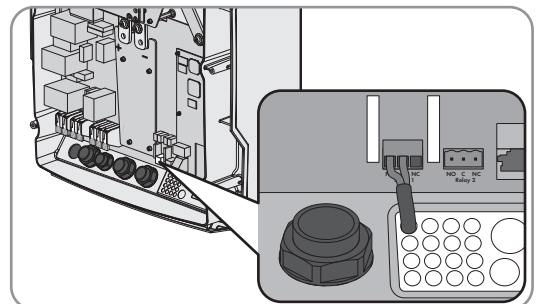

2. For a multicluster system, repeat step 1 for every cluster.

3. Enter the configuration **Electrolyte pump** in the table the settings (see Section 7.10.2 "Setting the Functions of the Multifunction Relays", page 108).

 **Relevant for off-grid systems**

If the battery can no longer take up excess energy in an off-grid system, the power output of the AC sources in the stand-alone grid is limited by the Sunny Island. This means that the excess energy is not used. The Sunny Island allows for the use of excess energy by means of a multifunction relay.

During the constant voltage phase, a multifunction relay is activated and thus controls additional loads that can put any excess energy to good use. As a result of the utilization of excess energy, the Sunny Island has to limit the power output of the AC sources in the stand-alone grid to a lesser extent.

Example: Utilization of excess energy

The energy source of an off-grid system is PV energy. On days with high solar irradiation and low power consumption, the battery cannot take up all of the PV energy during the constant voltage phase. In order to utilize the excess energy, the Sunny Island activates the control of a pump that pumps water into a container for subsequent use.

Requirements:

- The technical requirements of the multifunction relay must be met (see Section 17 "Technical Data", page 180).

Cable requirements:

- Copper wire
- Conductor cross-section: 0.2 mm² to 2.5 mm²

1. **⚠ WARNING**

Danger to life from electric shock due to incorrect insulation

- Connect the control cable for the utilization of excess energy to the multifunction relay on the Sunny Island (see Section 6.6.5 "Connecting Relay 1 and Relay 2", page 65).

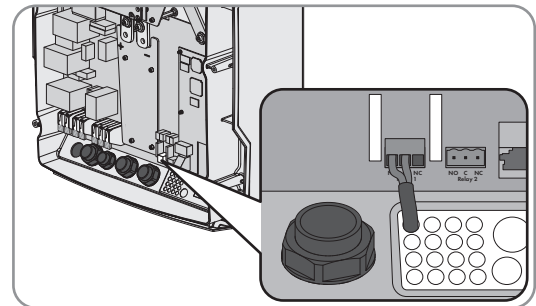

2. Enter the configuration **Control of add. loads** in the table of settings (see Section 7.10.2 "Setting the Functions of the Multifunction Relays", page 108).
3. Set the multifunction relay in accordance with the basic configuration of the system (see Section 7.10.2 "Setting the Functions of the Multifunction Relays", page 108) and set the utilization of excess energy in off-grid systems (see Section 7.7, page 90).

6.5.17 Connecting the Signal Cable of the External Generator Request

⚠ QUALIFIED PERSON

 Relevant for off-grid systems

An external control signal can transmit a generator request to the generator management. If you have configured the generator management for the external generator request, the generator management starts the generator if there is a high level present. The generator management stops the generator if there is a low level. As a result, all generator run times are complied with.

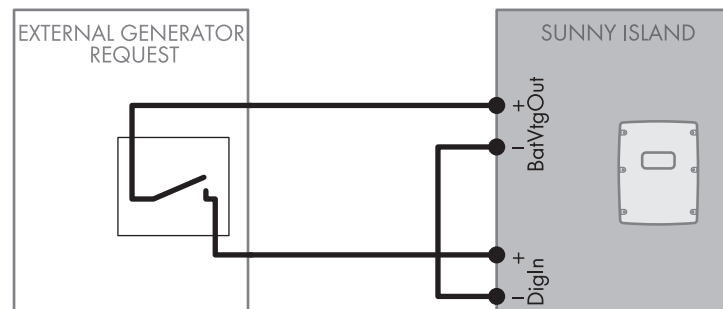

Figure 14: Connection of the control cable of an external generator request (example).

Requirements:

- The technical requirements of the multifunction relay must be met (see Section 17 "Technical Data", page 180).

Cable requirements:

- Copper wire
 - Conductor cross-section: 0.2 mm² to 2.5 mm²
1. On the Sunny Island, thread both insulated conductors through a ferrite included in the scope of delivery. (see Section 6.6.6 "Connecting BatVtgOut, DigIn, BatTMP and BatCur", page 66).
 2. Connect one insulated conductor of the control cable to terminal **BatVtgOut+**.
 3. Connect one insulated conductor of the control cable to terminal **DigIn +**.
 4. Connect terminal **BatVtgOut-** to terminal **DigIn -**. Use the same conductor as in the control cable.

6.6 Connecting the Cables

6.6.1 Connecting the DC Power Cable

⚠ QUALIFIED PERSON

Additionally required material (not included in the scope of delivery):

- Ethanol
- 2 terminal lugs M8, 20 mm to 25 mm wide

Cable requirements:

- Conductor cross-section: 50 mm² to 95 mm²
- Cable diameters: 14 mm to 25 mm
- Only copper cables may be used.
- The DC cables must be sized for the maximum battery voltage and the maximum battery current (see battery manufacturer documentation).

⚠ WARNING

Danger to life due to incompatible lithium-ion battery

An incompatible lithium-ion battery can lead to a fire or an explosion. With incompatible lithium-ion batteries, it is not ensured that battery management is intrinsically safe and will protect the battery.

- Ensure that the lithium-ion batteries are approved for use with the Sunny Island (see technical information "List of Approved Batteries" at www.SMA-Solar.com).
- If no lithium-ion batteries approved for the inverter can be used, lead-acid batteries can be used.
- Verify that the battery complies with locally applicable standards and directives and is intrinsically safe.

Procedure:

1. Ensure that the load-break switch of the battery fuse is open and secured against reconnection.
2. On the Sunny Island, remove all screws of the lower enclosure lid using an Allen key (AF 5) and remove the enclosure lid. Retain the screws and conical spring washers for later use.
3. Clean the contact surfaces of the connections **DC+** and **DC-** using a clean cloth and ethanol cleaning agent and do not touch the contact surfaces after cleaning.
4. Strip off the insulation of the **DC+** cable and mount a terminal lug.
5. Attach two M32 cable glands with counter nuts included in the scope of delivery to the **DC+** and **DC-** enclosure openings (torque: 12 Nm).

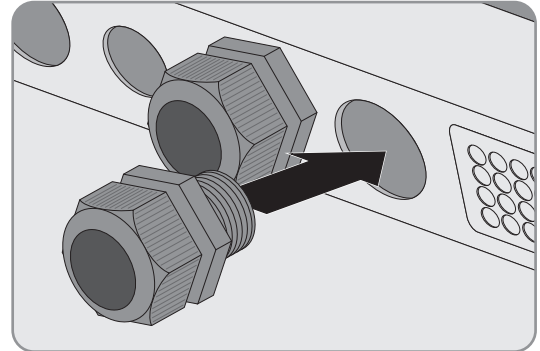

6. Lead the **DC+** cable through the **DC+** cable gland into the Sunny Island.

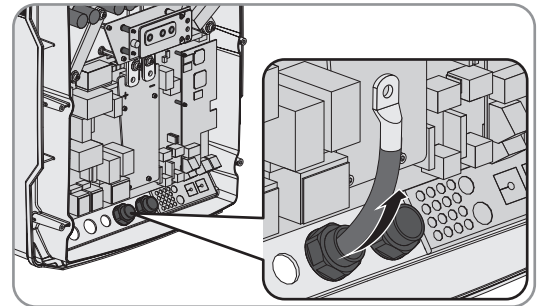

7. **NOTICE****Damage to Sunny Island inverter due to reverse polarity or incorrect terminal lug selection**

If the DC cables are swapped, high currents will flow after the load-break switch has closed and these can damage the Sunny Island.

- Route the **DC+** cable on the side of the protective cover marked with a + symbol.
- Use an Allen key (AF 5) to fasten the **DC+** cable to the **DC+** connection with an M8x20 pan head screw (torque: 12 Nm). Be sure to adhere to the following screw assembly: screw head | spring washer | fender washer | terminal lug | DC connection.

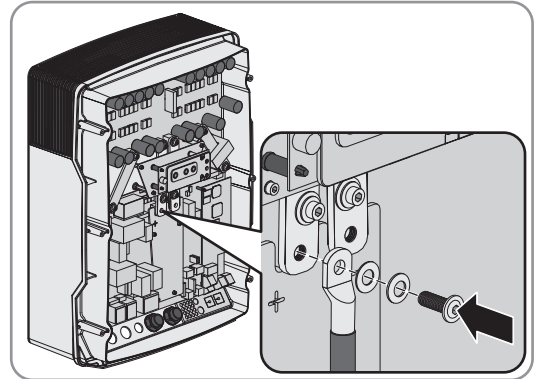

8. Ensure that the entire contact surface of the fender washer is in contact with the terminal lug.

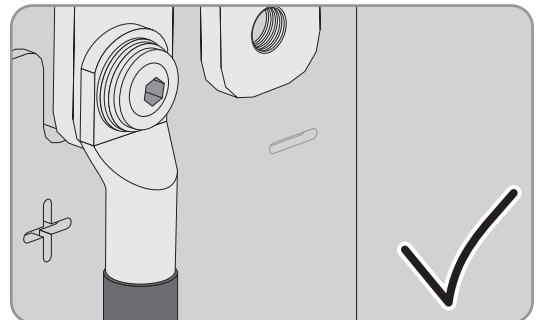

9. Strip off the insulation of the **DC-** cable and mount a terminal lug.

10. Thread the **DC-** cable through the **DC-** cable gland into the Sunny Island.

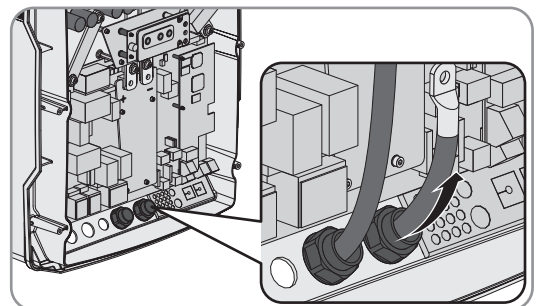

11. Route the **DC-** cable on the side of the protective cover marked with a - symbol.

12. Use an Allen key (AF 5) to fasten the **DC-** cable to the **DC-** connection with an M8x20 pan head screw (torque: 12 Nm). Be sure to adhere to the following screw assembly: screw head | spring washer | fender washer | terminal lug | DC connection.

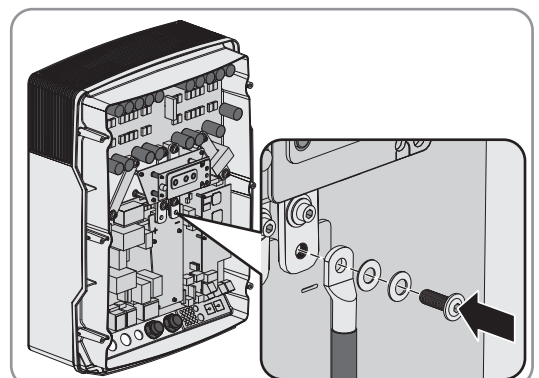

13. Ensure that the entire contact surface of the fender washer is in contact with the terminal lug.

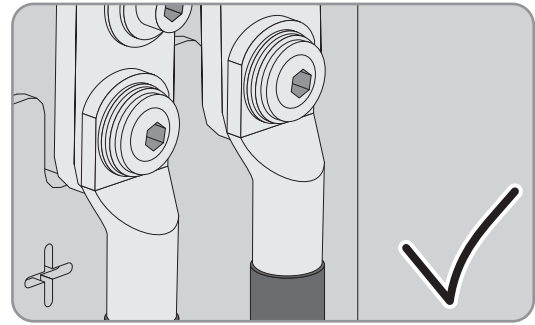

14. Ensure that the seal insert is positioned correctly in the cable gland.
15. Tighten the swivel nuts of the cable glands (torque 4.5 Nm).

6.6.2 Connecting the AC Power Cable

⚠ QUALIFIED PERSON

Always proceed as follows to connect the power cables.

Cable requirements:

- Copper wire
- Recommended conductor cross-section: 10 mm²
- Conductor cross-section: 1.5 mm² to 16 mm²
- Cable diameters: 9 mm to 18 mm

⚠ WARNING

Danger to life from electric shock due to incorrect connection of the neutral conductor

The neutral conductor of the external energy source is firmly connected to the neutral conductor of the Sunny Island inverter on connection **AC2 Gen/Grid N**. Upon disconnection of the external energy source, the Sunny Island only disconnects the line conductor on connection **AC2 Gen/Grid N**. The Sunny Island disconnects all poles from the external energy source on connection **AC2 Gen/Grid N_{TT}**. If the neutral conductor is incorrectly connected on connection **AC2**, the protective functions in the system can fail. This can result in death or serious injury.

- Always connect the neutral conductor to the connection **AC2 Gen/Grid N_{TT}** in systems for increased self-consumption.
- Always connect the neutral conductor to the connection **AC2 Gen/Grid N_{TT}** in battery backup systems.
- Always connect the neutral conductor of the generator to the connection **AC2 Gen/Grid N** in off-grid systems.

⚠ CAUTION

Danger of crushing when locking levers snap shut

The locking levers close by snapping down fast and hard.

- Press the locking levers of the terminal block for the AC cable down with your thumb only.
- Do not grip the entire terminal block for the AC cable.
- Do not place your fingers under the locking levers.

Procedure:

1. Move the levers of the terminals upward at **AC1** or **AC2**.
2. When connecting the cable to connection **AC1**, attach the M25 cable gland to the **AC1** enclosure opening using the counter nut (torque: 7 Nm).

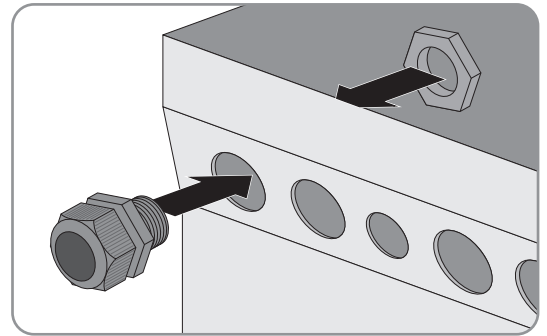

3. When connecting the cable to connection **AC2**, attach the M25 cable gland to the **AC2** enclosure opening using the counter nut (torque: 7 Nm).

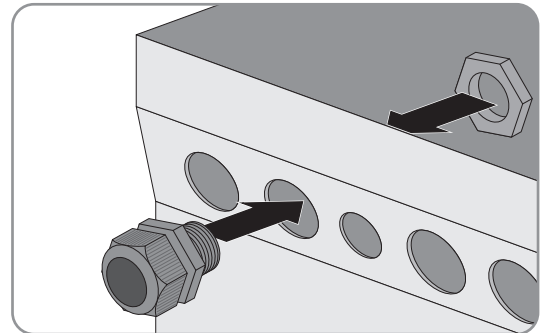

4. Remove the cable jacket and strip off 13 mm of the the insulation of all conductors.
5. Lead the cable through the cable gland into the Sunny Island.
6. Connect the insulated conductors to the terminals **AC1 Loads/SunnyBoys** or **AC2 Gen/Grid**:
 - Insert the neutral conductor as far as it will go into terminal **N** or **NTT** and push the lever down.
 - Insert the line conductor as far as it will go into terminal **L** and push the lever down.
7. Connect the grounding conductor (see Section 6.6.3, page 63).
8. Ensure that the seal insert is positioned correctly in the cable gland.
9. Tighten the swivel nut of the cable gland (torque: 4 Nm).

6.6.3 Connecting the Grounding Conductor

⚠ QUALIFIED PERSON

The Sunny Island must be connected via a grounding conductor on the terminal **AC1** or **AC2** to the ground potential. The conductor cross-section of the grounding conductor must be 10 mm² or larger. If the conductor cross-section is smaller, an additional grounding conductor must connect the Sunny Island with the ground potential.

Additional grounding is fulfilled if the Sunny Island is already grounded due to the grounded battery (see Section 6.4 "Connecting the Grounding Conductor with a Grounded Battery", page 32).

Cable requirements:

- Cross-section of the connected line conductor or (maximum 16 mm²)
- Cable diameters: 7 mm to 14 mm

Procedure:

1. Push the lever of terminal **AC1 Loads/SunnyBoys PE** or **AC2 Gen/Grid PE** upward.
2. Attach the M25 cable gland to the **AC1** or **AC2** enclosure opening using the counter nut (torque: 7 Nm).

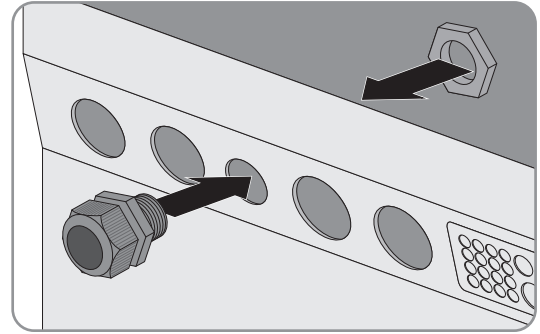

3. Strip off 13 mm of the insulation of the grounding conductor.
4. Lead the cable through the cable gland into the Sunny Island.
5. Thread the grounding conductor through a ferrite included in the scope of delivery.
6. Insert the grounding conductor as far as it will go into terminal **AC1 Loads/SunnyBoys PE** or **AC2 Gen/Grid PE** and move the lever downward.
7. Tighten the swivel nut of the cable gland (torque: 2.6 Nm).

6.6.4 Connecting the Data Cable

⚠ QUALIFIED PERSON

Always proceed as follows to connect data cables.

Procedure:

1. Push the cable feed-through plate out of the enclosure from outside.

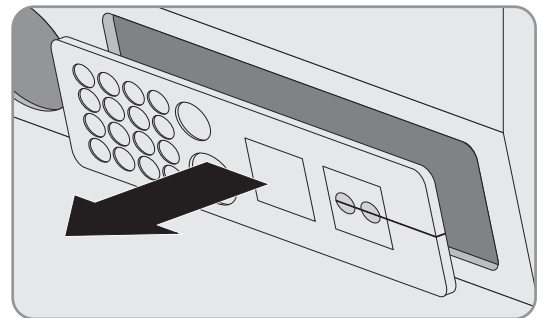

2. Retain the cable feed-through plate for later use.
3. Lead the data cable through the enclosure opening.
4. Connect the data cable.
5. When all data cables are connected, select two cable support sleeves with a suitable number of openings.
6. Open the cable support sleeves and place the cables in the cable support sleeves.

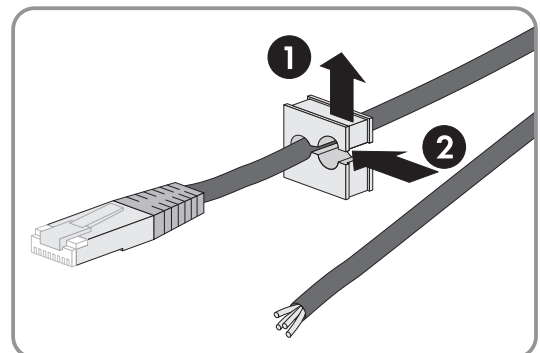

- Open the cable feed-through plate and insert the cable support sleeves into the cable feed-through plate. Position the flat sides of each cable support sleeve on the flat side in the cable feed-through plate.

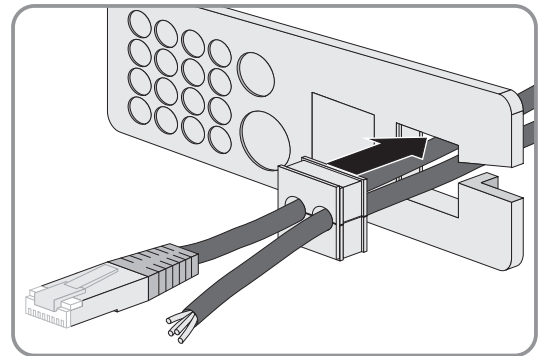

- Hold the cables and push the cable feed-through plate to the enclosure opening of the cable feed-through plate.

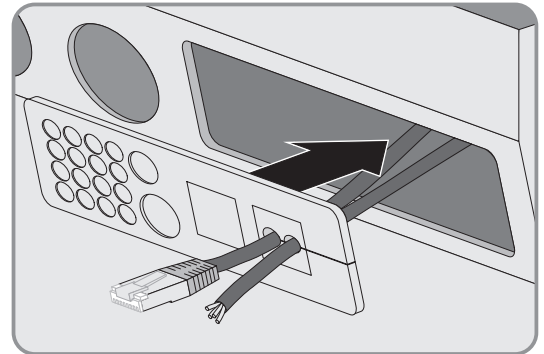

- Hook the cable feed-through plate into the enclosure opening of the cable feed-through plate and press into the enclosure opening.

6.6.5 Connecting Relay 1 and Relay 2

⚠ QUALIFIED PERSON

If you are using a multifunction relay, always connect it as follows:

i Switching Behavior of the Slaves

In case of a fault, the multifunction relays of the slaves switch less reliably than the multifunction relays of the masters. In case of a fault, the slaves wait for the master to confirm the fault.

Additionally required material (not included in the scope of delivery):

- Suitable bootlace ferrules if using stranded wire

Requirements:

- The technical requirements of the multifunction relay must be met (see Section 17 "Technical Data", page 180).

Cable requirements:

- Copper wire
- Conductor cross-section: 0.2 mm² to 2.5 mm²

Procedure:

- Break through a suitable location in the cable feed-through plate with a sharp object.
- Strip 7 mm of the cable insulation.
- Lead the cable through the hole in the cable feed-through plate into the Sunny Island.

4. **⚠ WARNING****Danger to life from electric shock due to incorrect insulation**

High voltage can be present in the control cable. Faulty insulation can result in a conductive connection with other cables or components. Live components can be touched due to this connection. Touching can result in death or serious injury due to electric shock.

- Cut the silicon tube to the length of the cable in the Sunny Island.
- Pull the silicone tube over the cable.

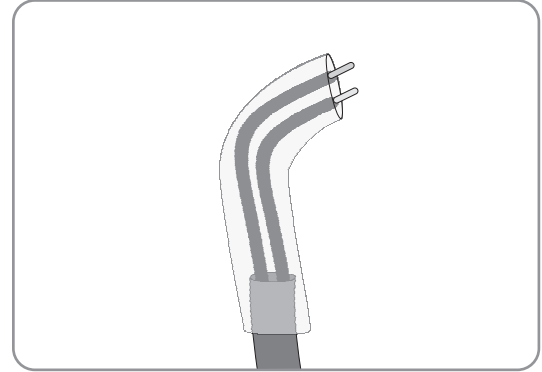

The cable is double-insulated.

- Lead the cable into the Sunny Island making sure that it does not touch any data cables.

5. Connect the insulated conductors to the 3-pole terminal blocks included in the scope of delivery (torque: 0.5 Nm to 0.6 Nm, blade width: 1 mm). Observe the correct assignment of the connections when doing so.

| Connection | Explanation |
|------------|---------------------|
| NC | Closed when idle |
| C | Change-over contact |
| NO | Open when idle |

6. Ensure that the conductors are plugged completely into the terminals up to the insulation.
7. In accordance with the labelling, plug the 3-pole terminal block into the connection **Relay1** or **Relay2** on the inverter until the terminal block audibly snaps into place.

6.6.6 Connecting BatVtgOut, DigIn, BatTMP and BatCur

⚠ QUALIFIED PERSON

Always connect the cables to connections **BatVtgOut**, **DigIn**, **BatTMP** and **BatCur** as follows.

i Information on the connection **BatVtgOut**

The entire DC voltage range of the connections **DC+** and **DC-** is mapped at the connection **BatVtgOut**.

The connection **BatVtgOut** is current-limited and protected against short circuit.

Additionally required material (not included in the scope of delivery):

- Suitable bootlace ferrules if using stranded wire

Cable requirements:

- Copper wire
- Conductor cross-section: 0.2 mm² to 2.5 mm²
- Cable length for **BatVtgOut**, **DigIn** and **BatTemp**: less than 30 m

- Cable length for BatCur: less than 3 m.

Procedure:

1. Break through a suitable location in the cable feed-through plate with a sharp object.
2. Strip 7 mm of the cable insulation.
3. Lead the insulated conductors through the hole in the cable feed-through plate into the Sunny Island.
4. Thread the cable for the connections **BatVtgOut** and **DigIn** through a ferrite included in the scope of delivery.
5. Thread the cable for the connections **BatTmp** and **BatCur** through a ferrite included in the scope of delivery.
6. Connect the insulated conductors to the 4-pole terminal blocks included in the scope of delivery (torque: 0.5 Nm to 0.6 Nm, blade width: 1 mm).
7. Ensure that the conductors are plugged completely into the terminals up to the insulation.
8. In accordance with the labelling, plug the 4-pole terminal block into the connection on the inverter until the terminal block audibly snaps into place.

6.6.7 Connecting ExtVtg

⚠ QUALIFIED PERSON

Always connect the cable to the ExtVtg connection as follows.

Additionally required material (not included in the scope of delivery):

- Suitable bootlace ferrules if using stranded wire

Cable requirements:

- Copper wire
- Conductor cross-section: 0.2 mm² to 2.5 mm²
- The cable length must be less than 3 m.

Procedure:

1. On the Sunny Island, attach the M20 cable gland to the **PE/ExtVtg** enclosure opening with the counter nut (torque: 5 Nm).

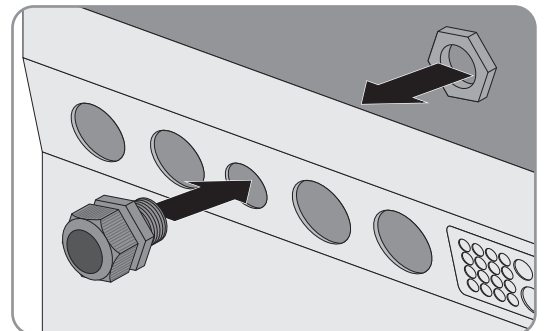

2. Strip 7 mm of the cable insulation.
3. Lead the cable through the cable gland into the Sunny Island.
4. Connect the insulated conductors to the 2-pole terminal blocks included in the scope of delivery (torque: 0.5 Nm to 0.6 Nm, blade width: 1 mm):

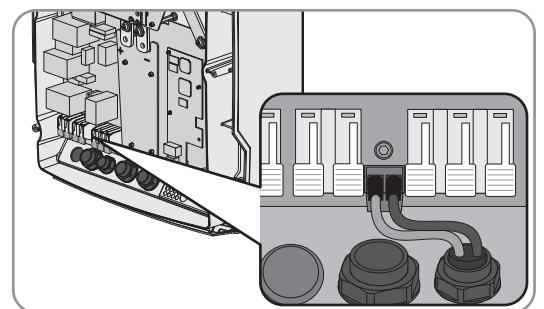

- Connect the line conductor to terminal **ExtVtg L**.

- Connect the neutral conductor to terminal **ExtVtg N**.
5. Ensure that the conductors are plugged completely into the terminals up to the insulation.
 6. In accordance with the labelling, plug the 2-pole terminal block into the connection **ExtVtg** on the inverter until the terminal block audibly snaps into place.
 7. Ensure that the seal insert is positioned correctly in the cable gland.
 8. Tighten the swivel nut of the cable gland (torque: 2.6 Nm).

6.7 Checking the Wiring

⚠ QUALIFIED PERSON

Ensure that you carry out all tests relevant to the system and rectify all detected problems.
Useful hint: Tests can be documented directly in the tables. Cross out all tests not applicable.

Requirement:

- All Sunny Island inverters must be disconnected from all voltage sources (see Section 13, page 132).

Checking the Grounding

| Test point | Test criterion | OK |
|---|--|--------------------------|
| Enclosure opening ExtVtg | Enclosure opening is sealed with a filler plug or M20 cable gland. | <input type="checkbox"/> |
| | | <input type="checkbox"/> |
| | The cable diameter of the cable must be 7 mm to 14 mm for an M20 cable gland. | <input type="checkbox"/> |
| Cable length at the ExtVtg connection | The cable length must be less than 30 m. | <input type="checkbox"/> |
| Conductor cross-section of the grounding conductor at the AC1 and AC2 connections | If one grounding conductor is connected, the conductor cross-section must be at least 10 mm ² . If two grounding conductors are connected, the cross-section of each conductor must be at least 4 mm ² . | <input type="checkbox"/> |
| | The grounding conductor must be threaded through a ferrite. | <input type="checkbox"/> |
| Grounding conductor connection to ground | The grounding conductor must be grounded, e.g., by connection to a grounding busbar or a foundation ground electrode. | <input type="checkbox"/> |
| With a TN system, neutral conductor and grounding conductor connection | Ensure by measuring that there is a conductive connection between the neutral conductor and the grounding conductor. | <input type="checkbox"/> |
| Grounding of the battery | Ensure that the battery is not grounded unintentionally. | <input type="checkbox"/> |
| | If the battery has been grounded intentionally, ensure that the conductor cross-section is sufficient (see Section 6.4 "Connecting the Grounding Conductor with a Grounded Battery", page 32). | |

Checking the Additional Grounding

If the battery is grounded, you must check the additional grounding on the Sunny Island.

| Test point | Test criterion | OK |
|--|--|--------------------------|
| Conductor cross-section for the additional grounding | The conductor cross-section must correspond to the grounding of the battery. | <input type="checkbox"/> |
| | | <input type="checkbox"/> |

| Test point | Test criterion | OK |
|--|--|--------------------------|
| Connection of additional grounding | Hexagon socket screw is screwed tight (torque: 4 Nm to 5.7 Nm). | <input type="checkbox"/> |
| Grounding conductor connection to ground | The grounding conductors must be grounded, e.g., by connection to a grounding busbar or foundation ground electrode. | <input type="checkbox"/> |

Connecting the Sunny Island Inverter

| Test point | Test criterion | OK |
|--------------------------------------|---|--------------------------|
| Enclosure opening for DC | In the cable gland M32, the diameter of the DC power cable must be 14 mm to 25 mm. | <input type="checkbox"/> |
| DC connection | Terminal lugs are pressed on firmly. | <input type="checkbox"/> |
| | The bolted connection for fitting terminal lugs to the DC connection is assembled as follows: head of M8x20 screw spring washer fender washer terminal lug DC connection. | <input type="checkbox"/> |
| | Terminal lugs are firmly fastened on the Sunny Island (torque: 12 Nm). | <input type="checkbox"/> |
| DC power cable | The maximum length of the cables from the battery via the battery fuse to the Sunny Island is 10 m. | <input type="checkbox"/> |
| | The conductor cross-section meets the cable requirements of 50 mm ² to 95 mm ² (for the recommended conductor cross-section, see Section 7.4.1). | <input type="checkbox"/> |
| Battery fuse | Fuse links are matched to the Sunny Island. <ul style="list-style-type: none"> • SI4.4M-12: 100 A • SI6.0H-12: 160 A • SI8.0H-12: 200 A | <input type="checkbox"/> |
| | The cables connected to the battery fuse are tightened with the specified torque (see manufacturer documentation). | <input type="checkbox"/> |
| If installed, battery current sensor | The battery current sensor can be loaded with the maximum DC current (see technical data of the battery current sensor). | <input type="checkbox"/> |

Checking Connections AC1 and AC2 of the Sunny Island Inverter

| Test point | Test criterion | OK |
|--------------------------------|--|--------------------------|
| Enclosure openings AC1 and AC2 | All enclosure openings are sealed with M25 cable glands or filler plugs. | <input type="checkbox"/> |
| | For an M25 cable gland, the cable diameter must be 9 mm to 18 mm. | <input type="checkbox"/> |
| AC1 and AC2 terminals | All contact areas are not insulated. | <input type="checkbox"/> |
| | All terminal levers are in the downward position. | <input type="checkbox"/> |
| | All cables are securely clamped. | <input type="checkbox"/> |

| Test point | Test criterion | OK |
|---|--|--------------------------|
| AC power cable at connection AC1 | The cables are sufficiently protected by circuit breakers. | <input type="checkbox"/> |
| | Trip-capable circuit breakers are installed and additional type A residual-current devices have been installed. Maximum trip-capable circuit breakers: <ul style="list-style-type: none"> • SI4.4M-12: Tripping characteristics B6 • SI6.0H-12: Tripping characteristics B16 or C6 • SI8.0H-12: Tripping characteristics B16 or C6 | <input type="checkbox"/> |
| With a three-phase system, allocation of the Sunny Island inverters | The allocation of the Sunny Island inverters to the line conductors of the stand-alone grid or the Multicluster-Box results in a right-hand rotating magnetic field. The master must be assigned to L1, slave 1 must be assigned to L2, slave 2 must be assigned to L3. | <input type="checkbox"/> |

Checking the Generator Connection

| Test point | Test criterion | OK |
|---|--|--------------------------|
| The connection cables | The conductor cross-section is sufficient for the maximum generator current. | <input type="checkbox"/> |
| | The cables are sufficiently protected by circuit breakers. | <input type="checkbox"/> |
| With a three-phase off-grid system, allocation of the line conductors | The allocation of the Sunny Island inverters to the line conductors of the generator results in a right-hand rotating magnetic field. The master must be assigned to L1, slave 1 must be assigned to L2, slave 2 must be assigned to L3. | <input type="checkbox"/> |
| Grounding | The exposed conductive part of the generator is grounded. | <input type="checkbox"/> |

Checking the Control and Measuring Cables

| Test point | Test criterion | OK |
|--|---|--------------------------|
| Battery temperature sensor if installed | The battery temperature sensor is connected to the terminal BatTmp . | <input type="checkbox"/> |
| | The battery temperature sensor is secured in the middle of the battery-storage system, in the upper third of the battery cell. | <input type="checkbox"/> |
| If installed, the control and measuring cables of the Multicluster-Box | The control and measuring cables are correctly connected (see Multicluster-Box manual). | <input type="checkbox"/> |
| If installed, the measuring cable of the battery current sensor | The measuring cable of the battery current sensor is connected to the terminal BatCur with the correct polarity (see Section 6.5.9 "Connecting the Battery Current Sensor in the Off-Grid System", page 48). | <input type="checkbox"/> |
| Control cable of the load shedding, if installed | The multifunction relay and the load-shedding contactors are correctly wired to each other (see Section 6.5.12 "Connecting Load-Shedding Contactors", page 52). | <input type="checkbox"/> |
| Cables at BatTemp and BatCur | The insulated conductors must be threaded through a ferrite. | <input type="checkbox"/> |
| | The cable length for BatCur must be less than 3 m. | <input type="checkbox"/> |
| | The cable length for BatTmp must be less than 30 m. | <input type="checkbox"/> |

| Test point | Test criterion | OK |
|--|---|--------------------------|
| Cable at BatVtgOut and DigIn | The cable must be threaded through a ferrite. | <input type="checkbox"/> |
| | The cable length must be less than 30 m. | <input type="checkbox"/> |

Checking the Wiring of the Communication Products

| Test point | Test criterion | OK |
|--|--|--------------------------|
| Electricity supply to communication products | The plug-in power supply units are plugged in. | <input type="checkbox"/> |
| | The communication products are connected to an electricity supply. | <input type="checkbox"/> |
| Termination of the communication buses | The communication buses are connected to the first and last device in the bus. | <input type="checkbox"/> |
| Multicluster-Box control and measuring cable (BackupVtgCur) | The cable length must be less than 30 m. | <input type="checkbox"/> |

Checking the System Devices

| Test point | Test criterion | OK |
|-----------------------|---|--------------------------|
| System components | All system devices are correctly connected (see the manuals for the devices). | <input type="checkbox"/> |
| | Ensure by measuring that all system devices are connected with the same ground potential. | <input type="checkbox"/> |
| AC1 connection | After the system-specific connection, the required components are connected at terminal AC1 (see Installation - Quick Reference Guide of the System Used). | <input type="checkbox"/> |
| AC2 connection | After the system-specific connection, the required components are connected at terminal AC2 (see Installation - Quick Reference Guide of the System Used). | <input type="checkbox"/> |

6.8 Sealing and Closing the Sunny Island

⚠ QUALIFIED PERSON

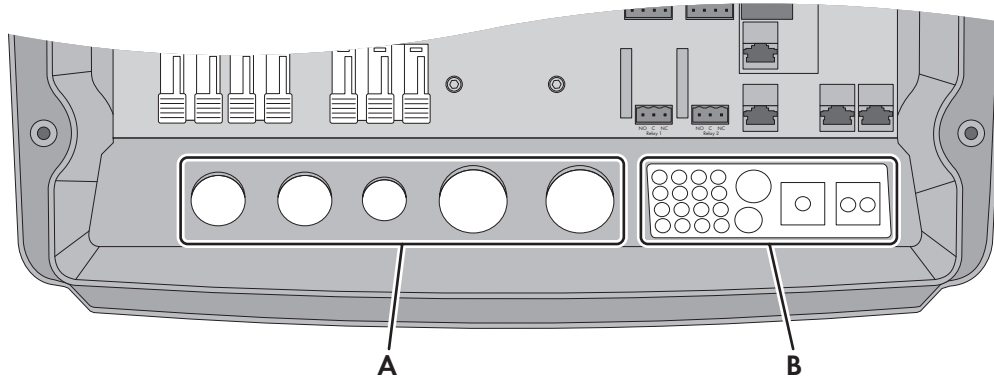
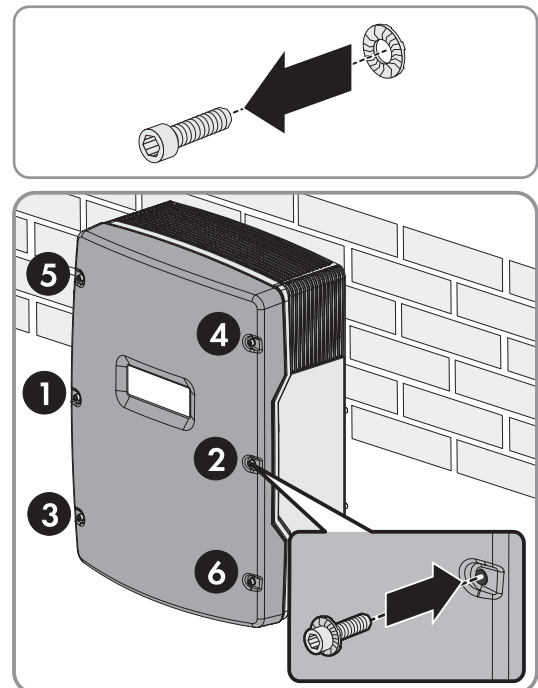

Figure 15: Position of the cable glands and the cable feed-through plate.

| Position | Designation |
|----------|--------------------------|
| A | Cable glands |
| B | Cable feed-through plate |

- Protect the interior of the Sunny Island from dust and moisture:
 - Ensure that the cable glands (A) completely seal the enclosure openings.
 - Seal unused enclosure openings with filler plugs on the cable feed-through plate (B).
 - Seal the cable feed-through plate (B) using the provided sealing compound. The sealing compound must completely seal the cable feed-through plate and the gap between the cable feed-through plate and enclosure.
- Attach one conical spring washer to each screw. Ensure that the grooved side of the conical spring washer points to the screw head. Tip: The scope of delivery of the Sunny Island inverter includes one additional replacement screw with a conical spring washer.
- On the Sunny Island, fasten the enclosure lid following the sequence 1 to 6 using an Allen key (AF 5) (torque: 6 Nm). The teeth of the serrated conical spring washer must press into the enclosure lid. This ensures that the enclosure lid is grounded.



- The teeth of the conical spring washer press into the enclosure lid. This ensures that the enclosure lid is grounded.

6.9 Inserting the Fuse Links in the Fuse Switch-Disconnecter

⚠ QUALIFIED PERSON

1. Ensure that the NH1 fuse link for the fuse switch-disconnector of the battery fuse is correct:

| Device type | Fuse link |
|-------------|-----------|
| SI4.4M-12 | 100 A |
| SI6.0H-12 | 160 A |
| SI8.0H-12 | 200 A |

2. Insert the fuse link and close the battery fuse.

7 Commissioning

7.1 Commissioning Procedure

⚠ QUALIFIED PERSON

Before commissioning the system, you must make various settings. This section describes the procedure and gives an overview of the steps, which must always be performed in the prescribed sequence.

| Procedure | See |
|---|-------------------------|
| 1. Commission the inverter. | Section 7.3, page 75 |
| 2. Establish a connection to the user interface of the inverter. The following connection options are available to choose from: | |
| • Direct connection via WLAN | Section 8.1.1, page 110 |
| • Direct connection via Ethernet | Section 8.1.2, page 111 |
| • Connection via Ethernet in the local network | Section 8.1.3, page 112 |
| 3. Log into the user interface. The installation assistant opens automatically when logging into the user interface for the first time. | Section 8.2, page 112 |
| 4. Set the system-specific basic configuration. Please note that the personal SMA Grid Guard code for changing the grid-relevant parameters must be available after completion of the first ten operating hours (see "Application for SMA Grid Guard Code" at www.SMA-Solar.com). | Section 7.2, page 75 |
| 5. Make individual parameter settings: | |
| • Configure the country data set | Section 7.4, page 76 |
| • Configure the thresholds for systems for increased self-consumption | Section 7.5, page 77 |
| • Battery management settings | Section 7.6, page 77 |
| • Energy management settings | Section 7.7, page 90 |
| • Generator management settings | Section 7.8, page 96 |
| • Off-grid system settings | Section 7.9, page 105 |
| • Multifunction relay settings | Section 7.10, page 107 |
| 6. Complete commissioning | Section 7.11, page 109 |

7.2 Performing Basic Configuration of the Installation Assistant

Once you have logged into the user interface as **Installer**, the installation assistant opens.

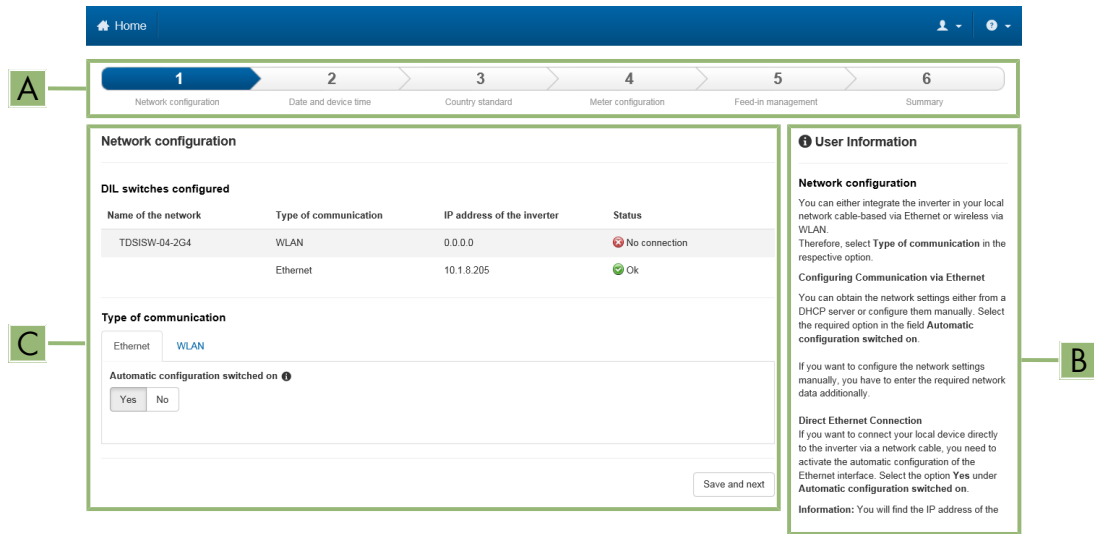

Figure 16: Layout of the installation assistant (example)

| Position | Designation | Description |
|----------|---------------------|--|
| A | Configuration steps | Overview of the installation assistant steps. The number of steps depends on the type of device and the additionally installed modules. The current step is highlighted in blue. |
| B | User information | Information about the current configuration step and the setting options of the configuration step. |
| C | Configuration field | You can make settings in this field. |

Procedure:

1. Select the configuration option **Configuration with Installation Assistant**.
 - The installation assistant will open.
2. Follow the installation assistant steps and make the settings appropriate for your system.
3. For every setting made in a step, select [**Save and next**].
 - In the last step, all made settings are listed in a summary.
4. To save the settings to a file, select [**Export a summary**] and save the file on your computer, tablet PC or smartphone.
5. To correct settings you made, select [**Back**], navigate to the desired step, correct settings and select [**Save and continue**].
6. Once all settings are correct, select [**Next**] in the summary.
 - The start page of the user interface opens.

7.3 Commissioning the Inverter

⚠ QUALIFIED PERSON

Requirements:

- All circuit breakers in the AC distribution board must be open.

- All Sunny Island inverters must be connected correctly (see Section 6.7, page 68).
- All Sunny Island inverters must be closed (see Section 6.8, page 72).
- All Sunny Island inverters must be switched off.
- The fuse switch-disconnector of the battery fuse must be closed (see Section 6.9, page 73).

Procedure:

1. Switching on the Sunny Island:

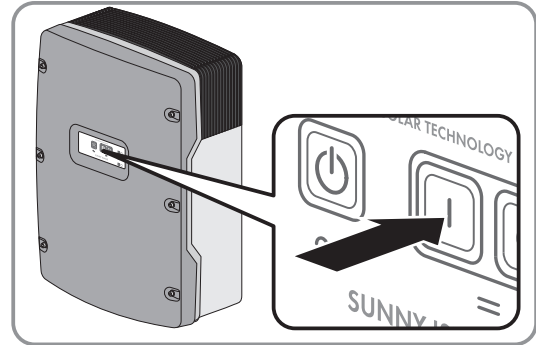

- For systems with one Sunny Island, press the "On" button.
 - For systems with three Sunny Island inverters, press and hold the "On" button on the master until an acoustic signal sounds.
 - For multicluster systems, press and hold the "On" button on each master until an acoustic signal sounds.
2. Establish a connection to the user interface of the inverter (see Section 8.1, page 110).

7.4 Configuring the Country Data Set

⚠ QUALIFIED PERSON

During configuration of a storage or battery-backup system the inverter is configured to the country data set for VDE-AR-N 4105.

i The country data set must be set correctly.

If you select a country data set which is not valid for your country and purpose, it can cause a disturbance in the PV system and lead to problems with the grid operator. When selecting the country data set, you must always observe the locally applicable standards and directives as well as the properties of the PV system (e.g. PV system size, grid-connection point).

- If you are not sure which country data set is valid for your country or purpose, contact your grid operator for information on which country data set is to be configured.

The basic procedure for changing operating parameters is explained in another section (see Section 9.2 "Changing Operating Parameters", page 119).

Procedure:

- In the parameter group **Grid monitoring > Grid monitoring** select the parameter **Set country standard** and set the required country data set.

7.5 Changing Thresholds for Systems for Increased Self-Consumption



Relevant for systems connected to the utility grid

The Sunny Island meets the requirements of the application rule "VDE-AR-N 4105:2011-08 - Power generation systems connected to the low-voltage distribution network - Technical minimum requirements for the connection to and parallel operation with low-voltage distribution networks". In the Sunny Island, the application rule is defined as the industry standard country data set **VDE-AR-N4105**.

In certain countries, the settings may need to be modified for connection of the Sunny Island inverter to the utility grid.

Procedure:

- If the Sunny Island may be operated on the utility grid and a change is necessary, change the configuration of the Sunny Island in accordance with the system description of the selected Sunny Island system (see www.SMA-Solar.com).

7.6 "Battery Management"

7.6.1 Safety When Setting the Battery Management Parameters

This section contains safety information to be observed when configuring the battery management. To prevent property damage and to ensure the long-term operation of the product, read this section carefully and observe all safety information.

NOTICE

Damage to the battery due to incorrect settings

The set battery parameters influence the charging behavior of the inverter. The battery can be damaged by incorrect settings of the battery type, nominal voltage and capacity parameters.

- Set the correct battery type as well as the correct values for nominal voltage and battery capacity when configuring.
- Ensure that the values recommended by the manufacturer are set for the battery (refer to the technical data of the battery in the manufacturer documentation).

7.6.2 Adjusting the Battery Management to the Battery

⚠ QUALIFIED PERSON

You will find further information on battery management and the charging processes of the Sunny Island for lead-acid batteries in the technical information "Battery Management" at www.SMA-Solar.com.

The basic procedure for changing operating parameters is explained in another section (see Section 9.2 "Changing Operating Parameters", page 119).

Procedure:

1. Select **Battery > Charge**.
2. Set the parameter **Maximum charging current** to the maximum battery charging current recommended by the battery manufacturer.
3. Set the parameters for boost charge.
 - Set the parameter **Battery boost charge time** to the boost charge absorption time recommended by the battery manufacturer.
 - Set the parameter **Cell charge nominal voltage for boost charge** to the cell voltage setpoint recommended by the battery manufacturer for boost charge.
4. Set the parameters for full charge.

- Set the parameter **Battery full charge time** to the full charge absorption time recommended by the battery manufacturer.
 - Set the parameter **Cycle time full charge** to the full charge cycle time recommended by the battery manufacturer.
 - Set the parameter **Cell charge nominal voltage for full charging** to the cell voltage setpoint recommended by the battery manufacturer for full charge.
5. Set the parameters for equalization charge.
- Set the parameter **Battery equalization charge time** to the equalization charge absorption time recommended by the battery manufacturer.
 - Set the parameter **Cycle time equalization charge** to the equalization charge cycle time recommended by the battery manufacturer.
 - Set the parameter **Cell charge nominal voltage for equalization charge** to the cell voltage setpoint recommended by the battery manufacturer for equalization charge.

7.6.3 Changing the Battery Usage Through Battery-Backup Systems without Increased Self-Consumption

QUALIFIED PERSON



Relevant for systems connected to the utility grid

Adjusting the default values

The parameters for battery usage are set automatically to reasonable values during basic configuration for the respective system. The parameter values can be adjusted if there are special requirements for the system or the battery.

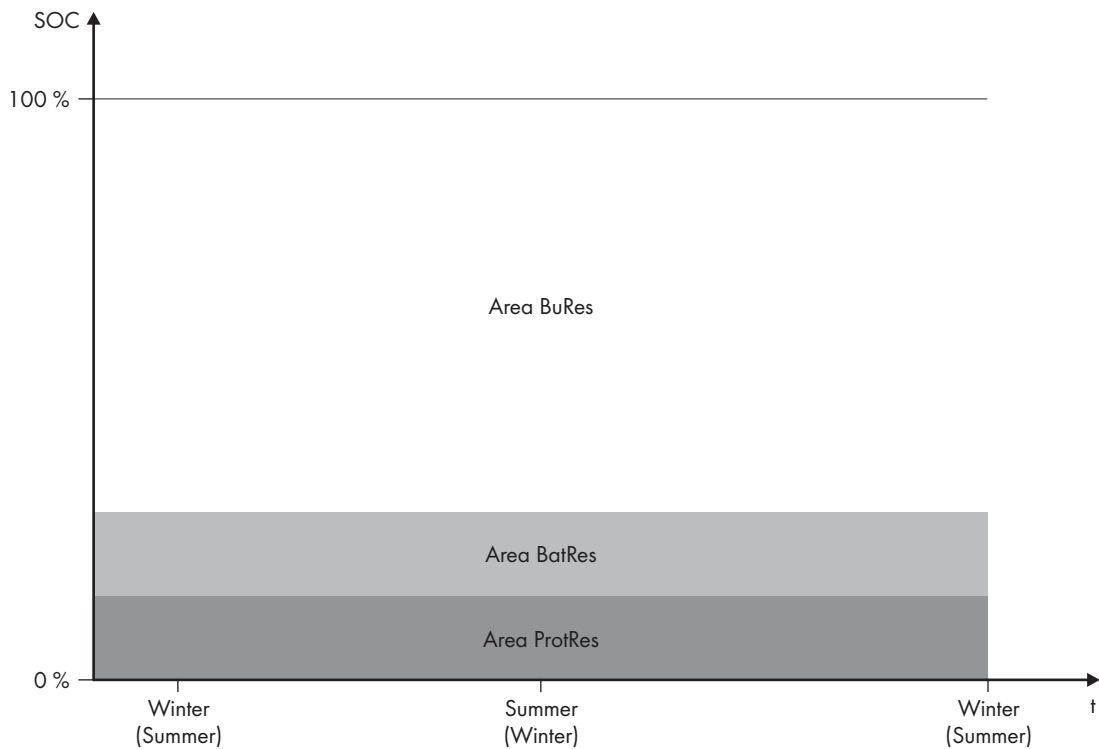

Figure 17: State of charge ranges of the battery according to the time of year (example)

| Range | Explanation of the range and parameters | Behavior of the Sunny Island inverter |
|---------|---|--|
| BuRes | Range for the battery backup system function Battery > Areas of application > Minimum width of backup power area | The Sunny Island uses this range for supplying the battery-backup grid when the utility grid fails. When the utility grid is available again, the battery is charged by the Sunny Island with nominal power from the utility grid. |
| BatRes | Range for protection against deep discharge This range can only be reached when the utility grid fails. Battery > Areas of application > Minimum width of deep discharge protection area | The Sunny Island switches into standby mode. The Sunny Island starts up every two hours and attempts to charge the battery with PV energy. If the battery cannot be charged, the Sunny Island switches back to standby mode. When the utility grid is available again, the battery is charged by the Sunny Island with nominal power from the utility grid. |
| ProtRes | Range for protection in the event of deep discharge This range can only be reached when the utility grid fails. Battery > Areas of application > Lower lmt deep disch. protect area prior shutdown | When this range is reached, the Sunny Island switches off in order to protect the battery. When the utility grid is available again, the system must be charged manually (see Sunny Island operating manual). |

The following ranges result from the parameter default values:

| Range | Lead-acid battery | Lithium-ion battery |
|-------|-------------------|---------------------|
| BuRes | 15% to 100% | 13% to 100% |

| Range | Lead-acid battery | Lithium-ion battery |
|---------|-------------------|---------------------|
| BatRes | 10% to 15% | 3% to 13% |
| ProtRes | 0% to 10% | 0% to 3% |

i Procedure for multicluster systems with battery-backup grid

With the Multicluster-Box 12 (MC-Box-12.3-20) and the NA-Box or Grid-Connect-Box, multicluster systems with battery-backup grid can be installed (see Multicluster-Box and NA-Box / Grid-Connect-Box documentation).

- In a multicluster system with battery-backup grid, set the ranges of battery state of charge for each cluster to the same values.

The basic procedure for changing operating parameters is explained in another section (see Section 9.2 "Changing Operating Parameters", page 119).

Procedure:

1. Select **Battery > Areas of application**.
2. Set the following parameters for increased self-consumption:

| Parameter | Value |
|--|--|
| Rise in self-consumption switched on | Yes |
| Lower lmt deep disch. protect area prior shut-down | Range for protection during deep discharge as a percentage of the battery capacity |
| Minimum width of deep discharge protection area | Range for protection against deep discharge as a percentage of the battery capacity |
| Minimum width of backup power area | Range for battery-backup function If all ranges combined do not amount to 100%, the BuRes range will be increased automatically. |
| Season operation active | No |

7.6.4 Battery Usage through Systems for Increased Self-Consumption

7.6.4.1 Seasonal Adjustment of the Battery Usage



Relevant for systems connected to the utility grid

The options for increased self-consumption depend to a large extent on the battery and on the availability of PV energy. In order to use the battery optimally, you can adjust the depth of discharge of the battery to the application.

In many regions, the PV energy available largely depends on the season and the hours of sunshine. On short days with few hours of sunlight, the Sunny Island cannot charge the battery fully. Lead-acid batteries in particular age faster due to low charging over a long period. Therefore, it is better if the battery is not discharged too much by the Sunny Island on short days. On short days, there is insufficient PV energy to charge the battery. On long days with many hours of sunlight, the Sunny Island can usually charge the battery fully. On such days, it is better to use as much of the battery capacity as possible for increasing self-consumption.

The discharge behavior can be adjusted to the location and time by the Sunny Island. Furthermore, you can set a seasonal adjustment (**Battery > Areas of application > Season operation active**). The Sunny Island only uses a small portion of battery capacity for increased self-consumption on short days when adjustment is activated. The Sunny Island uses a large portion of the battery capacity for the increased self-consumption on long days. The seasonal adjustment prolongs the electrical endurance of the battery in regions where the available PV energy is largely dependent on the season.

7.6.4.2 Changing the Battery Usage Through Systems for Increased Self-Consumption Without a Battery Backup Grid

QUALIFIED PERSON



Relevant for systems connected to the utility grid

Adjusting the default values

The parameters for battery usage are set automatically to reasonable values during basic configuration for the respective system. The parameter values can be adjusted if there are special requirements for the system or the battery.

In systems for increased self-consumption, one range can be adjusted seasonally:

- Increased self-consumption range (SlfCsmP)

You determine the percentage of the battery capacity that is to be used for increased self-consumption on the shortest day of the year.

The longer the days become, the more the SlfCsmP range increases automatically and the range for protection against deep discharge (BatRes) decreases. The range for increased self-consumption reaches its maximum on the longest day. This results in the seasonal progression of the ranges.

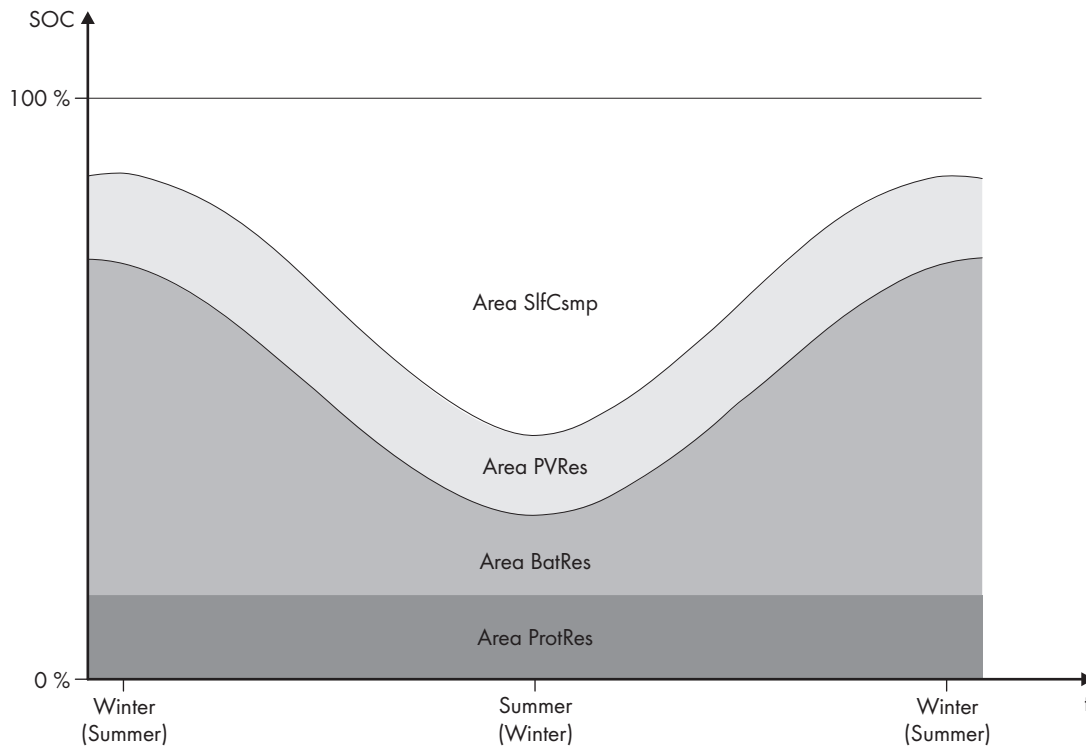

Figure 18: State of charge ranges of the battery according to the time of year (example)

| Range | Explanation of the range and parameters | Behavior of the Sunny Island inverter |
|---------|--|--|
| SlfCsmP | <p>Range for increased self-consumption</p> <p>The SlfCsmP range applies to the shortest day of the year with seasonal adjustment (see Section 7.6.4.1, page 80). When seasonal adjustment is deactivated, only the SlfCsmP range is used and the BatRes range increased accordingly.</p> <p>Battery > Areas of application > Minimum width of backup power area</p> | <p>The Sunny Island uses the battery for increased self-consumption.</p> |
| PVRes | <p>Range for maintaining the state of charge of the battery</p> <p>The range size is constant year-round.</p> <p>Battery > Areas of application > Area width for conserving battery state of charge</p> | <p>Excess PV energy is used for conserving the battery charge. If no excess PV energy is available, the Sunny Island switches to energy saving mode. When the state of charge reaches the BatRes range limit, the Sunny Island charges the battery up to half of the PVRes range from the utility grid. To do so, the Sunny Island charges the battery with maximum efficiency at 25% of the nominal power of the Sunny Island inverter.</p> |

| Range | Explanation of the range and parameters | Behavior of the Sunny Island inverter |
|---------|---|---|
| BatRes | <p>Range for protection against deep discharge</p> <p>This range can only be reached when the utility grid fails. The BatRes range applies to the longest day of the year with seasonal adjustment (see Section 7.6.4.1, page 80). If seasonal adjustment is deactivated, the BatRes range is increased accordingly.</p> <p>Battery > Areas of application > Minimum width of deep discharge protection area</p> | If a utility grid is available, the Sunny Island charges the battery using nominal power from the utility grid. |
| ProtRes | <p>Range for protection in the event of deep discharge</p> <p>This range can only be reached when the utility grid fails.</p> <p>Battery > Areas of application > Lower lmt deep disch. protect area prior shutdown</p> | <p>When this range is reached, the Sunny Island switches off in order to protect the battery.</p> <p>When the utility grid is available again, the system must be charged manually (see Sunny Island operating manual).</p> |

The following ranges result from the parameter default values:

| Range | Lead-acid battery | | Lithium-ion battery | |
|-------------|-------------------|---------------|---------------------|---------------|
| | Shortest day* | Longest day** | Shortest day* | Longest day** |
| MinSlfCsmpl | 65% to 100% | 40% to 100% | 30% to 100% | 10% to 100% |
| PVRes | 60% to 65% | 40% to 45% | 25% to 30% | 5% to 10% |
| BatRes | 10% to 60% | 10% to 40% | 3% to 13% | 3% to 5% |
| ProtRes | 0% to 10% | 0% to 10% | 0% to 3% | 0% to 3% |

* December 21 (northern hemisphere) or June 21 (southern hemisphere)

** June 21 (northern hemisphere) or December 21 (southern hemisphere)

The following ranges result from deactivating seasonal adjustment with the default values of the parameters:

| Range | Lead-acid battery | Lithium-ion battery |
|-------------|-------------------|---------------------|
| MinSlfCsmpl | 65% to 100% | 30% to 100% |
| PVRes | 60% to 65% | 25% to 30% |
| BatRes | 10% to 60% | 3% to 25% |
| ProtRes | 0% to 10% | 0% to 3% |

The basic procedure for changing operating parameters is explained in another section (see Section 9.2 "Changing Operating Parameters", page 119).

Requirement:

- The system is not a battery backup system

Procedure:

1. Select **Device > Device > Self-consumption**.
2. Set the parameter **Rise in self-consumption switched on** to **Yes**.

3. Select **Battery > Areas of application >**.
4. Set the following parameters for the battery usage:

| Parameter | Value |
|--|---|
| Lower lmt deep disch. protect area prior shut-down | Range for protection during deep discharge as a percentage of the battery capacity |
| Minimum width of deep discharge protection area | Range for protection against deep discharge on the longest day of the year as a percentage of the battery capacity The range remains constant year-round when seasonal adjustment is deactivated. |
| Area width for conserving battery state of charge | Range for maintaining the state of charge of the battery as a percentage of the battery capacity |
| Minimum width of own consumption area | Range for increasing self-consumption on the shortest day of the year as a percentage of the battery capacity When seasonal adjustment is deactivated, this value is used year-round for increased self-consumption. |
| Highest-yielding month for battery utilization range: | North for northern hemisphere* South for southern hemisphere** |
| Season operation active | No for no seasonal adjustment or Yes for seasonal adjustment |

* Set the value to **North** when June is the month with the highest yield.

** Set the value to **South** when December is the month with the highest yield.

- The parameters for battery usage have been set.
- A parameter cannot be adjusted?
 - All ranges combined result in a value greater than 100%.
 - Ensure that all ranges have been set correctly.

7.6.4.3 Changing the Battery Usage through Battery-Backup Systems with Increased Self-Consumption

QUALIFIED PERSON



Relevant for systems connected to the utility grid

Adjusting the default values

The parameters for battery usage are set automatically to reasonable values during basic configuration for the respective system. The parameter values can be adjusted if there are special requirements for the system or the battery.

Two ranges can be adjusted seasonally in battery-backup systems with increased self-consumption:

- Range for increased self-consumption (MinSlfCsmP)
You determine the percentage of the battery capacity that is to be used for increased self-consumption on the shortest day of the year.
- Range for the battery backup system function (BURes)
You specify the percentage of the battery capacity that is to be used for the battery backup system function on the longest day.

The longer the days become, the more the SlfCsmP range automatically increases and the BURes range decreases. The range for increased self-consumption reaches its maximum on the longest day. This results in the seasonal progression of the ranges.

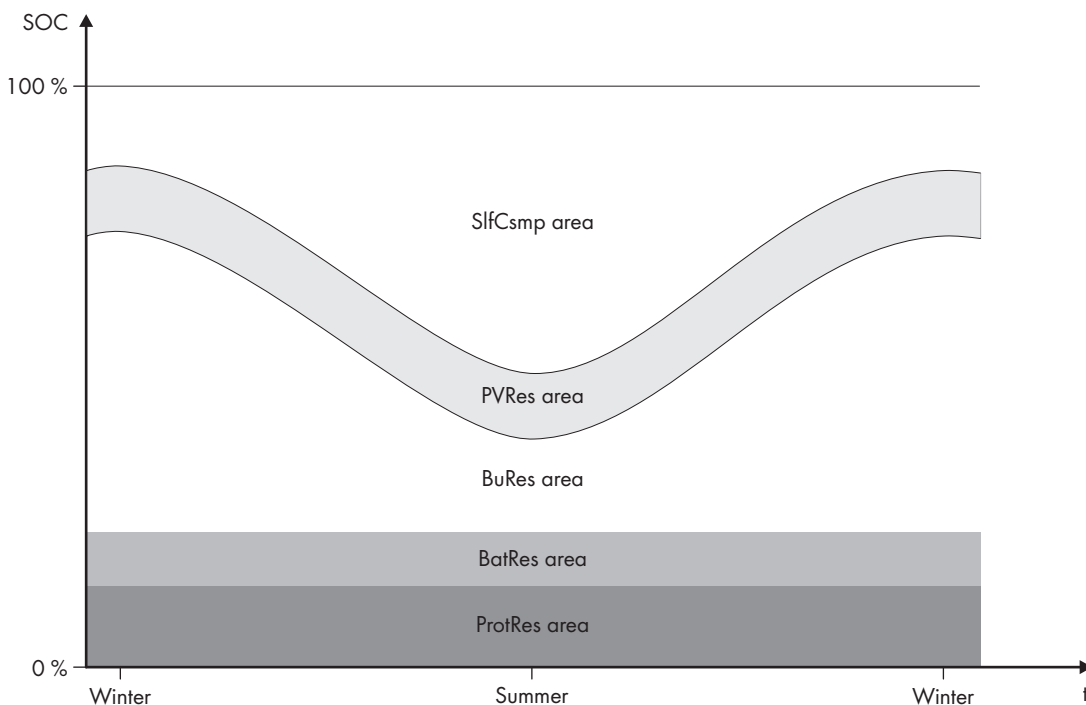

Figure 19: State of charge ranges of the battery according to the time of year (example)

| Range | Explanation of the range and parameters | Behavior of the Sunny Island inverter |
|---------|---|--|
| SlfCsmP | <p>Range for increased self-consumption</p> <p>The SlfCsmP range applies to the shortest day of the year with seasonal adjustment (see Section 7.6.4.1, page 80). When seasonal adjustment is deactivated, only the SlfCsmP range is used and the BURes range increased accordingly.</p> <p>Battery > Areas of application > Minimum width of backup power area</p> | <p>The Sunny Island uses the battery for increased self-consumption.</p> |

| Range | Explanation of the range and parameters | Behavior of the Sunny Island inverter |
|---------|--|--|
| PVRes | <p>Range for maintaining the state of charge of the battery The range size is constant year-round.</p> <p>Battery > Areas of application > Area width for conserving battery state of charge</p> | <p>Excess PV energy is used for conserving the battery charge. If no excess PV energy is available, the Sunny Island switches to energy saving mode. When the state of charge reaches the BatRes range limit, the Sunny Island charges the battery up to half of the PVRes range from the utility grid. To do so, the Sunny Island charges the battery with maximum efficiency at 25% of the nominal power of the Sunny Island inverter.</p> |
| BuRes | <p>Range for the battery backup system function</p> <p>The BURes range applies to the longest day of the year with seasonal adjustment (see Section 7.6.4.1, page 80). When seasonal adjustment is deactivated, only the minimum range is used and the SlfCsmP range increased accordingly.</p> <p>Minimum width of backup power area</p> | <p>The Sunny Island uses this range for supplying the battery-backup grid when the utility grid fails. When the utility grid is available again, the battery is charged by the Sunny Island with nominal power from the utility grid.</p> |
| BatRes | <p>Range for protection against deep discharge This range can only be reached when the utility grid fails.</p> <p>Battery > Areas of application > Minimum width of deep discharge protection area</p> | <p>The Sunny Island switches into standby mode. The Sunny Island starts up every two hours and attempts to charge the battery with PV energy. If the battery cannot be charged, the Sunny Island switches back to standby mode.</p> <p>When the utility grid is available, the Sunny Island charges the battery with nominal power from the utility grid.</p> |
| ProtRes | <p>Range for protection in the event of deep discharge This range can only be reached when the utility grid fails.</p> <p>Battery > Areas of application > Lower lmt deep disch. protect area prior shutdown</p> | <p>When this range is reached, the Sunny Island switches off in order to protect the battery. When the utility grid is available again, the system must be charged manually (see Sunny Island operating manual).</p> |

| Range | Lead-acid battery | | Lithium-ion battery | |
|---------|-------------------|---------------|---------------------|---------------|
| | Shortest day* | Longest day** | Shortest day* | Longest day** |
| SlfCsmP | 65% to 100% | 40% to 100% | 30% to 100% | 28% to 100% |
| PVRes | 60% to 65% | 40% to 45% | 25% to 30% | 23% to 28% |
| BURes | 15% to 60% | 15% to 40% | 13% to 25% | 13% to 23% |
| BatRes | 10% to 15% | 10% to 15% | 3% to 13% | 3% to 13% |
| ProtRes | 0% to 10% | 0% to 10% | 0% to 3% | 0% to 3% |

* December 21 (northern hemisphere) or June 21 (southern hemisphere)

** June 21 (northern hemisphere) or December 21 (southern hemisphere)

The following ranges result from deactivating seasonal adjustment with the default values of the parameters:

| Range | Lead-acid battery | Lithium-ion battery |
|---------|-------------------|---------------------|
| SlfCsmP | 65% to 100% | 30% to 100% |
| PVRes | 60% to 65% | 25% to 30% |
| BURes | 10% to 60% | 13% to 25% |
| BatRes | 10% to 15% | 3% to 13% |
| ProtRes | 0% to 10% | 0% to 3% |

i Procedure for multicluster systems with battery-backup grid

With the Multicluster-Box 12 (MC-Box-12.3-20) and the NA-Box or Grid-Connect-Box, multicluster systems with battery-backup grid can be installed (see Multicluster-Box and NA-Box / Grid-Connect-Box documentation).

- In a multicluster system with battery-backup grid, set the ranges of battery state of charge for each cluster to the same values.

The basic procedure for changing operating parameters is explained in another section (see Section 9.2 "Changing Operating Parameters", page 119).

Procedure:

1. Select **Device > Device > Self-consumption**.
2. Set the parameter **Rise in self-consumption switched on** to **Yes**.
3. Select **Battery > Areas of application >**.
4. Set the following parameters for the battery usage:

| Parameter | Value |
|---|---|
| Lower lmt deep disch. protect area prior shut-down | |
| Minimum width of deep discharge protection area | Range for protection against deep discharge as a percentage of the battery capacity |
| Minimum width of backup power area | Range for the battery backup system function on the longest day of the year as a percentage of the battery capacity The range remains constant year-round when seasonal adjustment is deactivated. |
| Area width for conserving battery state of charge | Range for maintaining the state of charge of the battery as a percentage of the battery capacity |
| Minimum width of own consumption area | Range for increasing self-consumption on the shortest day of the year as a percentage of the battery capacity When seasonal adjustment is deactivated, this value is used year-round for increased self-consumption. |

| Parameter | Value |
|--|--|
| Highest-yielding month for battery utilization range: | North for northern hemisphere* |
| | South for southern hemisphere** |
| Highest-yielding month for battery utilization range: | No for no seasonal adjustment |
| | or |
| | Yes for seasonal adjustment |

* Set the value to **North** when June is the month with the highest yield.

** Set the value to **South** when December is the month with the highest yield.

- The parameters for battery usage have been set.
- A parameter cannot be adjusted?
 - All ranges combined result in a value greater than 100%.
 - Ensure that all ranges have been set correctly.

7.6.5 Changing the Battery Protection Mode in Off-Grid Systems

QUALIFIED PERSON

Relevant for off-grid systems

The basic procedure for changing operating parameters is explained in another section (see Section 9.2 "Changing Operating Parameters", page 119).

Function of the battery protection mode:

The battery protection mode protects the battery.

If the state of charge (SOC) of the battery falls below the thresholds, battery protection mode is activated. In battery protection mode, the Sunny Island switches to standby mode or switches itself off. The battery protection mode has three levels. One state of charge threshold can be set for each level. Levels 1 and 2 of the battery protection mode have specific start and end times and are therefore dependent on the time of day (see Section 9.8.2 "Setting Time-Dependent Functions", page 123).

- Level 1

If the state of charge falls below the threshold for level 1, the Sunny Island switches to standby between the start time and end time. This way you can specify preferred times for the Sunny Island to be switched off if an energy deficit occurs.

- Level 2

If the SOC drops below the threshold for level 2, the Sunny Island switches to standby. Use the start time and end time to define the time window in which no energy is anticipated from AC sources. Outside this time window, the Sunny Island starts up every two hours to charge the battery. If no energy is available to charge the battery, the Sunny Island remains on standby.

This means that, for example, in stand-alone grids with PV inverters, you can specify that the Sunny Island does not start up at night, preventing it from consuming energy from the battery.

- Level 3

If the state of charge falls below the threshold for level 3, the Sunny Island switches itself off. This protects the battery against deep discharge and severe damage. To charge the battery again, the Sunny Island must be switched on and started manually.

At all three levels, the Sunny Island will only switch to standby mode or switch itself off if no charging current has flowed in the battery for at least five minutes.

Recharging the battery with an external energy source:

In levels 1 and 2 of battery protection mode, you can charge the battery at any time with an external energy source. If a voltage is present on connection **AC2**, the Sunny Island exits standby mode.

If the Sunny Island has switched to level 3 of battery protection mode by itself, you must charge the battery in emergency charge mode (see the Sunny Island inverter operating manual).

Time settings:

The start time and the end time can be configured for battery protection mode levels 1 and 2.

If the state of charge falls below the threshold for level 1, the Sunny Island switches to standby between the start time and end time.

If the state of charge drops below the SOC threshold for level 2, the Sunny Island switches to standby between the start time and the end time. The Sunny Island attempts to charge the battery in the remaining time.

Procedure:

1. Select **Battery > Protection mode**.
2. Set the parameter **Start time of battery protection mode** to the desired start times for level 1 and 2.
3. Set the parameter **End time of battery protection mode** to the desired end times for level 1 and 2.
4. Set the parameter **Battery state of charge for protection mode** to the desired SOC threshold for level 1, 2 and 3.

7.6.6 Configuring the Resistance of the Battery Cable

⚠ QUALIFIED PERSON

You can optimize the battery management if you set the resistance of the battery cable in expert mode.

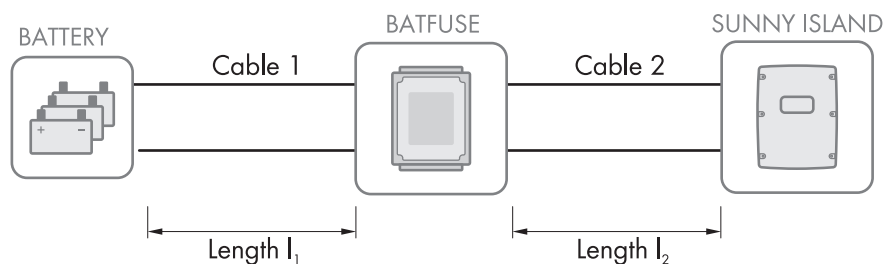

Figure 20: Designation of the cable

The resistance of the battery cable is the sum of the resistance of cable 1, the battery fuse and the resistance of cable 2.

The basic procedure for changing operating parameters is explained in another section (see Section 9.2 "Changing Operating Parameters", page 119).

Procedure:

1. Calculate the individual cable resistances. Use the following formula:

$R_{Cu}(l, A)$ = resistance of the cable

ρ = specific resistance for copper ($\rho = 0.018 \Omega \cdot \text{mm}^2/\text{m}$)

l = total length of the conductor (outward conductor + return conductor = twice the cable length) in m

A = conductor cross-section in mm^2

2. Calculate the total resistance of the battery cable. Use the following formula:

$$R_{\text{BatRes}} = R_{\text{cable 1}} + R_{\text{battery fuse}} + R_{\text{cable 2}}$$

R_{BatRes} = total resistance of the battery cable

$R_{\text{Cable 1}}$ = Calculated resistance of cable 1

$R_{\text{Cable 2}}$ = Calculated resistance of cable 2

$R_{\text{battery fuse}}$ = total resistance of the battery fuse (see manufacturer documentation)

3. Select **Battery > Battery**.
4. Select the parameter **Output resistance of battery connection** and set this to the resistance of the battery cable.

7.6.7 Setting the Control of the Battery Room Fan

QUALIFIED PERSON

The basic procedure for changing operating parameters is explained in another section (see Section 9.2 "Changing Operating Parameters", page 119).

Procedure:

1. Select **Device > Multifunction relay**.
2. Set the parameter **Temp lmt for multifunct. relay with batt comp fan** to the battery temperature at which the fan is to be switched on.
3. Ensure that the multifunction relay used for control is set to **Battery compartment fan** or **Battery fan in Multicluster** (see Section 7.10.2 "Setting the Functions of the Multifunction Relays", page 108).
4. Ensure that the battery room is sufficiently ventilated in the case of malfunctions – for example, on failure of the multifunction relay.

7.7 Energy management

7.7.1 Setting Load Shedding in a Multicluster System

The basic procedure for changing operating parameters is explained in another section (see Section 9.2 "Changing Operating Parameters", page 119).

Relevant for off-grid systems

The load contactor in the Multicluster-Box is a load-shedding contactor and is controlled depending on the state of charge of the batteries.

Significance of the SOC thresholds:

When the state of charge of a battery reaches the lower SOC threshold, the load contactor is opened. The state of charge of the battery of the main cluster and the states of charge of the batteries of the extension clusters are evaluated. The load contactor disconnects the loads from the stand-alone grid. When the state of charge of all batteries reaches the upper SOC threshold during recharging, the load contactor closes. The load-shedding contactor connects the loads to the stand-alone grid.

Procedure:

1. Select **Device > Load shedding 1**.
2. Set the parameter **Limit of battery state of charge for start** to the lower SOC threshold.
3. Set the parameter **Limit of battery state of charge for stop** to the upper SOC threshold. The upper SOC threshold must be at least 10 percentage points above the lower SOC threshold.
4. Select **Device > Load shedding 1 > Additional time range >**.

5. Set the parameter **Time load shedding 1** and the parameter **Start time additional time range load shedding 1** each to the same value, e.g. to **00:00:00**. This will switch the time-dependent load shedding off.
6. If the off-grid system is a multicluster system, ensure that the parameter of the multifunction relay is set to **Load shedding in Multicluster** (see Section 7.10.2 "Setting the Functions of the Multifunction Relays", page 108).

7.7.2 Setting One-Level Load Shedding

The basic procedure for changing operating parameters is explained in another section (see Section 9.2 "Changing Operating Parameters", page 119).

One multifunction relay controls the load-shedding contactor depending on the state of charge of the battery.

Significance of the SOC thresholds:

When the state of charge of the battery reaches the lower SOC threshold, the multifunction relay opens the connected load-shedding contactor. The load-shedding contactor disconnects the loads from the stand-alone grid. When the state of charge of the battery reaches the upper SOC threshold during recharging, the multifunction relay closes the connected load-shedding contactor. The load-shedding contactor connects the loads to the stand-alone grid.

Procedure:

1. Select **Device > Load shedding 1 > Additional time range**.
2. Set the parameter **Lmt value battery state of charge for start load shedding 1** to the lower SOC threshold.
3. Set the parameter **Lmt value battery state of charge for stop load shedding 1** to the upper SOC threshold. The upper SOC threshold must be at least 10 percentage points above the lower SOC threshold.
4. Set the parameter **Time load shedding 1** and the parameter **Start time additional time range load shedding 1** each to the same value, e.g. to **00:00:00**. This will switch the time-dependent load shedding off.
5. If the loads are only to be reconnected when the set SOC threshold is reached, ensure that the parameter of the multifunction relay has been set to **1-stage load shedding or 1st stage with 2-stage load shedding** (see Section 7.10.2 "Setting the Functions of the Multifunction Relays", page 108).
6. If the loads are to be supplied by an external energy source during recharging of the battery, perform the following steps:
 - Ensure that the parameter of the multifunction relay is set to **1-stage load shedding** (see Section 7.10.2 "Setting the Functions of the Multifunction Relays", page 108).
 - Ensure that the external energy source can supply the loads with sufficient power.
7. If the off-grid system is a multicluster system, ensure that the parameter of the multifunction relay is set to **Load shedding in Multicluster** (see Section 7.10.2 "Setting the Functions of the Multifunction Relays", page 108).

7.7.3 Setting Two-Level Load Shedding

The basic procedure for changing operating parameters is explained in another section (see Section 9.2 "Changing Operating Parameters", page 119).

Two multifunction relays control two load-shedding contactors depending on the state of charge of the battery.

Significance of the SOC thresholds:

Two lower and two upper SOC thresholds are available for each interval for controlling the load-shedding contactors. The load-shedding contactors disconnect the loads from the utility grid if the states of charge are as follows:

- When the state of charge of the battery reaches the first lower SOC threshold, the multifunction relay opens the connected load-shedding contactor for the first level of load shedding. The load-shedding contactor disconnects those loads from the utility grid that are to be disconnected for the first level.
- When the state of charge of the battery reaches the second lower SOC threshold, the multifunction relay opens the connected load-shedding contactor for the second level of load shedding. The load-shedding contactor disconnects the remaining loads from the utility grid.
- When the state of charge of the battery reaches the second upper SOC threshold during recharging, the multifunction relay closes the connected load-shedding contactor for the second level of load shedding. The load-shedding contactor connects those loads to the utility grid that were disconnected for the second level.
- When the state of charge of the battery reaches the first upper SOC threshold during recharging, the multifunction relay closes the connected load-shedding contactor for the first level of load shedding. The load-shedding contactor connects those loads, which were disconnected for the first level, to the utility grid. All loads are connected to the utility grid.

Procedure:

1. Setting the First Level of Load Shedding:

- Select **Device > Load shedding 1 > Additional time range**.
- Set the parameter **Lmt value battery state of charge for start load shedding 1** to the lower SOC threshold.
- Set the parameter **Lmt value battery state of charge for stop load shedding 1** to the upper SOC threshold.
- Set the parameter **Time load shedding 1** and the parameter **Start time additional time range load shedding 1** each to the same value, e.g. to **00:00:00**. This will switch the time-dependent load shedding off.
- Ensure that the parameter of the multifunction relay has been set to **1-stage load shedding or 1st stage with 2-stage load shedding** (see Section 7.10.2 "Setting the Functions of the Multifunction Relays", page 108).

2. Setting the second level of load shedding:

- Select **Device > Load shedding 2**.
- Set the parameter **Lmt value battery state of charge for start load shedding 2** to the lower SOC threshold.
- Set the parameter **Limit battery state of charge for stop load shedding 2 in add time range** to the upper SOC threshold.
- Select **Device > Load shedding 2 > Additional time range**.
- Set the parameter **Time load shedding 2** and the parameter **Start time additional time range load shedding 2** each to the same value, e.g. to **00:00:00**. This will switch the time-dependent load shedding off.
- Ensure that the parameter of the multifunction relay has been set to **1st stage with 2-stage load shedding** (see Section 7.10.2 "Setting the Functions of the Multifunction Relays", page 108).

7.7.4 Setting Time-Dependent One-Level Load Shedding

The basic procedure for changing operating parameters is explained in another section (see Section 9.2 "Changing Operating Parameters", page 119).

The time-dependent load shedding divides the day into two intervals (see Section 9.8.2 "Setting Time-Dependent Functions", page 123). You set the SOC thresholds that apply for each interval. For example, you can set that no loads are to be disconnected from the utility grid during the night where possible.

Significance of the SOC thresholds:

When the state of charge of the battery reaches the lower SOC threshold, the multifunction relay opens the connected load-shedding contactor. The load-shedding contactor disconnects the loads from the utility grid. When the state of charge of the battery reaches the upper SOC threshold during recharging, the multifunction relay closes the connected load-shedding contactor. The load-shedding contactor connects the loads to the utility grid.

Example: from 10:00 p.m. to 6:00 a.m., the load-shedding contactor is not to disconnect the loads from the utility grid where possible.

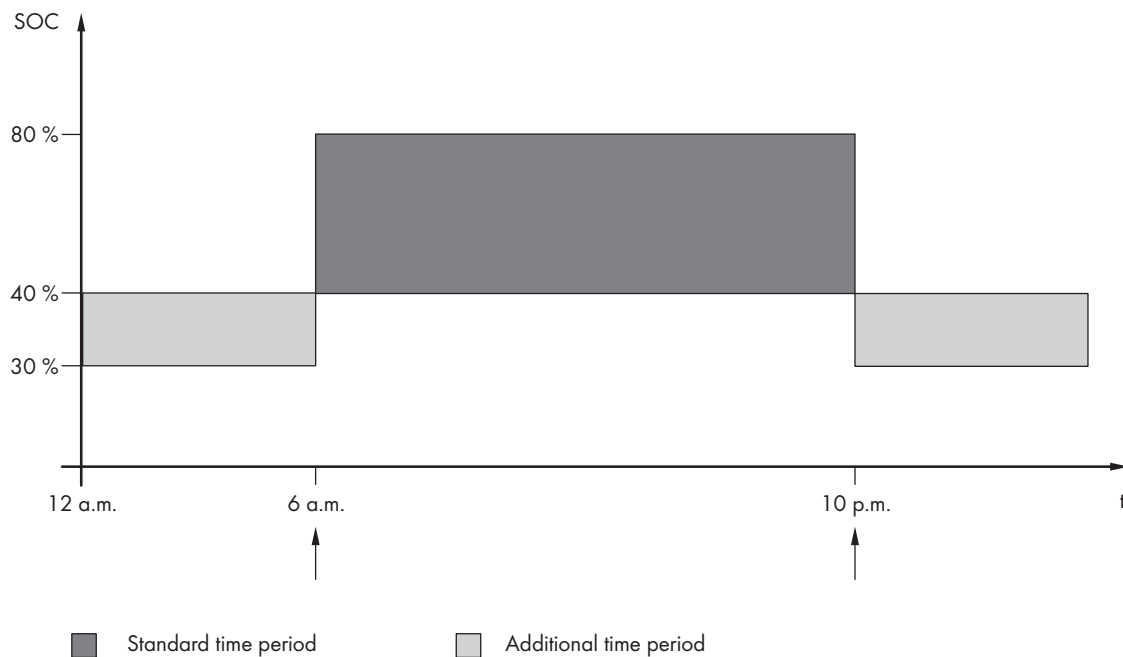

Figure 21: Profile of the SOC thresholds for controlling the load-shedding contactor and the start times for the intervals

The start time for the first interval is set to 6:00 a.m. The lower SOC threshold is set to 40% and the upper SOC threshold is set to 80% in this time interval.

The start time for the second interval is set to 10:00 p.m. The lower SOC threshold is set to 30% and the upper SOC threshold is set to 40% in this interval.

Procedure:

1. Select **Device > Load shedding 1 > Additional time range**.
2. Set the parameters for the standard time period:
 - Set the parameter **Time load shedding 1** to the start time for the standard time period.
 - Set the parameter **Lmt value battery state of charge for start load shedding 1** to the lower SOC threshold for the standard time period.
 - Set the parameter **Lmt value battery state of charge for stop load shedding 1** to the upper SOC threshold for the standard time period.
3. Set the parameters for the additional time period:
 - Set the parameter **Start time additional time range load shedding 1** to the start time for the additional time period.
 - Set the parameter **Limit battery state of charge for start load shedding 1 in add time range** to the lower SOC threshold for the additional time period.

- Set the parameter **Limit battery state of charge for stop load shedding 1 in add time range** to the upper SOC threshold for the additional time period.
4. Ensure that the parameter of the multifunction relay is set to **1-stage load shedding or 1st stage with 2-stage load shedding** (see Section 7.10.2 "Setting the Functions of the Multifunction Relays", page 108).

7.7.5 Setting Time-Dependent Two-Level Load Shedding

The basic procedure for changing operating parameters is explained in another section (see Section 9.2 "Changing Operating Parameters", page 119).

The time-dependent load shedding divides the day into two intervals (see Section 9.8.2 "Setting Time-Dependent Functions", page 123). You set the SOC thresholds that apply for each interval for two-level load shedding. For example, you can set that as far as possible no loads are to be disconnected from the utility grid during the day.

Significance of the SOC thresholds:

Two lower and two upper SOC thresholds are available for each interval for controlling the load-shedding contactors. The load-shedding contactors disconnect the loads from the utility grid if the states of charge are as follows:

- When the state of charge of the battery reaches the first lower SOC threshold, the multifunction relay opens the connected load-shedding contactor for the first level of load shedding. The load-shedding contactor disconnects those loads from the utility grid that are to be disconnected for the first level.
- When the state of charge of the battery reaches the second lower SOC threshold, the multifunction relay opens the connected load-shedding contactor for the second level of load shedding. The load-shedding contactor disconnects the remaining loads from the utility grid.
- When the state of charge of the battery reaches the second upper SOC threshold during recharging, the multifunction relay closes the connected load-shedding contactor for the second level of load shedding. The load-shedding contactor connects those loads to the utility grid that were disconnected for the second level.
- When the state of charge of the battery reaches the first upper SOC threshold during recharging, the multifunction relay closes the connected load-shedding contactor for the first level of load shedding. The load-shedding contactor connects those loads, which were disconnected for the first level, to the utility grid. All loads are connected to the utility grid.

Procedure:

1. Select **Device > Load shedding 1 > Additional time range**.
2. Set the parameter **Time load shedding 1** to the start time for the first interval.
3. Set the parameter **Start time additional time range load shedding 1** to the start time for the second interval.
4. Set the SOC threshold for the standard time period:
 - Select **Device > Load shedding 1**.
 - Set the parameter **Lmt value battery state of charge for start load shedding 1** to the lower SOC threshold for the first level of load shedding.
 - Set the parameter **Lmt value battery state of charge for stop load shedding 1** to the upper SOC threshold for the first level of load shedding.
 - Select **Device > Load shedding 2**.
 - Set the parameter **Lmt value battery state of charge for start load shedding 2** to the lower SOC threshold for the second level of load shedding.
 - Set the parameter **Limit battery state of charge for stop load shedding 2 in add time range** to the upper SOC threshold for the second level of load shedding.
5. Set the SOC threshold for the additional time period:
 - Select **Device > Load shedding 1**.

- Set the parameter **Limit battery state of charge for start load shedding 1 in add time range** to the lower SOC threshold for the first level of load shedding.
 - Set the parameter **Limit battery state of charge for stop load shedding 1 in add time range** to the upper SOC threshold for the first level of load shedding.
 - Select **Device > Load shedding 2**.
 - Set the parameter **Limit battery state of charge for start load shedding 2 in add time range** to the lower SOC threshold for the second level of load shedding.
 - Set the parameter **Limit battery state of charge for stop load shedding 2 in add time range** to the upper SOC threshold for the second level of load shedding.
6. Ensure that the multifunction relay used for controlling the first level of load shedding is set to **1-stage load shedding or 1st stage with 2-stage load shedding** (see Section 7.10.2 "Setting the Functions of the Multifunction Relays", page 108).
 7. Ensure that the multifunction relay used for controlling the second level of load shedding is set to **1st stage with 2-stage load shedding**.

Relevant for off-grid systems

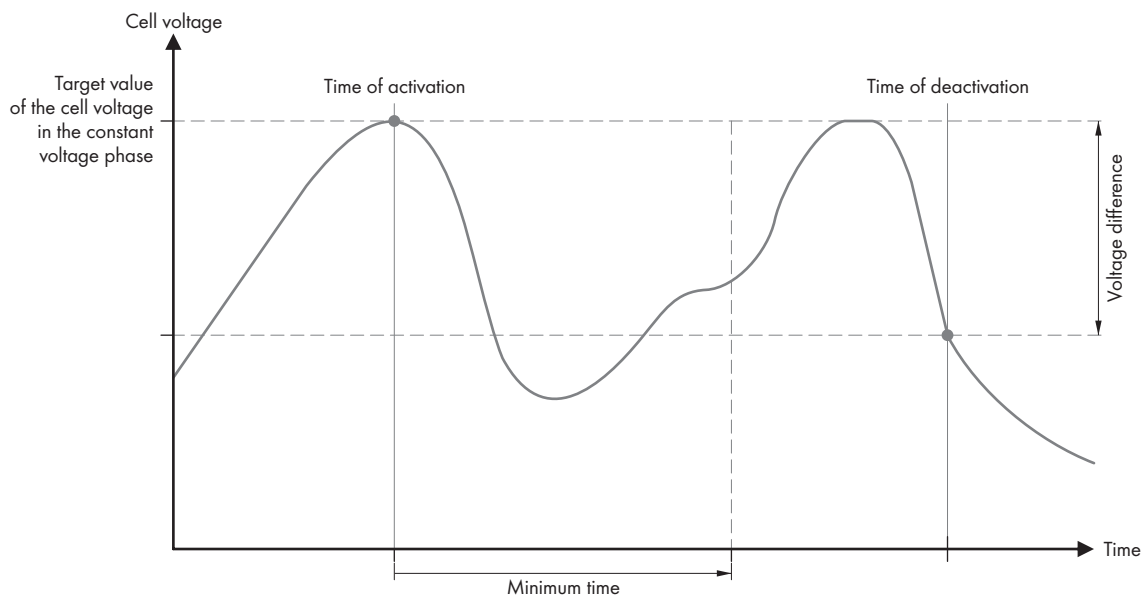



Figure 22: Switching-on time and switching-off time for utilization of excess energy during constant voltage phase

The Sunny Island controls the utilization of excess energy during the constant voltage phase depending on the cell voltage of the battery. During the constant voltage phase, the battery is charged with a constant charging voltage. When the setpoint of the cell voltage in the constant voltage phase is reached, the multifunction relay is activated. The multifunction relay remains in this position for the minimum time **241.07 ExtPwrDerMinTm**. If the cell voltage differs by more than **241.08 ExtPwrDerDltVtg** from the setpoint of the cell voltage, the multifunction relay is deactivated. The setpoint of the cell voltage depends on the charging process during the constant voltage phase.

| Charging Process | Parameter | Default value |
|---------------------|---|---------------|
| Boost charge | Battery > Charge > Cell charge nominal voltage for boost charge | 2.40 V |
| Full charge | Battery > Charge > Cell charge nominal voltage for full charging | 2.45 V |
| Equalization charge | Battery > Charge > Cell charge nominal voltage for equalization charge | 2.45 V |

The basic procedure for changing operating parameters is explained in another section (see Section 9.2 "Changing Operating Parameters", page 119).

Procedure:

1. Set the parameter **241.07 ExtPwrDerMinTm** to the minimum time that the multifunction relay remains activated.
2. Set the parameter **241.08 ExtPwrDerDltVtg** to the voltage difference relative to the setpoint of the cell voltage during the constant voltage phase.
3.  **Recording of the measured values of the cell voltage reacts to changes with time-lag**
The Sunny Island calculates the cell voltage from the measured battery voltage. The Sunny Island calculates an average from the measured values of the battery voltage. As a result of the calculation of an average, the cell voltage that is recorded reacts to changes with a time-lag.
4. Ensure that the multifunction relay used for control is set to **Control of add. loads** (see Section 7.10.2 "Setting the Functions of the Multifunction Relays", page 108).

7.8 Generator Management

7.8.1 Configuration of the Thresholds for Generator Connection

7.8.1.1 Changing the Current Thresholds for the Generator

QUALIFIED PERSON

Relevant for off-grid systems

The basic procedure for changing operating parameters is explained in another section (see Section 9.2 "Changing Operating Parameters", page 119).

Significance of the current limits:

The generator management limits the consumption of generator current to the maximum set value.

In three-phase systems, the generator current is limited for each line conductor individually. The set value applies to each line conductor.

For Sunny Island inverters that are operated in parallel, the generator management only limits the total generator current. The generator current may be unequally distributed to the Sunny Island inverters. If a Sunny Island fails, for example, more current flows through the remaining Sunny Island inverters.

Enhanced generator management:

If the set generator current is not sufficient for supplying the loads, the generator management requests additional current from the battery. The system then supplies the loads with the generator current and the battery current.

Procedure:

1. Select **Generator > Generator**.
2. Set the parameter **Rated generator current** to the desired value.
Tip: A suitable value for the **Rated generator current** is 80% of the maximum generator current per line conductor.

7.8.1.2 Changing the Voltage Thresholds for the Generator

QUALIFIED PERSON

Relevant for off-grid systems

The voltage thresholds determine the range within which the generator voltage is allowed to fluctuate. When the Sunny Island switches to the generator, the stand-alone grid will also fluctuate within this range.

A breach of the set voltage thresholds leads to disconnection of the line conductor from the stand-alone grid or the generator not being switched on.

The basic procedure for changing operating parameters is explained in another section (see Section 9.2 "Changing Operating Parameters", page 119).

Procedure:

1. Select **Generator > Generator > Voltage monitoring**.
2. Set the parameter **Voltage monit. gener. lower minimum threshold** to the minimum generator voltage.
3. Set the parameter **Voltage monit. gener. upper maximum threshold** to the maximum generator voltage.

7.8.1.3 Changing the Frequency Thresholds of the Generator Voltage

QUALIFIED PERSON

Relevant for off-grid systems

The frequency thresholds determine the range within which the frequency of the generator voltage is allowed to fluctuate. When the Sunny Island switches to the generator, the stand-alone grid will also fluctuate within this range.

A breach of the set frequency thresholds leads to disconnection of the line conductor from the stand-alone grid or to the generator not being switched on.

The basic procedure for changing operating parameters is explained in another section (see Section 9.2 "Changing Operating Parameters", page 119).

Procedure:

1. Select **Generator > Generator**.
2. Set the parameter **Generator nominal frequency** to the rated frequency of the generator voltage.
3. Select **Generator > Generator > Frequency monitoring**.
4. Set the parameter **Frequency monit. generator lower minimum threshold** to the minimum frequency of the generator voltage.
5. Set the parameter **Frequency monit. generator without max. threshold** to the maximum frequency of the generator voltage.

7.8.1.4 Changing the Permitted Reverse Power in the Generator

QUALIFIED PERSON

Relevant for off-grid systems

If the reverse power for the set time is exceeded, all Sunny Island inverters disconnect the generator from the stand-alone grid and block the connection of the generator to the stand-alone grid for the minimum stop time.

NOTICE

Generator damage

In the event of reverse power, the AC sources in the stand-alone grid drive the generator. The generator can be damaged as a result.

- Observe the manufacturer's information on reverse power protection of the generator.
- Set the generator reverse power and permitted time for reverse power according to the manufacturer's specifications.

The basic procedure for changing operating parameters is explained in another section (see Section 9.2 "Changing Operating Parameters", page 119).

Procedure:

1. Select **Generator > Generator > Power monitoring**.
2. Set the parameter **Voltage monitoring generator maximum reverse power** to the active power of the generator reverse power.
3. Set the parameter **Volt. monit. gener. max. reverse power trip. time** to the time of the generator reverse power.

7.8.1.5 Configuring the Current Limit for the Generator Depending on the Frequency

⚠ QUALIFIED PERSON



Relevant for off-grid systems

The higher the generator current, the higher the torque for the generator. With unregulated generators, the speed of rotation decreases with increasing torque. If the speed of rotation decreases, the frequency of the generator voltage is reduced.

If the frequency of the generator voltage falls below the rated frequency, the generator management can place additional limits on the generator current. The lower the frequency, the more the generator current is limited by the generator management. This setting is useful if the generator is supplying other loads parallel to the Sunny Island. This setting allows the maximum load to be placed on the generator without overloading it.

The basic procedure for changing operating parameters is explained in another section (see Section 9.2 "Changing Operating Parameters", page 119).

Requirement:

- The generator must not be an inverter generator. The output frequency of the inverter generator is fixed.

Procedure:

1. Select **Generator > Generator**.
2. Set the parameter **Rated generator current** to the desired value.
Tip: A suitable value for the parameter **Rated generator current** is 80% of the maximum generator current per line conductor.
3. Select **Generator > Operation**.
4. Set the parameter **Limitation type of generator current** to **Frequency-dependent current limitation**. This will activate the frequency-dependent current limiting.

7.8.2 Changing the Type of the Generator Interface

QUALIFIED PERSON

Relevant for off-grid systems

If you have installed a generator in the system, the type of generator interface determines how the generator is controlled.

The basic procedure for changing operating parameters is explained in another section (see Section 9.2 "Changing Operating Parameters", page 119).

Procedure:

1. Select **Generator > Generator**.
2. If the generator has an autostart function, set the parameter **Generator request** to **Automatic**.
3. If the generator does not have an autostart function, set the parameter **Generator request** to **Manual control**.

7.8.3 Configuring Generator Run Times

7.8.3.1 Changing the Warm-Up Time for the Generator

Relevant for off-grid systems

The basic procedure for changing operating parameters is explained in another section (see Section 9.2 "Changing Operating Parameters", page 119).

Relation between warm-up time and termination of generator start:

The generator management measures the time between the generator start and the beginning of the warm-up time. If a maximum time is exceeded, the generator management system terminates the generator start. The maximum time to start termination is double the warm-up time plus an additional two minutes.

With some generator types, the generator only switches the voltage to the output of the generator after the internal warm-up time has expired. During this time, the generator management is unable to recognize a valid generator voltage. If the warm-up time is set too low, the generator management terminates the generator start before the internal warm-up time has expired.

Procedure:

1. Select **Generator > Operation**.
2. Set the parameter **Warm-up time of generator** in accordance with the generator properties.

| Generator properties | | Setting Parameters |
|-------------------------------|-------------------------------|--|
| Without internal warm-up time | | <ul style="list-style-type: none"> • Set the desired warm-up time. |
| With internal warm-up time | Autostart compatible | <ul style="list-style-type: none"> • Set the warm-up time to be at least half the internal warm-up time of the generator. |
| | Without an autostart function | |

- The generator start is not terminated prematurely.

7.8.3.2 Changing the Minimum Run Time for the Generator

Relevant for off-grid systems

The basic procedure for changing operating parameters is explained in another section (see Section 9.2 "Changing Operating Parameters", page 119).

1. Select **Generator > Operation**.
2. Set the parameter **Average operating time of generator** to the desired value.

7.8.3.3 Changing the Power-Down Time for the Generator

 **Relevant for off-grid systems**

Internal shut-off delay of the generator

Generators may have an internal shut-off delay which is activated only once the generator request has been removed. Note that this internal shut-off delay increases the actual power-down time.

The basic procedure for changing operating parameters is explained in another section (see Section 9.2 "Changing Operating Parameters", page 119).

Procedure:

1. Select **Generator > Operation**.
2. Set the parameter **Cooling down time of generator** to the desired value.

7.8.3.4 Changing the Minimum Stop Time for the Generator

 **Relevant for off-grid systems**

The basic procedure for changing operating parameters is explained in another section (see Section 9.2 "Changing Operating Parameters", page 119).

Procedure:

1. Select **Generator > Operation**.
2. Set the parameter **Average idle period of generator** to the desired value.

7.8.4 Configuring the Generator Request

7.8.4.1 Changing the Automatic Generator Operation

 **QUALIFIED PERSON**

 **Relevant for off-grid systems**

In automatic generator operation, the generator management specifies when and for how long the generator runs, depending on the configuration.

The basic procedure for changing operating parameters is explained in another section (see Section 9.2 "Changing Operating Parameters", page 119).

Procedure:

1. Select **Generator > Generator**.
2. To deactivate automatic generator mode, set the parameter **Automatic generator start** to **Disable**.
3. To activate automatic generator mode, set the parameter **Automatic generator start** to **Enable**.

7.8.4.2 Changing a State-Of-Charge-Dependent Generator Request

 **QUALIFIED PERSON**

 **Relevant for off-grid systems**

If the battery reaches the lower SOC threshold, the generator management requests the generator. If the battery reaches the upper SOC threshold during recharging, the generator management resets this generator request.

The basic procedure for changing operating parameters is explained in another section (see Section 9.2 "Changing Operating Parameters", page 119).

Procedure:

1. Select **Generator > Generator queries state of charge**.
2. Set the parameter **Generator startup battery state of charge limit** to the lower SOC threshold.
3. Set the parameter **Generator shutdown battery state of charge limit** to the upper SOC threshold.
4. Select **Generator > Generator queries state of charge > Additional time range**.
5. Set the parameter **Start time range for generator request** and **Start time range for generator request** each to the same value, e.g., to **00:00:00**. This deactivates the time-dependent generator request.

7.8.4.3 Setting a Time-Dependent Generator Request

QUALIFIED PERSON

Relevant for off-grid systems

The basic procedure for changing operating parameters is explained in another section (see Section 9.2 "Changing Operating Parameters", page 119).

The time-dependent generator request divides the day into two intervals. For each interval, you set which conditions there are for the generator request (see Section 9.8.2 "Setting Time-Dependent Functions", page 123). In this way, you can, for example, set the generator not to start at night. This ensures that the noise pollution produced by the generator takes place during the day whenever possible. Both intervals each have a lower and an upper SOC threshold. If the battery reaches the lower SOC threshold, the generator management requests the generator. When the battery reaches the upper SOC threshold during recharging, generator management resets this generator request. The following settings are possible for the SOC thresholds:

- The lower SOC threshold is lower than the upper SOC threshold.
The generator is requested during this interval depending on the state of charge.
- The lower SOC threshold is higher than or equal to the upper SOC threshold.
The generator is not started depending on the state of charge. In this interval, the other settings for the generator request, e.g. the time-dependent generator request, apply.

Example: from 10:00 p.m. to 6:00 a.m., the generator is not to start where possible.

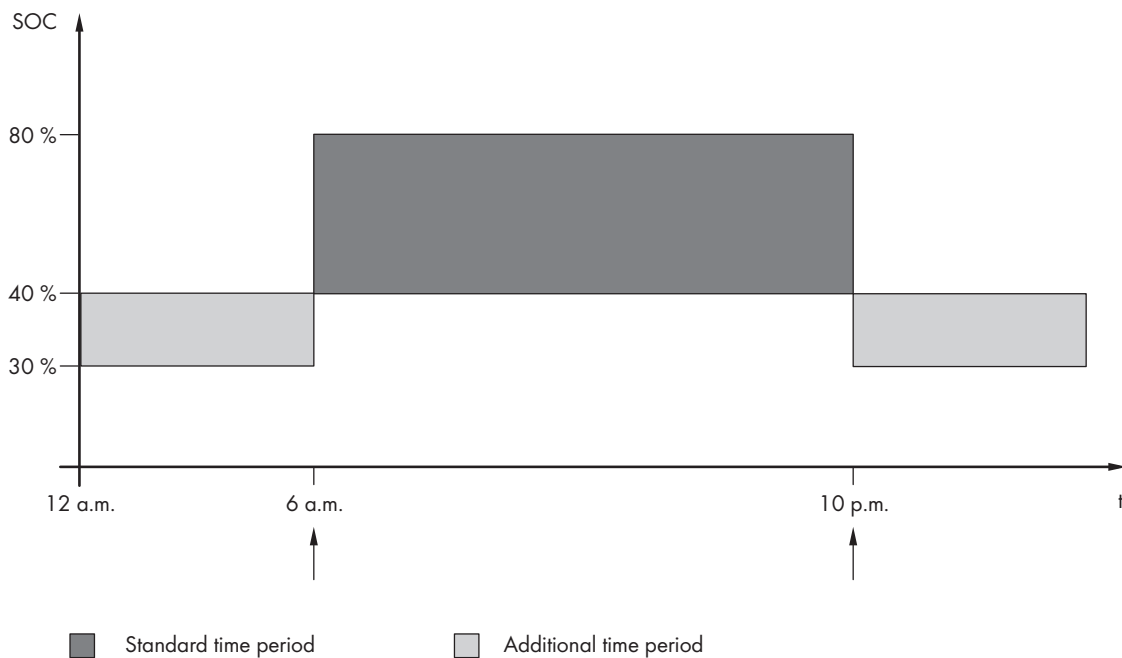

Figure 23: Profile of the SOC and the times for generator requests

For the standard time period, the start time is set to 6:00 a.m. and the end time to 10:00 p.m. The lower SOC threshold is set to 40% and the upper SOC threshold is set to 80% in this time period.

For the additional time period, the start time is set to 10:00 p.m. and the end time to 6:00 a.m. The lower SOC threshold is set to 30% SOC and the upper SOC threshold is set to 40% SOC in this time period.

Procedure:

1. Set the start times for the standard time period and the additional time period:
 - Select **Generator > Generator queries state of charge > Additional time range**.
 - Set the parameter **Start time range for generator request** to the start time for the standard time period.
 - Set the parameter **Start time range for generator request** to the start time for the additional time period.
2. Set the switch-on limits (lower SOC thresholds) for the standard time period and the additional time period:
 - Select **Generator > Generator queries state of charge > Additional time range > Switch-on limit in time range**.
 - Set the parameter **Generator startup battery state of charge limit** to the lower SOC threshold during the standard time period.
 - Set the parameter **Limit battery state of charge generator start in add time range** to the lower SOC threshold during the additional time period.
3. Set the switch-off limits (upper SOC thresholds) for the standard time period and the additional time period:
 - Select **Generator > Generator queries state of charge > Switch-off limit in time range**.
 - Set the parameter **Generator shutdown battery state of charge limit** to the upper SOC threshold during the standard time period.
 - Set the parameter **Limit battery state of charge generator stop in add time range** to the upper SOC threshold during the additional time period.

7.8.4.4 Configuring the Load-Dependent Generator Request

QUALIFIED PERSON

Relevant for off-grid systems

The basic procedure for changing operating parameters is explained in another section (see Section 9.2 "Changing Operating Parameters", page 119).

Significance of the load-dependent generator request:

If you activate the load-dependent generator request, the Sunny Island requests the generator in the event of a high load. This prevents the battery from deep electric discharging and cycling and extends its service life. The performance of the off-grid system for supplying loads increases to the sum of the generator power and the power of the Sunny Island inverter. This improves the system stability. The load is the average output power of the Sunny Island inverter.

Loads in a three-phase system:

The generator management considers the total load of all phases. It does not monitor single phases in three-phase systems. If the switch-on power limit is exceeded, the generator management requests the generator.

Time-based procedure of the load-dependent generator request:

If the switch-on power limit is reached, the generator management requests the generator. If the load then drops to the switch-off power limit, the generator management resets the generator request after the minimum run time. The generator management does not record the load as an instantaneous value. The generator management calculates the load across the averaging time. The longer the averaging time set, the less the generator management reacts to load peaks (parameter: **Generator > Time-controlled generator operation > Average time for generator request via power**).

Generator run times:

The warm-up, minimum and power-down times are adhered to after the generator start. The power of the generator is not immediately available in the stand-alone grid. Each start also means that the generator runs for at least the warm-up time, minimum run time and power-down time.

Procedure:

1. Select **Generator > Generator request via power**.
2. Set the parameter **Generator request via power on** to **Enable**. This will activate the load-dependent generator request.
3. Set the parameter **Generator startup load limit** to the switch-on power limit.
4. Set the parameter **Generator shutdown load limit** to the switch-off power limit.
5. Select **Generator > Time-controlled generator operation**.
6. Set the parameter **Average time for generator request via power** to the averaging time with which the generator management calculates the average power.

7.8.4.5 Time-Controlled Generator Requesting

QUALIFIED PERSON

Relevant for off-grid systems

If the generator is requested dependent on time, it is requested on certain days for a set duration (see Section 9.8.3 "Setting Time-Controlled Functions", page 123).

The basic procedure for changing operating parameters is explained in another section (see Section 9.2 "Changing Operating Parameters", page 119).

Procedure:

1. Select **Generator > Time-controlled generator operation**.
2. Set the parameter **Time-controlled generator operation** to **Enable**.
3. Set the parameter **Start time for time-controlled generator op.** to the desired start time of the generator with date and time.
4. Set the parameter **Operating time for time-controlled generator op.** to the desired operating time.
5. Set the parameter **Repeat cycle of time-controlled generator op.** to the desired repetition cycle:

| Value | Explanation |
|--------|---|
| Once | Single generator request on the start date |
| Daily | Daily generator request starting on the start date |
| Weekly | Weekly generator request starting on the start date The start date determines the weekday. |

7.8.4.6 Changing the Generator Request via the Charging Process of the Battery

⚠ QUALIFIED PERSON



Relevant for off-grid systems

The basic procedure for changing operating parameters is explained in another section (see Section 9.2 "Changing Operating Parameters", page 119).

Procedure:

1. Select **Generator > Generator request via charge type**.
2. Set the parameter **Generator request with set charge type** to the desired generator request:

| Value | Explanation |
|------------------------------|---|
| Equalization charge | Generator request during equalization charge |
| Full charge | Generator request during full charge |
| Full and equalization charge | Generator request during equalization and full charge |
| Off | Deactivation of the generator request via the charging process of the battery |

7.8.4.7 Setting an External Generator Request

⚠ QUALIFIED PERSON



Relevant for off-grid systems

An external control signal can transmit a generator request to the generator management.

The basic procedure for changing operating parameters is explained in another section (see Section 9.2 "Changing Operating Parameters", page 119).

Procedure:

1. Select **Generator > Generator request via digital input**.
2. In order to activate the external generator request, set the parameter **Reaction to digital input of generator request** to **Enable**.
3. In order to deactivate the external generator request, set the parameter **Reaction to digital input of generator request** to **Disable**.

7.8.5 Configuring the Procedure in the Event of a Generator False Start

QUALIFIED PERSON

Relevant for off-grid systems

Operating procedure if a generator false start is detected:

If the Sunny Island detects a generator false start (e.g., voltage too high), the Sunny Island does not connect the stand-alone grid to the generator. If there is another request for the generator after the minimum stop time, the Sunny Island attempts to start the generator. If the Sunny Island detects a false start on numerous occasions and the number of failed attempts exceeds the maximum value, the Sunny Island switches into error status. The Sunny Island attempts to restart the generator upon expiry of the **Idle period after generator fault**.

Single cluster systems:

The generator management classifies a line conductor fault on the master as a generator failure. All Sunny Island inverters disconnect the stand-alone grid from the generator. The generator management treats a fault on the slave line conductor as a line conductor fault. The slave disconnects only the affected line conductor from the stand-alone grid. The slave switches the stand-alone grid to the generator again if the faulty line conductor is in the valid range.

Procedure:

The basic procedure for changing operating parameters is explained in another section (see Section 9.2 "Changing Operating Parameters", page 119).

1. Select **Generator > Generator**.
2. Select the parameter **Automatic generator start**.
3. Activate the automatic generator start and set the desired number of start attempts.
4. In order to change the idle time of the generator after the maximum number of start attempts has been exceeded, select **Generator > Operation** and set the parameter **Idle period after generator fault** to the desired stop time.

7.9 Off-Grid System

7.9.1 Commissioning the Battery Current Sensor in Off-Grid Systems

QUALIFIED PERSON

Relevant for off-grid systems

To operate the battery current sensor, you must set the type of the battery current sensor and start the adjustments of the battery current sensor.

The Sunny Island distinguishes between battery current sensors of the types 50 mV and 60 mV. The types reflect the amplification factor of the battery current sensor. The amplification factors are given in amperes per 50 mV or in amperes per 60 mV, e.g., 400 A/60 mV.

The basic procedure for changing operating parameters is explained in another section (see Section 9.2 "Changing Operating Parameters", page 119).

Procedure:

1. Switch off the Sunny Island and open the battery fuse load-break switch quickly.

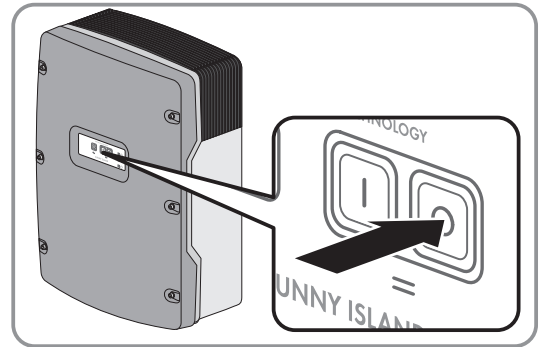

2. Short-circuit the measuring cable at the battery current sensor. To do so, Connect the **BatCur-** and **BatCur+** insulated measuring conductors to the connection for **BatCur+**.

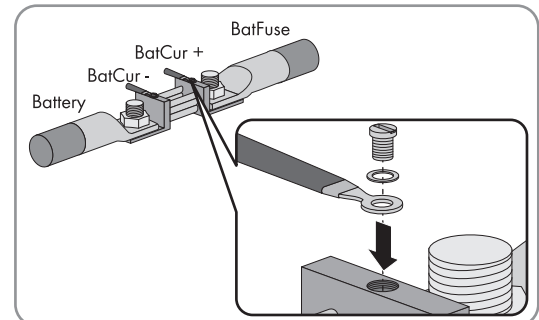

3. Close the battery fuse load-break switch quickly and switch on the Sunny Island.

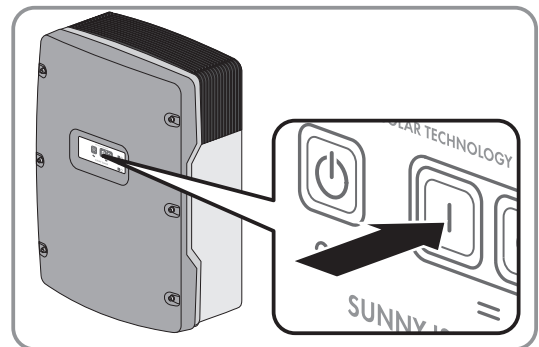

4. Set the parameter **Current sensor type (60mV, 50mV)** to the type and amplification factor of the battery current sensor used.
5. Select the parameter **Autocalibration of the external battery current sensor** and set to **On**.
 - The Sunny Island starts the adjustment.
6. After 10 seconds, select the parameter **Battery > Battery > Current > Battery current** and read off the value.
 - The parameter value is between 0 A and 1 A.
 - The parameter value is not between 0 A and 1 A.
 - The measuring cables are not correctly connected or not short-circuited.
 - Check whether the measuring cables are correctly connected and whether they are short-circuited.
 - Repeat steps 8 and 9.
7. Switch off the Sunny Island and open the battery fuse load-break switch quickly.

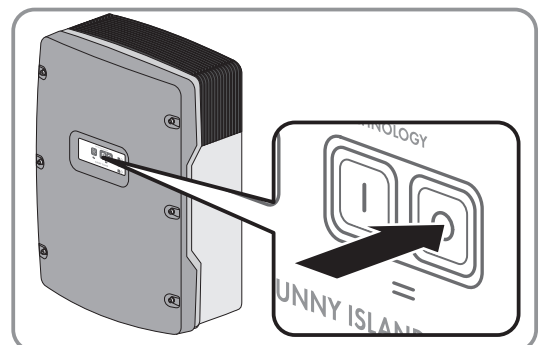

8. Connect the **BatCur+** insulated measuring conductor on the side for connecting the battery fuse.

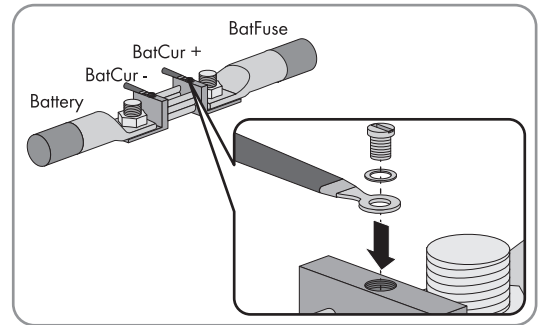

9. Connect the **BatCur-** insulated measuring conductor on the side for connecting the battery.

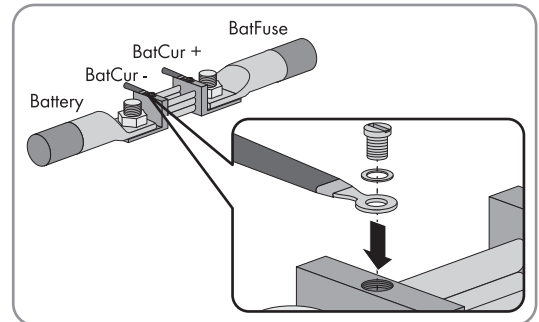

10. Close the battery fuse load-break switch quickly and switch on the inverter.

7.9.2 Changing the Automatic Frequency Synchronization in Off-Grid Systems

⚠ QUALIFIED PERSON



Relevant for off-grid systems

Automatic frequency synchronization enables the use of clocks which use the power frequency as a timer. The power frequency determines the accuracy of the clock. For power frequencies with constant frequency deviations from the rated frequency, the time indications will become more and more inaccurate. Continuous frequency deviations occur in off-grid systems with generators, for example. If the automatic frequency synchronization is activated, the Sunny Island regulates the frequency deviations over time. As a result, the accuracy of clocks that use the power frequency as timers is increased.

The basic procedure for changing operating parameters is explained in another section (see Section 9.2 "Changing Operating Parameters", page 119).

Procedure:

1. Select **AC Side > Operation**.
2. To deactivate automatic frequency synchronization, set the parameter **Automatic frequency control** to **Disable**.
3. To activate automatic frequency synchronization, set the parameter **Automatic frequency control** to **Enable**.

7.10 Multifunction Relay

7.10.1 Setting the Time Control

The time control controls up to two multifunction relays according to the set times.

The basic procedure for changing operating parameters is explained in another section (see Section 9.2 "Changing Operating Parameters", page 119).

Procedure:

1. Select **Device > Multifunction relay > Timer**.
2. Select the parameter **Start date of relay control for timer** and set the desired start times.

- Start time for timer 1, date
 - Start time for timer 1, time
 - Start time for timer 2, date
 - Start time for timer 2, time
3. Select the parameter **Duration for which multifunction relay is activated for timer** and set the desired running times:
- Running time for timer 1
 - Running time for timer 2
4. Select the parameter **Repeat cycle time of relay control for timer** and set the desired cycle times:
- Repetition cycle time for timer 1
 - Repetition cycle time for timer 2

7.10.2 Setting the Functions of the Multifunction Relays

⚠ QUALIFIED PERSON

The multifunction relays of the master are preset in an SMA Flexible Storage System and cannot be changed.

In multicluster systems with Multicluster-Box 12 (MC-BOX-12.3-20), multifunction relays 1 and 2 in the master of the main cluster and multifunction relay 1 in slave 1 of the main cluster are set permanently.

Note the function of the multifunction relays in the following table during the electrical connection (see Section 6.5 "Connecting the Components", page 33).

Table for configuring the operating modes of the multifunction relay (for your own notes):

| Parameter | Multifunction relay | Value | Function/output |
|--|--|-------|-----------------|
| Operating mode of the multifunction relay | Relay 1 of Sunny Island inverter/master | | |
| | Relay 2 of Sunny Island inverter/master | | |
| Slave 1: Operating mode of multifunction relay | Relay 1 of Slave 1 | | |
| | Relay 2 of Slave 1 | | |
| Slave 2: Operating mode of multifunction relay | Relay 1 of Slave 2 | | |
| | Relay 2 of Slave 2 | | |

Procedure:

The basic procedure for changing operating parameters is explained in another section (see Section 9.2 "Changing Operating Parameters", page 119).

1. Select the display group **Device > Multifunction relay > Operating mode**.
2. Set the parameter for the multifunction relay functions as shown in the table above.

7.11 Complete Commissioning.

QUALIFIED PERSON

Load shedding in the first two operating hours

The state of charge (SOC) recorded by battery management and the available battery capacity (SOH) will deviate strongly from the actual values of SOC and SOH for a newly connected battery. During operation, the values recorded by battery management will gradually approach the real values. In the first two operating hours with the new battery, these deviations can lead to load shedding and corresponding messages. These messages will be displayed on the Sunny Island user interface (see Section 15.2 "Event Messages", page 145).

Procedure:

1. Make sure that the wiring is correct (see Section 6.7, page 68).
2. Ensure that all system-specific preparations for commissioning have been implemented correctly (see system description Sunny Island system used).
3. Connect or close the circuit breakers and fuse switch-disconnectors for energy sources.
4. With off-grid systems only, disconnect or open all loads, the circuit breakers of the loads and the fuse switch-disconnector. As a result, only the energy sources are connected to the Sunny Island.
5. Start the Sunny Island system (see Section 10.2, page 124).
6. With off-grid systems only, when full charge is complete, switch on all circuit breakers and load-break switches.
Tip: The state of charge of the battery is displayed on the Sunny Remote Control in standard mode.
7. In order to receive service assignments for the Sunny Island system, all system data must be recorded in the information sheet for Sunny Island systems and made available to Service (for information sheet see www.SMA-Solar.com).

8 Using the Inverter User Interface

8.1 Establishing a connection to the user interface

8.1.1 Establishing a direct connection via WLAN

Requirements:

- The inverter must be commissioned.
- A computer, tablet PC or smartphone with WLAN interface must be available.
- In the case of a computer connection, one of the following web browsers must be installed: Firefox (as of version 25), Internet Explorer (as of version 10), Safari (as of version 7), Opera (as of version 17) or Google Chrome (as of version 30).
- In the case of a tablet PC or smartphone connection, one of the following web browsers must be installed: Firefox (as of version 25), Safari (as of version iOS 7) or Google Chrome (as of version 29).
- The personal SMA Grid Guard code of the Installer must be available for the changing of grid-relevant settings after completion of the first ten operating hours (see "Application for SMA Grid Guard Code" at www.SMA-Solar.com).

i Inverter SSID and IP address and necessary passwords

- Inverter SSID in WLAN: SMA[serial number] (e.g. SMA2130019815)
- Standard WLAN password (usable for initial configuration to completion of the first ten operating hours): SMA 12345
- Device-specific WLAN password (usable for initial configuration to completion of the first ten operating hours): see WPA2-PSK on the type label of the inverter or on the back of the manual included in the delivery
- Standard IP inverter address for a direct connection via WLAN outside of a local network: 192.168.12.3

i Importing and exporting files with end devices having an iOS operating system is not possible.

For technical reasons, importing and exporting files (e.g. importing an inverter configuration, saving the current inverter configuration or exporting events) is not possible with mobile end devices having an iOS operating system.

- Use an end device that does not have an iOS operating system for importing and exporting files.

The procedure can be different depending on the terminal devices used (e.g. computer, tablet PC or smartphone). If the procedure described does not apply to your device, establish the direct connection via WLAN as described in the manual of your device.

Procedure:

1. If your computer, tablet PC or smartphone has a WPS function:
 - Activate the WPS function on the inverter. To do this, tap on the enclosure lid of the inverter twice.
 - A signal sounds for one second followed by a one second break. After this break the signal sounds again for one second.
 - Activate the WPS on your device.
 - The connection with your device will be established automatically. It can take up to 20 seconds for this connection to be established.
2. If your computer, tablet PC or smartphone does not have a WPS function:
 - Search for WLAN networks with your device.
 - Select the SSID of the inverter **SMA[serial number]** in the list with the found WLAN networks.

- Enter the inverter WLAN password. Within the first 10 operating hours, you must use the standard WLAN password **SMA12345**. After the first 10 operating hours, you must use the device-specific WLAN password (WPA2-PSK) of the inverter. The WLAN password (WPA2-PSK) is printed on the type label.
3. Enter the IP address **192.168.12.3** or, if your device supports mDNS services, **SMA[serial number].local** in the address line of the web browser and press the enter key.
 4. **i** **Web browser signals a security vulnerability**

After the IP address has been confirmed by pressing the enter key, a message might appear indicating that the connection to the user interface of the inverter is not secure. SMA Solar Technology AG guarantees that calling up the user interface is secure.

 - Continue loading the user interface.

The login page of the user interface opens.

8.1.2 Establishing a Direct Connection via Ethernet

Requirements:

- The inverter must be commissioned.
- A computer with an Ethernet interface must be available.
- The inverter must be connected directly to a computer.
- One of the following web browsers must be installed: Firefox (as of version 25), Internet Explorer (as of version 10), Safari (as of version 7), Opera (as of version 17) or Google Chrome (as of version 30).
- The personal SMA Grid Guard code of the Installer must be available for the changing of grid-relevant settings after completion of the first ten operating hours (see certificate "Application for SMA Grid Guard Code" at www.SMA-Solar.com).

i IP address of the inverter

- Standard inverter IP address for direct connection via Ethernet: 169.254.12.3

Procedure:

1. Open the web browser of your device, enter the IP address **169.254.12.3** in the address line and press the enter key.
2. **i** **Web browser signals a security vulnerability**

After the IP address has been confirmed by pressing the enter key, a message might appear indicating that the connection to the user interface of the inverter is not secure. SMA Solar Technology AG guarantees that calling up the user interface is secure.

 - Continue loading the user interface.

The login page of the user interface opens.

8.1.3 Establishing a Connection via Ethernet in the local network

i New IP address for connecting with a local network

If the inverter is connected to a local network via a network cable (e.g. via a router), the inverter will receive a new IP address. Depending on the type of configuration, the new IP address will be assigned automatically by the DHCP server (router) or manually by you. Upon completion of the configuration, the inverter is only reachable via this new IP address or the alternative addresses.

Access addresses of the inverter:

- Generally applicable access address, e.g. for android products: IP address manually assigned or assigned by the DHCP server (router) (identification via SMA Connection Assist, network scanner software or router manual).
- Alternative access address for Apple products: SMA[serial number].local (e.g. SMA2130019815.local)
- Alternative access address for certain Windows products: SMA[serial number] (e.g. SMA2130019815)

Requirements:

- The inverter must be connected to the local network via a network cable (e.g. via a router).
- The inverter must be integrated in the local network.
- A computer, tablet PC or smartphone must be available and the computer, tablet PC or smartphone must be connected with the network to which the inverter is also connected.
- In the case of a computer connection, one of the following web browsers must be installed: Firefox (as of version 25), Internet Explorer (as of version 10), Safari (as of version 7), Opera (as of version 17) or Google Chrome (as of version 30).
- In the case of a tablet PC or smartphone connection, one of the following web browsers must be installed: Firefox (as of version 25), Safari (as of version iOS 7) or Google Chrome (as of version 29).
- The personal SMA Grid Guard code of the Installer must be available for the changing of grid-relevant settings after completion of the first ten feed-in hours (see certificate "Application for SMA Grid Guard Code" at www.SMA-Solar.com).

Procedure:

1. Open the web browser of your device, enter the IP address of the inverter in the address line of the web browser and press the enter key.

2. **i** Web browser signals a security vulnerability

After the IP address has been confirmed by pressing the enter key, a message might appear indicating that the connection to the user interface of the inverter is not secure. SMA Solar Technology AG guarantees that calling up the user interface is secure.

- Continue loading the user interface.

- The login page of the user interface opens.

8.2 Logging In and Out of the User Interface

After a connection to the user interface of the inverter has been established, the login page opens. Log onto the user interface as described below.

i Usage of cookies

For the correct display of the user interface, cookies are required. The cookies are used for convenience only. By using this user interface you agree to the placement of cookies.

Log in as installer or user for the first time

i Password for PV systems that are registered in a communication product

The password for the user group **Installer** is also the system password. If you assign a password for the user group **Installer** via the user interface of the inverter, the password must match the PV system password. If the new password for logging onto the user interface does not match the system password in the communication product, the inverter cannot be reached by the communication product.

- A uniform password is assigned for all Speedwire devices in the PV system.

Procedure:

1. In the drop-down list **Language**, select the desired language.
 2. In the **User group** drop-down list, select the entry **Installer** or **User**.
 3. In the **New password** field, enter a new password for the selected user group.
 4. In the **Repeat password** field, enter the new password again.
 5. Select **Login**.
- The installation assistant will open.

Log in as the User or Installer

1. In the drop-down list **Language**, select the desired language.
 2. In the **User group** drop-down list, select the entry **Installer** or **User**.
 3. Enter the password in the field **Password**.
 4. Select **Login**.
- The start page of the user interface opens.

Log Out as the User or Installer

1. On the right-hand side of the menu bar, select the menu **User Settings**.
 2. In the subsequent context menu, select [**Logout**].
- The login page of the user interface opens. The logout was successful.

8.3 Start Page Design of the User Interface

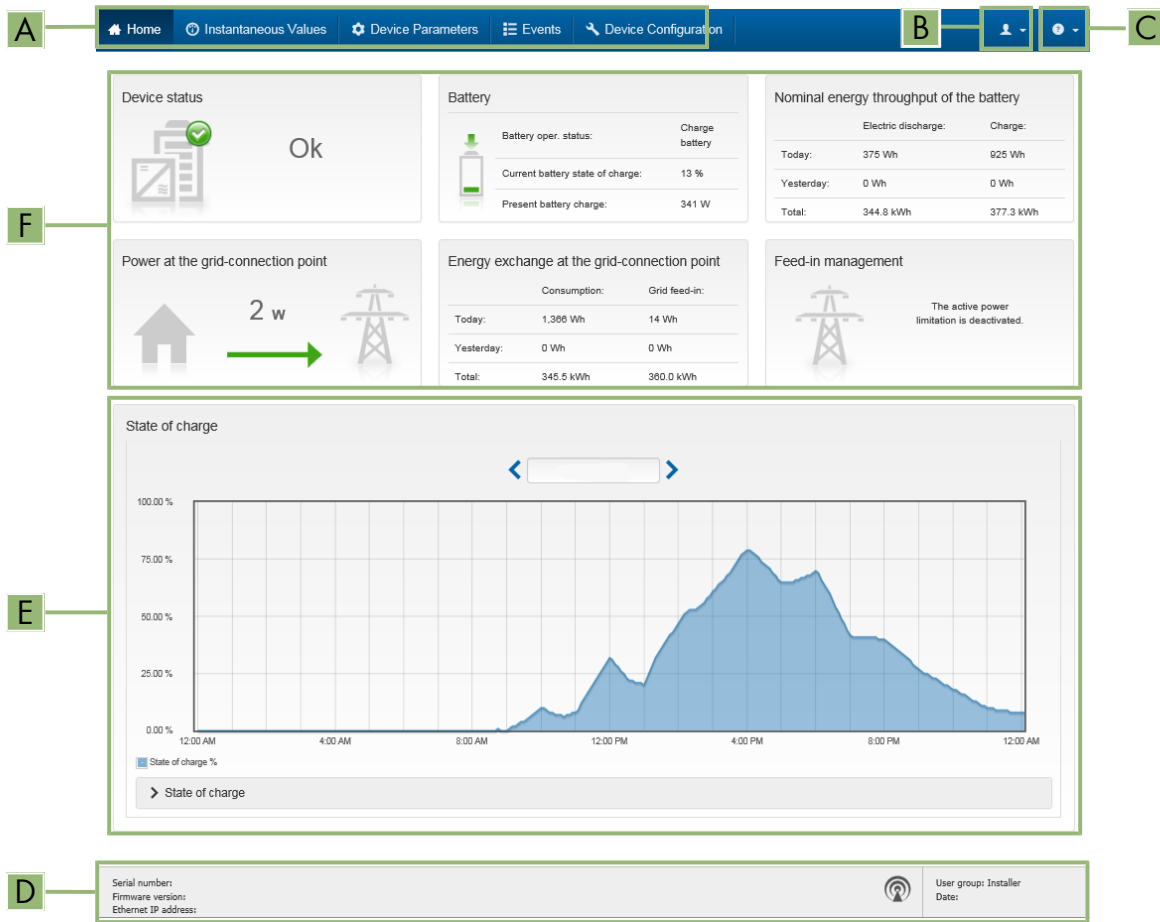

Figure 24: Start page design of the user interface (example)

| Position | Designation | Description |
|----------|---------------|---|
| A | Menu | <p>Provides the following functions:</p> <ul style="list-style-type: none"> • Home Opens the user interface homepage • Instantaneous values Current measured values of the inverter • Device Parameters The various operating parameters of the inverter can be viewed and configured here depending on the user group. • Events All events that have occurred in the selected time period are displayed here. The event types are Information, Warning and Error. Currently existing events of the types Error and Warning will be additionally displayed in the Device status viewlet. However, only the higher-priority event is displayed. If, for example, there is a Warning and an Error present at the same time, only the Error will be displayed. • Device configuration Various settings for the inverter can be made here. The selection available is dependent on which user group you are logged in as and the operating system of the device with which the user interface has been called up. • Data You will find all data that is saved in the internal memory of the inverter or on an external storage medium on this page. |
| B | User settings | <p>Provides the following functions, depending on the user group logged in:</p> <ul style="list-style-type: none"> • Starting the installation assistant • SMA Grid Guard login • Logout |
| C | Help | <p>Provides the following functions:</p> <ul style="list-style-type: none"> • Displaying information on Open Source licenses used • Link to the website of SMA Solar Technology AG |
| D | Status bar | <p>Displays the following information:</p> <ul style="list-style-type: none"> • Inverter serial number • Inverter firmware version • IP address of the inverter within the local network and/or IP address of the inverter during WLAN connection • With WLAN connection: Signal strength of WLAN connection • User group logged in • Date and device time of the inverter |

| Position | Designation | Description |
|----------|-----------------|--|
| E | State of charge | Chronological sequence of the state of charge (SOC) of the battery |
| F | Status display | <p>The various areas display information on the current status of the system.</p> <ul style="list-style-type: none"> • Device status Displays whether the inverter and/or the battery is/are currently in a fault-free operating state or whether there is an event type Error or Warning present. • Feed-in management Displays whether the inverter is currently limiting its active power. • Nominal energy throughput of the battery Indicates how much energy has been charged to the battery and how much has been discharged from the battery. • Battery Displays the following information: <ul style="list-style-type: none"> - Operating status of battery - Current battery state of charge - Current battery charging power • Energy exchange at the grid-connection point Indicates how much energy was obtained from the utility grid to supply the household and how much the PV system fed in. • Power at the grid-connection point Indicates which power is currently fed in or obtained at the grid-connection point. • MC-status system Status of the multicluster system • MC system total power Total active power of all Sunny Island inverters in the multicluster system |

8.4 Changing the Password

The password for the inverter can be changed for both user groups. Furthermore, the user group **Installer** can change the password for the user group **User** as well as its own password.

i PV systems registered in a communication product

With PV systems that are registered in a communication product (e.g. Sunny Portal, Sunny Home Manager), you can also assign a new password for the user group **Installer** via the communication product. The password for the user group **Installer** is also the system password. If you assign a password for the user group **Installer** via the user interface of the inverter that does not correspond to the system password in the communication product, the inverter can no longer be reached by the communication product.

- Ensure that the password for the user group **Installer** is the same as the system password in the communication product.

Procedure:

1. Activate the user interface (see Section 8.1, page 110).
2. Log into the user interface (see Section 8.2, page 112).
3. Call up the menu **Device Parameters**.
4. Select **[Edit parameters]**.

5. In the parameter group **User Rights > Access Control** change the password of the desired user group.
6. Select [**Save all**] to save the changes.

8.5 Forgotten Password

If you have forgotten the password for the inverter, you can unlock the inverter with a Personal Unlocking Key (PUK). For each inverter, there is one PUK for each user group (**User** and **Installer**).

Useful hint: With PV systems in Sunny Portal, you can also assign a new password via Sunny Portal for the user group **Installer**. The password for the user group **Installer** is the same as the system password in Sunny Portal.

Procedure:

1. Request PUK (application form available at www.SMA-Solar.com).
2. Activate the user interface (see Section 8.1, page 110).
3. Enter the PUK instead of the password into the field **Password**.
4. Select **Login**.
5. Call up the menu **Device Parameters**.
6. Select [**Edit parameters**].
7. In the parameter group **User Rights > Access Control** change the password of the desired user group.
8. Select [**Save all**] to save the changes.

i PV Systems in Sunny Portal

The password for the user group **Installer** is also the system password for the PV system in Sunny Portal. Changing the password of the user group **Installer** can lead to the inverter no longer being able to be reached by Sunny Portal.

- Assign the changed password of the user group **Installer** as the new system password in Sunny Portal (see the Sunny Portal user manual at www.SMA-Solar.com).

9 Configuration of the Inverter

9.1 Starting the Installation Assistant

⚠ QUALIFIED PERSON

The installation assistant leads you step-by-step through the steps necessary for the initial configuration of the inverter.

Layout of the installation assistant

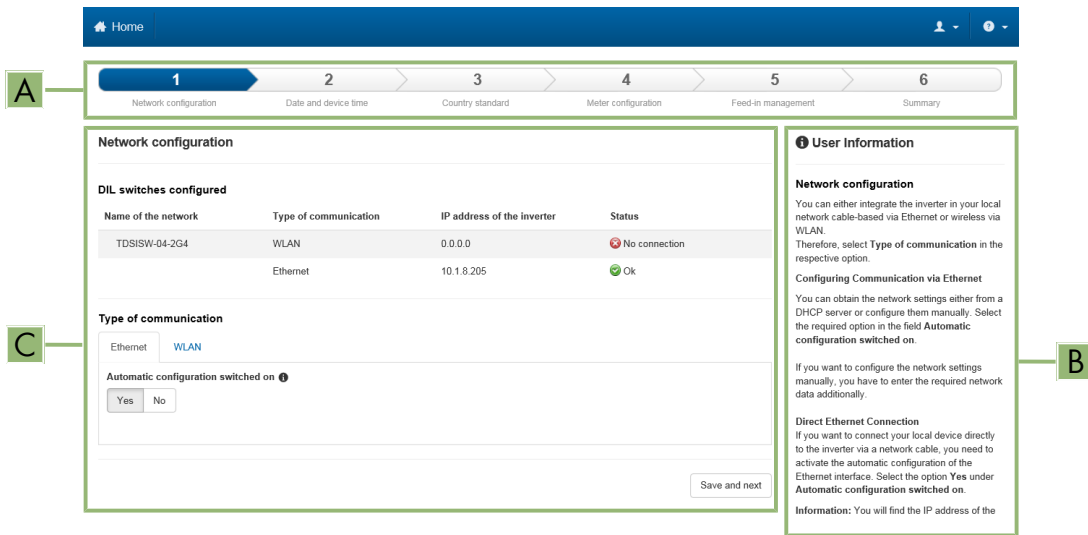

Figure 25: Layout of the installation assistant (example)

| Position | Designation | Description |
|----------|---------------------|--|
| A | Configuration steps | Overview of the installation assistant steps. The number of steps depends on the type of device and the additionally installed modules. The current step is highlighted in blue. |
| B | User information | Information about the current configuration step and the setting options of the configuration step. |
| C | Configuration field | You can make settings in this field. |

Requirement:

- Without the SMA Grid Guard code settings for the utility grid are only possible within the first ten operating hours (see "Measured Values and Parameters" at www.SMA-Solar.com) After completion of the first ten operating hours, the SMA Grid Guard code must be available (see "Application for SMA Grid Guard Code" at www.SMA-Solar.com).

Procedure:

1. Activate the user interface (see Section 8.1, page 110).
 2. Log in as **Installer**.
 3. Select the menu **User Settings** (see Section 8.3, page 114) on the start page of the user interface.
 4. In the context menu, select [**Start the installation assistant**].
- The installation assistant will open.

9.2 Changing Operating Parameters

The operating parameters of the inverter are set to certain values by default. You can change the operating parameters to optimize the performance of the inverter.

This section describes the basic procedure for changing operating parameters. Always change operating parameters as described in this section. Function-sensitive parameters are only visible to qualified persons and can only be changed upon logging in as Installer. These parameters are designated in the user interface with a locked padlock.

NOTICE

Damage to the battery due to incorrect settings

The set battery parameters influence the charging behavior of the inverter. The battery can be damaged by incorrect settings of the battery type, nominal voltage and capacity parameters.

- Set the correct battery type as well as the correct values for nominal voltage and battery capacity when configuring.
- Ensure that the values recommended by the manufacturer are set for the battery (refer to the technical data of the battery in the manufacturer documentation).

i No configuration via Sunny Explorer

Sunny Explorer does not support the configuration of inverters with their own user interface. The inverter can be detected via Sunny Explorer, however it is expressly not recommended to use Sunny Explorer to configure this inverter. SMA Solar Technology AG does not accept liability for missing or incorrect data and possibly resulting yield losses.

- Use the user interface for the configuration of the inverter.

Requirement:

- The SMA Grid Guard code must be available (see "Application for SMA Grid Guard Code" at www.SMA-Solar.com) for making changes to utility-grid-related parameters.

Procedure:

1. Activate the user interface (see Section 8.1, page 110).
 2. Log into the user interface (see Section 8.2, page 112).
 3. Call up the menu **Device Parameters**.
 4. Select [**Edit parameters**].
 5. Log in using the SMA Grid Guard code to change those parameters designated by a lock (only for installers):
 - Select the menu **User Settings** (see Section 8.3, page 114).
 - In the subsequent context menu, select [**SMA Grid Guard login**].
 - Enter the SMA Grid Guard code and select [**Login**].
 6. Expand the parameter group that contains the parameter which is to be configured.
 7. Change the desired parameters.
 8. Select [**Save all**] to save the changes.
- The inverter parameters are set.

9.3 Setting Time-Controlled Inverter Operation in Off-Grid Systems

Time-controlled inverter operation enables the regular supply of loads (e.g. electrical heating) during defined time periods (at weekends). In time-controlled inverter operation, the Sunny Island only makes the stand-alone grid available during the set time period; the Sunny Island is in standby mode for the remaining time.

1. Activate the user interface of the inverter (see Section 8.1, page 110).
 2. Log in as Installer (see Section 8.2, page 112).
 3. Select **Device > Operation > Time control**.
 4. Set time-controlled inverter operation:
 - Set the parameter **Start date for time-controlled inverter operation** to the desired start date.
 - Set the parameter **Start time for time-controlled inverter operation** to the desired start time.
 - Set the parameter **Operating time for time-controlled inverter op.** to the desired operating time.
 - Select the **Repetition cycle for time-controlled inverter operation / Repetition** parameter and set it to the desired repetition cycle.
 5. To activate time-controlled inverter operation, select the parameter **Time-controlled inverter operation** and set it **Yes**.
- Time-controlled inverter operation is active. If the Sunny Island has started automatically under time-control and you stop the Sunny Island, time-controlled inverter operation is deactivated automatically.

9.4 Activate WPS Function

- Activate the WPS function on the inverter. To do this, tap on the enclosure lid of the inverter twice.
 - A signal sounds for one second followed by a one second break. After this break the signal sounds again for one second.

The inverter deactivates the WPS function automatically. When this happens, a signal sounds: long signal (one second) > break (one second) > very long signal (three seconds).

9.5 Switching WLAN On and Off

The inverter is equipped with an activated WLAN interface as standard. If you do not want to use WLAN, you can switch the WLAN function off and switch it on again whenever needed. In doing so, you can switch the WLAN direct connection and the WLAN connection in the local network on independently of each other.

i Switching on the WLAN function only possible via Ethernet connection

If you switch off both the WLAN function for the direct connection and for the connection in the local network, access to the inverter user interface and therefore reactivation of the WLAN interface is only possible via an Ethernet connection.

The basic procedure for changing operating parameters is explained in another section (see Section 9.2 "Changing Operating Parameters", page 119).

Switching WLAN Off

If you would like to switch the WLAN function off completely, you must switch off both the direct connection and the connection in the local network.

Procedure:

- To switch off the direct connection in the parameter group **PV system communication > WLAN**, select the parameter **Soft-access-point is turned on** and set this to **No**.
- To switch off the connection in the local network in the parameter group **PV system communication > WLAN**, select the parameter **WLAN is turned on** and set this to **No**.

Switching WLAN On

If you have switched the WLAN function for direct connection or for connection in the local network off, you can switch the WLAN function back on in accordance with the following procedure.

Requirement:

- If the WLAN function was previously switched off completely, the inverter must be connected to a computer or router via Ethernet.

Procedure:

- To switch on the WLAN direct connection, in the parameter group **PV system communication > WLAN**, select the parameter **Soft-access-point is turned on** and set this to **Yes**.
- To switch on the WLAN connection in the local network, in the parameter group **System communication > WLAN**, select the parameter **WLAN is turned on** and set this to **Yes**.

9.6 Configuring the Energy Meter

⚠ QUALIFIED PERSON

You can add an energy meter to your PV system or replace an existing energy meter.

The basic procedure for changing operating parameters is explained in another section (see Section 9.2 "Changing Operating Parameters", page 119).

i Removing a detected energy meter from the PV system

If only one energy meter is detected by the inverter, this will be added to the PV system automatically. Removal via the menu **Device configuration** is not possible in this case. To remove the energy meter from the PV system, proceed as follows:

- In the parameter group **System communication > Measured values > Meter on Speedwire**, set the parameter **Serial number** to any number (e.g. **1**). In this way, instead of the energy meter detected, the PV system will add a fictitious energy meter to which the inverter cannot establish communication.

Procedure:

1. Activate the user interface (see Section 8.1, page 110).
2. Log in as **Installer**.
3. Start the installation assistant (see Section 9.1, page 118).
4. In the context menu, select [**Starting the installation assistant**].
5. Select [**Save and next**] until you get to the step **Meter configuration**.
6. Add or replace the desired energy meter.

9.7 Configuring the Modbus Function

⚠ QUALIFIED PERSON

The Modbus interface is deactivated by default and the communication ports 502 set.

In order to access SMA inverters with SMA Modbus[®], the Modbus interface must be activated. After activating the interface, the communication ports of the IP protocol can be changed. For information on commissioning and configuration of the Modbus interface, see the technical information "SMA Modbus[®] Interface" at www.SMA-Solar.com.

For information on which Modbus registers are supported, see the technical information "SMA Modbus[®] Interface" at www.SMA-Solar.com.

i Data security during activated Modbus interface

If you activate the Modbus interface, there is a risk that unauthorized users may access and manipulate the data or devices in your PV system.

- Take appropriate protective measures, such as:
 - Set up a firewall.
 - Close unnecessary network ports.
 - Only enable remote access via VPN tunnel.
 - Do not set up port forwarding at the communication port in use.
 - In order to deactivate the Modbus interface, reset the inverter to default settings or deactivate the activated parameter again.

i Deactivate the dynamic active power limitation for the PV inverters when controlled via Modbus

If the PV inverters and the battery inverter are controlled in a PV system via Modbus, the dynamic active power limitation of the PV inverters must be deactivated.

Procedure:

- Activate the Modbus interface and adjust the communication ports if necessary (see the technical information "SMA Modbus® Interface" at www.SMA-Solar.com).

9.8 Supplementary Information

9.8.1 Determining the Battery Capacity

Manufacturers state the battery capacity depending on the discharge time. In the **installation assistant** and in parameter **Rated battery capacity**, always specify the battery capacity for a ten hour electric discharge (C10).

Procedure:

- Determine the battery capacity C10 specified by the battery manufacturer.
 - You could determine the battery capacity C10.
 - You could not determine the battery capacity C10?
 - Estimate the battery capacity C10 from other discharge times. This will provide a value that is probably sufficient for commissioning.

| Discharging time | Estimation |
|------------------|---------------------|
| 120 h (C120) | $C10 = C120 / 1.28$ |
| 100 h (C100) | $C10 = C100 / 1.25$ |
| 20 h (C20) | $C10 = C20 / 1.09$ |
| 10 h (C10) | $C10 = C10$ |
| 5 h (C5) | $C10 = C5 / 0.88$ |
| 1 h (C1) | $C10 = C1 / 0.61$ |

- Contact the battery manufacturer, request the C10 battery capacity and set the correct battery capacity in the installation assistant as soon as possible. Proceed as if you were replacing the battery (replacing the battery, see Sunny Island operating manual).

9.8.2 Setting Time-Dependent Functions

Time-dependent functions, such as time-dependent load shedding, split the day into two time periods. You specify the time periods using two points in time. The standard time period starts with time 1 and ends with time 2. The additional time period starts with time 2 and ends with time 1.

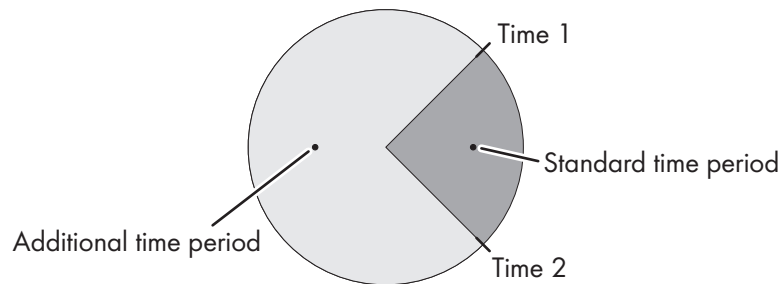

Figure 26: Division of the time of day into two time periods

9.8.3 Setting Time-Controlled Functions

For time-controlled functions, you set the start time, duration and repetition type.

Example: Time-controlled operation of a generator

If you want the generator to run every Monday from 07:00 a.m. to 08:00 a.m., Set the generator as follows:

- **Time-controlled generator operation:** Yes (activation of the function)
 - **Start time for time-controlled generator op.:** 2015-01-05 (Monday)
 - **Start time for time-controlled generator operation:** 07:00:00 (starting time)
 - **Operating time for time-controlled generator op.:** 01:00:00 (duration)
 - **Repeat cycle of time-controlled generator op.:** Weekly (repetition type)
-

10 Starting and Stopping the System

10.1 Switching on the Sunny Island

Requirements:

- All Sunny Island inverters must be closed (see Section 14.11, page 142).
- The fuse switch-disconnector of the battery fuse must be closed (see Section 6.9, page 73).
- The Sunny Island must not have switched itself off (see Section 14.7 "Charging the Battery After Automatic Shutdown in Off-Grid Systems (Emergency Charge Mode)", page 137).

Procedure:

- For systems with one Sunny Island, press the "On" button on the Sunny Island.

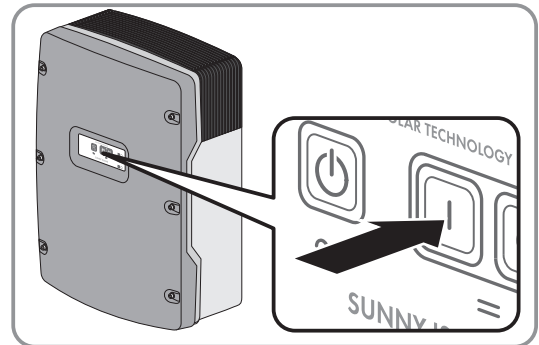

- For systems with up to three Sunny Island inverters, press and hold the "On" button on the master until an acoustic signal sounds.
- For multicluster systems, press and hold the "On" button on each master until an acoustic signal sounds.
 - The inverter LED on each Sunny Island inverter is glowing orange and the Sunny Island inverters are in standby mode.

10.2 Starting the System

Requirements:

- All Sunny Island inverters must be switched on.
- The circuit breakers for the AC sources in the stand-alone grid must be switched off in the AC distribution board.
- The load-break switch of the PV array must be open.

Procedure:

- For systems with one Sunny Island, press the "start-stop" button on the Sunny Island until an acoustic signal sounds.

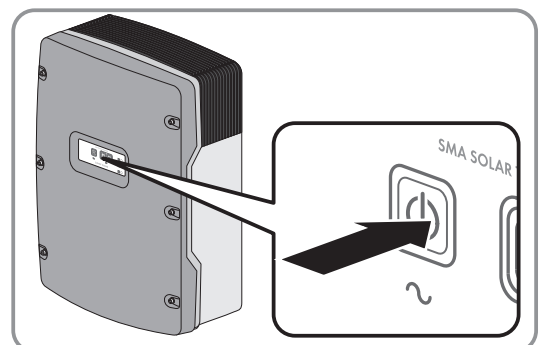

- For systems with up to three Sunny Island inverters, press and hold the "start-stop" button on the master.
- For multicluster systems, press and hold the "start-stop" button on the master of the main cluster until an acoustic signal sounds.
 - The inverter LED on each Sunny Island is glowing green. The Sunny Island inverters are in operation.

10.3 Stopping the System

If you stop the system, the Sunny Island switches from operation into standby mode. In standby mode, the Sunny Island discharges the battery due to its standby consumption. Tip: For longer shut-down periods, switch off the Sunny Island (see Section 10.4, page 125).

Procedure:

- For systems with one Sunny Island, press the "start-stop" button on the Sunny Island until an acoustic signal sounds.

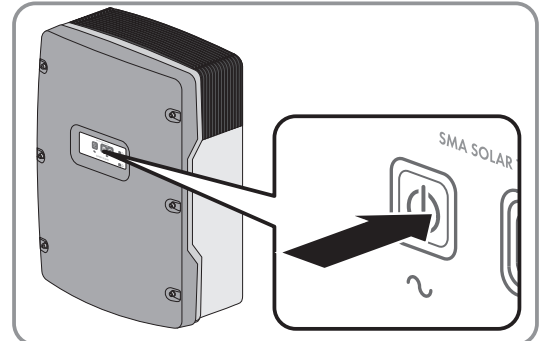

- For systems with up to three Sunny Island inverters, press and hold the "start-stop" button on the master until an acoustic signal sounds.
- For multicluster systems, press and hold the "start-stop" button on the master of the main cluster until an acoustic signal sounds.
 - ☑ The inverter LED on each Sunny Island is glowing orange. The Sunny Island inverters are in standby mode.

10.4 Switching Off the Sunny Island

Requirements:

- ☐ The system is stopped.

Procedure:

- For systems with one Sunny Island inverter, press and hold the "Off" button until an acoustic signal sounds.

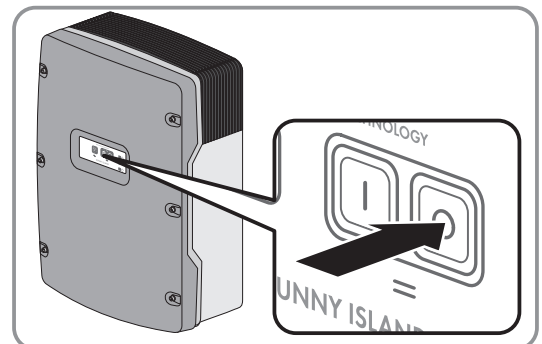

- For systems with up to three Sunny Island inverters, press and hold the "Off" button on the master until an acoustic signal sounds.
- For multicluster systems, press and hold the "Off" button on each master until an acoustic signal sounds.
 - ☑ The inverter LED is off on all Sunny Island inverters.

10.5 Tripping the Emergency Disconnection of the System

i Effects of an emergency disconnection

Emergency disconnection triggers the uncontrolled shutdown of the system and unsaved data is lost.

- Only trip the emergency disconnection to avoid danger or consequential damage.
- In the event of an emergency disconnection in a multicluster system, always check whether any fuse elements in the Multicluster-Box, such as circuit breakers, have tripped. If any fuse elements have tripped, reactivate these fuse elements.

Procedure:

- For systems with one Sunny Island, press the "Off" button on the Sunny Island.

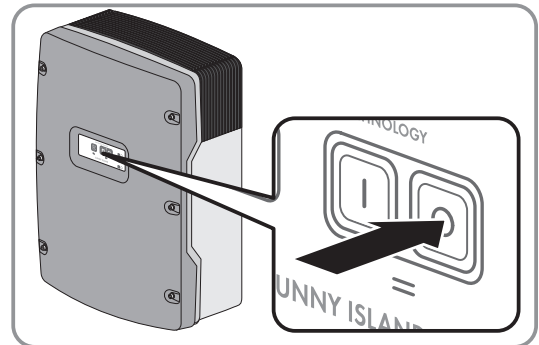

- For systems with up to three Sunny Island inverters, press the "Off" button on the master.
- For multicluster systems, press and hold the "Off" button on the master of the main cluster.
 - The inverter LED is off on all Sunny Island inverters.

11 Data Storage and Firmware Update

11.1 Viewing Event Messages or Instantaneous Values

Event messages and instantaneous values are saved in the Sunny Island. This data can be evaluated and thus the operating processes in the Sunny Island system can be traced. From this, for example, parameter settings can be derived that will e.g. increase the self-consumption of PV energy or the service life of the battery. For SMA Service, this data simplifies the analysis of any errors present and the identification of possible solutions.

The storage capacity of the inverter can be extended with the optional micro SD card. Thus, for example, data can be recorded over longer time periods, enabling extended diagnostics possibilities to be used (see Section 17.13, page 186).

Procedure:

1. Activate the user interface of the individual inverter or the user interface of the master in a cluster (see Section 8.1 "Establishing a connection to the user interface", page 110).
2. Log in as **Installer** or **User**.
3. To call up event messages, select the menu **Events**.
4. To call up instantaneous values, select the menu **Data**.
5. Follow the instructions in the user interface.

11.2 Exporting Event Messages

With this function, you can save the events of your system to the computer as CSV files.

Procedure:

1. Activate the user interface of the individual inverter or the user interface of the master in a cluster (see Section 8.1 "Establishing a connection to the user interface", page 110).
2. Log in as **Installer** or **User**.
3. Select the menu **Events**.
4. To filter event messages, activate or deactivate the filters **Information** / **Warning** / **Error** as necessary.
5. Select the button [**Export events**].
6. Follow the additional instructions in the user interface.

11.3 Exporting Parameters

With this function, you can save the events of your system to the computer as HTML files.

Procedure:

1. Activate the user interface of the individual inverter or the user interface of the master in a cluster (see Section 8.1 "Establishing a connection to the user interface", page 110).
2. Log in as **Installer** or **User**.
3. Select the menu **Device Parameters**.
4. Select the button [**Parameter export**].
5. Follow the additional instructions in the user interface.

11.4 Updating the Firmware

QUALIFIED PERSON

If there is not an automatic update enabled for the inverter in the communication product (e.g. Sunny Home Manager) or in Sunny Portal, you can update the inverter firmware as described in the following.

Requirement:

- To update the inverter firmware, the update file with the desired inverter firmware must be available. The update file is, for example, available for download on the product page of the inverter at www.SMA-Solar.com. To download the update file, it is necessary to enter the serial number of the inverter.

Procedure:

1. Activate the user interface (see Section 8.1, page 110).
2. Log into the user interface (see Section 8.2, page 112).
3. Update the inverter firmware:
 - Select the menu **Device Configuration**.
 - In the inverter row, click on the gear icon and select **Update firmware**.
 - Select [**Browse**] and select the update file for the inverter.
 - Select **Update firmware**.
 - Follow the instructions in the dialog.
- The inverter firmware has been updated.

11.5 Saving the Configuration in a File

You can save the current configuration of the inverter in a file and use this file as a backup for this inverter. When saving, only the device parameters will be saved, not any passwords.

You can import the saved file to configure the inverter. When doing so, however, no settings can be overwritten from the installation assistant. For single-cluster systems, you must perform the data import on the master.

Procedure:

1. Activate the user interface (see Section 8.1, page 110).
2. Log into the user interface (see Section 8.2, page 112).
3. Select the menu **Device Configuration**.
4. Select [**Settings**].
5. In the context menu, select [**Saving the configuration in a file**].
6. Follow the instructions in the dialog.

11.6 Adopting a Configuration from a File

QUALIFIED PERSON

To configure the inverter, you can adopt the configuration from a file (see Section 11.5 "Saving the Configuration in a File", page 128). When doing so, however, no settings from the installation assistant and no passwords can be overwritten. For single-cluster systems, you must perform the data import on the master.

Requirements:

- The SMA Grid Guard code must be available (see "Application for SMA Grid Guard Code" at www.SMA-Solar.com). A charge is levied for this code.
- Changes to grid-relevant parameters must be approved by the responsible grid operator.

Procedure:

1. Activate the user interface (see Section 8.1, page 110).
2. Log into the user interface as an **Installer**.
3. Select the menu **Device Configuration**.
4. Select [**Settings**].

5. In the context menu, select [**Adopting the configuration from a file**].
6. Follow the instructions in the dialog.

12 Manually Controlling the Generator

12.1 Starting the Generator via the User Interface

The basic procedure for changing operating parameters is explained in another section (see Section 9.2 "Changing Operating Parameters", page 119).

Requirement:

- The Sunny Island must be able to control the generator via a control cable.

Procedure:

1. Select **Generator > Generator**.
2. Set the parameter **Manual generator control** to **Start**.
 - The electricity generator starts and runs until you stop it again.
3. To start the generator and leave it running for one hour, perform the following steps.
 - Select **Generator > Operation >**.
 - Set the parameter **Reason for requesting generator** to **Run1h**.
 - The generator starts. If there is no generator request after one hour, the Sunny Island stops the generator.

12.2 Stopping the Generator via the User Interface

⚠ WARNING

Risk of crushing injuries due to moving PV array parts

A generator can be started automatically by the Sunny Island. Moving parts in the PV array can crush or sever body parts.

- Operate the generator only with the specified safety equipment.
- Carry out all work on the generator in accordance with the manufacturer's specifications.

The basic procedure for changing operating parameters is explained in another section (see Section 9.2 "Changing Operating Parameters", page 119).

Requirement:

- The Sunny Island must be able to control the generator via a control cable.

Procedure:

1. Select **Generator > Generator**.
2. Set the parameter **Manual generator control** to **Stop**.
 - The generator is stopped temporarily. The generator restarts when a generator request is issued in automatic generator mode and the minimum stop time has elapsed.
3. To stop the generator permanently, deactivate the automatic generator mode:
 - Select **Generator > Generator**.
 - Set the parameter **Automatic generator start** to **Off**.

12.3 Starting the Generator without Autostart Function

1. Start the generator (see manufacturer's manual).
2. Close the load-break switch between the generator and Sunny Island.
- After the warm-up period, the Sunny Island connects the stand-alone grid to the generator.

12.4 Stopping the Generator without Autostart Function

1. Stop the generator via the user interface (see Section 12.2, page 130). When you do this, the Sunny Island disconnects the stand-alone grid from the generator.
2. Open the load-break switch between the generator and the Sunny Island.
3. Stop the generator (see manufacturer's manual).
 - The generator is stopped. After the power-down time and the minimum stop time, you can use the generator again.

13 Disconnecting the Sunny Island from Voltage Sources

⚠ QUALIFIED PERSON

1. Stop the system (see Section 10.3, page 125).
2. Switch off the Sunny Island (see Section 10.4, page 125).
3. Disconnect the circuit breakers and the load-break switches in the sub-distributions and secure against reconnection.
4. Open the load-break switch in the DC cable and secure against reconnection.

5. **NOTICE**

Destruction of the Sunny Island inverter due to electrostatic discharge (ESD)

By touching electronic components within the Sunny Island, you can damage or destroy the Sunny Island.

- Ground yourself before touching any component.

6. Loosen all screws of the enclosure lid and remove the enclosure lid.
7. Ensure that the **DC** connection is disconnected from voltage sources (see Section 6.2, page 31).
8. Ensure that the terminals **AC1 Loads/SunnyBoys** and **AC2 Gen/Grid** are disconnected from voltage sources (see Section 6.2, page 31).
9. Ensure that the **ExtVtg** is disconnected from voltage sources (see Section 6.2, page 31).
10. Ensure that the connections **Relay1** and **Relay2** are disconnected from voltage sources (see Section 6.2, page 31).
11. Ground and short-circuit the AC power cables outside the Sunny Island.
12. Cover or isolate any adjacent live components.

14 Cleaning and Maintenance

14.1 Cleaning and Checking the Sunny Island Inverter Enclosure

NOTICE

Damage to the inverter due to the use of cleaning agents

- If the inverter is dirty, clean the enclosure, the enclosure lid, the type label and the LEDs using only clean water and a cloth.
- Ensure that the inverter is free of dust, foliage and other dirt. Carefully remove heavy dirt with a soft brush.

14.2 Checking the Function

Testing period

- For new systems, check every week during the six months following commissioning whether error messages have been logged. This will reveal any hidden errors in the installation or configuration.
- For all other systems, check every six months whether error messages have been logged.

Procedure:

1. Activate the user interface of the inverter (see Section 8.1, page 110).
2. Log in as User (see Section 8.2, page 112).
3. Select the menu **Events**.
4. Set filter:
 - Activate **Warning** and **Error**.
 - Deactivate **Information**.
5. Set the desired time period and select [**Apply time filter**].
6. If error messages have been logged, eliminate the cause (see Section 15.2, page 145).

14.3 Checking the Connections

⚠ QUALIFIED PERSON

⚠ DANGER

Danger to life from electric shock due to high voltages

High voltages are present inside the inverter. When the enclosure lid is removed, live components can be touched that can result in death or serious injury due to electric shock.

- Disconnect the inverter from all voltage sources (see Section 13, page 132).
- After switching off the inverter, wait at least 15 minutes before opening the inverter to allow the capacitors to discharge completely.

1. Make sure the Sunny Island is dead. (see Section 13, page 132).
2. Ensure that the cables on the **DC+** and **DC-** connections are securely fastened (torque: 12 Nm).
3. Ensure that the connections are free of corrosion.
4. Ensure that the cables in the **AC1** and **AC2** connections are securely fastened.
5. Close the Sunny Island (see the Sunny Island inverter installation manual).
6. Switch on all load-break switches and circuit breakers (see Section 14.12, page 143).

14.4 Cleaning the Fans

⚠ QUALIFIED PERSON

If the user interface displays the warning **Derating due to temp.** unusually often, it is likely that one of the fans is defective or blocked.

Procedure:

- Clean the ventilation grids.
- Clean the fans.

Cleaning the Ventilation Grids

Proceed as follows to clean each ventilation grid.

Procedure:

1. Remove the ventilation grid laterally.

2. **NOTICE**

Damage to the inverter due to foreign bodies

- Do not remove the ventilation grid permanently, otherwise foreign bodies could penetrate the enclosure.
3. Clean the ventilation grid with a soft brush, a paint brush, or compressed air.
 4. Close the recessed grips with the ventilation grids. Ensure that the assignment is correct. The correct assignment is marked on the inside of each ventilation grid: **links/left** for the left-hand side and **rechts/right** for the right-hand side.

Cleaning the Fans

Proceed as follows to clean each fan.

⚠ DANGER

Danger to life from electric shock due to high voltages

High voltages are present inside the inverter. When the enclosure lid is removed, live components can be touched that can result in death or serious injury due to electric shock.

- Disconnect the inverter from all voltage sources (see Section 13, page 132).
- After switching off the inverter, wait at least 15 minutes before opening the inverter to allow the capacitors to discharge completely.

1. Disconnect the Sunny Island from voltage sources (see Section 13, page 132).
2. Wait for the fans to stop rotating.
3. Check whether the fan guard is dusty or badly clogged.

If the fan guard is dusty, clean it with a vacuum cleaner or a soft brush.

If the fan guard is heavily soiled, remove it and clean it:

- Use a screwdriver to push the two locking tabs at the right-hand edge of the fan guard to the right-hand side and remove them from the retainer.

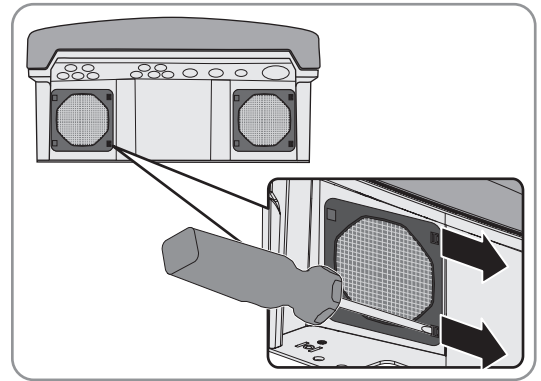

- Carefully remove the fan guard.
- Clean the fan guard with a soft brush, a paint brush, a cloth or compressed air.

4. Check whether the fan is soiled.

If the fan is soiled, remove the fan:

- Use a screwdriver to push the two locking tabs at the right-hand edge of the fan guard to the right-hand side and remove them from the retainer.

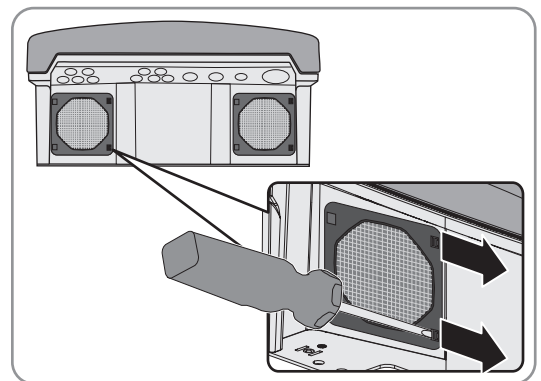

- Carefully remove the fan guard.
- Push the front locking tabs of the fan backwards and the rear locking tabs of the fan forwards.

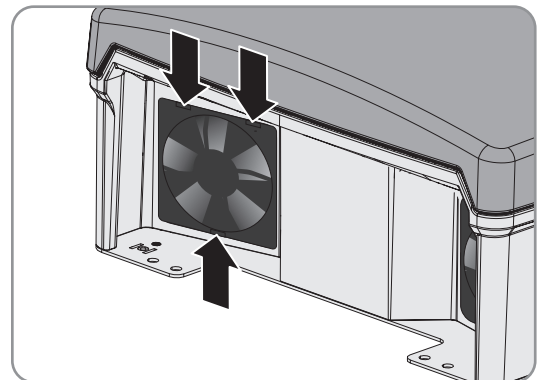

- Slowly remove the fan from the Sunny Island.
- Release and remove the fan plug.

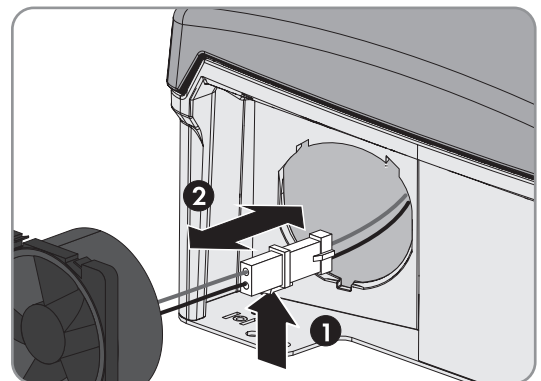

5. **NOTICE****Damage to the fan due to compressed air**

- Clean the fan with a soft brush, a paint brush, or a damp cloth.
6. Insert the plug of the fan in the pin connector until it snaps into place.
 7. Insert the fan into the Sunny Island until the fan audibly snaps into place.
 8. Press the fan guard into the bracket until it audibly snaps into place.

14.5 Performing a Manual Equalization Charge in the Off-Grid System

After extended periods without charging (e.g., systems operated seasonally), perform a manual equalization charge at the end or start of the season.

The basic procedure for changing operating parameters is explained in another section (see Section 9.2 "Changing Operating Parameters", page 119).

Procedure:

1. Select **Battery > Battery > Operation**.
2. Set the parameter **Manual equalization charge** to **Start**.

14.6 Checking and Maintaining the Battery

⚠ QUALIFIED PERSON

⚠ WARNING

Chemical burns and poisoning due to battery electrolyte

If handled inappropriately, battery electrolyte can cause irritation to the eyes, respiratory system and skin, and it can be toxic. This may result in blindness or serious chemical burns.

- Protect the battery enclosure against destruction.
- Do not open or deform the battery.
- Do not throw batteries into fire. Batteries may explode in fire.
- Whenever working on the battery, wear suitable personal protective equipment such as rubber gloves, an apron, rubber boots and goggles.
- Rinse acid splashes thoroughly for a long time with clear water, and consult a doctor.
- Install, operate, maintain and dispose of the battery according to the manufacturer's specifications.

⚠ WARNING

Risk of burns due to flashes

Short-circuit currents in the battery can cause heat build-up and flashes.

- Remove watches, rings and other metal objects prior to carrying out any work on the battery.
- Use insulated tools for all work on the battery.
- Do not place tools or metal parts on the battery.

i Check and log the status of the battery before performing maintenance work.

Transition resistances can impair the performance of the batteries.

- Ensure that the torques at the battery connections are correct each time that maintenance is performed.

Procedure:

1. Check whether the current state of the battery corresponds to the expected state:
 - In the parameter group **Battery > Battery > Diagnosis**, select the parameter **Number of battery charge throughputs** and compare the value with the expected nominal energy throughput.
 - In the parameter group **Battery > Battery > Diagnosis**, select the parameter **Current battery capacity** and compare the value with the expected usable battery capacity.

If the current state of the battery does not correspond to the expected state, carry out the following steps:

- Ensure that the requirements for the ambient temperature of the battery are met (see documentation of the battery manufacturer).
 - Check and optimize the battery management settings.
 - If you cannot determine the cause for the deviation, contact the Service (see Section 19 "Contact", page 189).
2. Stop the system and switch off the Sunny Island (see Section 10 "Starting and Stopping the System", page 124).
 3. Open the load-break switch of the BatFuse and secure against reconnection.
 4. Check and maintain the battery (see documentation of the battery manufacturer).
 5. Quickly close the load-break switch of the BatFuse and close the BatFuse (see BatFuse installation manual).
 6. Switch the Sunny Island on and start the system (see Section 10 "Starting and Stopping the System", page 124).

14.7 Charging the Battery After Automatic Shutdown in Off-Grid Systems (Emergency Charge Mode)

QUALIFIED PERSON

When a battery undergoes deep discharge, the Sunny Island shuts down automatically and you cannot restart the Sunny Island. In order to start the Sunny Island again after an automatic shutdown, you must charge the battery in emergency charge mode.

In emergency charge mode, the Sunny Island does not form a separate stand-alone grid, and you can charge the battery using a generator. Battery management is active in emergency charge mode and the Sunny Island charges the battery in accordance with the parameter settings. Via the user interface, you can adjust the parameters for the battery, e.g. the battery nominal voltage, if a battery cell fails.

WARNING

Danger to life due to fire or explosion when charging a deep discharged lithium-ion battery.

The charging of a deep discharged lithium-ion battery can lead to its destruction. Death or lethal injuries can result.

- Verify that the lithium-ion battery is not deep discharged (see lithium-ion battery manual).
- Only charge in accordance with the specifications of the battery manufacturer (see lithium-ion battery manual).
- Only run the emergency charge mode with Sunny Island after approval from the battery manufacturer.

DANGER

Danger to life from electric shock due to high voltages

High voltages are present inside the inverter. When the enclosure lid is removed, live components can be touched that can result in death or serious injury due to electric shock.

- Disconnect the inverter from all voltage sources (see Section 13, page 132).
- After switching off the inverter, wait at least 15 minutes before opening the inverter to allow the capacitors to discharge completely.

i Restricted management functions in emergency charge mode

In emergency charge mode, the generator management is not active. The limits for voltage, current and frequency are not monitored. Set the maximum current consumption of the Sunny Island inverter for charging the battery in emergency charge mode. The Sunny Island does not record additional strain on the generator due to loads.

Requirements:

- The system must be an off-grid system.
- The system must be a single system (single-phase system with Sunny Island).
- Lead-acid batteries must be connected (for emergency charge mode of a lithium-ion battery see documentation of the battery manufacturer).

Procedure:

- Connect the generator to connection **AC1**.
- Charge the battery.
- Disconnect the generator from connection **AC1**.
- Start the off-grid system.

Connecting the Generator to Connection AC1

1. Disconnect the inverter from all voltage sources (see Section 13, page 132).
2. Open the inverter (see Section 14.11, page 142).
3. If the system is a single-cluster system (single-phase or three-phase), the master must temporarily be connected as single system (see quick reference guide "Off-Grid Systems" of the Sunny Island inverter).
4. If the system is a multicluster system (single-phase or three-phase), the master of the main cluster must temporarily be connected as single system (see quick reference guide "Off-Grid Systems" of the Sunny Island inverter).
5. If a generator is installed permanently in the off-grid system, bridge the connections **AC1** and **AC2**.
6. If a mobile generator is used, connect the generator to connection **AC1** (see the Sunny Island inverter installation manual).

Close the Sunny Island (see Section 14.11, page 142).

Charging the Battery

1. Ensure that all loads are switched off.
2. Connect or close all circuit breakers and fuse switch-disconnectors for energy sources.
3. Quickly close the load-break switch of the BatFuse and close the BatFuse (see BatFuse installation manual).
4. Start the generator.
5. Switch the Sunny Island on (see Section 10.1, page 124).
6. Activate the user interface of the inverter (see Section 8.1, page 110).
7. Log in as **Installer** (see Section 8.2, page 112).
8. Start the installation assistant.
9. Select [**Save and next**] for each step up to the step **Battery configuration**.
10. Select the button [**New battery configuration**].
11. Ensure that the parameters **Type**, **Voltage**, and **Nominal capacity** are set correctly (see battery manufacturer documentation).
12. Set the parameter **Nominal current** to the nominal current of the generator.
13. Start the battery emergency charge. To do so, select the [**Emergency charge**] button.

Disconnecting the generator from connection AC1

1. Switch the Sunny Island off (see Section 10.4 "Switching Off the Sunny Island", page 125).
2. Ensure that the generator is stopped permanently.

3. **WARNING**

Danger to life from electric shock due to high voltages

High voltages are present on the AC power cables and on the control cables. Touching live components can result in death or serious injury due to electric shock.

- Disconnect the Sunny Island from voltage sources (see Section 13, page 132).
4. If the connections **AC1** and **AC2** are bridged, remove the bridge.
 5. If a mobile generator is used, disconnect the generator from connection **AC1**.
 6. If the system is a single-cluster system (single-phase or three-phase) or a multicluster system, restore the system-specific connection (see quick reference guide of the used system).
 7. Close the Sunny Island (see Section 14.11, page 142).

Starting the Off-Grid System

- Recommission the inverter (see Section 14.12, page 143).

14.8 Changing Slave Addresses in a Cluster

QUALIFIED PERSON

If you want to change slave addresses (e.g. after replacing a Sunny Island inverter), you can assign the slaves a new address via the user interface. Only the address is changed; all other configurations remain as they were, e.g., assignment of the clusters in a multicluster system. When replacing a master, you must reconfigure the cluster (see the quick reference guide for the relevant system for configuring single-cluster operation or multicluster operation).

Requirements:

- All Sunny Island inverters must be switched off.

Procedure:

1. Switch the slaves on first, and then the master (see Section 10.1, page 124).
2. Activate the user interface of the inverter (see Section 8.1, page 110).
3. Log in as **Installer** (see Section 8.2, page 112).
4. Start the installation assistant.
5. Select [**Save and next**] for each step up to the step **System setup**.
6. For a single-phase system, set the parameter **Type** to **Single phase**.
7. For a three-phase system, set the parameter **Type** to **Three phase**.
8. Under **System devices**, set the parameters **Serial number** and **Phase assignment** as follows.

| Serial number | Phase assignment |
|-----------------------------|-------------------|
| Serial number of the master | Line conductor L1 |
| Serial number slave 1 | Line conductor L2 |
| Serial number slave 2 | Line conductor L3 |

9. Select [**Save and next**] until the installation assistant closes.
10. Start the system (see Section 10.1, page 124).

14.9 Replacing the Battery

⚠ QUALIFIED PERSON

⚠ WARNING

Risk of burns due to flashes

Short-circuit currents in the battery can cause heat build-up and flashes.

- Remove watches, rings and other metal objects prior to carrying out any work on the battery.
- Use insulated tools for all work on the battery.
- Do not place tools or metal parts on the battery.

⚠ WARNING

Danger to life due to incompatible lithium-ion battery

An incompatible lithium-ion battery can lead to a fire or an explosion. With incompatible lithium-ion batteries, it is not ensured that battery management is intrinsically safe and will protect the battery.

- Ensure that the lithium-ion batteries are approved for use with the Sunny Island (see technical information "List of Approved Batteries" at www.SMA-Solar.com).
- If no lithium-ion batteries approved for the inverter can be used, lead-acid batteries can be used.
- Verify that the battery complies with locally applicable standards and directives and is intrinsically safe.

⚠ WARNING

Chemical burns and poisoning due to battery electrolyte

If handled inappropriately, battery electrolyte can cause irritation to the eyes, respiratory system and skin, and it can be toxic. This may result in blindness or serious chemical burns.

- Protect the battery enclosure against destruction.
- Do not open or deform the battery.
- Do not throw batteries into fire. Batteries may explode in fire.
- Whenever working on the battery, wear suitable personal protective equipment such as rubber gloves, an apron, rubber boots and goggles.
- Rinse acid splashes thoroughly for a long time with clear water, and consult a doctor.
- Install, operate, maintain and dispose of the battery according to the manufacturer's specifications.

NOTICE

Damage to the battery due to incorrect settings

The set battery parameters influence the charging behavior of the Sunny Island inverter. The battery can be damaged by incorrect settings of the battery type, nominal voltage and capacity parameters.

- Ensure that the values recommended by the manufacturer are set for the battery (refer to the technical data of the battery in the manufacturer documentation). Note that the battery charging behavior names used by SMA Solar Technology AG and the battery manufacturer may, in some cases, differ in meaning (for the battery charging behavior of the Sunny Island inverter, see technical information "List of Approved Batteries").
- Set the battery capacity for a ten-hour electric discharge (C10). The battery manufacturer specifies the battery capacity in relation to discharge time.

i Check and log the status of the battery before performing maintenance work.

Transition resistances can impair the performance of the batteries.

- Ensure that the torques at the battery connections are correct each time that maintenance is performed.

Procedure:

1. Stop the system and switch off the Sunny Island (see Section 10, page 124).
2. Ensure that the battery is not grounded unintentionally.
If the battery is unintentionally grounded, identify the connection between the battery and ground potential and remove the unintentional connection. This helps to prevent electric shock caused by malfunction of other system devices.
3. Open the load-break switch of the battery fuse and secure against reconnection.
4. Remove the battery to be replaced (see battery manufacturer's manuals).
5. Mount and connect the new battery (see manuals of the battery manufacturer). The battery must comply with the technical requirements of the Sunny Island inverter (refer to the Sunny Island inverter installation manual for technical data of the DC connection).
6. Quickly close the load-break switch of the battery fuse and close the battery fuse (see battery fuse documentation).
7. Switch the Sunny Island on (see Section 10.1, page 124).
8. Activate the user interface of the inverter (see Section 8.1, page 110).
9. Log in as Installer (see Section 8.2, page 112).
10. Start the installation assistant.
11. Select [**Save and next**] for each step up to the step Battery configuration.
12. Select the button [**New battery configuration**].
13. Set the parameter **Type** to the battery type used.
14. Only make the following settings for lead-acid batteries.
 - Set the parameter **Voltage** to the battery voltage.
 - Set the parameter **Nominal capacity** to the C10 nominal capacity of the battery (see Section 9.8.1 "Determining the Battery Capacity", page 122).
15. Select [**Save and next**] until the installation assistant closes.

14.10 Replacing the Micro SD Card

⚠ QUALIFIED PERSON

⚠ DANGER

Danger to life from electric shock due to high voltages

High voltages are present inside the inverter. When the enclosure lid is removed, live components can be touched that can result in death or serious injury due to electric shock.

- Disconnect the inverter from all voltage sources (see Section 13, page 132).
- After switching off the inverter, wait at least 15 minutes before opening the inverter to allow the capacitors to discharge completely.

NOTICE**Damage to the inverter due to electrostatic discharge**

Touching electronic components can cause damage to or destroy the inverter through electrostatic discharge.

- Ground yourself before touching any component.

Requirements on the micro SD card:

- A micro SD card must be used. Other memory cards (e.g. MMC cards) may not be used.
- Data storage in the FAT16/32 file format must be possible.
- Minimum storage capacity: 1 GB
- Maximum storage capacity: 64 GB
- Quality: industry standard

Requirements:

- The micro SD card must be available.
- The inverter must be disconnected from all voltage sources (see Section 13, page 132).

Procedure:

1. Disconnect the inverter from all voltage sources (see Section 13, page 132).
2. Open the inverter (see Section 14.11, page 142).
3. Remove the defective SD memory card.
4. Insert the micro SD card into the slot up to the stop. Do not jam the micro SD card when doing so.
5. Ensure that the micro SD card is correctly plugged in.
6. Close the inverter (see Section 14.11, page 142).
7. Recommission the inverter (see Section 14.12, page 143).

14.11 Opening the Inverter

⚠ QUALIFIED PERSON

If you have to open the inverter enclosure lid for repairs or replacement, proceed as described in the following.

⚠ DANGER**Danger to life from electric shock due to high voltages**

High voltages are present inside the inverter. When the enclosure lid is removed, live components can be touched that can result in death or serious injury due to electric shock.

- Disconnect the inverter from all voltage sources (see Section 13, page 132).
- After switching off the inverter, wait at least 15 minutes before opening the inverter to allow the capacitors to discharge completely.

NOTICE**Damage to seals on the enclosure lids in subfreezing conditions**

If you open the enclosure lid when temperatures are below freezing, the enclosure lid seal could be damaged. This can lead to moisture entering the inverter.

- Only open the enclosure lid if the ambient temperature is not below -5°C
- If a layer of ice has formed on the seal of the lid when temperatures are below freezing, remove it prior to opening the enclosure lid (e.g. by melting the ice with warm air). Observe the applicable safety regulations.

NOTICE**Damage to the inverter due to electrostatic discharge**

Touching electronic components can cause damage to or destroy the inverter through electrostatic discharge.

- Ground yourself before touching any component.

Procedure:

1. To prevent water or dust entering the interior of the inverter, clean and dry the lid prior to removal.
2. On the Sunny Island, remove all screws of the lower enclosure lid using an Allen key (AF 5) and remove the enclosure lid. Retain the screws and conical spring washers for later use.
3. Carefully remove the enclosure lid.
4. Perform the repair or replacement.
5. Replace the enclosure lid with the screws onto the enclosure and hold in place.
6. Attach one conical spring washer to each screw. The grooved side of the conical spring washer must point to the screw head. Tip: The scope of delivery of the Sunny Island inverter includes one additional replacement screw with a conical spring washer.
7. On the Sunny Island, fasten the enclosure lid following the sequence 1 to 6 using an Allen key (AF 5) (torque: 6 Nm). The teeth of the serrated conical spring washer must press into the enclosure lid. This ensures that the enclosure lid is grounded.

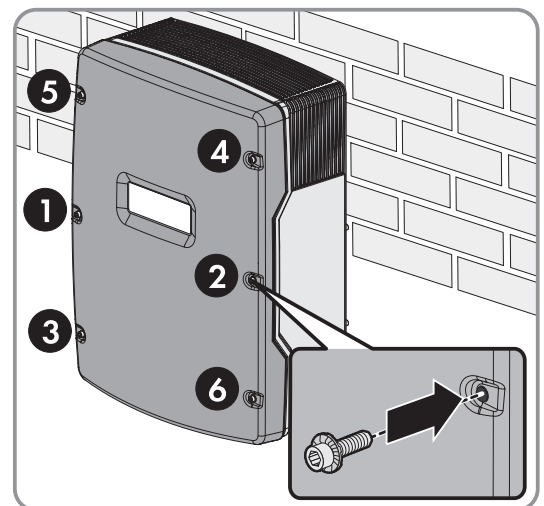

8. Recommission the inverter (see Section 14.12, page 143).

14.12 Recommissioning the Inverter**⚠ QUALIFIED PERSON**

If you have disconnected the inverter from all voltage sources and want to recommission it, proceed as follows.

Requirements:

- All circuit breakers in the AC distribution board must be open.

- All Sunny Island inverters must be connected correctly (see Section 6.7, page 68).
- All Sunny Island inverters must be closed (see Section 6.8, page 72).
- All Sunny Island inverters must be switched off.
- The fuse switch-disconnector of the battery fuse must be closed (see Section 6.9, page 73).

Procedure:

1. Switching on the Sunny Island:

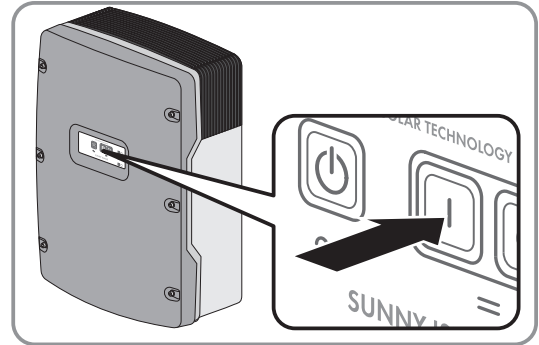

- For systems with one Sunny Island, press the "On" button.
 - For systems with three Sunny Island inverters, press and hold the "On" button on the master until an acoustic signal sounds.
 - For multicluster systems, press and hold the "On" button on each master until an acoustic signal sounds.
2. Establish a connection to the user interface of the inverter (see Section 8.1, page 110).

15 Troubleshooting

15.1 Sunny Island Inverter Behavior Under Fault Conditions

Event messages

Warnings and errors are displayed in the menu **Events** in the user interface until the causes of these warnings and errors are no longer detected by the Sunny Island. Exception: Some errors must be acknowledged via the user interface.

Information is also displayed in the menu **Events** by the Sunny Island (see Section 15.2, page 145).

Autostart

The autostart function allows automatic restarts in the event of malfunctions. If the autostart function fails in the event of a malfunction, the Sunny Island attempts to carry out the next autostart immediately. The number of autostarts is restricted.

When the maximum number of autostarts has been reached, the Sunny Island reacts as follows:

- The Sunny Island waits ten minutes.
- The autostart counter is reset.
- The Sunny Island attempts to perform an autostart.
- When the maximum number of autostarts has been reached, the Sunny Island waits again for ten minutes.

15.2 Event Messages

| Event number | Message, cause and corrective measures |
|--------------|---|
| 104 to 204 | <p>⚠ QUALIFIED PERSON</p> <p>Grid fault</p> <p>The voltage of the generator or the utility grid at the Sunny Island is too high.</p> <p>Corrective measures for a generator:</p> <ul style="list-style-type: none"> • Adjust the thresholds for the generator voltage on the Sunny Island (see Sunny Island technical information "Measured Values and Parameters"). As an aid to this, observe and evaluate the measured values Voltage external power connection phase Lxx during ongoing operation. <p>Adjust the generator voltage and/or generator frequency.</p> <p>Corrective measures in a battery-backup system:</p> <ul style="list-style-type: none"> • Contact the Service (see Section 19, page 189). |
| 301 | <p>⚠ QUALIFIED PERSON</p> <p>Voltage increase protection</p> <p>Voltage increase protection line conductor Lxx</p> <p>Corrective measures:</p> <ul style="list-style-type: none"> • Ensure that the conductor cross-section of the AC cables is correctly sized. |

| Event number | Message, cause and corrective measures |
|--------------|---|
| 405 | <p data-bbox="411 241 694 275">⚠ QUALIFIED PERSON</p> <p data-bbox="387 302 986 336">Ext grid disconnect due to undesired island grid</p> <p data-bbox="387 347 1442 414">Unintended stand-alone grid is present at connection AC2 of the Sunny Island at line conductor L1 / L2 / L3.</p> <p data-bbox="387 432 654 465">Corrective measures:</p> <ul data-bbox="411 477 1412 544" style="list-style-type: none"> • Ensure that the insulated wires at connection AC2 are securely connected and that the conductors in the terminals are free of insulation. <p data-bbox="387 560 853 593">Corrective measures for a generator:</p> <ul data-bbox="411 604 1428 784" style="list-style-type: none"> • Control of the contactor via a Sunny Island inverter multifunction relay. To do so, set the parameter Operating mode of multifunction relay to Automatic generator request. • Set the parameter Sensitivity of generator failure detection to a lower sensitivity level. <p data-bbox="387 801 853 835">Corrective measures for a utility grid:</p> <ul data-bbox="411 846 989 880" style="list-style-type: none"> • Contact the Service (see Section 19, page 189). |
| 504 to 505 | <p data-bbox="411 907 694 940">⚠ QUALIFIED PERSON</p> <p data-bbox="387 963 510 996">Grid fault</p> <p data-bbox="387 1008 1396 1041">The frequency of the generator or the utility grid at the Sunny Island is too low or too high.</p> <p data-bbox="387 1059 853 1093">Corrective measures for a generator:</p> <ul data-bbox="411 1104 1412 1171" style="list-style-type: none"> • The generator may be overloaded. Reduce the total power of the loads by staggering their use over time. <p data-bbox="438 1182 1396 1283">Adjust the thresholds for the generator frequency on the inverter (see Section 7.8.1.3, page 97). As an aid to this, observe and evaluate the measured values Grid frequency of external power connection during ongoing operation.</p> <p data-bbox="438 1299 1013 1332">Adjust the frequency of the external energy source.</p> <p data-bbox="387 1350 853 1384">Corrective measures for a utility grid:</p> <ul data-bbox="411 1395 989 1429" style="list-style-type: none"> • Contact the Service (see Section 19, page 189). |
| 803 | <p data-bbox="411 1444 694 1478">⚠ QUALIFIED PERSON</p> <p data-bbox="387 1500 510 1534">Grid fault</p> <p data-bbox="387 1545 1428 1624">The voltage and/or frequency of the generator or the utility grid is/are outside of the configured range.</p> <p data-bbox="387 1641 853 1675">Corrective measures for a generator:</p> <ul data-bbox="411 1686 1428 1865" style="list-style-type: none"> • Adjust the thresholds for the frequency and/or voltage of the generator on the Sunny Island (see Section 7.8.1, page 96). As an aid to this, observe and evaluate the measured values Voltage external power connection and Grid frequency of external power connection during ongoing operation. • Adjust the generator voltage and/or generator frequency. <p data-bbox="387 1883 853 1917">Corrective measures for a utility grid:</p> <ul data-bbox="411 1928 989 1962" style="list-style-type: none"> • Contact the Service (see Section 19, page 189). |

| Event number | Message, cause and corrective measures |
|--------------|--|
| 1304 | <p>⚠ QUALIFIED PERSON</p> <p>Grid connection installation fault</p> <p>Assignment of the line conductors of the external energy source to the AC2 connections of the Sunny Island does not result in a right-rotating magnetic field.</p> <p>Corrective measures:</p> <ul style="list-style-type: none"> • Ensure that the master is connected to L1, slave 1 is connected to L2, and slave 2 is connected to L3. |
| 1402 | <p>⚠ QUALIFIED PERSON</p> <p>Grid fault</p> <p>The voltage of the generator or the utility grid at the master is outside the configured thresholds (redundant measurement).</p> <p>Corrective measures for a generator:</p> <ul style="list-style-type: none"> • Adjust the thresholds for the voltage of the generator on the Sunny Island (see Section 7.8.1.2, page 97). As an aid to this, observe and evaluate the measured values Voltage external power connection phase Lxx during ongoing operation. • If possible, adjust the generator voltage. <p>Corrective measures for a utility grid:</p> <ul style="list-style-type: none"> • Contact the Service (see Section 19, page 189). |
| 1403 | <p>⚠ QUALIFIED PERSON</p> <p>Grid fault</p> <p>The Sunny Island disconnects from the external energy source because the voltage at connection AC2 is too high or the battery voltage is too low.</p> <p>Corrective measures:</p> <ul style="list-style-type: none"> • Contact the Service (see Section 19, page 189). |
| 1404 | <p>⚠ QUALIFIED PERSON</p> <p>Grid fault</p> <p>The Sunny Island disconnects from the utility grid due to phase conductor failure/overload at terminal AC2.</p> <p>Corrective measures:</p> <ul style="list-style-type: none"> • Reduce the total power of the loads, e.g. by staggering their use over time. • Ensure that there is not a short circuit present at connection AC2. |
| 1405 | <p>⚠ QUALIFIED PERSON</p> <p>Grid fault</p> <p>A short circuit is present at connection AC2 of the Sunny Island at line conductor L1 / L2 / L3.</p> <p>Corrective measures:</p> <ul style="list-style-type: none"> • Eliminate the short circuit. |

| Event number | Message, cause and corrective measures |
|--------------|---|
| 1407 | <p data-bbox="411 241 692 271">⚠ QUALIFIED PERSON</p> <p data-bbox="389 300 512 329">Grid fault</p> <p data-bbox="389 344 1417 412">Disconnection from the utility grid due to non-compliance with the voltage-frequency ratio at line conductor Lxx</p> <p data-bbox="389 427 655 456">Corrective measures:</p> <ul data-bbox="411 472 991 510" style="list-style-type: none"> <li data-bbox="411 472 991 510">• Contact the Service (see Section 19, page 189). |
| 1408 | <p data-bbox="411 533 692 562">⚠ QUALIFIED PERSON</p> <p data-bbox="389 591 512 620">Grid fault</p> <p data-bbox="389 636 1417 703">AC sources in the system are driving the generator. The reverse power in the generator has been exceeded for too long.</p> <p data-bbox="389 719 655 748">Corrective measures:</p> <ul data-bbox="411 763 1417 913" style="list-style-type: none"> <li data-bbox="411 763 1417 831">• Adjust the generator request to the properties of the AC sources in the system and the loads, e.g., for PV inverters, preferably request the generator at night. <li data-bbox="411 846 1417 913">• If the generator can absorb reverse power, adjust the settings for reverse power (see Section 7.8.1.4, page 97). |
| 1409 | <p data-bbox="411 936 692 965">⚠ QUALIFIED PERSON</p> <p data-bbox="389 994 512 1023">Grid fault</p> <p data-bbox="389 1039 1417 1106">The Sunny Island disconnects from the utility grid at line conductor L1 / L2 / L3 due to prohibited feedback at phase L1 / L2 / L3.</p> <p data-bbox="389 1122 655 1151">Corrective measures:</p> <ul data-bbox="411 1167 991 1205" style="list-style-type: none"> <li data-bbox="411 1167 991 1205">• Contact the Service (see Section 19, page 189). |
| 1410 | <p data-bbox="411 1227 692 1256">⚠ QUALIFIED PERSON</p> <p data-bbox="389 1285 512 1314">Grid fault</p> <p data-bbox="389 1330 1417 1397">The feed-in current at line conductor L1 / L2 / L3 is higher than the set maximum value (parameter Maximum current from public grid).</p> <p data-bbox="389 1413 655 1442">Corrective measures:</p> <ul data-bbox="411 1458 991 1496" style="list-style-type: none"> <li data-bbox="411 1458 991 1496">• Contact the Service (see Section 19, page 189). |
| 1411 | <p data-bbox="411 1518 692 1547">⚠ QUALIFIED PERSON</p> <p data-bbox="389 1576 512 1606">Grid fault</p> <p data-bbox="389 1621 1417 1688">External current at L1 / L2 / L3 exceeds the value set for parameter Maximum current from public grid or Rated generator current by 2%.</p> <p data-bbox="389 1704 655 1733">Corrective measures:</p> <ul data-bbox="411 1749 1086 1832" style="list-style-type: none"> <li data-bbox="411 1749 895 1778">• Reduce power consumption of all loads. <li data-bbox="411 1794 1086 1832">• Reduce power output of the AC sources (e.g. PV inverter). |

| Event number | Message, cause and corrective measures |
|--------------|--|
| 1412 | <p>⚠ QUALIFIED PERSON</p> <p>Grid fault</p> <p>The pre-fuse F104.1, F104.2 or F104.3 in the Multicluster-Box is open. A Sunny Island in the main cluster (master / slave 1 / slave 2) detects a supply voltage at ExtVtg and tries to switch to L1 / L2 / L3 in the multicluster system. Because L1 / L2 / L3 is missing due to the open pre-fuse, this results in an anti-islanding error.</p> <p>Corrective measures:</p> <ul style="list-style-type: none"> • Reactivate the pre-fuse. • Check the voltage supply at terminal AC2 of the master in the main cluster. |
| 1413 | <p>⚠ QUALIFIED PERSON</p> <p>Grid fault</p> <p>Phase position of the measured AC voltage at ExtVtg and AC2 does not match at line conductor L1 / L2 / L3.</p> <p>Corrective measures:</p> <ul style="list-style-type: none"> • Ensure that the neutral conductor and line conductor are correctly connected to connection ExtVtg. • Ensure that the neutral conductor and line conductor are correctly connected to connection AC2. • Ensure that connections ExtVtg and AC2 are connected to the same line conductor. |
| 1415 | <p>⚠ QUALIFIED PERSON</p> <p>Grid fault</p> <p>Tie switch does not close.</p> <p>Corrective measures:</p> <ul style="list-style-type: none"> • Ensure that the triggering of the tie switch is correct. • Ensure that the tie switch is correctly wired. • Ensure that the feedback contact is correctly connected. |
| 1416 | <p>⚠ QUALIFIED PERSON</p> <p>Grid fault</p> <p>The Sunny Island system disconnects from the generator or utility grid due to a voltage imbalance between the line conductors.</p> <p>Corrective measures:</p> <ul style="list-style-type: none"> • Eliminate any faults in the installation. |
| 1601 | Automatic generator start due to set criteria, e.g. battery state of charge |
| 1602 | Automatic generator stop due to set criteria, e.g. battery state of charge |
| 1603 | Manual generator start |
| 1604 | Manual generator stop |
| 1605 | Manual error acknowledgment of generator error |

| Event number | Message, cause and corrective measures |
|--------------|--|
| 1606 | Generator requested |
| 1607 | Generator started in current-controlled op |
| 1608 | Generator stopped in current-controlled op |
| 1609 | Network request due to low battery state of charge |
| 1610 | Release of network disconnect due to sufficient battery state of charge |
| 1611 | Grid request due to power limit being exceeded |
| 1612 | With open section switch, AC voltage is applied at phase Lxx |
| 1613 | Manual grid request |
| 1614 | Manual network disconnect release |
| 1615 | <p>⚠ QUALIFIED PERSON</p> <p>Locking of generator due to excessive connect. processes Blocking of generator due to too many interrupted start-ups</p> <p>Corrective measures:</p> <p>A warm-up time Warm-up time of generator that is too short may have been configured and hence the generator is unable to supply valid voltage.</p> <ul style="list-style-type: none"> • Ensure that the generator triggering is functioning, the generator starts, and there is constant and stable generator voltage present at connection AC2. • Ensure that the warm-up time for the generator is set to a sufficient duration (see Section 7.8.3.1, page 99). • To re-enable connection of the generator, acknowledge the generator error (see Section 15.3, page 174). |
| 1616 | <p>⚠ QUALIFIED PERSON</p> <p>Synchronization not executed Synchronization with the generator not successful.</p> <ul style="list-style-type: none"> • Ensure that the generator can be started. The fuel level may be too low. • Ensure that a constant and stable voltage is present at connection AC2. • Ensure that the thresholds for the generator voltage are correctly configured (see Section 7.8.1.2, page 97). |
| 1701 | Automatic frequency control intervenes |
| 1702 | Automatic frequency control ends |

| Event number | Message, cause and corrective measures |
|--------------|--|
| 1704 | <p>⚠ QUALIFIED PERSON</p> <p>Generator operation not possible Generator operation not possible</p> <p>Corrective measures:</p> <ul style="list-style-type: none">• Reset the off-grid system. For this, disconnect all loads, AC sources, generator and DC sources. Open the battery fuse load-break switch. Wait ten minutes and restart the off-grid system. Wait until all AC sources are feeding into the stand-alone grid and all loads are connected before connecting the generator.• Contact the Service (see Section 19, page 189). |
| 1705 | <p>No valid network voltage for requested network op. Voltage of the external energy source is not within the valid thresholds for connection.</p> <p>Corrective measures:</p> <ul style="list-style-type: none">• Acknowledge the error (see Section 15.3, page 174).• Contact the Service (see Section 19, page 189). |
| 1706 | <p>⚠ QUALIFIED PERSON</p> <p>System failure A contactor in the Multicluster-Box is not functioning correctly.</p> <p>Corrective measures:</p> <ul style="list-style-type: none">• Reset the off-grid system. For this, disconnect the off-grid system and restart.• Start the installation assistant and reconfigure multicluster operation• Contact the Service (see Section 19, page 189). |
| 1707 | <p>⚠ QUALIFIED PERSON</p> <p>Stand-alone grid An overvoltage has occurred at connection AC1 of the Sunny Island.</p> <p>Corrective measures:</p> <ul style="list-style-type: none">• Ensure that the Sunny Island is functional. For this, disconnect all AC sources and loads from the Sunny Island and restart the Sunny Island.• Find the cause of the overvoltage through measurement and step-by-step connection of the AC sources and loads. |
| 1708 | <p>⚠ QUALIFIED PERSON</p> <p>Stand-alone grid An overfrequency has occurred at connection AC1 of the Sunny Island.</p> <p>Corrective measures:</p> <ul style="list-style-type: none">• Ensure that the Sunny Island is functional. For this, disconnect all AC sources and loads from the Sunny Island and restart the Sunny Island.• Find the cause of the overvoltage through measurement and step-by-step connection of the AC sources and loads. |

| Event number | Message, cause and corrective measures |
|--------------|--|
| 1709 | <p data-bbox="389 241 695 277">⚠ QUALIFIED PERSON</p> <p data-bbox="389 300 600 336">Stand-alone grid</p> <p data-bbox="389 344 1203 380">An underfrequency has occurred at connection AC1 of the Sunny Island.</p> <p data-bbox="389 389 655 425">Corrective measures:</p> <ul data-bbox="411 434 1426 591" style="list-style-type: none"> <li data-bbox="411 434 1426 510">• Ensure that the Sunny Island is functional. For this, disconnect all AC sources and loads from the Sunny Island and restart the Sunny Island. <li data-bbox="411 519 1426 591">• Find the cause of the underfrequency through measurement and step-by-step connection of the AC sources and loads. |
| 1710 | <p data-bbox="389 616 695 651">⚠ QUALIFIED PERSON</p> <p data-bbox="389 674 600 710">Stand-alone grid</p> <p data-bbox="389 719 1369 754">Voltage at terminal AC1 of the Sunny Island is too low due to AC sources in the system.</p> <p data-bbox="389 763 655 799">Corrective measures:</p> <ul data-bbox="411 808 1426 965" style="list-style-type: none"> <li data-bbox="411 808 1426 884">• Ensure that the Sunny Island is functional. For this, disconnect all AC sources and loads from the Sunny Island and restart the Sunny Island. <li data-bbox="411 893 1426 965">• Find the cause of the undervoltage through measurement and step-by-step connection of the AC sources and loads. |
| 1711 | <p data-bbox="389 990 695 1025">⚠ QUALIFIED PERSON</p> <p data-bbox="389 1048 600 1084">Stand-alone grid</p> <p data-bbox="389 1093 1177 1128">The Sunny Island has measured an undesired voltage at terminal AC1.</p> <p data-bbox="389 1137 655 1173">Corrective measures:</p> <p data-bbox="389 1182 1075 1218">A bypass switch may have bridged the internal transfer relay.</p> <ul data-bbox="411 1227 1318 1263" style="list-style-type: none"> <li data-bbox="411 1227 1318 1263">• Ensure that the bypass switch is in the position for operation with Sunny Island. <p data-bbox="389 1272 1378 1339">An external energy source (e.g., generator) may have been connected to the connection AC1.</p> <ul data-bbox="411 1348 1378 1415" style="list-style-type: none"> <li data-bbox="411 1348 1378 1415">• Disconnect external energy source from connection AC1 and connect to connection AC2. |
| 1712 | <p data-bbox="389 1451 695 1487">⚠ QUALIFIED PERSON</p> <p data-bbox="389 1509 600 1545">Stand-alone grid</p> <p data-bbox="389 1554 1299 1590">When the tie switch is open, AC voltage is present at line conductor L1 / L2 / L3.</p> <p data-bbox="389 1599 655 1635">Corrective measures:</p> <ul data-bbox="411 1644 1015 1724" style="list-style-type: none"> <li data-bbox="411 1644 1015 1680">• Ensure that the triggering of the tie switch is correct. <li data-bbox="411 1688 919 1724">• Ensure that the tie switch is correctly wired. |

| Event number | Message, cause and corrective measures |
|--------------|---|
| 1713 | <p>⚠ QUALIFIED PERSON</p> <p>System failure</p> <p>One line conductor of a Sunny Island is missing.</p> <p>Corrective measures:</p> <ul style="list-style-type: none"> • Ensure that all circuit breakers of the Sunny Island inverters in the Multicluster-Box are closed. • Search for the missing line conductor and eliminate the error. To identify the missing line conductor, measure the AC voltage between each line conductor and between the line conductors and the neutral conductors with the loads connected. If an AC voltage deviates from the nominal voltage by $\pm 10\%$, the corresponding line conductor is missing. • Reset the off-grid system. For this, disconnect the off-grid system and restart. |
| 3803 | <p>DC overcurrent</p> <p>Too much current is flowing through the DC connection of a Sunny Island.</p> <p>Corrective measures:</p> <ul style="list-style-type: none"> • Reduce the power of the loads. |
| 6120 to 6135 | <p>Interference device</p> <p>OCU watchdog has triggered (an error has occurred in the program sequence).</p> <p>Corrective measures:</p> <ul style="list-style-type: none"> • Contact the Service (see Section 19, page 189). |
| 6316 | <p>⚠ QUALIFIED PERSON</p> <p>Interference device</p> <p>Fault of voltage/current measurement at ext. measure point of box to AC sub-distribution (Multicluster-Box) phase L1 / L2 / L3.</p> <p>Corrective measures:</p> <ul style="list-style-type: none"> • Ensure that the control and measuring cable between the Multicluster-Box and the corresponding Sunny Island of the main cluster is correctly inserted. When doing so, observe the correct sequence of the Multicluster-Box connections to the Sunny Island inverters (see the Multicluster-Box documentation). |
| 6463 | <p>Interference device</p> <p>Corrective measures:</p> <ul style="list-style-type: none"> • Contact the Service (see Section 19, page 189). |
| 6465 | <p>Interference device</p> <p>Processor voltage in the device at L1 / L2 / L3 is incorrect.</p> <p>Corrective measures:</p> <ul style="list-style-type: none"> • Contact the Service (see Section 19, page 189). |

| Event number | Message, cause and corrective measures |
|--------------|---|
| 6466 | <p>System failure</p> <p>15 V voltage supply or 24 V voltage supply in the Multicluster Box is defective.</p> <p>Corrective measures:</p> <ul style="list-style-type: none"> • Contact the Service (see Section 19, page 189). |
| 6502 to 6514 | <p>⚠ QUALIFIED PERSON</p> <p>Overtemperature</p> <p>Temperature of the transformer or the heat sink in the Sunny Island is too high (due to overload or ambient temperature).</p> <p>Corrective measures:</p> <ul style="list-style-type: none"> • Ensure that the Sunny Island is functional. For this, disconnect all AC sources and loads from the Sunny Island and restart the Sunny Island. • Reduce the total power of the loads, e.g. by staggering their use over time. • Clean the fans (see Section 14.4, page 134). |
| 6609 | <p>⚠ QUALIFIED PERSON</p> <p>Overload</p> <p>Battery voltage is too low.</p> <p>Corrective measures:</p> <ul style="list-style-type: none"> • Charge the battery in emergency charge operation or using an external battery charger (see Section 14.7, page 137). • Ensure that DC loads are shed via a load-shedding contactor when the battery state of charge is low. |
| 6610 | <p>⚠ QUALIFIED PERSON</p> <p>Overload</p> <p>Battery voltage is temporarily too high.</p> <p>Corrective measures:</p> <ul style="list-style-type: none"> • Ensure that all DC sources are correctly configured. • Ensure that all SMA inverters are configured to the country data set for stand-alone grid operation. |
| 6612 | <p>⚠ QUALIFIED PERSON</p> <p>Overload</p> <p>Excessive current has been applied to the internal transfer relay of a Sunny Island.</p> <p>Corrective measures:</p> <ul style="list-style-type: none"> • Reduce the total power of the loads, e.g. by staggering their use over time. • Connect the loads with very high power directly to the generator whenever possible or connect the utility grid. Ensure that the generator is not overloaded. • In off-grid systems, ensure that the country data sets of the SMA inverters are set to stand-alone mode. |

| Event number | Message, cause and corrective measures |
|--------------|--|
| 6613 | <p data-bbox="443 241 730 280">⚠ QUALIFIED PERSON</p> <p data-bbox="427 302 550 331">Overload</p> <p data-bbox="427 347 1023 376">The power of the loads is too high for a Sunny Island.</p> <p data-bbox="427 392 694 421">Corrective measures:</p> <ul data-bbox="443 436 1476 757" style="list-style-type: none"> <li data-bbox="443 436 1364 510">• Ensure that the inverter is functional. Clean the fans and restart the inverter (see Section 10.2, page 124). <li data-bbox="443 521 1476 595">• Ensure that there are no short circuits in the system and that the power of the loads is not greater than the power of the Sunny Island inverter. <li data-bbox="443 607 1476 680">• Use a star delta electronic circuit to start three-phase loads with a high start-up electricity demand (e.g. motors). <li data-bbox="443 692 1428 757">• Connect the loads with very high power directly to the generator whenever possible. Ensure that the generator is not overloaded. |
| 6614 | <p data-bbox="427 779 550 808">Overload</p> <p data-bbox="427 824 1305 853">The device at L1 / L2 / L3 has been loaded over its five-minute rated capacity.</p> <p data-bbox="427 869 694 898">Corrective measures:</p> <ul data-bbox="443 913 831 958" style="list-style-type: none"> <li data-bbox="443 913 831 958">• Reduce the power of the loads. |
| 6615 | <p data-bbox="427 981 550 1010">Overload</p> <p data-bbox="427 1025 1305 1055">The device at L1 / L2 / L3 has been loaded over its 30 minute rated capacity.</p> <p data-bbox="427 1070 694 1099">Corrective measures:</p> <ul data-bbox="443 1115 831 1160" style="list-style-type: none"> <li data-bbox="443 1115 831 1160">• Reduce the power of the loads. |
| 6616 | <p data-bbox="427 1182 550 1211">Overload</p> <p data-bbox="427 1227 1305 1256">The device at L1 / L2 / L3 has been loaded over its rated short-term capacity.</p> <p data-bbox="427 1272 694 1301">Corrective measures:</p> <ul data-bbox="443 1317 831 1361" style="list-style-type: none"> <li data-bbox="443 1317 831 1361">• Reduce the power of the loads. |
| 7002 to 7004 | <p data-bbox="427 1384 831 1413">Sensor fault fan permanently on</p> <p data-bbox="427 1429 1476 1480">There is a short circuit or cable break at a temperature sensor of the device at line conductor L1 / L2 / L3.</p> <p data-bbox="427 1496 694 1525">Corrective measures:</p> <ul data-bbox="443 1541 1023 1585" style="list-style-type: none"> <li data-bbox="443 1541 1023 1585">• Contact the Service (see Section 19, page 189). |
| 7010 | <p data-bbox="443 1608 730 1646">⚠ QUALIFIED PERSON</p> <p data-bbox="427 1659 1278 1688">Short circuit battery temp. sensor > Check sensor status and function</p> <p data-bbox="427 1704 903 1733">Short circuit on battery temperature sensor</p> <p data-bbox="427 1749 694 1778">Corrective measures:</p> <ul data-bbox="443 1794 1428 1908" style="list-style-type: none"> <li data-bbox="443 1794 1428 1868">• Ensure that the battery temperature sensor is correctly connected (see Section 6.5.8, page 47). <li data-bbox="443 1879 1023 1908">• Contact the Service (see Section 19, page 189). |

| Event number | Message, cause and corrective measures |
|--------------|---|
| 7011 | <p>⚠ QUALIFIED PERSON</p> <p>Cable break battery temp. sensor > Check sensor status and function Cable break on battery temperature sensor</p> <p>Corrective measures:</p> <ul style="list-style-type: none"> • Ensure that the battery temperature sensor is correctly connected (see Section 6.5.8, page 47). • Contact the Service (see Section 19, page 189). |
| 7101 | <p>⚠ QUALIFIED PERSON</p> <p>SD card defective Micro SD card in the inverter is faulty.</p> <p>Corrective measures:</p> <ul style="list-style-type: none"> • Replace the micro SD card (see Section 14.10, page 141). |
| 7102 | <p>Parameter file not found or defective Parameter file not found / defective. The parameter file could not be found or is defective. The update failed.</p> <p>Corrective measures:</p> <ul style="list-style-type: none"> • Copy the parameter file to the correct folder again. |
| 27103 | <p>Set parameter The parameter change has been adopted.</p> |
| 27104 | <p>Parameters set successfully The parameter changes were successfully adopted.</p> |
| 7105 | <p>Param. setting failed Parameters could not be set using the memory card.</p> <p>Corrective measures:</p> <ul style="list-style-type: none"> • Make sure thresholds of the parameters are complied with. • Change the parameter again. • For grid-relevant parameter: Ensure that the SMA Grid Guard code is available. |
| 7106 | <p>Update file defect. The update file is defective. The update failed.</p> <p>Corrective measures:</p> <ul style="list-style-type: none"> • Repeat firmware update (see Section 11.4, page 127). |
| 27107 | <p>Update file OK The update file is suitable for this inverter and its components and is fully available for the next update step.</p> |
| 27108 | <p>SD card is read The inverter is currently reading the SD memory card.</p> |

| Event number | Message, cause and corrective measures |
|--------------|--|
| 27109 | <p>No new update SDcard</p> <p>The micro SD card contains an update file that has already been used.</p> |
| 7110 | <p>No update file found</p> |
| 7112 | <p>Update file successfully copied</p> <p>Update file was copied successfully to the inverter's internal memory.</p> |
| 7113 | <p>The memory card is full or write-protected</p> |
| 27301 | <p>Update communication</p> <p>The inverter is updating the communication component.</p> |
| 27302 | <p>Update main CPU</p> <p>The inverter is updating the inverter component.</p> |
| 7303 | <p>Update main CPU failed</p> <p>The cause must be determined by the Service.</p> <p>Corrective measures:</p> <ul style="list-style-type: none"> • Contact the Service (see Section 19, page 189). |
| 27312 | <p>Update completed</p> <p>The inverter has successfully completed the update.</p> |
| 7320 | <p>The device with serial number [xx] was successfully updated to firmware version [xxx].</p> <p>The firmware update was completed successfully.</p> |
| 7329 | <p>Condition test successful</p> <p>The testing of the update conditions was not successful. The firmware update package is not suitable for this inverter.</p> |
| 7330 | <p>⚠ QUALIFIED PERSON</p> <p>Condition test failed</p> <p>The conditions of the update file used for the inverter settings are not fulfilled.</p> <p>Corrective measures:</p> <ul style="list-style-type: none"> • Retry update. • Ensure that the selected update file is suitable for this inverter. • If this message is displayed again, contact the Service (see Section 19, page 189). |
| 7331 | <p>Update transport started</p> <p>Update file is being copied.</p> |
| 7332 | <p>Update transport successful</p> <p>Update file was copied successfully to the inverter's internal memory.</p> |

| Event number | Message, cause and corrective measures |
|--------------|--|
| 7333 | <p>⚠ QUALIFIED PERSON</p> <p>Update transport failed</p> <p>Update file could not be copied to the inverter's internal memory. In the event of connection with the inverter via WLAN, a poor connection quality can be the cause.</p> <p>Corrective measures</p> <ul style="list-style-type: none"> • Establish connection with the inverter via Ethernet. • Retry update. • If this message is displayed again, contact the Service (see Section 19, page 189). |
| 7341 | <p>Update Bootloader</p> <p>The inverter is performing a bootloader update.</p> |
| 7342 | <p>⚠ QUALIFIED PERSON</p> <p>Update Bootloader failed</p> <p>The bootloader update failed.</p> <p>Corrective measures:</p> <ul style="list-style-type: none"> • Retry update. • If this message is displayed again, contact the Service (see Section 19, page 189). |
| 7345 | <p>Master starts firmware update of cluster</p> <p>The firmware update for slave 1 and slave 2 has been started.</p> |
| 7347 | <p>⚠ QUALIFIED PERSON</p> <p>Incompatible file</p> <p>The configuration file is not suitable for this inverter.</p> <p>Corrective measures:</p> <ul style="list-style-type: none"> • Ensure that the selected configuration file is suitable for this inverter. • Retry import. |
| 7348 | <p>⚠ QUALIFIED PERSON</p> <p>Incorrect file format</p> <p>The configuration file is not of the required format or is damaged.</p> <p>Corrective measures:</p> <ul style="list-style-type: none"> • Ensure that the selected configuration file is of the required format and is not damaged. • Retry import. |
| 7349 | <p>Incorrect login rights for configuration file</p> <p>The user group logged in does not have the user rights necessary to be able to import a configuration.</p> <p>Corrective measures:</p> <ul style="list-style-type: none"> • Log in as Installer. • Import configuration file again. |

| Event number | Message, cause and corrective measures |
|--------------|--|
| 7350 | <p>Transfer of a configuration file has started</p> <p>The configuration file is being transferred.</p> |
| 7351 | <p>Update WLAN</p> <p>The inverter is updating the WLAN module.</p> |
| 7352 | <p>Update of WLAN not successful</p> <p>The update of the WLAN module failed.</p> <p>Corrective measures:</p> <ul style="list-style-type: none"> • Retry update. • If this message is displayed again, contact the Service (see Section 19, page 189). |
| 7353 | <p>Update time zone database</p> <p>The inverter is updating the time zone database.</p> |
| 7354 | <p>⚠ QUALIFIED PERSON</p> <p>Update of time zone database not successful</p> <p>The update of the time zone database failed.</p> <p>Corrective measures:</p> <ul style="list-style-type: none"> • Retry update. • If this message is displayed again, contact the Service (see Section 19, page 189). |
| 7355 | <p>Update WebUI</p> <p>The inverter is updating the inverter user interface.</p> |
| 7356 | <p>⚠ QUALIFIED PERSON</p> <p>Update of the WebUI not successful</p> <p>The update of the inverter user interface failed.</p> <p>Corrective measures:</p> <ul style="list-style-type: none"> • Retry update. • If this message is displayed again, contact the Service (see Section 19, page 189). |
| 7601 | <p>⚠ QUALIFIED PERSON</p> <p>Communication disturbed > Communication fault IPC</p> <p>There is an error in the inverter.</p> <p>Corrective measures:</p> <ul style="list-style-type: none"> • Contact the Service (see Section 19, page 189). |

| Event number | Message, cause and corrective measures |
|--------------|--|
| 7602 | <p>⚠ QUALIFIED PERSON</p> <p>Communication disturbed Device-internal CAN communication is missing in the device at L1 / L2 / L3.</p> <p>Corrective measures:</p> <ul style="list-style-type: none"> • Ensure that the terminators in the communication bus are attached. • Ensure that undamaged CAT5e cables are used for communication and that the cables are plugged in correctly. • Contact the Service (see Section 19, page 189). |
| 7608 | <p>⚠ QUALIFIED PERSON</p> <p>Communication disturbed Communication from the master to slave 1 or slave 2 is interrupted.</p> <p>Corrective measures:</p> <ul style="list-style-type: none"> • Ensure that undamaged CAT5e cables are used for communication and that the cables are plugged in correctly. • Ensure that the communication bus is equipped with a terminator at both ends. |
| 7609 | <p>⚠ QUALIFIED PERSON</p> <p>Communication disturbed Communication with an energy meter is faulty.</p> <p>Corrective measures:</p> <ul style="list-style-type: none"> • Ensure that the optical probe is correctly installed and connected. |
| 7611 | <p>⚠ QUALIFIED PERSON</p> <p>Communication disturbed A protocol that is not supported has been recognized on one energy meter.</p> <p>Corrective measures:</p> <ul style="list-style-type: none"> • Contact the Service (see Section 19, page 189). |
| 7613 | <p>⚠ QUALIFIED PERSON</p> <p>CAN communication with energy meter is faulty. Communication with an energy meter is faulty.</p> <p>Corrective measures:</p> <ul style="list-style-type: none"> • Ensure that the data cables are correctly installed. |
| 7616 | <p>⚠ QUALIFIED PERSON</p> <p>Communication disturbed Device-internal communication of the device at L1 / L2 / L3 is disturbed.</p> <p>Corrective measures:</p> <ul style="list-style-type: none"> • Contact the Service (see Section 19, page 189). |

| Event number | Message, cause and corrective measures |
|--------------|--|
| 7617 | <p data-bbox="443 241 730 280">⚠ QUALIFIED PERSON</p> <p data-bbox="427 302 948 336">Communication with MC-BOX interrupted</p> <p data-bbox="427 347 999 380">Communication with Multicluster Box is interrupted.</p> <p data-bbox="427 392 692 425">Corrective measures:</p> <ul data-bbox="448 436 1453 555" style="list-style-type: none"> <li data-bbox="448 436 1453 510">• Ensure that undamaged CAT5e cables are used for communication and that the cables are plugged in correctly. <li data-bbox="448 521 1353 555">• Ensure that the communication bus is equipped with a terminator at both ends. |
| 7618 | <p data-bbox="443 577 730 616">⚠ QUALIFIED PERSON</p> <p data-bbox="427 638 751 672">Communication disturbed</p> <p data-bbox="427 683 1453 757">CAN communication within the cluster is faulty. Device-internal communication pulse is missing on at least one device.</p> <p data-bbox="427 768 692 801">Corrective measures:</p> <ul data-bbox="448 813 1453 925" style="list-style-type: none"> <li data-bbox="448 813 1453 887">• Ensure that undamaged CAT5e cables are used for communication and that the cables are plugged in correctly. <li data-bbox="448 898 1353 925">• Ensure that the communication bus is equipped with a terminator at both ends. |
| 7619 | <p data-bbox="427 947 884 981">Communication fault with meter unit</p> <p data-bbox="427 992 1099 1025">The inverter is not receiving any data from the energy meter.</p> <p data-bbox="427 1037 692 1070">Corrective measures:</p> <ul data-bbox="448 1081 1453 1205" style="list-style-type: none"> <li data-bbox="448 1081 1453 1155">• Ensure that the energy meter is correctly integrated into the same network as the inverter (see energy meter manual). <li data-bbox="448 1167 1422 1205">• Establish connection between the inverter and the DHCP server (router) via Ethernet. |
| 7620 | <p data-bbox="427 1227 1016 1261">Communication with mains power meter faulty</p> <p data-bbox="427 1272 1099 1305">The inverter is not receiving any data from the energy meter.</p> <p data-bbox="427 1317 692 1350">Corrective measures:</p> <ul data-bbox="448 1361 1453 1485" style="list-style-type: none"> <li data-bbox="448 1361 1453 1435">• Ensure that the energy meter is correctly integrated into the same network as the inverter (see energy meter manual). <li data-bbox="448 1447 1422 1485">• Establish connection between the inverter and the DHCP server (router) via Ethernet. |
| 7716 | <p data-bbox="443 1507 730 1545">⚠ QUALIFIED PERSON</p> <p data-bbox="427 1556 791 1590">Section switch does not open</p> <p data-bbox="427 1601 711 1635">Tie switch does not open.</p> <p data-bbox="427 1646 692 1680">Corrective measures:</p> <ul data-bbox="448 1691 1102 1832" style="list-style-type: none"> <li data-bbox="448 1691 1054 1724">• Ensure that the triggering of the tie switch is correct. <li data-bbox="448 1736 959 1769">• Ensure that the tie switch is correctly wired. <li data-bbox="448 1780 1102 1832">• Ensure that the feedback contact is correctly connected. |
| 7717 | <p data-bbox="427 1854 668 1888">Interference device</p> <p data-bbox="427 1899 1198 1933">Neutral conductor relay of the device at L1 / L2 / L3 does not open.</p> <p data-bbox="427 1944 692 1977">Corrective measures:</p> <ul data-bbox="448 1989 1027 2020" style="list-style-type: none"> <li data-bbox="448 1989 1027 2020">• Contact the Service (see Section 19, page 189). |

| Event number | Message, cause and corrective measures |
|--------------|---|
| 7718 | <p>⚠ QUALIFIED PERSON</p> <p>Interference device</p> <p>Transfer relay does not open at line conductor L1 / L2 / L3. A bypass switch may have bridged the internal transfer relay.</p> <ul style="list-style-type: none"> • Ensure that the bypass switch is in the position for operation with Sunny Island. • Ensure that the connections AC1 and AC2 are not bridged. |
| 7719 | <p>Plausibility check MC-BOX failed</p> <p>Plausibility check on the contactors in the Multicluster-Box has failed.</p> <p>Corrective measures:</p> <ul style="list-style-type: none"> • Contact the Service (see Section 19, page 189). |
| 8003 | <p>⚠ QUALIFIED PERSON</p> <p>Derating occurred</p> <p>The inverter at L1 / L2 / L3 reduces the battery charging current due to overheating.</p> <p>Corrective measures:</p> <ul style="list-style-type: none"> • Reduce the total power of the loads, e.g. by staggering their use over time. • Clean the fan (see Section 14.4, page 134). • If the inverter reduces its power often, increase the power (install a more powerful device type or more inverters of the same type). |
| 8101 to 8104 | <p>Communication disturbed</p> <p>The cause must be determined by the Service.</p> <p>Corrective measures:</p> <ul style="list-style-type: none"> • Contact the Service (see Section 19, page 189). |
| 8609 | <p>⚠ QUALIFIED PERSON</p> <p>A slave has a fault status, cluster is stopped</p> <p>A slave has a fault status, cluster is stopped.</p> <p>Corrective measures:</p> <ul style="list-style-type: none"> • Read off the pending and logged warnings and errors and eliminate the causes. • Contact the Service (see Section 19, page 189). |
| 8610 to 8611 | <p>⚠ QUALIFIED PERSON</p> <p>Error in the cluster configuration</p> <p>The addresses of the slaves in the cluster are incorrect.</p> <p>Corrective measures:</p> <ul style="list-style-type: none"> • Change the addresses of the slaves in the cluster (see Section 14.8, page 139) |

| Event number | Message, cause and corrective measures |
|--------------|--|
| 8612 | <p data-bbox="443 241 730 280">⚠ QUALIFIED PERSON</p> <p data-bbox="427 302 986 340">No message from cluster master (only slave)</p> <p data-bbox="427 347 911 385">Communication to the master is interrupted.</p> <p data-bbox="427 392 692 430">Corrective measures:</p> <ul data-bbox="443 436 1453 555" style="list-style-type: none"> <li data-bbox="443 436 1453 510">• Ensure that undamaged CAT5e cables are used for communication and that the cables are plugged in correctly. <li data-bbox="443 517 1353 555">• Ensure that the communication bus is equipped with a terminator at both ends. |
| 8613 | <p data-bbox="443 577 730 616">⚠ QUALIFIED PERSON</p> <p data-bbox="427 638 660 676">Cluster incomplete</p> <p data-bbox="427 683 1142 721">Voltage of the main cluster cannot be measured at L1 / L2 / L3.</p> <p data-bbox="427 728 686 766">Corrective measures</p> <ul data-bbox="443 772 1453 891" style="list-style-type: none"> <li data-bbox="443 772 1453 846">• Ensure that all circuit breakers of the Sunny Island inverters in the Multicluster-Box are closed. <li data-bbox="443 853 1187 891">• Ensure that the cabling at connection AC1 is correctly installed. |
| 8615 | <p data-bbox="443 913 730 952">⚠ QUALIFIED PERSON</p> <p data-bbox="427 974 1118 1012">Box encoding does not correspond to software settings</p> <p data-bbox="427 1019 1453 1093">Box coding conflicts with software settings: Configuration of the Sunny Island inverters does not match the Multicluster-Box.</p> <p data-bbox="427 1099 692 1137">Corrective measures:</p> <ul data-bbox="443 1144 1453 1317" style="list-style-type: none"> <li data-bbox="443 1144 1453 1218">• Check whether the value set for parameter Type of AC subdistribution matches the connected Multicluster-Box. <li data-bbox="443 1225 1453 1263">• If the value does not match, restart the installation assistant (see Section 9.1, page 118). <li data-bbox="443 1270 1027 1308">• Contact the Service (see Section 19, page 189). |
| 8616 | <p data-bbox="443 1339 730 1377">⚠ QUALIFIED PERSON</p> <p data-bbox="427 1400 660 1438">Cluster incomplete</p> <p data-bbox="427 1444 1453 1518">The voltage supply of contactor Q10 / Q110 has failed due to a short circuit in the stand-alone grid.</p> <p data-bbox="427 1525 692 1563">Corrective measures:</p> <ul data-bbox="443 1570 762 1608" style="list-style-type: none"> <li data-bbox="443 1570 762 1608">• Eliminate the short circuit. |
| 8617 | <p data-bbox="443 1630 730 1668">⚠ QUALIFIED PERSON</p> <p data-bbox="427 1691 1430 1765">Extension cluster has a country data set configured that is different to that of the main cluster</p> <p data-bbox="427 1771 1453 1845">At least in one extension cluster, the Sunny Islands are set to another country standard than the Sunny Islands in the main cluster.</p> <p data-bbox="427 1852 692 1890">Corrective measures:</p> <ul data-bbox="443 1897 1453 1957" style="list-style-type: none"> <li data-bbox="443 1897 1453 1957">• Set the same country standard (parameter Country standard set) in all Sunny Island inverters in the main cluster and in the extension cluster. |

| Event number | Message, cause and corrective measures |
|--------------|---|
| 8618 to 8619 | <p>System failure</p> <p>Tie contactor or tie switch does not open.</p> <ul style="list-style-type: none"> • Contact the Service (see Section 19, page 189). |
| 8620 | <p>System failure</p> <p>At least one extension cluster has another firmware version than the main cluster.</p> <ul style="list-style-type: none"> • Update the firmware (see Section 11.4, page 127). |
| 8706 | System control: Setpoint spec. activated |
| 8707 | System control: Setpoint spec. deactivated |
| 8716 | Inverter switches to energy saving mode because battery range reached |
| 29001 | Grid Guard code valid |
| 9002 | <p>SMA Grid Guard code invalid</p> <p>The SMA Grid Guard code entered is incorrect. The operating parameters are still protected and cannot be changed.</p> <p>Corrective measures:</p> <ul style="list-style-type: none"> • Enter the correct SMA Grid Guard code. |
| 9003 | <p>Grid parameter locked</p> <p>Changes to the grid parameters are now blocked. In order to be able to make changes to the grid parameters, from now on you must log in using the SMA Grid Guard code.</p> |
| 29004 | Grid parameters unchanged |
| 9301 | Reset battery management due to new battery |
| 9308 | <p>⚠ QUALIFIED PERSON</p> <p>Battery fault</p> <p>The timeout monitoring system of the battery management has triggered</p> <p>Corrective measures:</p> <ul style="list-style-type: none"> • Ensure that the data cable of the external lithium-ion battery is connected correctly. • Ensure that the terminators of the CAN bus in the communication bus are attached. |
| 9313 | <p>Battery fault</p> <p>The lower limit of the temperature range approved by the battery manufacturer has been exceeded.</p> <p>Corrective measures:</p> <ul style="list-style-type: none"> • Make sure that the ambient conditions of the battery manufacturer are complied with. |
| 9314 | <p>Battery fault</p> <p>The upper limit of the temperature range approved by the battery manufacturer has been exceeded.</p> <p>Corrective measures:</p> <ul style="list-style-type: none"> • Make sure that the ambient conditions of the battery manufacturer are complied with. |

| Event number | Message, cause and corrective measures |
|--------------|--|
| 9318 | Emergency charge |
| 9319 | Status change to battery float charge |
| 9320 | Status change to battery boost charge |
| 9321 | Status change to battery full charge |
| 9322 | <p>20 percent calibration being executed</p> <p>In the event that the Sunny Island detects an unexpectedly sharp battery voltage drop during electric discharge, resulting in a lower battery voltage for the given discharging current than expected at a certain state of charge, a recalibration of the state of charge to 20% will be performed. Frequent state of charge recalibrations to 20% may be caused by poor battery maintenance, aged batteries, or installation errors (see technical information "Battery Management").</p> |
| 9324 | <p>Battery fault</p> <p>Current battery capacity (SOH) is below 70%.</p> <p>Corrective measures:</p> <ul style="list-style-type: none"> • Verify the plausibility of the error message. • Replace the battery if necessary. |
| 9325 | <p>⚠ QUALIFIED PERSON</p> <p>Battery fault</p> <p>A 20% recalibration of the battery state of charge has been performed with a jump of more than 10%.</p> <p>Corrective measures:</p> <ul style="list-style-type: none"> • Check the battery. |
| 9326 | <p>⚠ QUALIFIED PERSON</p> <p>Battery fault</p> <p>Battery protection mode is active.</p> <p>Corrective measures:</p> <ul style="list-style-type: none"> • Disconnect the loads, start the generator, start the Sunny Island and charge the battery. |
| 9331 | <p>⚠ QUALIFIED PERSON</p> <p>Battery fault</p> <p>Battery voltage in the Sunny Island at L1 / L2 / L3 is above the permissible measurement range.</p> <p>Corrective measures:</p> <ul style="list-style-type: none"> • Check whether the value set for the parameter Battery voltage is above 65.0 V. If the value is above 65.0 V, check the settings of the DC sources and ensure that the battery capacity is sufficient. Observe the technical data for the battery at the DC connection. • Ensure that the DC sources are correctly connected and configured. • For off-grid systems: ensure that all SMA inverters are configured to the country data set for stand-alone mode. |

| Event number | Message, cause and corrective measures |
|--------------|--|
| 9332 | <p>Battery fault</p> <p>External battery management has been detected but not configured.</p> <p>Corrective measures:</p> <ul style="list-style-type: none"> • Start the installation assistant and configure a new system with external energy management (e.g., system with lithium-ion battery). |
| 9333 | <p>⚠ QUALIFIED PERSON</p> <p>Battery fault</p> <p>Measured battery voltage in the Sunny Island at L1 / L2 / L3 is below the permissible measurement range. The usable battery capacity may be too small, e.g., due to aging.</p> <p>Corrective measures:</p> <ul style="list-style-type: none"> • Charge the battery. • Ensure that all battery cells are functional. |
| 9341 | <p>Status change to battery equalization charge</p> |
| 9362 | <p>⚠ QUALIFIED PERSON</p> <p>Battery fault</p> <p>The deep discharge protection range BatResSoc or the deep discharge protection range before disconnection ProResSOC has been reached.</p> <p>A fuse may have tripped at the grid-connection point.</p> <p>Corrective measures:</p> <ul style="list-style-type: none"> • Activate the fuse. • Replace the fuse if necessary. <p>The utility grid may not work within the set system limits.</p> <p>Corrective measures:</p> <ul style="list-style-type: none"> • Check whether the grid parameters is still within the set system limits. • Contact the grid operator if necessary. |
| 9401 | <p>Energy saving mode of slaves in 1-phase parallel op</p> |
| 9402 | <p>Energy saving in the network</p> |
| 9403 | <p>Energy saving mode start</p> |
| 9404 | <p>Energy saving mode stop</p> |
| 9601 | <p>Digital input at [xx] has changed its status to [xx]</p> |
| 10001 | <p>Parallel grid operation</p> |
| 10003 | <p>Operation status</p> |
| 10004 | <p>Cold start status</p> |
| 10006 | <p>Startup status</p> |
| 10007 | <p>Stop status</p> |
| 10010 | <p>Restart diagnosis system in device</p> |

| Event number | Message, cause and corrective measures |
|--------------|--|
| 10060 | Operation at generator (at external input) |
| 10061 | Feeding network op (at external input) |
| 10100 | Parameter [xx] set successfully. [xx] to [xx] The displayed parameter was successfully changed. |
| 10101 | Setting of parameter [xx] failed. [xx] to [xx] The displayed parameter was not changed. Corrective action: <ul style="list-style-type: none"> • Make sure thresholds of the parameters are complied with. • Change the parameter again. |
| 10102 | Parameter [xx] set successfully. [xx] to [xx] The displayed parameter was successfully changed. |
| 10103 | Setting of parameter [xx] failed. [xx] to [xx] The displayed parameter was not changed. Corrective measures: <ul style="list-style-type: none"> • Make sure thresholds of the parameters are complied with. • Change the parameter again. |
| 10104 | String parameter set successfully |
| 10105 | String parameter setting failed |
| 10108 | Time adjusted / old time |
| 10109 | Time adjusted / new time |
| 10110 | Time synchronization failed: [xx] |
| 10114 | No time information could be called up from the set NTP server. Corrective measures: <ul style="list-style-type: none"> • Ensure that the NTP server was configured correctly. • Ensure that the inverter is integrated into a local network with Internet connection. |
| 10117 | Invalid date > Set time and date System time is invalid. Corrective measures: <ul style="list-style-type: none"> • Set the Date and Device Time via the installation assistant. |
| 10118 | Parameter upload successfully performed The configuration file was loaded successfully. |
| 10121 | Setting of parameter [xx] failed. Device must be stopped first |
| 10122 | Setting of parameter Lxx failed. Installation assistant must be started |

| Event number | Message, cause and corrective measures |
|----------------|--|
| 10248 to 10249 | <p data-bbox="389 241 863 275">Network busy > Network overloaded</p> <p data-bbox="389 286 1428 353">The network is busy. Data exchange between the devices is not at an optimum and is greatly delayed.</p> <p data-bbox="389 365 655 398">Corrective measures:</p> <ul data-bbox="411 409 1090 544" style="list-style-type: none"> <li data-bbox="411 409 951 443">• Reduce the number of devices in the network. <li data-bbox="411 454 959 488">• If necessary, increase the data query intervals. <li data-bbox="411 499 1090 544">• If necessary, reduce the number of devices in the network. |
| 10250 | <p data-bbox="411 566 695 600">⚠ QUALIFIED PERSON</p> <p data-bbox="389 622 770 656">Package error rate [ok / high]</p> <p data-bbox="389 667 1401 734">The package error rate has changed. If the package error rate is high, the network is overloaded or the connection to the network switch or DHCP server (router) is disrupted.</p> <p data-bbox="389 745 655 779">Corrective measures:</p> <ul data-bbox="411 790 1401 992" style="list-style-type: none"> <li data-bbox="411 790 1401 857">• Ensure that with an Ethernet connection, the network cable and the network connector are not damaged and that the network connectors are correctly plugged. <li data-bbox="411 869 959 902">• If necessary, increase the data query intervals. <li data-bbox="411 913 1401 992">• If necessary, reduce the number of devices in the network. 12 Troubleshooting SMA Solar Technology AG 78 |
| 10251 | <p data-bbox="389 1014 1278 1048">Communication status goes to [OK / Warning / Error / Not connected]</p> <p data-bbox="389 1059 1428 1126">The communication status to the network switch or DHCP server (router) has changed. An additional error message may be displayed.</p> |
| 10252 | <p data-bbox="411 1149 695 1182">⚠ QUALIFIED PERSON</p> <p data-bbox="389 1205 711 1238">Communication disrupted</p> <p data-bbox="389 1249 871 1283">There is no valid signal on the network line.</p> <p data-bbox="389 1294 655 1328">Corrective measures:</p> <ul data-bbox="411 1339 1401 1496" style="list-style-type: none"> <li data-bbox="411 1339 1401 1406">• Ensure that with an Ethernet connection, the network cable and the network connector are not damaged and that the network connectors are correctly plugged. <li data-bbox="411 1417 1401 1496">• Ensure that the DHCP server (router) and any network switches are signaling correct operation. |
| 10253 | <p data-bbox="411 1518 695 1552">⚠ QUALIFIED PERSON</p> <p data-bbox="389 1574 983 1608">Connection speed goes to [100 Mbit / 10 Mbit]</p> <p data-bbox="389 1619 1401 1686">The data transfer rate has changed. The cause for the status [10 Mbit] can be a defective plug, a defective cable or the pulling or plugging of the network connector.</p> <p data-bbox="389 1697 954 1731">Corrective measures if the status is [10 Mbit]:</p> <ul data-bbox="411 1742 1401 1910" style="list-style-type: none"> <li data-bbox="411 1742 1401 1809">• Ensure that with an Ethernet connection, the network cable and the network connector are not damaged and that the network connectors are correctly plugged. <li data-bbox="411 1821 1401 1910">• Ensure that the DHCP server (router) and any network switches are signaling correct operation. |

| Event number | Message, cause and corrective measures |
|--------------|---|
| 10254 | <p data-bbox="432 241 732 280">⚠ QUALIFIED PERSON</p> <p data-bbox="427 302 850 336">Duplex mode goes to [Full / Half]</p> <p data-bbox="427 347 1477 416">The duplex mode (data transfer mode) has changed. The cause for the status [Half] can be a defective plug, a defective cable or the pulling or plugging of the network connector.</p> <p data-bbox="427 427 948 461">Corrective measures if the status is [Half]:</p> <ul data-bbox="448 472 1442 622" style="list-style-type: none"> <li data-bbox="448 472 1442 542">• Ensure that with an Ethernet connection, the network cable and the network connector are not damaged and that the network connectors are correctly plugged. <li data-bbox="448 553 1442 622">• Ensure that the DHCP server (router) and any network switches are signaling correct operation. |
| 10255 | <p data-bbox="427 645 655 678">Network load OK</p> <p data-bbox="427 689 1174 725">The network load has returned to a normal range after being busy.</p> |
| 10282 | <p data-bbox="427 748 935 781">[User group]-Login via [protocol] locked</p> <p data-bbox="427 792 1453 862">After several incorrect login attempts, login has been blocked for a limited time. In this case, the User login will be blocked for 15 minutes, the Grid Guard login for 12 hours.</p> <p data-bbox="427 873 692 907">Corrective measures:</p> <ul data-bbox="448 918 1123 958" style="list-style-type: none"> <li data-bbox="448 918 1123 958">• Wait until the given time has expired and then retry login. |
| 10283 | <p data-bbox="427 981 695 1014">WLAN module faulty</p> <p data-bbox="427 1025 1059 1059">The WLAN module integrated in the inverter is defective.</p> <p data-bbox="427 1070 692 1104">Corrective measures:</p> <ul data-bbox="448 1115 1139 1155" style="list-style-type: none"> <li data-bbox="448 1115 1139 1155">• Contact the Service (see Section 19 "Contact", page 189). |
| 10284 | <p data-bbox="432 1178 732 1216">⚠ QUALIFIED PERSON</p> <p data-bbox="427 1238 812 1272">No WLAN connection possible</p> <p data-bbox="427 1283 1337 1317">The inverter does not currently have a WLAN connection to the selected network.</p> <p data-bbox="427 1328 692 1361">Corrective measures:</p> <ul data-bbox="448 1373 1442 1637" style="list-style-type: none"> <li data-bbox="448 1373 1442 1480">• Ensure that the SSID, the WLAN password and the encryption method have been entered correctly. The encryption method is specified by your WLAN router or WLAN Access Point and can be changed there. <li data-bbox="448 1491 1393 1561">• Ensure that the WLAN router or WLAN Access Point is in range and is signaling correct operation. <li data-bbox="448 1572 1422 1637">• If this message is displayed often, improve the WLAN connection by using a WLAN repeater. |
| 10285 | <p data-bbox="427 1659 804 1693">WLAN connection established</p> <p data-bbox="427 1704 1155 1740">Connection to the selected WLAN network has been established.</p> |

| Event number | Message, cause and corrective measures |
|--------------|--|
| 10286 | <p>⚠ QUALIFIED PERSON</p> <p>WLAN connection lost</p> <p>The inverter has lost WLAN connection to the selected network.</p> <p>Corrective measures:</p> <ul style="list-style-type: none"> • Ensure that the WLAN router or WLAN Access Point is still active. • Ensure that the WLAN router or WLAN Access Point is in range and is signaling correct operation. • If this message is displayed often, improve the WLAN connection by using a WLAN repeater. |
| 10287 | <p>WLAN module detected</p> |
| 10339 | <p>Webconnect enabled</p> <p>The inverter can communicate with Sunny Portal without an additional SMA communications product (e.g. Sunny Home Manager).</p> |
| 10340 | <p>Webconnect disabled</p> <p>The Webconnect function has been switched off. This means that the inverter can not communicate with Sunny Portal without an additional SMA communications product (e.g. Sunny Home Manager).</p> <ul style="list-style-type: none"> • If the inverter is to communicate with Sunny Portal without an additional SMA communication product, switch the Webconnect function on. |
| 10341 | <p>Webconnect error: no connection</p> <p>It is likely that there is an error in the network settings.</p> <p>Corrective measures:</p> <ul style="list-style-type: none"> • Check the network components (DLAN, WLAN Access Point etc.). • Ensure that the following ports are not blocked: <ul style="list-style-type: none"> - Registrar: ied.sma.de:9523 - Proxy: ied.sma.de:9523 - Stun: stun.sma.de:3478 - Domain: ied.sma.de (for SIP URI) |
| 10343 | <p>Webconnect error: Default gateway not configured</p> <p>It is likely that there is an error in the network settings.</p> <p>Corrective measures:</p> <ul style="list-style-type: none"> • Check the network components (DLAN, WLAN Access Point etc.). • Ensure that the following ports are not blocked: <ul style="list-style-type: none"> - Registrar: ied.sma.de:9523 - Proxy: ied.sma.de:9523 - Stun: stun.sma.de:3478 - Domain: ied.sma.de (for SIP URI) |

| Event number | Message, cause and corrective measures |
|--------------|--|
| 10344 | <p data-bbox="427 241 1007 271">Webconnect error: DNS server not configured</p> <p data-bbox="427 286 1007 315">It is likely that there is an error in the network settings.</p> <p data-bbox="427 331 691 360">Corrective measures:</p> <ul data-bbox="448 376 1214 640" style="list-style-type: none"><li data-bbox="448 376 1214 405">• Check the network components (DLAN, WLAN Access Point etc.).<li data-bbox="448 421 1007 640">• Ensure that the following ports are not blocked:<ul data-bbox="501 472 839 640" style="list-style-type: none"><li data-bbox="501 472 839 501">– Registrar: ied.sma.de:9523<li data-bbox="501 517 804 546">– Proxy: ied.sma.de:9523<li data-bbox="501 562 799 591">– Stun: stun.sma.de:3478<li data-bbox="501 607 903 636">– Domain: ied.sma.de (for SIP URI) |
| 10345 | <p data-bbox="427 667 1007 696">No reply to DNS request</p> <p data-bbox="427 712 1007 741">It is likely that there is an error in the network settings.</p> <p data-bbox="427 757 691 786">Corrective measures:</p> <ul data-bbox="448 801 1214 1066" style="list-style-type: none"><li data-bbox="448 801 1214 831">• Check the network components (DLAN, WLAN Access Point etc.).<li data-bbox="448 846 1007 1066">• Ensure that the following ports are not blocked:<ul data-bbox="501 898 839 1066" style="list-style-type: none"><li data-bbox="501 898 839 927">– Registrar: ied.sma.de:9523<li data-bbox="501 943 804 972">– Proxy: ied.sma.de:9523<li data-bbox="501 987 799 1016">– Stun: stun.sma.de:3478<li data-bbox="501 1032 903 1061">– Domain: ied.sma.de (for SIP URI) |
| 10346 | <p data-bbox="427 1093 1007 1122">SIP proxy DNS resolution failed</p> <p data-bbox="427 1137 1007 1167">It is likely that there is an error in the network settings.</p> <p data-bbox="427 1182 691 1211">Corrective measures:</p> <ul data-bbox="448 1227 1214 1491" style="list-style-type: none"><li data-bbox="448 1227 1214 1256">• Check the network components (DLAN, WLAN Access Point etc.).<li data-bbox="448 1272 1007 1491">• Ensure that the following ports are not blocked:<ul data-bbox="501 1323 839 1491" style="list-style-type: none"><li data-bbox="501 1323 839 1352">– Registrar: ied.sma.de:9523<li data-bbox="501 1368 804 1397">– Proxy: ied.sma.de:9523<li data-bbox="501 1413 799 1442">– Stun: stun.sma.de:3478<li data-bbox="501 1458 903 1487">– Domain: ied.sma.de (for SIP URI) |
| 10347 | <p data-bbox="427 1518 1007 1547">Stun server DNS resolution failed</p> <p data-bbox="427 1563 1007 1592">It is likely that there is an error in the network settings.</p> <p data-bbox="427 1608 691 1637">Corrective measures:</p> <ul data-bbox="448 1653 1214 1917" style="list-style-type: none"><li data-bbox="448 1653 1214 1682">• Check the network components (DLAN, WLAN Access Point etc.).<li data-bbox="448 1697 1007 1917">• Ensure that the following ports are not blocked:<ul data-bbox="501 1749 839 1917" style="list-style-type: none"><li data-bbox="501 1749 839 1778">– Registrar: ied.sma.de:9523<li data-bbox="501 1794 804 1823">– Proxy: ied.sma.de:9523<li data-bbox="501 1839 799 1868">– Stun: stun.sma.de:3478<li data-bbox="501 1883 903 1912">– Domain: ied.sma.de (for SIP URI) |

| Event number | Message, cause and corrective measures |
|--------------|---|
| 10348 | <p>Webconnect error: No reply to request to STUN server</p> <p>It is likely that there is an error in the network settings.</p> <p>Corrective measures:</p> <ul style="list-style-type: none"> • Check the network components (DLAN, WLAN Access Point etc.). • Ensure that the following ports are not blocked: <ul style="list-style-type: none"> - Registrar: ied.sma.de:9523 - Proxy: ied.sma.de:9523 - Stun: stun.sma.de:3478 - Domain: ied.sma.de (for SIP URI) |
| 10349 | <p>Webconnect error: No reply to SIP option packs</p> <p>It is likely that there is an error in the network settings or a Sunny Portal maintenance message is present.</p> <p>Corrective measures:</p> <ul style="list-style-type: none"> • If a Sunny Portal maintenance message is present, wait until the maintenance has been completed. • Check the network components (DLAN, WLAN Access Point etc.). • Ensure that the following ports are not blocked: <ul style="list-style-type: none"> - Registrar: ied.sma.de:9523 - Proxy: ied.sma.de:9523 - Stun: stun.sma.de:3478 - Domain: ied.sma.de (for SIP URI) |
| 10350 | <p>Webconnect error: Registration rejected by SIP registrar</p> <p>It is likely that there is an error in the network settings.</p> <p>Corrective measures:</p> <ul style="list-style-type: none"> • Check the network components (DLAN, WLAN Access Point etc.). • Ensure that the following ports are not blocked: <ul style="list-style-type: none"> - Registrar: ied.sma.de:9523 - Proxy: ied.sma.de:9523 - Stun: stun.sma.de:3478 - Domain: ied.sma.de (for SIP URI) |
| 10351 | <p>Unknown SIP registry</p> <p>It is likely that there is an error in the network settings.</p> <p>Corrective measures:</p> <ul style="list-style-type: none"> • Check the network components (DLAN, WLAN Access Point etc.). • Ensure that the following ports are not blocked: <ul style="list-style-type: none"> - Registrar: ied.sma.de:9523 - Proxy: ied.sma.de:9523 - Stun: stun.sma.de:3478 - Domain: ied.sma.de (for SIP URI) |

| Event number | Message, cause and corrective measures |
|--------------|---|
| 10352 | <p>Webconnect error: Faulty communication</p> <p>It is likely that there is an error in the network settings or a Sunny Portal maintenance message is present.</p> <p>Corrective measures:</p> <ul style="list-style-type: none"> • If a Sunny Portal maintenance message is present, wait until the maintenance has been completed. • Check the network components (DLAN, WLAN Access Point etc.). • Ensure that the following ports are not blocked: <ul style="list-style-type: none"> - Registrar: ied.sma.de:9523 - Proxy: ied.sma.de:9523 - Stun: stun.sma.de:3478 - Domain: ied.sma.de (for SIP URI) |
| 10353 | <p>Webconnect error: registration of the SIP registry has not responded</p> <p>It is likely that there is an error in the network settings or a Sunny Portal maintenance message is present.</p> <p>Corrective measures:</p> <ul style="list-style-type: none"> • If a Sunny Portal maintenance message is present, wait until the maintenance has been completed. • Check the network components (DLAN, WLAN Access Point etc.). • Ensure that the following ports are not blocked: <ul style="list-style-type: none"> - Registrar: ied.sma.de:9523 - Proxy: ied.sma.de:9523 - Stun: stun.sma.de:3478 - Domain: ied.sma.de (for SIP URI) |
| 10414 | Shutdown due to fault |
| 10415 | Automatic start |
| 10416 | Manual start (change-over from standby to op) |
| 10417 | Manual stop (change-over from op to standby) |
| 10418 | Ext. start via system control (chg-over from op to standby) |
| 10419 | Ext. stop via system control (chg-over from op to standby) |
| 10420 | <p>Internal consumption control was started</p> <p>The battery is automatically charged or discharged depending on the purchased electricity or the grid feed-in.</p> |
| 10421 | <p>Internal consumption control was stopped</p> <p>The automatic charging or discharging of the battery stopped due to an external control command.</p> |

| Event number | Message, cause and corrective measures |
|--------------|--|
| 10422 | <p>Only charging operation in internal consumption mode</p> <p>The battery is charged only when increased self-consumption is active. The battery is only charged again once there is sufficient PV power in the system.</p> |
| 10423 | <p>Full or equalization charge with active increased self-consumption</p> |
| 10424 | <p>Switch back to increased self-consumption after completion of full or equalization charge</p> |
| 10425 | <p>The device switches off</p> |
| 10426 | <p>Multifunction relay [xx] of device at Lxx is [xx]</p> |
| 10427 | <p>Transfer relay [xx] of device at Lxx is [xx]</p> |
| 10428 | <p>Event [xx] of process interface</p> |
| 10429 | <p>Message from process interface: [xx]</p> |
| 10517 | <p>Dynamic active power limitation started.</p> <p>The inverter limits the active power of the PV inverters to the set limit.</p> |
| 10518 | <p>Dynamic active power limitation terminated.</p> <p>The inverter terminated the active power limitation of the PV inverters.</p> |
| 10520 | <p>⚠ QUALIFIED PERSON</p> <p>Supplied power: [xx] W (permitted value: [xx] W)</p> <p>The set active power limitation cannot be met.</p> <p>Corrective measures:</p> <ul style="list-style-type: none"> • Ensure that the correct active power limitation has been configured. • Ensure that the PV inverters have been configured correctly. • Ensure that the communication between battery inverter and PV inverter functions perfectly. • Ensure that no external feeders are in the system. |
| 10521 | <p>Active power was limited today for [xx] minutes.</p> <p>The active power limitation of the PV inverters was limited for the specified time.</p> |
| 10528 | <p>Login for NSD function on device [xx] failed</p> |
| 10704 | <p>The current sensor is not connected, not available or defective</p> <p>Corrective measures:</p> <ul style="list-style-type: none"> • Contact the Service (see Section 19, page 189). |

15.3 Acknowledge Errors

If a disturbance (e.g. generator false starts are occurring too often) can lead to the system being permanently damaged, the inverter switches to the **Standby** operating state. To enable a restart of the system, you must eliminate the cause of the disturbance and acknowledge the error.

The basic procedure for changing operating parameters is explained in another section (see Section 9.2 "Changing Operating Parameters", page 119).

Requirement:

- The cause of the error must be eliminated.

Procedure:

1. Select **Device > Operation**.
2. Set **Reset operating data** to **Reset operation inhibition**.
3. Start the system (see Section 10.2, page 124).

15.4 Frequently Asked Questions (FAQs)

15.4.1 Questions Regarding the Sunny Island

Why is the Sunny Island not switching off even though I have opened the load-break switch of the battery fuse?

The Sunny Island may still be supplied from the AC side.

⚠ QUALIFIED PERSON

- Switch off all AC sources and disconnect them from the Sunny Island.

Why is the Sunny Island not switching to energy-saving mode?

Another function might have a higher priority than energy saving mode, e.g., equalization charge or full charge.

After automatic disconnection in battery protection mode, the Sunny Island can no longer be started?

⚠ QUALIFIED PERSON

- Charge the battery only when the Sunny Island cannot be switched on (see Section 14.7 "Charging the Battery After Automatic Shutdown in Off-Grid Systems (Emergency Charge Mode)", page 137).
 - Switch off all loads.
 - If there is a generator in the system, start the generator manually. When doing so, observe the warm-up time of the generator. Five minutes without charge current can result in disconnection of the Sunny Island inverter.
 - If sufficient power is available from the generator or the AC sources in the stand-alone grid, e.g., sufficient solar irradiation for PV inverters, switch the Sunny Island on. AC sources in the stand-alone grid can start feeding in electric current only once the Sunny Island has been started and is in operation.

15.4.2 Questions Regarding the Battery

What happens if a battery is defective?

⚠ QUALIFIED PERSON

- Remove the defective battery cell from the battery system. This reduces the rated voltage of the battery by the voltage of the battery cell.
- Start the installation assistant on the inverter user interface.
- Select [**Save and next**] up to the step **Battery configuration**.
- Select the button [**New battery configuration**].
- Set the parameter **Voltage** to the actual rated voltage of the battery (see Section 14.9 "Replacing the Battery", page 140).

Why is the SOC of the battery not 100% after completion of full charge?

The power requirements of the loads might have been so high before completion of the full charge that the battery could not be charged to 100 percent.

- Where necessary, select **Battery > Charge** and set the parameter **Battery full charge time** to a longer time period.

Why is the battery discharging even though the generator is running?

The Sunny Island may not have connected to the generator.

- Eliminate the cause (see Section 15.4.3 "Questions Regarding the Generator", page 176).

The power of the loads might exceed the power of the generator.

What do you need to do after replacing a battery current sensor?

⚠ QUALIFIED PERSON

- Calibrate the battery current sensor (see the Commissioning section in the Sunny Island inverter installation manual).

15.4.3 Questions Regarding the Generator

Why is the Sunny Island not connecting to the running generator?

A high output power of the Sunny Island inverter when the battery state of charge is low may lead to the Sunny Island not being able to raise the AC voltage in the stand-alone grid to the AC voltage of the generator. The Sunny Island cancels the synchronization.

- To charge the battery, reduce the power of the loads.

The generator voltage might not be within the thresholds for voltage and frequency.

- Check whether the voltage and frequency of the generator are within the thresholds set (see technical information "Parameters and Measured Values" at <http://www.SMA-Solar.com>).
 - If the voltage and frequency of the generator are not within the thresholds set, ensure that the fuse is not defective or that the circuit breaker is switched on.
 - If the voltage and frequency of the generator are only sometimes within the thresholds set, set the thresholds for the voltage and frequency of the generator voltage (see Sunny Island inverter installation manual).
 - If the voltage and frequency of the generator are within the thresholds set, the Sunny Island is in the warm-up period or is blocked for connection.

Why does the Sunny Island connect to the generator for only a short time?

The generator may be overloaded.

- Select **Generator > Generator** and set the parameter **Rated generator current** to 75% of the rated current of the generator.
- If possible, reduce the power of the loads.

The maximum permissible generator voltage may be set too low.

⚠ QUALIFIED PERSON

- Select **Generator > Generator** and set the parameter **Voltage monit. gener. upper maximum threshold** to the maximum generator voltage.

The minimum frequency for the generator voltage may be set too high.

⚠ QUALIFIED PERSON

- Select **Generator > Generator** and set the parameter **Frequency monit. generator lower minimum threshold** to the minimum frequency of the generator voltage.

It may be that the permissible time for reverse power was exceeded (see **Generator > Generator > Power monitoring > Volt. monit. gener. max. reverse power trip. time**).

- Check whether the warning **Reverse power prot. (generator)** has been entered in the menu **Events**.
- Select **Generator > Generator > Operation** and set the parameter **Acknowledge generator errors** to **Execute**. This acknowledges the generator error.

The Sunny Island does not reconnect to the generator after disconnection from the generator due to non-compliance with the thresholds for voltage and frequency – why?

The Sunny Island is switched with a hysteresis, i.e., the thresholds for connection do not correspond to the thresholds for disconnection.

- To unload the generator, disconnect unnecessary loads.
- Wait until the voltage and frequency have reached the nominal values.

15.4.4 Questions Regarding Multicluster Systems

Extension clusters remain in standby mode even though the main cluster is in inverter mode?

The data cable between the masters of the individual clusters might not be connected. The master of the main cluster cannot forward the "Start" command to the masters of the extension clusters.

Why is the multicluster system not supplying full power?

An extension cluster or individual Sunny Island inverters of an extension cluster might have failed.

Why are high levels of energy being transferred between the clusters in the multicluster system?

The state of charge of the batteries might differ temporarily. The off-grid system equalizes different states of charge automatically.

The nominal frequencies and nominal voltages may be defined differently.

- Select **Device > Inverter** and set the parameters **Inverter nominal voltage** and **Inverter nominal frequency** to the same value for all masters.

The battery capacities might differ significantly.

⚠ QUALIFIED PERSON

- Distribute the battery capacities to the clusters as evenly as possible.

Individual battery cells of a battery might have failed.

⚠ QUALIFIED PERSON

- Disconnect defective battery cells and set the new rated voltage and capacity (see Section 14.9 "Replacing the Battery", page 140).

16 Decommissioning the Sunny Island

⚠ QUALIFIED PERSON

⚠ DANGER

Danger to life from electric shock due to high voltages

High voltages are present inside the inverter. When the enclosure lid is removed, live components can be touched that can result in death or serious injury due to electric shock.

- Disconnect the inverter from all voltage sources (see Section 13, page 132).
- After switching off the inverter, wait at least 15 minutes before opening the inverter to allow the capacitors to discharge completely.

1. Ensure that the Sunny Island is disconnected from all voltage sources (see Section 13, page 132).
2. Remove all cables from the Sunny Island.
3. Close the Sunny Island.
4. Remove the ventilation grids laterally.

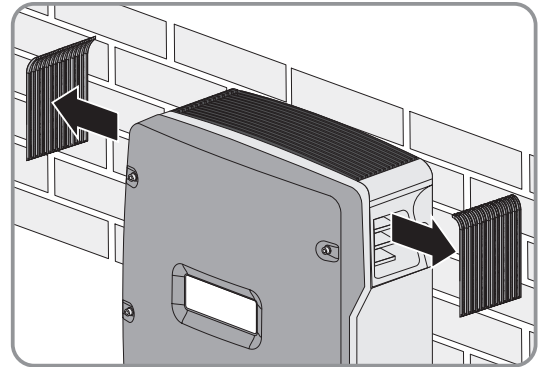

5. If the Sunny Island is protected against theft, loosen the security screws.

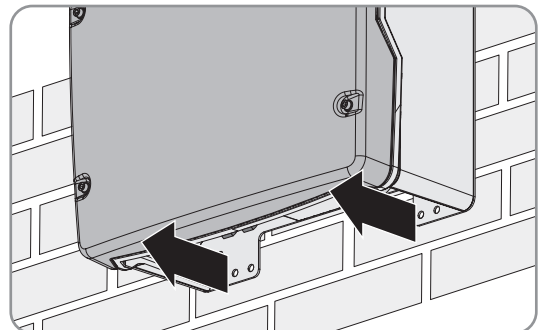

6. Loosen the screws on both sides between the Sunny Island and the wall mounting bracket using a hex key (AF 5).

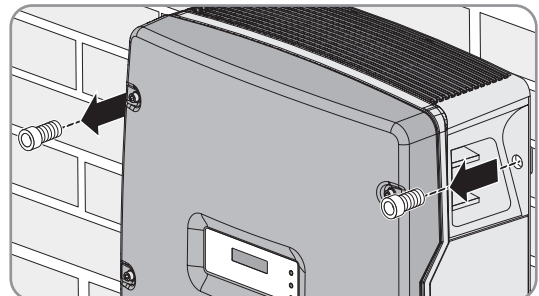

7. **CAUTION****Risk of injury due to the heavy weight of the Sunny Island inverter**

The Sunny Island inverter 4.4M weighs 44 kg, the Sunny Island inverter 6.0H / 8.0H weighs 63 kg. There is risk of injury if the inverter is lifted incorrectly or dropped while being transported or when attaching it to or removing it from the wall mounting bracket.

- Keep in mind the weight of the Sunny Island inverter.
- With the SI4.4M-12, remove the Sunny Island vertically upwards from the wall mounting bracket. For this, use the side recess grips. Keep the Sunny Island in a horizontal position when moving it.

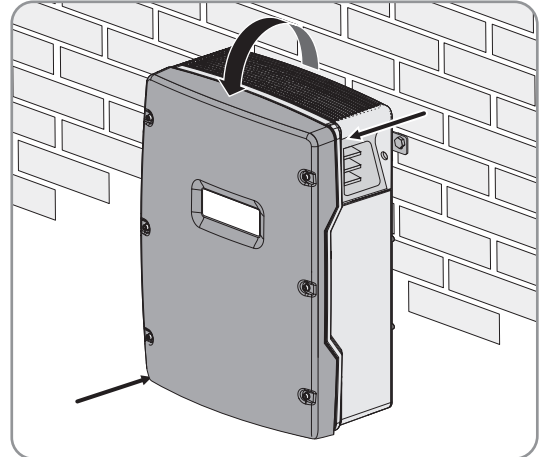

- With the SI6.0H-12 and SI8.0H-12, remove the Sunny Island vertically upwards from the wall mounting bracket. For this, use the side recess grips or a steel rod (diameter: maximum 30 mm). Keep the Sunny Island in a horizontal position when moving it.

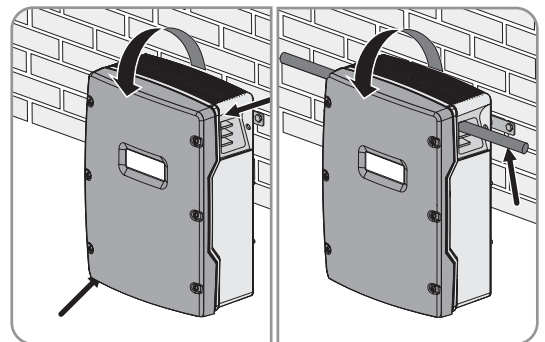

8. Remove the cable glands from the inverter.
9. If the inverter is to be stored or shipped, pack the inverter. Use the original packaging or packaging that is suitable for the weight and dimensions of the inverter.
10. Dispose of the inverter in accordance with the locally applicable disposal regulations for electronic waste.

17 Technical Data

17.1 AC1 Connection for Stand-Alone Grid

| | Sunny Island 4.4M | Sunny Island 6.0H | Sunny Island 8.0H |
|--|-----------------------------|------------------------------------|------------------------------------|
| Rated power | 3300 W | 4600 W | 6000 W |
| Power for 30 minutes at 25°C | 4400 W | 6000 W | 8000 W |
| Power for 5 minutes at 25°C | 4600 W | 6800 W | 9100 W |
| Power for 1 minutes at 25°C | 4800 W | 7500 W | 9600 W |
| Maximum AC power for 3 s at 25°C | 5500 W | 11000 W | 11000 W |
| Maximum connectable power of the PV inverters in off-grid systems and battery-backup systems | 4600 W | 9200 W | 12000 W |
| Maximum connectable AC power in the stand-alone grid with the use of AC sources* | 3300 W | 4600 W | 6000 W |
| Rated grid voltage | 230 V | 230 V | 230 V |
| Voltage range | 202 V to 253 V | 202 V to 253 V | 202 V to 253 V |
| Rated frequency | 50 Hz | 50 Hz | 50 Hz |
| Frequency range | 45 Hz to 65 Hz | 45 Hz to 65 Hz | 45 Hz to 65 Hz |
| Frequency range of the set range | ±10 Hz | ±10 Hz | ±10 Hz |
| Rated Current | 14.5 A | 20.0 A | 26.1 A |
| Maximum output current as a peak value for 60 milliseconds | 60 A | 120 A | 120 A |
| Total harmonic distortion of the output voltage (THD) | <5 % | <1.5 % | <1.5 % |
| Displacement power factor $\cos \varphi$ | -1 to +1 | -1 to +1 | -1 to +1 |
| Recommended conductor cross-section | 10 mm ² | 10 mm ² | 10 mm ² |
| Maximum connectable conductor cross-section | 16 mm ² | 16 mm ² | 16 mm ² |
| Cable diameter | 9 mm to 18 mm | 9 mm to 18 mm | 9 mm to 18 mm |
| Connection | Lever terminal | Lever terminal | Lever terminal |
| Circuit breakers than can be tripped | Tripping characteristics B6 | Tripping characteristics B16 or C6 | Tripping characteristics B16 or C6 |
| Short circuit power of the device | 13.8 kW | 27.6 kW | 27.6 kW |

* AC sources that can not be regulated by the Sunny Island (e.g. CHP plant)

17.2 AC2 Connection for Utility Grid and Generator (External Energy Source)

| | Sunny Island 4.4M | Sunny Island 6.0H | Sunny Island 8.0H |
|---|-----------------------|-----------------------|-----------------------|
| Maximum power in an off-grid system | 11 500 W | 11 500 W | 11 500 W |
| Rated voltage | 230 V | 230 V | 230 V |
| Voltage range | 172.5 V to 264.5 V | 172.5 V to 264.5 V | 172.5 V to 264.5 V |
| Rated frequency | 50 Hz | 50 Hz | 50 Hz |
| Permitted frequency range | 40 Hz to 70 Hz | 40 Hz to 70 Hz | 40 Hz to 70 Hz |
| Maximum current in off-grid systems | 50 A | 50 A | 50 A |
| Maximum current in SMA Flexible Storage System without battery backup function with one Sunny Island in Germany | 13.3 A | 20.0 A | 20.0 A |
| Maximum power in systems for increased self-consumption with one Sunny Island in Germany | 3300 W | 4600 W | 4600 W |
| Maximum inrush current for 4 ms | ±3.6 A | ±1 A | ±1 A |
| Maximum connectable power of the PV inverters in battery-backup systems | 5000 W | 9200 W | 12000 W |
| Recommended conductor cross-section | 10 mm ² | 10 mm ² | 10 mm ² |
| Maximum connectable conductor cross-section | 16 mm ² | 16 mm ² | 16 mm ² |
| Cable diameter | 9 mm to 18 mm | 9 mm to 18 mm | 9 mm to 18 mm |
| Connection | Lever terminal | Lever terminal | Lever terminal |
| Maximum back-up fuse | 50 A | 50 A | 50 A |

17.3 DC Connection for Battery

| | Sunny Island 4.4M | Sunny Island 6.0H | Sunny Island 8.0H |
|----------------------------------|---|---|---|
| Rated input voltage | 48 V | 48 V | 48 V |
| Voltage range | 41 V to 63 V | 41 V to 63 V | 41 V to 63 V |
| Rated charging current | 63 A | 90 A | 115 A |
| Rated discharging current | 75 A | 103 A | 136 A |
| Maximum battery charging current | 75 A | 110 A | 140 A |
| Battery type | Lead-acid battery: FLA, VRLA lithium- ion battery * | Lead-acid battery: FLA, VRLA lithium- ion battery * | Lead-acid battery: FLA, VRLA lithium- ion battery * |

| | Sunny Island 4.4M | Sunny Island 6.0H | Sunny Island 8.0H |
|---|---|---|---|
| Battery capacity range of lead-acid batteries | 100 Ah to 10000 Ah | 100 Ah to 10000 Ah | 100 Ah to 10000 Ah |
| Battery capacity range of lithium-ion batteries | 50 Ah to 10000 Ah | 50 Ah to 10000 Ah | 50 Ah to 10000 Ah |
| Recommended minimum battery capacity C10 in systems for increased self-consumption | 100 Ah | 100 Ah | 100 Ah |
| Recommended minimum battery capacity C10 in battery-backup systems | 100 Ah | 120 Ah | 160 Ah |
| Recommended minimum battery capacity C10 in off-grid systems | 150 Ah | 190 Ah | 250 Ah |
| Recommended minimum battery capacity C10 per 1,000 Wp power of PV systems in off-grid systems | 100 Ah | 100 Ah | 100 Ah |
| Charge control for lead-acid batteries | IUoU charging behavior with automatic full charge and equalization charge | IUoU charging behavior with automatic full charge and equalization charge | IUoU charging behavior with automatic full charge and equalization charge |
| DC connection | Terminal lug M8, 20 mm to 25 mm wide | Terminal lug M8, 20 mm to 25 mm wide | Terminal lug M8, 20 mm to 25 mm wide |
| Permitted conductor cross-section: | 50 mm ² to 95 mm ² ** | 50 mm ² to 95 mm ² ** | 50 mm ² to 95 mm ² ** |
| Maximum connectable conductor cross-section | 95 mm ² ** | 95 mm ² ** | 95 mm ² ** |
| Cable diameter | 14 mm to 25 mm | 14 mm to 25 mm | 14 mm to 25 mm |
| Torque | 12 Nm | 12 Nm | 12 Nm |

* The lithium-ion battery must be approved for use with the Sunny Island (see technical information at "List of Approved Batteries").

** In the event of a cross-section of 95 mm², observe the maximum cable diameter.

17.4 Efficiency

| | Sunny Island 4.4M | Sunny Island 6.0H | Sunny Island 8.0H |
|------------------------------|----------------------|----------------------|----------------------|
| Maximum efficiency | 95.3 % | 95.8 % | 95.8 % |
| European weighted efficiency | 94.0 % | 94.3 % | 94.1 % |

17.5 Sunny Island 4.4M Efficiency Profile

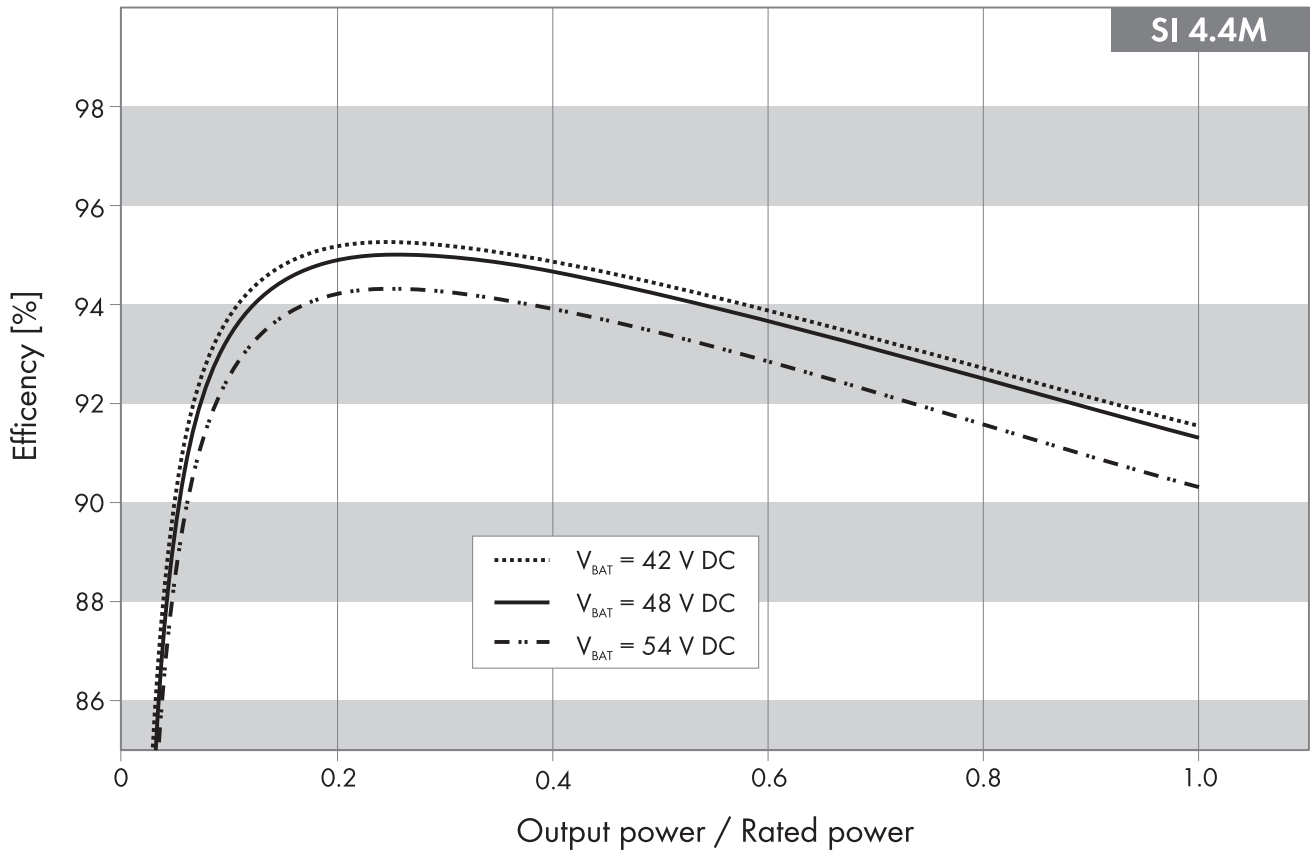

Figure 27: Characteristic efficiency curve

17.6 Sunny Island 6.0H Efficiency Profile

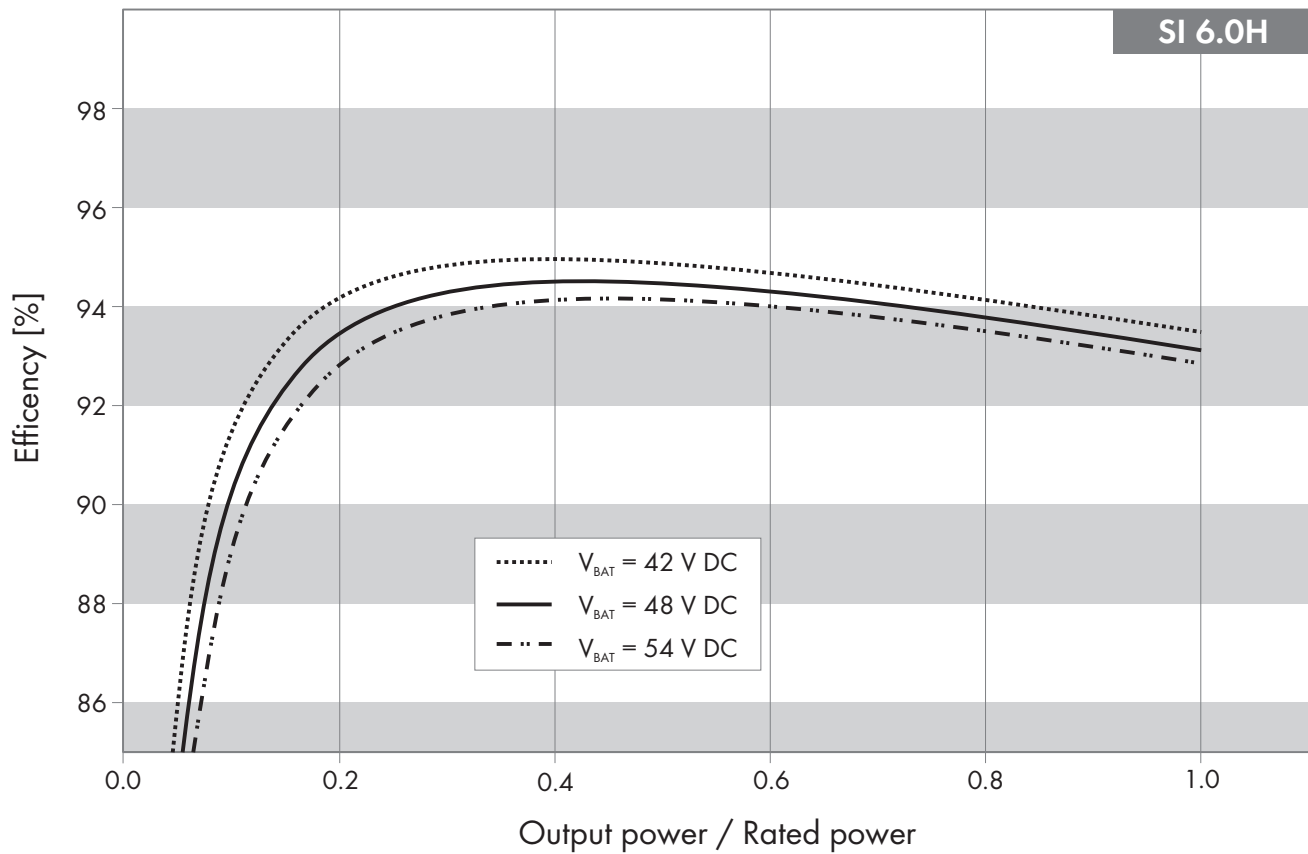

Figure 28: Characteristic efficiency curve

17.7 Sunny Island 8.0H Efficiency Profile

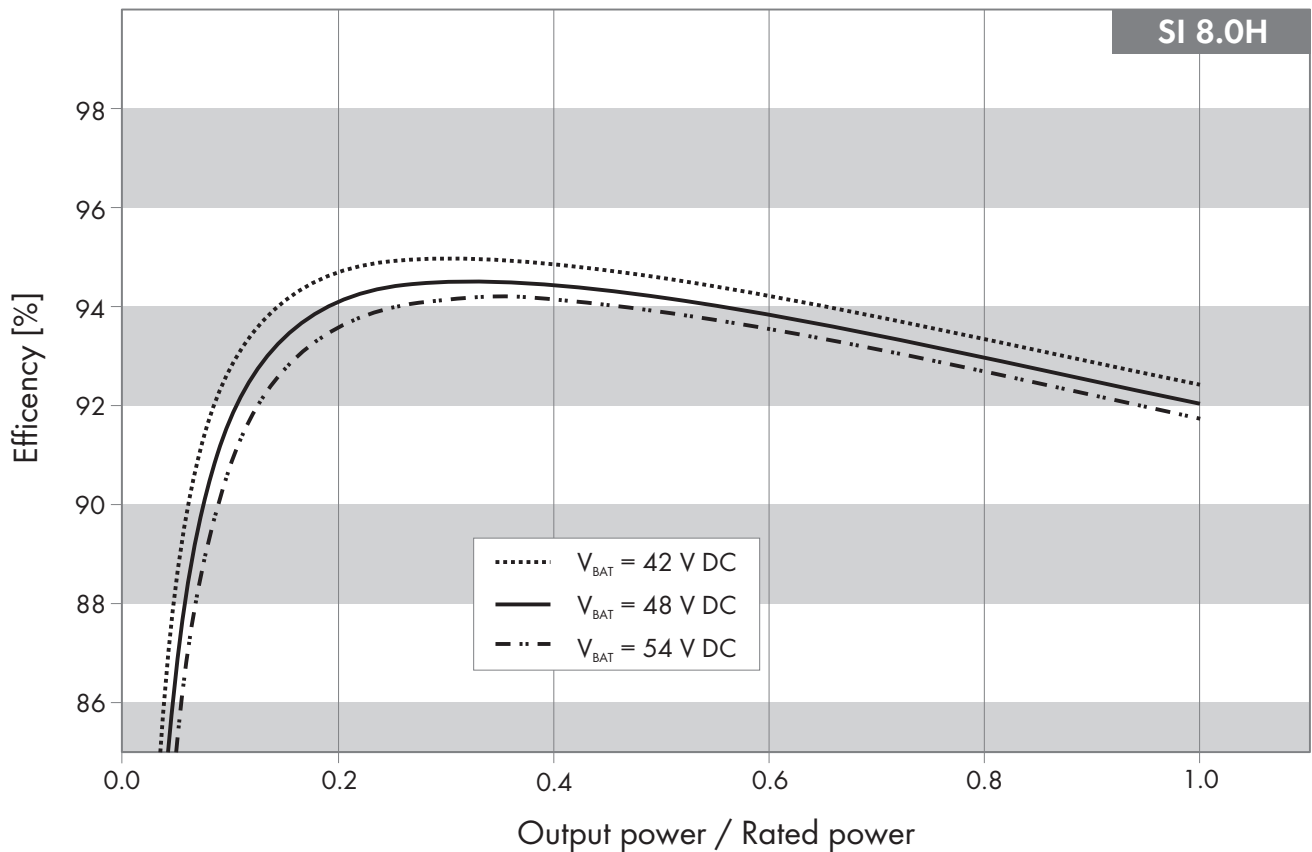

Figure 29: Characteristic efficiency curve

17.8 Energy Consumption in No-Load Operation and Standby

| | Sunny Island 4.4M | Sunny Island 6.0H | Sunny Island 8.0H |
|--|-------------------|-------------------|-------------------|
| Standby consumption | 6.8 W | 6.5 W | 6.5 W |
| Consumption in no-load operation and in discharge mode | 18.0 W | 25.8 W | 25.8 W |

17.9 Noise Emission

Noise emission, typical 49 dB(A)

17.10 Grid Configuration

TN-S grid configuration Suitable

TN-C-S grid configuration Suitable

TT grid configuration Suitable

17.11 Protective Devices

AC short-circuit yes

| | |
|---|---------------|
| AC overload | yes |
| DC reverse polarity protection | not available |
| Battery deep discharge | yes |
| Overtemperature | yes |
| Overvoltage category in accordance with IEC 60664-1 | III |

17.12 Equipment

| | |
|---|-------------------------------------|
| Number of buttons | 3 |
| Number of LEDs | 3 two-color LEDs |
| Number of interface slots | 1 |
| COM SYNC | for internal communication only |
| SI-SYSCAN.BGx | optional for Sunny Island 6.0H/8.0H |
| Number of digital control inputs | 1 |
| High level digital input | 9 V to 63 V |
| Low level digital input | 0 V to 3 V |
| Potential-free control contacts | Two multifunction relays |
| Number of connections for battery current sensors | 1 |
| Measuring accuracy with connected battery current sensor | ± 10 % |
| Maximum length of measuring cable on battery current sensor | 3 m |
| AC load switching limit for multifunction relays 1 and 2 | 1 A at 250 V |
| DC load switching limit for multifunction relays 1 and 2 | (see Section 17.14, page 187) |

17.13 Data Storage Capacity

| | With internal inverter memory | With optional micro SD card |
|--|-------------------------------|-----------------------------|
| Instantaneous values recorded per second over one day (1 file for 1 day) | - | over two months |
| Instantaneous values recorded over the duration of five minutes over one day (1 file for 1 day) | 64 days | - |
| Event messages | 1024 | Inverter service life |
| Instantaneous values recorded per second over two minutes before and after each error (1 file per error) | For 50 errors | For 50 errors |

17.14 DC Load Limitation Curve of the Multifunction Relays

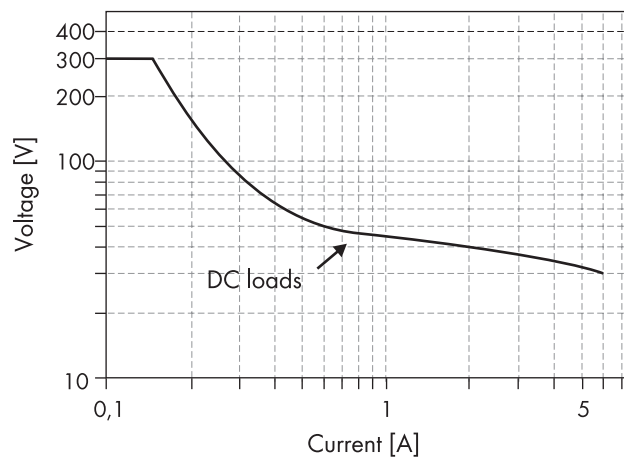

Figure 30: DC load limitation curve of multifunction relays 1 and 2

17.15 General Data

| | Sunny Island 4.4M | Sunny Island 6.0H / 8.0H |
|---|--------------------------|--------------------------|
| Width x height x depth | 467 mm x 612 mm x 242 mm | 467 mm x 612 mm x 242 mm |
| Weight | 44 kg | 63 kg |
| Operating temperature range | -25°C to +60°C | -25°C to +60°C |
| Storage temperature range | -25°C to +70°C | -25°C to +70°C |
| Humidity | 0% to 100% | 0% to 100% |
| Maximum installation height above MSL | 3000 m | 3000 m |
| Topology | LF transformer | LF transformer |
| Leakage current | 2.22 mA | 2.22 mA |
| Cooling method | SMA OptiCool | SMA OptiCool |
| Protection class in accordance with IEC 62103 | I | I |
| Climatic category in accordance with IEC 60721 | 3K6 | 3K6 |
| Degree of protection in accordance with IEC 60529 | IP54 | IP54 |
| Radio technology | WLAN 802.11 b/g/n | WLAN 802.11 b/g/n |
| Radio spectrum | 2.4 GHz | 2.4 GHz |
| Maximum transmission power | 100 mW | 100 mW |

18 Spare Parts and Accessories

You will find the corresponding accessories and spare parts for your product in the following overview. If required, these can be ordered from SMA Solar Technology AG or your distributor.

| Designation | Brief description | SMA order number |
|-----------------|---|------------------|
| SI-SYSCAN.BGx | Communication interface for communication between clusters in a multicluster system | SI-SYSCAN-NR |
| BAT-TEMP-SENSOR | Battery temperature sensor of the type KTY with connection line (length: 10 m) | BAT-TEMP-SENSOR |

19 Contact

If you have technical problems with our products, please contact the SMA Service Line. We require the following information in order to provide you with the necessary assistance:

- Sunny Island inverter type
- Sunny Island inverter serial number
- Sunny Island inverter firmware version
- Error message displayed
- Type of battery connected
- Nominal battery capacity
- Nominal battery voltage
- Type of the communication products connected
- Type and size of additional energy sources

In order to receive service assignments for the Sunny Island system, all system data must be recorded in the information sheet for Sunny Island systems during commissioning and made available to Service (for information sheet see www.SMA-Solar.com).

| | | | |
|-------------|--|----------------|--|
| Deutschland | SMA Solar Technology AG | Belgien | SMA Benelux BVBA/SPRL |
| Österreich | Niestetal | Belgique | Mechelen |
| Schweiz | Sunny Boy, Sunny Mini Central, Sunny Tripower: +49 561 9522-1499 | België | +32 15 286 730 |
| | Monitoring Systems (Kommunikationsprodukte): +49 561 9522-2499 | Luxemburg | SMA Online Service Center: www.SMA-Service.com |
| | Fuel Save Controller (PV-Diesel-Hybridsysteme): +49 561 9522-3199 | Luxembourg | |
| | Sunny Island, Sunny Boy Storage, Sunny Backup: +49 561 9522-399 | Nederland | |
| | Sunny Central, Sunny Central Storage: +49 561 9522-299 | Česko | SMA Service Partner TERMS a.s. |
| | SMA Online Service Center: www.SMA-Service.com | Magyarország | +420 387 6 85 111 |
| | | Slovensko | SMA Online Service Center: www.SMA-Service.com |
| | | Türkiye | SMA Service Partner DEKOM Ltd. Şti. +90 24 22430605 SMA Online Service Center: www.SMA-Service.com |
| France | SMA France S.A.S. Lyon +33 472 22 97 00 SMA Online Service Center : www.SMA-Service.com | Ελλάδα | SMA Service Partner AKTOR FM. |
| | | Κύπρος | Αθήνα +30 210 8184550 SMA Online Service Center: www.SMA-Service.com |
| España | SMA Ibérica Tecnología Solar, S.L.U. | United Kingdom | SMA Solar UK Ltd. |
| Portugal | Barcelona +34 935 63 50 99 SMA Online Service Center: www.SMA-Service.com | | Milton Keynes +44 1908 304899 SMA Online Service Center: www.SMA-Service.com |

| | | | |
|----------------------|---|--------------------------------------|--|
| Italia | SMA Italia S.r.l. Milano +39 02 8934-7299 SMA Online Service Center: www.SMA-Service.com | Australia | SMA Australia Pty Ltd. Sydney Toll free for Australia: 1800 SMA AUS (1800 762 287) International: +61 2 9491 4200 |
| United Arab Emirates | SMA Middle East LLC Abu Dhabi +971 2234 6177 SMA Online Service Center: www.SMA-Service.com | India | SMA Solar India Pvt. Ltd. Mumbai +91 22 61713888 |
| ไทย | SMA Solar (Thailand) Co., Ltd. กรุงเทพฯ +66 2 670 6999 | 대한민국 | SMA Technology Korea Co., Ltd. 서울 +82-2-520-2666 |
| South Africa | SMA Solar Technology South Africa Pty Ltd. Cape Town 08600SUNNY (08600 78669) International: +27 (0)21 826 0600 SMA Online Service Center: www.SMA-Service.com | Argentina Brasil Chile Perú | SMA South America SPA Santiago de Chile +562 2820 2101 |
| Other countries | International SMA Service Line Niestetal 00800 SMA SERVICE (+800 762 7378423) SMA Online Service Center: www.SMA-Service.com | | |

20 EU Declaration of Conformity

within the scope of the EU directives

- Electromagnetic compatibility 2014/30/EU (29.3.2014 L 96/79-106) (EMC)
- Low Voltage Directive 2014/35/EU (29.3.2014 L 96/357-374) (LVD)
- Radio Equipment Directive 2014/53/EU (22.5.2014 L 153/62) (RED)



SMA Solar Technology AG confirms herewith that the products described in this document are in compliance with the fundamental requirements and other relevant provisions of the above-mentioned directives. The entire EU Declaration of Conformity can be found at www.SMA-Solar.com.

**ENERGY
THAT
CHANGES**

