

# AUTO START CONTROLLER INSTALLATION / OPERATION MANUAL

Model: 2WIRE-AS2 (PRAMAC)

## Overview

The model 2WIRE-AS2, 2 Wire Auto Start generator controller is ready to use with your P and S series PRAMAC Portable Generators that are fitted with the CONN remote control connector plug. This will enable you to use your Pramac Generator in various applications like Standalone Solar and Standby Emergency Power with an ATS (auto transfer switch).

## Product Features

The 2WIRE-AS-1 controller is a basic 2 wire auto start accessory that manages the start/stop of the generator from a closed circuit open/closed contact from a third party control system like a solar inverter or ATS transfer switch. It also manages the basic generator running & protection to ensure easy operation. The package is supplied with a basic 12V battery charger for trickle charging of the generator battery during standby mode waiting for a start signal. Customers can use their own battery charging system but care must be taken to not over charge the battery voiding warranty. The basic setup is for a simple system suited for the PRAMAC Portable S & P series models with the CONN connector remote plug. S5000, S8000, S12000 & P12000 Honda PETROL models automatically engage the CHOKE during the starting/cranking cycle for starting in all modes.

## Installation

**NOTE:** PRAMAC Generators supplied with the 2WIRE-AS2 can start automatically at anytime. For safe operation we advise the generator is clearly labelled advising that, **“Generator may start at anytime without warning”**. Turn the key off prior to refuelling, maintenance or storage. Also ensure that the generator is installed in a well-ventilated area, ensuring exhaust gases are not recycled back into the engine or where fumes could cause harm to people or animals.

The 2WIRE-AS-1 comes pre-wired, making it ready to plug into your PRAMAC Generator. The control plug will connect directly into the Pramac CONN Remote Control connector plug on the P & S series Portable Generators. It also comes standard with a 3 pin plug top that is plugged into your generator output socket or hardwired into the generator, giving the controller the required generator voltage feedback (NOTE; must be installed for controller to operate correctly). If the 230 volt feedback wire is required to be hard wired, just cut the plug off and hard wire it to a suitably protected generator output circuit. The 2WIRE-AS-1 can also start the generator off a 12 volt DC signal, you just have to move the flex into the Auto 12v terminals inside the controller enclosure. Due to there being a small load on the battery when the controller is in Auto mode, a battery charger is also provided to keep your battery in a fully charged state. Just plug your ‘plug pack’ style charger into the provided socket on the base of the controller. You can also use a suitable small solar panel regulated charger plugged into the same socket.

## Operation

To operate your 2WIRE-AS2 controller, simply connect as above and turn the generator key to the ‘ON’ position. The LCD screen on the controller will power up, allowing you to either manual start/stop the generator or activate AUTO mode. To manually start the generator you can either use the key on the set, or simply press the green start button. This will initiate the start sequence of the controller, with a small delay before the generator starts to turn over. If there are any problems, and the generator fails to start, an error code will appear on the LCD panel. Your generator has been factory checked & tested, but if you have any problems, it is recommended to do the initial start up using the key start. To stop the generator, press the red Stop button. This will initiate the stop sequence, but the generator will not shut down straight away due to 30 second cool down cycle.

**Choke:** The system automatically engages the choke during the starting/crank cycle which works for the PETROL models.

To set the controller to start from the 2 wire or 12 volt signal automatically, simply press the middle AUTO button. The LED indicator above the AUTO button will illuminate showing you that it is in AUTO mode. As noted above, please make sure that you have a 12 volt battery charger source plugged in to offset the small load on the battery while in Auto mode. Once the controller has received the start signal there is a short delay while the controller goes through its start sequence. Once the controller reads a voltage from the alternator/generator, it will complete the start cycle and keep the generator running until the stop signal is received. Once the 2 wire or 12 volt run signal is removed the generator will go into the stop mode, with a 30 second cool down delay meaning the generator will not stop straight away.

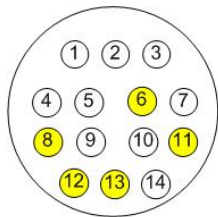
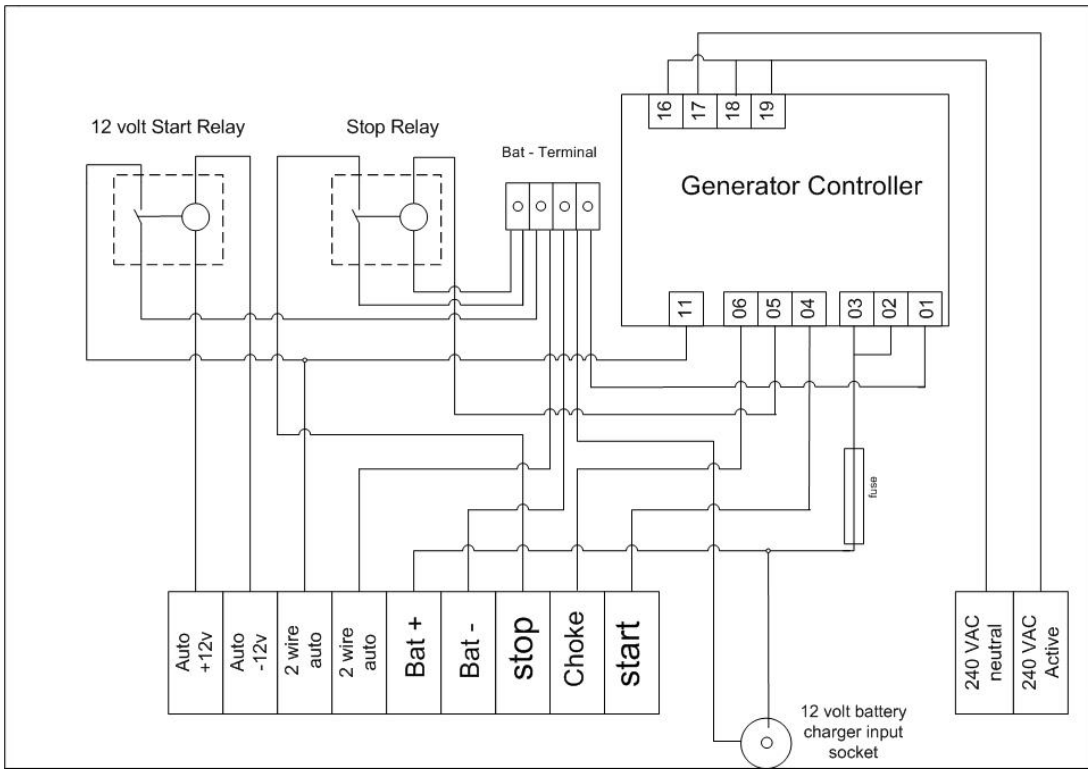

6	BATTERY +	RED
8	BATTERY -	BLACK
11	CHOKE	
12	START	
13	STOP	

